



MODEL EC4000

TELESCOPIC CRANE OWNERS' MANUAL

Installation • Assembly Drawings • Parts

20 Ft Version

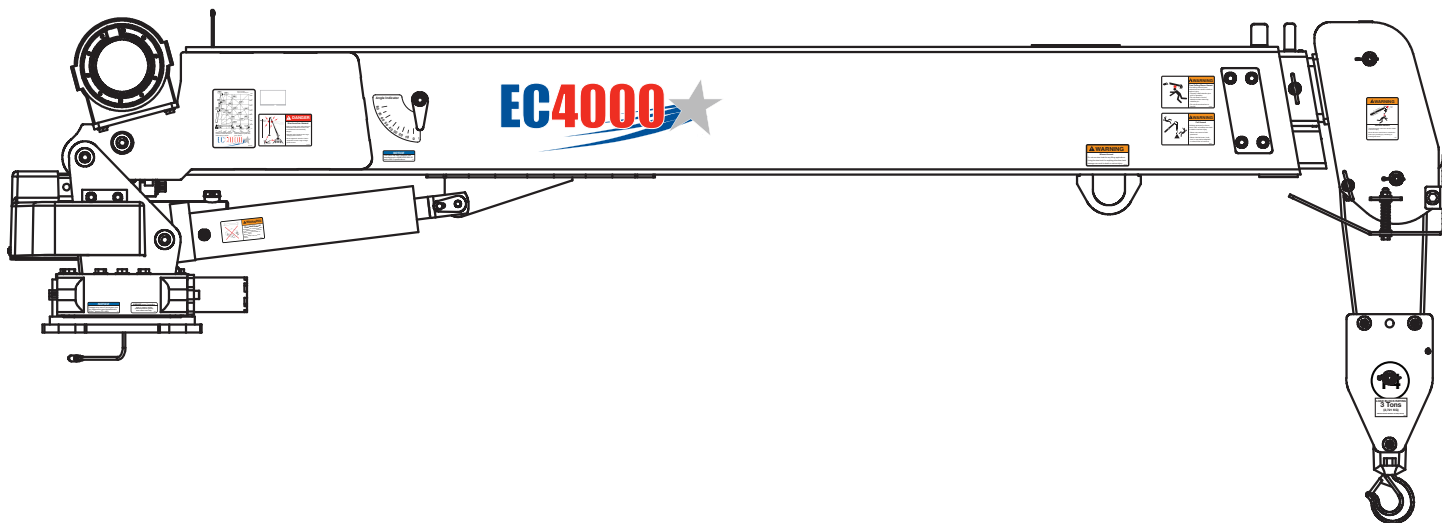

Stellar Industries, Inc.

190 State Street

PO Box 169

Garner, IA 50438

800-321-3741

Fax: 641-923-2811

www.stellarindustries.com

Subject to Change without Notification.
© 2013 Stellar Industries, Inc.

Last Revision: 05/07/13

EC4000 Manual Revisions

Date of Revision	Section Revised	Description of Revision
March 25th, 2013	Chapter 2: Installation Chapter 4: Replacement Parts	Updated Control Kit, Wiring Diagram, and Replacement Parts to reflect engineering changes.

Table of Contents

Chapter 1 - Specifications	1
Capacity Chart - Decal PN 51283.....	2
Chapter 2 - Installation	3
Installation Overview.....	4
Flatbed Body Reinforcement.....	5
EC4000 Mounting Detail	5
EC4000 Installation Drawing	6
Hydraulic Kit - PN 51282	7
Control Kit - PN 42804.....	8
Control Kit (24V Option) - PN 67932	9
EC4000 Wiring Diagram	10
Valve Bank Drawing	11
Stability Procedure	12
Stability Capacity Chart	13
Decal Kit Placement - PN 51286.....	14
Chapter 3 - Assembly Drawings	15
Base Assembly - PN 50054	15
Mast Assembly - PN 50368.....	16
Mast Assembly (24V Option) - PN 67930	17
Main Boom Assembly - PN 50509	18
Main Boom Assembly (24V Option) - PN 67868.....	19
Extension Boom Assembly - PN 50611	20
Cable & Hook Assembly - PN 50492	21
Radio Transmitter Assembly.....	22
Chapter 4 - Replacement Parts	23

Find a Dealer Near You:

<http://www.stellarindustries.com/pages/dist/distsearch.htm>

For Technical Questions, Information, Parts, or Warranty, Call Toll-Free at

800-321-3741

Hours: Monday - Friday, 8:00 a.m. - 5:00 p.m. CST

Or email at the following addresses:

Technical Questions, and Information
Order Parts
Warranty Information

service@stellarindustries.com
parts@stellarindustries.com
warranty@stellarindustries.com

About this manual

A copy of this manual is provided with every crane and can be found in the hard plastic manual case that is installed on the chassis. A copy of this manual shall remain with the crane at all times.

Throughout the manual, three signal words will be used to bring attention to important items:

NOTICE

A NOTICE signal word indicates a practice not related to physical injury.

⚠ WARNING

A WARNING signal word indicates a hazardous situation which, if not avoided, could result in death or serious injury.

⚠ DANGER

A DANGER signal word indicates a hazardous situation which, if not avoided, will result in death or serious injury.

Information contained within this manual does not cover operation, maintenance, or troubleshooting. Please refer to the General EC Series Crane Manual for details on these items.

This manual is not binding. Stellar Industries, Inc. reserves the right to change, at any time, any or all of the items, components, and parts deemed necessary for product improvement or commercial/production purposes. This right is kept with no requirement or obligation for immediate mandatory updating of this manual.

If more information is required or technical assistance is needed, or if you feel that any part of this manual is unclear or incorrect, please contact the Stellar Customer Service Department by phone at 800-321-3741 or email at service@stellarindustries.com.

Chapter 1 - Specifications

Model EC4000-20ft Version Crane SPECIFICATION SHEET

Crane Rating:	16,000 ft-lb (2.21 TM)
Standard Boom Length:	10' (3.05 m) from CL of Crane
Boom Extension:	1st stage: Hydraulic 60" (152.4 cm) 2nd stage: Manual 60" (152.4 cm)
Maximum Horizontal Reach:	20' (6.10 m) from CL of Crane
Maximum Vertical Lift: (from crane base)	21' 3" (6.48 m)
Boom Elevation:	-5 to +80 degrees
Stowed Height: (crane only)	29.53" (75 cm)
Mounting Space Required:	19" x 19" (48.3 x 48.3 cm)
Approximate Crane Weight:	1180 lbs (535 kg)
Controls:	Radio control standard for all functions.
Winch Specifications	
Rope Length:	90 ft (27.4m)
Rope Diameter:	5/16" (.79 cm)
Line pull speed:	16 ft/min (4.88 m/min)
Max. single part line:	2500 lbs (1134 kg)
Max. double part line:	5000 lbs (2268 kg)
Rotation: (worm gear)	410 degree power
Lifting Capacities:	4000 lbs @ 4' (1814 kg @ 1.22 m) 1065 lbs @ 15' (480 kg @ 4.57 m) 800 lbs @ 20' (360 kg @ 6.1 m)
Power Supply Required:	12 volt power unit (2.0 gpm @ 2300 psi) (7.57 lpm @ 159 bars)

*Subject to change without notification

Capacity Chart - Decal PN 51283

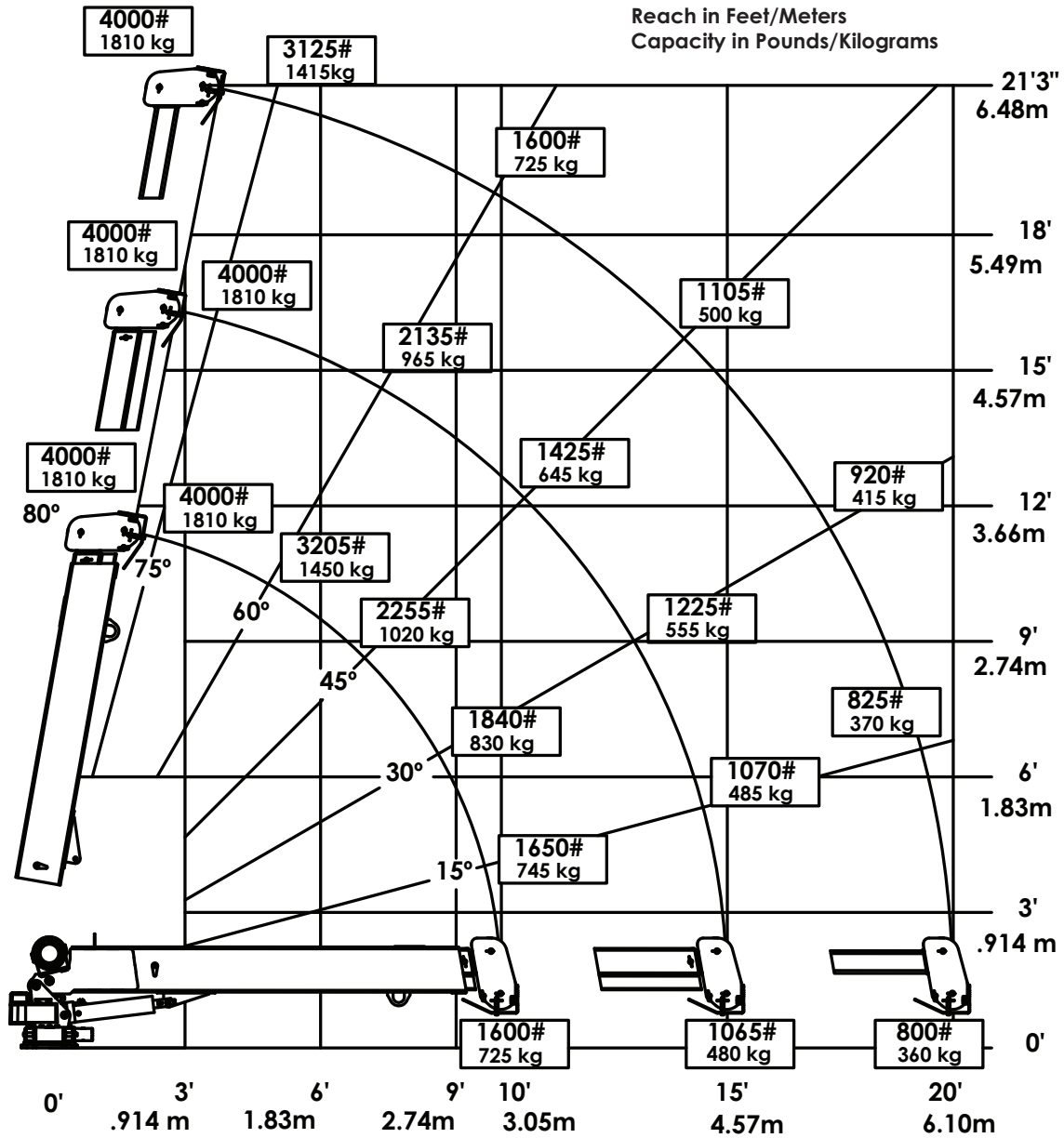

Weight of load handling devices are part of the load lifted and must be deducted from the capacity.

Maximum 1 - part line capacity is 2000lbs (905kg). For greater loads, use 2 - part line.



Chapter 2 - Installation

General Installation

This chapter is designed to serve as a general guide for the installation of a Stellar EC4000 Crane on a Stellar Service Body. Each installation is considered unique so certain portions of this chapter may or may not apply to your direct application. If a question should arise during the installation process, please contact Stellar Customer Service at (800) 321 3741.

This crane is designed for use with a Stellar Service Body installed on a vehicle that meets the minimum chassis requirements of the crane. It is the installer's responsibility to assure that the crane is mounted on a platform that will support the maximum crane rating of this crane.

⚠ WARNING Do not install this crane on a body not capable of handling the loads imposed on it. Failure to do so may result in serious injury or death.

NOTICE When installing welder units to the service bodies, it is highly recommended that a surge protector is installed on the chassis batteries to protect the crane radio receiver, wiring and other electronic devices from an unexpected electrical spike or surge. Failure to do so could result in extensive damage to the service body and crane electrical circuit.

Installation Notice

According to Federal Law (49 cfr part 571), each final-stage manufacturer shall complete the vehicle in such a manner that it conforms to the standards in effect on the date of manufacture of the incomplete vehicle, the date of final completion, or a date between those two dates. This requirement shall, however, be superseded by any conflicting provisions of a standard that applies by its terms to vehicles manufactured in two or more stages.

Therefore, the installer of Stellar cranes and bodies is considered one of the manufacturers of the vehicle. As such a manufacturer, the installer is responsible for compliance with all applicable federal and state regulations. They are required to certify that the vehicle is in compliance with the Federal Motor Vehicle Safety Standards and other regulations issued under the National Traffic and Motor Vehicle Safety Act.

Please reference the Code of Federal Regulations, title 49 - Transportation, Volume 5 (400-999), for further information, or visit <http://www.gpoaccess.gov/nara/index.html> for the full text of Code of Federal Regulations.

Installation Overview

1. Determine that the mounting location for the EC4000 crane is at least 19" x 19" (48.3 x 48.3 cm).
2. Use the detail on the following page to drill .938" diameter holes into the mounting plate. Run tap on the threads of the base to be sure they are clean.
3. Use a crane or lifting device capable of lifting the weight of the Stellar crane. The Stellar EC4000 weighs approximately 1180 lbs (535 kg). **Note: cranes are shipped with rotation positioned at 180 degrees from normal stowed travel position.** This will allow for easy installation of the crane and permanent connection of all hydraulic and electrical components prior to repositioning into the crane saddle.
4. Connect straps or chain from the lifting device to the main boom of the Stellar EC4000.
5. Use four (4) 7/8" x 2" Grade 9 bolts and four (4) 7/8" Grade 9 flat washers.
6. Install a washer on each bolt.
7. Apply Loctite Thread locker #277 to the bolts.
8. Using the lifting device, lower the Stellar EC4000 just above the crane compartment and start the bolts. Have someone assist in leveling the crane.
9. Secure the crane using the mounting hardware provided. **Note: longer or shorter bolts may be required – recommended thread engagement into crane base is 0.75" – use grade 9, zinc plated bolts only.**
10. Torque the bolts to 549 ft-lbs.
11. Remove supporting crane.
12. Hook-up hydraulics and electrical using the schematics provided at the end of this chapter.

Note: If questions should arise during any portion of this installation, please contact Stellar Customer Service at (800) 321-3741.

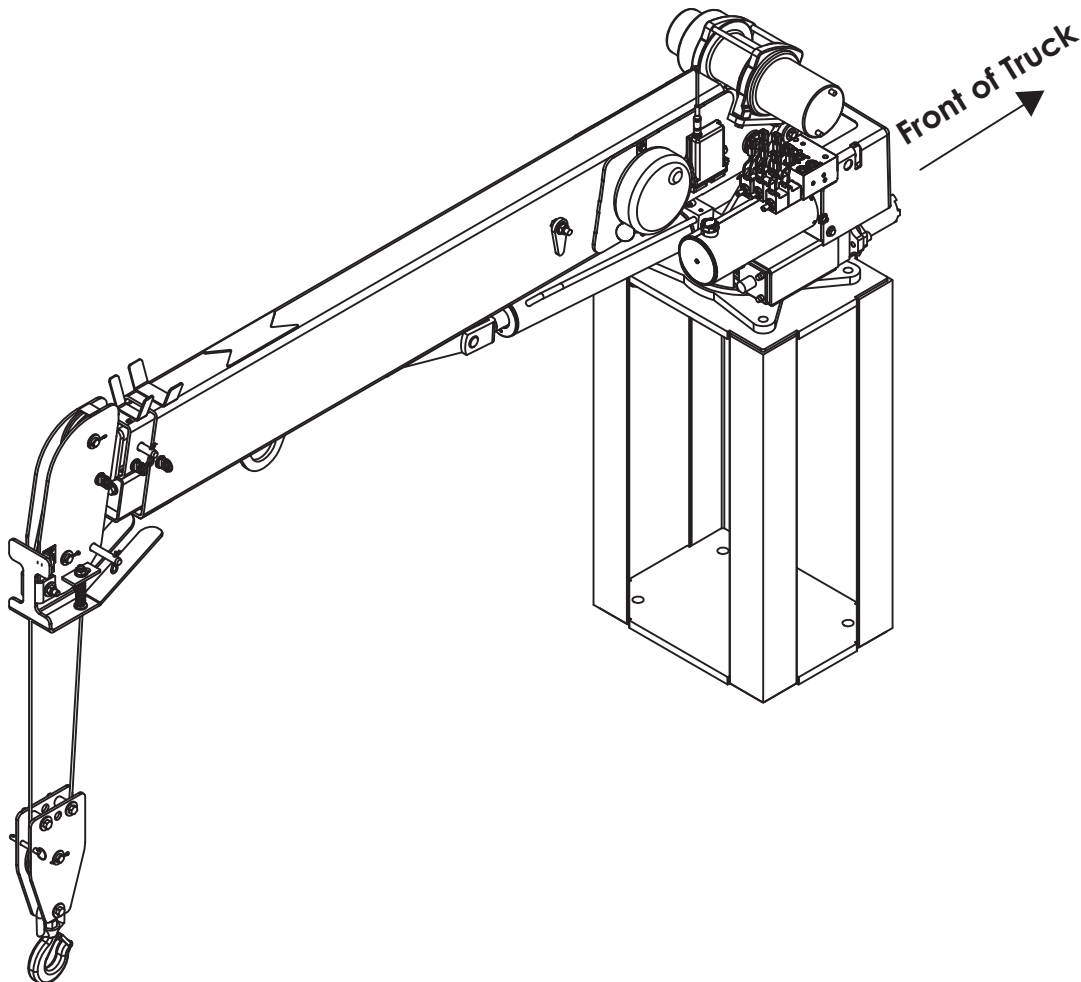

EC4000 Mounting Detail

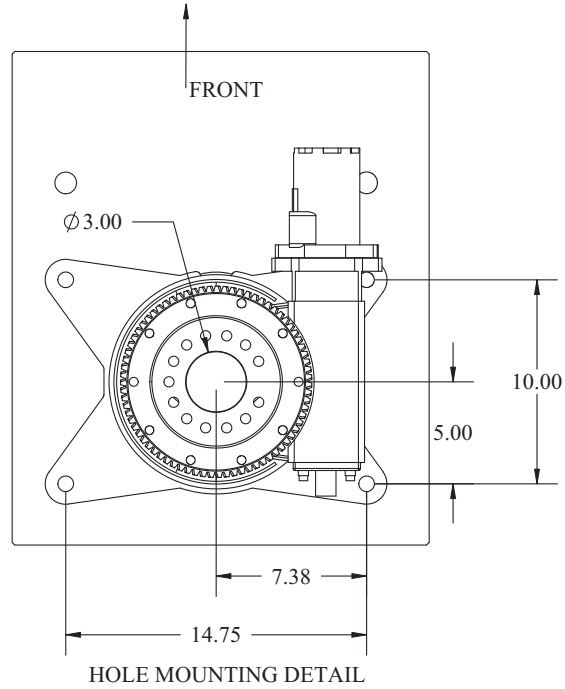

Flatbed Body Reinforcement

If it has been determined that the destination body won't support the crane with a fully rated load, the body must be reinforced. Use 1/4" fillet welds and an AWS qualified welder to proceed as shown in this drawing:

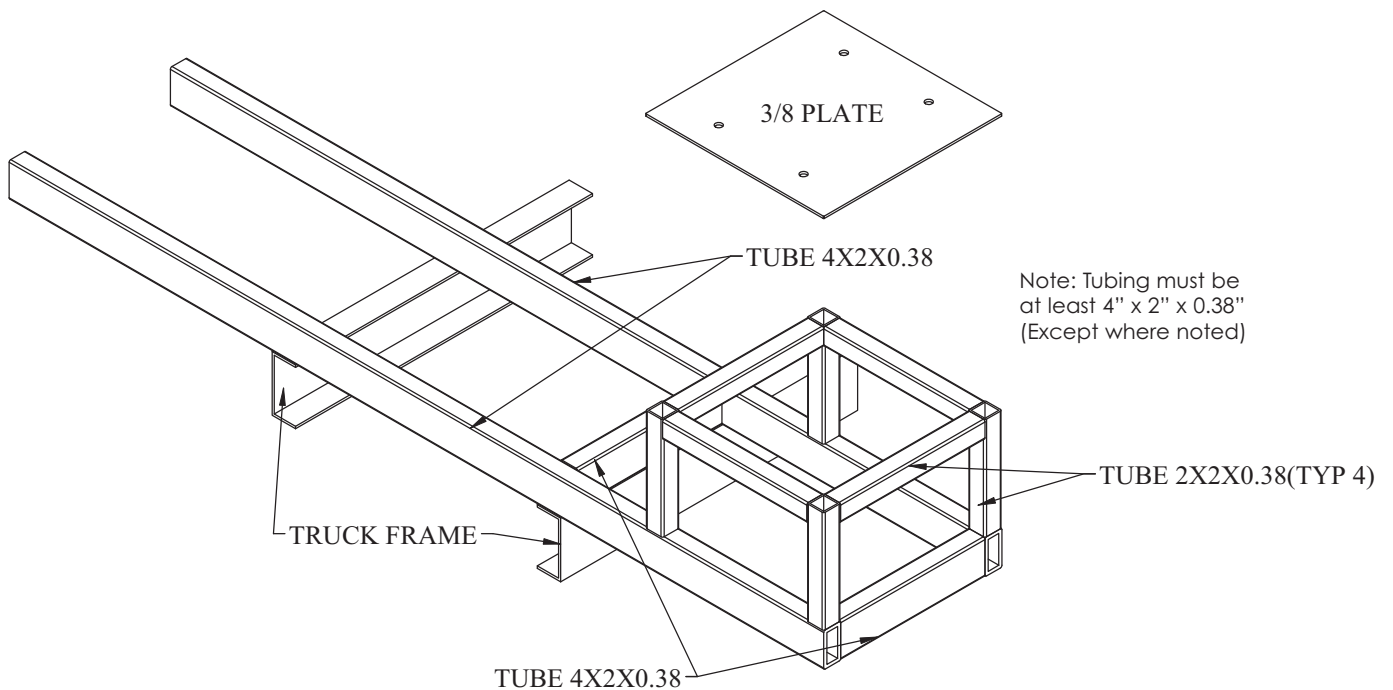

EC4000 Installation Drawing

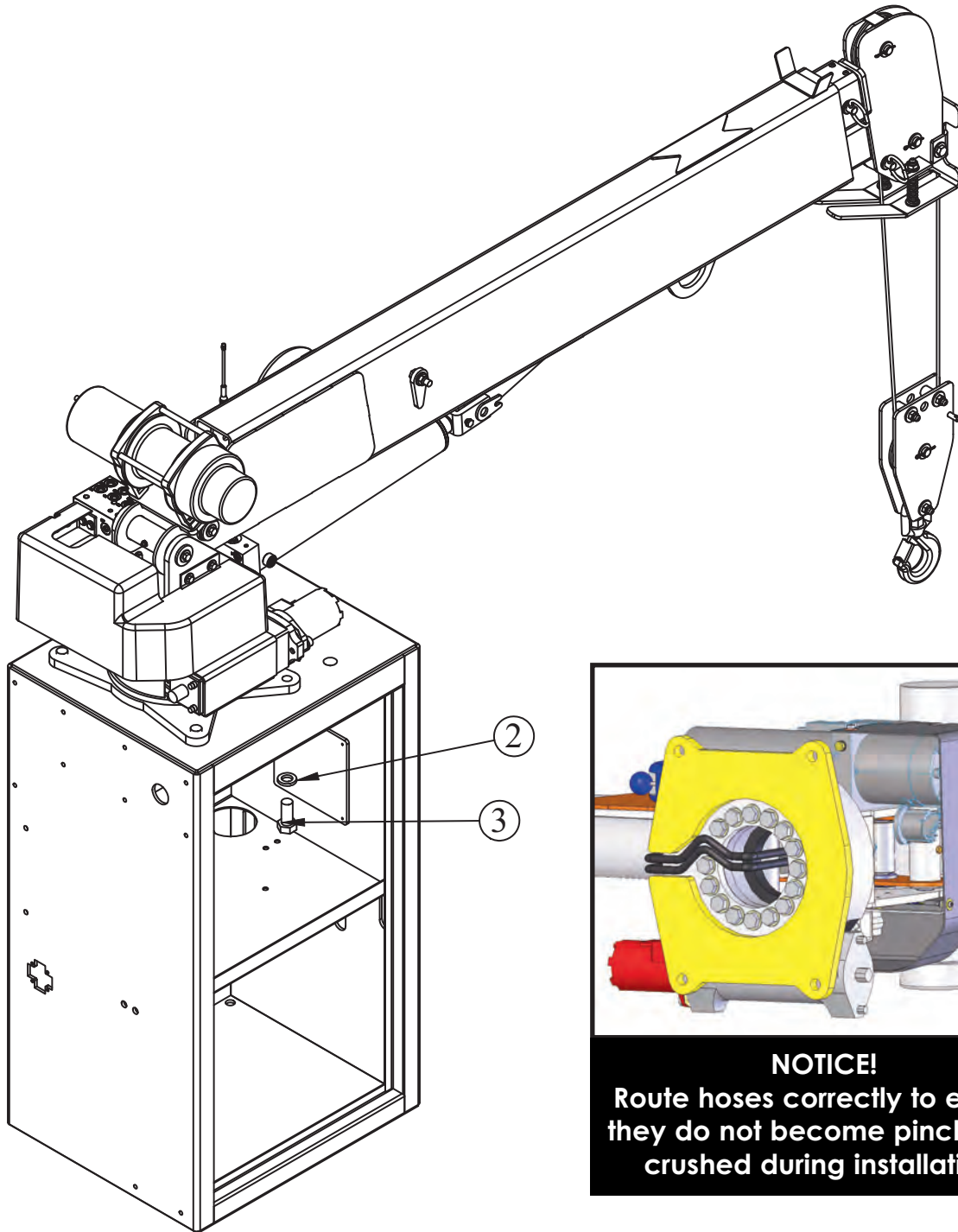

Stowed Position

ITEM	PART	DESCRIPTION	QTY.
2	18041	WASHER 0.88 SAE FLAT YELLOW GR9	4
3	51377	CAP SCR 0.88-9X2.00 HHGR9	4

NOTE:
STABILITY DECAL P/N 16881 IS PART OF THIS KIT

Hydraulic Kit - PN 51282

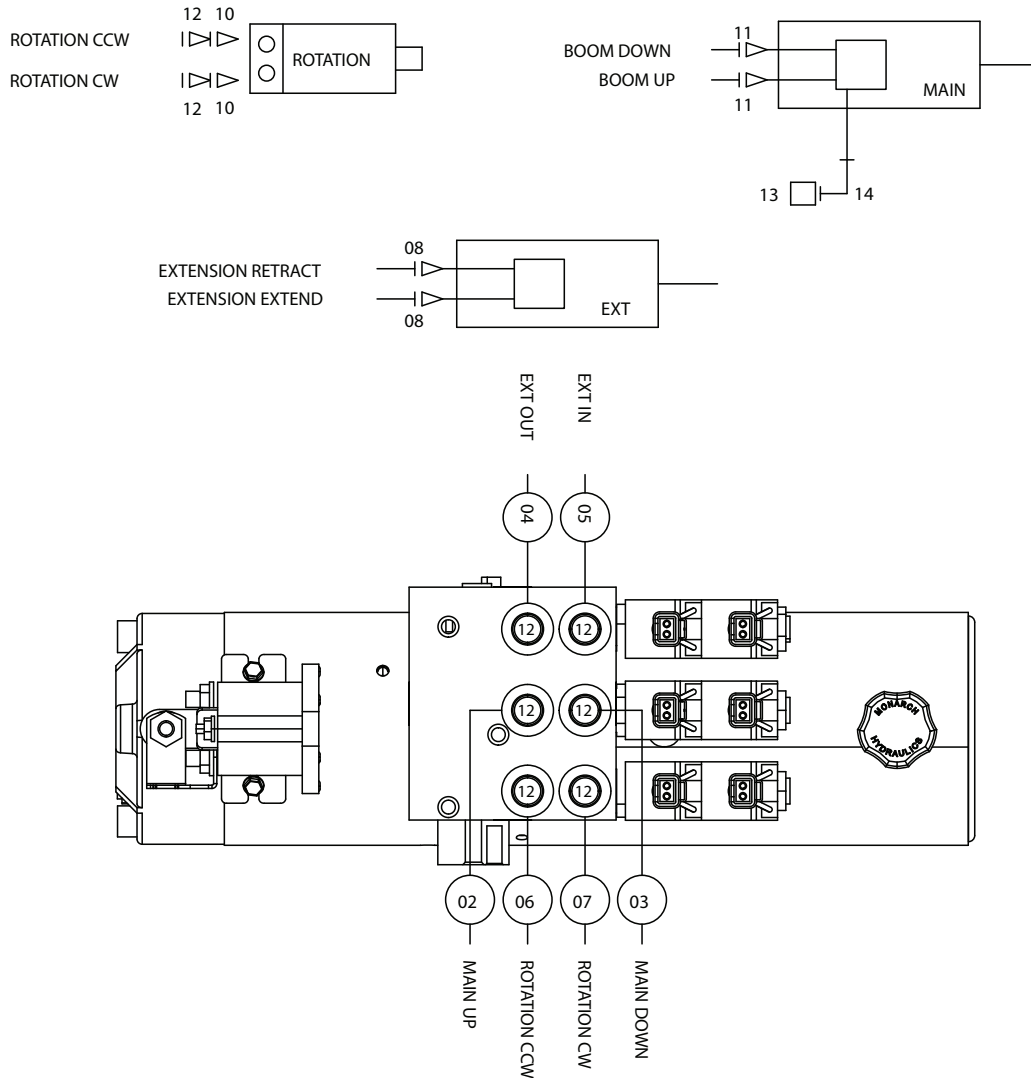

PN 51282

16			
15			
14	3861	FTG ML FM O'RING 90 DEG	1
13	49314	SWITCH PRES OVERLD CD-11C-2600R/WD	1
12	C4922	FTG ADAPT 4-6 F5OLO-S	8
11	D1291	FTG ADAPT 4-F5OLO-S	2
10	C1111	FTG ADAPT MSTR/FSTR 10-6 F5OG5	2
09			
08	C5572	FTG ORFS/OBR 45 DG ELL 4-V5OLO	2
07	42984	HOSE-HYD .25X 43	1ref
06	42982	HOSE-HYD .25 X 42	1ref
05	43847	HOSE-HYD .25 X 20	1ref
04	42981	HOSE-HYD .25 X 19	1ref
03	42983	HOSE-HYD .25 X 23	1ref
02	42980	HOSE-HYD .25 X 22	1ref
01	42800	HOSE KIT 3315 CRANE (incl:2-11)	1
ITEM	PART No.	DESCRIPTION	QTY

Control Kit - PN 42804

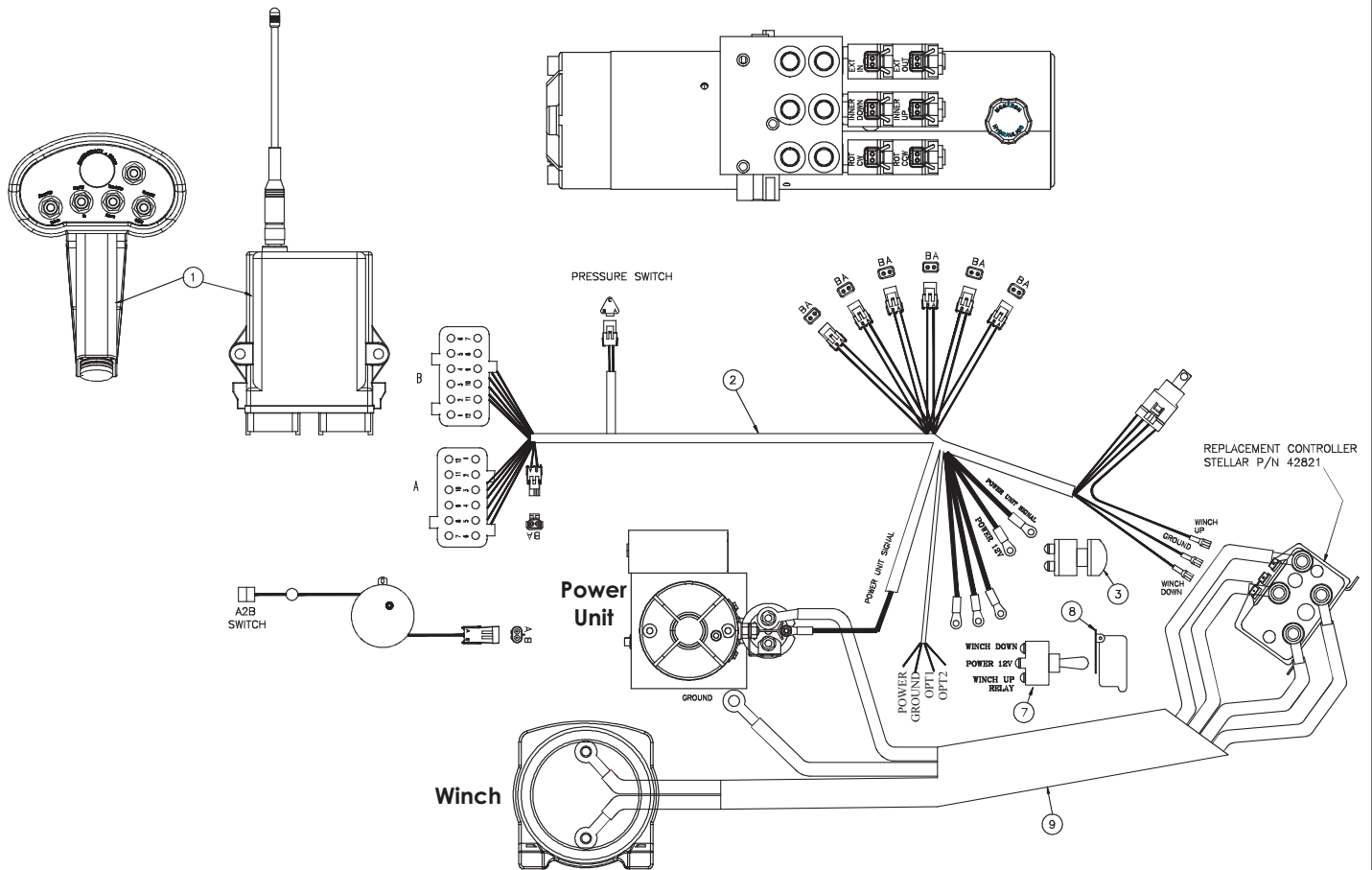

PN 42804

09	47092	WIRE HARNESS EC3200 CONTROLLER	1
08	47409	COVER SWITCH EC3200	1
07	47410	SWITCH MOM SPST 20A	1
06			
05			
04			
03	17771	SWITCH PUSH BUTTON 9216-03	1
02	42805	WIRE HARNESS EC3200	1
01	39784	RADIO CNTRL ASM 5 FCTN ON/OFF	1
ITEM	PART No.	DESCRIPTION	QTY

NOTE: P/N 47092 INCLUDES HARNESS & WINCH CONTROLLER

Control Kit (24V Option) - PN 67932

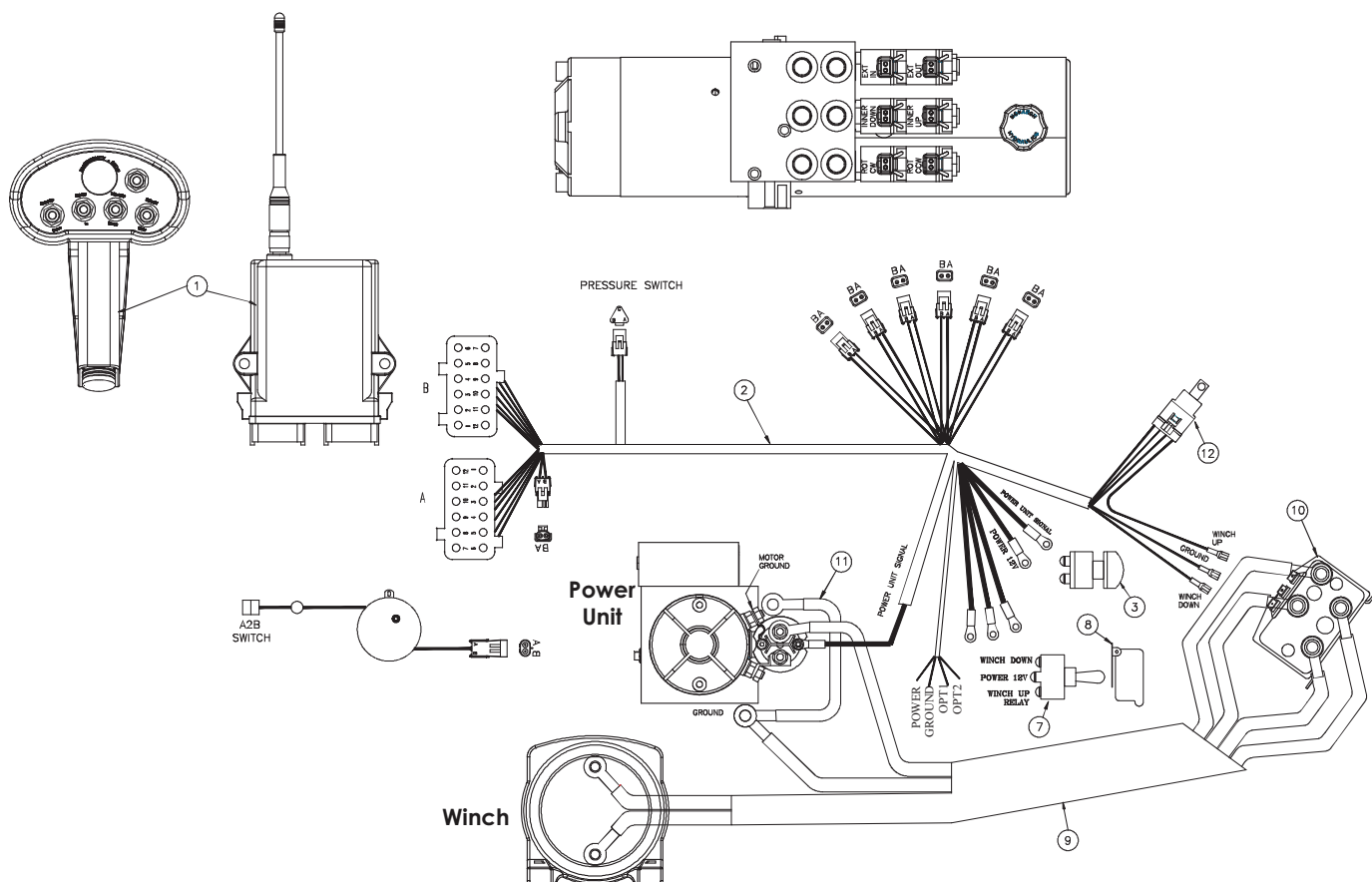

PN 67932

NOTE: 12V CONTROLLER P/N 42821 IS PART OF HARNESS 47092.
 FOR 24V OPTION CONTROLLER IS REPLACED WITH P/N 67867 AND 12V
 RELAY MUST BE REPLACED WITH P/N 58298 (ITEM 12).

12	58298	RELAY BOSCH 24V STANDARD	1
11	36176	CABLE ASM #4 16IN BLACK	1
10	67867	CONTROLLER 24V WARN 34968	1
09	47092	WIRE HARNESS EC3200 CONTROLLER	1
08	47409	COVER SWITCH EC3200	1
07	47410	SWITCH MOM SPST 20A	1
06			
05			
04			
03	17771	SWITCH PUSH BUTTON 9216-03	1
02	42805	WIRE HARNESS EC3200	1
01	39784	RADIO CNTRL ASM 5 FCTN ON/OFF	1
ITEM	PART No.	DESCRIPTION	QTY

EC4000 Wiring Diagram

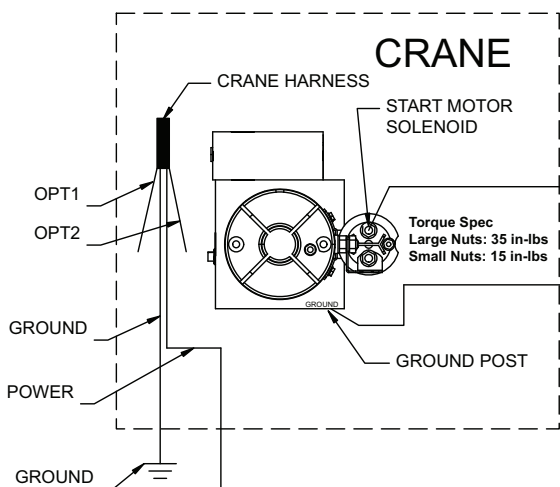
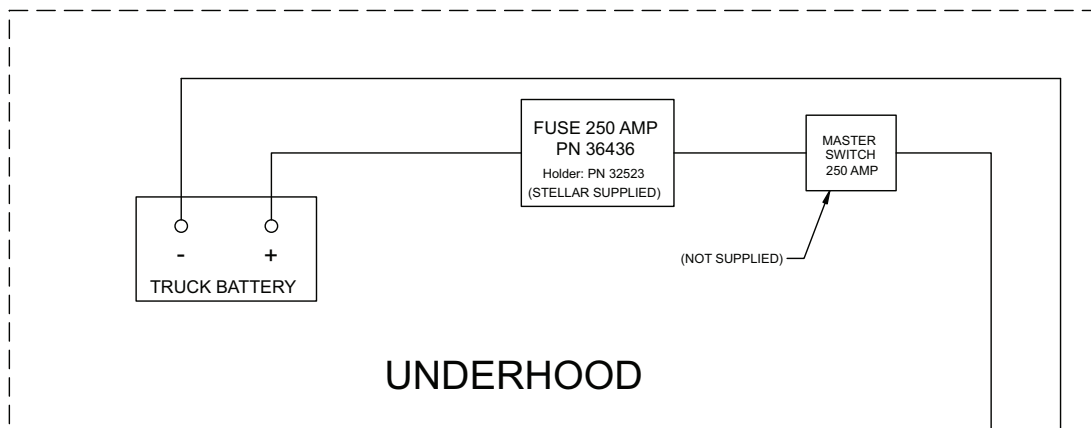

FUSE 250 AMP
PN 36436
Holder: PN 32523
(STELLAR SUPPLIED)

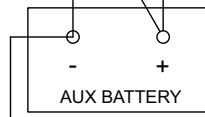

LOCATE AUX BATTERY AS CLOSE TO CRANE AS POSSIBLE

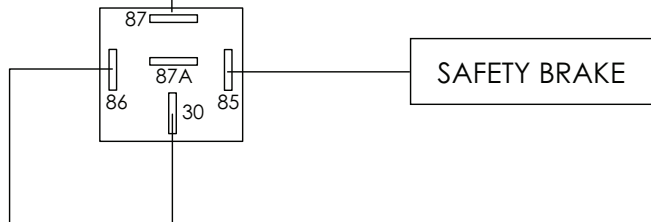

NOTICE Operating the crane without the truck engine running could allow the truck battery to be discharged below levels required for starter cranking power.

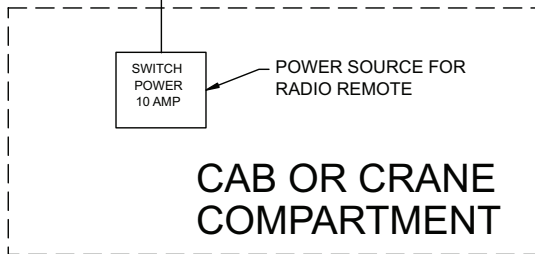

Minimum Wire Sizes:
 EC3200 - #2
 EC4000 - #2
 EC5000 - #2
 EC6000 - 1/0

Valve Bank Drawing

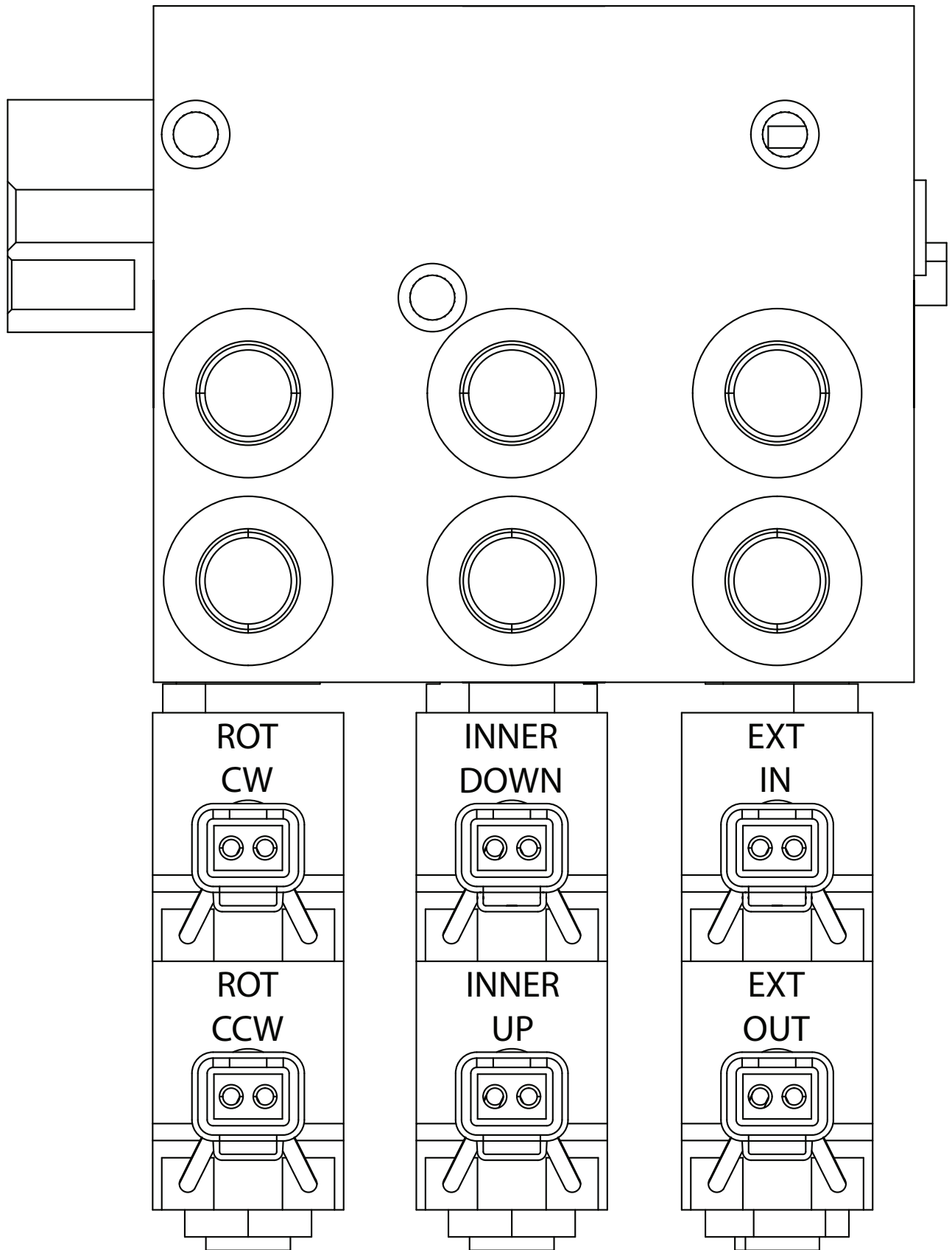

Stability Procedure

Definition of Stability for the Stellar Telescopic Crane Products:

A truck is stable until the load cannot be lifted off the ground with the winch, without tipping over the truck. Every Stellar crane installed must be tested for stability to determine the actual load capacity of the final truck package. The actual test data must be recorded and supplied with the truck at the time of in-service and should be kept with the truck at all times. The following procedure will test the truck package for stability and will provide a stability capacity chart. The load limit information shown on the stability capacity chart is formulated on 85% tipping.

Set Up:

1. Locate the truck on a test course in position for loading and engage travel brakes.
2. Set stabilizers so that they make contact with firm, level footings.
3. Operate the crane under partial load to assure operator proficiency and proper machine function.

EC4000-20ft Version Stability Data

Max Horizontal Reach: 240" (From the center of rotation to boom tip)
Stability Test Weight: 945 lbs.

Test Procedure

1. Rotate the crane into Zone 1 position.
2. With the crane fully retracted and the boom horizontal, winch the test weight off the ground. Note: Keep weight within six inches of the ground at all times.
3. Extend the boom outward until full extension has been reached or until the truck becomes unstable (Again, use the winch to keep the weight within six inches of the ground.)
4. If the boom goes full extension without becoming unstable, the crane is termed stable for this zone and 100% can be written in the Zone 1 data box.
5. If the truck becomes unstable prior to going full extension, retract the boom until the truck becomes stable and measure the horizontal reach in this position (center of rotation to boom tip). This is the stable horizontal reach for this zone. Stable horizontal reach divided by Maximum horizontal reach multiplied by 100 equals the percentage of rated capacity for this zone. Use the following formula to determine the percentage of rated capacity:

$$\frac{\text{Stable Horizontal Reach}}{\text{Max Horizontal Reach}} \times 100 = \text{Percentage of Rated}$$

6. Record this number in the data box for Zone 1. This is the revised capacity due to stability for this zone.
7. Repeat this procedure for each zone until the worksheet is completed.
8. This is the revised capacity based on stability of this package.

Stability Capacity Chart

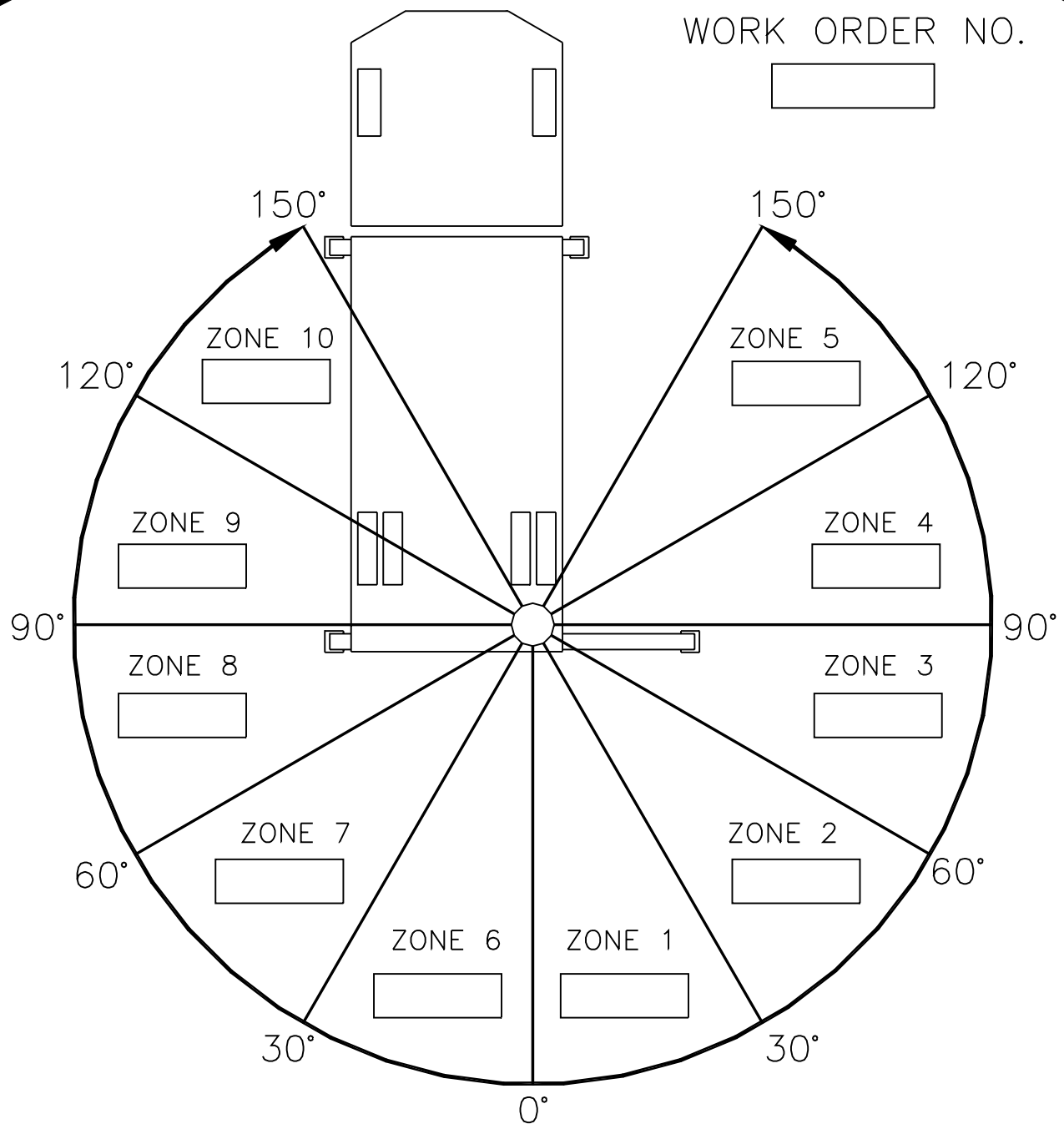

BOXES TO BE FILLED IN WITH PERCENTAGE OF RATED CAPACITY IN THE APPROPRIATE REGION.

STABILITY CAPACITY CHART

STABILITY is based on this specific truck package.

Decal Kit Placement - PN 51286

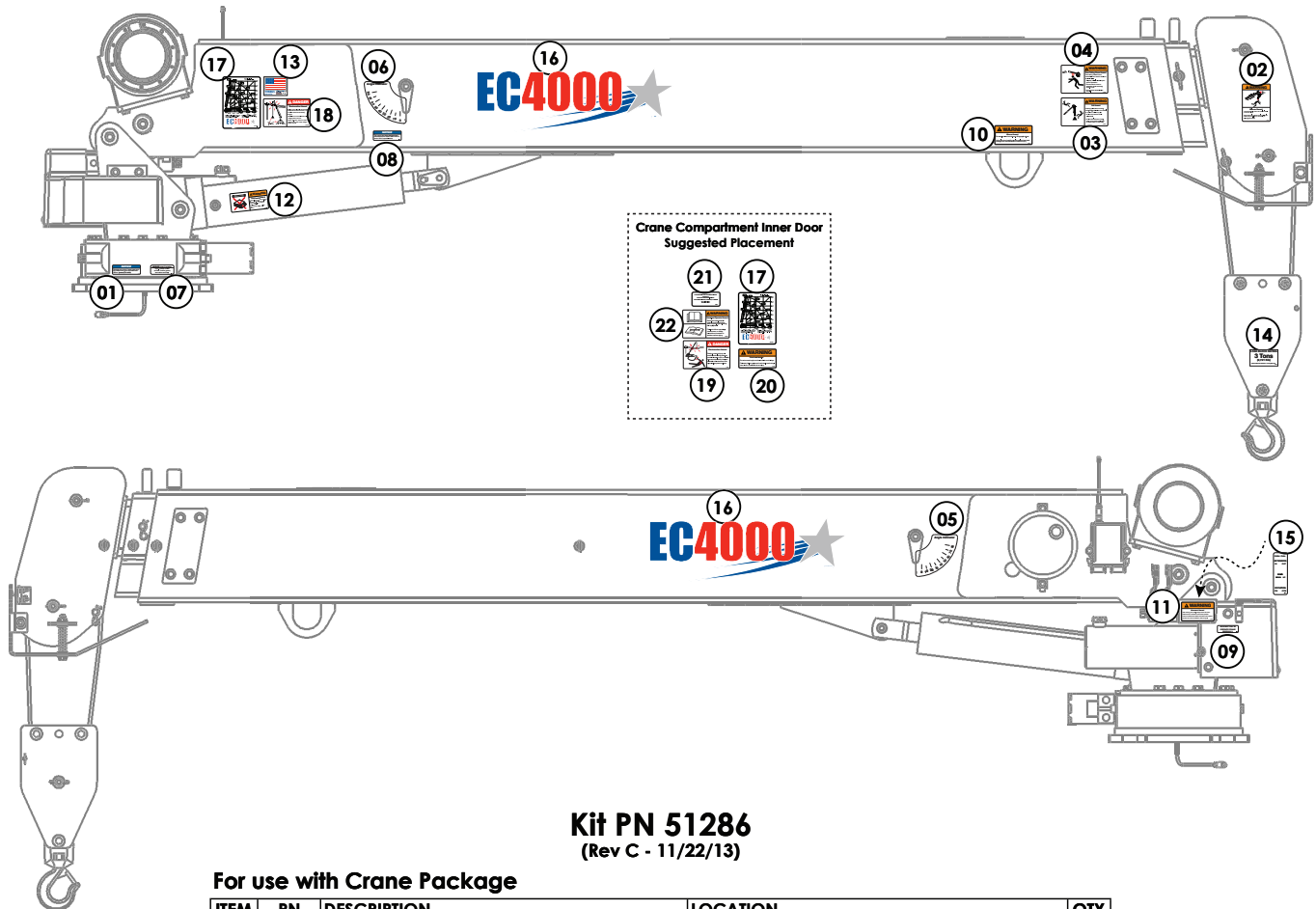

Kit PN 51286 (Rev C - 11/22/13)

For use with Crane Package

ITEM	PN	DESCRIPTION	LOCATION	QTY
01	9188	DECAL ROTATE/GREASE	Crane Base	1
02	12300	DECAL WARNING TWO BLOCKING	Crane Horse Head	1
03	12451	DECAL WARNING HOISTING PERSONNEL	Main Boom	1
04	12452	DECAL WARNING MANUAL EXT	Main Boom	1
05	13819	DECAL ANGLE INDICATOR SS	Main Boom	1
06	13820	DECAL ANGLE INDICATOR CS	Main Boom	1
07	15171	DECAL GREASE WORM	Crane Base	1
08	15172	DECAL ASME/ANSI B30.22/B30.5	Main Boom	1
09	18472	DECAL MANUAL OPERATION	On top of valve bank	1
10	24712	DECAL WARNING STOW HOOK	Crane Boom above stow hook	1
11	25159	DECAL WARNING MANUAL OVERRIDES	Valve Bank	1
12	28256	DECAL WARNING OVERLOAD DEVICE	Main Cylinder	1
13	35234	DECAL STELLAR MADE IN THE USA	Main Boom	1
14	42819	DECAL SNATCH BLOCK 3 TON	Snatch Block	1
15	42820	DECAL VB CONTROL EC SERIES	On top of valve bank	1
16	50495	DECAL IDENTIFICATION EC4000	Main Boom (Both Sides)	2
17	51283	DECAL CAPACITY EC4000-20	Main Boom and Crane Compartment	2
18	C1179	DECAL DANGER ELECTROCUTION SMALL	Main Boom	1

For use with Body/Chassis Package

ITEM	PN	DESCRIPTION	LOCATION	QTY
19	4186	DECAL DANGER ELECTROCUTION REMOTE	Crane Compartment	1
20	4189	DECAL WARNING OVERLOAD	Crane Compartment	1
21	4214	DECAL SERVICE	Crane Compartment	1
22	68024	DECAL WARNING UNTRAINED OPERATOR	Crane Compartment	1
23*	C4545	DECAL DANGER ELECTROCUTION LARGE	Four corners of the body/chassis	4
24*	C5910	DECAL STELLAR 4x9.5	Suggested: Rear body/tailgate	1
25*	C5911	DECAL STELLAR 2x4.5	Suggested: Side corners of body	3

*Not Shown

Chapter 3 - Assembly Drawings

Base Assembly - PN 50054

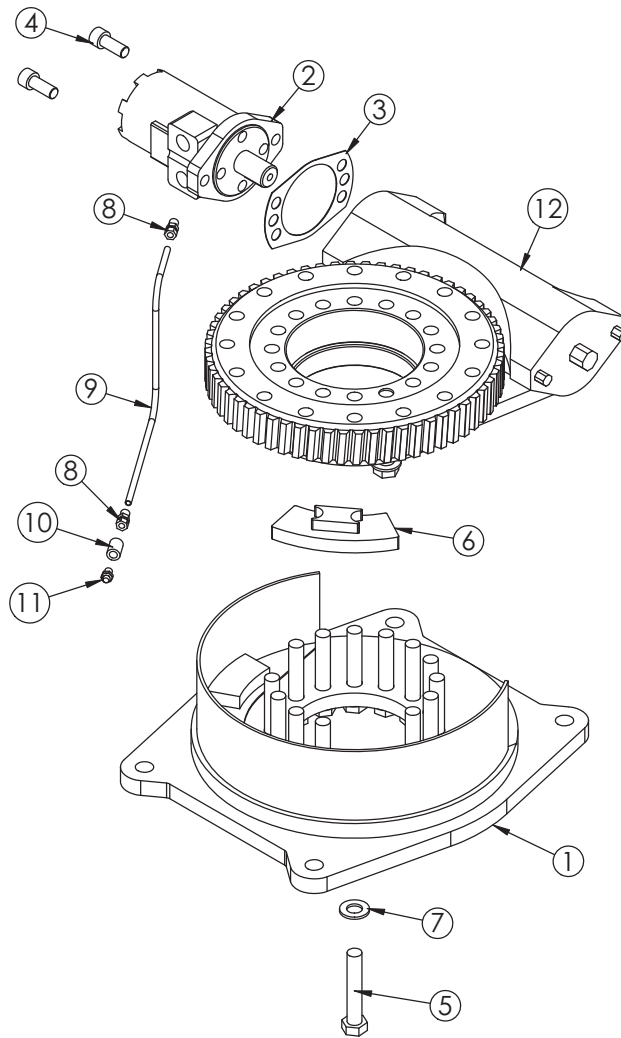

PN 50054

ITEM	PART	DESCRIPTION	QTY.
1	50055	BASE EC4000	1
2	D1204	ROTATION MOTOR 5520	1
3	21151	GASKET MOTOR 008-10056-1	1
4	D1307	CAP SCR 0.50-13X1.25 SH	2
5	51284	CAP SCR 0.63-11X3.50 HHGR9	15
6	50060	STOP SLIDING EC4000	1
7	16733	WASHER 0.63 FLAT GR9	15
8	D1345	FTG CPRSN 0.12NPT/0.25 TUBE	2
9	D1810	TBE AIR SAEJ844 TYPE A .25 (RM)	1
10	C2256	FTG COUPLER PIPE 0.13	1
11	56589	ZERK 1/8 NPT STRAIGHT LONG THREAD	1
12	50228	BEARING SWING DRIVE 170-00018-1	1

MOTOR GASKET SHOWN AS REFERENCE ONLY

Mast Assembly - PN 50368

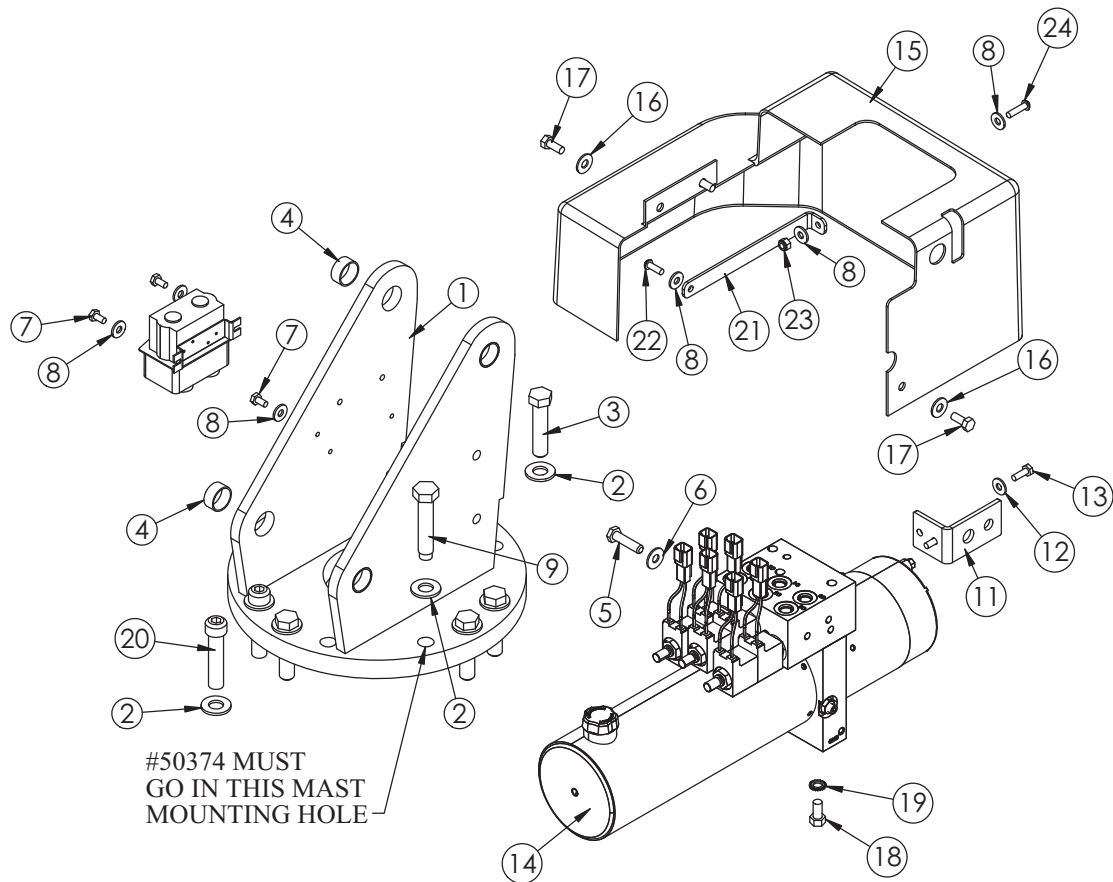

PN 50368

ITEM	PART	DESCRIPTION	QTY.
1	50369	MAST EC4000	1
2	C5902	WASHER 0.63 SAE FLAT YELLOW GR8	12
3	50375	CAP SCR 0.63-11X2.75 HHGR8	9
4	20362	BUSHING IGUS GF1-1618-08	4
5	0345	CAP SCR 0.38-16X1.50 HHGR5	2
6	0346	WASHER 0.38 FLAT	2
7	0478	CAP SCR 0.25-20X0.50 HHGR5	3
8	D0917	WASHER 0.25 FLAT SS	6
9	50374	CAP SCR 0.63-11X3.09 MOD EC4000	1
11	47411	BRKT OVERRIDE BUTTON EC3200	1
12	0340	WASHER 0.25 FLAT	2
13	0479	CAP SCR 0.25-20X0.75 HHGR5	2
14	42513	POWER UNIT 12V EC3200	1
15	44475	COVER EC3200 HDPE	1
16	0343	WASHER 0.31 USS FLAT ZINC	3
17	0420	CAP SCR 0.31-18X0.75 HHGR5	3
18	0492	CAP SCR 0.38-16X0.75 HHGR5	1
19	5870	WASHER 0.38 STAR EXTERNAL	1
20	51281	CAP SCR 0.63-11X2.75 SHSS	2
21	51896	BRKT COVER EC CRANES	1
22	C6021	CAP SCR 0.25-20X0.75 BTNHD SS	1
23	30659	NUT 0.25-20 HH NYLOC SS	1
24	C6022	CAP SCR 0.25-20X1.00 BTNHD SS	1

NOTE:
WINCH CONTROLLER
SHOWN FOR REFERENCE ONLY

Mast Assembly (24V Option) - PN 67930

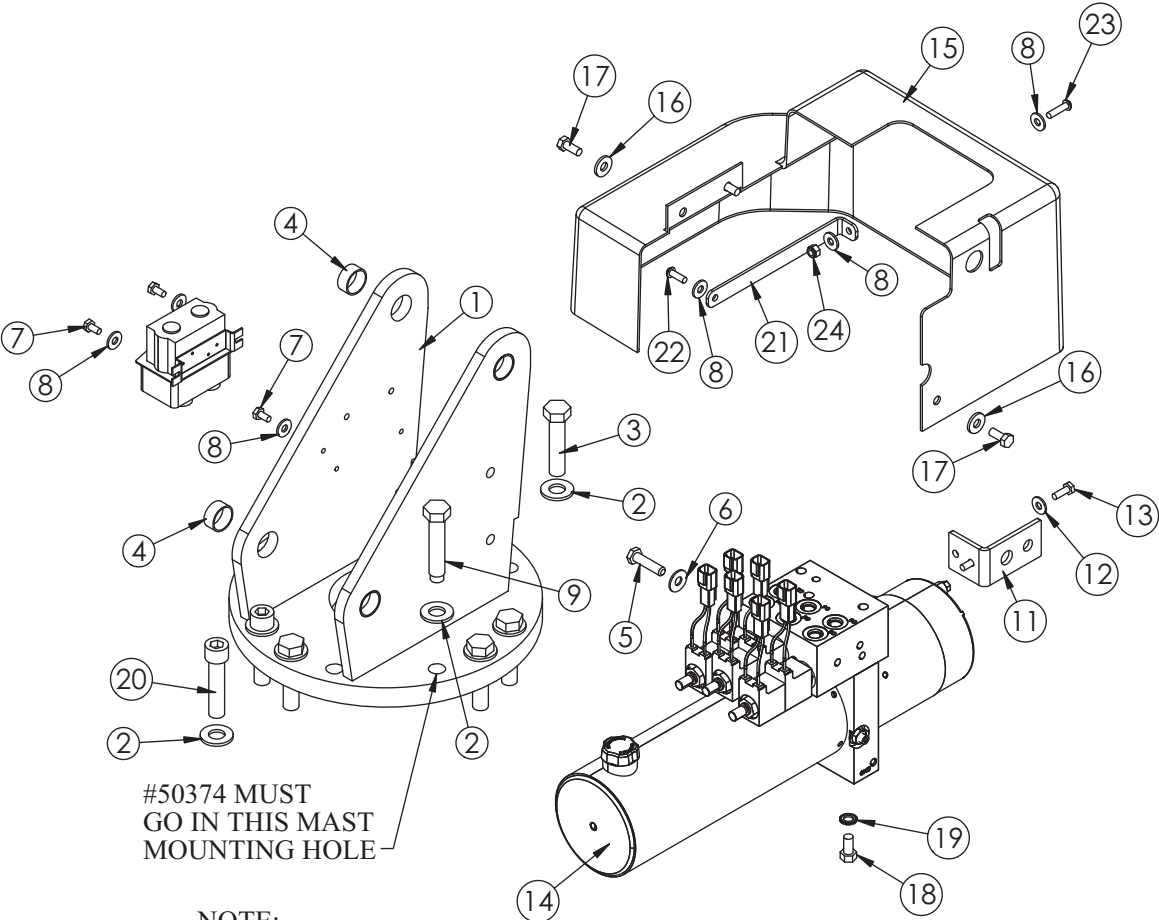

#50374 MUST GO IN THIS MAST MOUNTING HOLE

NOTE:
WINCH CONTROLLER
SHOWN FOR REFERENCE ONLY

PN 67930

ITEM	PART	DESCRIPTION	QTY.
1	50369	MAST EC4000	1
2	C5902	WASHER 0.63 SAE FLAT YELLOW GR8	12
3	50375	CAP SCR 0.63-11X2.75 HHGR8	9
4	20362	BUSHING BPC16DXR08 1.00X.50	4
5	0345	CAP SCR 0.38-16X1.50 HHGR5	2
6	0346	WASHER 0.38 FLAT	2
7	0478	CAP SCR 0.25-20X0.50 HHGR5	3
8	D0917	WASHER 0.25 FLAT SS	6
9	50374	CAP SCR 0.63-11X3.09 MOD EC4000	1
11	47411	BRKT OVERRIDE BUTTON EC3200	1
12	0340	WASHER 0.25 FLAT	2
13	0479	CAP SCR 0.25-20X0.75 HHGR5	2
14	67931	POWER UNIT 24V EC CRANES	1
15	44475	COVER EC3200 HDPE	1
16	0343	WASHER 0.31 USS FLAT ZINC	3
17	0420	CAP SCR 0.31-18X0.75 HHGR5	3
18	0492	CAP SCR 0.38-16X0.75 HHGR5	1
19	5870	WASHER 0.38 STAR EXTERNAL	1
20	51281	CAP SCR 0.63-11X2.75 SHSS	2
21	51896	BRKT COVER EC CRANES	1
22	C6021	CAP SCR 0.25-20X0.75 BTNHD SS	1
23	C6022	CAP SCR 0.25-20X1.00 BTNHD SS	1
24	30659	NUT 0.25-20 HH NYLOC SS	1

Main Boom Assembly - PN 50509

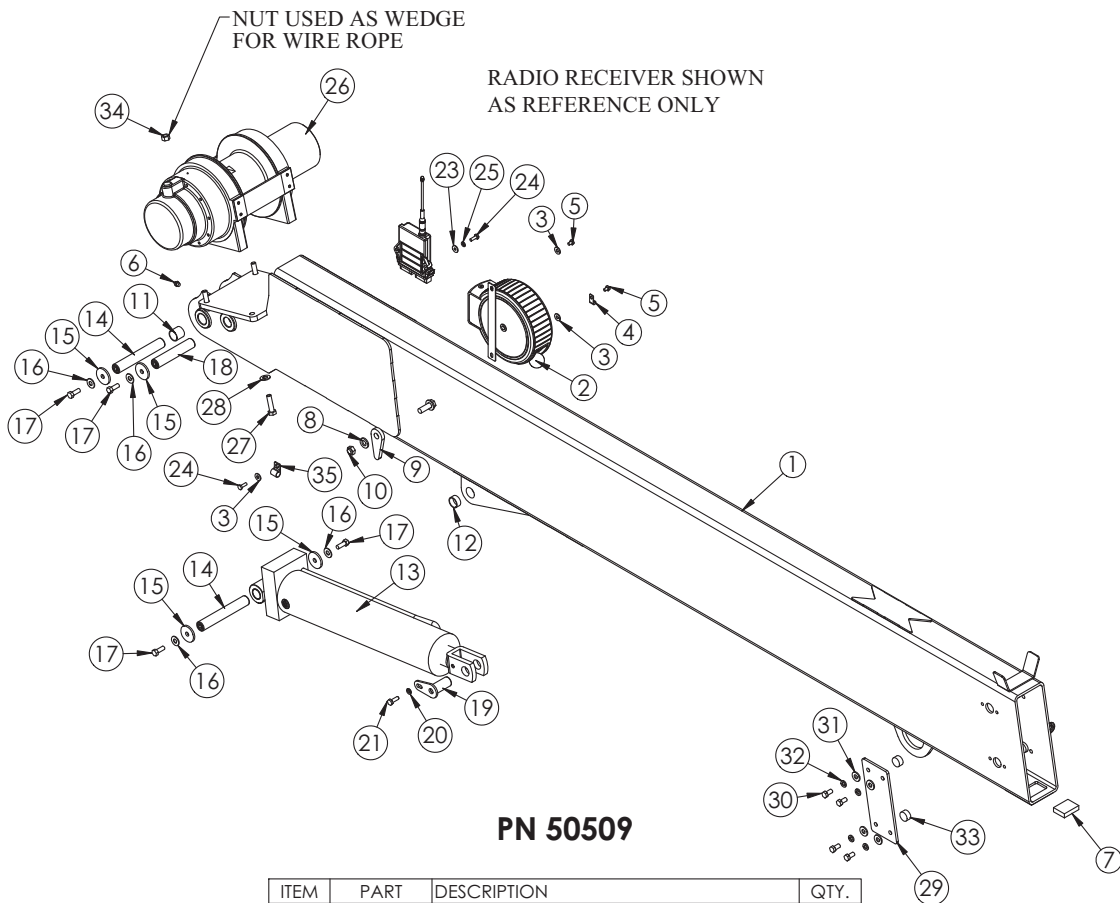

ITEM	PART	DESCRIPTION	QTY.
1	50510	INNER BOOM EC5000	1
2	72602	CORD REEL ASM 21 FT CRANE	1
3	0340	WASHER 0.25 FLAT	3
4	C5606	CLAMP 0.25 BLK VINYL	1
5	43845	CAP SCR 0.25-20X0.38 HHGR5	2
6	c1592	ZERK 1/8 NPT STRAIGHT	1
7	42508	WEAR PAD 0.50X1.50X2.00	1
8	D0790	WASHER 0.50 FLAT GR8	4
9	13815PC	PLATE ANGLE INDICATOR	2
10	C6106	NUT 0.50-13 HHGR5 NYLOC	2
11	0069	BUSHING QSI-1618-16	2
12	20362	BUSHING BPC16DXR08 1.00X.50	1
13	50609	CYLINDER 4.00X13.00	1
14	42515ZP	PIN 1.00X6.38 D&T	2
15	9320	PIN CAP 0.44X1.75X0.19 SS	6
16	C6353	WASHER 0.38 FLAT GR8	6
17	13573	CAP SCR 0.38-16X1.00 HHGR8	6
18	42516ZP	PIN 1.00X5.13 D&T	1
19	42517ZP	PIN TEAR DROP 1.00X2.19	1
20	5591	WASHER 0.31 SAE FLAT YELLOW GR8	1
21	21170	CAP SCR 0.31-18X1.00 HHGR8	1
23	D0917	WASHER 0.25 FLAT SS	2
24	0479	CAP SCR 0.25-20X0.75 HHGR5	3
25	0521	WASHER 0.25 LOCK	2
26	50226	WINCH 2500DC WARN	1
27	50111	CAP SCR 12MMX45MM HHGR8	4
28	42788	WASHER 0.44 SAE FLAT YELLOW GR8	4
29	51168PC	COVER WEAR PAD EC5000	2
30	0492	CAP SCR 0.38-16X0.75 HHGR5	8
31	0346	WASHER 0.38 USS FLAT ZINC	8
32	0523	WASHER 0.38 LOCK	8
33	51169	WEAR PAD 0.50X1.00 RND	4
34	0536	NUT 0.44-14 HHGR5	1
35	C0081	CLAMP 0.50 BLK VINYL	1

Main Boom Assembly (24V Option) - PN 67868

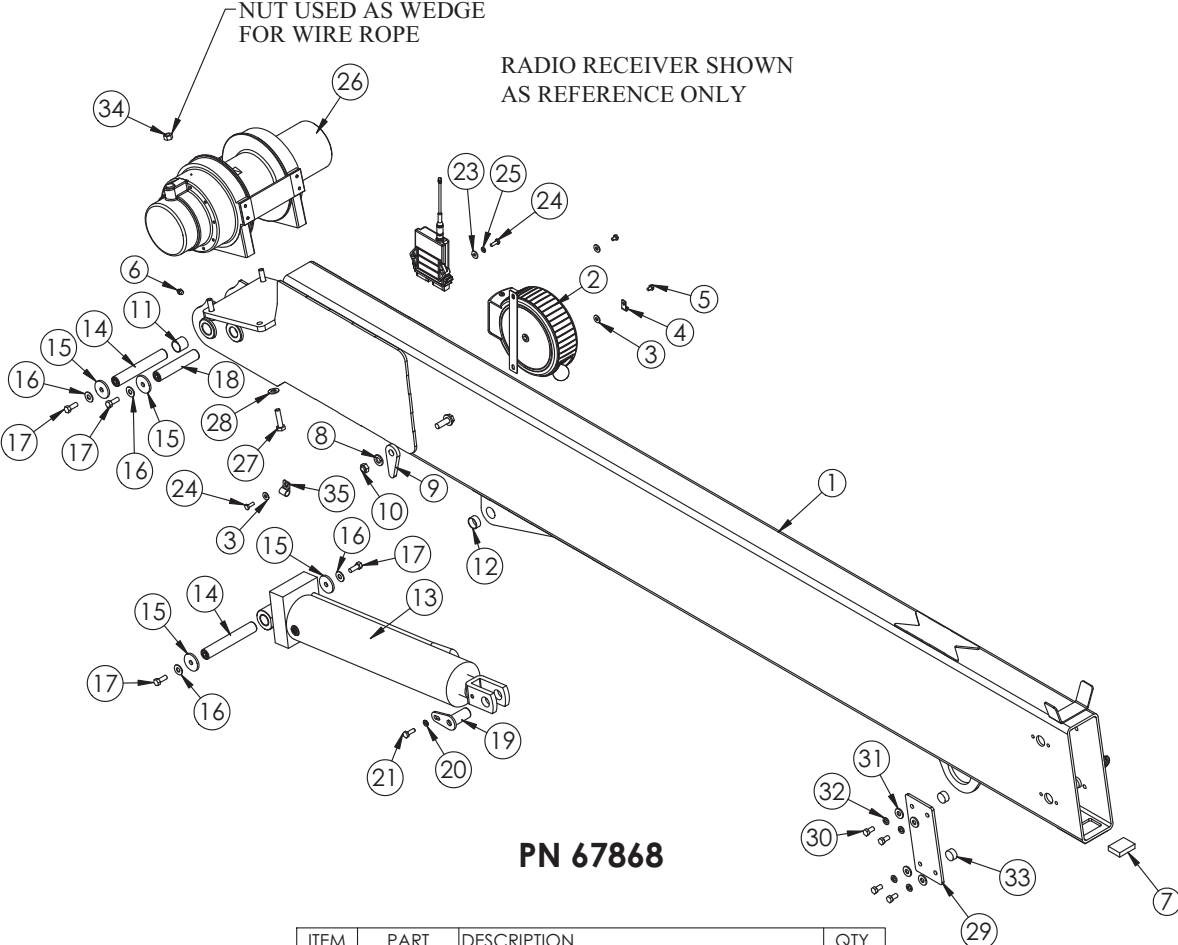

ITEM	PART	DESCRIPTION	QTY.
1	50510	INNER BOOM EC5000	1
2	72602	CORD REEL ASM 21 FT CRANE	1
3	0340	WASHER 0.25 FLAT	3
4	C5606	CLAMP 0.25 BLK VINYL	1
5	43845	CAP SCR 0.25-20X0.38 HHGR5	2
6	c1592	ZERK 1/8 NPT STRAIGHT	1
7	42508	WEAR PAD 0.50X1.50X2.00	1
8	D0790	WASHER 0.50 FLAT GR8	4
9	13815PC	PLATE ANGLE INDICATOR	2
10	C6106	NUT 0.50-13 HHGR5 NYLOC	2
11	0069	BUSHING QSI-1618-16	2
12	20362	BUSHING BPC16DXR08 1.00X.50	1
13	50609	CYLINDER 4.00X13.00	1
14	42515ZP	PIN 1.00X6.38 D&T	2
15	9320	PIN CAP 0.44X1.75X0.19 SS	6
16	C6353	WASHER 0.38 FLAT GR8	6
17	13573	CAP SCR 0.38-16X1.00 HHGR8	6
18	42516ZP	PIN 1.00X5.13 D&T	1
19	42517ZP	PIN TEAR DROP 1.00X2.19	1
20	5591	WASHER 0.31 SAE FLAT YELLOW GR8	1
21	21170	CAP SCR 0.31-18X1.00 HHGR8	1
23	D0917	WASHER 0.25 FLAT SS	2
24	0479	CAP SCR 0.25-20X0.75 HHGR5	3
25	0521	WASHER 0.25 LOCK	2
26	67869	WINCH 2500DC 24V WARN	1
27	50111	CAP SCR 12MMX45MM HHGR8	4
28	42788	WASHER 0.44 SAE FLAT YELLOW GR8	4
29	51168PC	COVER WEAR PAD EC5000	2
30	0492	CAP SCR 0.38-16X0.75 HHGR5	8
31	0346	WASHER 0.38 USS FLAT ZINC	8
32	0523	WASHER 0.38 LOCK	8
33	51169	WEAR PAD 0.50X1.00 RND	4
34	0536	NUT 0.44-14 HHGR5	1
35	C0081	CLAMP 0.50 BLK VINYL	1

Extension Boom Assembly - PN 50611

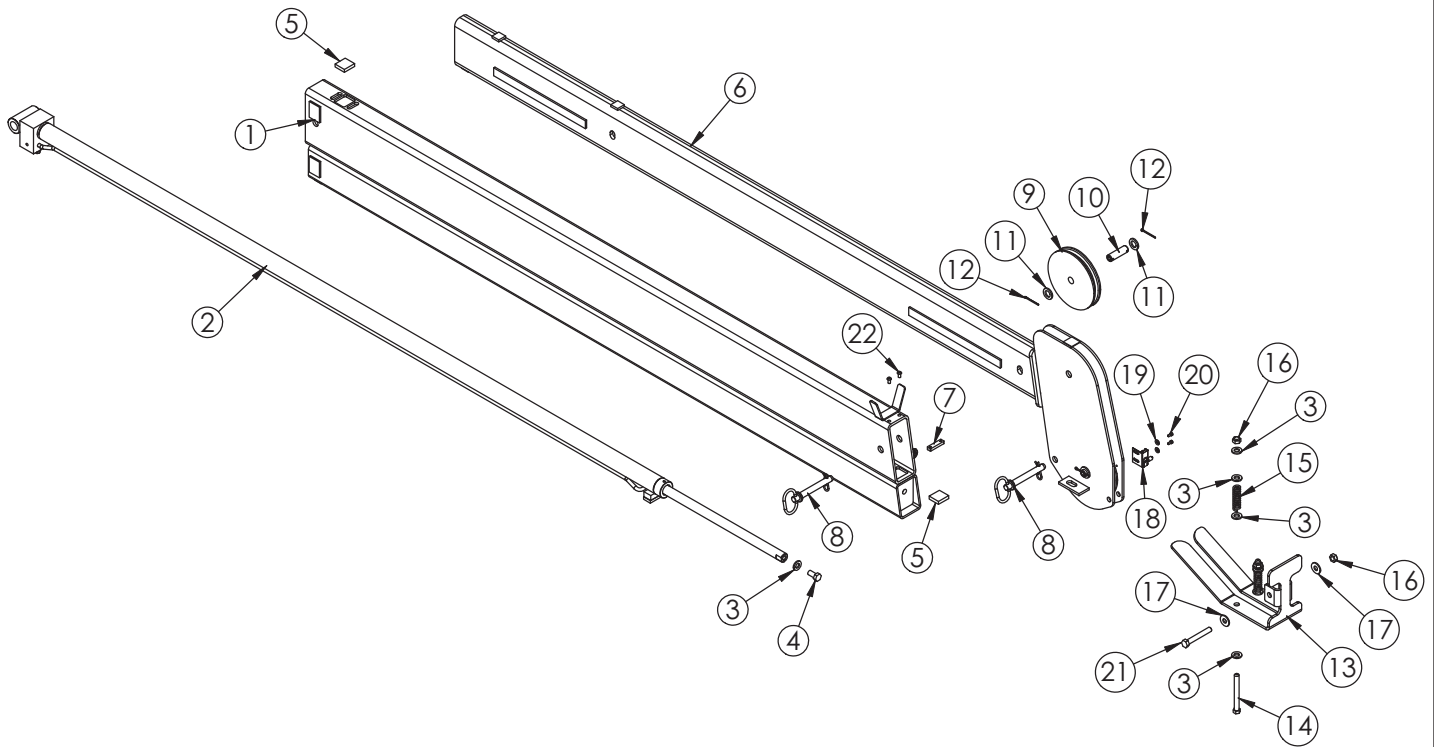

PN 50611

ITEM	PART	DESCRIPTION	QTY.
1	50612	EXT BOOM 1ST EC5000	1
2	50616	CYLINDER 1.50X60.00	1
3	D0790	WASHER 0.50 FLAT GR8	9
4	10172	CAP SCR 0.50-13X1.00 HHGR8 ZY	1
5	42509	WEAR PAD 0.38X1.38X1.50	2
6	50617	EXT BOOM 2ND EC5000	1
7	42978PC	FLAT BOOM STOP EC3200	1
8	42977	PIN HITCH 0.63X4.00	2
9	50387	SHEAVE EC4000 6.75 DIA .31R/1.00THK	2
10	42524ZP	PIN 0.75X2.50 COTTER	2
11	0423	MACHY WASHER 0.75ID 10GA	4
12	37824	COTTER PIN .125X1.00	4
13	50386PC	PLATE CRADLE EC4000	1
14	0507	CAP SCR 0.50-13X4.50 HHGR5	2
15	27710	SPRING ANTI 2 BLOCK SUMMIT	2
16	C6106	NUT 0.50-13 HHGR5 NYLOC	3
17	0352	WASHER 0.50 USS FLAT ZINC	2
18	35105	SWITCH LIMIT E1117-B9111-6C	1
19	D0178	WASHER #10 SAE FLAT ZINC	2
20	43846	SCREW #10-24X0.38 SH SS	2
21	0505	CAP SCR 0.50-13X3.50 HHGR5	1
22	D0561	CAP SCR 0.25-20X0.50 BTNHD SS	2

Cable & Hook Assembly - PN 50492

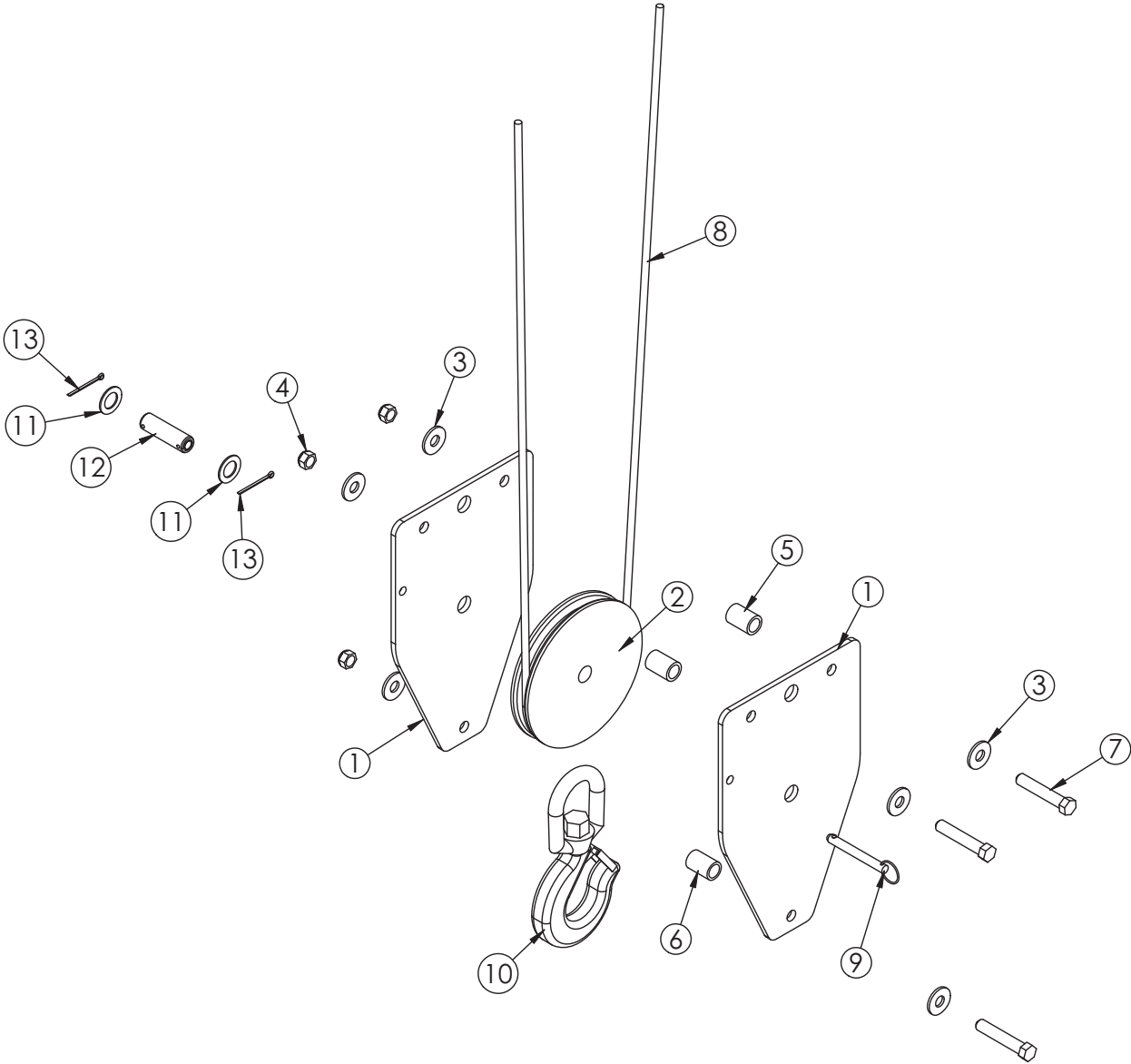

PN 50492

ITEM	PART	DESCRIPTION	QTY.
1	50493PC	PLATE SNATCH BLOCK EC4000	2
2	50387	SHEAVE EC4000 6.75 DIA .31R/1.00THK	1
3	0352	WASHER 0.50 USS FLAT ZINC	6
4	5468	NUT 0.50-13 HHGR8 NYLOC	3
5	27810	SPACER 3315 SNATCH BLOCK UHMW	2
6	16607PC	SPACER 3315 SNATCH BLOCK	1
7	47868	CAP SCR 0.50-13X2.75 HHGR8	3
8	9610	WIRE ROPE 0.31 6X19 IWRC-XIP 90FT	1
9	9263	PIN .38X3.00 QUICK RELEASE	1
10	C6018	HOOK CRANE-3 TON	1
11	0375	MACHY WASHER 0.75ID 14GA	2
12	42524ZP	PIN 0.75X2.50 COTTER	1
13	37824	COTTER PIN .125X1.00	2

Radio Transmitter Assembly

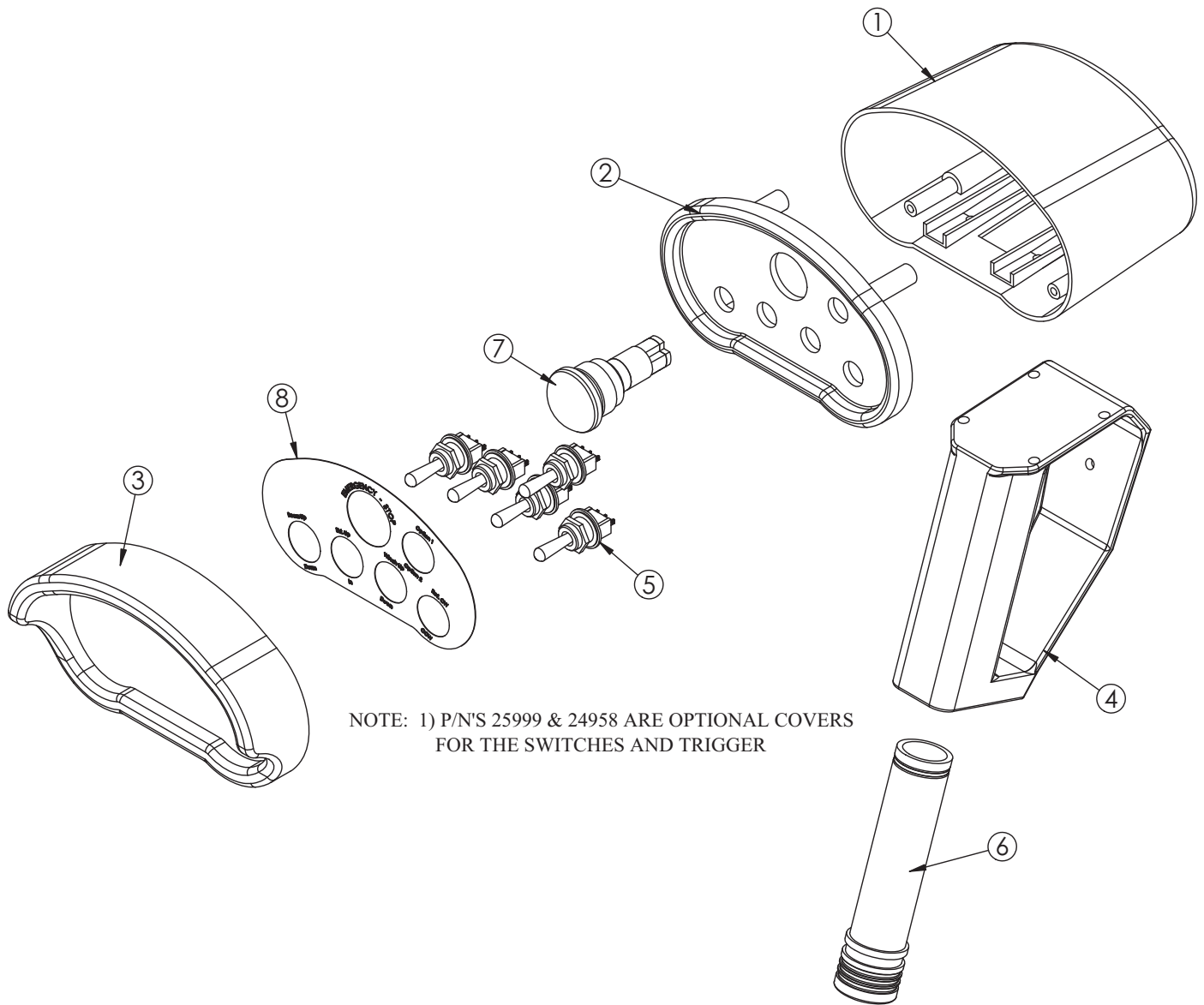

NOTE: 1) P/N'S 25999 & 24958 ARE OPTIONAL COVERS FOR THE SWITCHES AND TRIGGER

ITEM	PART	DESCRIPTION	QTY.
1	20088	CONTROL HANDLE HOUSING 4 FCTN HET	1
2	51830	CONTROL HANDLE FACE PLT 5 FCTN	1
3	24385	GUARD RADIO SWITCH 4 FCTN	1
4	50932	CONTROL HANDLE GRIP LESS TRIGGER HET H2	1
5	22600	SWITCH TOGGLE HET RADIO 63019300	5
6	35441	BATTERY TUBE AA HETRONIC RADIO	1
7	16975	SWITCH E STOP ASM HETRONIC RADIO	1
8	51831	DECAL CONTROL HANDLE 5 FCTN	1

Chapter 4 - Replacement Parts

HYDRAULIC COMPONENTS

PART#	DESCRIPTION
42840	HYDRAULIC SWING MOTOR
21151	GASKET - HYDRAULIC SWING MOTOR
42513	POWER UNIT 12V EC3200
67931	POWER UNIT 24V EC3200-EC5000 (24V Systems only)
44028	VALVE CARTRIDGE - POWER UNIT 12V #19012-D
44027	VALVE COIL - POWER UNIT 12V #11494-D
44029	MOTOR 12V - POWER UNIT #08111-1
44030	12V SOLENOID (12volt hydraulic system) #17757
44026	HYDRAULIC RESERVOIR - POWER UNIT 12V #14071
44025	FILL CAP - HYDRAULIC RESERVOIR
9803	C-BALANCE VALVE
51840	SEAL KIT - MAIN LIFT CYLINDER
43893	SEAL KIT - EXTENSION CYLINDER
49315	PRESSURE SWITCH
C2027	O'RING - # 4 FACE SEAL
C2028	O'RING - # 6 FACE SEAL
D1245	O'RING - # 4 SAE
D1246	O'RING - # 6 SAE

ASSEMBLY COMPONENTS

52256	WORM GEAR - ROTATION BEARING
27184	BEARING & SEAL KIT - ROTATION BEARING
35225	BEARING RETAINER - ROTATION BEARING
20362	BUSHING 1.00" X 0.50"
0069	BUSHING 1.00" X 1.00"
42508	WEAR PAD 0.38" X 1.50" X 2.00"
42509	WEAR PAD 0.38" X 1.38" X 1.50"
42978	BOOM STOP FLAT
9320	PIN CAP 0.44" X 1.75" X 0.25" SS
C6353	WASHER 0.38 FLAT GR8
13573	CAP SCR. 0.38-16 X 1.00" GR8
0375	MACHINE WASHER -0.75" ID 14GA.
0423	MACHINE WASHER -0.75" ID 10GA.
50387	SHEAVE
9610	WIRE ROPE
42977	HITCH PIN 0.63" X 4.00"
9263	QUICK RELEASE PIN .38 X 3.00"
50386PC	CRADLE PLATE
27710	SPRING ANTI-2-BLOCK
C6018	HOOK 3-TON
10709	SAFETY LATCH FOR 3 TON HOOK - Campbell
51330	SAFETY LATCH FOR 3 TON HOOK - Crosby
C1592	GREASE ZERK

ELECTRICAL COMPONENTS

35105	LIMIT SWITCH
11544	CORD REEL
47410	MOMENTARY SWITCH
17771	PUSH BUTTON (12volt hydraulic system)
50226	WINCH 12V
67869	WINCH 24V (24V Systems only)
36436	FUSE 250 AMP
28978	BOSCH RELAY
42821	CONTROLLER SOLENOID 12V
67867	CONTROLLER SOLENOID 24V (24V Systems only)
36176	CABLE ASM #4 16IN BLACK (24V Systems only)
58298	RELAY BOSCH 24V STANDARD (24V Systems only)

RADIO REMOTE COMPONENTS

39784	RADIO REMOTE SYSTEM
50932	HANDLE ASM
16975	E-STOP SWITCH
22600	TOGGLE SWITCH
20088	LOWER TRANSMITTER HOUSING
35441	BATTERY TUBE HOLDER
35916	BACK UP CORD



Limited Warranty Statement

Stellar Industries, Inc. (Stellar) warrants products designed and manufactured by Stellar to be free from defects in material and workmanship under proper use and maintenance. Products must be installed and operated in accordance with Stellar's written instructions and capacities. This warranty shall cover the following:

Stellar Cranes, Stellar Hooklift Hoists, Stellar Cable Hoists, Stellar Container Carriers, Stellar Service Trucks, and Stellar X-Tra-Lift Systems:

Twelve (12) month warranty on parts from the date recorded by Stellar as the in-service date, not to extend beyond twenty-four (24) months from date of manufacture.

Twelve (12) month repair labor from the date recorded by Stellar as the in-service date, not to extend beyond twenty-four (24) month from date of manufacture, and

Thirty-six (36) month warranty on all Stellar Manufactured structural parts from the date recorded by Stellar as the in-service date, not to extend beyond forty-eight (48) months from date of manufacture.

Stellar Tarper Systems:

Twelve (12) month warranty on parts from the date recorded by Stellar as the in-service date, not to extend beyond twenty-four (24) months from date of manufacture and

Three (3) month repair labor from the date recorded by Stellar as the in-service date, not to extend beyond fifteen (15) month from date of manufacture.

The in-service date will be derived from the completed warranty registration card. In the event a warranty registration card is not received by Stellar, the factory ship date will be used.

Stellar's obligation under this warranty is limited to, and the sole remedy for any such defect shall be, the repair and/or replacement (at Stellar's option) of the unaltered part and/or component in question. Stellar after-sales service personnel must be notified by telephone, fax, or letter of any warranty-applicable damage within fourteen (14) days of its occurrence. If at all possible, Stellar will ship the replacement part within 24-hours of notification by the most economical, yet expedient, means possible. Expedited freight delivery will be at the expense of the owner.

Warranty claims must be submitted and shall be processed in accordance with Stellar's established warranty claim procedure. Stellar after-sales service personnel must be contacted prior to any warranty claim. A return materials authorization (RMA) account number must be issued to the claiming party prior to the return of any warranty parts. Parts returned without prior authorization will not be recognized for warranty consideration. All damaged parts must be returned to Stellar freight prepaid; freight collect returns will be refused. Freight reimbursement of returned parts will be considered as part of the warranty claim.

Warranty service will be performed by any Stellar new equipment distributor, or by any Stellar-recognized service center authorized to service the type of product involved, or by the Stellar factory in the event of a direct sale. At the time of requesting warranty service, the owner must present evidence of date of delivery of the product. The owner shall be obligated to pay for any overtime labor requested of the servicing company by the owner, any field service call charges, and any towing and/or transportation charges associated with moving the equipment to the designated repair/service provider.

All obligations of Stellar and its authorized dealers and service providers shall be voided if someone other than an authorized Stellar dealer provides other than routine maintenance service without prior written approval from Stellar. In the case repair work is performed on a Stellar-manufactured product, original Stellar parts must be used to keep the warranty in force. The warranty may also be voided if the product is modified or altered in any way not approved, in writing, by Stellar.

The owner/operator is responsible for furnishing proof of the date of original purchase of the Stellar product in question. Warranty registration is the ultimate responsibility of the owner and may be accomplished by the completion and return of the Stellar product registration card provided with the product. If the owner is not sure of registration, he is encouraged to contact Stellar at the address below to confirm registration of the product in question. This warranty covers only defective material and workmanship. It does not cover depreciation or damage caused by normal wear and tear, accident, mishap, untrained operators, or improper or unintended use. The owner has the obligation of performing routine care and maintenance duties as stated in Stellar's written instructions, recommendations, and specifications. Any damage resulting from owner/operator failure to perform such duties shall void the coverage of this warranty. The owner will pay the cost of labor and supplies associated with routine maintenance.

The only remedies the owner has in connection with the breach or performance of any warranty on the Stellar product specified are those set above. In no event will Stellar, the Stellar distributor/dealer, or any company affiliated with Stellar be liable for business interruptions, costs of delay, or for any special, indirect, incidental, or consequential costs or damages. Such costs may include, but are not limited to, loss of time, loss of revenue, loss of use, wages, salaries, commissions, lodging, meals, towing, hydraulic fluid, or any other incidental cost.

All products purchased by Stellar from outside vendors shall be covered by the warranty offered by that respective manufacturer only. Stellar does not participate in, or obligate itself to, any such warranty.

Stellar reserves the right to make changes in design or improvement upon its products without imposing upon itself the same upon its products theretofore manufactured.

This warranty will apply to all Stellar Cranes, Stellar Hooklift Hoists, Stellar Cable Hoists, Stellar Container Carriers, Stellar Service Trucks, Stellar X-Tra-Lift Systems, and Stellar Tarper Systems shipped from Stellar's factory after January 1st, 2010. The warranty is for the use of the original owner only and is not transferable without prior written permission from Stellar.

THIS WARRANTY IS EXPRESSLY IN LIEU OF ANY OTHER WARRANTIES, EXPRESS OR IMPLIED, INCLUDING ANY WARRANTY OF MERCHANTABILITY OR FITNESS FOR A PARTICULAR PURPOSE. REMEDIES UNDER THIS WARRANTY ARE LIMITED TO THE PROVISION OF MATERIAL AND SERVICES, AS SPECIFIED HEREIN. STELLAR INDUSTRIES, INC. IS NOT RESPONSIBLE FOR INCIDENTAL OR CONSEQUENTIAL DAMAGES.

Revision Date: February 2010

Document Number: 37040