



# MODEL EC3200

## TELESCOPIC CRANE

### OWNERS' MANUAL

Installation • Assembly Drawings • Parts

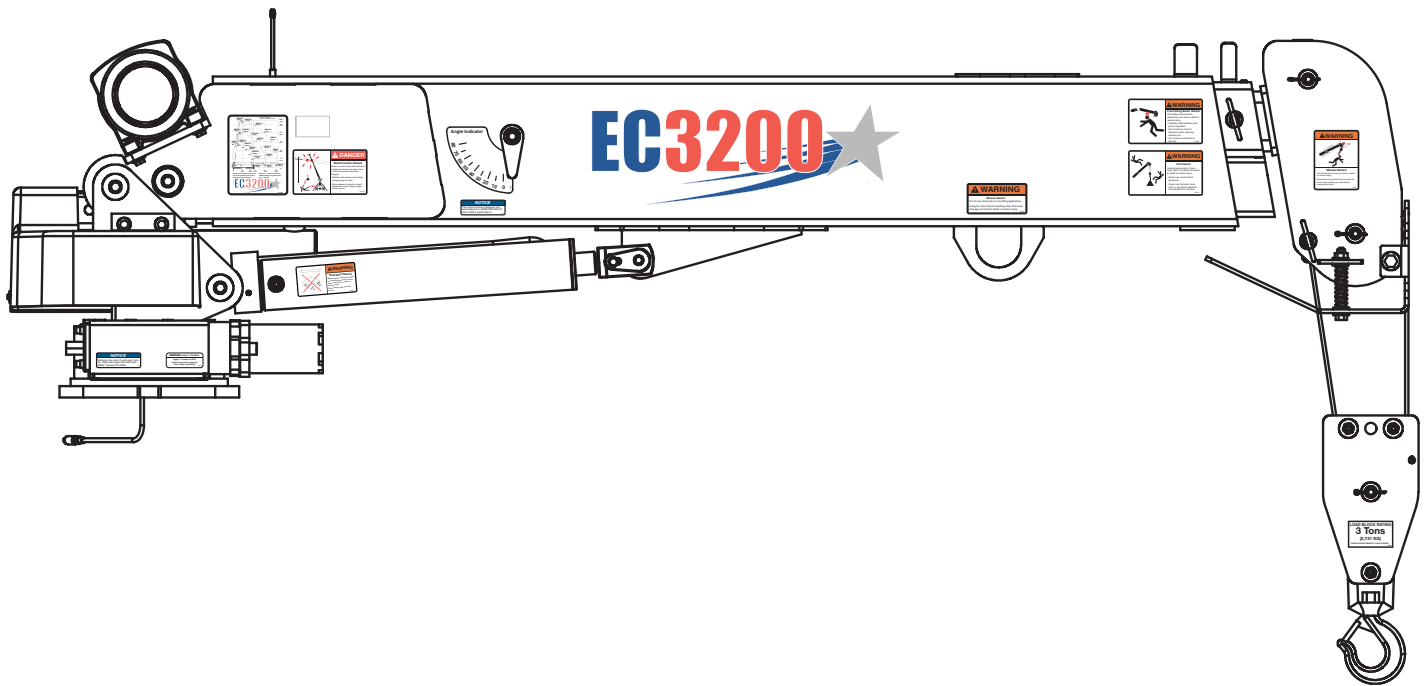

Notice: A copy of this manual must remain with the equipment at all times.  
For a printable download copy, please visit: [www.stellarindustries.com](http://www.stellarindustries.com)

**Stellar Industries, Inc.**

190 State Street

PO Box 169

Garner, IA 50438

800-321-3741

Fax: 641-923-2811

[www.stellarindustries.com](http://www.stellarindustries.com)

Subject to Change without Notification.  
© 2018 Stellar Industries, Inc.

Rev 1  
PN 44024

# EC3200 Manual Revisions

Date of Revision	Sections Revised	Description of Revision

**Serial Tag  
Location**

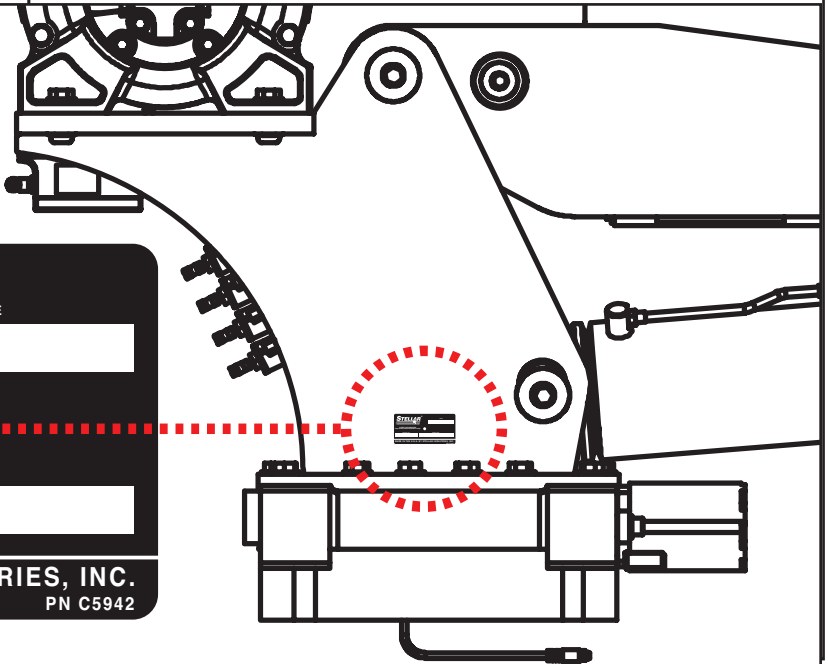

**STELLAR**<sup>®</sup>

DATE

PATENT INFORMATION  
<http://www.stellarindustries.com/ip>

MODEL NO.  SERIAL NO.

**MADE IN THE U.S.A. BY STELLAR INDUSTRIES, INC.**  
PN C5942

# Table of Contents

---

Introduction.....	ii
<b>Chapter 1 - Specifications.....</b>	<b>1</b>
Capacity Chart - Decal PN 42817.....	2
<b>Chapter 2 - Installation .....</b>	<b>3</b>
General Installation.....	3
Installer Notice.....	3
Torque Data Chart.....	4
Installation Overview.....	5
EC3200 Mounting Detail.....	6
Flatbed Body Reinforcement.....	6
EC3200 Installation Drawing.....	7
Hydraulic Kit - PN 42799 .....	8
Valve Bank Drawing.....	9
Control Kit - PN 42804.....	10
EC3200 Wiring Diagram (Two Battery) .....	11
EC3200 Wiring Diagram (One Battery) .....	12
Electrical Circuit Grounding.....	13
Stability Procedure .....	14
Decal Kit Placement - PN 42816 .....	15
<b>Chapter 3 - Assembly Drawings .....</b>	<b>17</b>
Base Assembly - PN 42525 .....	17
Base Assembly (Narrow Version) - PN 44613 .....	18
Mast Assembly - PN 42787 .....	19
Power Unit Assembly - PN 42513 .....	20
Main Boom Assembly - PN 42512.....	21
Extension Boom Assembly - PN 42520 .....	22
Cable & Hook Assembly - PN 42781 .....	23
Gear Bearing Assembly - PN 41640 .....	24
Radio Transmitter Assembly - PN 67894.....	25
<b>Chapter 4 - Replacement Parts .....</b>	<b>27</b>

# Introduction

A copy of this manual is provided with every crane and can be found in the hard plastic manual case that is installed on the chassis. A copy of this manual shall remain with the crane at all times.

Throughout the manual, three signal words will be used to bring attention to important items:

## **NOTICE**

A NOTICE signal word indicates a practice not related to physical injury.

## **⚠ WARNING**

A WARNING signal word indicates a hazardous situation which, if not avoided, could result in death or serious injury.

## **⚠ DANGER**

A DANGER signal word indicates a hazardous situation which, if not avoided, will result in death or serious injury.

Information contained within this manual does not cover operation, maintenance, or troubleshooting. Please refer to the General EC Crane Manual for details on these items.

This manual is not binding. Stellar Industries, Inc. reserves the right to change, at any time, any or all of the items, components, and parts deemed necessary for product improvement or commercial/production purposes. This right is kept with no requirement or obligation for immediate mandatory updating of this manual.

In closing:

If more information is required or technical assistance is needed, or if you feel that any part of this manual is unclear or incorrect, please contact the Stellar Customer Service Department by phone at 800-321-3741 or email at [service@stellarindustries.com](mailto:service@stellarindustries.com).

**For Technical Questions, Information, Parts, or Warranty, Call Toll-Free at  
800-321-3741**

Hours: Monday - Friday, 8:00 a.m. - 5:00 p.m. CST

Or email at the following addresses:

**Technical Questions, and Information**

[service@stellarindustries.com](mailto:service@stellarindustries.com)

**Order Parts**

[parts@stellarindustries.com](mailto:parts@stellarindustries.com)

**Warranty Information**

[warranty@stellarindustries.com](mailto:warranty@stellarindustries.com)

# Chapter 1 - Specifications

## Model EC3200 Crane SPECIFICATION SHEET

Crane Rating:	11,500 ft-lb (1.59 TM)
Standard Boom Length:	7' (2.13 m) from CL of Crane
Boom Extension:	1st stage: Hydraulic 48" (121.9 cm) 2nd stage: Manual 48" (121.9 cm)
Maximum Horizontal Reach:	15' (4.57 m) from CL of Crane
Maximum Vertical Lift: (from crane base)	16' 2" (4.93 m)
Boom Elevation:	-5 to +80 degrees
Stowed Height: (crane only)	24" (61.0 cm)
Mounting Space Required:	18" x 15" (45.7 x 38.1 cm)
Approximate Crane Weight:	730 lbs (331 kg)
Controls:	Radio control standard for all functions.
Winch Specifications	
Rope Length:	65 ft (19.8 m)
Rope Diameter:	7/32" (.56 cm)
Line pull speed:	15 ft/min (4.6 m/min)
Max. single part line:	1600 lbs (725 kg)
Max. double part line:	3200 lbs (1450 kg)
Rotation: (worm gear)	410 degree power
Lifting Capacities:	1625 lbs @ 7' (737 kg @ 2.1 m) 905 lbs @ 11' (410 kg @ 3.35 m) 640 lbs @ 15' (290 kg @ 4.6 m)
Power Supply Required:	12 volt power unit (2.0 gpm @ 2600 psi) (7.57 lpm @ 179 bar)

\*Subject to change without notification

# Capacity Chart - Decal PN 42817

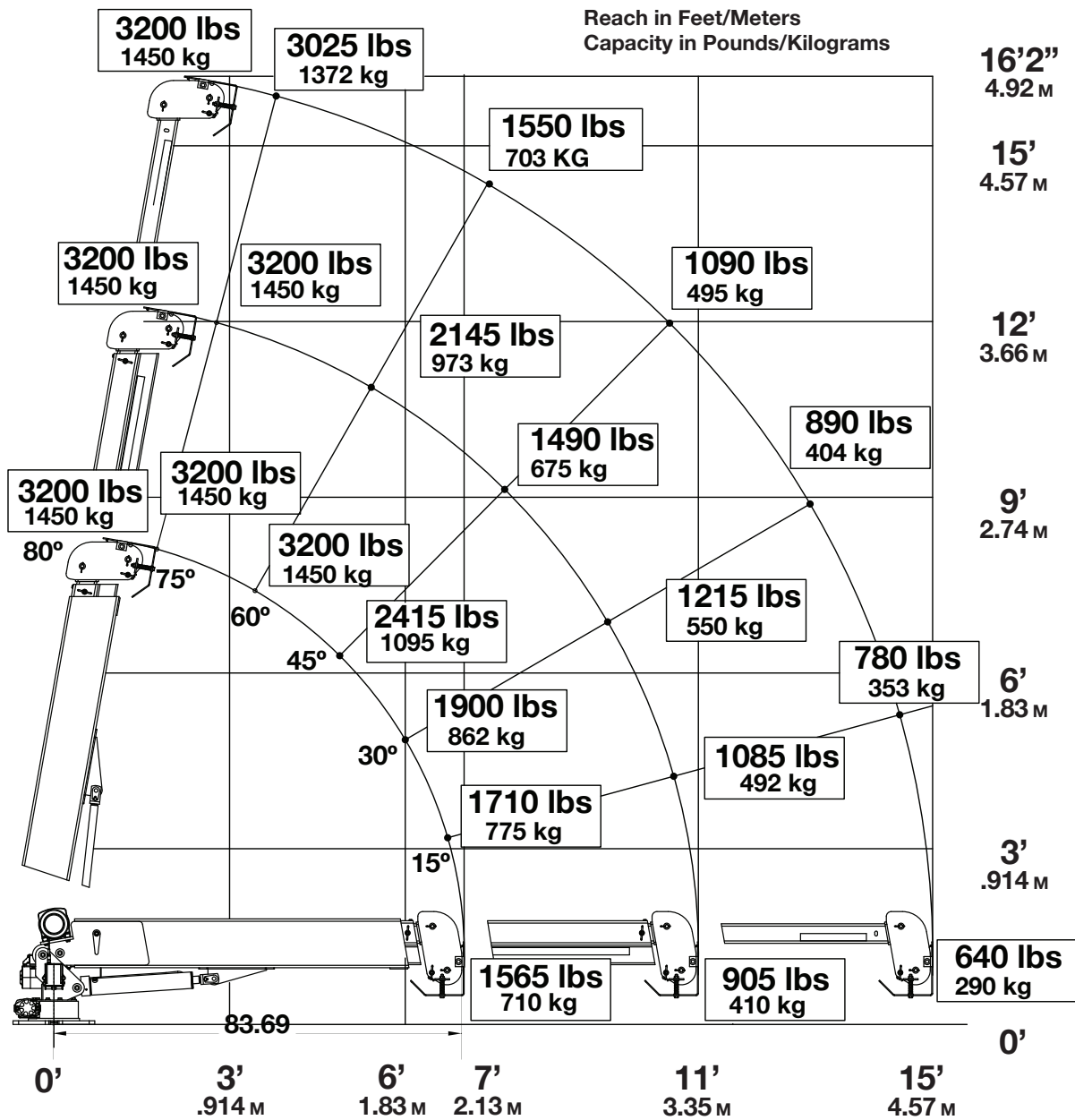

Weight of load handling devices are part of the load lifted and must be deducted from the capacity.

Maximum 1 - part line capacity is 1600lbs (725kg). For greater loads, use 2 - part line.

# EC3200

PN 42817

# Chapter 2 - Installation

## General Installation

This chapter is designed to serve as a general guide for the installation of a EC3200 Crane. Each installation is considered unique so certain portions of this chapter may or may not apply to your direct application. If a question should arise during the installation process, please contact Stellar Customer Service at (800) 321 3741.

It is the installer's responsibility to assure that the crane is mounted on a platform that will support the maximum crane rating of this crane.

**⚠ WARNING** Do not install this crane on a body not capable of handling the loads imposed on it. Failure to do so may result in serious injury or death.

**NOTICE** When installing welder units to the service bodies, it is highly recommended that a surge protector is installed on the chassis batteries to protect the crane radio receiver, wiring and other electronic devices from an unexpected electrical spike or surge. Failure to do so could result in extensive damage to the service body and crane electrical circuit.

## Installer Notice

According to Federal Law (49 cfr part 571), each final-stage manufacturer shall complete the vehicle in such a manner that it conforms to the standards in effect on the date of manufacture of the incomplete vehicle, the date of final completion, or a date between those two dates. This requirement shall, however, be superseded by any conflicting provisions of a standard that applies by its terms to vehicles manufactured in two or more stages.

Therefore, the installer of Stellar® Cranes and Bodies is considered one of the manufacturers of the vehicle. As such a manufacturer, the installer is responsible for compliance with all applicable federal and state regulations. They are required to certify that the vehicle is in compliance with the Federal Motor Vehicle Safety Standards and other regulations issued under the National Traffic and Motor Vehicle Safety Act.

Please reference the Code of Federal Regulations, title 49 - Transportation, Volume 5 (400-999), for further information, or visit <http://www.gpoaccess.gov/nara/index.html> for the full text of Code of Federal Regulations.

## Torque Data Chart

When using the torque data in the chart, the following rules should be observed:

- Bolt manufacturer's particular specifications should be consulted when provided.
- Flat washers of equal strength must be used.
- All torque measurements are given in foot-pounds. To convert to inch-pounds, multiply by 12.
- Torque values specified are for bolts with residual oils or no special lubricants applied. If special lubricants of high stress ability, such as Never-Seez compound graphite and oil, molybdenum disulphite, colloidal copper or white lead are applied, multiply the torque values in the charts by the factor .90. The use of Loctite does not affect the torque values listed above.
- Torque values for socket-head capscrews are the same as for Grade 8 capscrews.
- Do not use these values if a different torque value or tightening procedure is given for a specific application. Torque values listed are for general use only. Check tightness of fasteners periodically.
- Shear bolts are designed to fail under predetermined loads. Always replace shear bolts with identical grade.
- Fasteners should be replaced with the same or higher grade. If higher grade fasteners are used, these should only be tightened to the strength of the original.
- Tighten plastic insert or crimped steel-type lock nuts to approximately 110 percent of the dry torque values shown in the chart below, applied to the nut, not to the bolt head. Tighten toothed or serrated-type lock nuts to the full torque value. *Note: "Lubricated" means coated with a lubricant such as engine oil, or fasteners with phosphate and oil coatings. "Dry" means plain or zinc plated without lubrication. Tighten lubricated bolts to approximately 80% of dry bolts.*

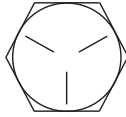
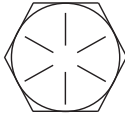
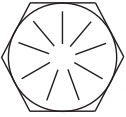
		GRADE 5		GRADE 8		GRADE 9
						
Size (DIA-TPI)	Bolt DIA (Inches)	Plain (Ft-Lb)	Plated (Ft-Lb)	Plain (Ft-Lb)	Plated (Ft-Lb)	Plated (Ft-Lb)
5/16-18	0.3125	17	13	25	18	22
3/8-16	0.3750	31	23	44	33	39
7/16-14	0.4375	49	37	70	52	63
1/2-13	0.5000	75	57	105	80	96
9/16-12	0.5625	110	82	155	115	139
5/8-11	0.6250	150	115	220	160	192
3/4-10	0.7500	265	200	375	280	340
7/8-9	0.8750	395	295	605	455	549
1-8	1.000	590	445	910	680	823
1 1/8-7	1.1250	795	595	1290	965	1167
1 1/4-7	1.2500	1120	840	1815	1360	1646
1 3/8-6	1.3750	1470	1100	2380	1780	2158
1 1/2-6	1.500	1950	1460	3160	2370	2865



# Installation Overview

1. Determine that the mounting location for the EC3200 crane is at least 18" x 15" (45.7 x 38.1 cm).
2. Use the detail on the following page to drill .938" diameter holes into the mounting plate. Run tap on the threads of the base to be sure they are clean.
3. Use a crane or lifting device capable of lifting the weight of the Stellar crane. The Stellar EC3200 weighs approximately 800 lbs (360 kg). **Note: cranes are shipped with rotation positioned at 180 degrees from normal stowed travel position.** This will allow for easy installation of the crane and permanent connection of all hydraulic and electrical components prior to repositioning into the crane saddle.
4. Connect straps or chain from the lifting device to the main boom of the Stellar EC3200.
5. Use four (4) 7/8" x 2" Grade 9 bolts and four (4) 7/8" Grade 9 flat washers.
6. Install a washer on each bolt.
7. Apply Loctite Thread locker #277 to the bolts.
8. Using the lifting device, lower the Stellar EC3200 just above the crane compartment and start the bolts. Have someone assist in leveling the crane.
9. Secure the crane using the mounting hardware provided. **Note: longer or shorter bolts may be required – recommended thread engagement into crane base is 0.75" – use grade 9, zinc plated bolts only.**
10. Torque the bolts to 549 ft-lbs.
11. Remove supporting crane.
12. Hook-up hydraulics and electrical using the schematics provided at the end of this chapter.

**Note: If questions should arise during any portion of this installation, please contact Stellar Customer Service at (800) 321-3741.**

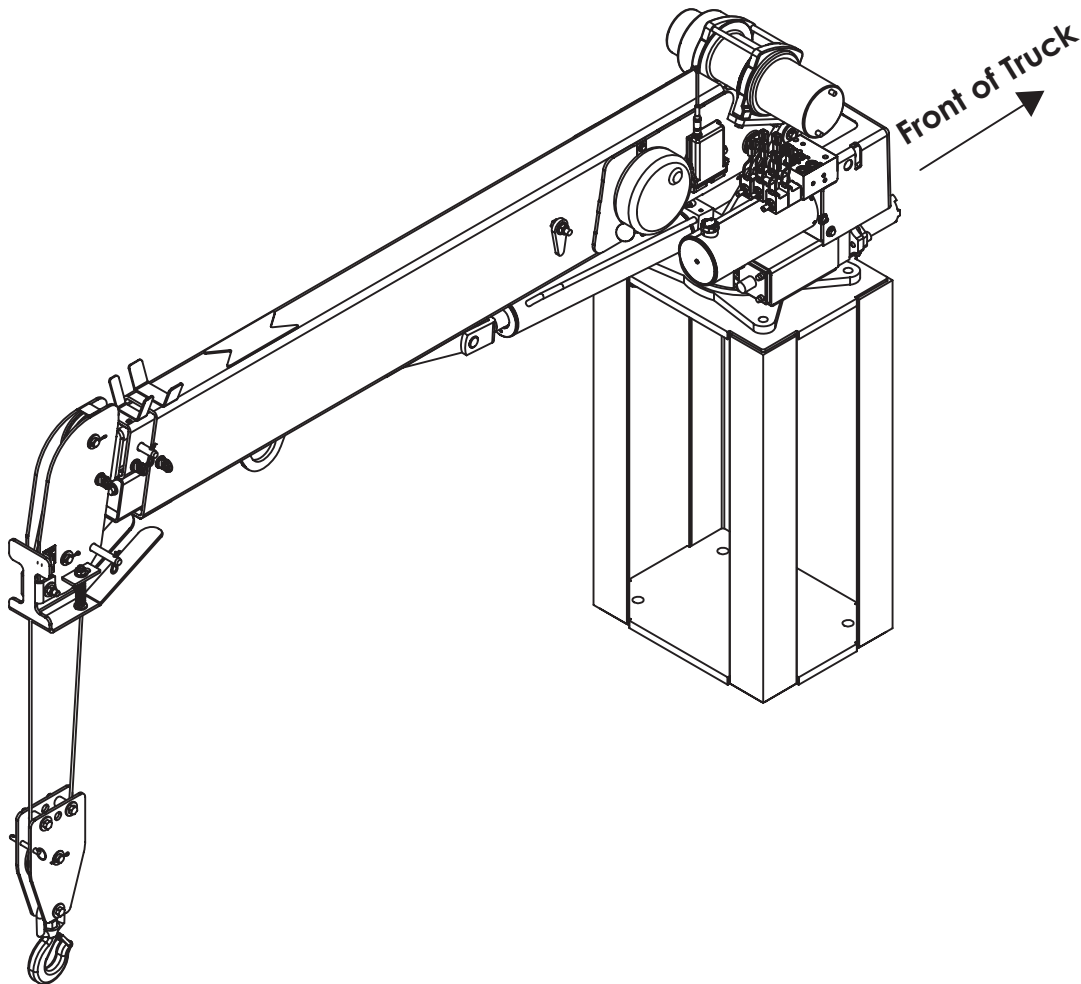

# EC3200 Mounting Detail

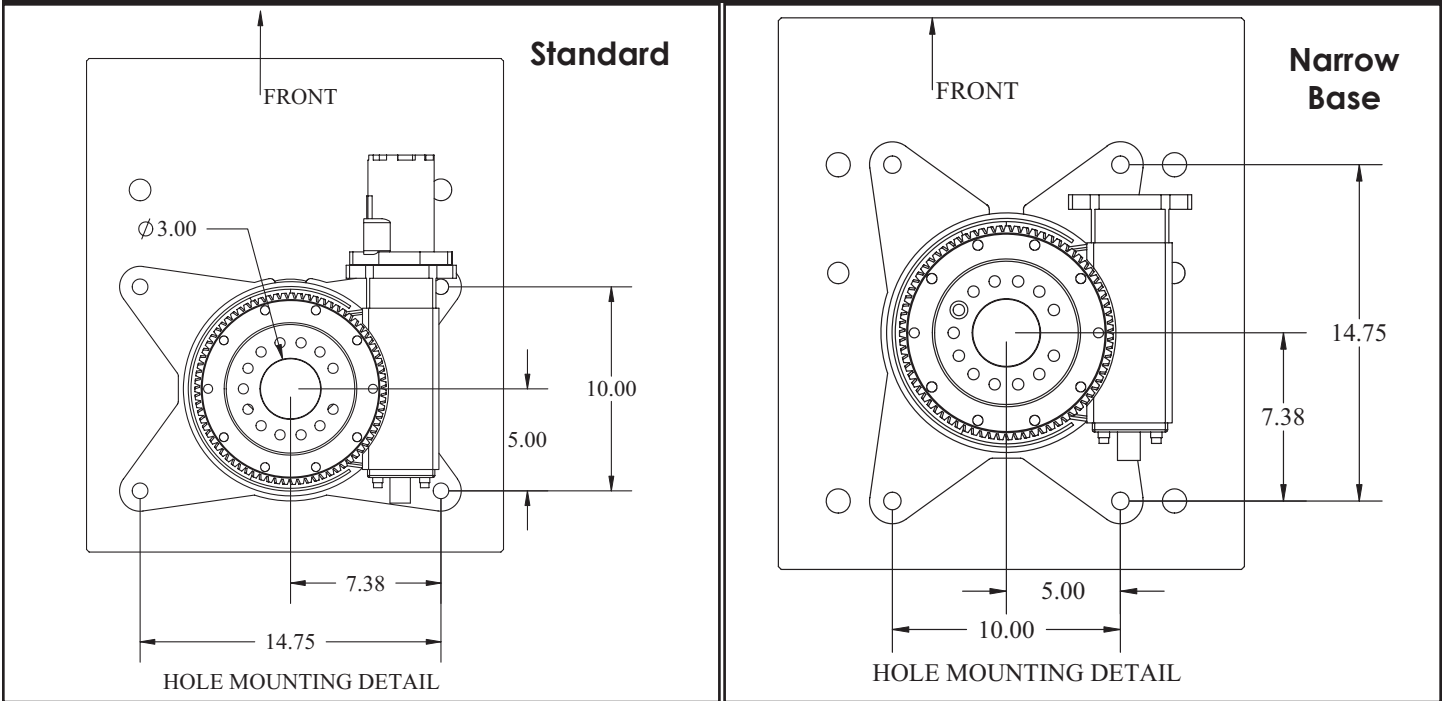

# Flatbed Body Reinforcement

If it has been determined that the destination body won't support the crane with a fully rated load, the body must be reinforced. Use 1/4" fillet welds and an AWS qualified welder to proceed as shown in this drawing:

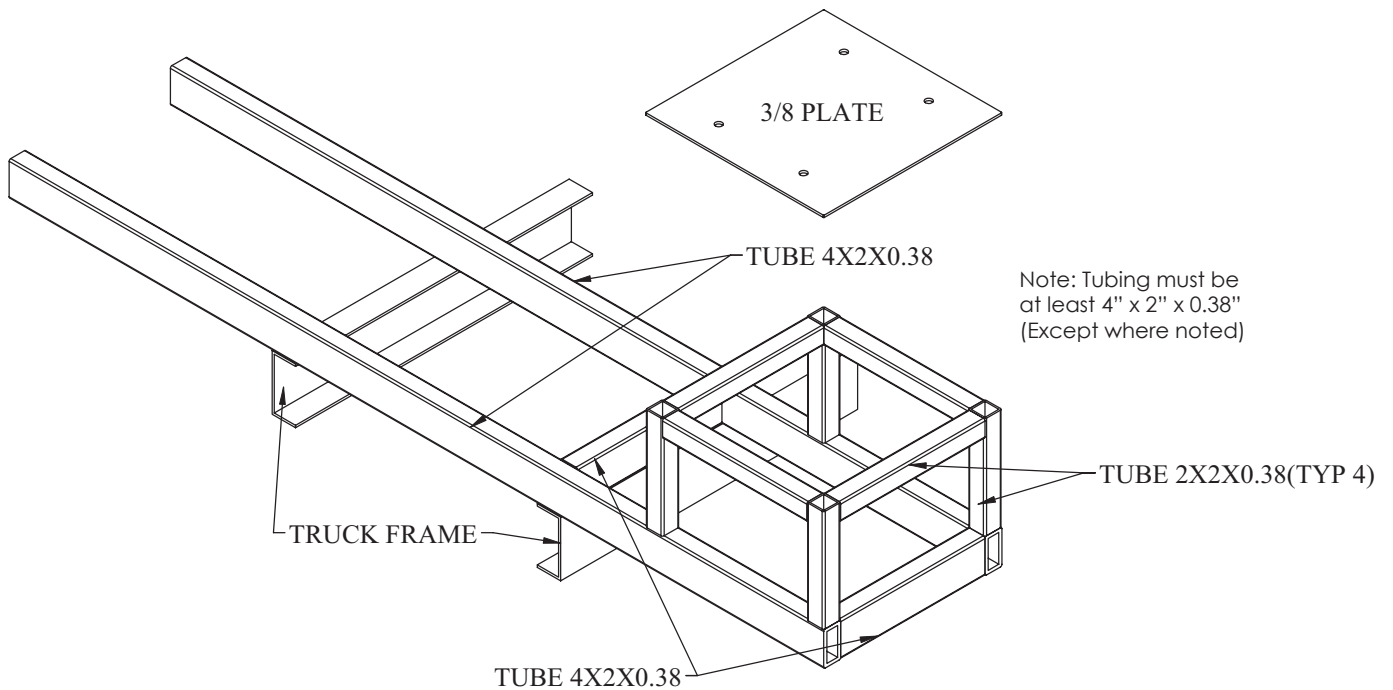

# EC3200 Installation Drawing

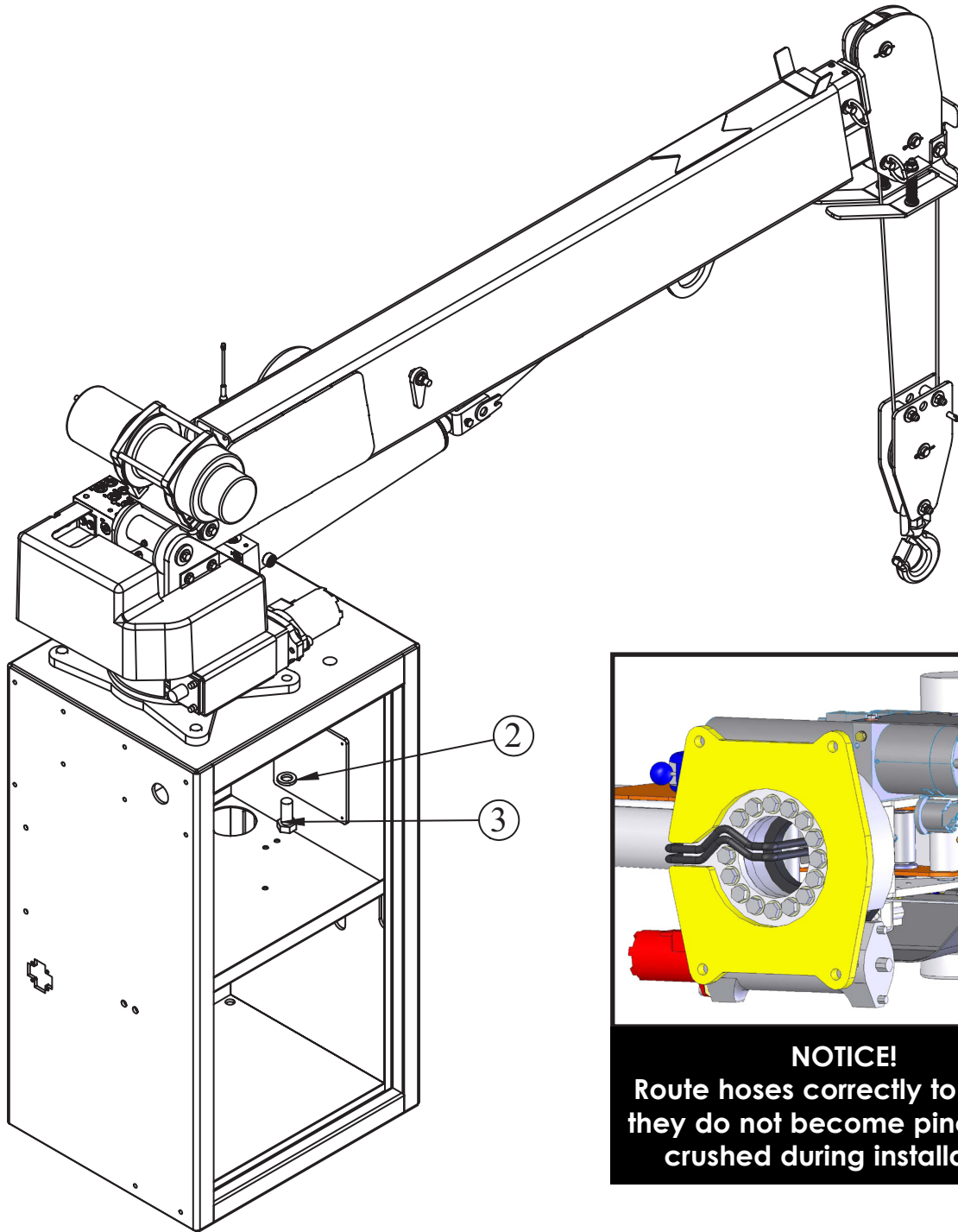

## Stowed Position

ITEM	PART	DESCRIPTION	QTY.
2	18041	WASHER 0.88 SAE FLAT YELLOW GR9	4
3	51377	CAP SCR 0.88-9X2.00 HHGR9	4

**NOTE:**  
STABILITY DECAL P/N 16881 IS PART OF THIS KIT

# Hydraulic Kit - PN 42799

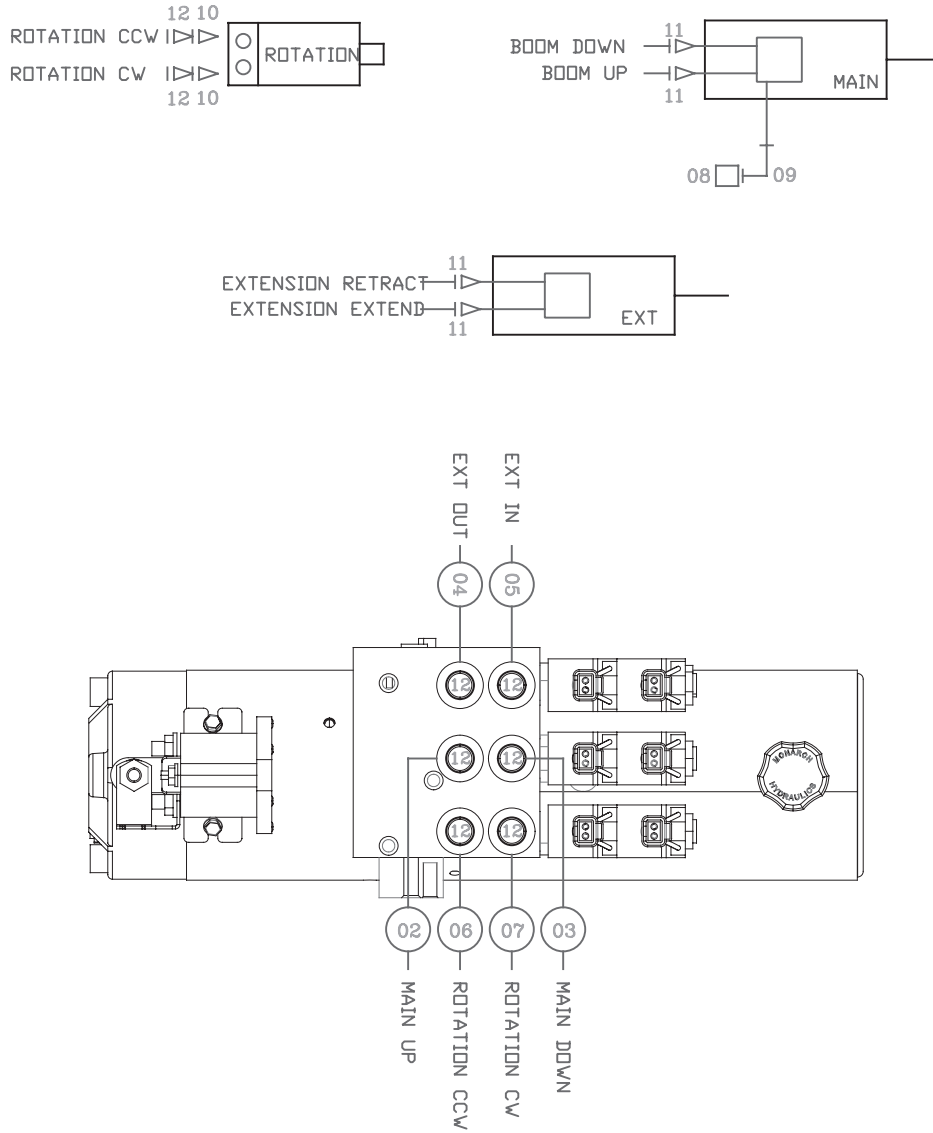

## PN 42799

12	C4922	FTG 4-6 MFS-MORB STRAIGHT	8
11	D1291	FTG 4-4 MFS-MORB STRAIGHT	4
10	C1111	FTG 10-6 MORB-FORB STRAIGHT REDUCER	2
09	3861	FTG 6-6 MADRB-FORB 90	1
08	49315	SWITCH PRES OVERLD CD-11C-2900R/WD	1
07	42984	HOSE-HYD .25X 43	1ref
06	42982	HOSE-HYD .25 X 42	1ref
05	43847	HOSE-HYD .25 X 20	1ref
04	42981	HOSE-HYD .25 X 19	1ref
03	42983	HOSE-HYD .25 X 23	1ref
02	42980	HOSE-HYD .25 X 22	1ref
01	42800	HOSE KIT 3315 CRANE (incl:2-7)	1
ITEM	PART No.	DESCRIPTION	QTY

# Valve Bank Drawing

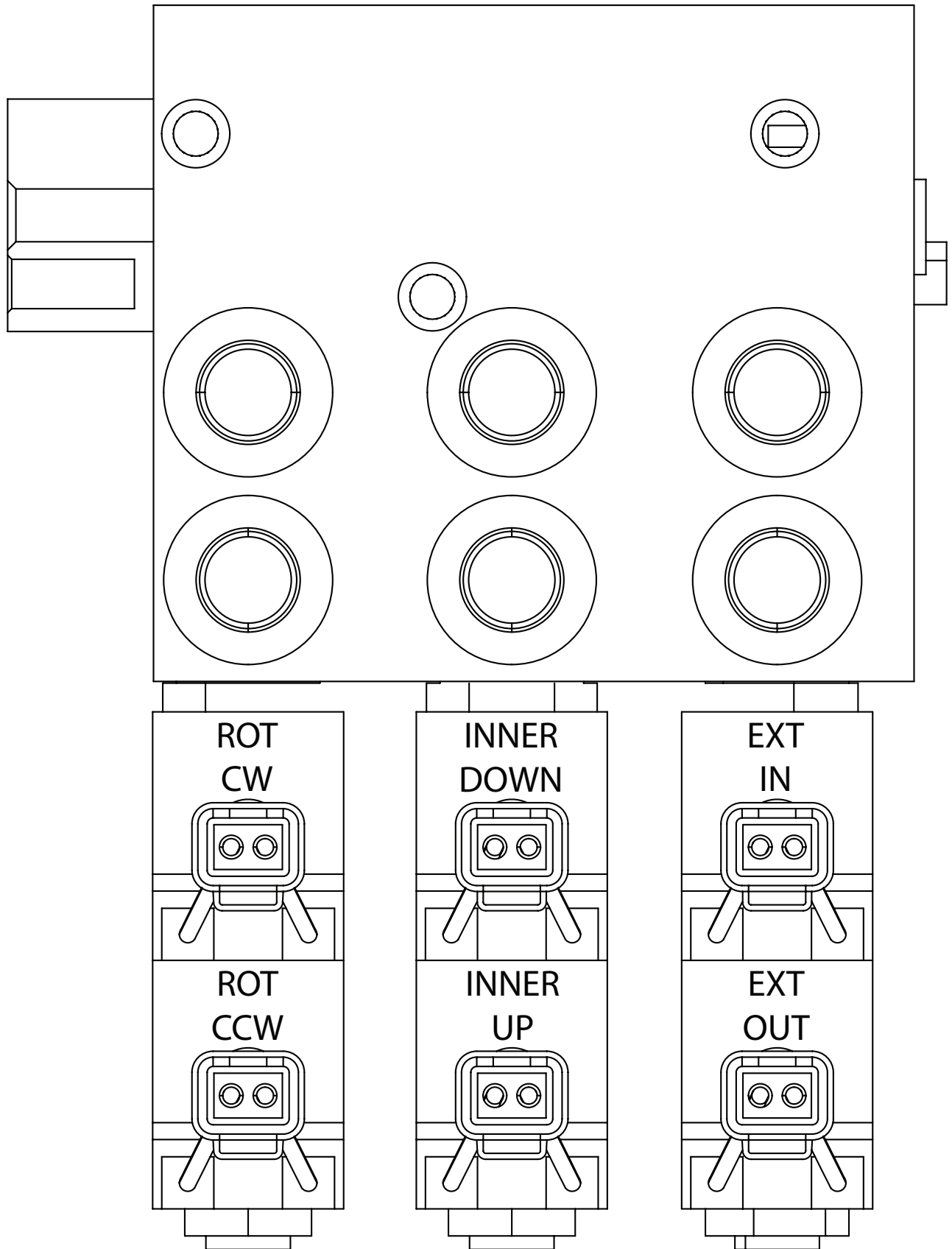

# Control Kit - PN 42804

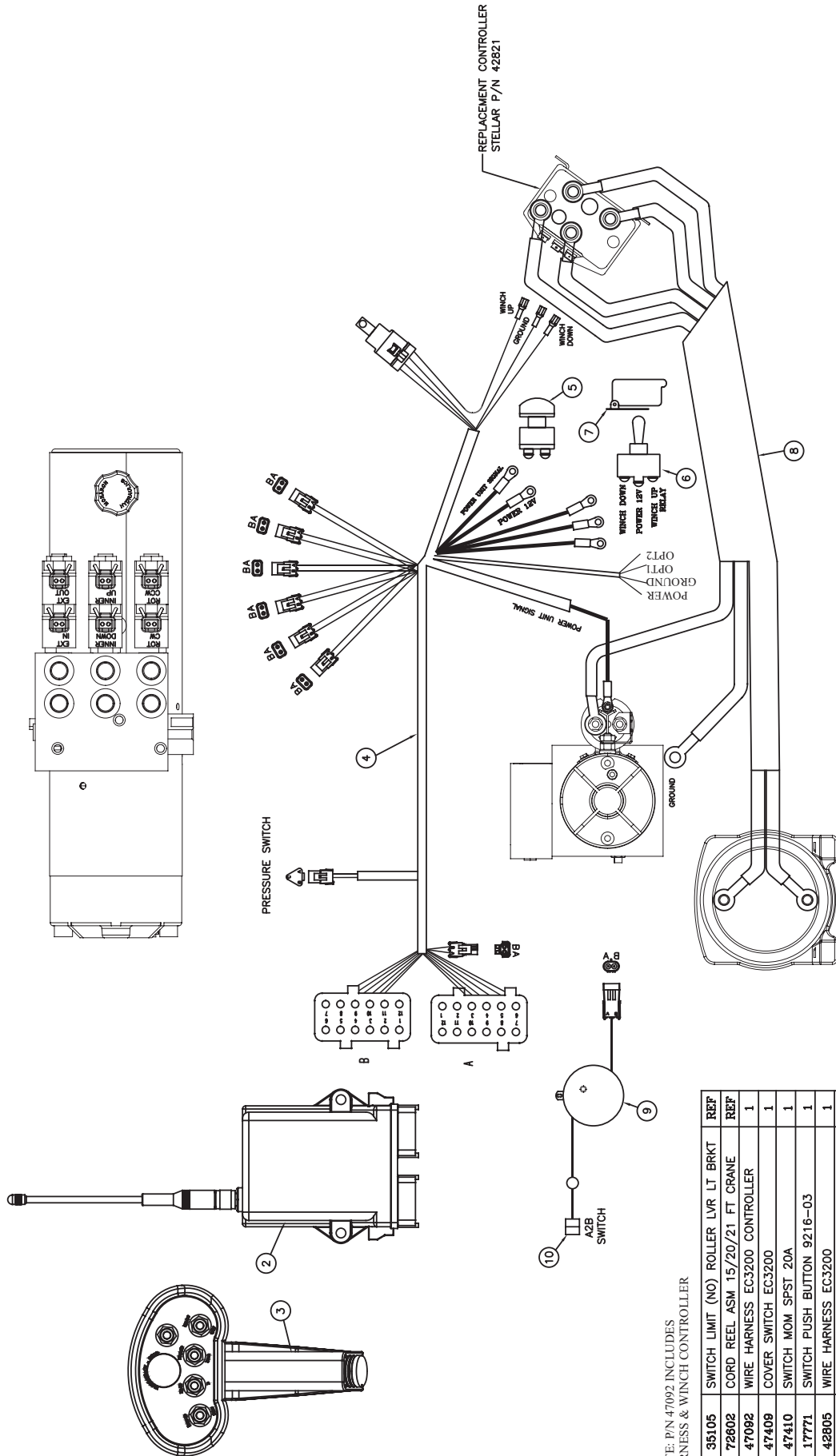

NOTE: P/N 47092 INCLUDES HARNESS & WINCH CONTROLLER

ITEM	PART No.	DESCRIPTION	QTY
10	35105	SWITCH LIMIT (NO) ROLLER LVR LT BRKT	REF
09	72802	CORD REEL ASM 15/20/21 FT CRANE	REF
08	47092	WIRE HARNESS EC3200 CONTROLLER	1
07	47409	COVER SWITCH EC3200	1
06	47410	SWITCH MOM SPST 20A	1
05	17771	SWITCH PUSH BUTTON 9216-03	1
04	42805	WIRE HARNESS EC3200	1
03	67894	TRANSMITTER-RADIO (PART OF 1)	REF
02		RECEIVER-RADIO (PART OF 1)	REF
01	39784	RADIO CNTRL ASM 5 FCN ON/OFF	1

# EC3200 Wiring Diagram (Two Battery)

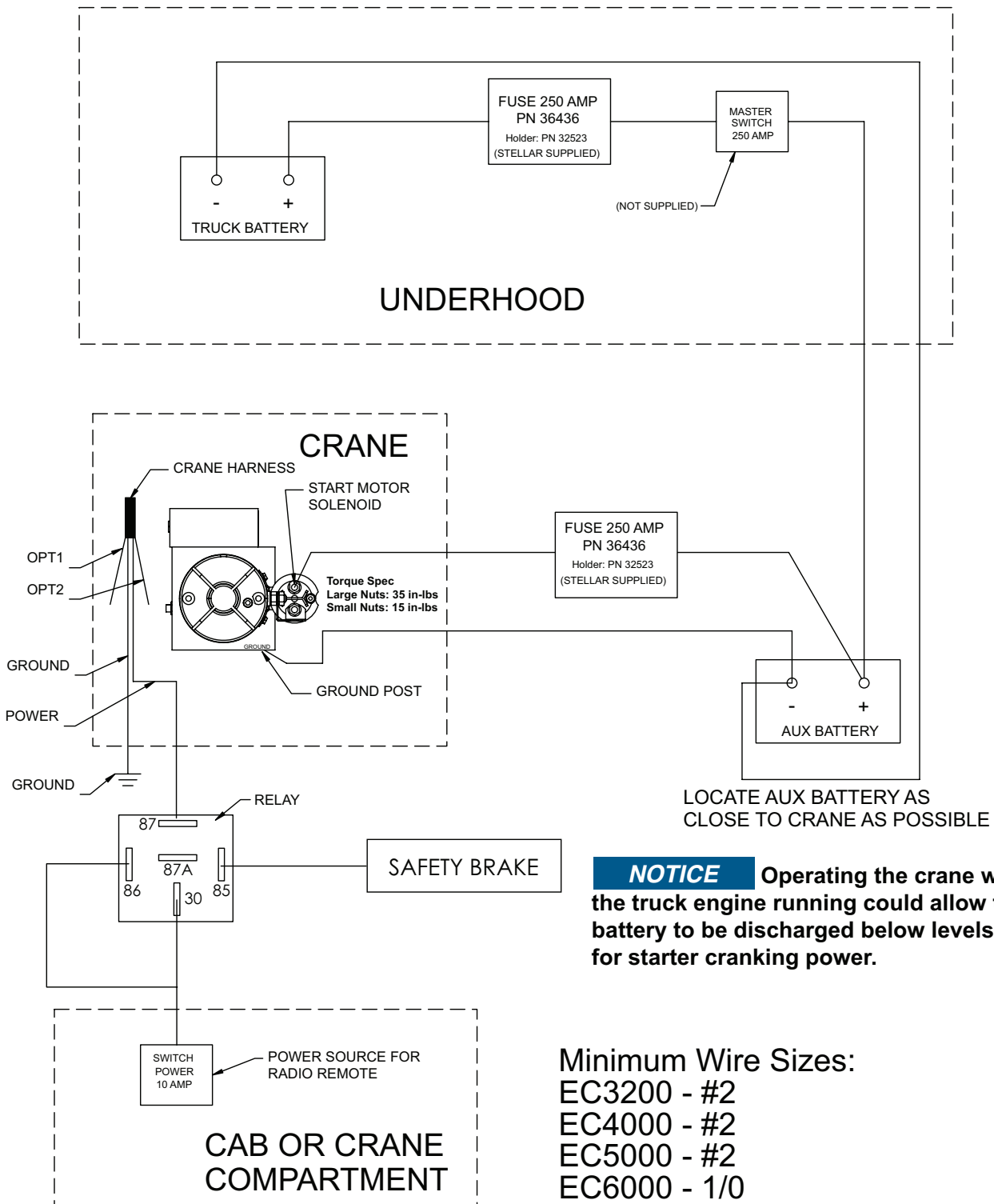

# EC3200 Wiring Diagram (One Battery)

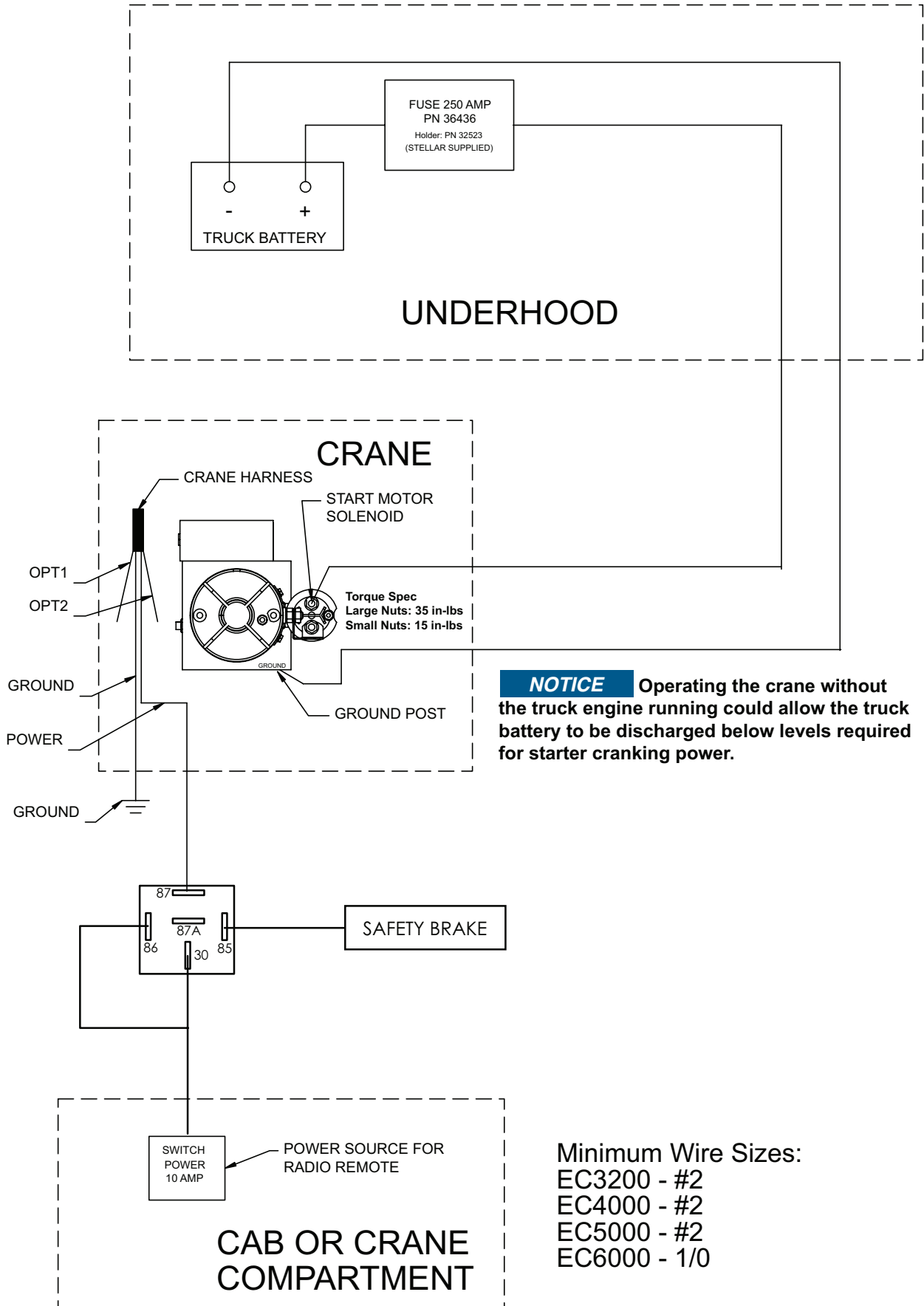

**NOTICE** Operating the crane without the truck engine running could allow the truck battery to be discharged below levels required for starter cranking power.

**Minimum Wire Sizes:**  
 EC3200 - #2  
 EC4000 - #2  
 EC5000 - #2  
 EC6000 - 1/0



# Electrical Circuit Grounding

When installing the crane, always locate a good source for grounding the circuit. A majority of electrical failures are due to poor grounding. Poor grounding can cause intermittent operation of the equipment, electrical component failures and cause the equipment to not operate at all.

Chassis manufacturers usually will have a ground strap which ties into the truck frame from the battery, but it is always a good idea to check each individual model to verify where the ground is located. Never use the mechanic body as a ground source. Make sure the electrical grounds are routed to either the chassis frame rail or the chassis's main grounding source.

Stellar provides a stud (PN 40992) for grounding the crane to the chassis frame rail:



Inside Frame Rail



Outside Frame Rail

- **⚠ WARNING** Drill the hole to the frame rail in accordance with the chassis body builder's guide.
- **Hole size: 21/64"**
- The hole location should allow for the shortest length of ground wire while keeping enough slack for flexibility.
- Be sure to grind the frame rail around the hole to ensure a proper ground connection.
- Frame rail thickness may require additional flat washers (as shown).
- Use an electrical coating on hardware to prevent corrosion.

# Stability Procedure

## Definition of Stability for the Stellar Telescopic Crane Products:

A truck is stable until the load cannot be lifted off the ground with the winch, without tipping over the truck. Every Stellar crane installed must be tested for stability to determine the actual load capacity of the final truck package. The actual test data must be recorded and supplied with the truck at the time of in-service and should be kept with the truck at all times. The following procedure will test the truck package for stability and will provide a stability capacity chart. The load limit information shown on the stability capacity chart is formulated on 85% tipping.

## Set Up:

1. Locate the truck on a test course in position for loading and engage travel brakes.
2. Set stabilizers so that they make contact with firm, level footings.
3. Operate the crane under partial load to assure operator proficiency and proper machine function.

## EC3200 Stability Data

**Max Horizontal Reach:** 180" (From the center of rotation to boom tip)

**Stability Test Weight:** 755 lbs.

## Test Procedure

1. Rotate the crane into Zone 1 position.
2. With the crane fully retracted and the boom horizontal, winch the test weight off the ground. Note: Keep weight within six inches of the ground at all times.
3. Extend the boom outward until full extension has been reached or until the truck becomes unstable (Again, use the winch to keep the weight within six inches of the ground.)
4. If the boom goes full extension without becoming unstable, the crane termed stable for this zone and 100% can be written in the Zone 1 data box.
5. If the truck becomes unstable prior to going full extension, retract the boom until the truck becomes stable and measure the horizontal reach in this position (center of rotation to boom tip). This is the stable horizontal reach for this zone. Stable horizontal reach divided by Maximum horizontal reach multiplied by 100 equals the percentage of rated capacity for this zone. Use the following formula to determine the percentage of rated capacity:

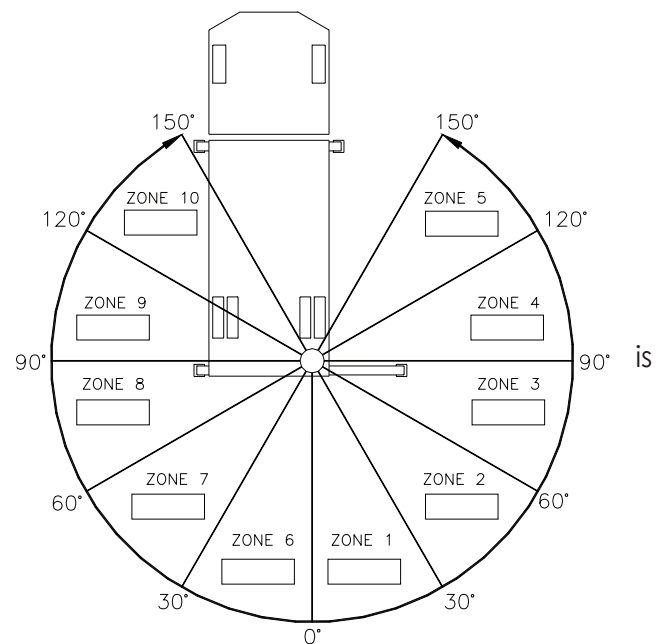

$$\frac{\text{Stable Horizontal Reach}}{\text{Max Horizontal Reach}} \times 100 = \text{Percentage of Rated}$$

6. Record this number in the data box for Zone 1. This is the revised capacity due to stability for this zone.
7. Repeat this procedure for each zone until the worksheet is completed.
8. This is the revised capacity based on stability of this package.

# Decal Kit Placement - PN 42816

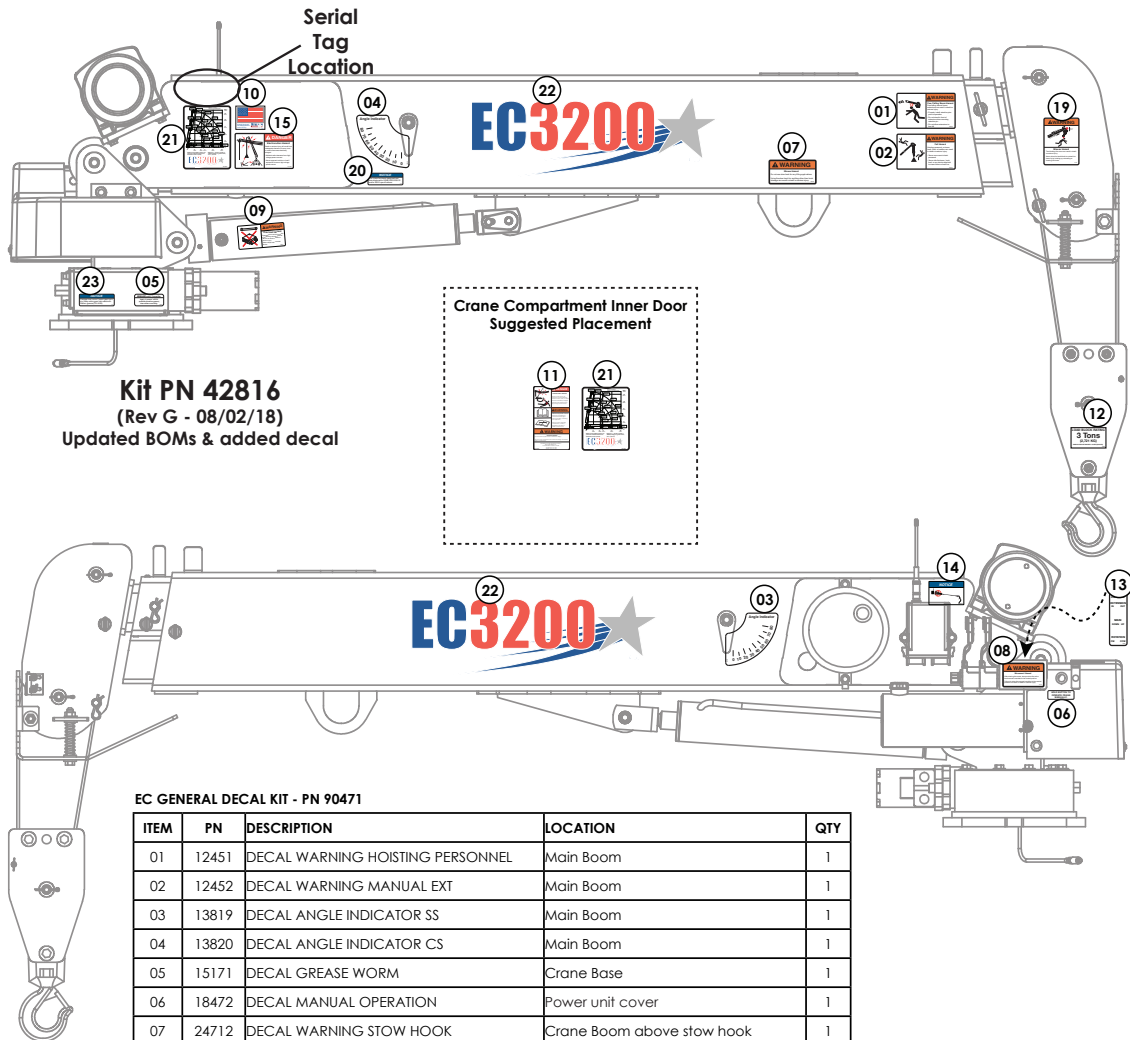

**Kit PN 42816**  
(Rev G - 08/02/18)  
Updated BOMs & added decal

## EC GENERAL DECAL KIT - PN 90471

ITEM	PN	DESCRIPTION	LOCATION	QTY
01	12451	DECAL WARNING HOISTING PERSONNEL	Main Boom	1
02	12452	DECAL WARNING MANUAL EXT	Main Boom	1
03	13819	DECAL ANGLE INDICATOR SS	Main Boom	1
04	13820	DECAL ANGLE INDICATOR CS	Main Boom	1
05	15171	DECAL GREASE WORM	Crane Base	1
06	18472	DECAL MANUAL OPERATION	Power unit cover	1
07	24712	DECAL WARNING STOW HOOK	Crane Boom above stow hook	1
08	25159	DECAL WARNING MANUAL OVERRIDES	Valve Bank	1
09	28256	DECAL WARNING OVERLOAD DEVICE	Main Cylinder	1
10	35234	DECAL STELLAR MADE IN THE USA	Main Boom	1
11	93936	DECAL SAFETY & SERVICE MECH BODY DOOR	Crane Compartment	1
12	42819	DECAL SNATCH BLOCK 3 TON	Snatch Block	1
13	42820	DECAL VB CONTROL EC SERIES	On top of valve bank	1
14	73929	DECAL PRESSURE WASH	Main Boom	1
15	C1179	DECAL DANGER ELECTROCUTION SMALL	Main Boom	1
16*	C4545	DECAL DANGER ELECTROCUTION LARGE	Four corners of the body/chassis	4
17*	C5910	DECAL STELLAR 4x9.5	Suggested: Rear body/tailgate	1
18*	C5911	DECAL STELLAR 2x4.5	Suggested: Side corners of body	3

## EC3200 DECAL KIT - PN 90484

ITEM	PN	DESCRIPTION	LOCATION	QTY
19	12300	DECAL WARNING TWO BLOCKING	Crane Horse Head	1
20	15172	DECAL ASME/ANSI B30.22/B30.5	Main Boom	1
21	42817	DECAL CAPACITY EC3200	Main Boom and Crane Compartment	2
22	42818	DECAL IDENTIFICATION EC3200	Main Boom (Both Sides)	2
23	9188	DECAL ROTATE/GREASE	Crane Base	1

\*Not Shown

This page intentionally left blank.

# Chapter 3 - Assembly Drawings

## Base Assembly - PN 42525

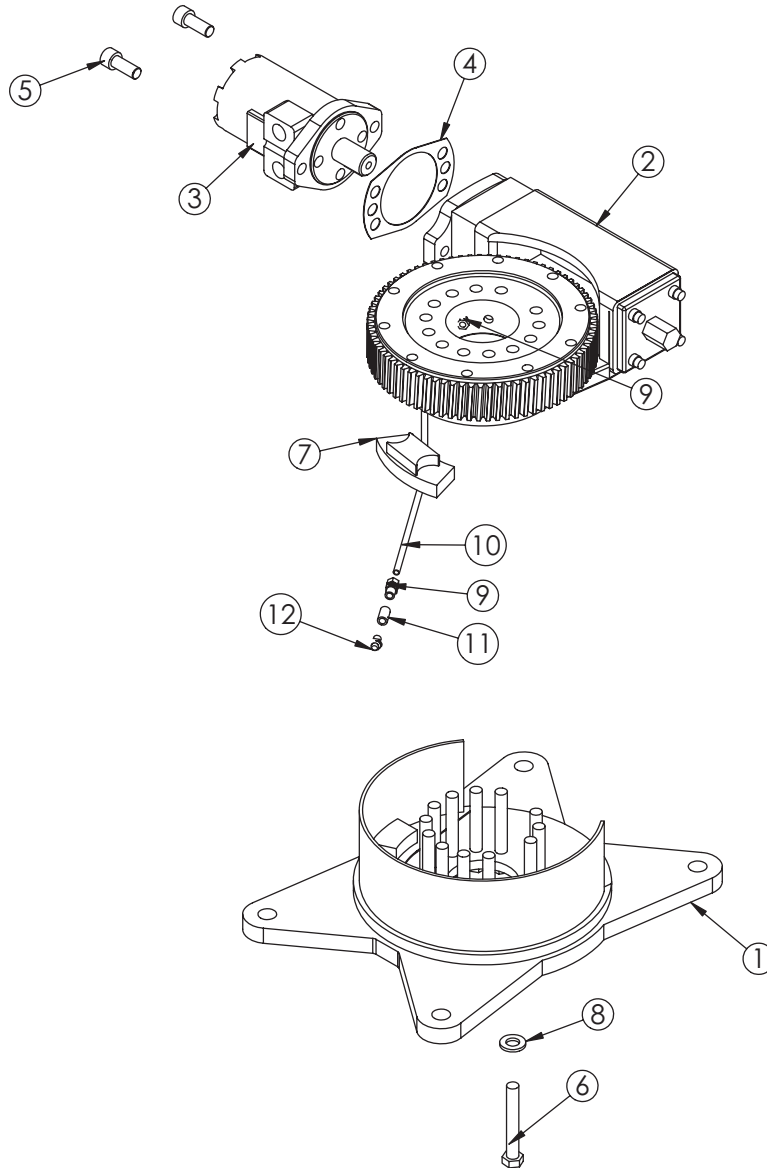

### PN 42525

ITEM	PART	DESCRIPTION	QTY.
1	42784	BASE EC3200	1
2	41640	BEARING SWING DRIVE 170-00058-1	1
3	62487	ROTATION MOTOR EC3200	1
4	21151	GASKET MOTOR 008-10056-1	1 ref
5	D1307	CAP SCR 0.50-13X1.25 SHGR8 W/ RED PATCH	2
6	30750	CAP SCR 0.50-13X3.50 HHGR8	13
7	42795	STOP SLIDING EC3200	1
8	D0790	WASHER 0.50 FLAT GR8	13
9	D1345	FTG CPRSN 0.12NPT/0.25 TUBE	2
10	D1810	TBE AIR SAEJ844 TYPE A .25 (RM)	2.5
11	22161	FTG 2-2 FP-FP COUPLER STRAIGHT BRASS	1
12	56589	ZERK 1/8 NPT STRAIGHT LONG THREAD	1

# Base Assembly (Narrow Version) - PN 44613

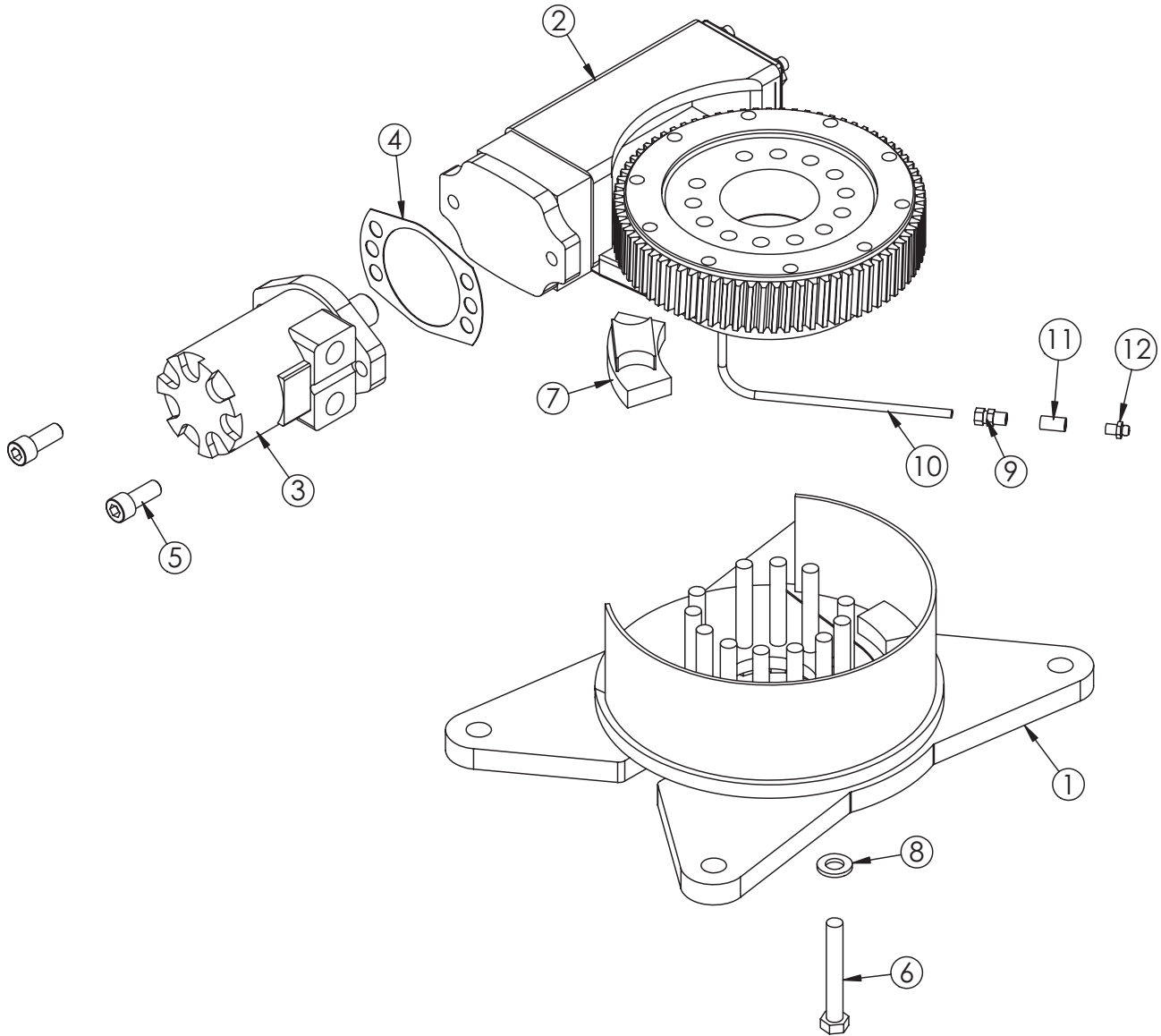

## PN 44613

ITEM	PART	DESCRIPTION	QTY.
1	44614	BASE EC3200 NARROW	1
2	41640	BEARING SWING DRIVE 170-00058-1	1
3	62487	ROTATION MOTOR EC3200	1
4	21151	GASKET MOTOR 008-10056-1	1 ref
5	D1307	CAP SCR 0.50-13X1.25 SHGR8 W/ RED PATCH	2
6	30750	CAP SCR 0.50-13X3.50 HHGR8	13
7	42795	STOP SLIDING EC3200	1
8	D0790	WASHER 0.50 FLAT GR8	13
9	D1345	FTG CPRSN 0.12NPT/0.25 TUBE	2
10	D1810	TBE AIR SAEJ844 TYPE A .25 (RM)	2.5
11	22161	FTG 2-2 FP-FP COUPLER STRAIGHT BRASS	1
12	56589	ZERK 1/8 NPT STRAIGHT LONG THREAD	1

# Mast Assembly - PN 42787

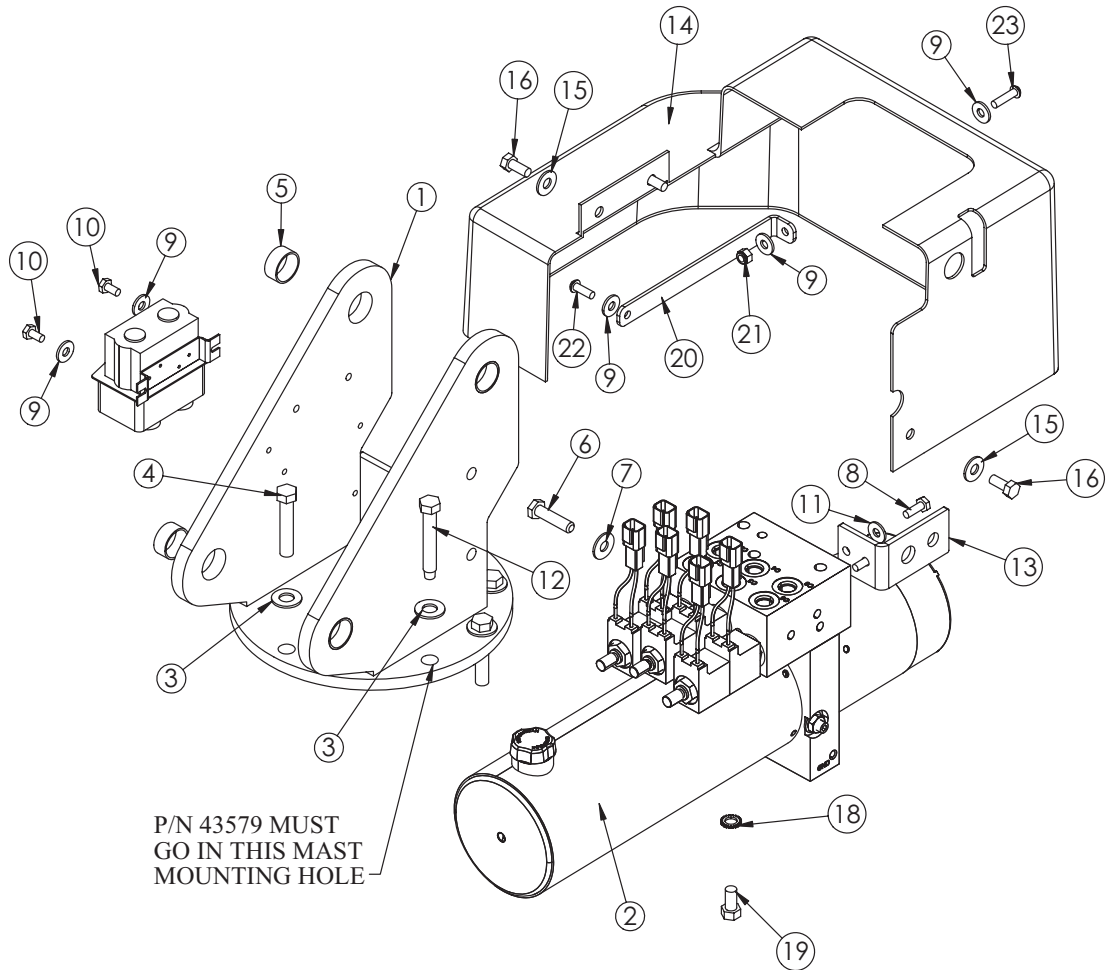

## PN 42787

ITEM	PART	DESCRIPTION	QTY.
1	42318	MAST EC3200	1
2	42513	POWER UNIT 12V EC3200	1
3	42788	WASHER 0.44 SAE FLAT YELLOW GR8	8
4	42789	CAP SCR 0.44-14X2.25 HHGR8 ZY	7
5	20362	BUSHING IGUS GFI-1618-08	4
6	0345	CAP SCR 0.38-16X1.50 HHGR5	2
7	0346	WASHER 0.38 FLAT	2
8	0479	CAP SCR 0.25-20X0.75 HHGR5	2
9	D0917	WASHER 0.25 FLAT SS	5
10	0478	CAP SCR 0.25-20X0.50 HHGR5	2
11	0340	WASHER 0.25 FLAT	2
12	43579	CAP SCR 0.44-14X2.75 MOD EC3200	1
13	47411	BRKT OVERRIDE BUTTON EC3200	1
14	44475	COVER EC3200 HDPE	1
15	0343	WASHER 0.31 USS FLAT ZINC	3
16	0420	CAP SCR 0.31-18X0.75 HHGR5	3
18	5870	WASHER 0.38 STAR EXTERNAL	1
19	0492	CAP SCR 0.38-16X0.75 HHGR5	1
20	51896	BRKT COVER EC CRANES	1
21	30659	NUT 0.25-20 HH NYLOC SS	1
22	C6021	CAP SCR 0.25-20X0.75 BTNHD SS	1
23	C6022	CAP SCR 0.25-20X1.00 BTNHD SS	1

NOTE: WINCH CONTROLLER(P/N 42821)  
SHOWN FOR REFERENCE

# Power Unit Assembly - PN 42513

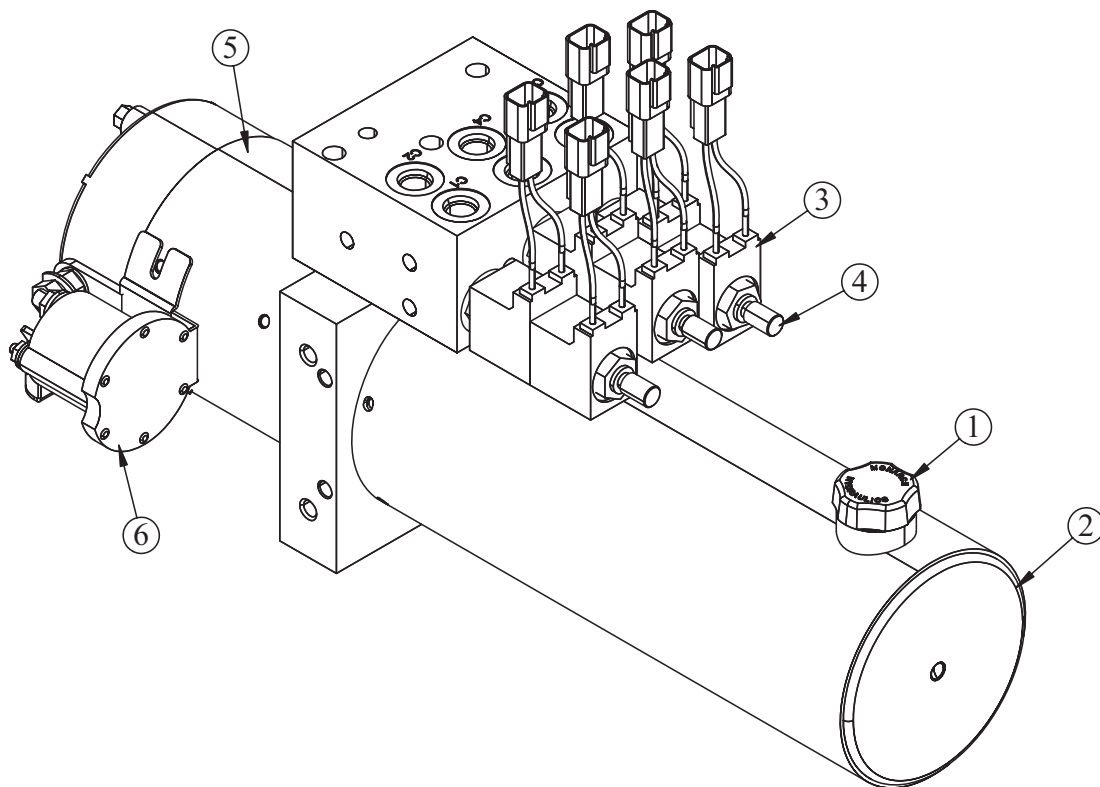

## PN 42513

ITEM	PART NUMBER	DESCRIPTION
1	44025	FILL CAP - HYDRAULIC RESERVOIR
2	44026	RSRVR EC3200 POWER UNIT
3	44027	VALVE COIL EC3200 POWER UNIT
4	44028	VALVE CARTRIDGE EC3200 UNIT
5	44029	MOTOR 12V EC3200 POWER UNIT
6	44030	SOLENOID START EC3200 P-UNIT



# Main Boom Assembly - PN 42512

**MOUNTING HARDWARE WILL  
BE PART OF THE WINCH PACKAGE.  
USE ALL HARDWARE, EXCEPT BOLTS.**

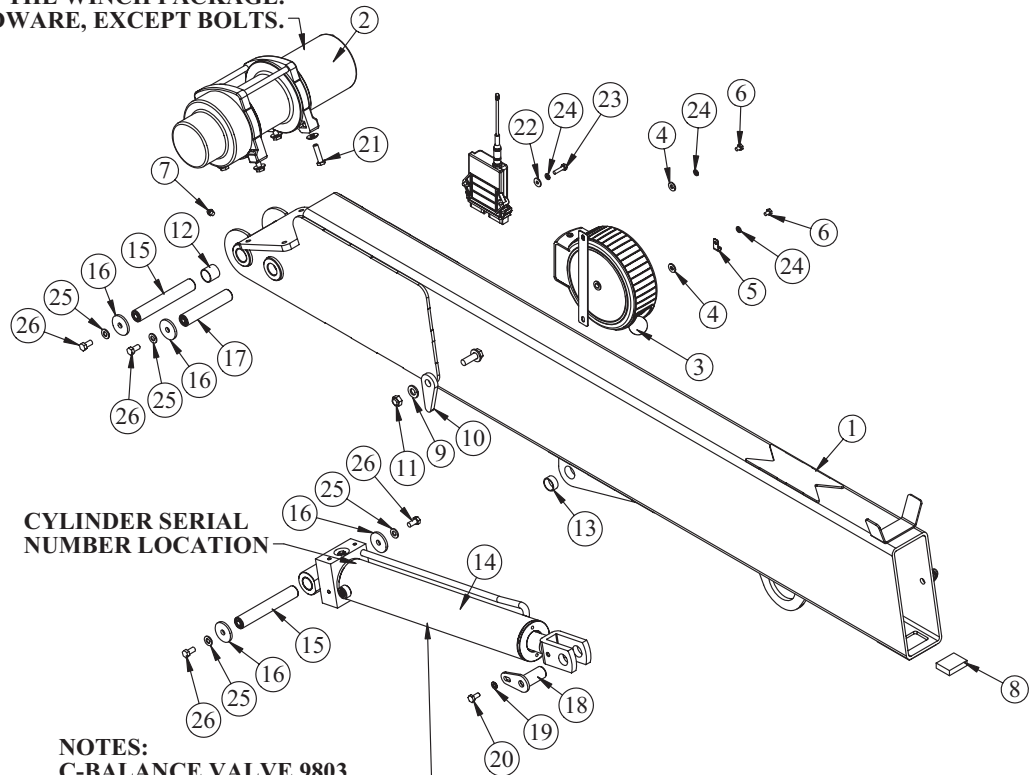

**CYLINDER SERIAL  
NUMBER LOCATION**

**NOTES:  
C-BALANCE VALVE 9803  
CYLINDER SEAL KIT 43892  
BUSHING PART NUMBER 0069  
BUSHINGS INCLUDED IN 42503**

## PN 42512

ITEM	PART	DESCRIPTION	QTY.
1	42303	INNER BOOM EC3200	1
2	41641	WINCH DC2000 WARN 63899	1
3	72602	CORD REEL ASM 15/21 FT CRANE	1
4	0340	WASHER 0.25 FLAT	2
5	C5606	CLAMP 0.25 BLK VINYL	1
6	43845	CAP SCR 0.25-20X0.38 HHGR5	2
7	c1592	ZERK 1/8 NPT STRAIGHT	1
8	42508	WEAR PAD 0.50X1.50X2.00	1
9	D0790	WASHER 0.50 FLAT GR8	4
10	13815	PLATE ANGLE INDICATR PC BLACK	2
11	C6106	NUT 0.50-13 HHGR5 NYLOC	2
12	0069	BUSHING QSI-1618-16	2
13	20362	BUSHING BPC16DXR08 1.00X.50	1
14	42503	CYLINDER 3.00X13.00 EC3200	1
15	11688CR	PIN 1.00X6.31 D&T ZC	2
16	9320	PIN CAP 0.44X1.75X0.19 YZ	6
17	42516CR	PIN 1.00X5.13 D&T ZC	1
18	42517CR	PIN TEAR DROP 1.00X2.19 ZC	1
19	5591	WASHER 0.31 SAE FLAT YELLOW GR8	1
20	53521	CAP SCR 0.31-18X0.75 HHGR8	1
21	0345	CAP SCR 0.38-16X1.50 HHGR5	4
22	D0917	WASHER 0.25 FLAT SS	2
23	0480	CAP SCR 0.25-20X1.00 HHGR5	2
24	0521	WASHER 0.25 LOCK	4
25	C6353	WASHER 0.38 SAE FLAT YELLOW GR8	6
26	9843	CAP SCR 0.38-16X0.75 HHGR8	6

# Extension Boom Assembly - PN 42520

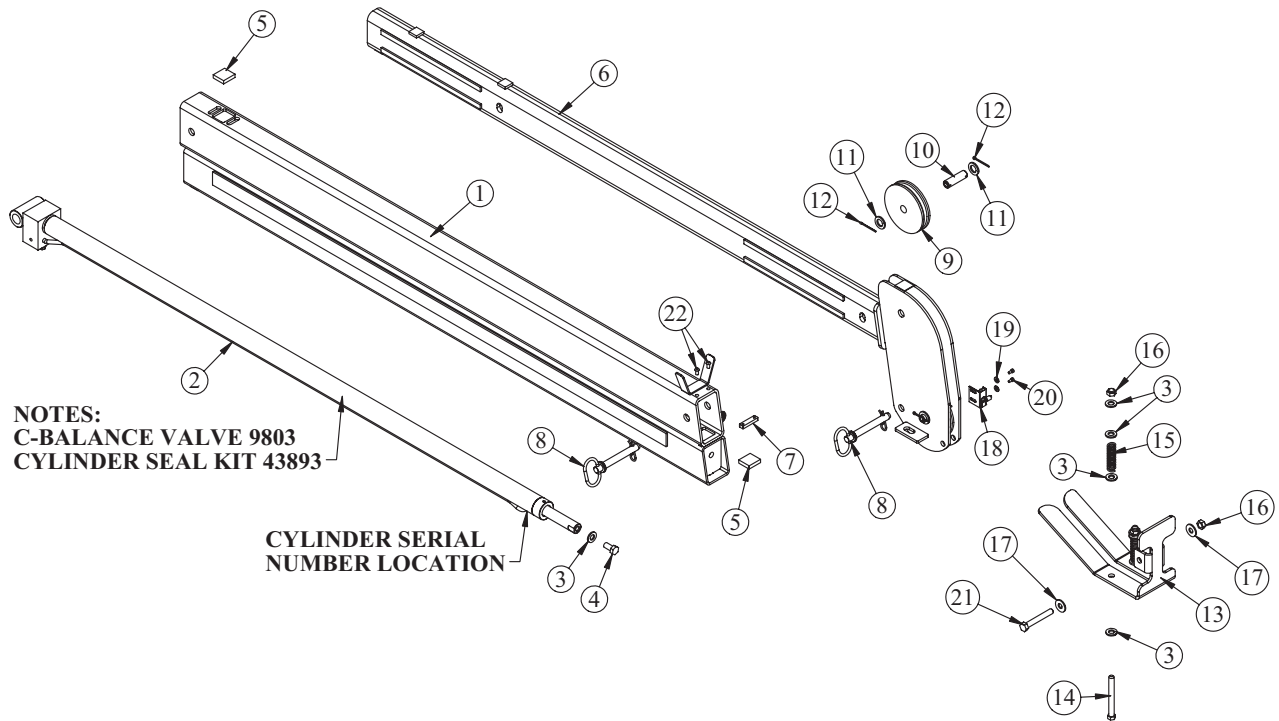

## PN 42520

ITEM	PART	DESCRIPTION	QTY.
1	42311	EXT BOOM 1ST EC3200	1
2	42507	CYLINDER 1.50X48.00	1
3	D0790	WASHER 0.50 FLAT GR8	9
4	10172	CAP SCR 0.50-13X1.00 HHGR8 ZY	1
5	42509	WEAR PAD 0.38X1.38X1.50	2
6	42312	EXT BOOM 2ND EC3200	1
7	42978	FLAT BOOM STOP EC3200 PC BLACK	1
8	42977	PIN HITCH 0.63X4.00	2
9	42317	SHEAVE EC3200 5.00 DIA .22R/1.00THK	2
10	42524CR	PIN 0.75X2.50 COTTER ZC	2
11	0423	MACHY WASHER 0.75ID 10GA	4
12	37824	COTTER PIN .125X1.00	4
13	42505	PLATE CRADLE EC3200 PC BLACK	1
14	0507	CAP SCR 0.50-13X4.50 HHGR5	2
15	27710	SPRING ANTI 2 BLOCK CRADLE A2B	2
16	C6106	NUT 0.50-13 HHGR5 NYLOC	3
17	0352	WASHER 0.50 USS FLAT ZINC	2
18	35105	SWITCH LIMIT E1117-B9111-6C	1
19	D0178	WASHER #10 SAE FLAT ZINC	2
20	43846	SCREW #10-24X0.38 SH SS	2
21	0505	CAP SCR 0.50-13X3.50 HHGR5	1
22	D0561	CAP SCR 0.25-20X0.50 BTNHD SS	2

# Cable & Hook Assembly - PN 42781

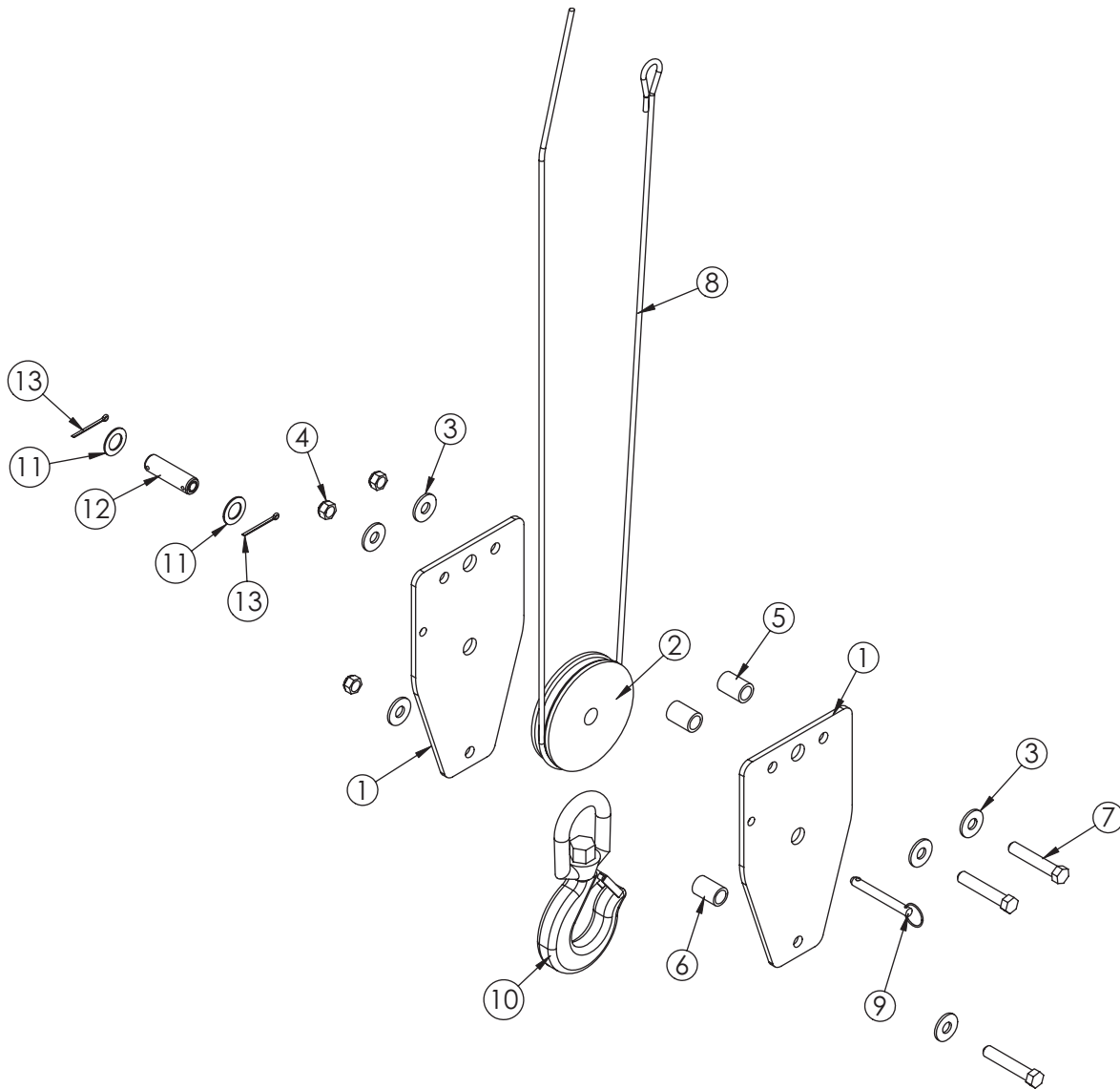

## PN 42781

ITEM	PART	DESCRIPTION	QTY.
1	42523PC	PLATE SNATCH BLOCK EC3200	2
2	42317	SHEAVE EC3200 5.00 DIA .22R/1.00THK	1
3	0352	WASHER 0.50 USS FLAT ZINC	6
4	5468	NUT 0.50-13 HHGR8 NYLOC	3
5	27810	SPACER 3315 SNATCH BLOCK UHMW	2
6	16607PC	SPACER 3315 SNATCH BLOCK	1
7	47868	CAP SCR 0.50-13X2.75 HHGR8	3
8	42316	WIRE ROPE 7/32 7X19 GAC 65FT	1
9	9263	PIN .38X3.00 QUICK RELEASE	1
10	C6018	HOOK CRANE-3 TON	1
11	0375	MACHY WASHER 0.75ID 14GA	2
12	42524ZP	PIN 0.75X2.50 COTTER	1
13	37824	COTTER PIN .125X1.00	2

# Gear Bearing Assembly - PN 41640

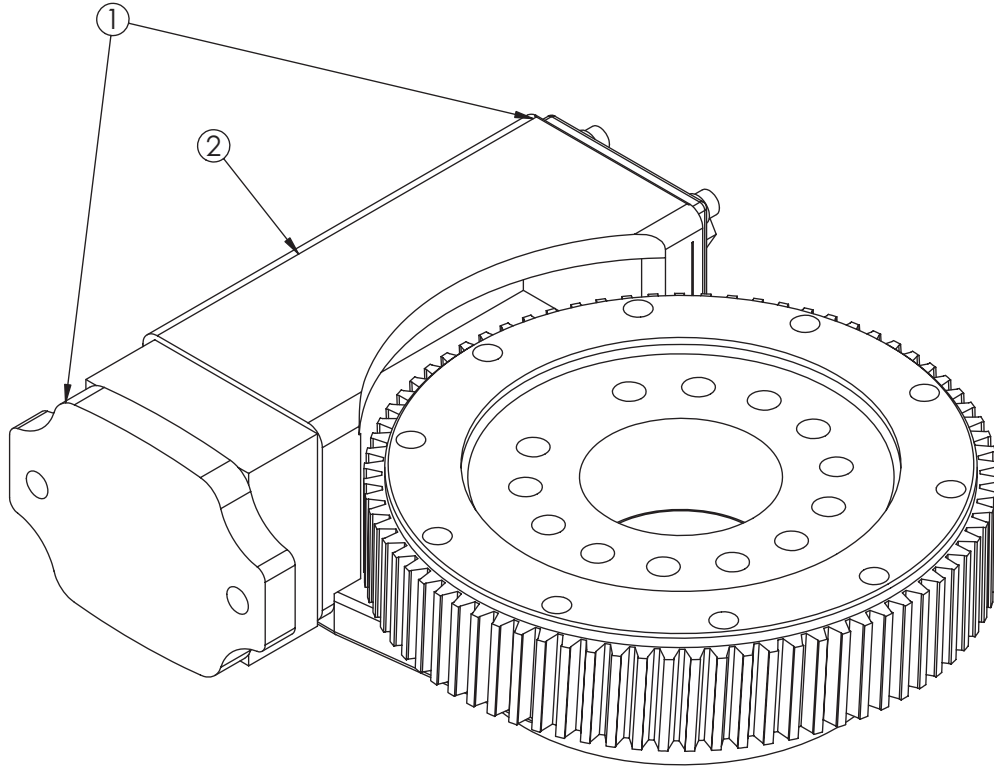

## PN 41640

ITEM	PART	DESCRIPTION	QTY.
1	44383	BEARING AND SEAL KIT EC3200 GP	1
2	44375	WORM EC3200 GEAR PROD 170-10081-1	1

ITEM	PART	DESCRIPTION	QTY.
1	77737	BEARING AND SEAL KIT EC3200 KNMTS	1
2	77738	WORM EC3200 KNMTS	1

# Radio Transmitter Assembly - PN 67894

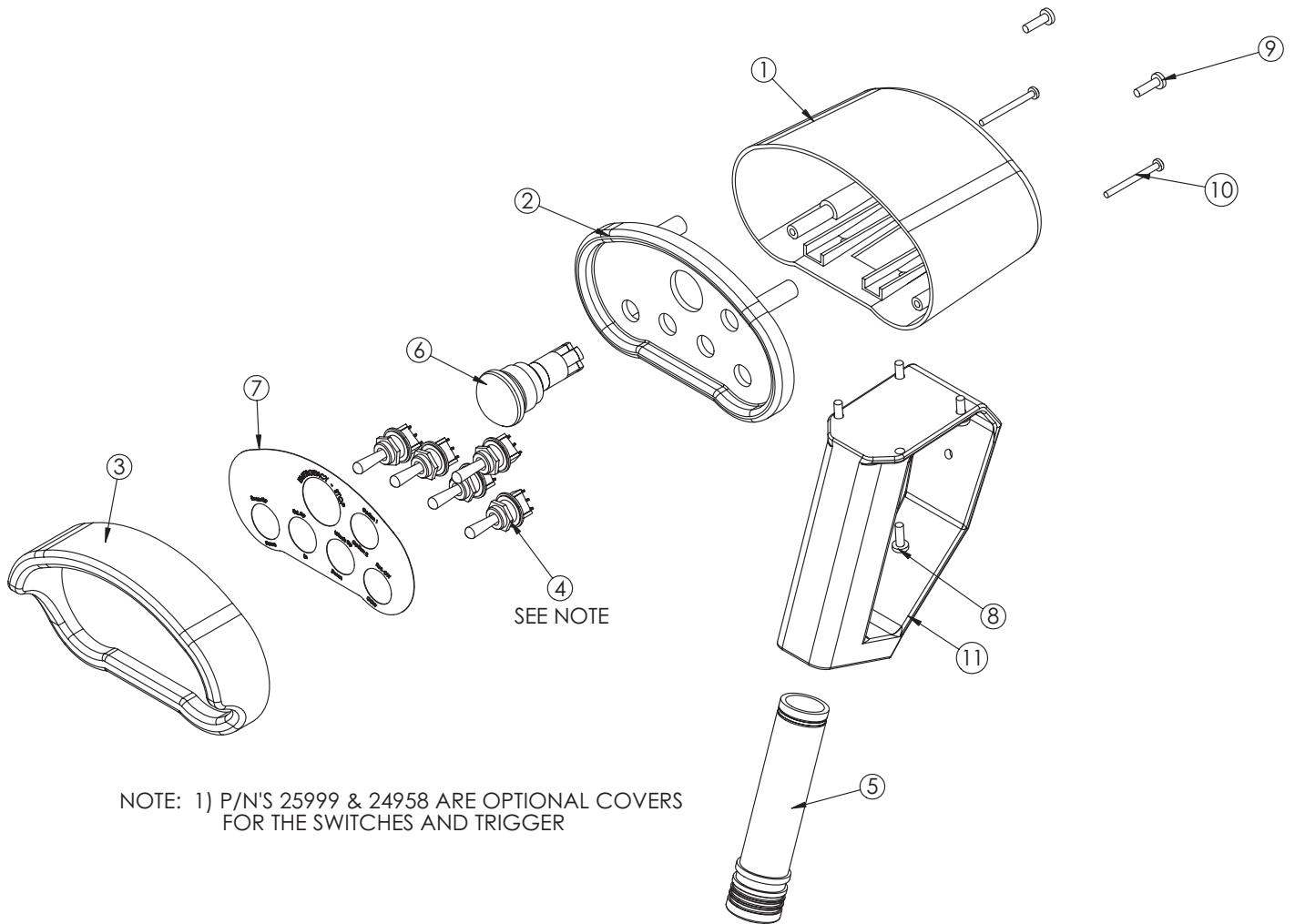

## PN 67894

ITEM	PART	DESCRIPTION	QTY.
1	20088	CONTROL HANDLE HOUSING 4 FCTN HET	1
2	51830	CONTROL HANDLE FACE PLT 5 FCTN	1
3	24385	GUARD RADIO SWITCH 4 FCTN	1
4	22600	SWITCH TOGGLE HET RADIO 63019300	5
5	35441	BATTERY TUBE AA HETRONIC RADIO	1
6	16975	SWITCH E STOP ASM HETRONIC RADIO	1
7	51831	DECAL CONTROL HANDLE 5 FCTN	1
8	38475	SCREW 4MMX12MM PHMS PH	4
9	36156	SCREW 4MMX14MM PHMS PH	2
10	29460	SCREW 3MMX35MM PHMS PH	2
11	50932	CONTROL HANDLE GRIP LESS TRIGGER HET H2	1

**This page intentionally left blank.**

# Chapter 4 - Replacement Parts

## HYDRAULIC COMPONENTS

PART#	DESCRIPTION
42840	HYDRAULIC SWING MOTOR
21151	GASKET - HYDRAULIC SWING MOTOR
42513	POWER UNIT 12V EC3200
44028	VALVE CARTRIDGE - POWER UNIT 12V #19012-D
44027	VALVE COIL - POWER UNIT 12V #11494-D
44029	MOTOR 12V - POWER UNIT #08111-1
44030	12V SOLENOID (12volt hydraulic system) #17757
44026	HYDRAULIC RESERVOIR - POWER UNIT 12V #14071
44025	FILL CAP - HYDRAULIC RESERVOIR
9803	C-BALANCE VALVE
16405	COUNTER BALANCE VALVE (EXTEND SIDE OF CYLINDERS)
43892	SEAL KIT - MAIN LIFT CYLINDER
43893	SEAL KIT - EXTENSION CYLINDER
49315	PRESSURE SWITCH
42821	CONTROLLER SOLENOID
C2027	O'RING - # 4 FACE SEAL
C2028	O'RING - # 6 FACE SEAL
D1245	O'RING - # 4 SAE
D1246	O'RING - # 6 SAE

## ASSEMBLY COMPONENTS

44375	WORM GEAR - ROTATION BEARING
44383	BEARING & SEAL KIT - ROTATION BEARING
44376	BEARING RETAINER - ROTATION BEARING
44377	ADAPTER HOUSING - HYDRAULIC MOTOR
20362	BUSHING 1.00" X 0.50"
0069	BUSHING 1.00" X 1.00"
42508	WEAR PAD 0.38" X 1.50" X 2.00"
42509	WEAR PAD 0.38" X 1.38" X 1.50"
42978	BOOM STOP FLAT
9320	PIN CAP 0.44" X 1.75" X 0.25" SS
C6353	WASHER 0.38 FLAT GR8
13573	CAP SCR. 0.38-16 X 1.00" GR8
0375	MACHINE WASHER -0.75" ID 14GA.
0423	MACHINE WASHER -0.75" ID 10GA.
42317	SHEAVE
42316	WIRE ROPE
42977	HITCH PIN 0.63" X 4.00"
9263	QUICK RELEASE PIN .38 X 3.00"
42505PC	CRADLE PLATE
27710	SPRING ANTI-2-BLOCK
C6018	HOOK 3-TON
10709	SAFETY LATCH FOR 3 TON HOOK
C1592	GREASE ZERK

## ELECTRICAL COMPONENTS

35105	LIMIT SWITCH
11544	CORD REEL
17771	PUSH BUTTON (12volt hydraulic system)
47410	MOMENTARY SWITCH
41641	WINCH
28978	BOSCH RELAY
36436	FUSE 250 AMP

## RADIO REMOTE COMPONENTS

42976	RADIO REMOTE SYSTEM
50932	HANDLE ASM
16975	E-STOP SWITCH
22600	TOGGLE SWITCH
20088	LOWER TRANSMITTER HOUSING
35441	BATTERY TUBE HOLDER
35916	BACK UP CORD



Subject to Change without Notification.  
© 2018 Stellar Industries, Inc.