



CRANE MODEL 9620

280 W. 3rd St., Box 169 • Garner, IA 50438 • Phone: 641-923-3741 • Fax: 641-923-2812

UPDATED 10/20/03

TABLE OF CONTENTS

STELLAR CRANE 9620

PAGE	DESCRIPTION
3.)	SPECIFICATION SHEET
4.)	CAPACITY CHART
5.)	CRANE OPERATION – 4 FUNCTION
6.)	CRANE OPERATION – 7 FUNCTION
7.)	MANUAL OPERATION
8.)	BASE ASSEMBLY
9.)	MAST ASSEMBLY
10.)	MAIN BOOM ASSEMBLY
11.)	CYLINDER ASSEMBLY
12.)	EXTENSION BOOM ASSEMBLY
13.)	CYLINDER ASSEMBLY
14.)	CABLE AND HOOK ASSEMBLY
15.)	WIRE ROPE/SHEAVE CONFIGURATIONS
16.)	CONTROL KIT – 4 FUNCTION
17.)	CONTROL KIT – 7 FUNCTION
18.)	HYDRAULIC KIT
19.)	INSTALLATION KIT
20.)	DECAL KIT
21.)	STABILITY PROCEDURE
22.)	STABILITY CHART
23.)	WARRANTY STATEMENT

Model 9620 Crane SPECIFICATION SHEET

Crane Rating	55,000 ft-lbs (7.60 ton-meters)
Standard Boom Length	9'4"(2.85 m) from CL of Crane
Boom Extension	1 st stage: Hydraulic 60"(152.4 cm) 2 nd stage: Hydraulic 60"(152.4 cm)
Maximum Horizontal Reach	20'9"(6.32 m) from CL of Crane
Maximum Vertical Lift (from crane base)	22'(6.71 m)
Boom Elevation	-5 to +80 degree
Winch Specification	
Rope Diameter	7/16"(0.95 cm)
Line pull speed	60 ft/min (18.29 m/min)
Max. single part line	4300 lbs (1950 kg)
Max. double part line	8600 lbs (3900 kg)
Rotation	400 degree power (worm gear)
Lifting Capacities	5100 lbs @ 10'9"(2315 kg @ 3.28m) 3475 lbs @ 15'9"(1575 kg @ 4.80m) 2650 lbs @ 20'9"(1200 kg @ 6.32m)
Power Supply Required	PTO & Pump (8 gpm @ 3000 psi) (30.3 lpm @ 207 bar)
Controls	Radio control standard for all functions.
Stowed Height (crane only)	34 inches (86.4 cm)
Mounting Space Required	20 x 21 inches (50.8 x 53.3 cm)
Approximate Shipping Weight	2120 lbs (960 kg)

CAPACITY CHART

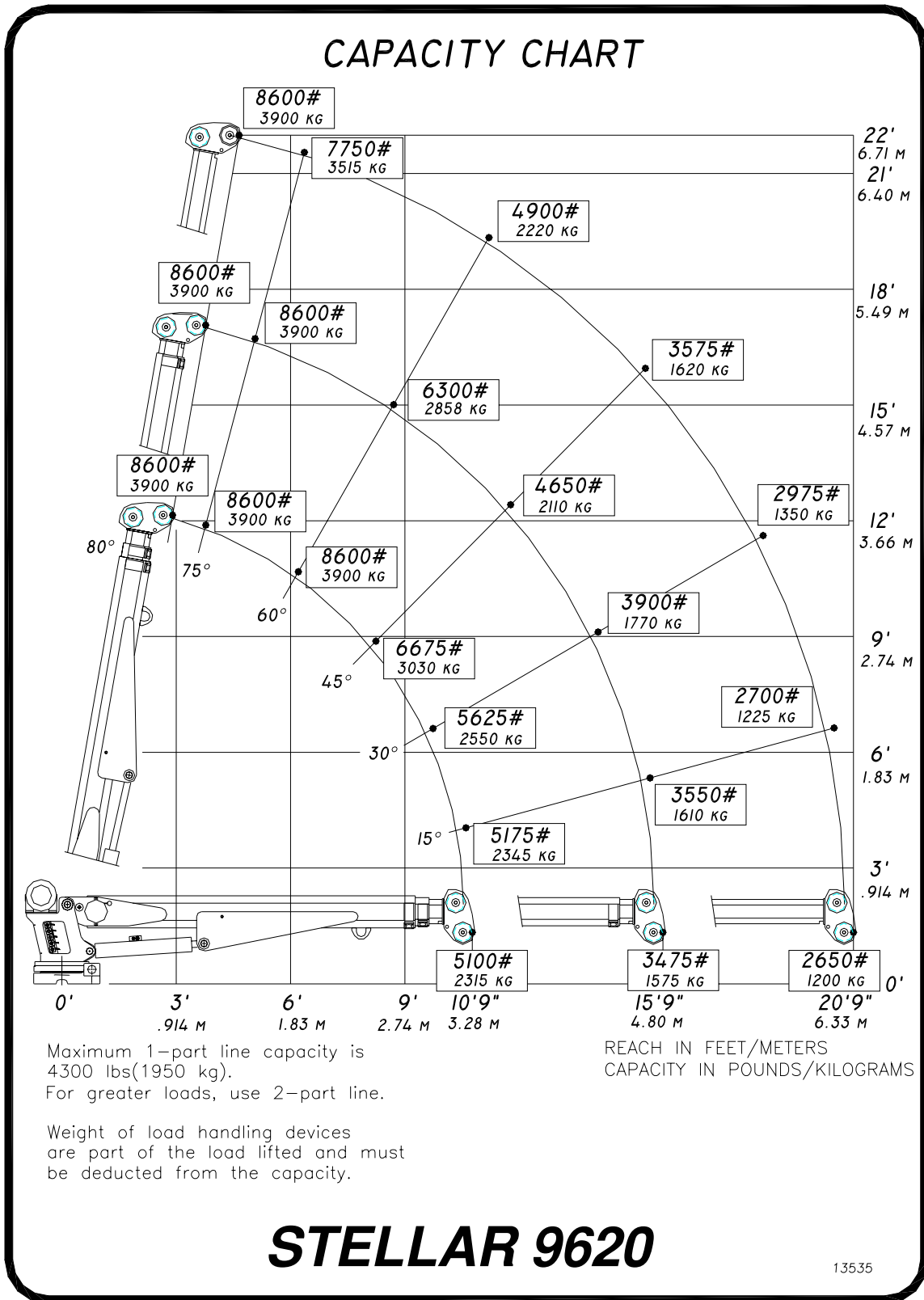

CRANE OPERATION – 4 FUNCTION

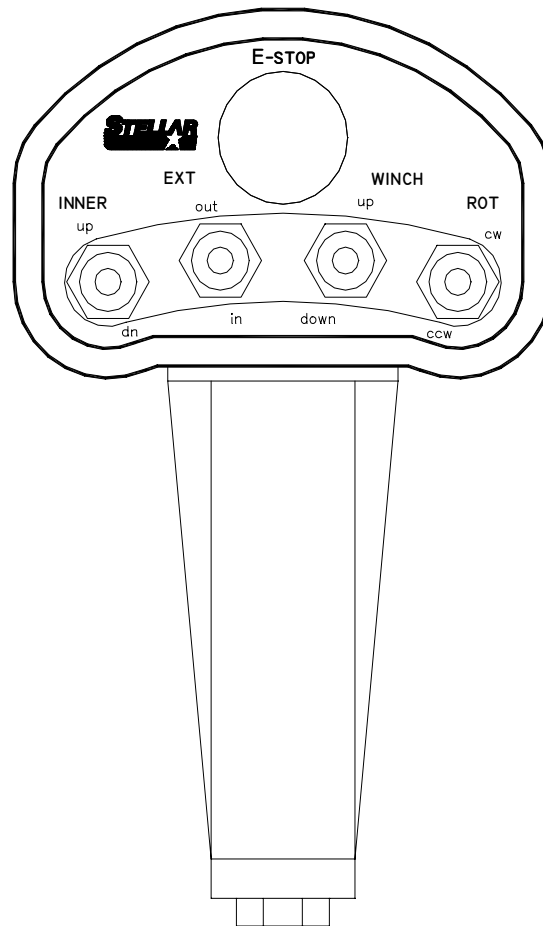

This crane is operated by a radio control system which operates an electronic valve bank. The controller (as shown) operates the following functions:

- main boom up and down
- extension boom in and out
- winch up and down
- rotation cw and ccw

To operate crane, activate the desired toggle switch. The crane will not function until the trigger on the remote handle is activated. The crane speed will change as the trigger is pulled or released.

NOTE: If the crane does not operate, check the batteries located in the remote handle and replace if necessary.

CRANE OPERATION – 7 FUNCTION

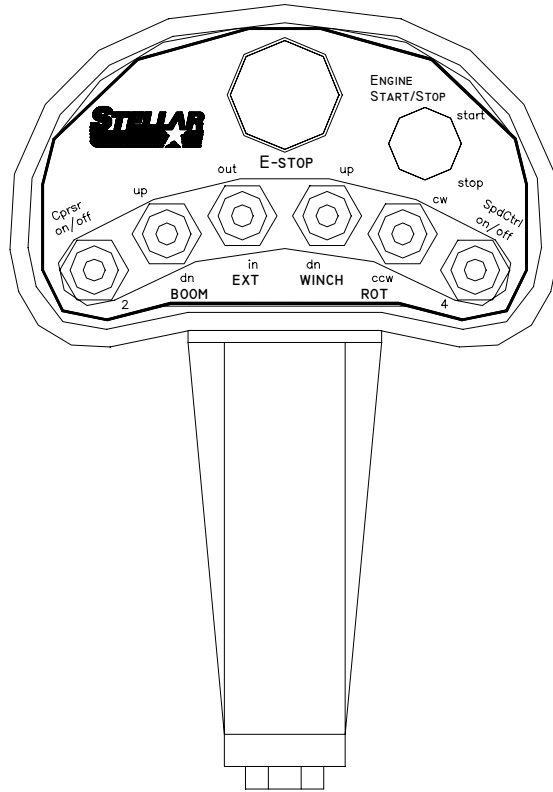

This crane is operated by a radio control system which operates an electronic valve bank. The controller (as shown) operates the following functions:

- main boom up and down
- extension boom in and out
- winch up and down
- rotation cw and ccw

This controller can also be utilized to operate the following optional functions:

- engine start and stop
- speed control on and off
- compressor on and off

Two optional functions are also available for other customer needs. Option two and option four are both momentary 12 volt functions and will require a latching relay for most installations.

MANUAL OPERATION

IN CASE OF RADIO FAILURE THE CRANE CAN BE OPERATED USING MANUAL OVERRIDES LOCATED ON THE VALVE BANK.

VALVE MANUAL OVERRIDE OPERATION

1. **ACTIVATE FLOW CONTROL**
TURN OVERRIDE SCREW ON FLOW CONTROL OUT.
2. **OPERATE SOLENOIDS**
UNLATCH THEN PUSH OR PULL TO OPERATE.
3. **DEACTIVATE FLOW CONTROL**
TURN OVERRIDE SCREW ON FLOW CONTROL IN.
4. **HAVE UNIT SERVICED**

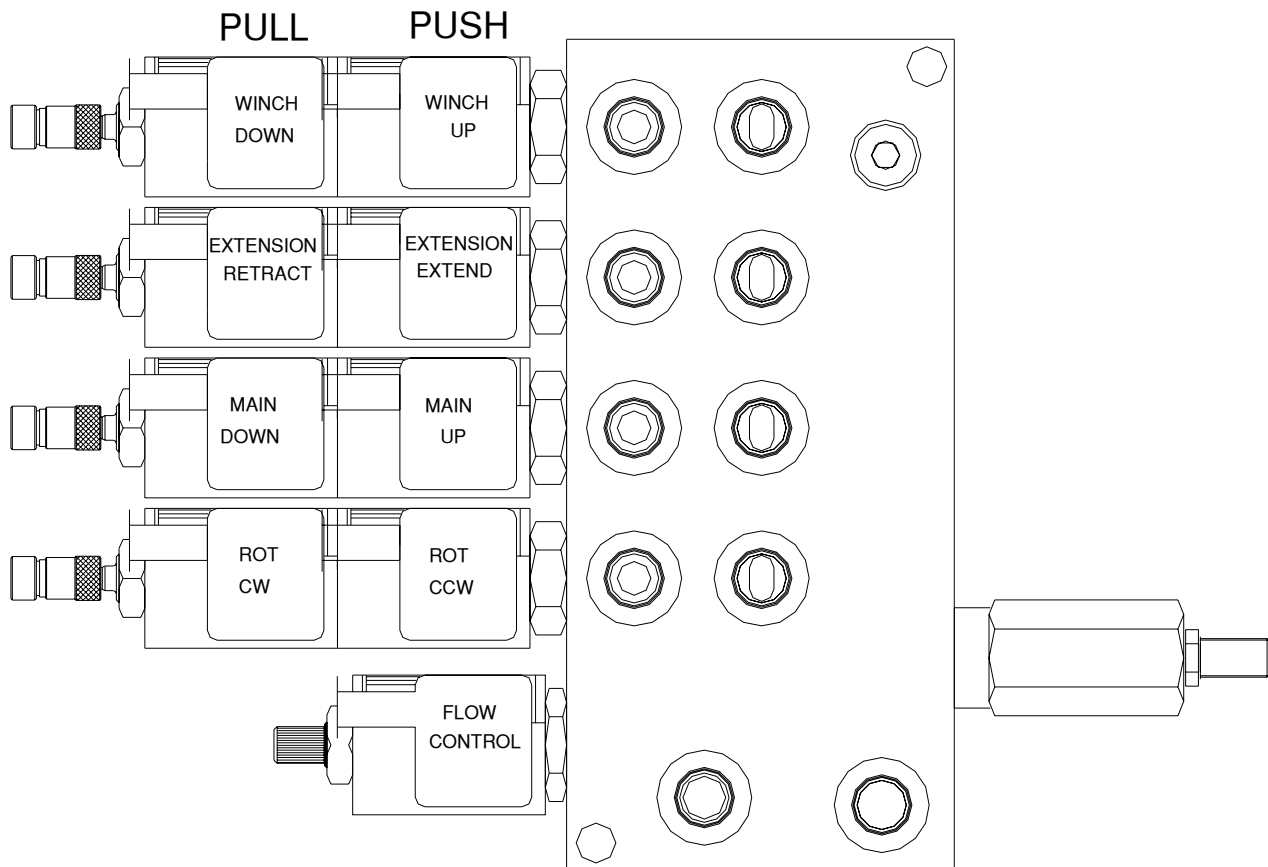

BASE ASSEMBLY P/N 18027

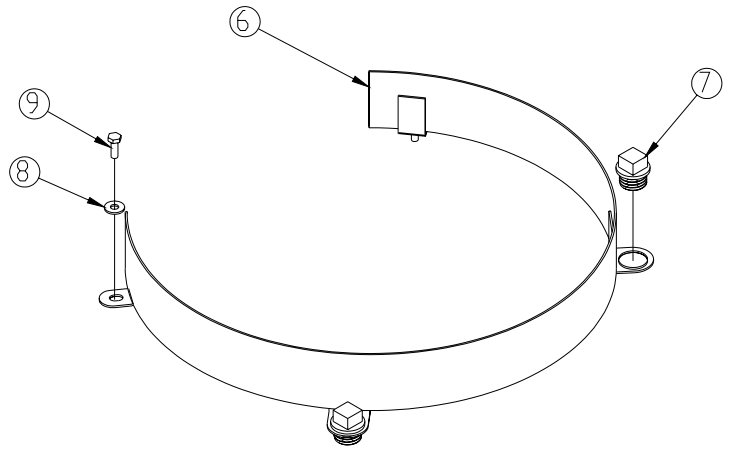

GASKET SHOWN AS REFERENCE

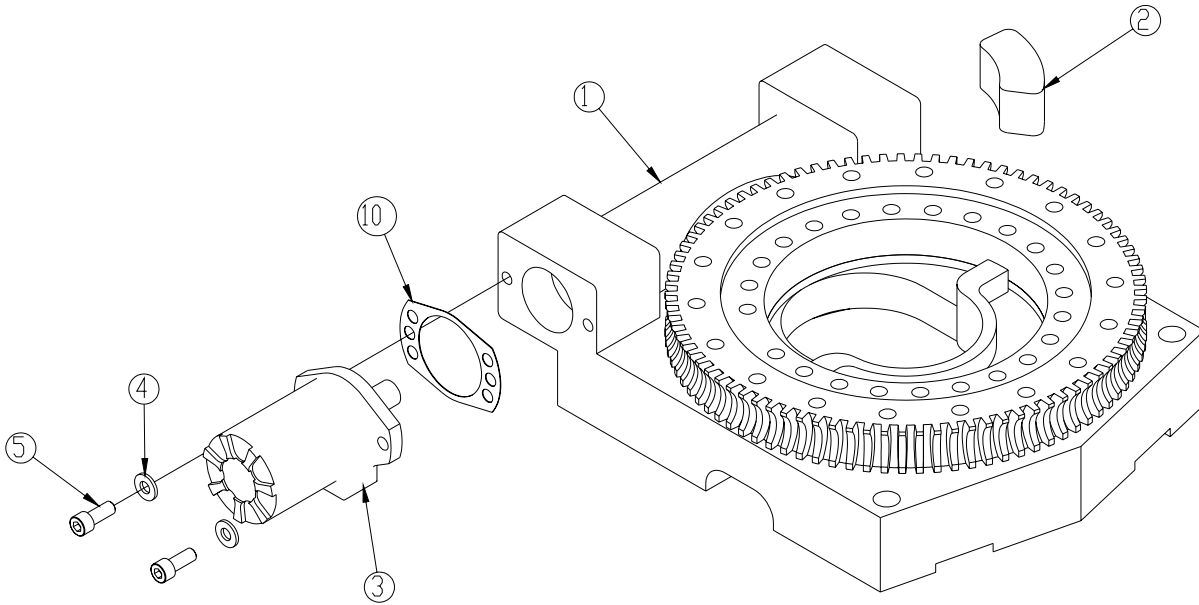

ITEM	PART	DESCRIPTION	QTY.	ITEM	PART	DESCRIPTION	QTY.
1	11453	BEARING SWING DRIVE CAST BASE 6620	1	6	12730	GUARD TTB 6620 CRANE	1
2	11542	STOP 3820 400 SLIDE	1	7	13959	CAP SCR 1.00-8 X .63 PLASTIC	2
3	C6069	MOTOR HYD ROSS MK080613AAAB	1	8	0340	WASHER 0.25 FLAT	2
4	D0790	WASHER 0.50 FLAT GR8	2	9	0479	CAP SCR 0.25-20X0.75 HHGR5	2
5	D1307	CAP SCR 0.50-13X1.25 SH	2	10	21151	GASKET MOTOR 008-10056-1	1

MAST ASSEMBLY P/N 18028

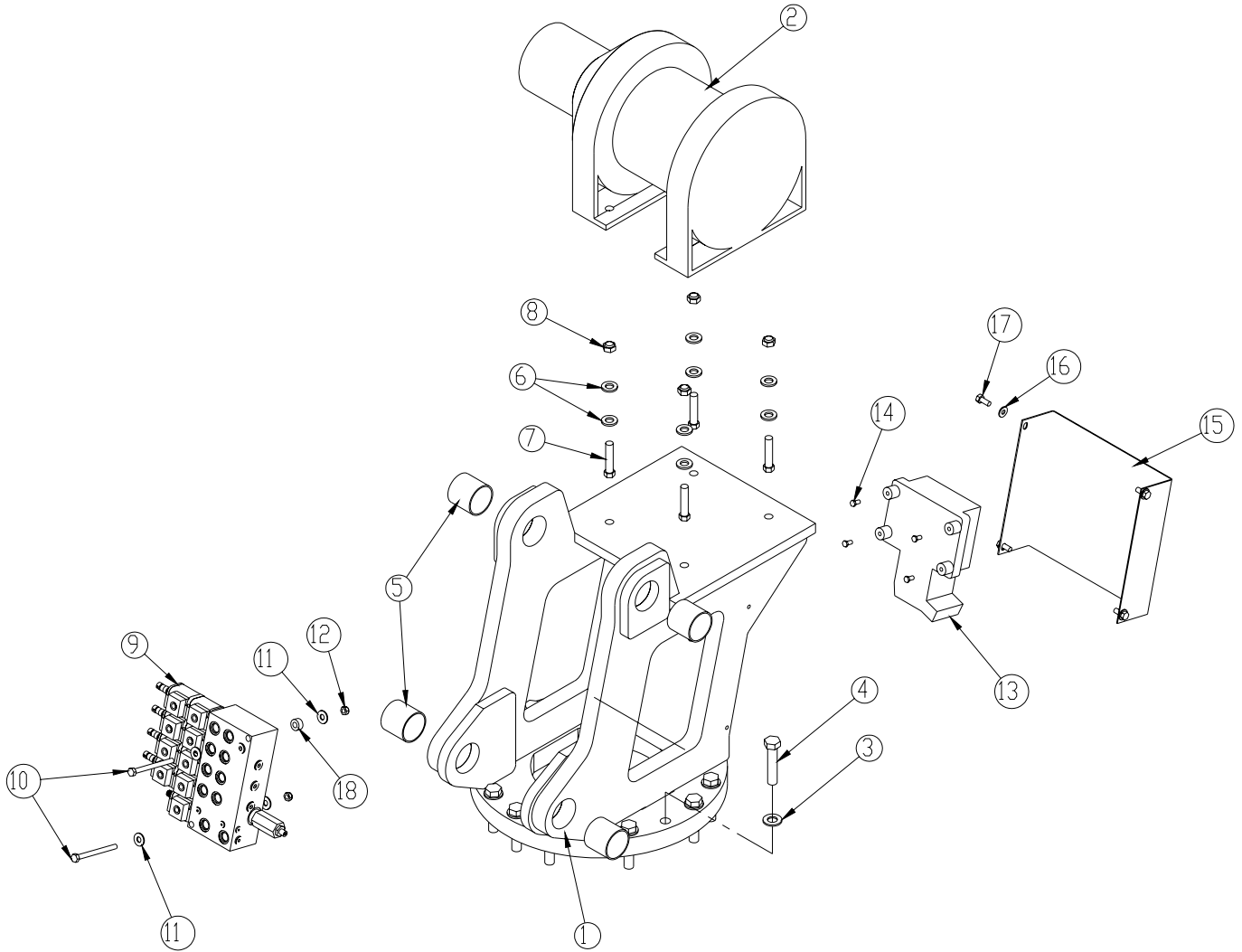

ITEM	PART	DESCRIPTION	QTY.	ITEM	PART	DESCRIPTION	QTY.
1	12967	MAST 9620 CRANE	1	10	24139	CAP SCR 0.31-18X3.75 HHGR5	2
2	12968	WINCH 5000 P5-CC-05-1	1	11	0343	WASHER 0.31 USS FLAT ZINC	4
3	C5902	WASHER 0.63 SAE FLAT YELLOW GR8	14	12	0342	NUT 0.31-18 HH NYLOC	2
4	D1034	CAP SCR 0.63-11 X 3.00 HHGR8 ZY	14	13	11847	RADIO RECEIVER	1
5	4381	BUSHING 32DXR32 2.00X2.00 GARLOCK	4	14	10976	CAP SCR 6MMX12MM HHGR8	4
6	D0790	WASHER 0.50 FLAT GR8	8	15	13391	COVER 9620 MAST	1
7	10662	CAP SCR 0.50-13X2.50 HHGR8 ZY	4	16	0340	WASHER 0.25 FLAT	4
8	C6106	NUT 0.50-13 HHGR5 NYLOC	4	17	0420	CAP SCR 0.31-18X0.75 HHGR5	4
9	24685	VB 4 SECT ELECT W/PROP STERLING8GPM	1	18	27813	COLLAR 0.38X0.69X0.38 UHMW	2

MAIN BOOM ASSEMBLY P/N 18029

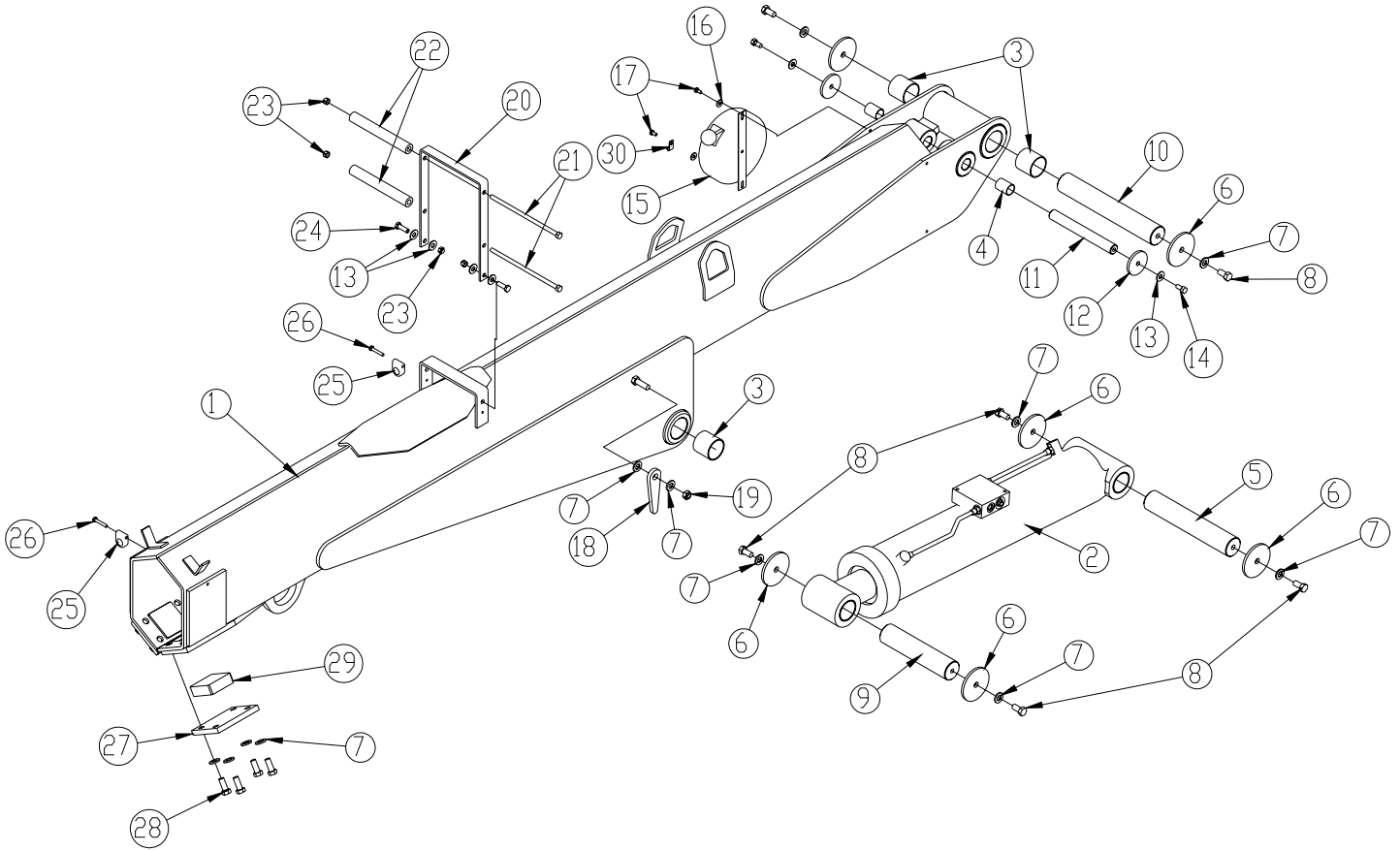

ITEM	PART	DESCRIPTION	QTY.	ITEM	PART	DESCRIPTION	QTY.
1	12884	BOOM INNER 9620	1	16	0340	WASHER 0.25 FLAT	2
2	24144	CYLINDER ASM 9620 INNER	1	17	0478	CAP SCR 0.25-20X0.50 HHGR5	2
3	4381	BUSHING 32DXR32 2.00X2.00 GARLOCK	4	18	D1194	PLATE ANGLE INDICATOR	2
4	0068	BUSHING QSI-1618-24	2	19	C6106	NUT 0.50-13 HHGR5 NYLOC	2
5	13363	PIN 2.00X11.19 D&T	1	20	13435	BRKT ROPE GUIDE 9620	1
6	8377	PIN CAP 0.56X3.50X.25	6	21	12168	CAP SCR 0.38-16X9.00 HHGR5	2
7	D0790	WASHER 0.50 FLAT GR8	18	22	27720	SPACER ROPE GUIDE 6620 UHMW	2
8	10172	CAP SCR 0.50-13X1.00 HHGR8 ZY	6	23	0347	NUT 0.38-16 HH NYLOC	4
9	9711	PIN 2.00X8.88 D&T	1	24	0335	CAP SCR 0.38-16X1.25 HHGR5	2
10	13364	PIN 2.00X12.69 D&T	1	25	0337	HOSE CLAMP LN 4190 PP	2
11	9712	PIN 1.00X8.38 D&T	1	26	0220	CAP SCR 0.25-20 X 1.50 HHGR5	2
12	7403	PIN CAP 0.44X2.50X.252	2	27	13398	PLATE WEAR PAD SUPPORT 9620	2
13	C6353	WASHER 0.38 FLAT GR8	6	28	10666	CAP SCR 0.50-13X1.25 HHGR8	8
14	9843	CAP SCR 0.38-16X0.75 HHGR8	2	29	13395	WEAR PAD 3.00X3.00X1.00 NYLATRON	2
15	11544	CORD REEL 6620	1	30	C5606	CLAMP 0.25 BLK VINYL	1

CYLINDER ASSEMBLY P/N 24144

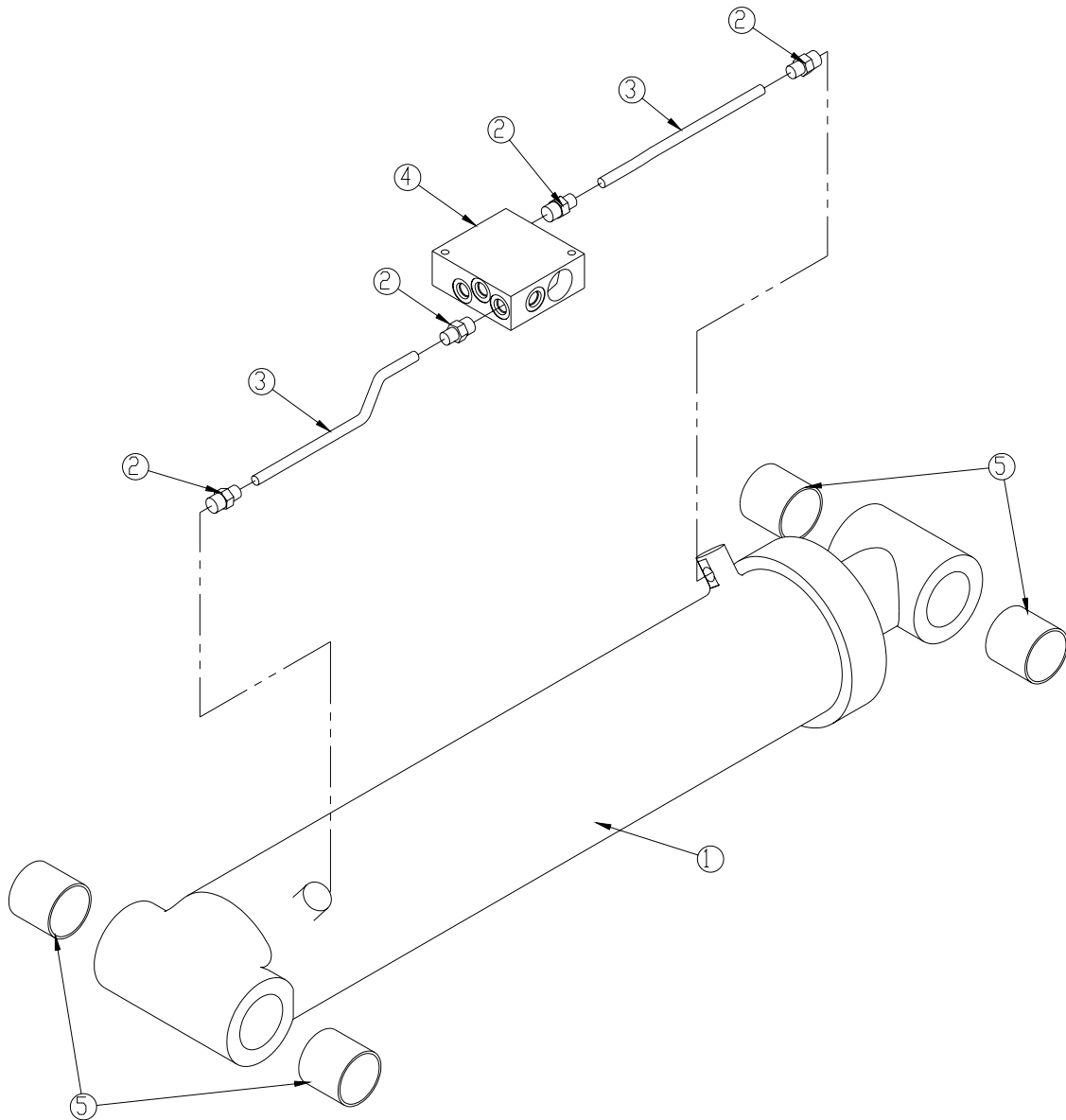

ITEM	PART	DESCRIPTION	QTY.
1	12970	CYLINDER INNER 9620 5.00X21.38	1
2	0279	FTG ADAPT 6-F5OLO-S	4
3	12158	TUBE ASM 0.38X8.88 MAIN CYL 6620	2
4	13080	MANIFOLD ASM 6620 INNER HOLDING	1
5	4381	BUSHING 32DXR32 2.00X2.00 GARLOCK	4

EXTENSION BOOM ASSEMBLY P/N 18233

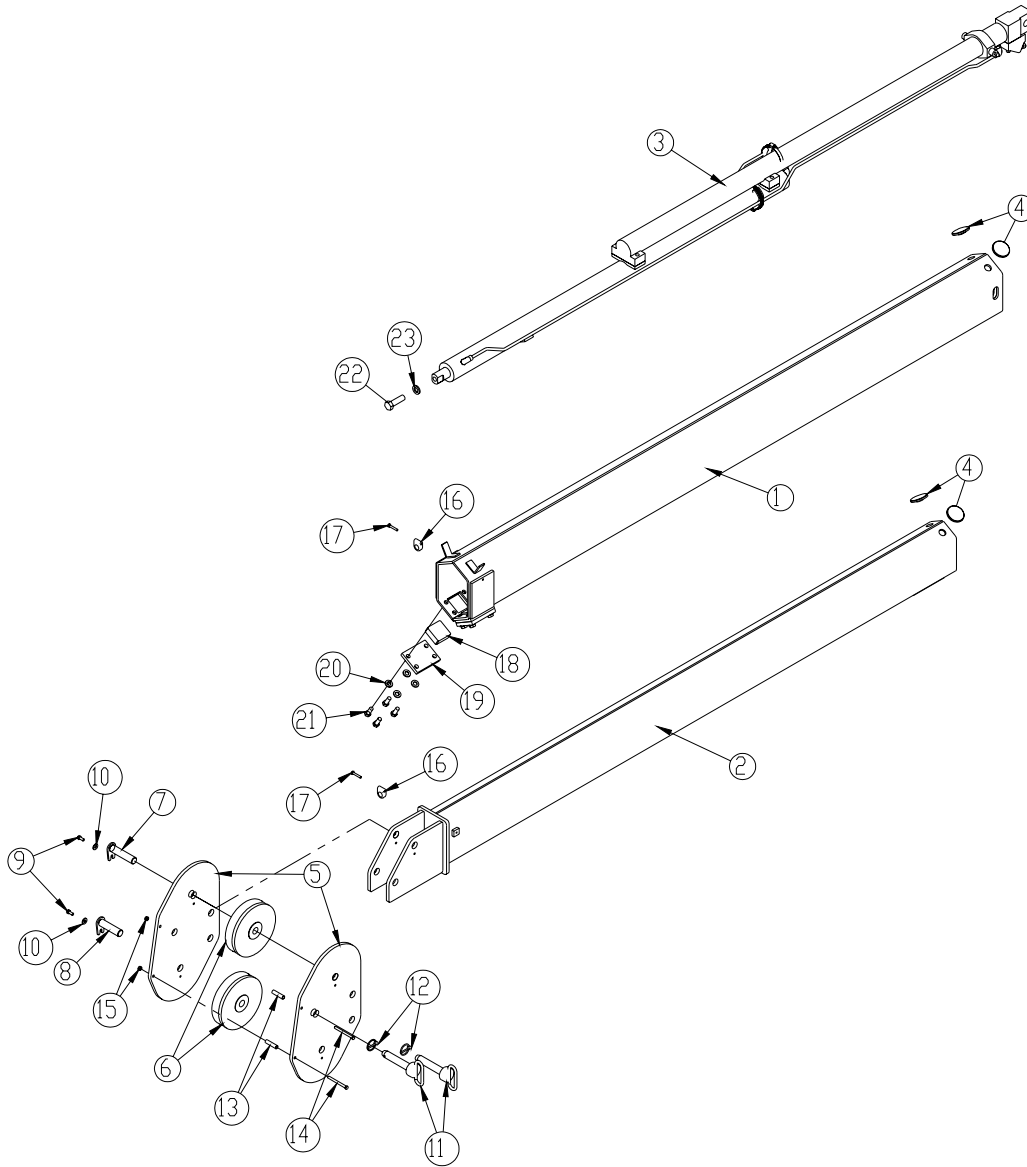

ITEM	PART	DESCRIPTION	QTY.	ITEM	PART	DESCRIPTION	QTY.
1	12885	EXT BOOM 9620 1ST	1	13	27719	SPACER BOOM TIP 6620 UHMW	2
2	15890	EXT BOOM 10620 2ND	1	14	0490	CAP SCR 0.31-18X3.50 HHGR5	2
3	28859	CYLINDER EXT ASM 9620 13980P	1	15	0342	NUT 0.31-18 HH NYLOC	2
4	9991	WEAR PAD 0.25X2.00 RND NYLATRON	4	16	0337	HOSE CLAMP LN 4190 PP	2
5	15998	PLATE SHEAVE MOUNTING 10620	2	17	0220	CAP SCR 0.25-20 X 1.50 HHGR5	2
6	15889	SHEAVE 10620 9.00DIA .44/1.94 THK	2	18	13396	WEAR PAD 2.50X2.50X1.00 NYLATRON	2
7	13400	PIN TEAR DROP 1.00X4.38	1	19	13397	PLATE 1ST EXT 9620 WEAR PAD	2
8	13399	PIN TEAR DROP 1.00X3.81	1	20	D0790	WASHER 0.50 FLAT GR8	8
9	0420	CAP SCR 0.31-18X0.75 HHGR5	2	21	10666	CAP SCR 0.50-13X1.25 HHGR8	8
10	0343	WASHER 0.31 USS FLAT ZINC	2	22	4974	CAP SCR 0.75-10X2.50 HHGR8 ZY	1
11	12824	PIN HITCH 1.00X4.50	2	23	C6219	WASHER 0.75 SAE FLAT YELLOW GR8	1
12	5753	PIN 0.19X1.56 LYNCH	2				

CYLINDER ASSEMBLY P/N 28859

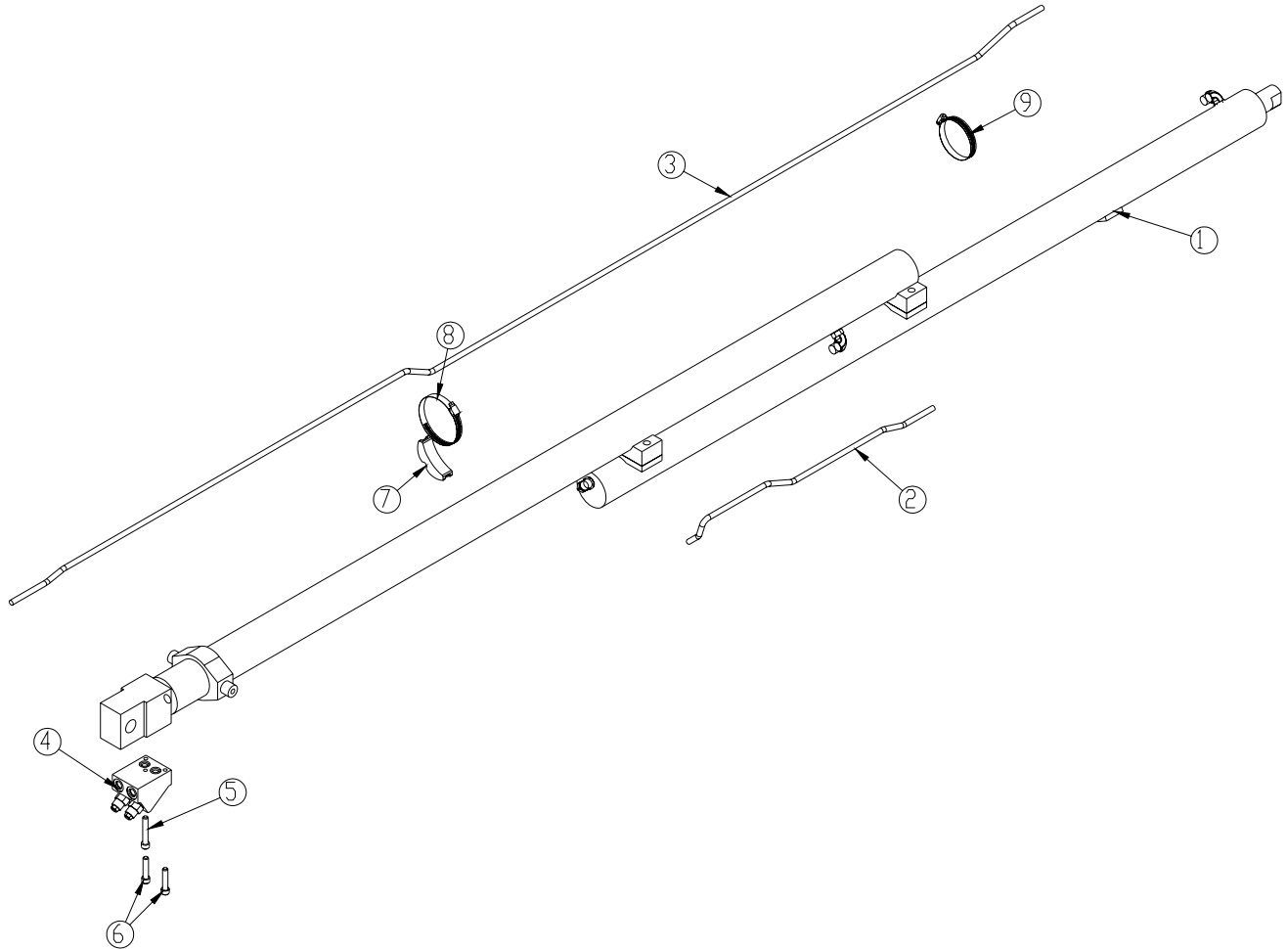

ITEM	PART	DESCRIPTION	QTY.
1	13980P	CYLINDER 13980 PAINTED	1
2	14442	TUBE ASM 0.38X23.25 EXT CYL 6620	1
3	14443	TUBE ASM 0.38X102.25 EXT CYL 6620	1
4	14115	MANIFOLD ASM 6620 EXT CBBB-LJN-XVN	1
5	14601	CAP SCR 0.38-16X2.25 SH ZC	1
6	11882	CAP SCR 0.38-16X1.75 SH ZC	2
7	18701	CLAMP PORT TUBE ZR518	1
8	24729	HOSE CLAMP #52 3.00 - 3.75	1
9	29143	HOSE CLAMP #40 SS	1

CABLE AND HOOK ASSEMBLY P/N 18234

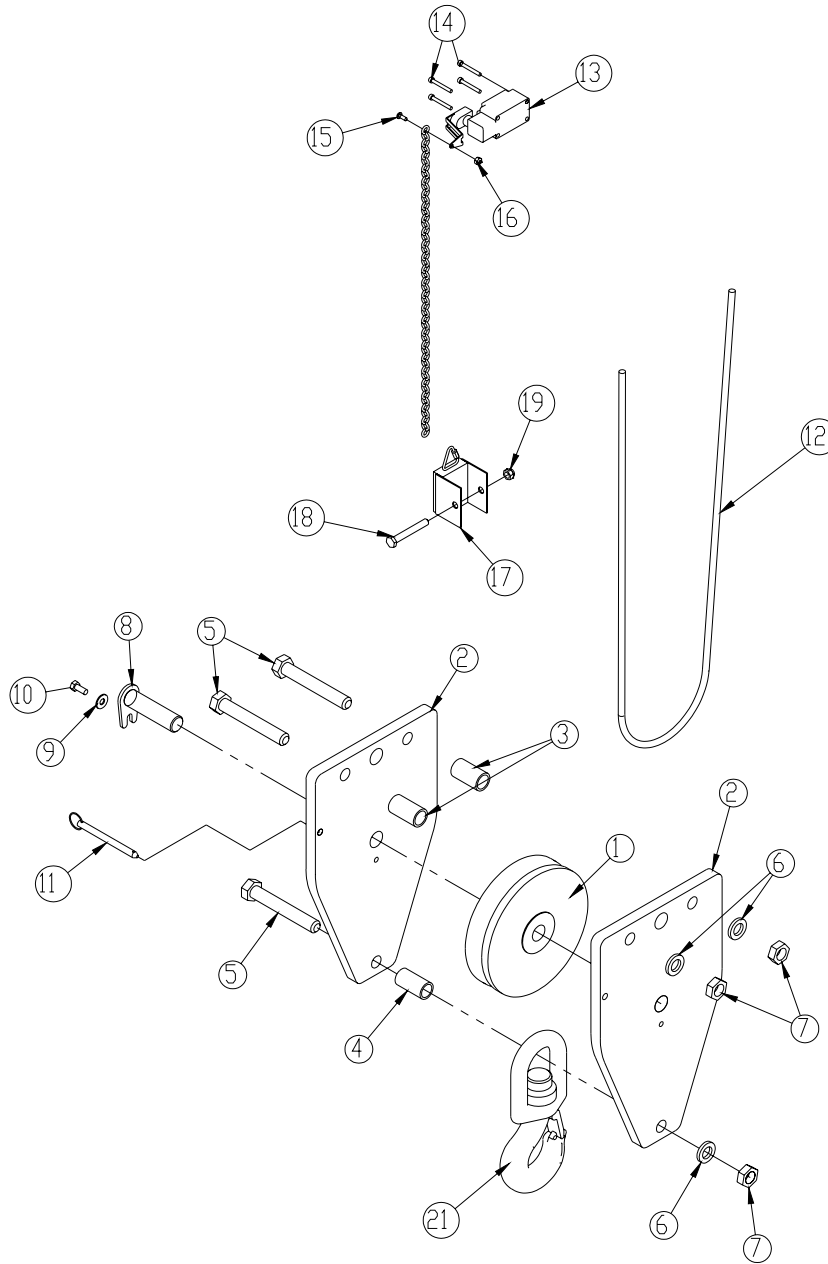

ITEM	PART	DESCRIPTION	QTY.	ITEM	PART	DESCRIPTION	QTY.
1	15889	SHEAVE 10620 9.00DIA .44/1.94 THK	1	12	15997	WIRE ROPE 7/16 6X19 IWRC-DGXIP100FT	1
2	16000	PLATE 10620 SNATCH BLOCK	2	13	11938	SWITCH LIMIT A2B FURNAS 3SE3170	1
3	27811	SPACER 9620 SNATCH BLOCK UHMW	2	14	12177	CAP SCR #10-24 X 1.50 SHGR5	4
4	13394	SPACER 9620 SNATCH BLOCK	1	15	D1711	CAP SCR #10-24X0.50 BTNHD SS	1
5	C1030	CAP SCR 0.75-10X5.00 HHGR8	3	16	C4956	NUT #10-24 HH NYLOC SS	1
6	C6219	WASHER 0.75 SAE FLAT YELLOW GR8	3	17	19994	WEIGHT 3315 ATB	1
7	0538	NUT 0.75 HHGR8 NYLOC	3	18	0530	CAP SCR 0.38-16X2.75 HHGR5	1
8	13399	PIN TEAR DROP 1.00X3.81	1	19	0347	NUT 0.38-16 HH NYLOC	1
9	0343	WASHER 0.31 USS FLAT ZINC	1	20	18454	CHAIN 0.105X21.50	1
10	0420	CAP SCR 0.31-18X0.75 HHGR5	1	21	25831	HOOK 5 TON SWIVEL CROSBY 1028623	1
11	13436	PIN .38X4.00 QUICK RELEASE	1				

WIRE ROPE / SHEAVE CONFIGURATIONS

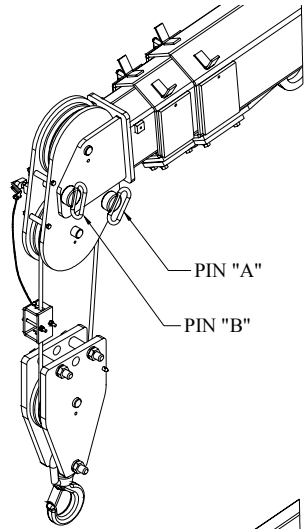

STANDARD 2 PART LINE
SHEAVE FLIPPED DOWN
CAPACITIES AS SHOWN ON
LOAD CHART

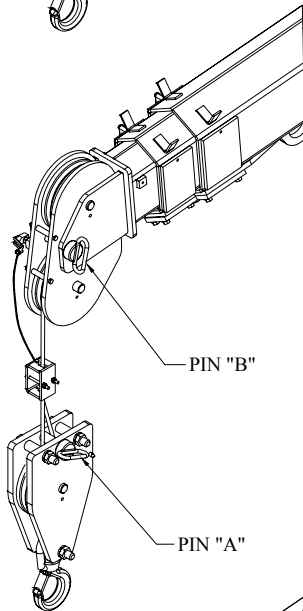

SINGLE PART LINE
SHEAVE FLIPPED DOWN
(MAXIMUM CAPACITY 4300#)

- 1.) REMOVE PIN A FROM BOOM TIP
- 2.) ROUTE WIRE ROPE THROUGH SNATCH BLOCK
- 3.) PIN WIRE ROPE TO SNATCH BLOCK AS SHOWN WITH PIN "A"

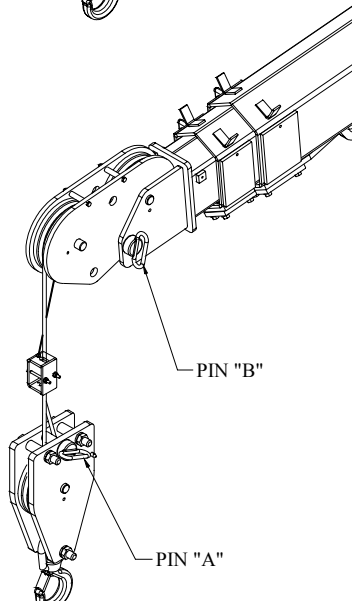

SINGLE PART LINE
SHEAVE FLIPPED UP
(MAXIMUM CAPACITY 4300#)

- 1.) REMOVE PIN B
- 2.) FLIP SHEAVE
- 3.) INSERT PIN B WITH SHEAVE IN UP POSITION

CONTROL KIT – 4 FUNCTION P/N 18932

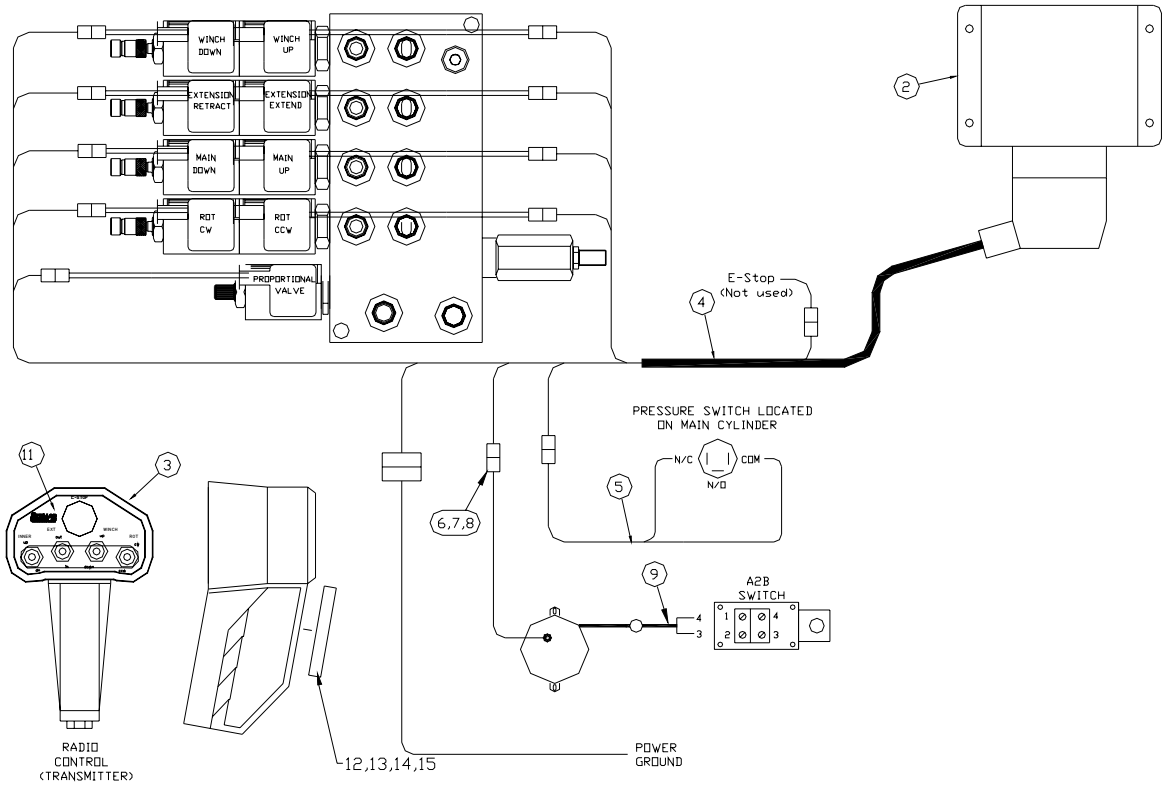

16	0333	NUT 0.25-20 HHGR5 NYLDC	1
14	C6021	CAP SCR 0.25-20X0.75 BTNHD SS	1
13	6832	DECAL MAGNET COVER-2.94DIA	1
12	6629	MAGNET 70# 2.80 DIA	1
11	18469	Decal - 4 function - Mech Cranes	1
10	16255	BATTERY CHARGER W/BTRY 110-36V	1
09	10965	CABLE GROMMET	1
08	10978	CONTACT M/TERM SHROUD	2
11	18469	Decal - 4 function - Mech Cranes	1
10	16255	BATTERY CHARGER W/BTRY 110-36V	1
09	10965	CABLE GROMMET	1
08	10978	CONTACT M/TERM SHROUD	2
07	8384	CABLE SEAL	2
06	9752	CONNECT 2 PIN SHROUD	1
05	13004	WIRE HARNESS PRESSURE SWITCH 6620	1
04	17744	WIRE HARNESS RADIO/VB	1
03	11833	TRANSMITTER - RADIO (PART OF 1)	RBP
02	11847	RECEIVER - RADIO (PART OF 1)	RBP
01	11832	RADIO CONTROLLER ASSEMBLY	1
ITEM	PART No.	DESCRIPTION	QTY

CONTROL KIT – 7 FUNCTION P/N 10701

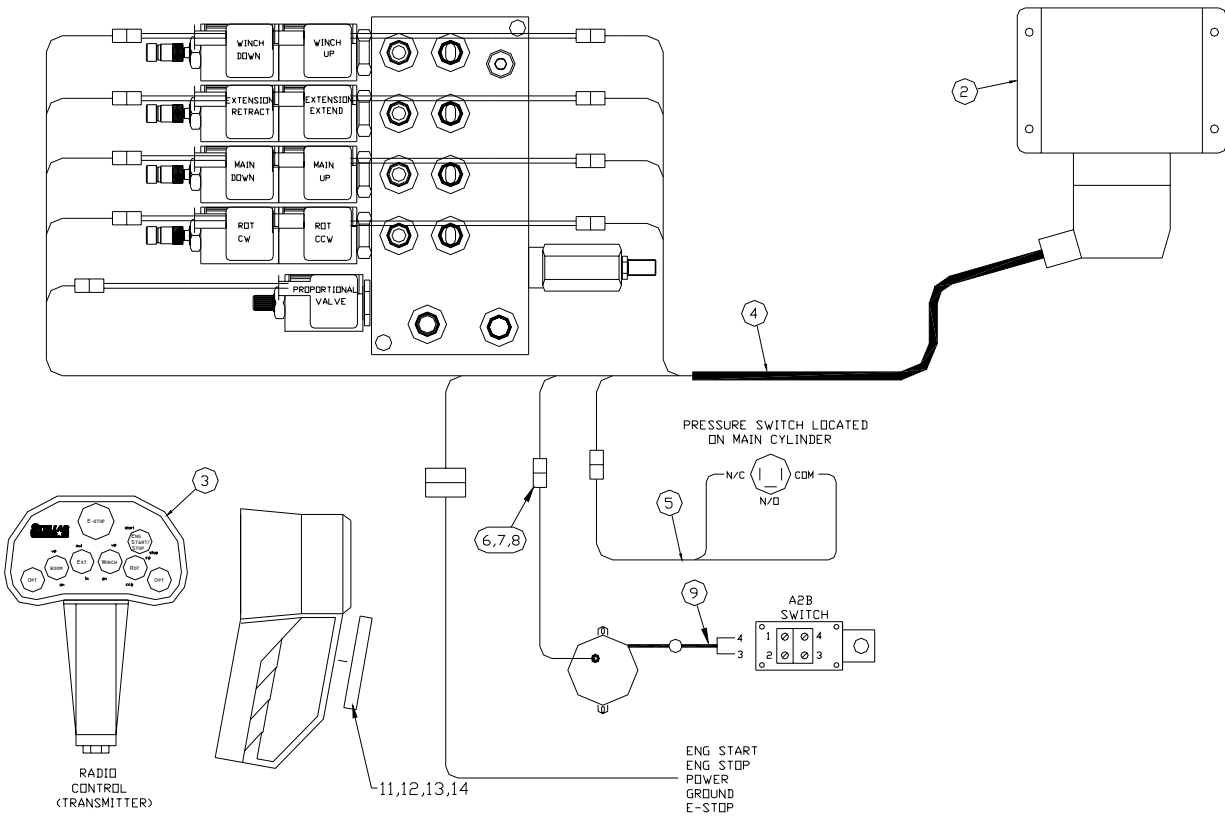

14	0933	NUT 0.25-20 HHGR5 NYLOC	1
13	C6021	CAP SCR 0.25-20X0.75 BTNHD SS	1
12	6832	DECAL MAGNET COVER-2.94DIA	1
11	6829	MAGNET 70# 2.80 DIA	1
10	18256	BATTERY CHARGER W/BTRY 110-3.6V	1
09	10965	CABLE GROMMET	1
08	10978	CONTACT M/TERM SHROUD	2
07	8384	CABLE SEAL	2
06	9752	CONNECT 2 PIN SHROUD	1
05	13004	WIRE HARNESS PRESSURE SWITCH 6620	1
04	12134	WIRE HARNESS RADIO/VB	1
03	11834	TRANSMITTER - RADIO (PART OF 1)	RBF
02	11847	RECEIVER - RADIO (PART OF 1)	REF
01	11835	RADIO CONTROLLER ASSEMBLY	1
ITEM	PART No.	DESCRIPTION	QTY

HYDRAULIC KIT P/N 13971

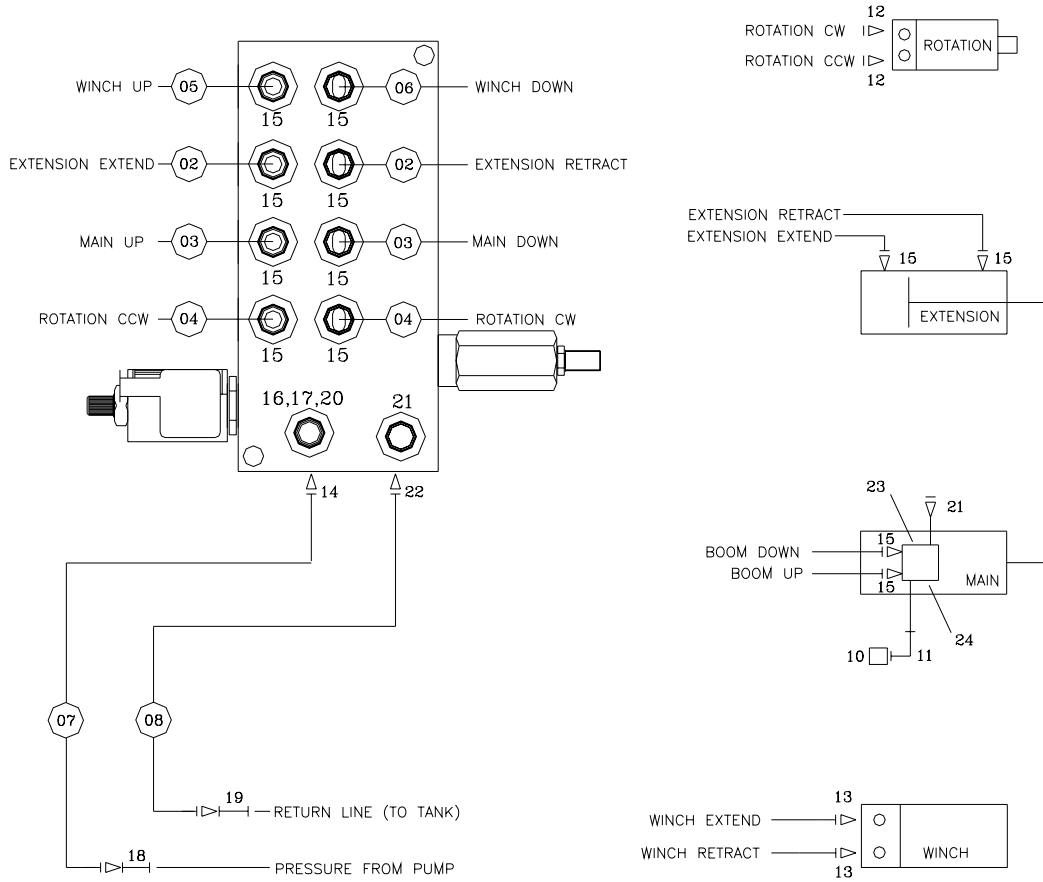

24	11991	VALVE C-BAL PLUG	REF
23	9803	VALVE C-BAL	REF
22	C1175	FTG ELL 8-V5OLO-S	1
21	C4961	PLUG STR HOLLOW HEX 0.38 6-HP50N	2
20	D1430	FTG ADAPT O-RING FMP 6-1/4 F50G-S	1
19	12172	FTG SWIVEL 0.50 FS/FS PS81 JMJM-8-8	1
18	12171	FTG SWIVEL 0.38 FS/FS PS81 JMJM-6-6	1
17	6397	GAUGE OIL LF 2.5" 0-5000 CBM	1
16	C5908	FTG 0.25 ML ELL	1
15	0279	FTG ADAPT 6 F5OLO-S	12
14	D1193	FTG ADAPT 6-V5OLO-S	1
13	7343	FTG O-RING FS 45 DEG 6-8 V5OLO	2
12	D1302	FTG ST TH ELB 90 DEG 6-10 C5OLO	2
11	3861	FTG ML FM O-RING 90 DEG	1
10	4587	SWITCH PRES OVERLD 744.6-S03R-3200N	1
09	.	.	.
08	25022	HOSE-HYD .50 X 5	1ref
07	25021	HOSE-HYD .38 X 6	1ref
06	13032	HOSE-HYD .38 X 15	1ref
05	13031	HOSE-HYD .38 X 14	1ref
04	13030	HOSE-HYD .38 X 39	2ref
03	13029	HOSE-HYD .38 X 22.50	2ref
02	13028	HOSE-HYD .38 X 17	2ref
01	13027	HOSE KIT,9620 CRANE (incl:2-11)	1
ITEM	PART No.	DESCRIPTION	QTY

INSTALLATION KIT P/N 13539

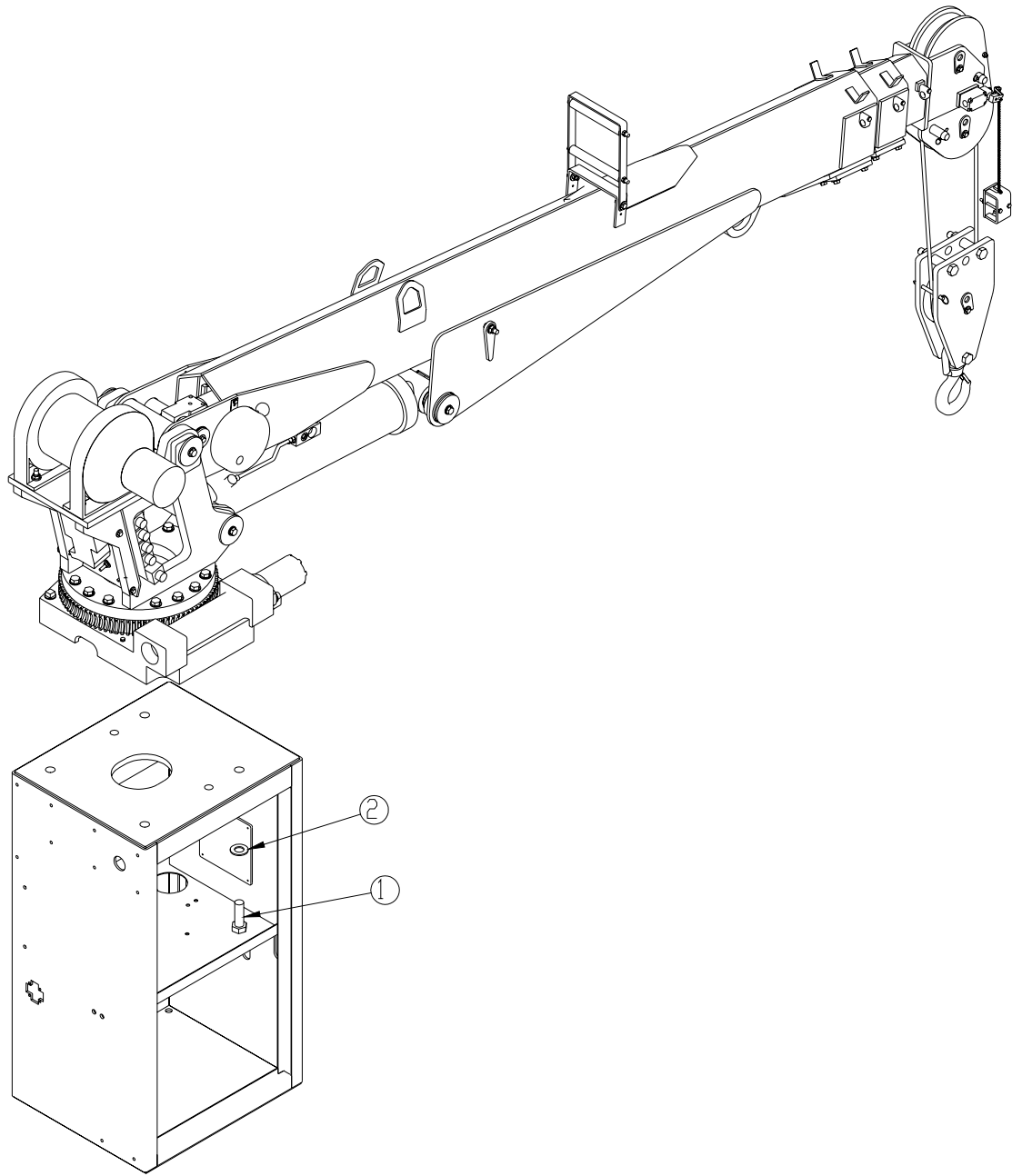

ITEM	PART	DESCRIPTION	QTY.
1	5199	CAP SCR 1.00X8X3.00 HHGR8 ZY	6
2	6538	WASHER 1.00 SAE FLAT YELLOW GR8	6

DECAL KIT P/N 13538

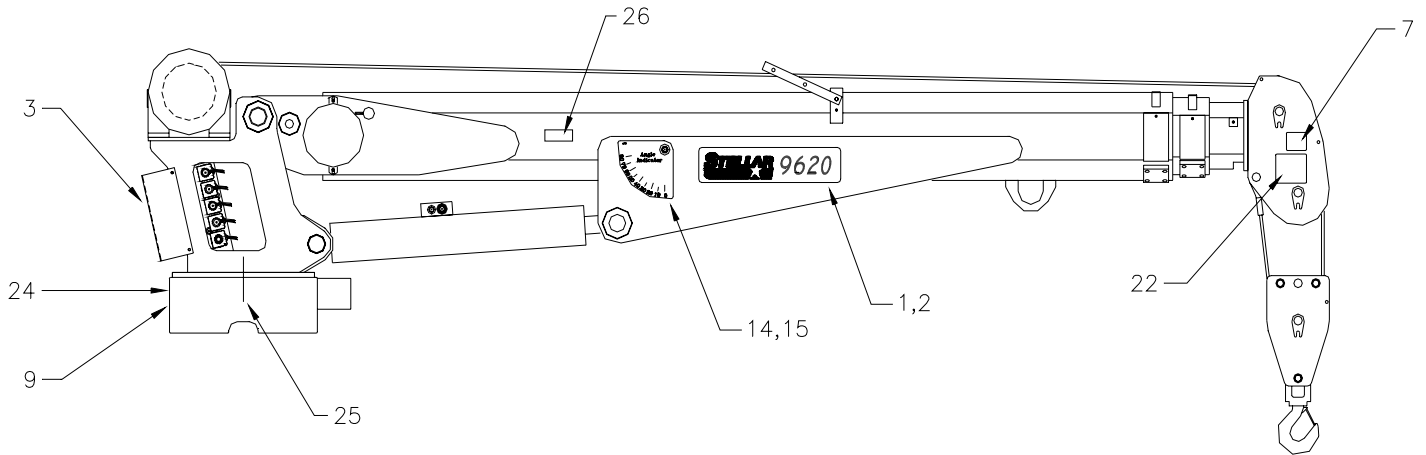

26	15172	DECAL ASME/ANSI B30.22/B30.5	1
25	15171	DECAL GREASE WORM DRIVE BEARINGS	1
24	4188	DECAL-ROTATION ALIGNMENT	1
*23	C4541	DECAL-CRANE STOWING	1
22	12300	DECAL-TWO BLOCKING	1
*21	4214	DECAL-SERVICE	1
*20	C0568	DECAL-DIESEL	2
*19	12452	DECAL MANUAL EXT	1
*18	C5911	DECAL-STELLAR 2x4.5	3
*17	C5910	DECAL-STELLAR 4x9.5	1
*16	12451	DECAL HOISTING PERSONNEL	1
15	D1197	DECAL-ANGLE INDICATOR LH	1
14	D1196	DECAL-ANGLE INDICATOR RH	1
*13	C1179	DECAL-ELECTROCUTION 4.5x7.5	2
*12	C5918	DECAL-DANGER MOVING O.R.	2
*11	C4795	DECAL-DANGER O.R.	2
*10	4190	DECAL-DANGER	1
09	9188	DECAL-ROTATE/GREASE	1
*08	4189	DECAL-DANGER	1
07	4186	DECAL-ELECTROCUTION 2x2.75	1
*06	C4544	DECAL-DANGER	1
*05	C4540	DECAL-DANGER	1
*04	C4545	DECAL-ELECTROCUTION 5x13	4
*03	13535	DECAL CAPACITY	2
02	13537	DECAL IDENTIFICATION CS	1
01	13536	DECAL IDENTIFICATION SS	1
ITEM	PART No.	DESCRIPTION	QTY

*USE THESE DECALS WITH BODY PACKAGE

STABILITY

Definition of **STABILITY** for the Stellar Telescopic Crane Products:

A truck is stable until the load cannot be lifted off the ground with the winch, without tipping over the truck.

Every Stellar crane installed must be tested for stability to determine the actual load capacity of the final truck package. The actual test data must be recorded and supplied with the truck at the time of in-service and should be kept with the truck at all times. The following procedure will test the truck package for stability and will provide a stability capacity chart. The load limit information shown on the stability capacity chart is formulated on 85% of tipping.

Set Up

- Locate the truck on a test course in position for loading and engage travel brakes.
- Set outriggers so that they make contact with firm, level footings.
- Operate the crane under partial load to assure operator proficiency and proper machine function.

Test Data for 9620 Crane

- Maximum Horizontal Reach – 249 inches (center of rotation to boom tip)
- Stability Test Weight – 3125#

Test Procedure

- Rotate the crane into zone 1 position.
- With the crane fully retracted and the boom horizontal, winch the test weight off the ground. Note: keep the weight within six inches of the ground at all times.
- Extend the boom outward until full extension has been reached or until the truck becomes unstable (again, use the winch to keep the weight within six inches of the ground).
- If the boom goes full extension without becoming unstable, the crane is termed stable for this zone and 100% can be written in the zone 1 data box.
- If the truck becomes unstable prior to going full extension - retract the boom until the truck becomes stable and measure the horizontal reach in this position (center of rotation to boom tip). This is the stable horizontal reach for this zone. Use the following formula to determine the percentage of rated capacity.
Stable horizontal reach divided by Maximum horizontal reach multiplied by 100 equals the percentage of rated capacity for this zone. Record this number in the data box for zone 1. This is the revised capacity due to stability for this zone.
- Repeat this procedure for each zone until the worksheet is completed.
- This is the revised CAPACITY based on STABILITY of this package.

STABILITY CHART

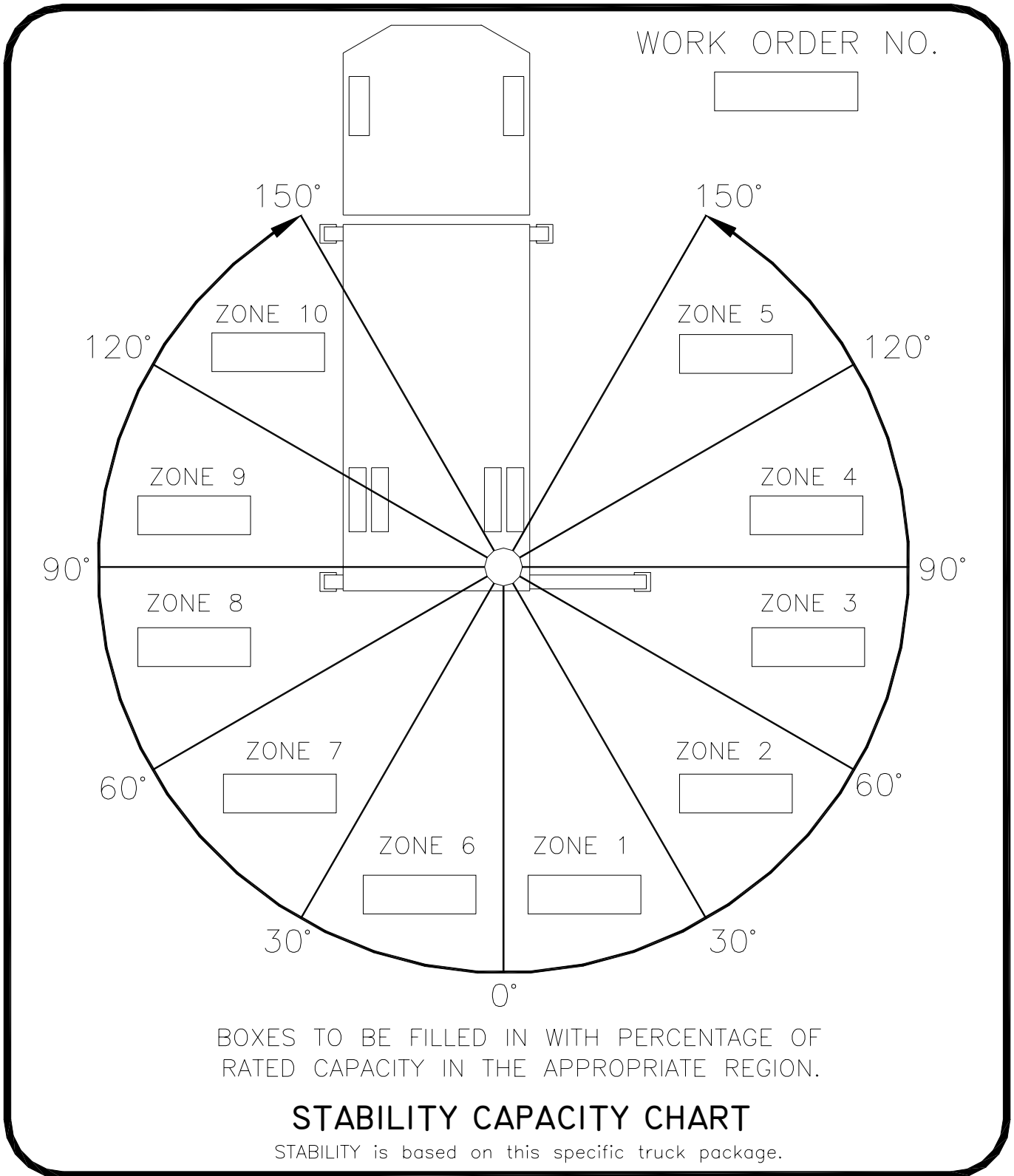

Limited Warranty Statement

for Stellar Tire Service Trucks, Truck-mounted Cranes, Truck-mounted Stellarc Welders & Truck-mounted Compressed Air Systems ONLY

Stellar Industries, Inc. (Stellar) warrants products designed and manufactured by Stellar to be free from defects in material and workmanship under proper use and maintenance. Products must be installed and operated in accordance with Stellar's written instructions and stated lifting capacities. The warranty period shall be Twelve (12) month warranty on all Stellar designed and fabricated parts, and Ninety (90) days repair labor.

The warranty period shall begin from the date recorded by Stellar as the in-service date. This date will be derived from the completed warranty registration card. In the event a warranty registration card is not received by Stellar, the factory ship date will be used. Stellar's obligation under this warranty is limited to, and the sole remedy for any such defect shall be, the repair and/or replacement (at Stellar's option) of the part and/or component in question. Stellar after-sales service personnel must be notified by telephone, fax, e-mail, or mail of any warranty-applicable damage within fourteen (14) days of its occurrence. If at all possible, Stellar will ship the replacement part within 24-hours of notification by the most economical, yet expedient, means possible. Expedited freight delivery will be at the expense of the owner.

Warranty claims must be submitted and shall be processed in accordance with Stellar's established warranty claim procedure. Stellar Service personnel must be contacted prior to any warranty claim. A return materials authorization (RMA) account number must be issued to the claiming party prior to the return of any warranty parts. Parts returned without prior authorization will not be recognized for warranty consideration. All damaged parts must be returned to Stellar freight prepaid; freight collect returns will be refused.

Warranty service will be performed by any Stellar new equipment distributor, or by any Stellar-recognized service center authorized to service the type of product involved, or at the Stellar factory. At the time of requesting warranty service, the owner must present evidence of date of delivery of the product. The owner shall be obligated to pay for any overtime labor requested of the servicing company by the owner, any field service call charges, and any towing and/or transportation charges associated with moving the equipment to the designated repair/service provider.

All obligations of Stellar and its authorized dealers and service providers shall be voided if someone other than an authorized Stellar dealer provides other than routine maintenance service without prior written approval from Stellar. In the case repair work is performed on the Stellar-manufactured product, original Stellar parts must be used to keep the warranty in force. The warranty may also be voided if the product is modified or altered in any way not approved, in writing, by Stellar engineering.

The owner/operator is responsible for furnishing proof of the date of original purchase of the Stellar product in question. Warranty registration is the ultimate responsibility of the owner and may be accomplished by the completion and return of the Stellar product registration card provided with the product. If the owner is unsure of registration, he is encouraged to contact Stellar at the address below to confirm registration of the product in question. This warranty covers only defective material and workmanship. It does not cover depreciation or damage caused by normal wear and tear, accident, mishap, untrained operators, or improper or unintended use. The owner has the obligation of performing routine care and maintenance duties as stated in Stellar's written instructions, recommendations, and specifications. Any damage resulting from owner/operator failure to perform such duties shall void the coverage of this warranty. The cost of labor and supplies associated with routine maintenance will be paid by the owner.

The only remedies the owner has in connection with the breach or performance of any warranty on the Stellar product specified are those set above. In no event will Stellar, the Stellar distributor/dealer, or any company affiliated with Stellar be liable for business interruptions, costs of delay, or for any special, indirect, incidental, or consequential costs or damages. Such costs may include, but are not limited to, loss of time, loss of revenue, loss of use, wages, salaries, commissions, lodging, meals, towing, hydraulic fluid, or any other incidental cost.

All products purchased by Stellar from outside vendors shall be covered by the warranty offered by that respective manufacturer only. Stellar does not participate in, or obligate itself to, any such warranty.

Hydraulic cylinders used in Stellar products are subject to the same warranty provisions stated above. Should a cylinder defect develop within the above stated warranty period, notify Stellar immediately. Stellar will ship, freight prepaid, by the most effective, expedient, means a new or re-manufactured cylinder of the same size and type. An authorization for return of the original part will be issued at the time the order is placed. The defective cylinder is to be returned to Stellar freight prepaid by the owner. Cylinders returned freight collect will be refused. Should the defective cylinder not be returned within 30 days of shipping the replacement cylinder, the owner is responsible to pay Stellar the full purchase price of the replacement part.

Stellar reserves the right to make changes in design or improvement upon its products without imposing upon itself the same upon its products theretofore manufactured.

This warranty will apply to all Stellar Tire Service Trucks, Truck-mounted Cranes, Truck-mounted Stellarc Welders & Truck-mounted Compressed Air Systems shipped from Stellar's factory after January 1, 1997. The warranty is for the use of the original owner only and is not transferable without prior written permission from Stellar.

THIS WARRANTY IS EXPRESSLY IN LIEU OF ANY OTHER WARRANTIES, EXPRESS OR IMPLIED, INCLUDING ANY WARRANTY OF MERCHANTABILITY OR FITNESS FOR A PARTICULAR PURPOSE. REMEDIES UNDER THIS WARRANTY ARE LIMITED TO THE PROVISION OF MATERIAL AND SERVICES, AS SPECIFIED HEREIN. STELLAR INDUSTRIES, INC. IS NOT RESPONSIBLE FOR INCIDENTAL OR CONSEQUENTIAL DAMAGES.

Stellar Industries, Inc. • 280 West Third Street • Garner, Iowa 50438 • U.S.A.

E-Mail • sales@stellar-industries.com

Telephone: 800/321-3741; 641/923-3741 • Fax: 641/923-2812; 641/923-2811

Revised 10/05/2000