

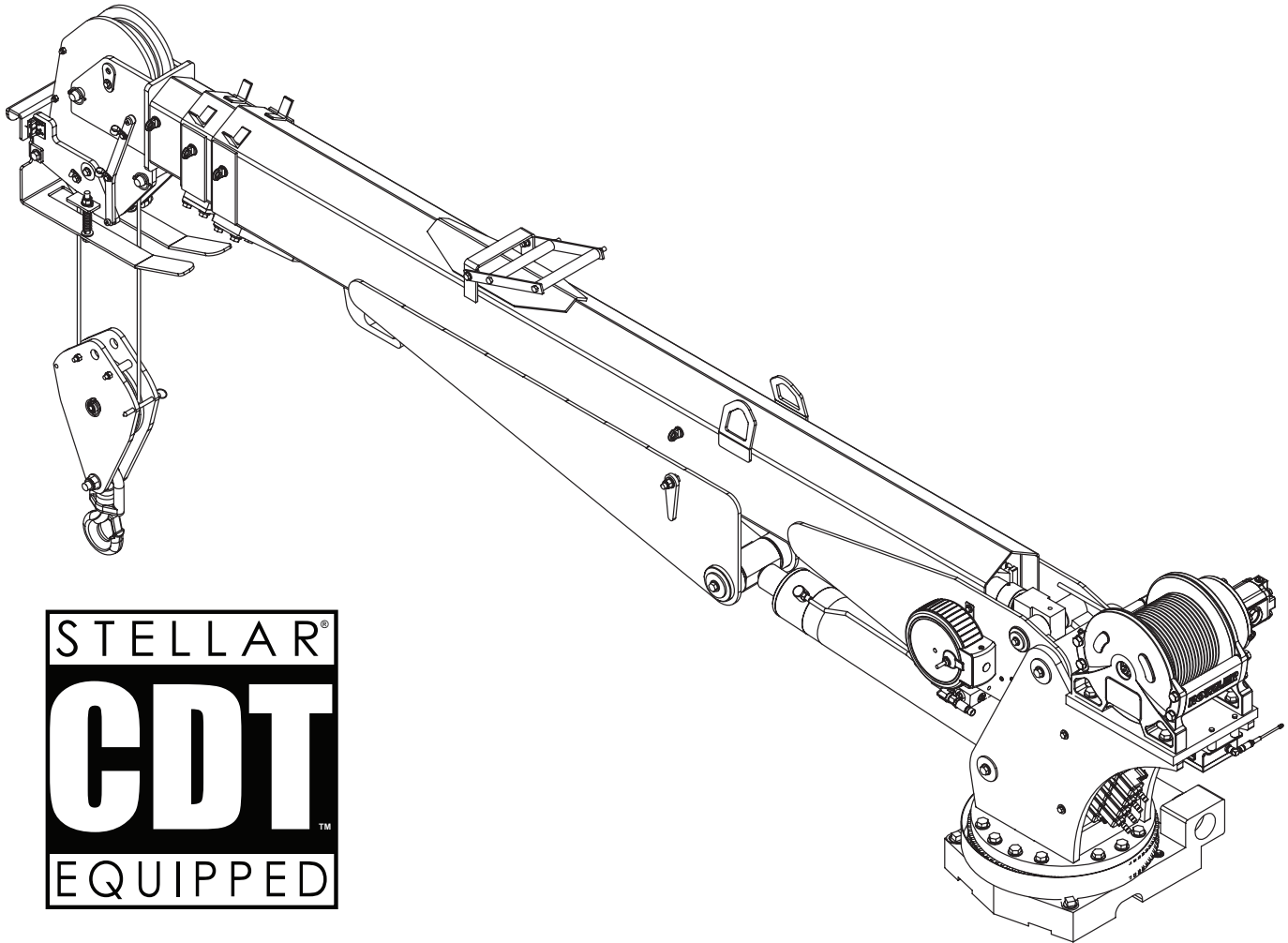

# Model 7621 Telescopic Crane Owner's Manual

Installation • Assembly Drawings • Parts



Notice: A copy of this manual must remain with the equipment at all times.  
For a printable download copy, please visit: [www.stellarindustries.com](http://www.stellarindustries.com)

**Stellar Industries, Inc.**

**190 State Street**

**PO Box 169**

**Garner, IA 50438**

**800-321-3741**

**Fax: 641-923-2811**

**[www.stellarindustries.com](http://www.stellarindustries.com)**

# Model 7621 Manual Revisions

Date of Revision	Section Revised	Description of Revision

**Serial Tag  
Location**

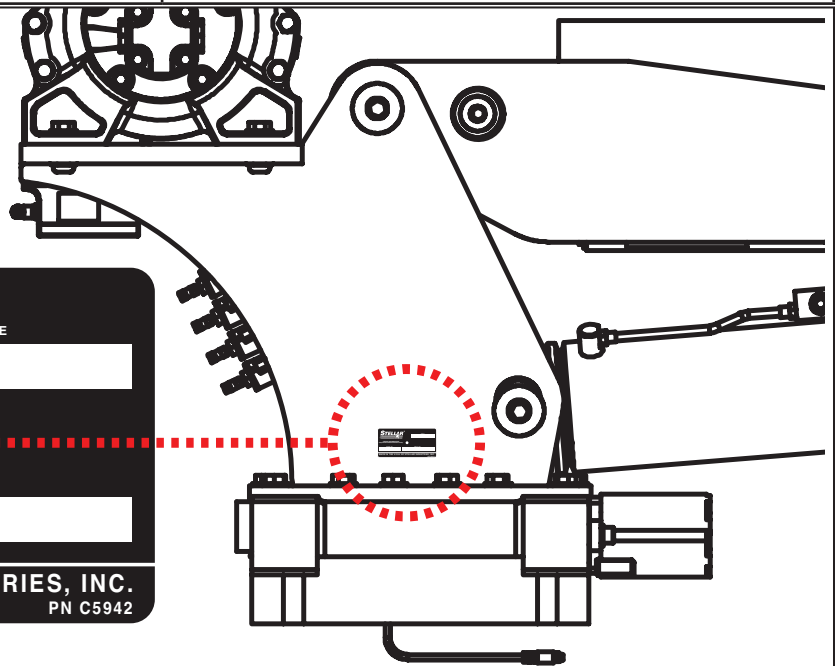
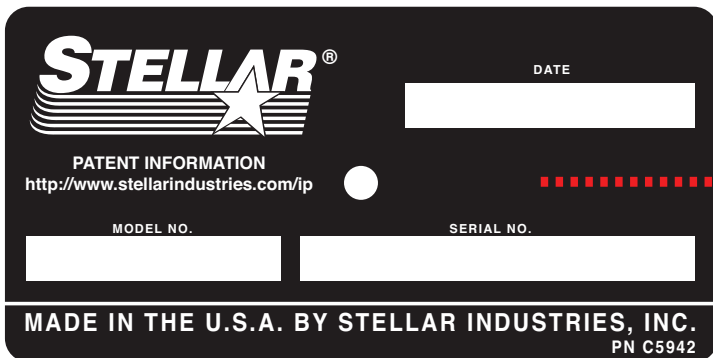

# Table of Contents

---

Introduction .....	iv
<b>Chapter 1 - Specifications.....</b>	<b>1</b>
Model 7621 Specifications .....	1
Capacity Chart - Decal PN 72801 .....	2
Dimensional Drawing 1 .....	3
Dimensional Drawing 2.....	4
<b>Chapter 2 - Installation .....</b>	<b>5</b>
General Installation.....	5
Installer Notice .....	5
Torque Data Chart.....	6
Installation Overview .....	7
Control Kit - PN 73249 .....	8
Control Kit (Non-Boost) - PN 73252 .....	9
Hydraulic Kit - PN 72758.....	10
Valve Bank - PN 52265.....	11
Hydraulic Installation.....	12
Winch Case Drain Installation.....	13
Hydraulic System .....	14
Face Seal/O-Ring Size Chart .....	15
Stability Procedure.....	16
Decal Placement - PN 72800.....	18
<b>Chapter 3 - Assembly Drawings .....</b>	<b>19</b>
Base Assembly - PN 50364.....	19
Gear Bearing - PN 47869 .....	20
Mast Assembly - PN 72789.....	21
Winch - PN 63516.....	22
Main Boom Assembly - PN 72790 .....	23
Extension Boom Assembly - PN 71056.....	24
Main Cylinder Assembly (Before 11/14/14) - PN 72756.....	25
Main Cylinder Assembly (As of 11/14/14) - PN 71461.....	26
Extension Cylinder Assembly - PN 49316.....	27
Cable & Hook Assembly - PN 56266 .....	28
<b>Chapter 4 - Replacement Parts .....</b>	<b>29</b>

# Introduction

A copy of this manual is provided with every crane and can be found in the hard plastic manual case that is installed on the chassis. A copy of this manual shall remain with the crane at all times.

Throughout the manual, three signal words will be used to bring attention to important items:

## **NOTICE**

A NOTICE signal word indicates a practice not related to physical injury.

## **⚠ WARNING**

A WARNING signal word indicates a hazardous situation which, if not avoided, could result in death or serious injury.

## **⚠ DANGER**

A DANGER signal word indicates a hazardous situation which, if not avoided, will result in death or serious injury.

Information contained within this manual does not cover operation, maintenance, or troubleshooting. Please refer to the General Light Duty Crane Manual for details on these items.

This manual is not binding. Stellar Industries, Inc. reserves the right to change, at any time, any or all of the items, components, and parts deemed necessary for product improvement or commercial/production purposes. This right is kept with no requirement or obligation for immediate mandatory updating of this manual.

In closing:

If more information is required or technical assistance is needed, or if you feel that any part of this manual is unclear or incorrect, please contact the Stellar Customer Service Department by phone at 800-321-3741 or email at [service@stellarindustries.com](mailto:service@stellarindustries.com).

**For Technical Questions, Information, Parts, or Warranty, Call Toll-Free at  
800-321-3741**

Hours: Monday - Friday, 8:00 a.m. - 5:00 p.m. CST

Or email at the following addresses:

**Technical Questions, and Information**

[service@stellarindustries.com](mailto:service@stellarindustries.com)

**Order Parts**

[parts@stellarindustries.com](mailto:parts@stellarindustries.com)

**Warranty Information**

[warranty@stellarindustries.com](mailto:warranty@stellarindustries.com)



# Capacity Chart - Decal PN 72801

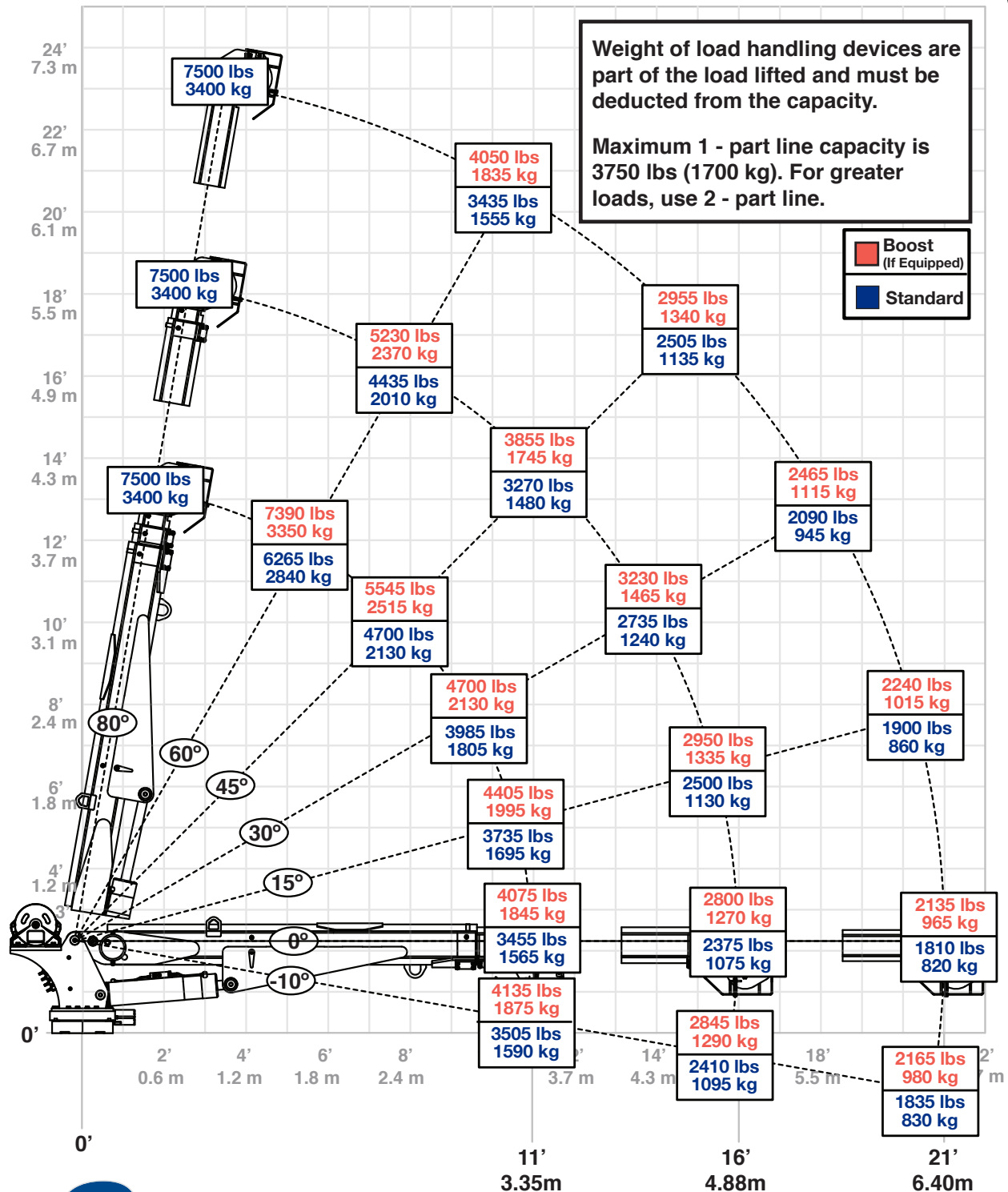

PN 72801

# Dimensional Drawing 1

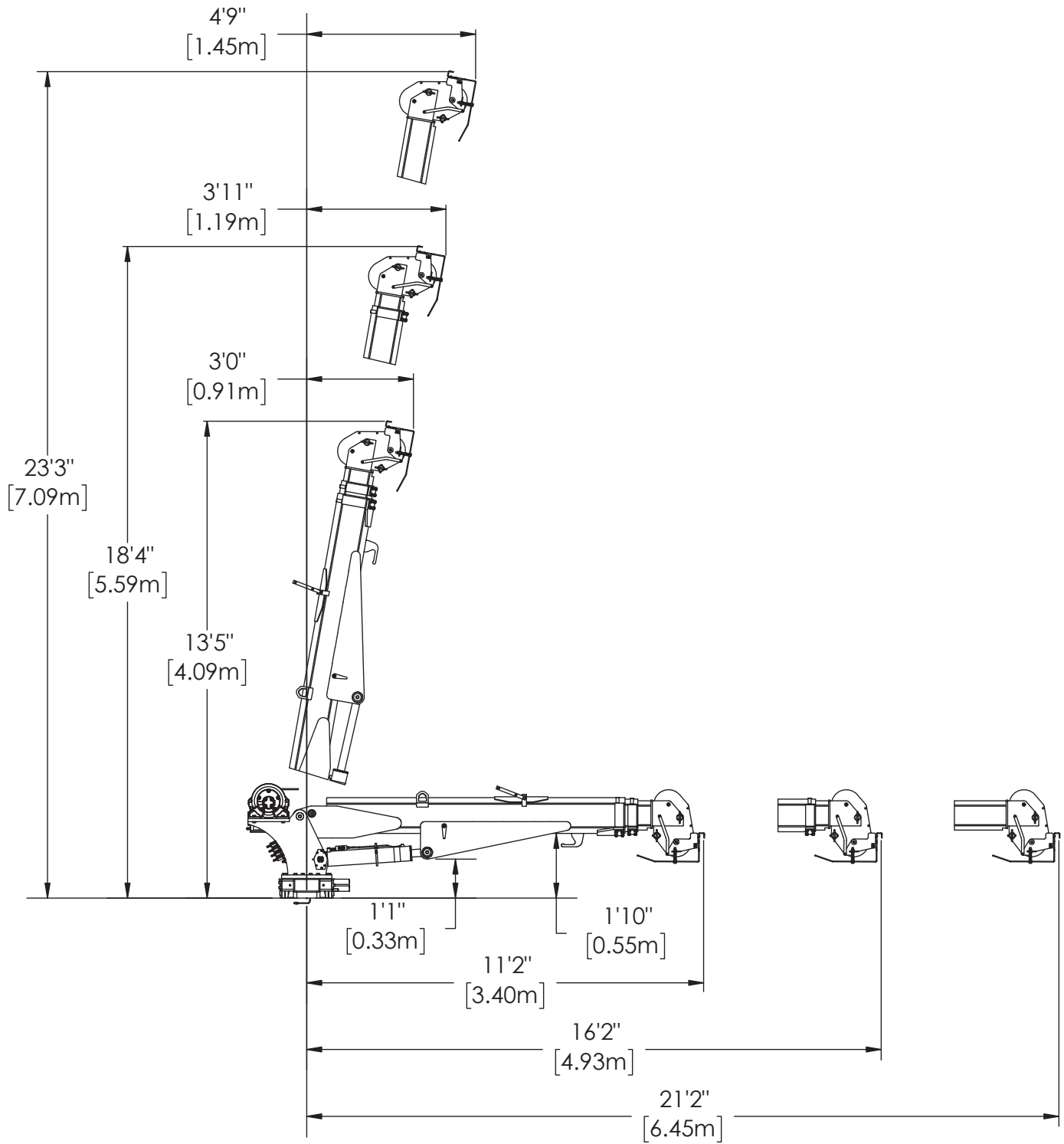

# Dimensional Drawing 2

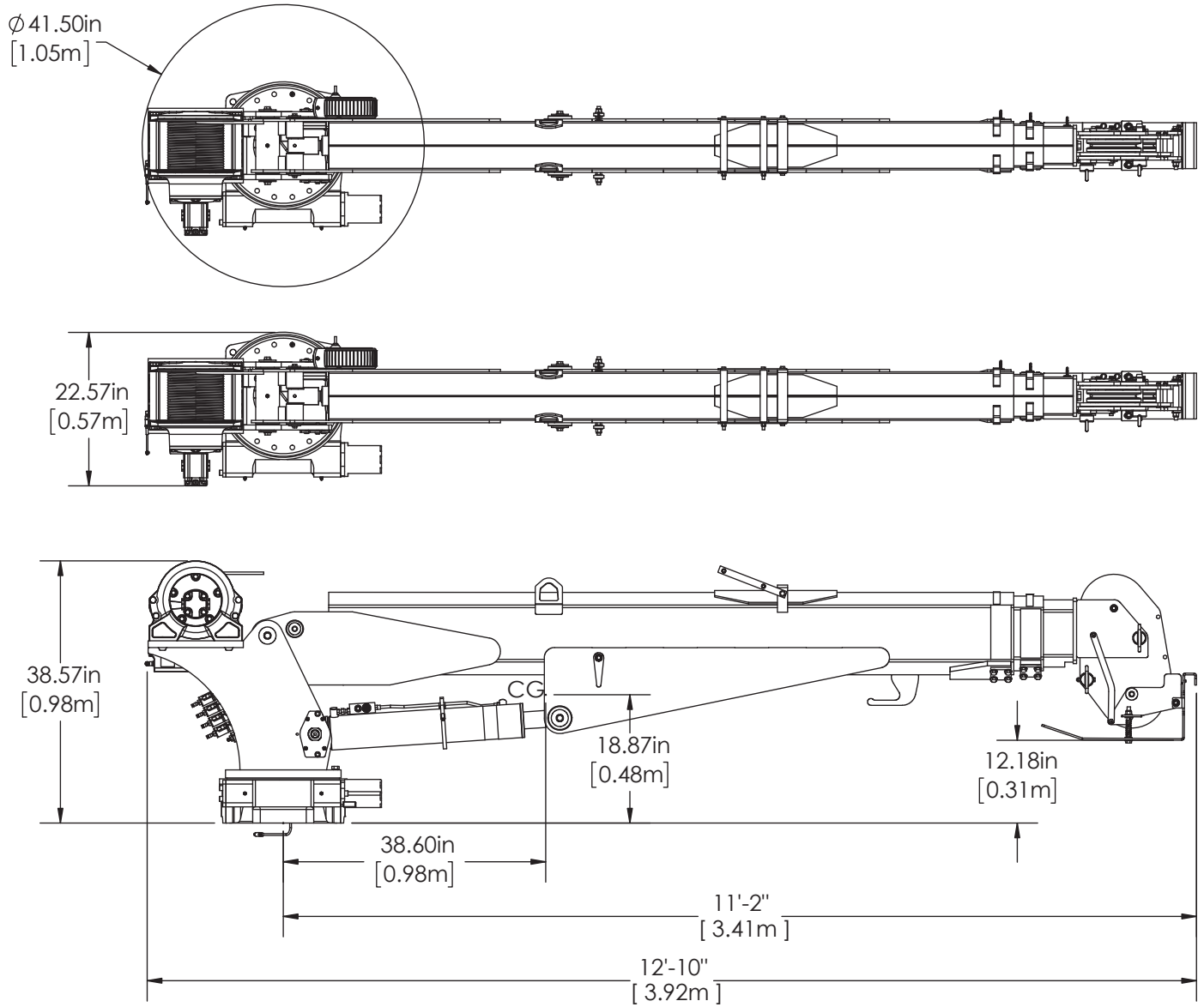



# Chapter 2 - Installation

## General Installation

This chapter is designed to serve as a general guide for the installation of a Stellar 7621 Crane on a Stellar Service Body. Each installation is considered unique so certain portions of this chapter may or may not apply to your direct application. If a question should arise during the installation process, please contact Stellar Customer Service at (800) 321 3741.

This crane is designed for use with a Stellar Service Body installed on a vehicle that meets the minimum chassis requirements of the crane. It is the installer's responsibility to assure that the crane is mounted on a platform that will support the maximum crane rating of this crane.

**⚠ WARNING** Do not install this crane on a body not capable of handling the loads imposed on it. Failure to do so may result in serious injury or death.

**NOTICE** When installing welder units to the service bodies, it is highly recommended that a surge protector is installed on the chassis batteries to protect the crane radio receiver, wiring and other electronic devices from an unexpected electrical spike or surge. Failure to do so could result in extensive damage to the service body and crane electrical circuit.

## Installer Notice

According to Federal Law (49 cfr part 571), each final-stage manufacturer shall complete the vehicle in such a manner that it conforms to the standards in effect on the date of manufacture of the incomplete vehicle, the date of final completion, or a date between those two dates. This requirement shall, however, be superseded by any conflicting provisions of a standard that applies by its terms to vehicles manufactured in two or more stages.

Therefore, the installer of Stellar® Cranes and Bodies is considered one of the manufacturers of the vehicle. As such a manufacturer, the installer is responsible for compliance with all applicable federal and state regulations. They are required to certify that the vehicle is in compliance with the Federal Motor Vehicle Safety Standards and other regulations issued under the National Traffic and Motor Vehicle Safety Act.

Please reference the Code of Federal Regulations, title 49 - Transportation, Volume 5 (400-999), for further information, or visit <http://www.gpoaccess.gov/nara/index.html> for the full text of Code of Federal Regulations.

## Torque Data Chart

When using the torque data in the chart, the following rules should be observed:

- Bolt manufacturer's particular specifications should be consulted when provided.

- Flat washers of equal strength must be used.

- All torque measurements are given in foot-pounds. To convert to inch-pounds, multiply by 12.

- Torque values specified are for bolts with residual oils or no special lubricants applied. If special lubricants of high stress ability, such as Never-Seez compound graphite and oil, molybdenum disulphite, colloidal copper or white lead are applied, multiply the torque values in the charts by the factor .90. The use of Loctite does not affect the torque values listed above.

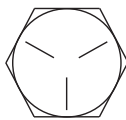
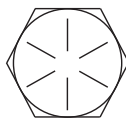
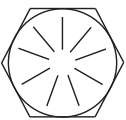
		GRADE 5		GRADE 8		GRADE 9
						
Size (DIA-TPI)	Bolt DIA (Inches)	Plain (Ft-Lb)	Plated (Ft-Lb)	Plain (Ft-Lb)	Plated (Ft-Lb)	Plated (Ft-Lb)
5/16-18	0.3125	17	13	25	18	22
3/8-16	0.3750	31	23	44	33	39
7/16-14	0.4375	49	37	70	52	63
1/2-13	0.5000	75	57	105	80	96
9/16-12	0.5625	110	82	155	115	139
5/8-11	0.6250	150	115	220	160	192
3/4-10	0.7500	265	200	375	280	340
7/8-9	0.8750	395	295	605	455	549
1-8	1.000	590	445	910	680	823
1 1/8-7	1.1250	795	595	1290	965	1167
1 1/4-7	1.2500	1120	840	1815	1360	1646
1 3/8-6	1.3750	1470	1100	2380	1780	2158
1 1/2-6	1.500	1950	1460	3160	2370	2865

- Torque values for socket-head capscrews are the same as for Grade 8 capscrews.
- Do not use these values if a different torque value or tightening procedure is given for a specific application. Torque values listed are for general use only. Check tightness of fasteners periodically.
- Shear bolts are designed to fail under predetermined loads. Always replace shear bolts with identical grade.
- Fasteners should be replaced with the same or higher grade. If higher grade fasteners are used, these should only be tightened to the strength of the original.
- Tighten plastic insert or crimped steel-type lock nuts to approximately 110 percent of the dry torque values shown in the chart below, applied to the nut, not to the bolt head. Tighten toothed or serrated-type lock nuts to the full torque value. *Note: "Lubricated" means coated with a lubricant such as engine oil, or fasteners with phosphate and oil coatings. "Dry" means plain or zinc plated without lubrication. Tighten lubricated bolts to approximately 80% of dry bolts.*

## Installation Overview

1. Determine that the mounting location for the 7621 is at least 18" x 20" (45.7 x 50.8 cm).
2. Use the detail below to drill 1.06" diameter holes into the mounting plate. Run tap on the threads of the base to be sure they are clean.
3. Use a crane or lifting device capable of lifting the weight of the Stellar® Crane. The 7621 weighs approximately 1,850 lbs (839 kg). **Note: Cranes are shipped with rotation positioned at 200 degrees of 400 degree system.** This will allow for easy installation of the crane and permanent connection of all hydraulic and electrical components prior to repositioning into the crane saddle.
4. Connect straps or chain from the lifting device to the lifting rings on the 7621.
5. Use four (4) 1" x 3" #8 bolts and four (4) #8 flat washers.
6. Install a washer on each bolt.
7. Apply Loctite Thread locker #277 to the bolts.
8. Using the lifting device, lower the 7621 just above the crane compartment and start the bolts. Have someone assist in leveling the crane. **Note: the rotation motor should be to the door side of crane compartment and the boom should be extended back over the rear bumper.**
9. Secure the crane using the mounting hardware provided. **Note: longer or shorter cap screws may be required – recommended thread engagement into crane base is 1.75" – use grade 8, zinc plated cap screws only.**
- 10. Torque the cap screws to 680 ft-lbs.**
11. Remove supporting crane.
12. Hook-up hydraulics and electrical.

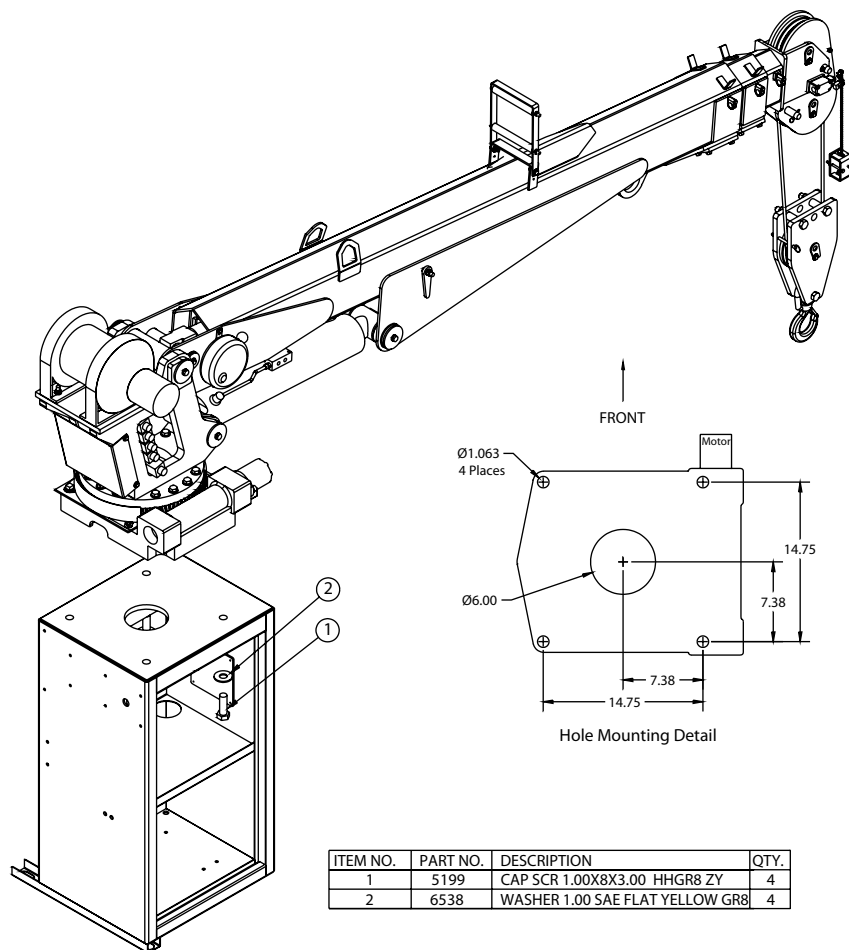

# Control Kit - PN 73249

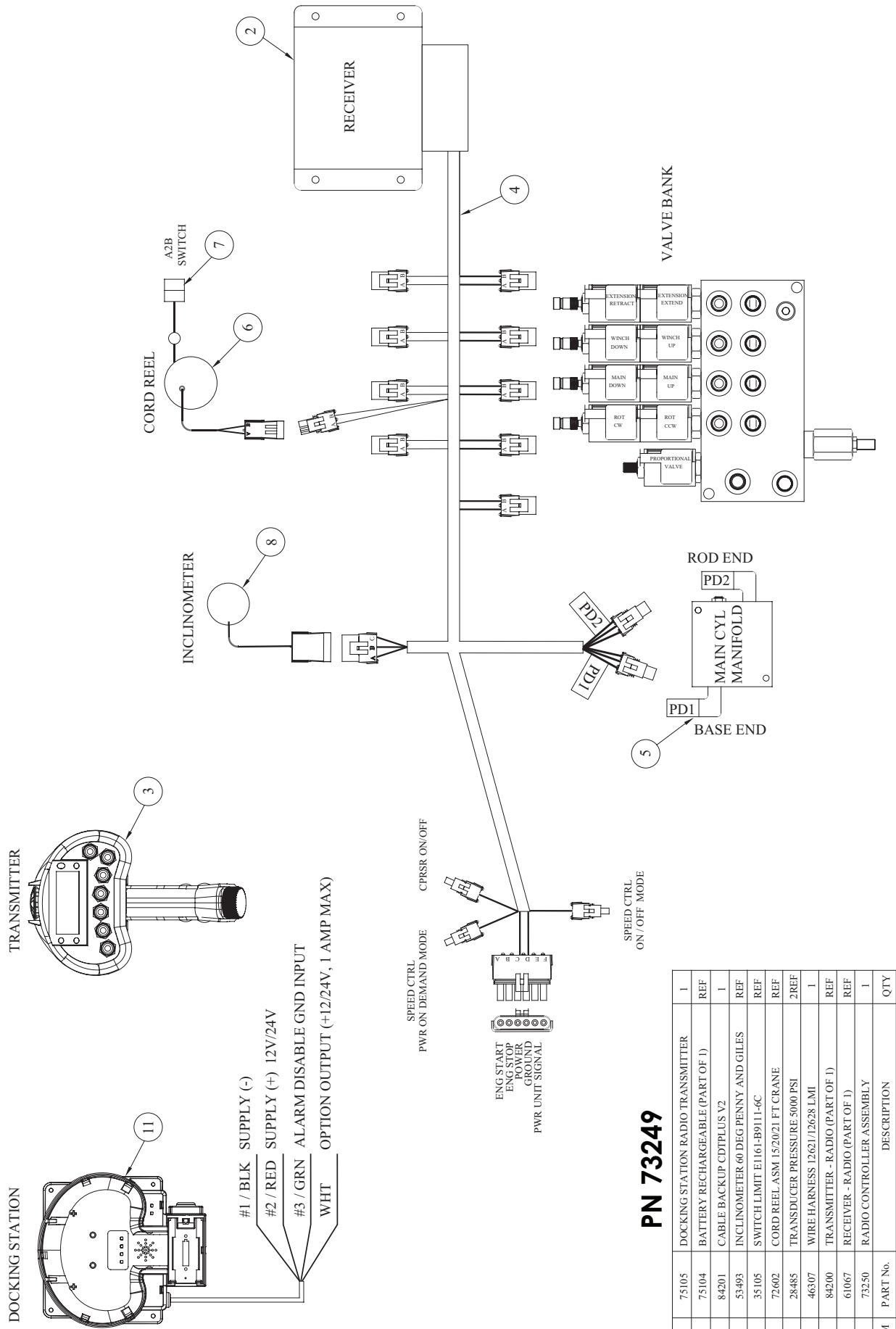

# Control Kit (Non-Boost) - PN 73252

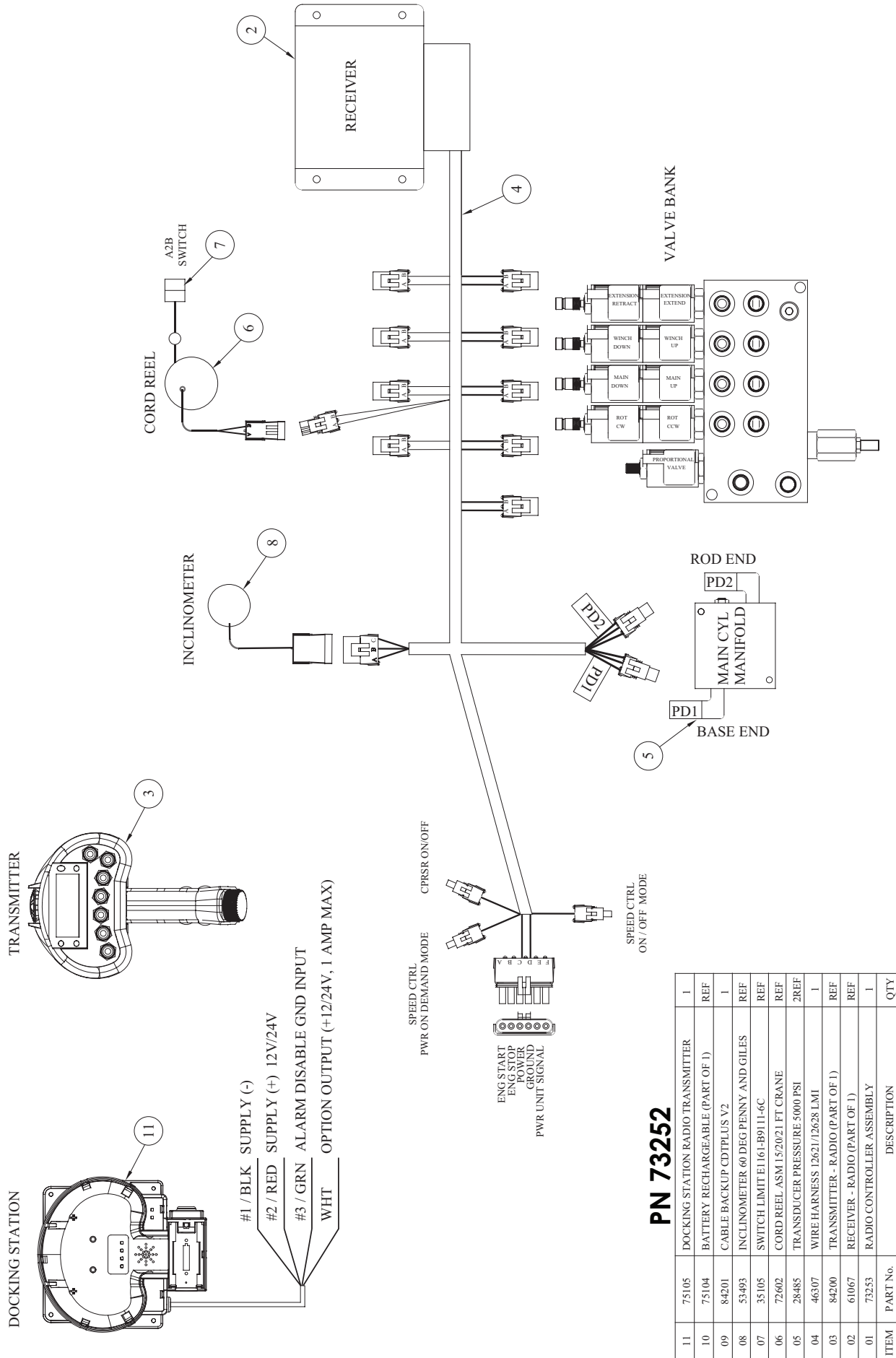

## PN 73252

ITEM	PART No.	DESCRIPTION	QTY
11	75105	DOCKING STATION RADIO TRANSMITTER	1
10	75104	BATTERY RECHARGEABLE (PART OF 1)	REF
09	84201	CABLE BACKUP CDTPLUS V2	1
08	53493	INCLINOMETER 60 DEG PENNY AND GILES	REF
07	35105	SWITCH LIMIT E1161-B9111-6C	REF
06	72602	CORD REEL ASM 15/20/21 FT CRANE	REF
05	28485	TRANSDUCER PRESSURE 5000 PSI	2REF
04	46307	WIRE HARNESS 12621/12628 LMI	1
03	84200	TRANSMITTER - RADIO (PART OF 1)	REF
02	61067	RECEIVER - RADIO (PART OF 1)	REF
01	73253	RADIO CONTROLLER ASSEMBLY	1
		DESCRIPTION	QTY

# Hydraulic Kit - PN 72758

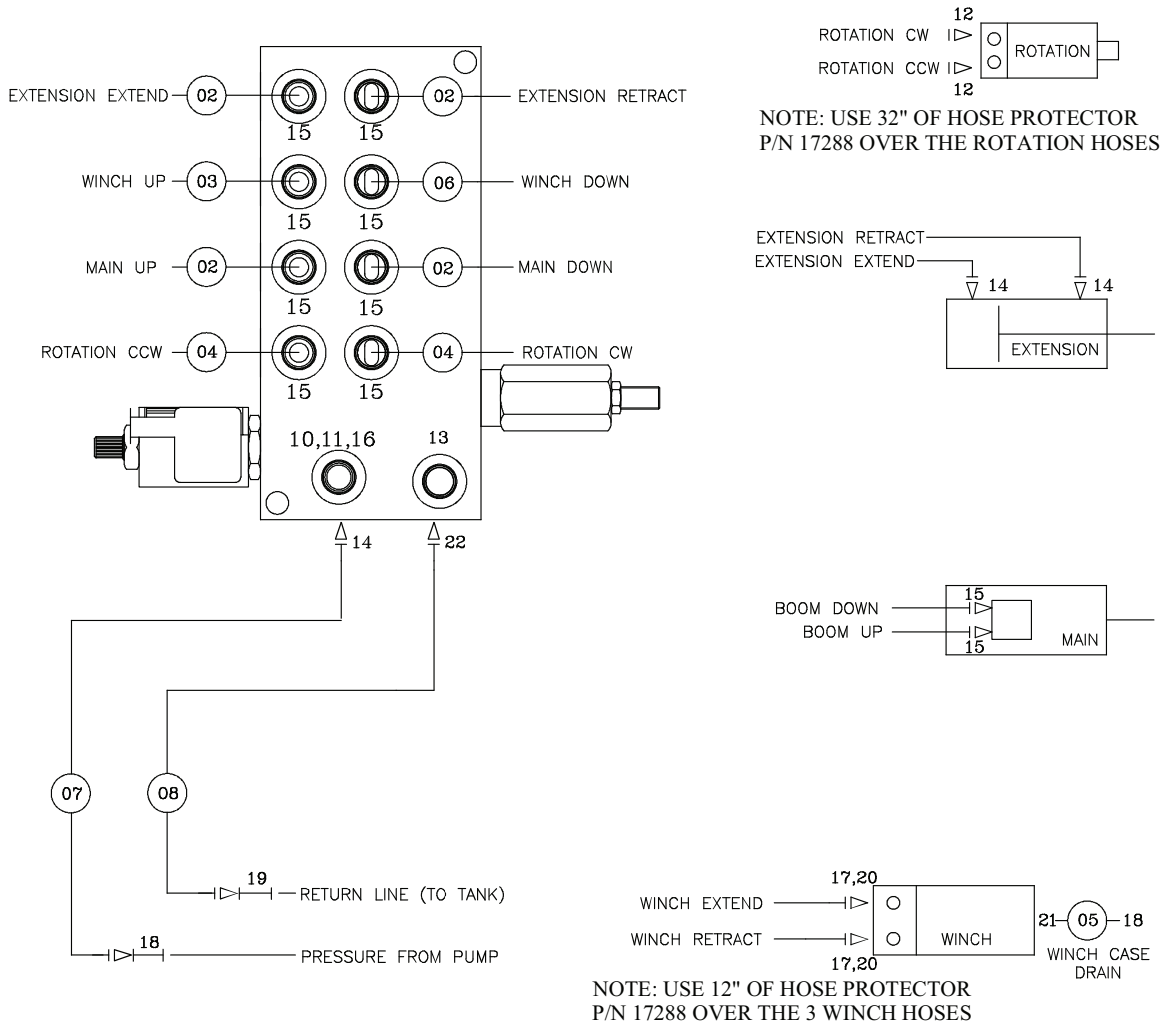

## PN 72758

23			
22	C1175	FTG 8-8 MFS-MAORB 45	1
21	C4929	FTG 6-4 MFS-MORB STRAIGHT	1
20	C5547	FTG 6-8 MFS-MOARB 90	2
19	12172	FTG 8-8 MFS-MFS SWIVEL STRAIGHT	1
18	12171	FTG 6-6 MFS-MFS SWIVEL STRAIGHT	2
17	D0549	FTG 16-8 MORB-FORB STRAIGHT REDUCER	2
16	39780	GAUGE OIL LF 2.5 0-5000 CBM SAE	1
15	0279	FTG 6-6 MFS-MORB STRAIGHT	10
14	D1193	FTG 6-6 MFS-MAORB 45	3
13	C4961	FTG 6 MORB PLUG HOLLOW HEX	1
12	D1302	FTG 6-10 MFS-MAORB 90	2
11	3861	FTG 6-6 MAORB-FORB 90	1
10	15111	FTG 6-4 MORB-FORB STRAIGHT REDUCER	1
09	17288	HOSE PROTECTOR 1.00 AS-B-27	44"
08	45438	HOSE-HYD .50 X 8	1ref
07	45439	HOSE-HYD .38 X 9	1ref
06	52276	HOSE-HYD .38 X 25	1ref
05	52486	HOSE-HYD .38 X 36	1ref
04	71903	HOSE-HYD .38 X 39	2ref
03	13029	HOSE-HYD .38 X 22.50	1ref
02	13028	HOSE-HYD .38 X 17	4ref
01	71901	HOSE KIT 76/96/106/126 (incl:2-8)	1
ITEM	PART No.	DESCRIPTION	QTY

# Valve Bank - PN 52265

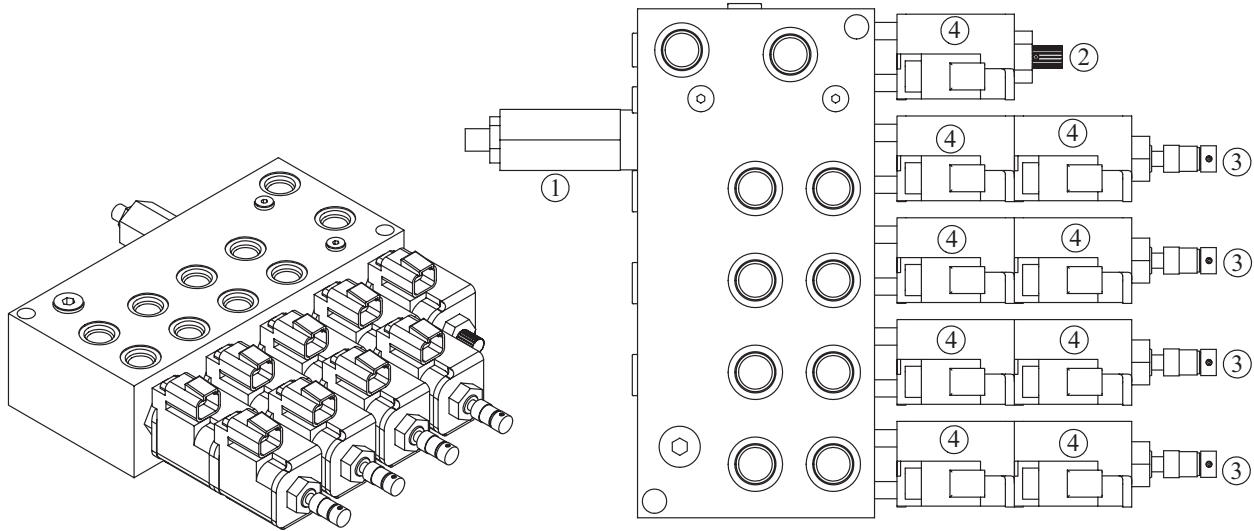

## HYDRAULIC SCHEMATIC

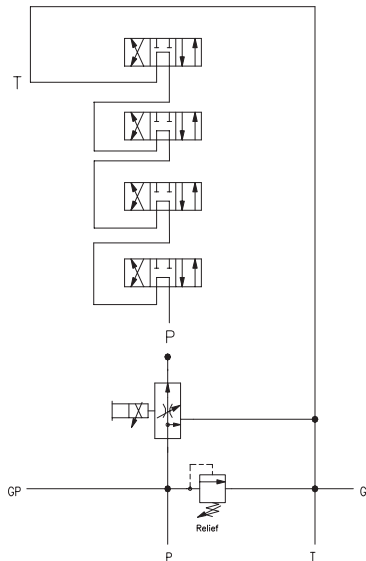

## PN 52265

ITEM	PART	DESCRIPTION	QTY	TORQUE
1	25367	RELIEF VALVE 24685/24690	1	37 FT LBS
	25368	SEAL KIT 25367		
2	24960	VALVE FLW CTRL PRP/JP04C3150N 0-8	1	20-22 FT LBS
	25369	SEAL KIT 24960/25381		
3	25371	VALVE SOLND 3 POS 4 WAY TAND G04571	4	25 FT LBS
	25373	SEAL KIT 25371/25372		
4	44532	COIL 12VDC DUETSCH CAP012H	9	3 FT LBS

**NOTE: PN's 24960 & 25371 DO NOT INCLUDE COIL PN 44532**

# Hydraulic Installation

## **! WARNING**

Follow the instructions presented on this page. Failure to follow these instructions may result in death or serious injury.

1. After mounting, locate the pressure and return lines. Note: Pressure line is 3/8" hose; Winch Case Drain Line is 3/8" hose; Return line is 1/2" hose. Hoses are terminated using swivel fittings.
2. Install hydraulic lines per diagram below. See next page for Case Drain Installation. Note: Stabilizer valve supplies oil to crane using the Power Beyond feature.
3. Install hydraulic reservoir with return filter. Attach pump pressure line to valve, return link to tank.
4. Fill system with hydraulic oil (See Stellar® Lubrication Recommendations for fluid details).

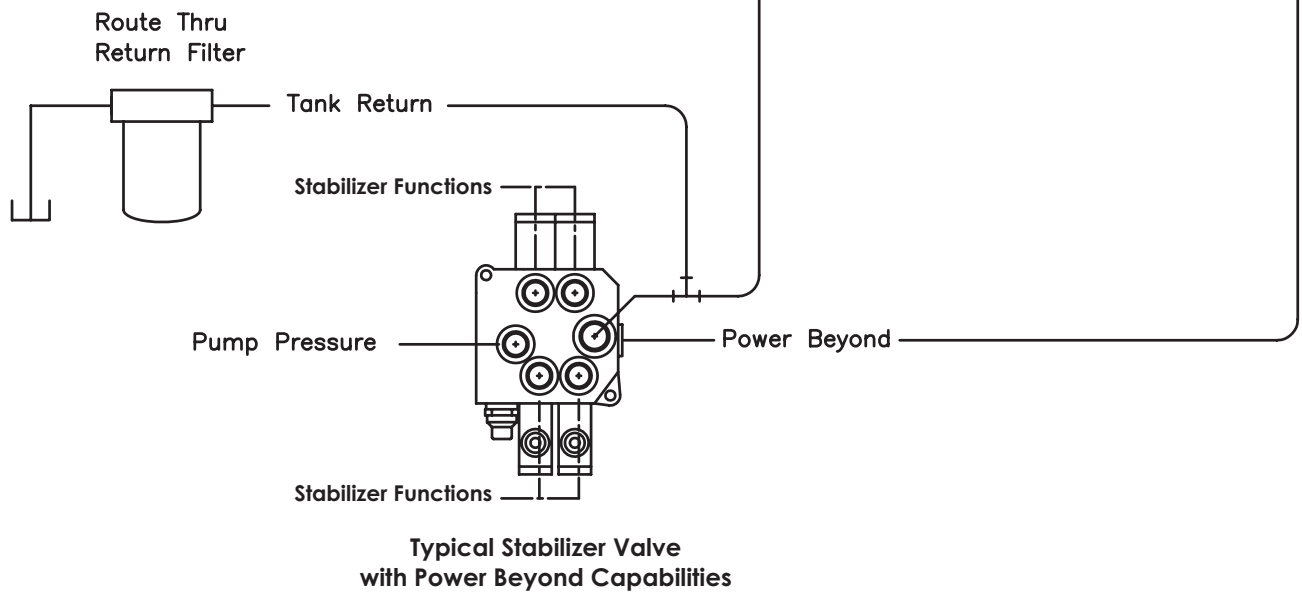
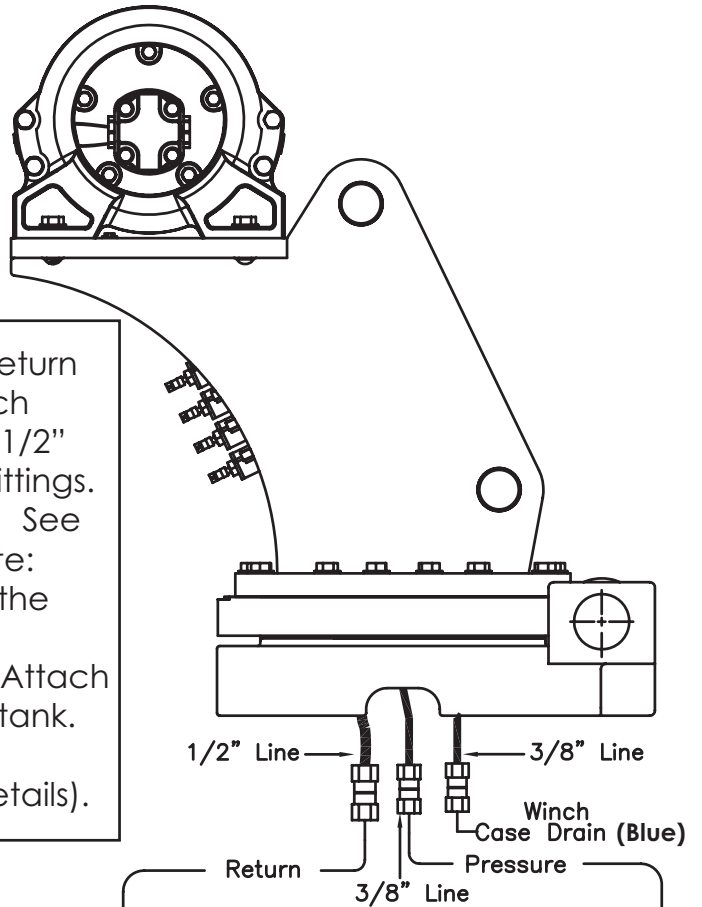



# Winch Case Drain Installation

## **WARNING**

Follow the instructions presented on this page. Failure to follow these instructions may result in death or serious injury.

### Installing the winch case drain

1. The winch case drain must run directly to the reservoir to ensure no back pressure in the line.
2. Use 3/8" hydraulic hose and fittings rated for a minimum of 300 psi.
3. Locate the winch case drain line at the bottom of the crane base as shown in Fig. 1 (Blue Hose).  
Note: Both the main pressure and winch case drane line use a 3/8" swivel fitting. Verify the winch case drain is attached to the hose that is connected to the winch motor.
4. Attach one end of the winch case drain to 3/8 swivel fitting located in step 3.
5. Route the winch case drain hose directly to the reservoir.
6. Connect the second end of the winch case drain to unshared fitting on the top of the reservoir as shown in Fig 2.

Fig.1

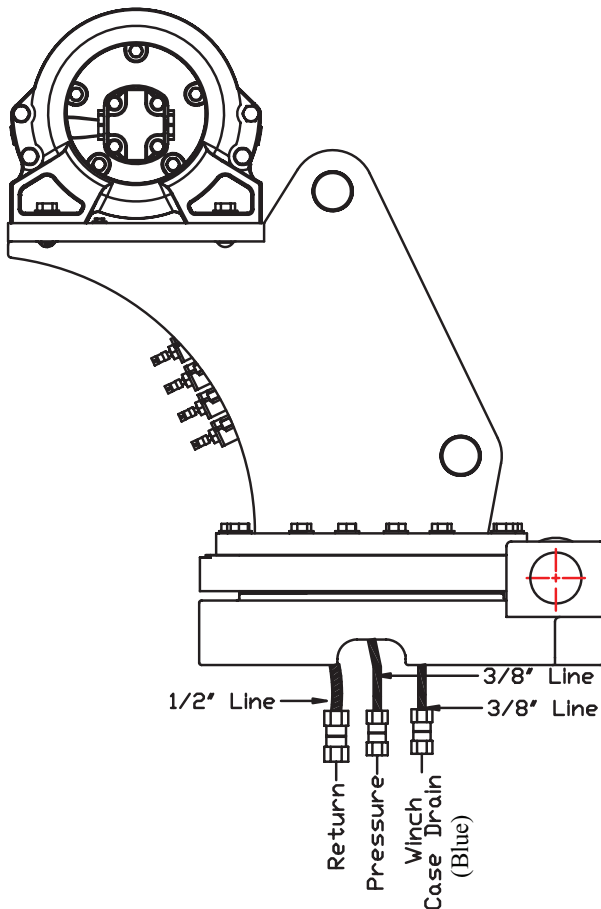
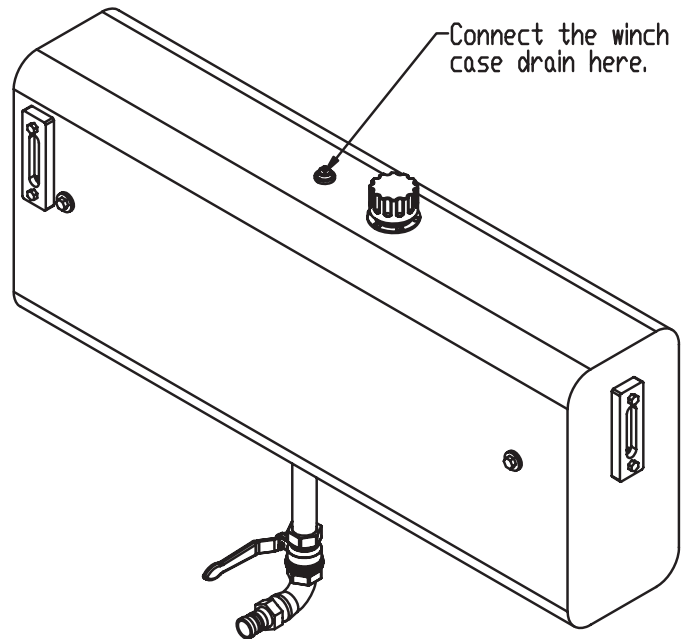
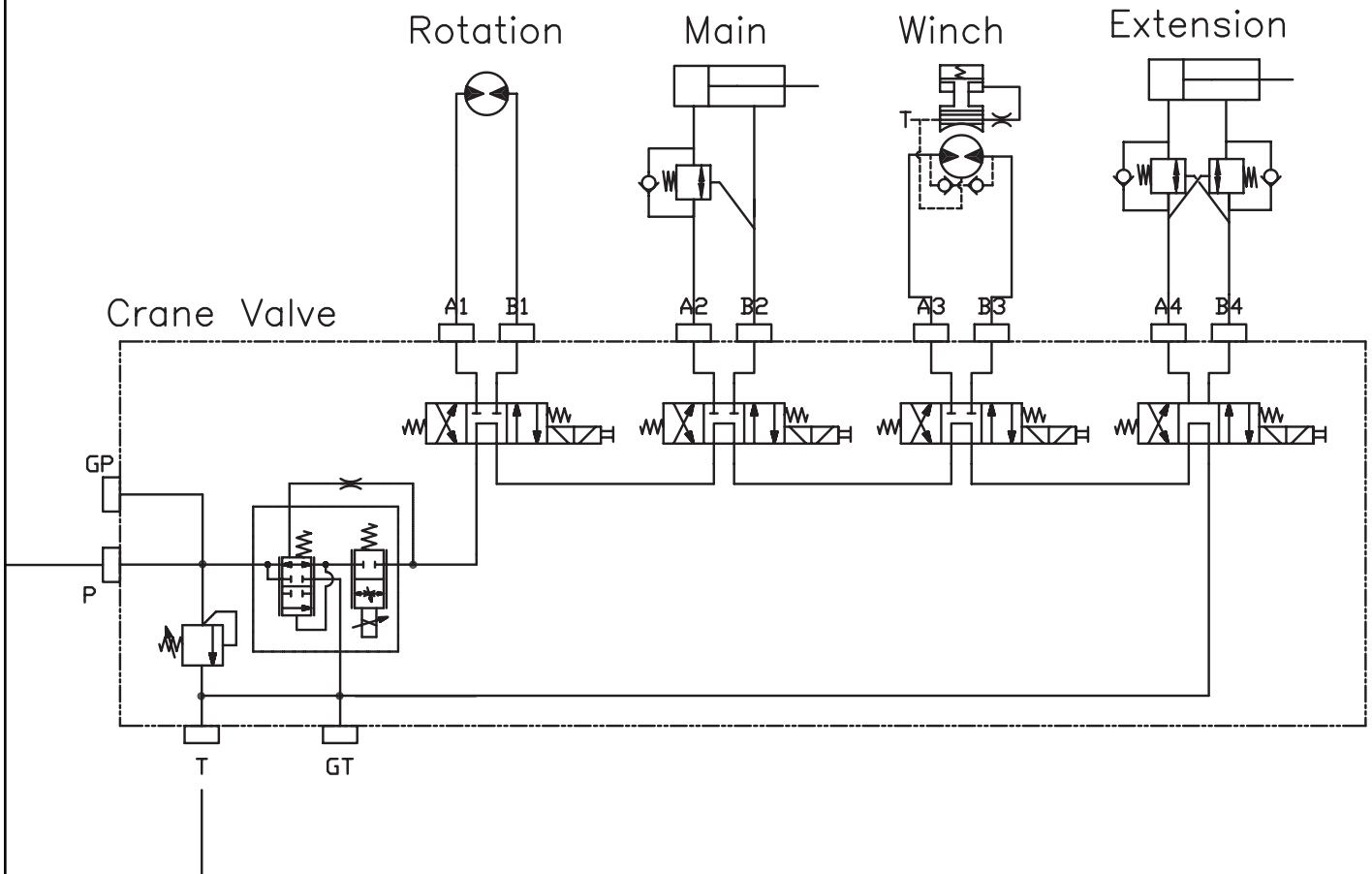

Fig. 2



# Hydraulic System



## Face Seal/O-Ring Size Chart

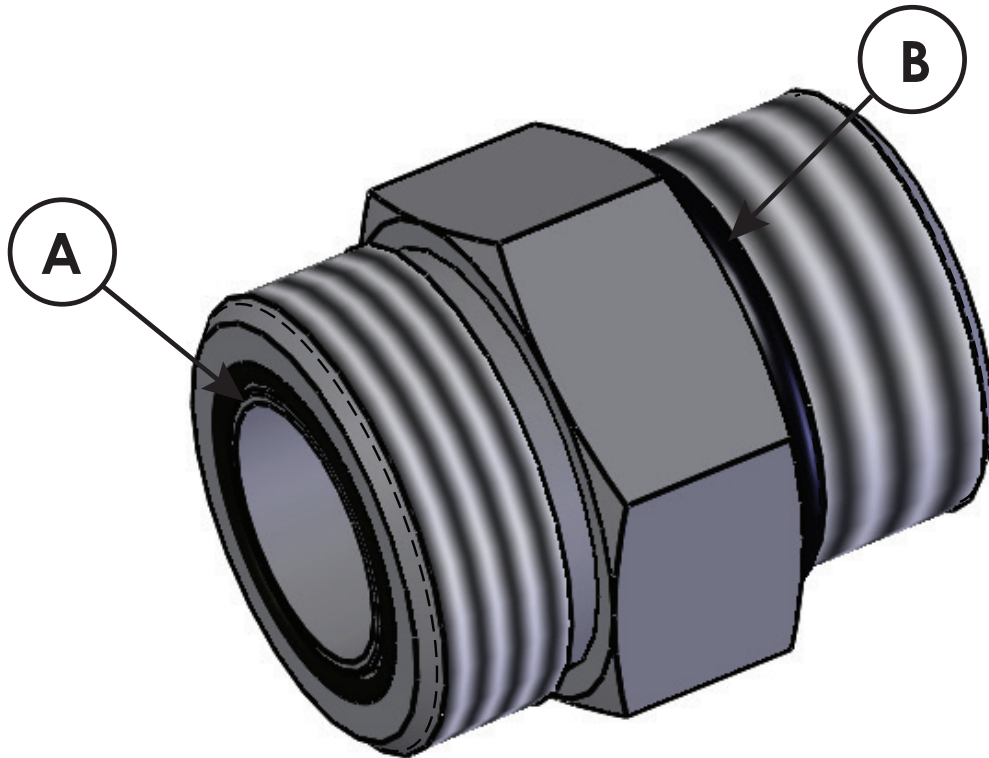

Hose Size	Fitting Size	Face Seal (A) Stellar® PN	O-ring Boss (B) Stellar® PN
1/4"	#4	C2027	D1245
3/8"	#6	C2028	D1246
1/2"	#8	C2029	D1247
5/8"	#10	32223	D1248
3/4"	#12	D1244	D1249
1"	#16		D1250

# Stability Procedure

## Definition of Stability for the Stellar Telescopic Crane Products:

A truck is stable until the load cannot be lifted off the ground with the winch, without tipping over the truck. Every Stellar crane installed must be tested for stability to determine the actual load capacity of the final truck package. The actual test data must be recorded and supplied with the truck at the time of in-service and should be kept with the truck at all times. The following procedure will test the truck package for stability and will provide a stability capacity chart. The load limit information shown on the stability capacity chart is formulated on 85% tipping.

## Set Up:

1. Locate the truck on a test course in position for loading and engage travel brakes.
2. Set stabilizers so that they make contact with firm, level footing.
3. Operate the crane under partial load to assure operator proficiency and proper machine function.
4. Put the radio into Stability Test Mode:
  - A. Push the middle four switches up and hold until "STB" appears on the screen (approximately 5 seconds.)



- B. At this point, the crane will have enough capacity to handle the weight for the stability test.
- C. The radio will timeout of stability mode after 30 minutes or when the E-Stop button is pushed.

*Note: The radio can only be put into stability mode five times. After that, the radio would have to be returned to Stellar to be reprogrammed to allow additional stability testing. All other radio functions will work properly even if stability mode is not available.*

# Stability Procedure Continued...

## 7621 Stability Data

**Max Horizontal Reach:** 251" (From the center of rotation to boom tip)

**Boost Stability Test Weight:** 2,520 lbs.

**Non-Boost Stability Test Weight:** 2,135lbs.

## Test Procedure

1. Rotate the crane into Zone 1 position.
2. With the crane fully retracted and the boom horizontal, winch the test weight off the ground. Note: Keep weight within six inches of the ground at all times.
3. Extend the boom outward until full extension has been reached or until the truck becomes unstable (Again, use the winch to keep the weight within six inches of the ground.)
4. If the boom goes full extension without becoming unstable, the crane is termed stable for this zone and 100% can be written in the Zone 1 data box.
5. If the truck becomes unstable prior to going full extension, retract the boom until the truck becomes stable and measure the horizontal reach in this position (center of rotation to boom tip). This is the stable horizontal reach for this zone. Stable horizontal reach divided by Maximum horizontal reach multiplied by 100 equals the percentage of rated capacity for this zone. Use the following formula to determine the percentage of rated capacity:

$$\frac{\text{Stable Horizontal Reach}}{\text{Max Horizontal Reach}} \times 100 = \text{Percentage of Rated Capacity}$$

6. Record this number in the data box for Zone 1. This is the revised capacity due to stability for this zone.
7. Repeat this procedure for each zone until the worksheet is completed.
8. This is the revised capacity based on stability of this package.

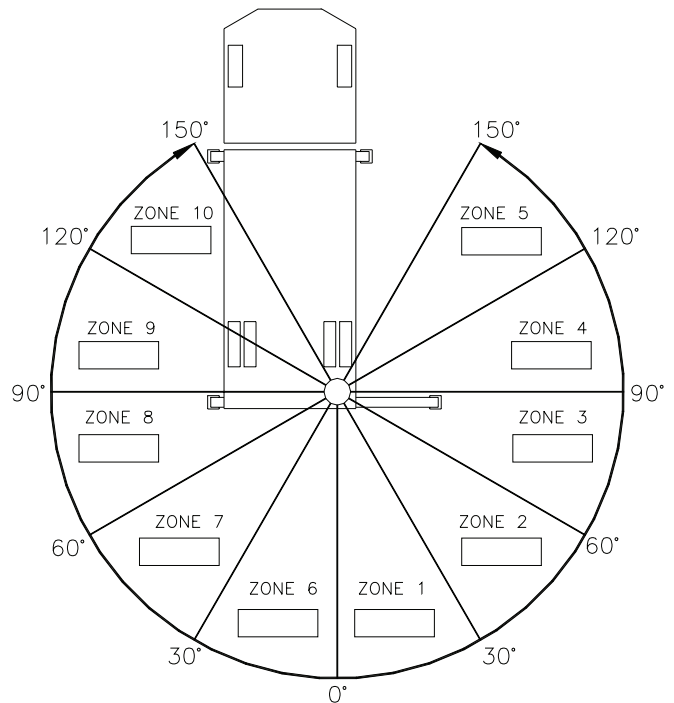

# Decal Placement - PN 72800

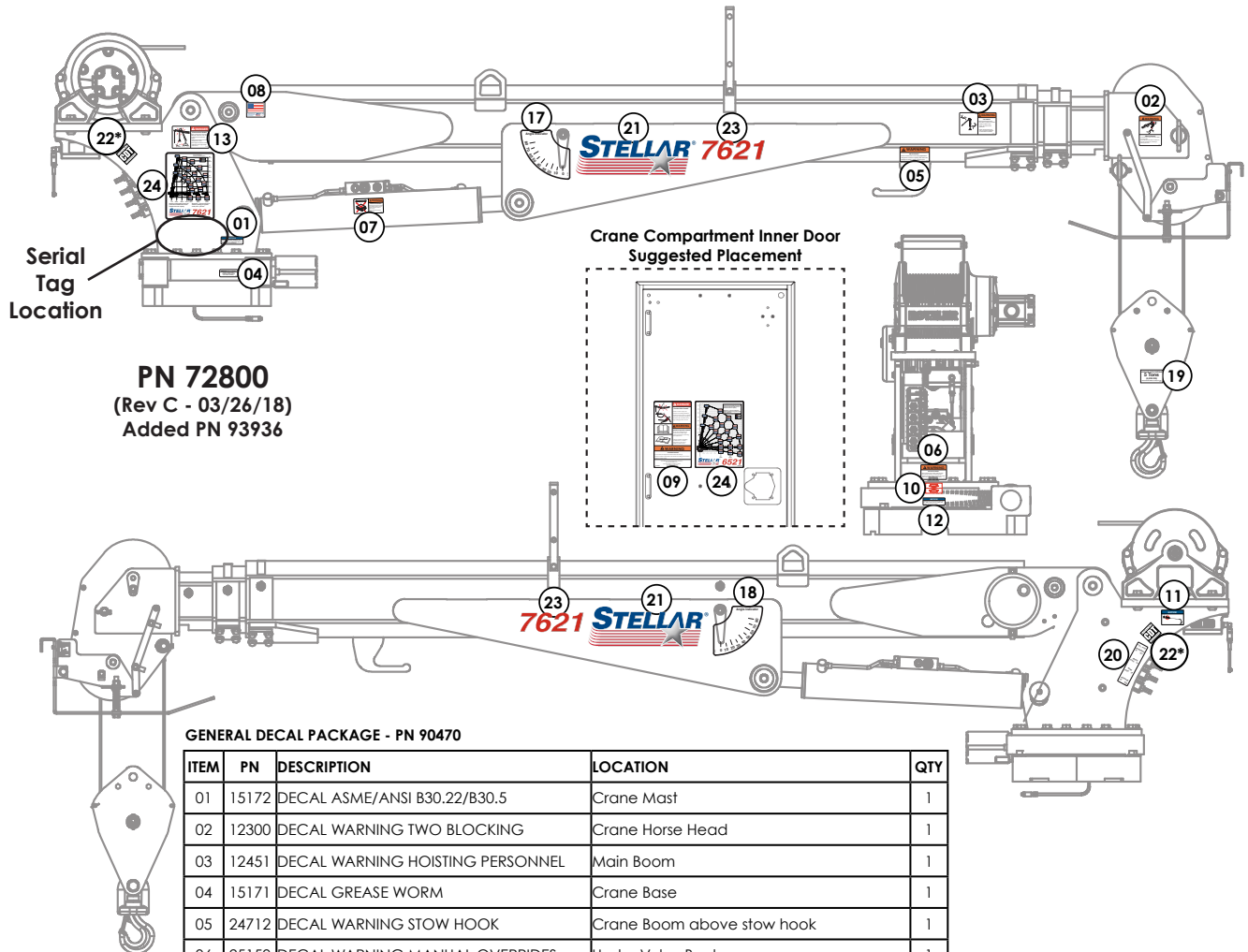

**PN 72800**  
(Rev C - 03/26/18)  
Added PN 93936

## GENERAL DECAL PACKAGE - PN 90470

ITEM	PN	DESCRIPTION	LOCATION	QTY
01	15172	DECAL ASME/ANSI B30.22/B30.5	Crane Mast	1
02	12300	DECAL WARNING TWO BLOCKING	Crane Horse Head	1
03	12451	DECAL WARNING HOISTING PERSONNEL	Main Boom	1
04	15171	DECAL GREASE WORM	Crane Base	1
05	24712	DECAL WARNING STOW HOOK	Crane Boom above stow hook	1
06	25159	DECAL WARNING MANUAL OVERRIDES	Under Valve Bank	1
07	28256	DECAL WARNING OVERLOAD DEVICE	Main Cylinder	1
08	35234	DECAL STELLAR MADE IN THE USA	Main Boom	1
09	93936	DECAL SAFETY & SERVICE MECH BODY DOOR	Crane Compartment	1
10	4188	DECAL ROTATION ALIGNMENT	Crane Base	1
11	73929	DECAL PRESSURE WASH	Crane Mast	1
12	9188	DECAL ROTATE/GREASE	Crane Base	1
13	C1179	DECAL DANGER ELECTROCUTION SMALL	Crane Mast	1
14**	C4545	DECAL DANGER ELECTROCUTION LARGE	Four corners of the body/chassis	4
15**	C5910	DECAL STELLAR 4x9.5	Suggested: Rear body/tailgate	1
16**	C5911	DECAL STELLAR 2x4.5	Suggested: Side corners of body	3
17	D1196	DECAL ANGLE INDICATOR CS	Main Boom	1
18	D1197	DECAL ANGLE INDICATOR SS	Main Boom	1

## 7621 DECAL PACKAGE - PN 90475

ITEM	PN	DESCRIPTION	LOCATION	QTY
19	38472	DECAL SNATCH BLOCK 5 TON	Snatch Block	1
20	52270	DECAL VB CONTROL MECH CRANE	On side of Crane Mast	1
21	52681	DECAL STELLAR LOGO 6.5 X 18	Main Boom (Both Sides)	2
22*	54588	DECAL CDT 2.00 x 2.00	<b>CDT ONLY - Crane Mast (Both Sides)</b>	2
22*	71895	DECAL CDT PLUS 2.00 x 2.00	<b>CDT PLUS ONLY - Crane Mast (Both Sides)</b>	2
23	54959	DECAL IDENTIFICATION 7621 V2	Main Boom (Both Sides)	2
24	72801	DECAL CAPACITY 7621	Main Boom and Crane Compartment	2

\* For CDT™ equipped cranes, use PN 54588. For CDTplus™ equipped cranes, use PN 71895.

\*\* Not shown.

# Chapter 3 - Assembly Drawings

## Base Assembly - PN 50364

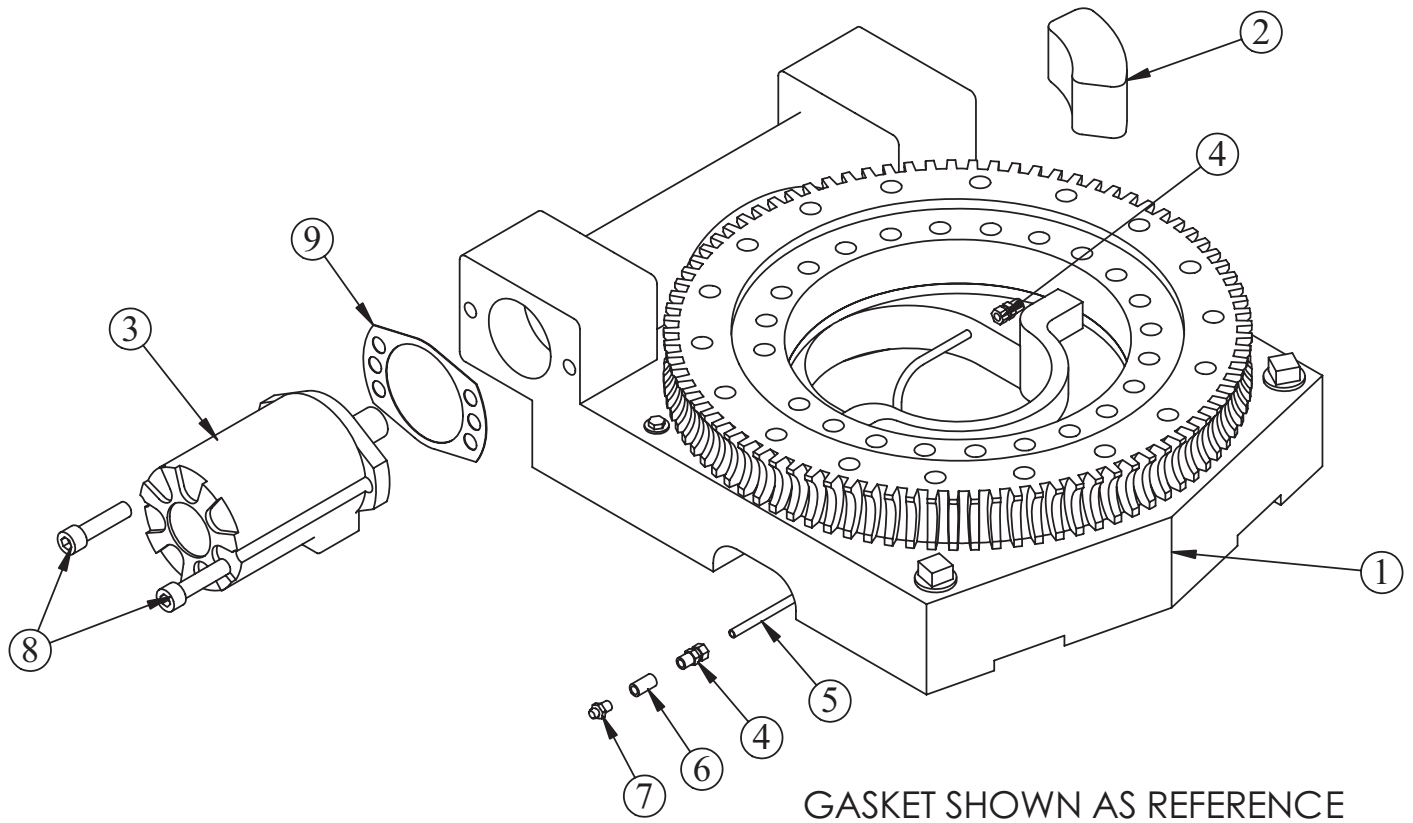

### PN 50364

ITEM	PART	DESCRIPTION	QTY.
1	47869	BEARING SWING DRIVE CAST 6620 GEARTEK	1
2	11542	STOP 6620 400 SLIDE	1
3	C6069	MOTOR HYD ROSS MK080613AAAB	1
4	D1345	FTG CPRSN 0.12NPT/0.25 TUBE	2
5	D1810	TBE AIR SAEJ844 TYPE A .25 (RM)	2.5
6	22161	FTG 2-2 FP-FP COUPLER STRAIGHT BRASS	1
7	56589	ZERK 1/8 NPT STRAIGHT LONG THREAD	1
8	53495	CAP SCR 0.50-13X2.00 SH	2
9	21151	GASKET MOTOR 008-10056-1	1

NOTE: ITEM 1 INCLUDE GUARD & GUARD FASTENERS

# Gear Bearing - PN 47869

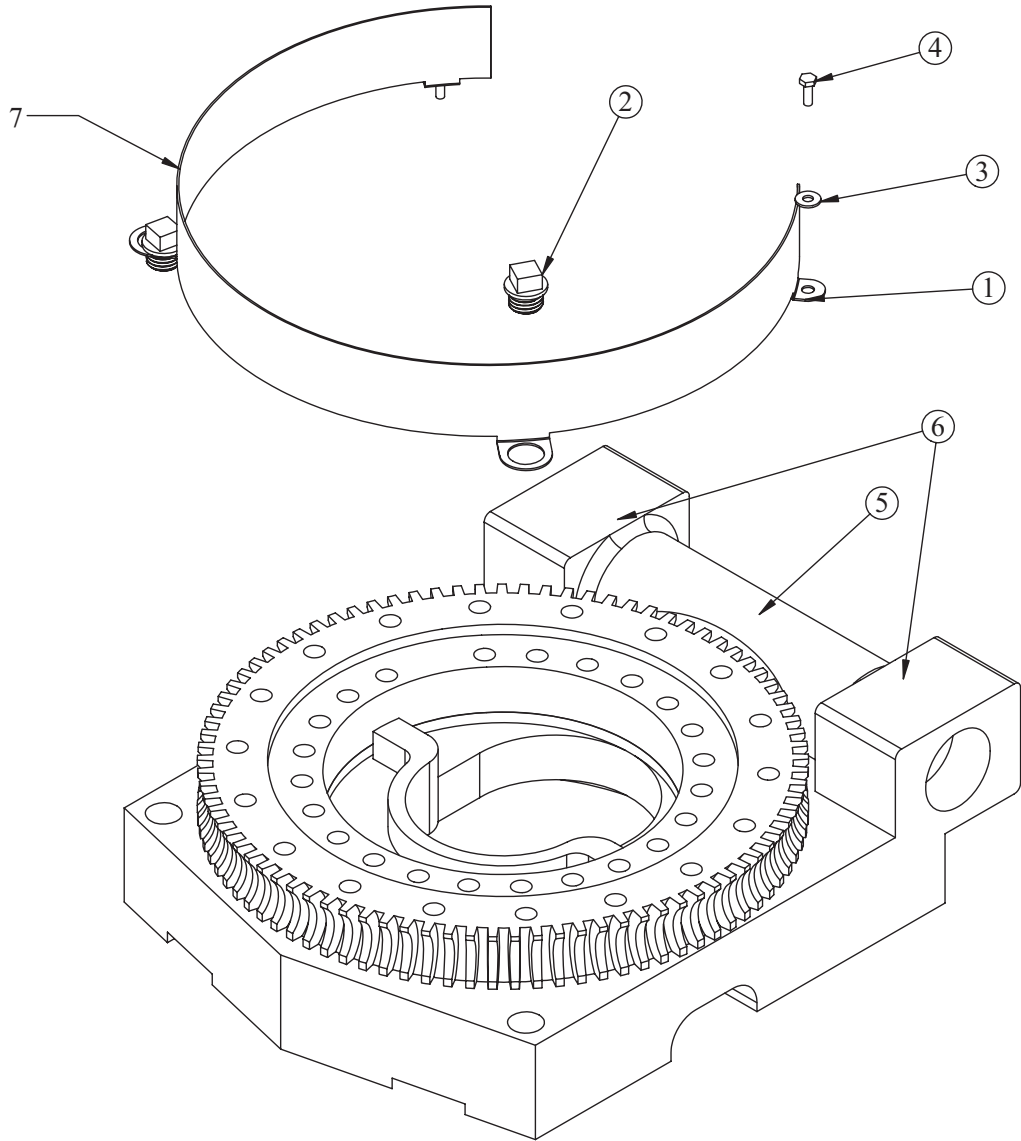

## PN 47869

ITEM	PART	DESCRIPTION	QTY.
1	44551PC	GUARD ITB 6620 CRANE LZR	1
2	13959	CAP SCR 1.00-8 X .63 PLASTIC	2
3	0340	WASHER 0.25 FLAT	2
4	0479	CAP SCR 0.25-20X0.75 HHGR5	2
5	55827	WORM PERFECTION 66/76	1
6	55829	BEARING AND SEAL KIT 66/76 PERFECTION CAST	1
7	20445	TRIM EDGE 0.06X0.56 AL 0.63 BULB	42"



# Mast Assembly - PN 72789

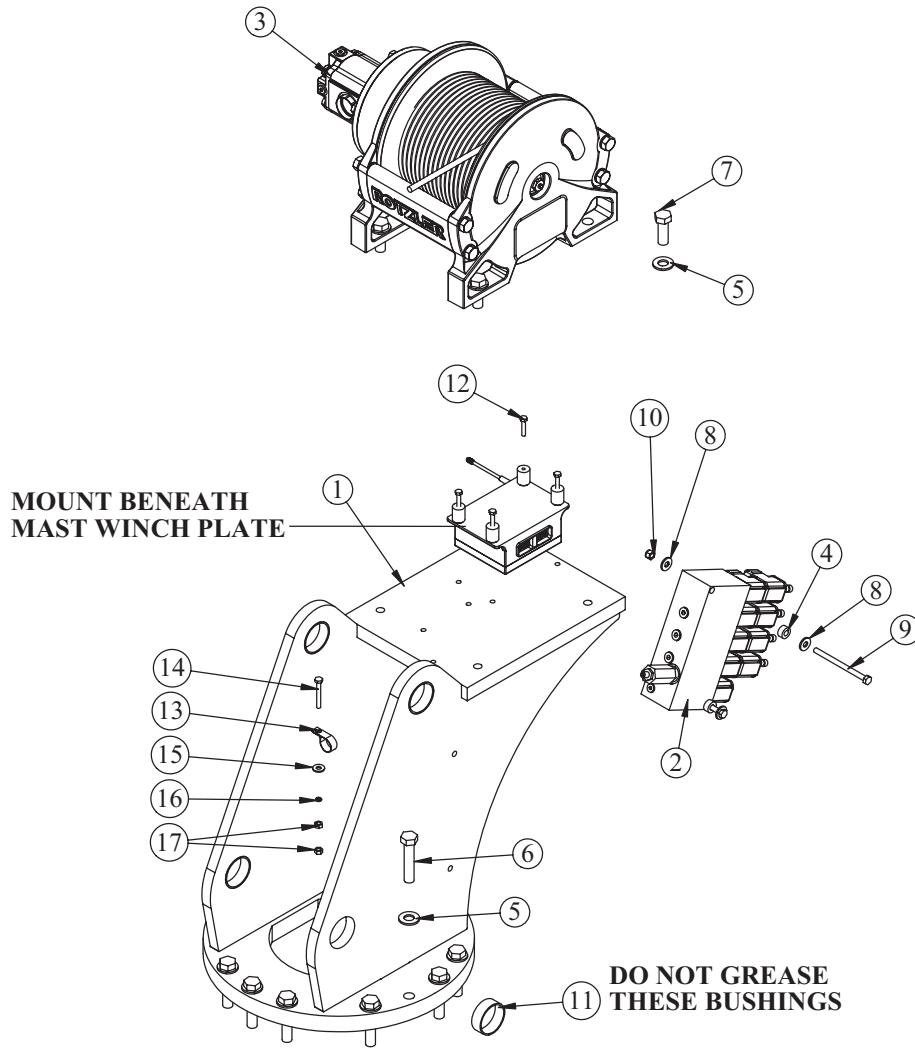

## PN 72789

ITEM	PART	DESCRIPTION	QTY.
1	70824	MAST 126/106/96/76	1
2	52265	VB 4 SECT W/PROP STER8GPM DEUTSCH	1
3	63516	WINCH 3750 TH2CC230246 W/100 FT ROPE	1
4	27813	COLLAR 0.38X0.75X0.38 UHMW	2
5	C5902	WASHER 0.63 SAE FLAT YELLOW GR8	18
6	D1034	CAP SCR 0.63-11X3.00 HHGR8 W/RED PATCH	14
7	11693	CAP SCR 0.63-11X1.75 HHGR8	4
8	0343	WASHER 0.31 USS FLAT ZINC	4
9	C0933	CAP SCR 0.31-18X4.50 HHGR5	2
10	0342	NUT 0.31-18 HHGR5 NYLOC	2
11	44533	BUSHING COMPOSITE 2.00X0.75	4
12	52490	CAP SCR 6MMX30MM HH 8.8(GR5)	4
13	C5946	HOSE CLAMP #8 RUBBER COATED	1
14	0481	CAP SCR 0.25-20X2.00 HHGR5	1
15	0340	WASHER 0.25 USS FLAT ZINC	1
16	0521	WASHER 0.25 LOCK	1
17	0533	NUT 0.25-20 HHGR5	2

## RADIO RECEIVER RUBBER MOUNT 64977

# Winch - PN 63516

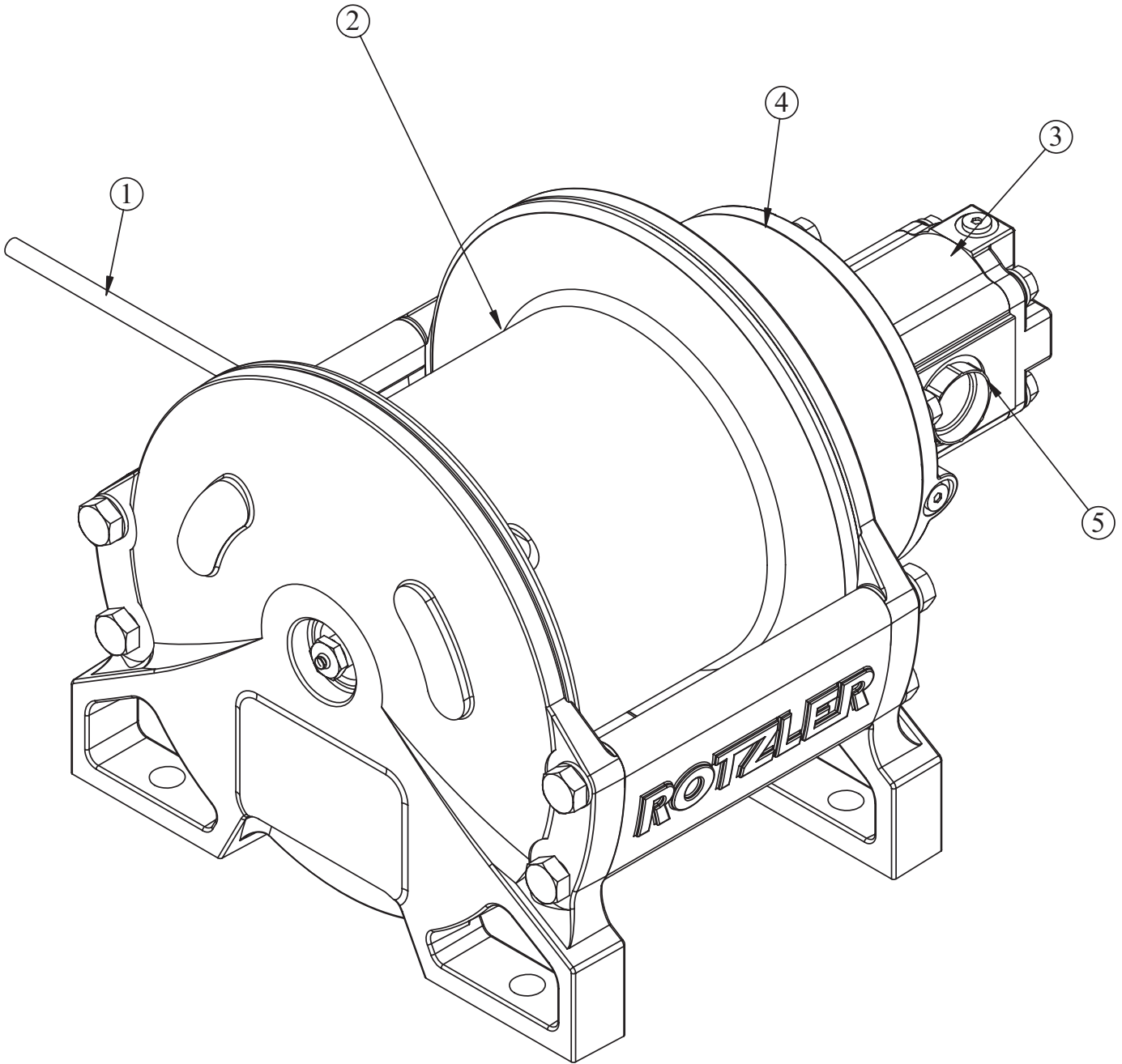

## PN 63516

ITEM	PART	DESCRIPTION	QTY.
1	13403	WIRE ROPE 3/8 6X31 IWRC-DGXIP 100FT	1
2	53492	SEAL KIT ROTZLER TH2 WINCH	1
3	71907	SEAL KIT ROTZLER WINCH MOTOR 23CC/31CC	1
4	72680	SEAL & HARDWARE KIT WINCH MOTOR COVER ROTZLER TH2	1
5	71905	MOTOR WINCH 3750 ROTZLER M.TH2.CC.23	1

# Main Boom Assembly - PN 72790

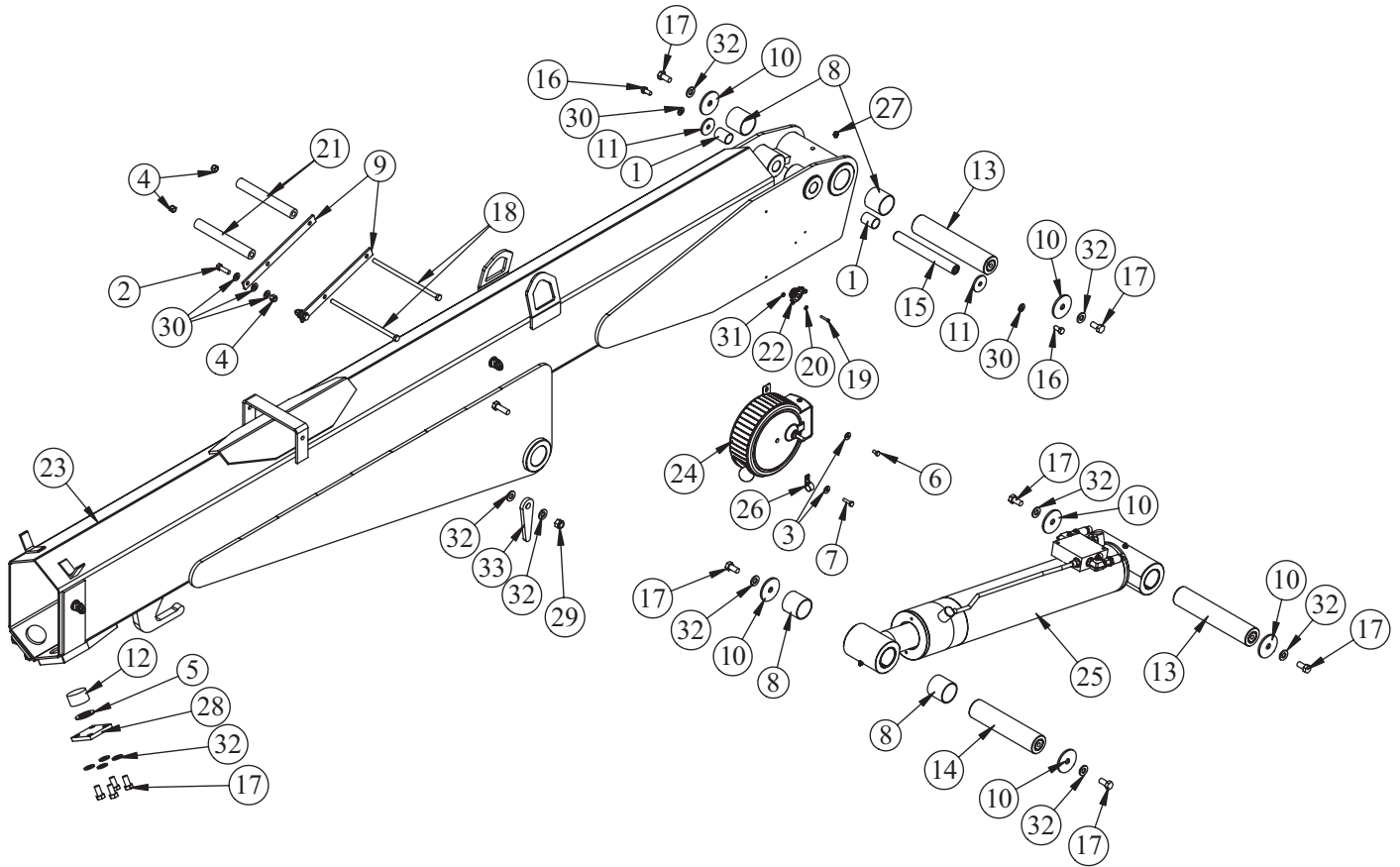

## PN 72790

ITEM	PART	DESCRIPTION	QTY.	ITEM	PART	DESCRIPTION	QTY.
1	0068	BUSHING BPC16DXR24 1.00X1.50	2	13	9709CR	PIN 2.00X10.19 D&T	2
2	0335	CAP SCR 0.38-16X1.25 HHGR5	2	14	9711CR	PIN 2.00X8.88 D&T	1
3	0340	WASHER 0.25 USS FLAT ZINC	2	15	9712CR	PIN 1.00X8.38 SR/D&T	1
4	0347	NUT 0.38-16 HHGR5 NYLOC	4	16	9843	CAP SCR 0.38-16X0.75 HHGR8	2
5	0425	MACHY WASHER 1.25ID 10GA	2	17	10172	CAP SCR 0.50-13X1.00 HHGR8	14
6	0478	CAP SCR 0.25-20X0.50 HHGR5	1	18	12168	CAP SCR 0.38-16X9.00 HHGR5	2
7	0480	CAP SCR 0.25-20X1.00 HHGR5	1	19	18618	SCREW #6-32X1.00 PHMS PH	2
8	4381	BUSHING BPC32DXR32 2.00X2.00	4	20	18765	WASHER #6 SAE FLAT ZINC	2
9	69470PC	BRKT ROPE GUIDE 4421	2	21	27720	SPACER ROPE GUIDE 6620 UHMW	2
10	9142	PIN CAP 0.56X2.50X0.19	6	22	53493	INCLINOMETER 60 DEG	1
11	9320	PIN CAP 0.44X1.75X0.19 SS	2	23	71057	INNER BOOM 7621	1
12	9363	WEAR PAD 1.12X2.00 RND NYLATRON	2	24	72602	CORD REEL ASM 15/21 FT CRANE	1
				25	71461	CYLINDER ASM 4.50X22.50	1
				26	C0078	CLAMP 0.38 BLK VINYL	1
				27	c1592	ZERK 1/8 NPT STRAIGHT	1
				28	9545	PLATE WEAR PAD SUPPORT	2
				29	C6106	NUT 0.50-13 HHGR5 NYLOC	2
				30	C6353	WASHER 0.38 SAE FLAT YELLOW GR8	8
				31	D0076	NUT #6-32 HH NYLOC SS	2
				32	D0790	WASHER 0.50 SAE FLAT YELLOW GR8	18
				33	D1194	PLATE ANGLE INDICATOR	2

# Extension Boom Assembly - PN 71056

## PN 71056

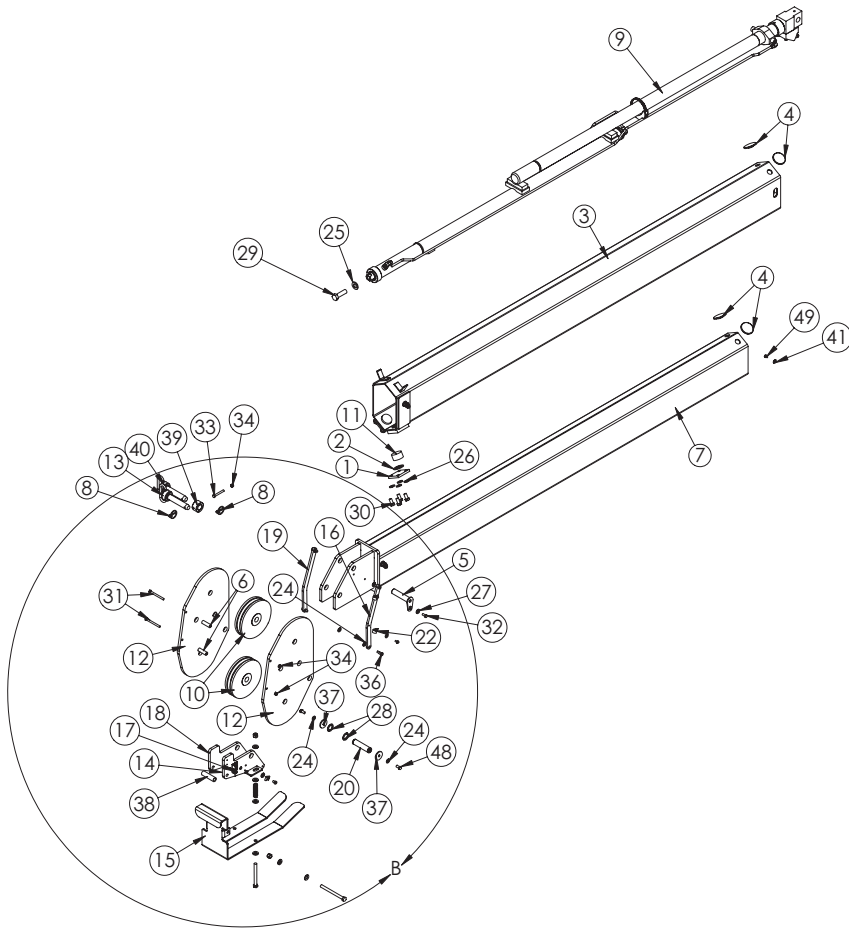

ITEM	PART	DESCRIPTION	QTY.
1	9545PC	PLATE WEAR PAD SUPPORT	2
2	0425	MACHY WASHER 1.25ID 10GA	2
3	71061	EXT BOOM 1ST 7621	1
4	6252	WEAR PAD 0.19X2.50 RND NYLATRON	4
5	13400ZP	PIN TEAR DROP 1.00X4.38	1
6	27719	SPACER BOOM TIP 6620 UHMW	2
7	71065	EXT BOOM 2ND 7621 FS/CRADLE A2B	1
8	5753	PIN 0.19X1.56 LYNCH	2
9	49316	CYLINDER EXT ASM 6620 2.0/2.0	1
10	13339	SHEAVE 7621 8.00 DIA .38R/1.88THK	2
11	9363	WEAR PAD 1.12X2.00 RND NYLATRON	2
12	71459	PLATE SHEAVE MOUNTING FS/CRADLE 12630	2
13	12824	PIN HITCH 1.00X4.50	1
14	61051	MNT CRADLE LH FS/CRADLE A2B 106/126	1
15	61048	CRADLE FS/CRADLE A2B 106/126	1
16	71462	LINK FS/CRADLE A2B 12630 W/HOLES	1
17	35105	SWITCH LIMIT E1117-B9111-6C	1
18	61054	MNT CRADLE RH FS/CRADLE A2B 106/126	1
19	71463	LINK FS/CRADLE A2B 12630	1
20	37680ZP	PIN 1.00X4.19 SR	1
21	27710	SPRING ANTI 2 BLOCK CRADLE A2B	2
22	C0078	CLAMP 0.38 BLK VINYL	2
23	31279	CLAMP 0.31 BLK VINYL	1
24	C6353	WASHER 0.38 SAE FLAT YELLOW GR8	6
25	C6219	WASHER 0.75 SAE FLAT YELLOW GR8	1
26	D0790	WASHER 0.50 SAE FLAT YELLOW GR8	18
27	0343	WASHER 0.31 USS FLAT ZINC	2
28	0867	MACHY WASHER 1.00ID 14GA	2
29	4974	CAP SCR 0.75-10X2.50 HHGR8 W/RED PATCH	1
30	10172	CAP SCR 0.50-13X1.00 HHGR8	8
31	0490	CAP SCR 0.31-18X3.50 HHGR5	2
32	0420	CAP SCR 0.31-18X0.75 HHGR5	1
33	0489	CAP SCR 0.31-18X2.50 HHGR5	1
34	0342	NUT 0.31-18 HHGR5 NYLOC	3
35	31132	CAP SCR #10-24X0.550 SH SS 18-8	2
36	61053	BOLT SHOULDER 0.38X0.50 0.31-18X0.50	4
37	9320	PIN CAP 0.56X3.50X.25	2
38	61548PC	PIPE 0.50X 3.13 SCH40	1
39	61549PC	COLLAR 1.13X2.00X1.13 W/HOLE	1
40	45125	PIN HITCH 1.00 FORK KPCC	1
41	0340	WASHER 0.25 USS FLAT ZINC	3
42	0478	CAP SCR 0.25-20X0.50 HHGR5	2
43	0484	CAP SCR 0.31-18X0.50 HHGR5	1
44	C1000	CAP SCR 0.50-13X5.00 HHGR5	2
45	D0178	WASHER #10 SAE FLAT ZINC	2
46	C6106	NUT 0.50-13 HHGR5 NYLOC	3
47	C1002	CAP SCR 0.50-13X6.00 HHGR5	1
48	9843	CAP SCR 0.38-16X0.75 HHGR8	2
49	43845	CAP SCR 0.25-20X0.38 HHGR5	1

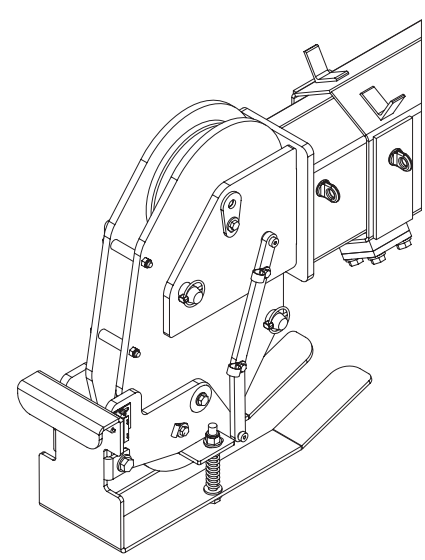
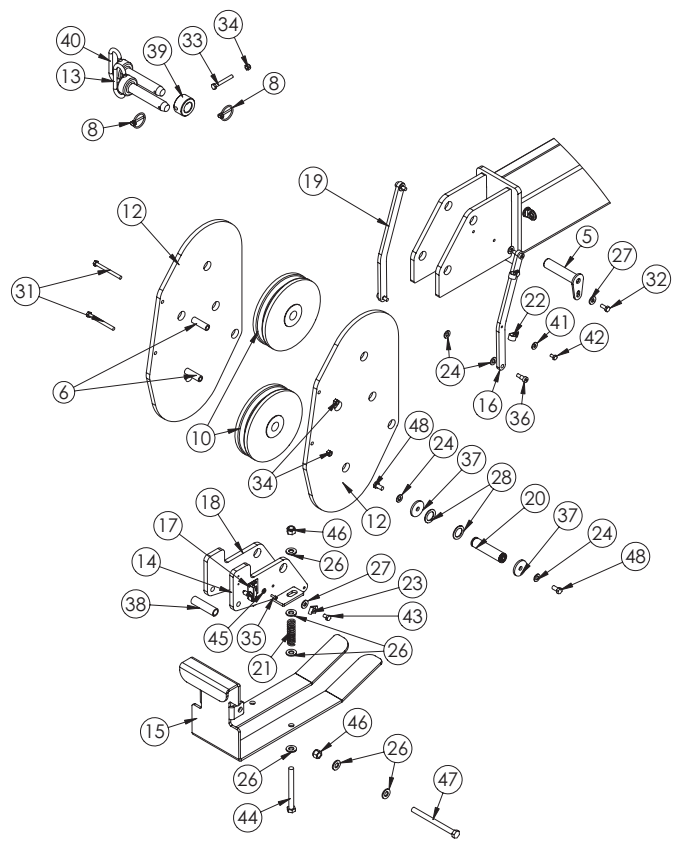

# Main Cylinder Assembly (Before 11/14/14) - PN 72756

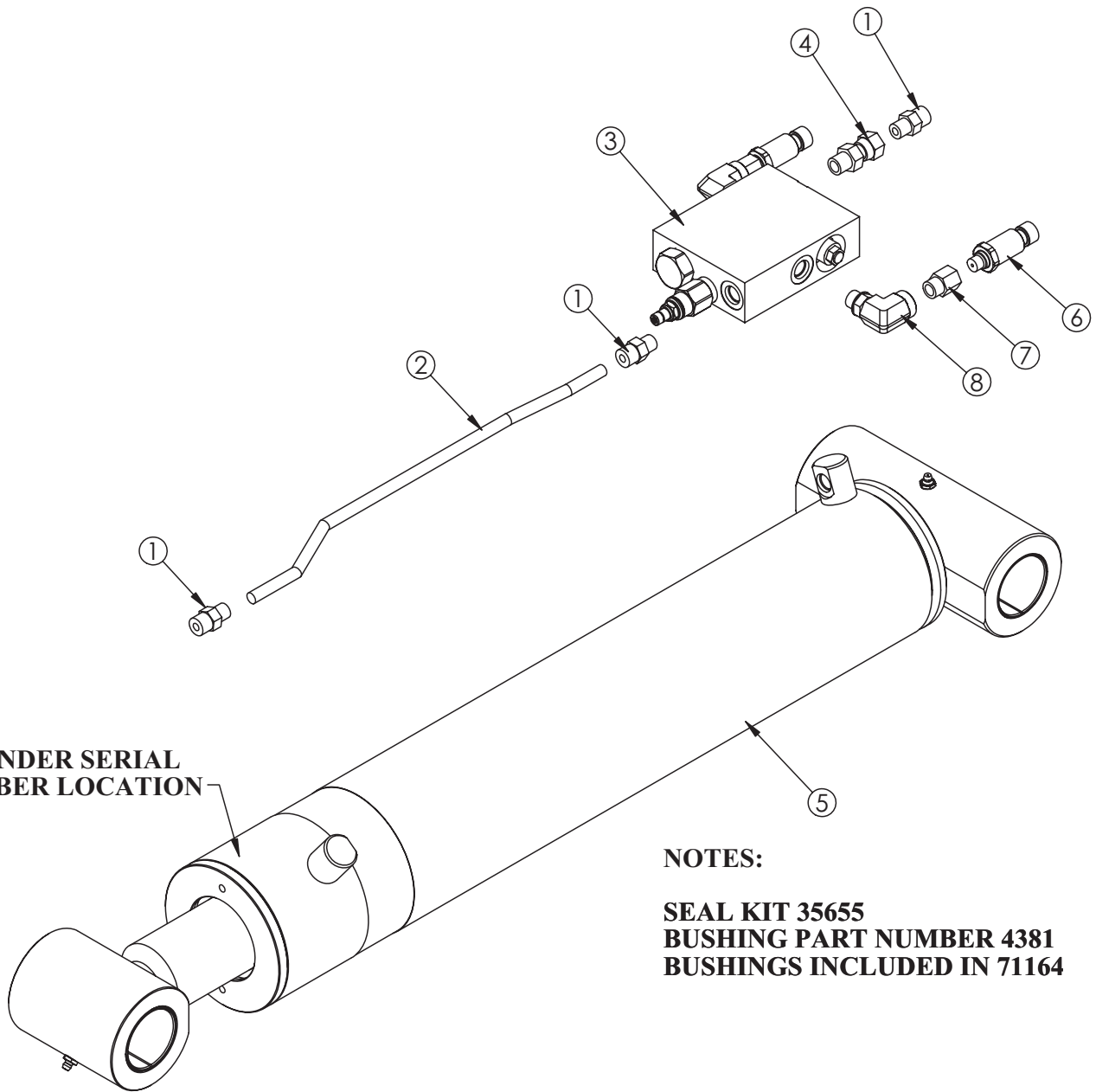

## PN 72756

ITEM	PART	DESCRIPTION	QTY.
1	0279	FTG 6-6 MFS-MORB STRAIGHT	3
2	72757	TUBE ASM 0.38 X 15.47	1
3	41910	MANIFOLD ASM MAIN CYL CDT	1
4	33743	FTG 6-6 FFSS-MORB STRAIGHT	1
5	71164	CYLINDER 4.50X22.50	1
6	28485	TRANSDUCER PRESSURE 5000 PSI	2
7	15111	FTG 6-4 MORB-FORB STRAIGHT REDUCER	2
8	3861	FTG 6-6 MAORB-FORB 90	2

# Main Cylinder Assembly (As of 11/14/14) - PN 71461

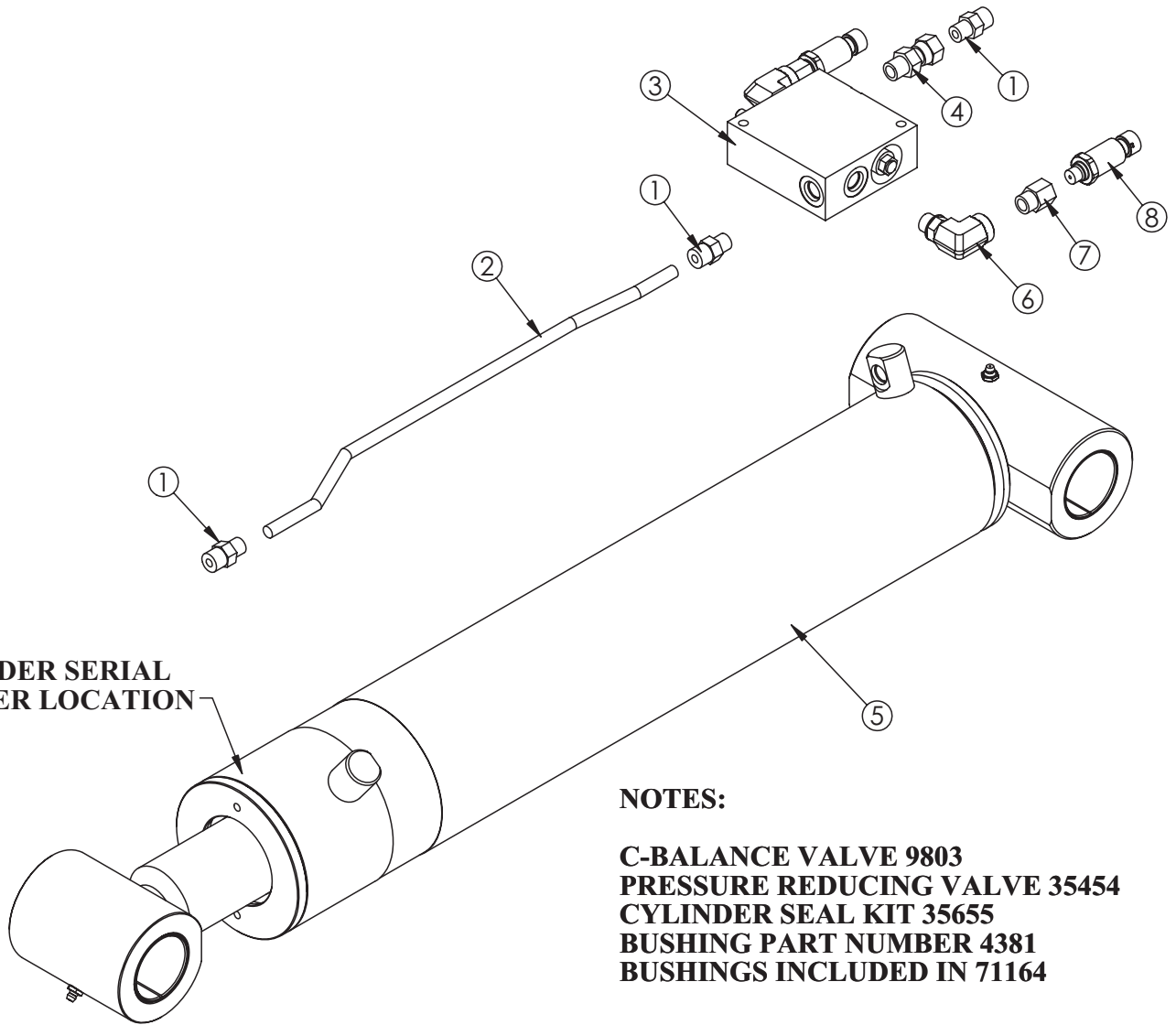

## PN 71461

ITEM	PART	DESCRIPTION	QTY.
1	0279	FTG 6-6 MFS-MORB STRAIGHT	3
2	71460	TUBE ASM 0.38 X 16.72 12630 MAIN CYL	1
3	13080	MANIFOLD SINGLE T11A 3500 PSI	1
4	33743	FTG 6-6 FFSS-MORB STRAIGHT	1
5	71164	CYLINDER 4.50X22.50	1
6	3861	FTG 6-6 MAORB-FORB 90	2
7	15111	FTG 6-4 MORB-FORB STRAIGHT REDUCER	2
8	28485	TRANSDUCER PRESSURE 5000 PSI	2

# Extension Cylinder Assembly - PN 49316

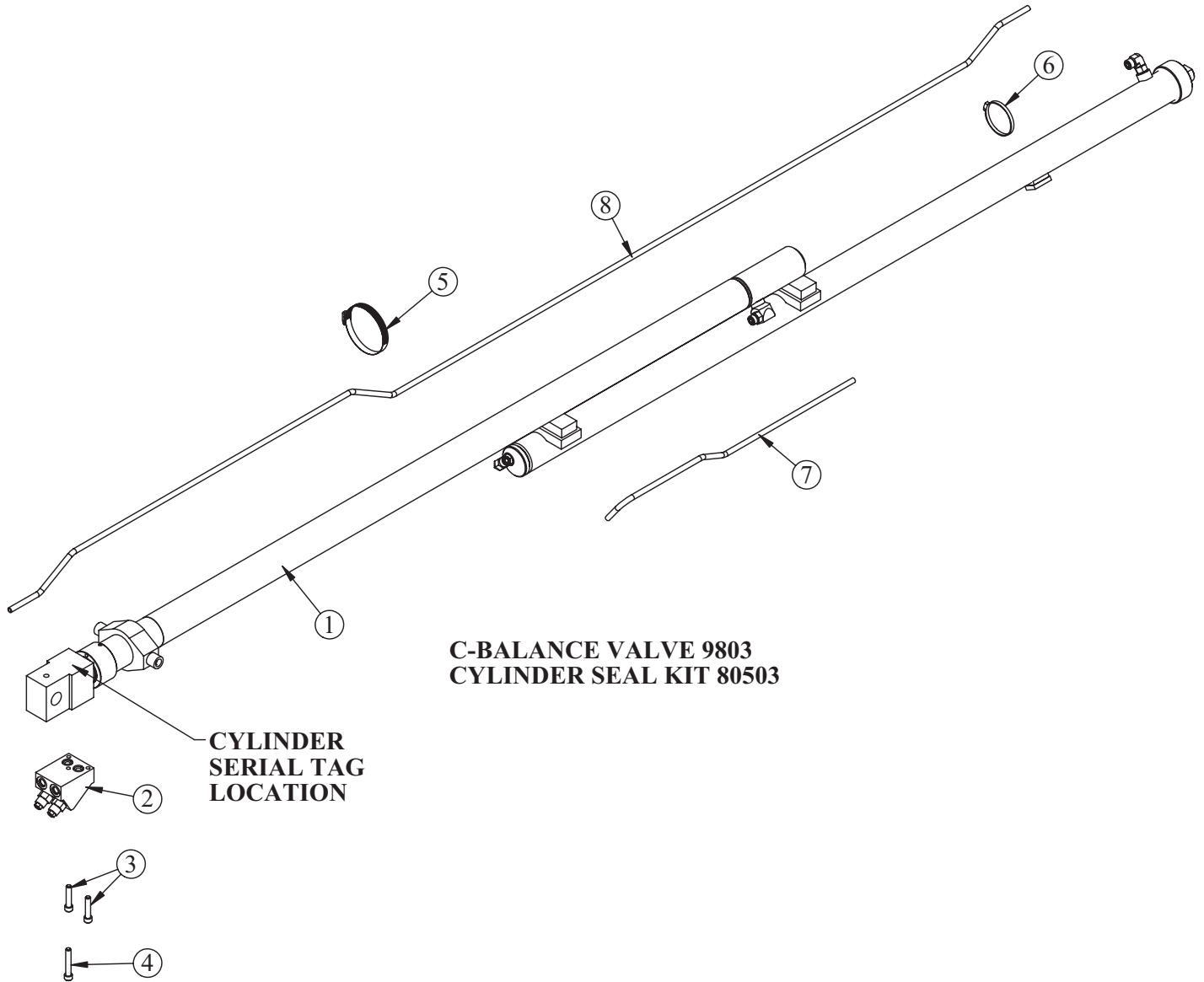

## PN 49316

ITEM	PART	DESCRIPTION	QTY.
1	37548	CYLINDER EXT 2 STAGE 2.0/2.0 PTD 60	1
2	14115	MANIFOLD ASM 6620 EXT CBBB-LJN-XVN	1
3	11882	CAP SCR 0.38-16X1.75 SH ZC	2
4	14601	CAP SCR 0.38-16X2.25 SH ZC	1
5	24729	HOSE CLAMP #52 3.00 - 3.75	1
6	D0655	HOSE CLAMP #36 WRM GEAR	1
7	87827	TUBE ASM 0.38X23.25 EXT CYL 7621/12621 YZ	1
8	88393	TUBE ASM 0.38X102.13 EXT CYL 7621/12621 YZ	1

# Cable & Hook Assembly - PN 56266

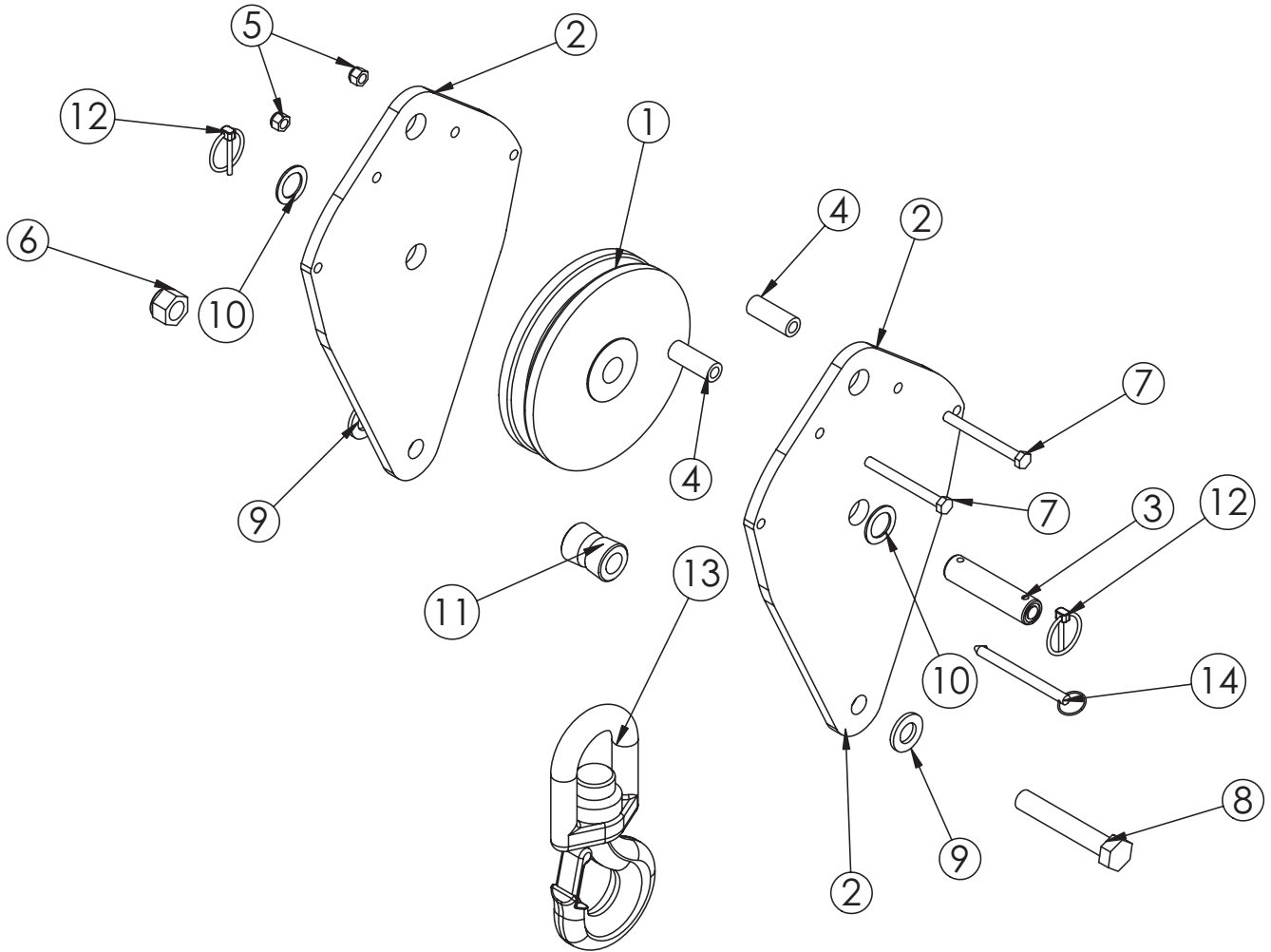

## PN 56266

ITEM	PART	DESCRIPTION	Default
1	13339	SHEAVE 7621 8.00 DIA .38R/1.88THK	1
2	53263PC	PLATE SNATCH BLOCK 76/96/106/126	2
3	39874ZP	PIN 1.00X4.06 COTTER	1
4	44643	COLLAR 0.44X0.75X2.00	2
5	0347	NUT 0.38-16 HHGR5 NYLOC	2
6	C0538	NUT 0.75-10 HHGR8 NYLOC	1
7	0532	CAP SCR 0.38-16X3.75 HHGR5	2
8	5841	CAP SCR 0.75-10X4.50 HHGR8	1
9	C6219	WASHER 0.75 SAE FLAT YELLOW GR8	2
10	0867	MACHY WASHER 1.00ID 14GA	2
11	39844ZP	BUSHING V HOOK SS	1
12	5753	PIN 0.19X1.56 LYNCH	2
13	25831	HOOK 5 TON SWIVEL CROSBY 1028623	1
14	13436	PIN .38X4.00 QUICK RELEASE	1



# Chapter 4 - Replacement Parts

---

Part Number	Description	Qty
C6069	Rotation Motor	1
25367	Relief Valve	1
25368	Seal Kit - Relief Valve	1
24960	Proportional Valve	1
25371	Solenoid Valve - Tandem G04571	3
25372	Solenoid Valve - Open G04591	1
25373	Seal Kit - Solenoid Valve	1
44532	Coil	9
13080	Manifold ASM - Main Lift Cylinder	1
9803	C-Balance Valve	2
35454	Presssure Reducing Valve	1
11991	Plug - C-Balalance Valve	1
14115	Manifold ASM - Extension Cylinder	1
35655	Seal Kit - Main Lift Cyl	1
80503	Seal Kit - Extension Cyl	1
28485	Pressure Transducer	2
53493	Inclineometer	1
74554	Extension Sensor	1
37980	Hydraulic Pressure Gauge	1
12171	FTG 6-6 MFS-MFS Swivel Straight	1
12172	FTG 8-8 MFS-MFS Swivel Straight	1
13339	Sheave	2
13339	Sheave	1
13403	Wire Rope	1
12824	Hitch Pin 1.00 x 4.50	1
45125	Hitch Pin 1.00 Fork	1
13436	Quick Release Pin .38 x 4.00	1
35105	Limit Switch	1
72602	Cord Reel	1
25831	Hook	1
71905	Winch Motor	1
71907	Winch Motor Seal Kit	1
53492	Winch Seal Kit	1



Subject to Change without Notification.  
© 2018 Stellar Industries, Inc.