

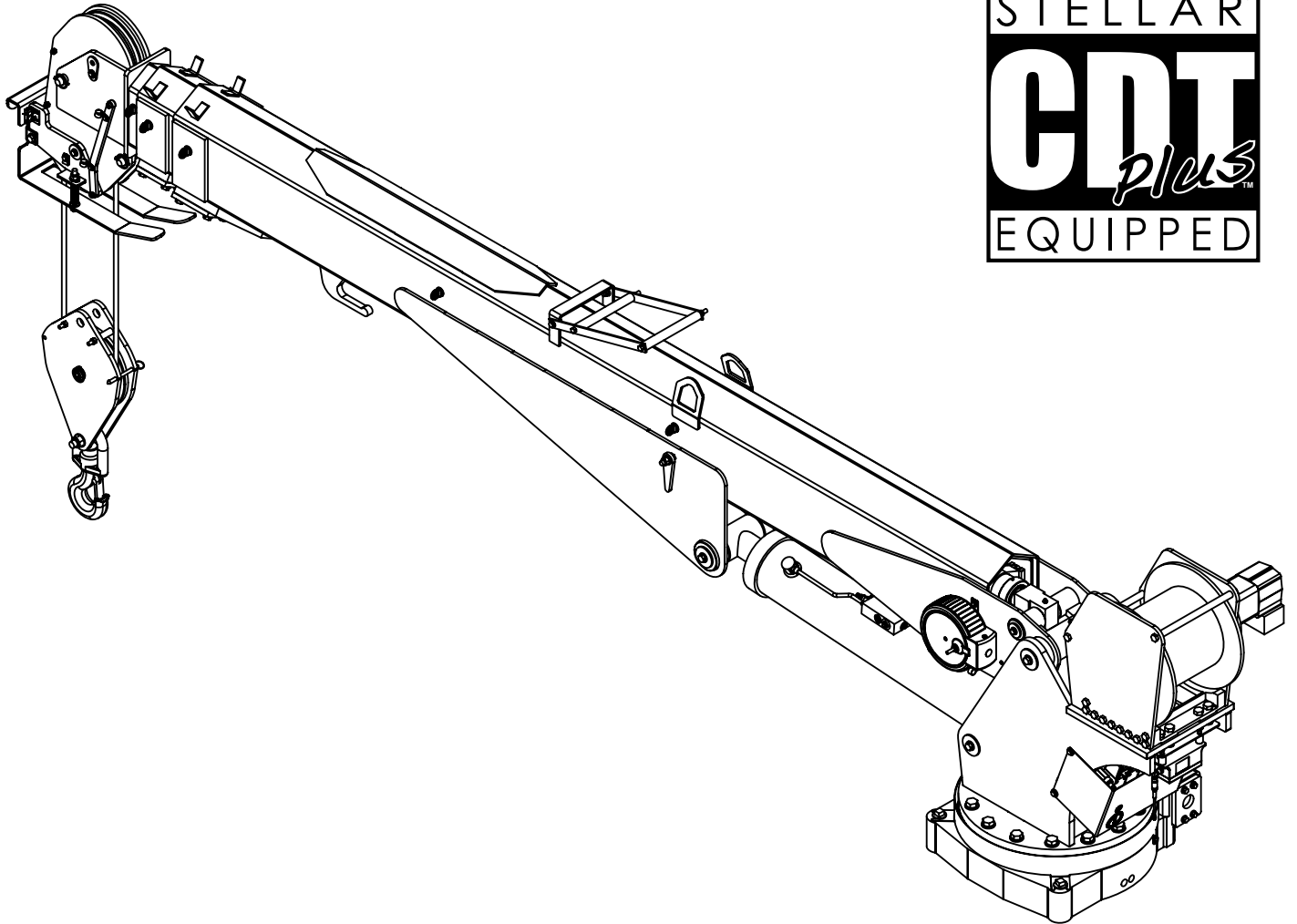

Model 14530 Telescopic Crane Owner's Manual

Installation • Assembly Drawings • Parts



Notice: A copy of this manual must remain with the equipment at all times.
For a printable download copy, please visit: www.stellarindustries.com

Stellar Industries, Inc.

190 State Street

PO Box 169

Garner, IA 50438

800-321-3741

Fax: 641-923-2811

www.stellarindustries.com

Subject to Change without Notification.
© 2016 Stellar Industries, Inc.

Last Revision: 10/27/16

Model 14530 Manual Revisions

Date of Revision	Section Revised	Description of Revision

**Serial Tag
Location**

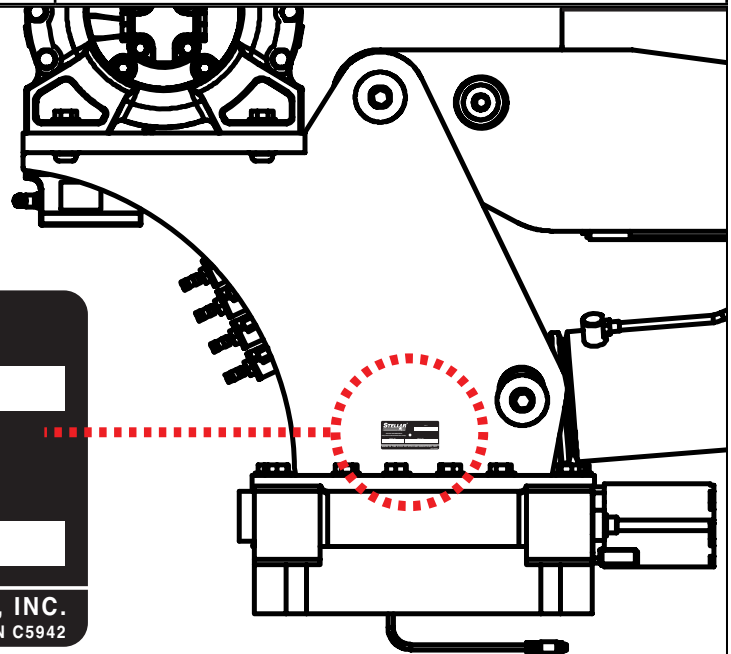
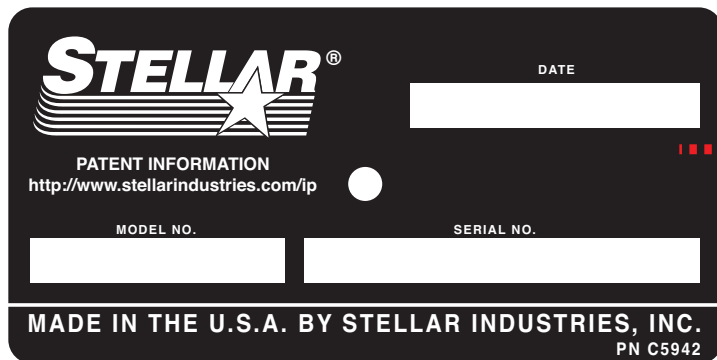

Table of Contents

Introduction	iv
Chapter 1 - Specifications.....	1
Model 14530 Specifications	1
Capacity Chart - Decal PN 71873	2
Dimensional Drawing 1	3
Dimensional Drawing 2.....	4
Chapter 2 - Installation	5
General Installation.....	5
Installer Notice	5
Torque Data Chart	6
Installation Overview	7
Control Kit - PN 74985	8
Electrical Circuit Grounding.....	9
Hydraulic Kit - PN 57573	10
Valve Bank - PN 57572	11
Hydraulic Installation.....	12
Winch Case Drain Installation.....	13
Hydraulic System	14
Face Seal/O-Ring Size Chart	15
Stability Procedure	16
Crane Load Level Indicator.....	17
Decal Kit - PN 71871	18
Chapter 3 - Assembly Drawings	19
Base Assembly - PN 26205.....	19
Mast Assembly - PN 74653.....	20
Main Boom Assembly - PN 74654	21
Extension Boom Assembly - PN 75099	22
Main Cylinder Assembly - PN 74655	23
Extension Cylinder Assembly - PN 72940.....	24
Cable & Hook Assembly - PN 56274	25

Introduction

A copy of this manual is provided with every crane and can be found in the hard plastic manual case that is installed on the chassis. A copy of this manual shall remain with the crane at all times.

Throughout the manual, three signal words will be used to bring attention to important items:

NOTICE

A NOTICE signal word indicates a practice not related to physical injury.

⚠ WARNING

A WARNING signal word indicates a hazardous situation which, if not avoided, could result in death or serious injury.

⚠ DANGER

A DANGER signal word indicates a hazardous situation which, if not avoided, will result in death or serious injury.

Information contained within this manual does not cover operation, maintenance, or troubleshooting. Please refer to the General Light Duty Crane Manual for details on these items.

This manual is not binding. Stellar Industries, Inc. reserves the right to change, at any time, any or all of the items, components, and parts deemed necessary for product improvement or commercial/production purposes. This right is kept with no requirement or obligation for immediate mandatory updating of this manual.

In closing:

If more information is required or technical assistance is needed, or if you feel that any part of this manual is unclear or incorrect, please contact the Stellar Customer Service Department by phone at 800-321-3741 or email at service@stellarindustries.com.

**For Technical Questions, Information, Parts, or Warranty, Call Toll-Free at
800-321-3741**

Hours: Monday - Friday, 8:00 a.m. - 5:00 p.m. CST

Or email at the following addresses:

Technical Questions, and Information

service@stellarindustries.com

Order Parts

parts@stellarindustries.com

Warranty Information

warranty@stellarindustries.com

Chapter 1 - Specifications

Model 14530 Specifications

Crane Rating*:	82,600 ft-lbs (11.42 TM)
Standard Boom Length:	13' 4" (4.06 m) from CL of Crane
Boom Extension:	1st Stage: Hydraulic 100" (254 cm) 2nd Stage: Hydraulic 100" (254 cm)
Maximum Horizontal Reach:	30' (9.14 m) from CL of Crane
Maximum Vertical Lift:	31' 9" (9.68 m) from Crane Base
Stowed Height (Crane Only):	43" (109.2 cm)
Required Mounting Space:	25" x 22" (63.5 cm x 55.9 cm)
Approximate Crane Weight:	14530 Standard 3,200 lbs (1,452 kg)
Controls:	Radio control standard for all functions.
Wire Rope:	1/2" (1.27 cm) 6X25 IWRC-DGXIP X 120' (36.58 m)
Boom Elevation:	-10° to +80°
Winch Specifications	
Line Pull Speed:	60 ft/min (18.29 m/min)
Max. Single Part Line:	7,000 lbs (3,175 kg)
Max. Double Part Line:	14,000 lbs (6,350 kg)
Rotation (Worm Gear):	400° Power
Lifting Capacity**:	14,000 lbs @ 5'10" (6,350 kg @ 1.78 m) 2,750 lbs @ 30' (1,247 kg @ 9.14 m)
Power Supply:	PTO & Pump: 12 gpm @ 2,600 psi (45.4 lpm @ 180 bar)

*Crane rating in Boost Mode. Normal crane rating is 70,000 ft-lbs (9.68 TM).

**Maximum capacities in Boost Mode.

Capacity Chart - Decal PN 71873

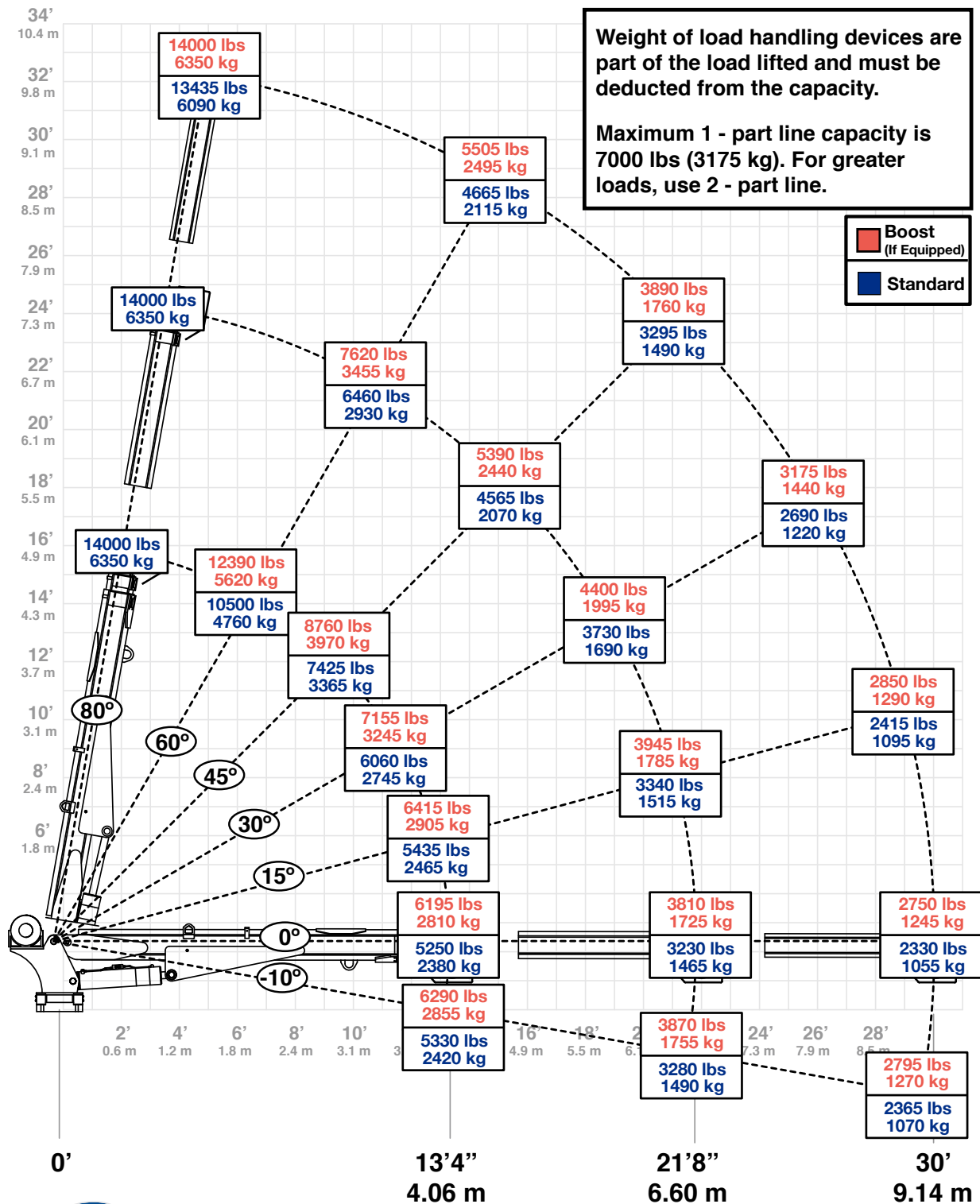

PN 71873 - Rev A

Dimensional Drawing 1

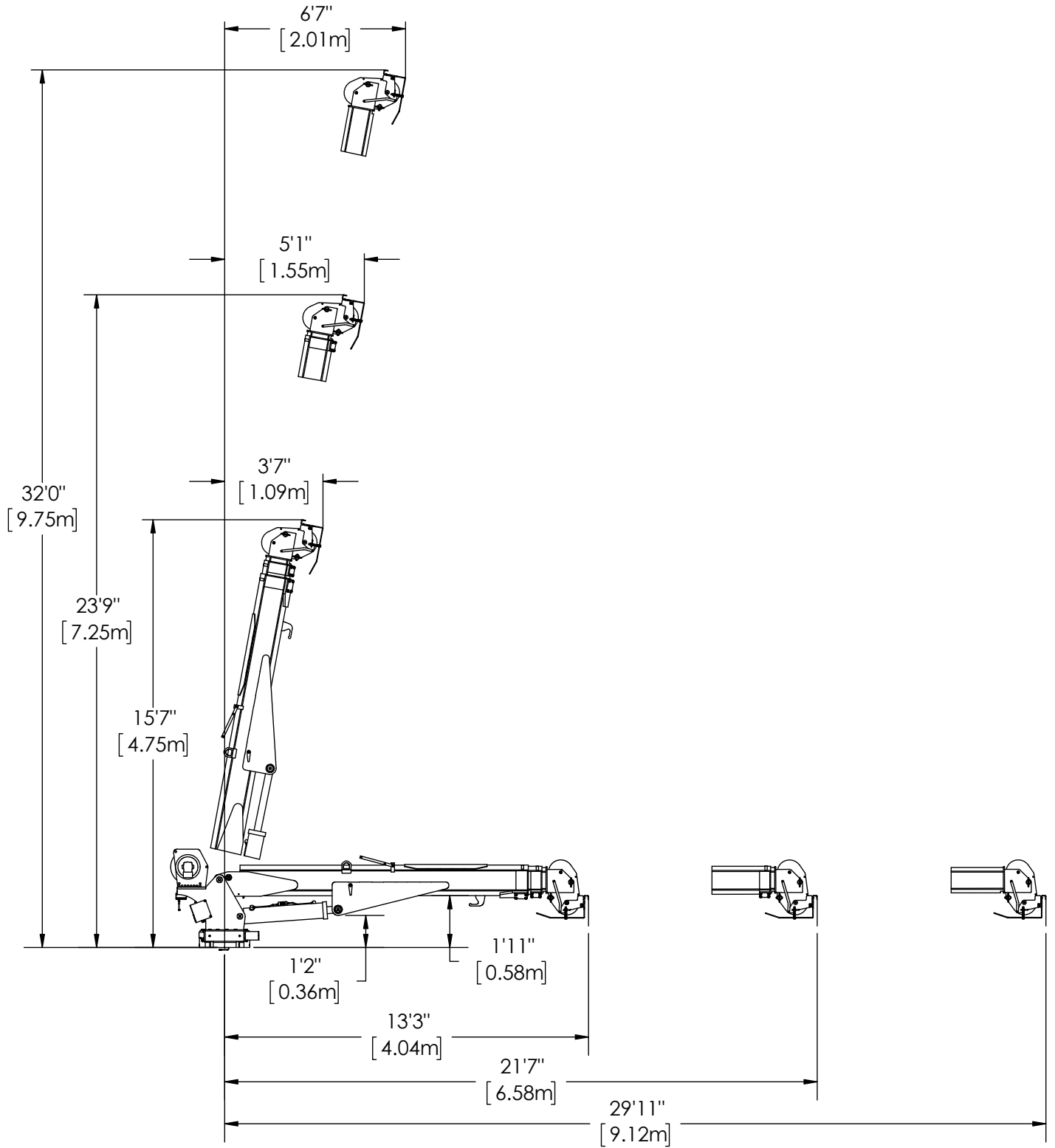

Dimensional Drawing 2

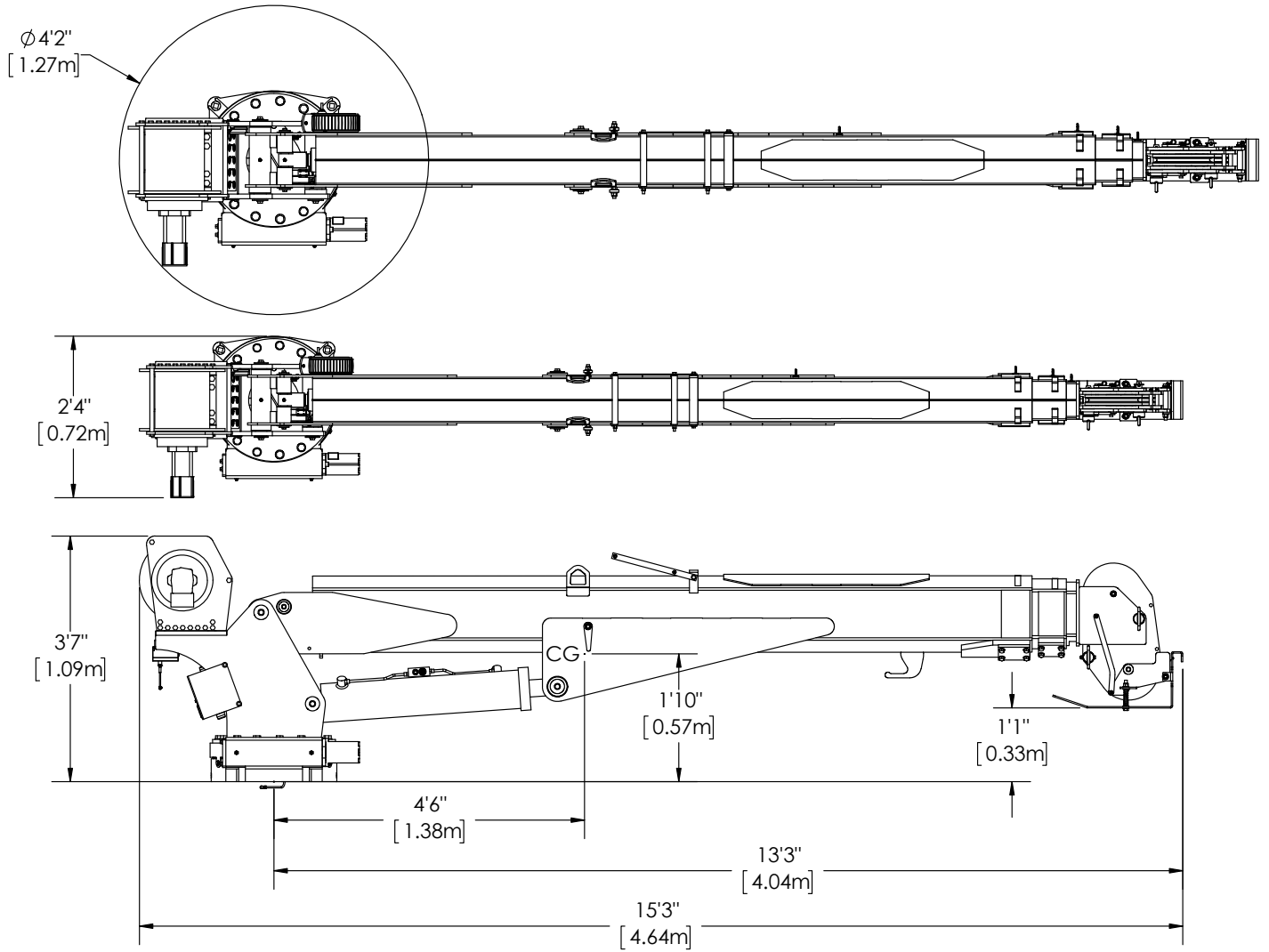

Chapter 2 - Installation

General Installation

This chapter is designed to serve as a general guide for the installation of a Stellar 14530 Crane on a Stellar Service Body. Each installation is considered unique so certain portions of this chapter may or may not apply to your direct application. If a question should arise during the installation process, please contact Stellar Customer Service at (800) 321 3741.

This crane is designed for use with a Stellar Service Body installed on a vehicle that meets the minimum chassis requirements of the crane. It is the installer's responsibility to assure that the crane is mounted on a platform that will support the maximum crane rating of this crane.

⚠ WARNING Do not install this crane on a body not capable of handling the loads imposed on it. Failure to do so may result in serious injury or death.

NOTICE When installing welder units to the service bodies, it is highly recommended that a surge protector is installed on the chassis batteries to protect the crane radio receiver, wiring and other electronic devices from an unexpected electrical spike or surge. Failure to do so could result in extensive damage to the service body and crane electrical circuit.

Installer Notice

According to Federal Law (49 cfr part 571), each final-stage manufacturer shall complete the vehicle in such a manner that it conforms to the standards in effect on the date of manufacture of the incomplete vehicle, the date of final completion, or a date between those two dates. This requirement shall, however, be superseded by any conflicting provisions of a standard that applies by its terms to vehicles manufactured in two or more stages.

Therefore, the installer of Stellar® Cranes and Bodies is considered one of the manufacturers of the vehicle. As such a manufacturer, the installer is responsible for compliance with all applicable federal and state regulations. They are required to certify that the vehicle is in compliance with the Federal Motor Vehicle Safety Standards and other regulations issued under the National Traffic and Motor Vehicle Safety Act.

Please reference the Code of Federal Regulations, title 49 - Transportation, Volume 5 (400-999), for further information, or visit <http://www.gpoaccess.gov/nara/index.html> for the full text of Code of Federal Regulations.

Torque Data Chart

When using the torque data in the chart, the following rules should be observed:

- Bolt manufacturer's particular specifications should be consulted when provided.

- Flat washers of equal strength must be used.

- All torque measurements are given in foot-pounds. To convert to inch-pounds, multiply by 12.

- Torque values specified are for bolts with residual oils or no special lubricants applied. If special lubricants of high stress ability, such as Never-Seez compound graphite and oil, molybdenum

disulphite, colloidal copper or white lead are applied, multiply the torque values in the charts by the factor .90. The use of Loctite does not affect the torque values listed above.

- Torque values for socket-head capscrews are the same as for Grade 8 capscrews.

- Do not use these values if a different torque value or tightening procedure is given for a specific application. Torque values listed are for general use only. Check tightness of fasteners periodically.

- Shear bolts are designed to fail under predetermined loads. Always replace shear bolts with identical grade.

- Fasteners should be replaced with the same or higher grade. If higher grade fasteners are used, these should only be tightened to the strength of the original.

- Tighten plastic insert or crimped steel-type lock nuts to approximately 110 percent of the dry torque values shown in the chart below, applied to the nut, not to the bolt head. Tighten toothed or serrated-type lock nuts to the full torque value. *Note: "Lubricated" means coated with a lubricant such as engine oil, or fasteners with phosphate and oil coatings. "Dry" means plain or zinc plated without lubrication. Tighten lubricated bolts to approximately 80% of dry bolts.*

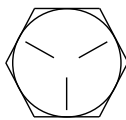
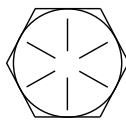
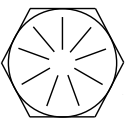
		GRADE 5		GRADE 8		GRADE 9
						
Size (DIA-TPI)	Bolt DIA (Inches)	Plain (Ft-Lb)	Plated (Ft-Lb)	Plain (Ft-Lb)	Plated (Ft-Lb)	Plated (Ft-Lb)
5/16-18	0.3125	17	13	25	18	22
3/8-16	0.3750	31	23	44	33	39
7/16-14	0.4375	49	37	70	52	63
1/2-13	0.5000	75	57	105	80	96
9/16-12	0.5625	110	82	155	115	139
5/8-11	0.6250	150	115	220	160	192
3/4-10	0.7500	265	200	375	280	340
7/8-9	0.8750	395	295	605	455	549
1-8	1.000	590	445	910	680	823
1 1/8-7	1.1250	795	595	1290	965	1167
1 1/4-7	1.2500	1120	840	1815	1360	1646
1 3/8-6	1.3750	1470	1100	2380	1780	2158
1 1/2-6	1.500	1950	1460	3160	2370	2865

Installation Overview

1. Determine that the mounting location for the 14530 crane is at least 25" x 22" (63.5 x 55.9 cm).
2. Use the detail below to drill 1.31" diameter holes into the mounting plate. Run tap on the threads of the base to be sure they are clean.
3. Use a crane or lifting device capable of lifting the weight of the Stellar® Crane. The Stellar 14530 weighs approximately 3100 lbs (1406 kg). **Note: cranes are shipped with rotation positioned at 200 degrees of 400 degree system.** This will allow for easy installation of the crane and permanent connection of all hydraulic and electrical components prior to repositioning into the crane saddle.
4. Connect straps or chain from the lifting device to the lifting rings on the 14530.
5. Use eight (8) 3.5" x 1.25" #8 bolts and eight (8) #8 flat washers.
6. Install a washer on each bolt.
7. Apply Loctite Thread locker #277 to the bolts.
8. Using the lifting device, lower the 14530 just above the crane compartment and start the bolts. Have someone assist in leveling the crane. **Note: the rotation motor should be to the door side of crane compartment and the boom should be extended back over the rear bumper.**
9. Secure the crane using the mounting hardware provided (see the detail below). **Note: longer or shorter cap screws may be required – recommended thread engagement into crane base is 1.75" – use grade 8, zinc plated cap screws only.**
10. Torque the cap screws to 950-1000 ft-lbs.
11. Remove supporting crane.
12. Hook-up hydraulics and electrical using the schematics provided in this chapter.

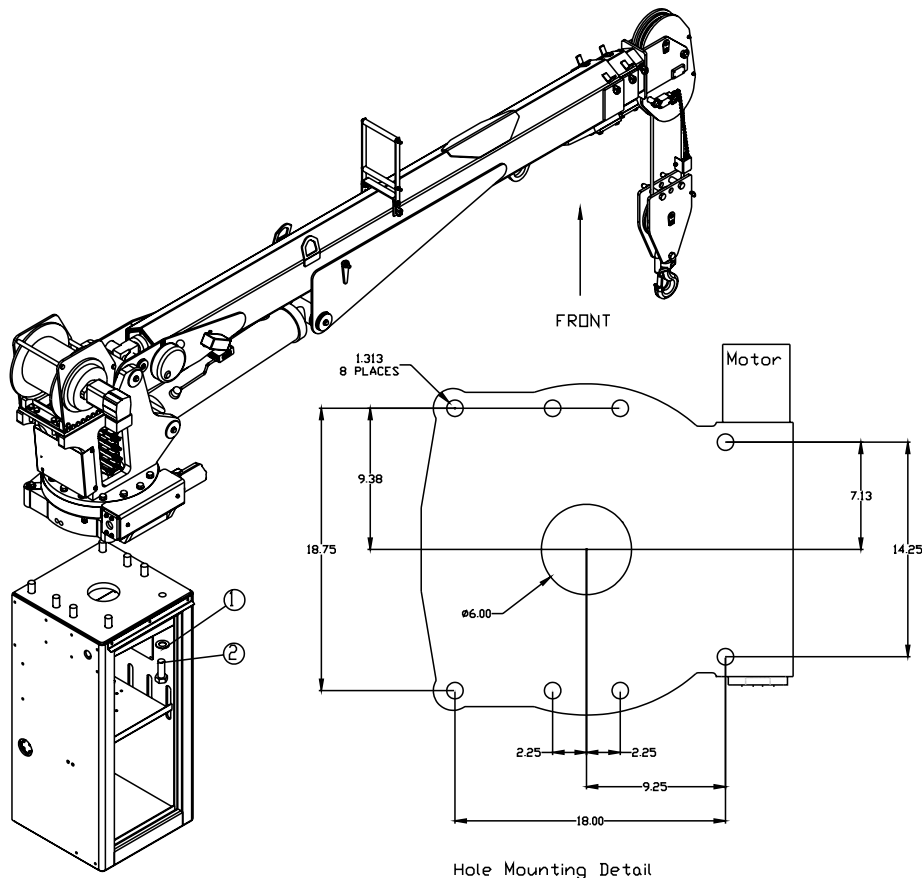

ITEM	PART	DESCRIPTION	QTY.
1	9180	WASHER 1.25 SAE FLAT YELLOW GR8	8
2	16654	CAP SCR 1.25-7X3.50 GR8	8

Control Kit - PN 74985

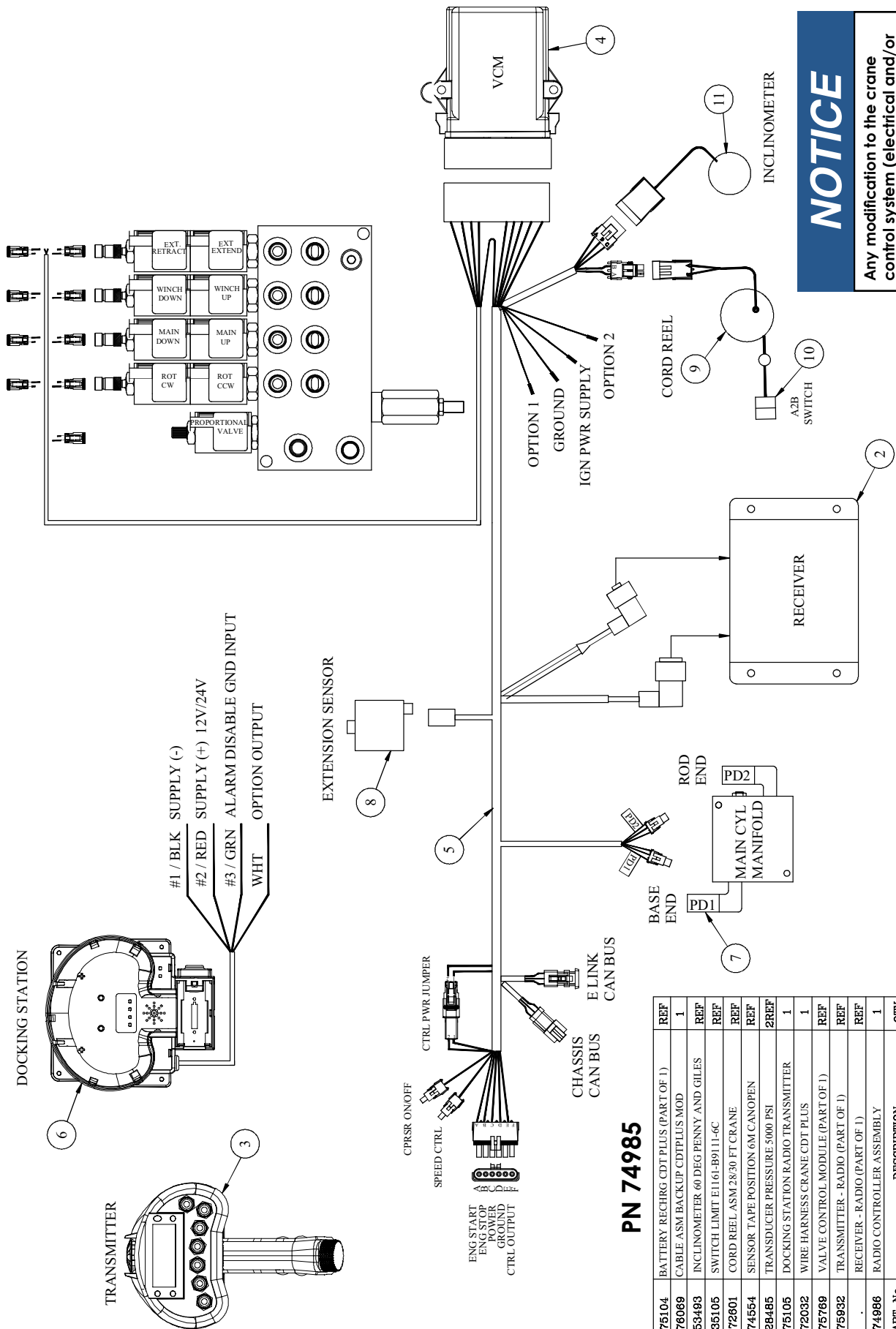

NOTICE
Any modification to the crane control system (electrical and/or hydraulic) must be approved by Stellar.

PN 74985

ITEM	PART No.	DESCRIPTION	QTY
13	75104	BATTERY RECHRG CDT PLUS (PART OF 1)	REF
12	76069	CABLE ASM BACKUP CDTPLUS MOD	1
11	53493	INCLINOMETER 60 DEG PENNY AND GILES	REF
10	35105	SWITCH LIMIT E116-B9111-6C	REF
09	72601	CORD REEL ASM 2830 FT CRANE	REF
08	74554	SENSOR TAPE POSITION 6M CANOPEN	REF
07	28485	TRANSDUCER PRESSURE 5000 PSI	2REF
06	75105	DOCKING STATION RADIO TRANSMITTER	1
05	72032	WIRE HARNESS CRANE CDT PLUS	1
04	75769	VALVE CONTROL MODULE (PART OF 1)	REF
03	75932	TRANSMITTER - RADIO (PART OF 1)	REF
02	.	RECEIVER - RADIO (PART OF 1)	REF
01	74986	RADIO CONTROLLER ASSEMBLY	1
		DESCRIPTION	QTY

Electrical Circuit Grounding

When installing the crane, always locate a good source for grounding the circuit. A majority of electrical failures are due to poor grounding. Poor grounding can cause intermittent operation of the equipment, electrical component failures and cause the equipment to not operate at all.

Chassis manufacturers usually will have a ground strap which ties into the truck frame from the battery, but it is always a good idea to check each individual model to verify where the ground is located. Never use the mechanic body as a ground source. Make sure the electrical grounds are routed to either the chassis frame rail or the chassis's main grounding source.

Stellar provides a stud (PN 40992) for grounding the crane to the chassis frame rail:



Inside Frame Rail



Outside Frame Rail

- **⚠ WARNING** Drill the hole to the frame rail in accordance with the chassis body builder's guide.
- **Hole size: 21/64"**
- The hole location should allow for the shortest length of ground wire while keeping enough slack for flexibility.
- Be sure to grind the frame rail around the hole to ensure a proper ground connection.
- Frame rail thickness may require additional flat washers (as shown).
- Use an electrical coating on hardware to prevent corrosion.

Hydraulic Kit - PN 57573

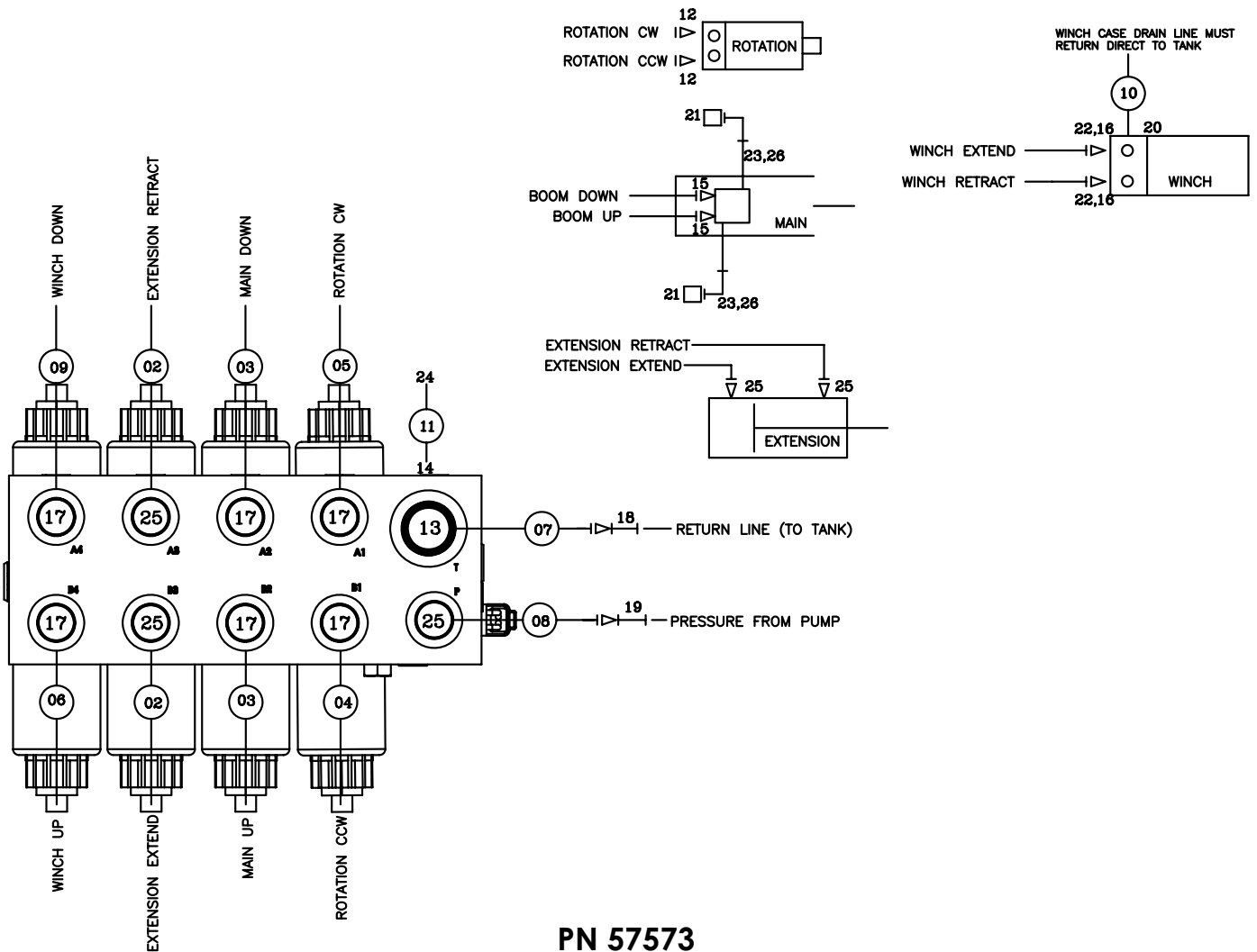

PN 57573

13	C2142	FTG ADAPT 12 F50LO-S	1	26	3861	FTG ML FM O'RING 90 DEG	2
12	D1302	FTG ST TH ELB 90 DEG 6-10 C50LO	2	25	1554	FTG ADAPT 8-F50LO-S	5
11	26016	HOSE-HYD .25X 15	1ref	24	25890	GAUGE OIL 0-5000 1/4 NPT TOU	1
10	59755	HOSE-HYD .38 X 64	1ref	23	15111	FTG ADAPT MSTH/FSTH 6-4-F50G5	2
09	59665	HOSE-HYD .38 X 26	1ref	22	C1180	FTG ADAPT 8-12 F50LO-S	2
08	59659	HOSE-HYD .50 X 24	1ref	21	28485	TRANSDUCER PRESSURE 5000 PSI	2
07	59660	HOSE-HYD .75 X 22	1ref	20	C4929	FTG ADAPT 6-4 F50LO-S	1
06	59666	HOSE-HYD .38 X 29	1ref	19	12172	FTG SWIVEL 0.50 FS/FS PS81 JMJM-8-8	1
05	59658	HOSE-HYD .38 X 44	1ref	18	28383	FTG SWIVEL 0.75 FS/FS PS81 JMJM-12-12	1
04	59532	HOSE-HYD .38 X 44	1ref	17	C1854	FTG ADAPT 6-8 F50LO-S	6
03	28385	HOSE-HYD .38 X 30	2ref	16	C2376	FTG ADAPT 8-C6LO-S	2
02	59531	HOSE-HYD .50 X 24	2ref	15	0279	FTG ADAPT 6 F50LO-S	2
01	57574	HOSE KIT,14528 CRANE (incl:2-11)	1	14	C1198	FTG ADAPT 90 4-C50LO-S	1
ITEM	PART No.	DESCRIPTION	QTY	ITEM	PART No.	DESCRIPTION	QTY

Valve Bank - PN 57572

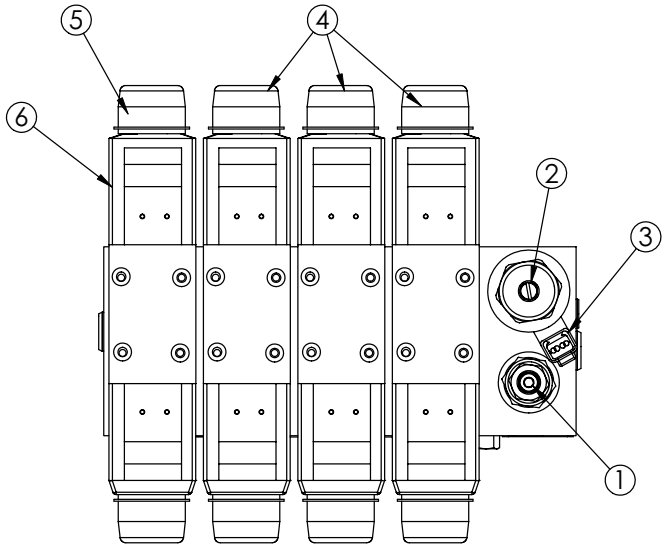
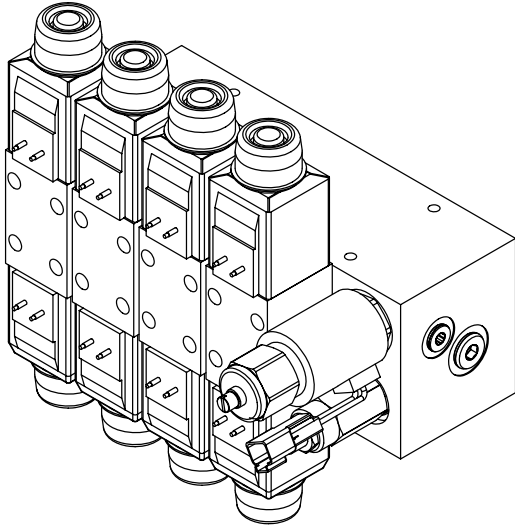

HYDRAULIC SCHEMATIC

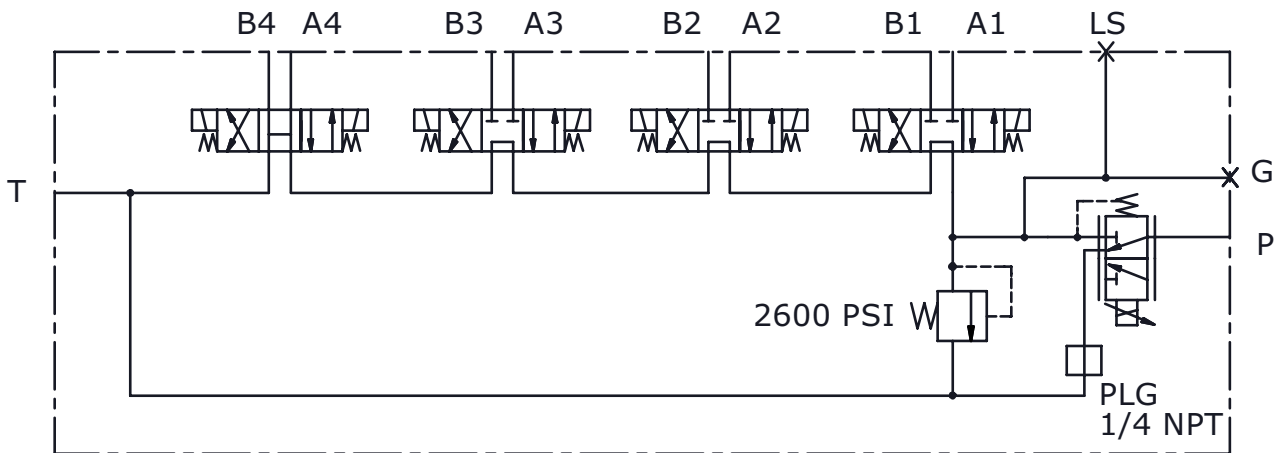

PN 57572

1	61059	VALVE RELIEF 14528 D03	1
2	61060	VALVE FLOW CTRL 14528 D03	1
3	61061	COIL FLOW CTRL 14528 D03	1
4	61062	VALVE TANDEM 14528 D03	3
5	61063	VALVE OPEN 14528 D03	1
6	61064	COIL VALVE 14528 D03	8

Hydraulic Installation

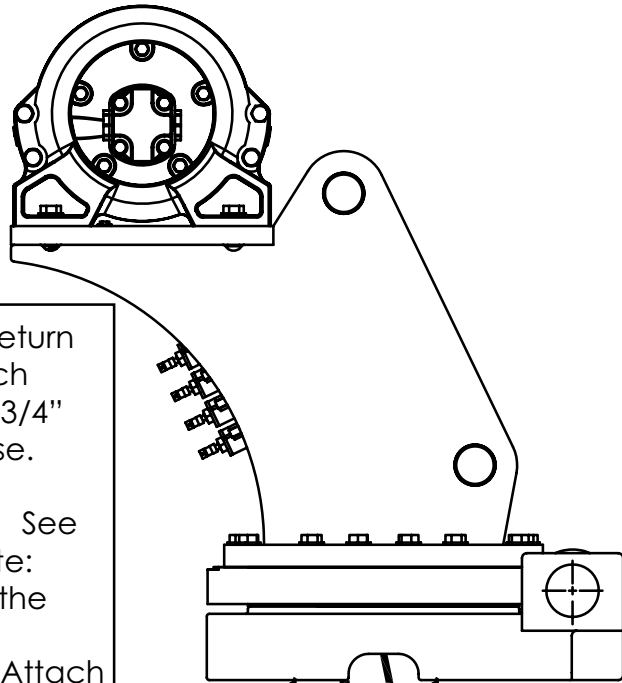

1. After mounting, locate the pressure and return lines. Note: Pressure line is 1/2" hose; Winch Case Drain Line is 3/8" hose; Return line is 3/4" hose; Optional Load Sense Line is 1/4" hose. Hoses are terminated using swivel fittings.
2. Install hydraulic lines per diagram below. See next page for Case Drain Installation. Note: Stabilizer valve supplies oil to crane using the Power Beyond feature.
3. Install hydraulic reservoir with return filter. Attach pump pressure line to valve, return link to tank.
4. Fill system with hydraulic oil (See Stellar® Lubrication Recommendations for fluid details).

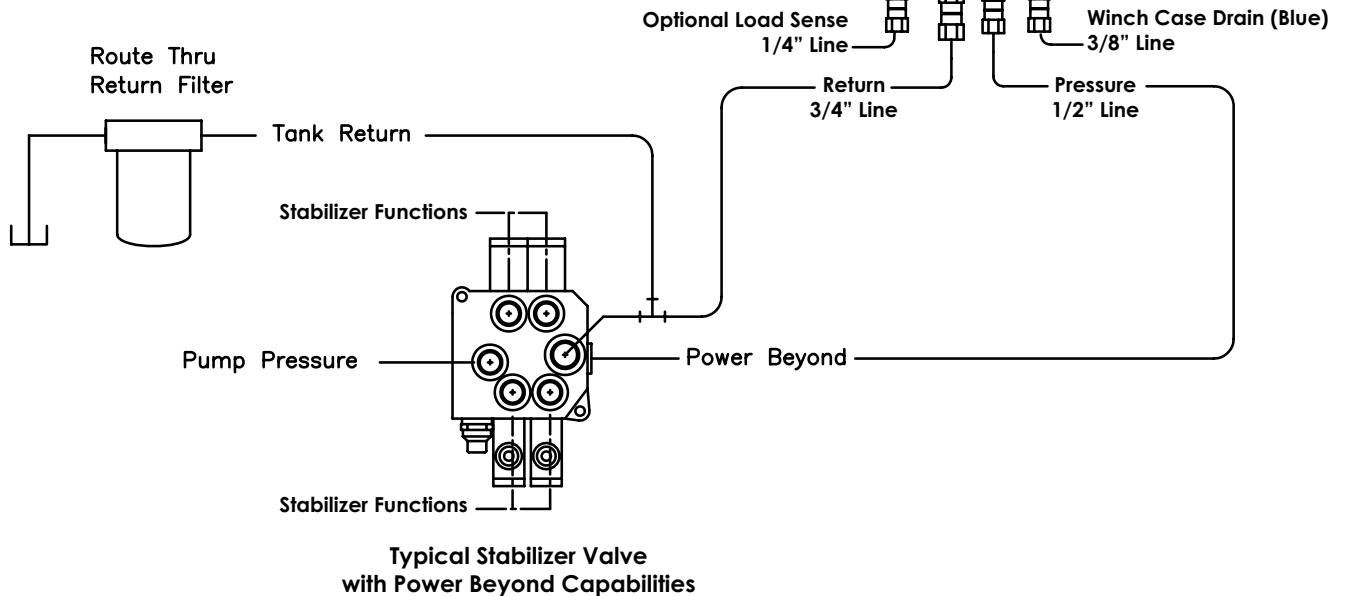

Winch Case Drain Installation

Installing the winch case drain

1. The winch case drain must run directly to the reservoir to ensure no back pressure in the line.
2. Use 3/8" hydraulic hose and fittings rated for a minimum of 300 psi.
3. Locate the winch case drain line at the bottom of the crane base as shown in Fig. 1 (Blue Hose).
Note: Both the main pressure and winch case drane line use a 3/8" swivel fitting. Verify the winch case drain is attached to the hose that is connected to the winch motor.
4. Attach one end of the winch case drain to 3/8 swivel fitting located in step 3.
5. Route the winch case drain hose directly to the reservoir.
6. Connect the second end of the winch case drain to unshared fitting on the top of the reservoir as shown in Fig 2.

Fig.1

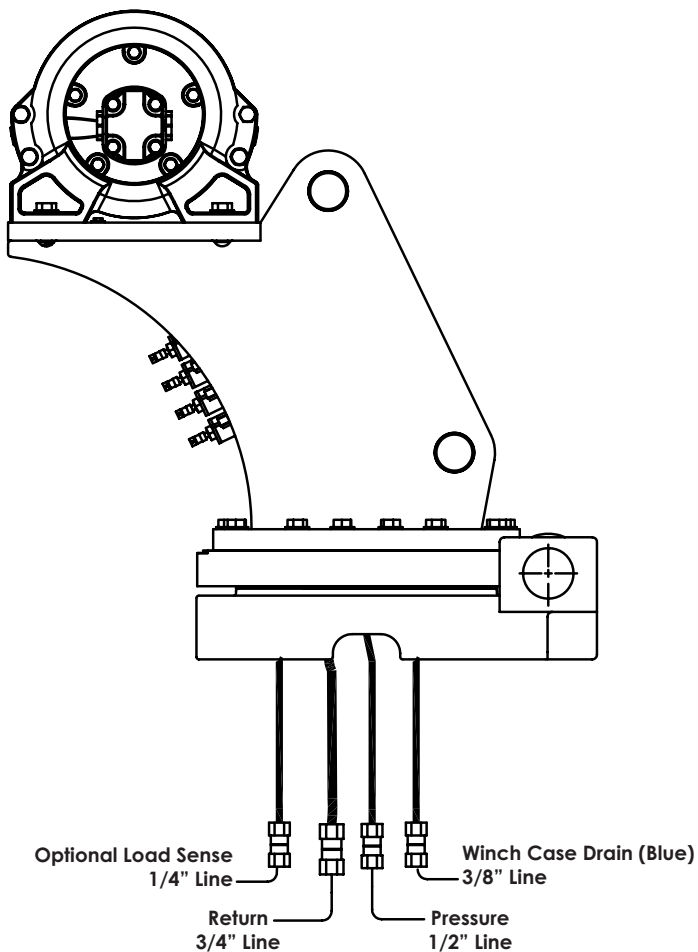
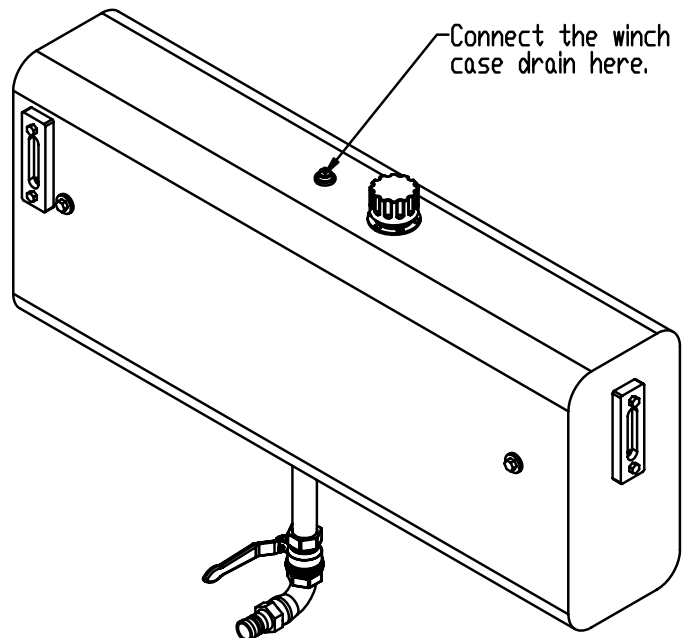
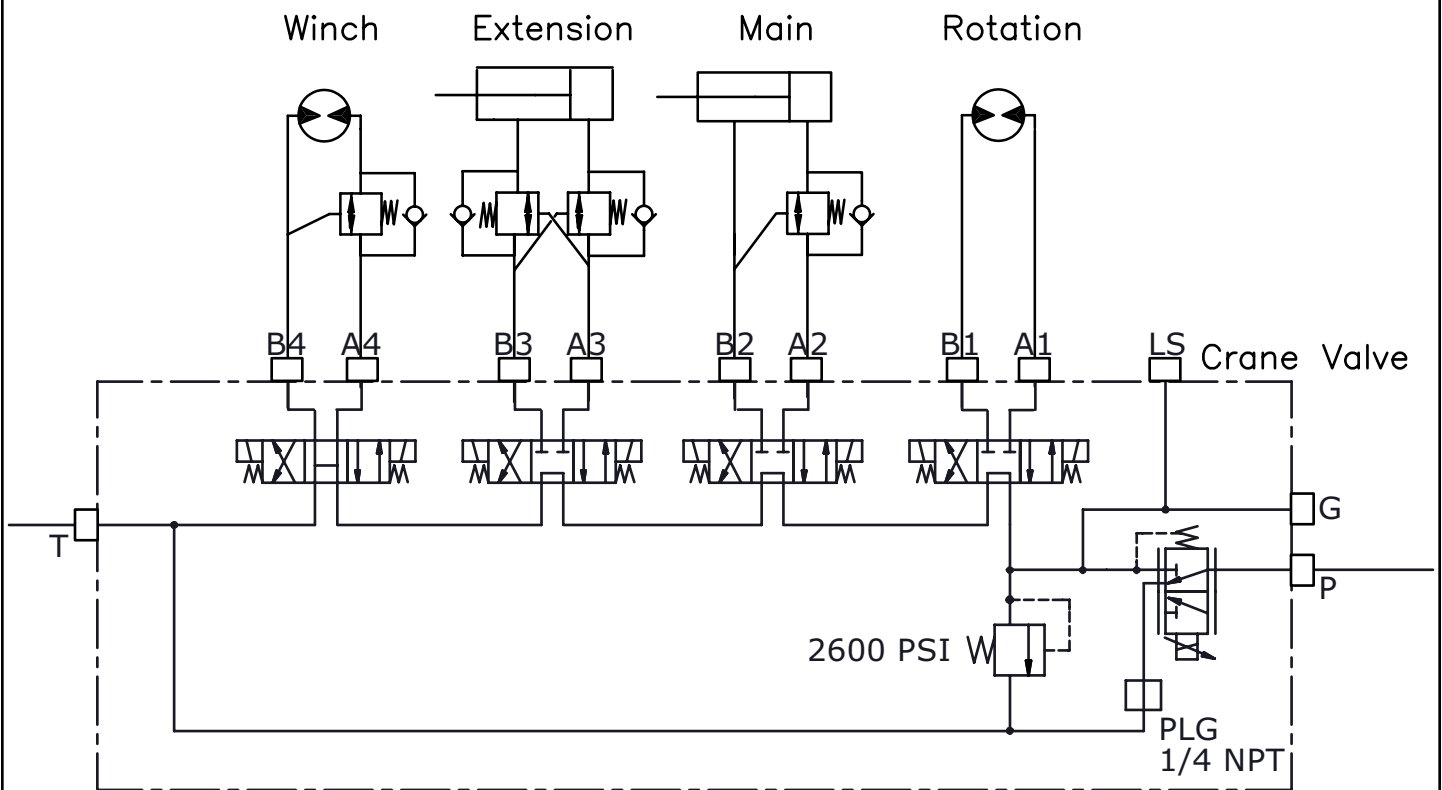

Fig. 2



Hydraulic System



Face Seal/O-Ring Size Chart

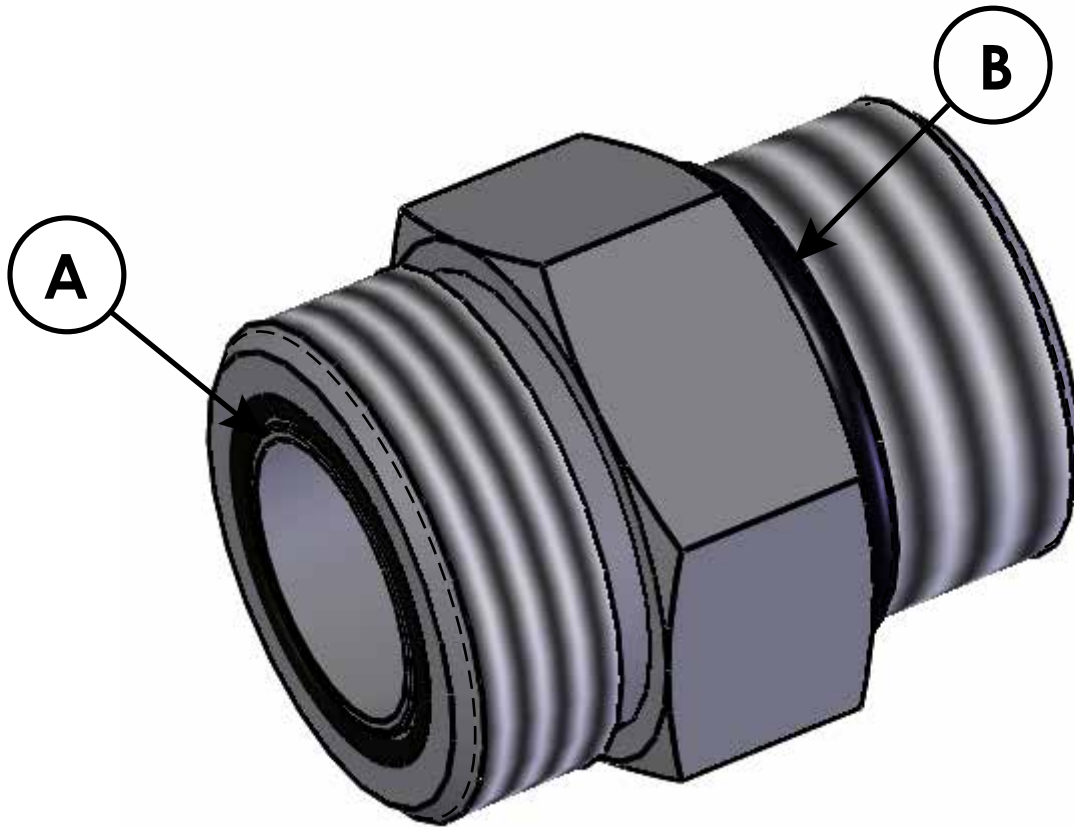

Hose Size	Fitting Size	Face Seal (A) Stellar® PN	O-ring Boss (B) Stellar® PN
1/4"	#4	C2027	D1245
3/8"	#6	C2028	D1246
1/2"	#8	C2029	D1247
5/8"	#10	32223	D1248
3/4"	#12	D1244	D1249
1"	#16		D1250

Stability Procedure

Definition of Stability for the Stellar Telescopic Crane Products:

A truck is stable until the load cannot be lifted off the ground with the winch, without tipping over the truck. Every Stellar crane installed must be tested for stability to determine the actual load capacity of the final truck package. The actual test data must be recorded and supplied with the truck at the time of in-service and should be kept with the truck at all times. The following procedure will test the truck package for stability and will provide a stability capacity chart. The load limit information shown on the stability capacity chart is formulated on 85% tipping.

Set Up:

1. Locate the truck on a test course in position for loading and engage travel brakes.
2. Set stabilizers so that they make contact with firm, level footing.
3. Operate the crane under partial load to assure operator proficiency and proper machine function.
4. Put the radio into Stability Test Mode:
 - A. Push the bottom four switches up and hold until all lights come on (approximately 5 seconds.)
 - B. At this point, the crane will have enough capacity to handle the weight for the stability test.



- C. The radio will timeout of stability mode after 30 minutes or when the E-Stop button is pushed.

Note: The radio can only be put into stability mode five times. After that, the radio would have to be returned to Stellar to be reprogrammed to allow additional stability testing. All other radio functions will work properly even if stability mode is not available.

Stability Procedure Continued...

14530 Stability Data

Max Horizontal Reach: 355" (From the center of rotation to boom tip)

Boost Stability Test Weight: 3,245 lbs.

Non-Boost Stability Test Weight: 2,750 lbs.

Test Procedure

1. Rotate the crane into Zone 1 position.
2. With the crane fully retracted and the boom horizontal, winch the test weight off the ground. Note: Keep weight within six inches of the ground at all times.
3. Extend the boom outward until full extension has been reached or until the truck becomes unstable (Again, use the winch to keep the weight within six inches of the ground.)
4. If the boom goes full extension without becoming unstable, the crane is termed stable for this zone and 100% can be written in the Zone 1 data box.
5. If the truck becomes unstable prior to going full extension, retract the boom until the truck becomes stable and measure the horizontal reach in this position (center of rotation to boom tip). This is the stable horizontal reach for this zone. Stable horizontal reach divided by Maximum horizontal reach multiplied by 100 equals the percentage of rated capacity for this zone. Use the following formula to determine the percentage of rated capacity:

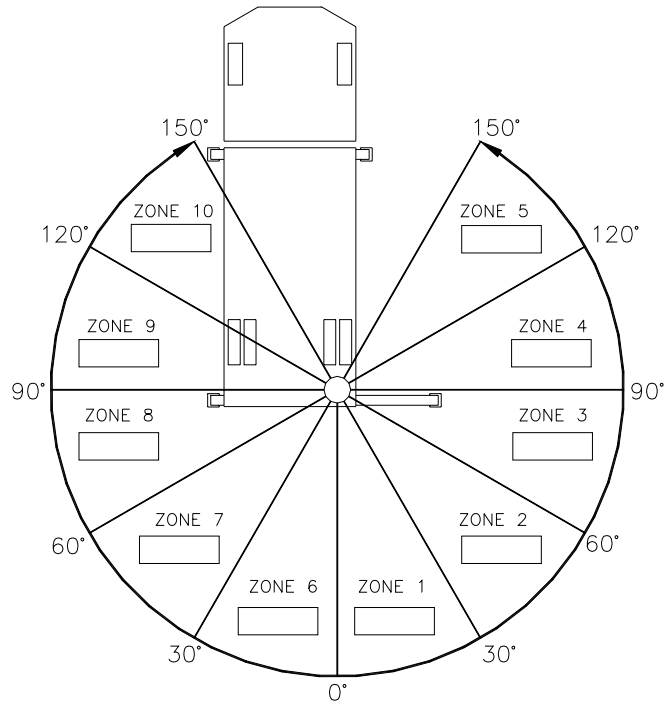

$$\frac{\text{Stable Horizontal Reach}}{\text{Max Horizontal Reach}} \times 100 = \text{Percentage of Rated Capacity}$$

6. Record this number in the data box for Zone 1. This is the revised capacity due to stability for this zone.
7. Repeat this procedure for each zone until the worksheet is completed.
8. This is the revised capacity based on stability of this package.

Crane Load Level Indicator

Stellar® Cranes are shipped with a load level indicator that is used to determine if the truck is level (side to side) before using the crane to pick/move a load. This level should be installed in the isolated crane compartment of the body. If level indicator is missing or damaged, please contact Stellar Customer Support for a replacement.



PN 76483

Decal Kit - PN 71871

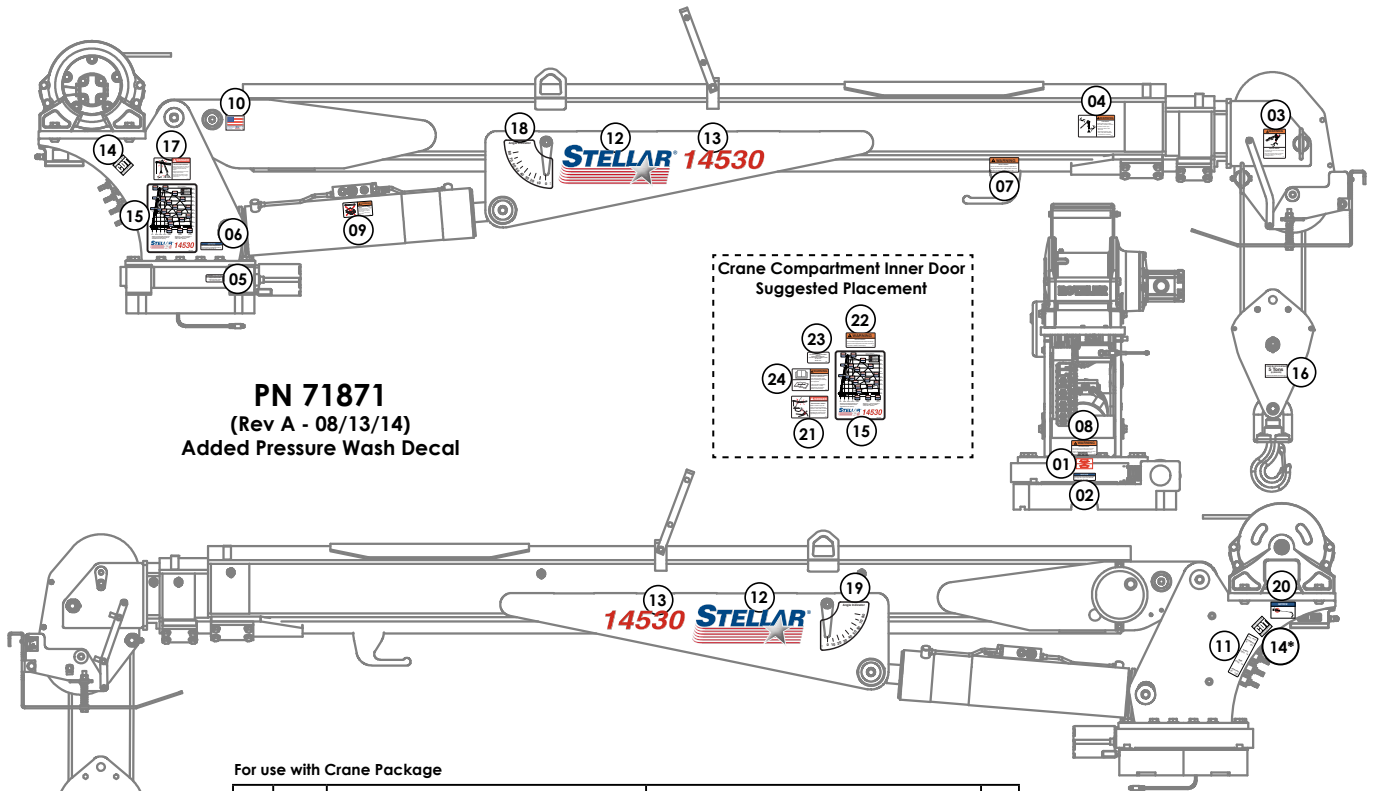

PN 71871
(Rev A - 08/13/14)
Added Pressure Wash Decal

For use with Crane Package

ITEM	PN	DESCRIPTION	LOCATION	QTY
01	4188	DECAL ROTATION ALIGNMENT	Crane Base	1
02	9188	DECAL ROTATE/GREASE	Crane Base	1
03	12300	DECAL WARNING TWO BLOCKING	Crane Horse Head	1
04	12451	DECAL WARNING HOISTING PERSONNEL	Main Boom	1
05	15171	DECAL GREASE WORM	Crane Base	1
06	15172	DECAL ASME/ANSI B30.22/B30.5	Crane Mast	1
07	24712	DECAL WARNING STOW HOOK	Crane Boom above stow hook	1
08	25159	DECAL WARNING MANUAL OVERRIDES	Under Valve Bank	1
09	28256	DECAL WARNING OVERLOAD DEVICE	Main Cylinder	1
10	35234	DECAL STELLAR MADE IN THE USA	Main Boom	1
11	52270	DECAL VB CONTROL MECH CRANE	On side of Crane Mast	1
12	52681	DECAL STELLAR LOGO 6.5 X 18	Main Boom (Both Sides)	2
13	71872	DECAL IDENTIFICATION 14530	Main Boom (Both Sides)	2
14*	54588	DECAL CDT 2.00 x 2.00	CDT ONLY - Crane Mast (Both Sides)	2
14*	71895	DECAL CDT PLUS 2.00 x 2.00	CDT PLUS ONLY - Crane Mast (Both Sides)	2
15	71873	DECAL CAPACITY 14530	Main Boom and Crane Compartment	2
16	56486	DECAL SNATCH BLOCK 7 TON	Snatch Block	1
17	C1179	DECAL DANGER ELECTROCUTION SMALL	Crane Mast	1
18	D1196	DECAL ANGLE INDICATOR CS	Main Boom	1
19	D1197	DECAL ANGLE INDICATOR SS	Main Boom	1
20	73929	DECAL PRESSURE WASH	Crane Mast	1

For use with Body/Chassis Package

ITEM	PN	DESCRIPTION	LOCATION	QTY
21	4186	DECAL DANGER ELECTROCUTION REMOTE	Crane Compartment	1
22	4189	DECAL WARNING OVERLOAD	Crane Compartment	1
23	4214	DECAL SERVICE	Crane Compartment	1
24	68024	DECAL WARNING UNTRAINED OPERATOR	Crane Compartment	1
25**	C4545	DECAL DANGER ELECTROCUTION LARGE	Four corners of the body/chassis	4
26**	C5910	DECAL STELLAR 4x9.5	Suggested: Rear body/tailgate	1
27**	C5911	DECAL STELLAR 2x4.5	Suggested: Side corners of body	3

* For CDT™ equipped cranes, use PN 54588. For CDTplus™ equipped cranes, use PN 71895.

** Not shown.

Chapter 3 - Assembly Drawings

Base Assembly - PN 26205

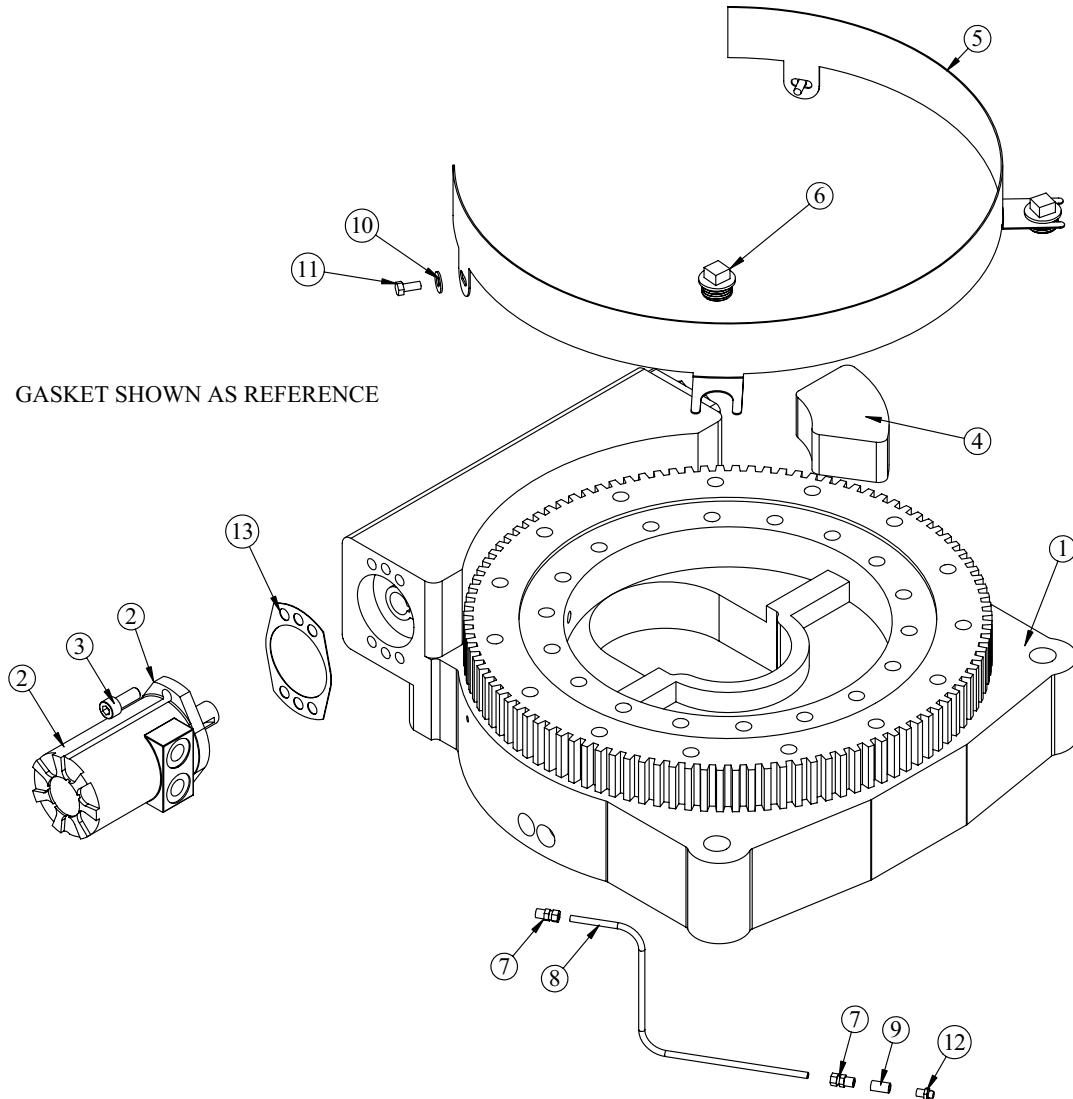

PN 26205

ITEM	PART	DESCRIPTION	QTY.
1	25140	BEARING SWING DRIVE CAST BASE 14528	1
2	26206P	MOTOR HYD ROSS MK080613AAAAB	1
3	D1307	CAP SCR 0.50-13X1.25 SHGR8 W/ RED PATCH	2
4	26207	STOP 14528 400 SLIDE	1
5	44554	GUARD TTB 14528 CRANE LZR	1
6	26774	CAP SCR 1.25-7X0.63 PLASTIC	2
7	D1345	FTG CPRSN 0.12NPT/0.25 TUBE	2
8	D1810	TBE AIR SAEJ844 TYPE A .25 (RM)	2.5
9	22161	FTG 2-2 FP-FP COUPLER STRAIGHT BRASS	1
10	0343	WASHER 0.31 USS FLAT ZINC	2
11	0420	CAP SCR 0.31-18X0.75 HHGR5	2
12	56589	ZERK 1/8 NPT STRAIGHT LONG THREAD	1
13	21151	GASKET MOTOR 008-10056-1	1

Mast Assembly - PN 74653

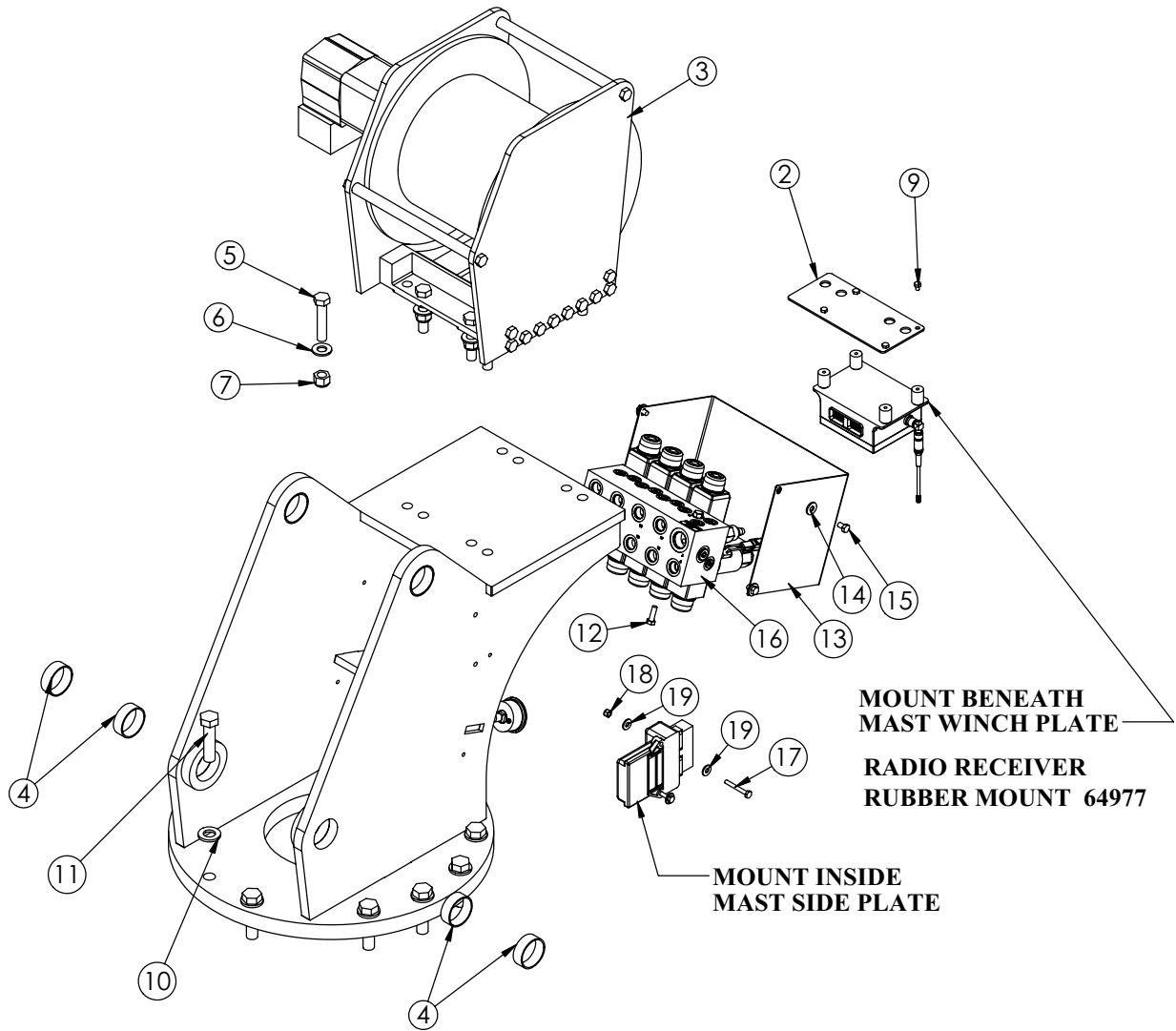

PN 74653

ITEM	PART	DESCRIPTION	QTY.
1	71867	MAST 14530	1
2	53199	ADAPTER PLATE RADIO 6 FCTN LMI 14528	1
3	26775	WINCH 7000 TULSA 707W	1
4	44533	BUSHING COMPOSITE MRP 2.00X0.75	6
5	D1034	CAP SCR 0.63-11X3.00 HHGR8 W/RED PATCH	8
6	C5902	WASHER 0.63 SAE FLAT YELLOW GR8	8
7	24868	NUT 0.63-11 HHGR8 NYLOC	8
8	53067	NUT 0.63-11 JAM NYLOC	2
9	56165	CAP SCR 6MMX8MM HH 8.8(GR5)	4
10	C6219	WASHER 0.75 SAE FLAT YELLOW GR8	13
11	C1028	CAP SCR 0.75-10X3.00 HHGR8	13
12	C0922	CAP SCR 0.31-18X1.00 HHGR5	4
13	56661PC	COVER VB 14528	1
14	0343	WASHER 0.31 USS FLAT	4
15	0484	CAP SCR 0.31-18X0.50 HHGR5	4
16	57572	VB 4 EATON D03 14528	1
17	0481	CAP SCR 0.25-20X2.00 HHGR5	2
18	0333	NUT 0.25-20 HHGR5 NYLOC	2
19	0340	WASHER 0.25 USS FLAT	4

Main Boom Assembly - PN 74654

-TWO WASHERS BETWEEN SENSOR AND PLATE
-NO WASHER BETWEEN BOLT AND PLATE

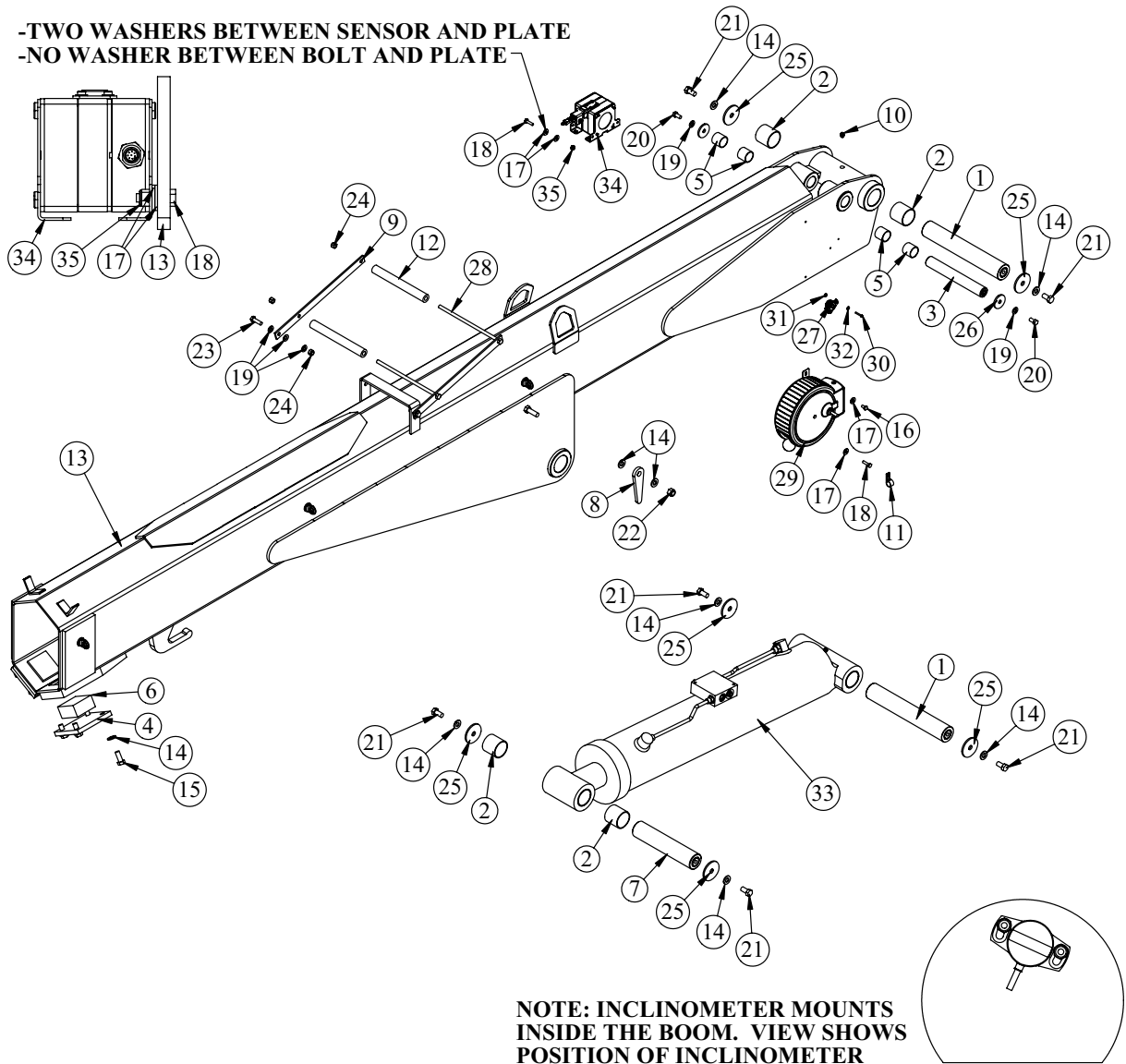

PN 74654

ITEM	PART	DESCRIPTION	QTY.
1	13364CR	PIN 2.00X12.69 D&T	2
2	4381	BUSHING 32DXR32 2.00X2.00 GARLOCK	4
3	26214CR	PIN 1.25X9.19 D&T	1
4	26751	PLATE WEAR PAD SUPPORT 14528	2
5	0249	BUSHING BPC-2022-20 1.25X1.25	4
6	26215	WEAR PAD 3.00X3.00X1.50	2
7	26213CR	PIN 2.00X9.63 D&T	1
8	D1194	PLATE ANGLE INDICATOR	2
9	26752PC	BRKT ROPE GUIDE 14528	2
10	c1592	ZERK 1/8 NPT STRAIGHT	1
11	C0078	CLAMP 0.38 BLK VINYL	1
12	26753	SPACER ROPE GUIDE 14528 UHMW	2
13	71868	INNER BOOM 14530	1
14	D0790	WASHER 0.50 SAE FLAT YELLOW GR8	18
15	10666	CAP SCR 0.50-13X1.25 HHGR8	8
16	0478	CAP SCR 0.25-20X0.50 HHGR5	1
17	0340	WASHER 0.25 USS FLAT	6
18	0480	CAP SCR 0.25-20X1.00 HHGR5	3
19	C6353	WASHER 0.38 SAE FLAT YELLOW GR8	8
20	9843	CAP SCR 0.38-16X0.75 HHGR8	2

ITEM	PART	DESCRIPTION	QTY.
21	10172	CAP SCR 0.50-13X1.00 HHGR8	6
22	C6106	NUT 0.50-13 HHGR5 NYLOC	2
23	0335	CAP SCR 0.38-16X1.25 HHGR5	2
24	0347	NUT 0.38-16 HHGR5 NYLOC	4
25	9142	PIN CAP 0.56X2.50X0.19 YZ	6
26	9320	PIN CAP 0.44X1.75X0.19 YZ	2
27	53493	INCLINOMETER 60 DEG	1
28	26755	CAP SCR 0.38-16X10.00 HHGR5	2
29	72601	CORD REEL ASM 30 FT CRANE	1
30	18618	SCREW #6-32X1.00 PHMS PH	2
31	D0076	NUT #6-32 HH NYLOC SS	2
32	18765	WASHER #6 SAE FLAT	2
33	74655	CYLINDER ASM 14530 CDT PLUS	1
34	74554	SENSOR TAPE POSITION 6M CANOPEN	1
35	0333	NUT 0.25-20 HHGR5 NYLOC	2

Extension Boom Assembly - PN 75099

PN 75099

ITEM	PART	DESCRIPTION	QTY.
1	9991	WEAR PAD 0.19X2.50 RND NYLATRON	4
2	24557	SHEAVE 14528 10.00 DIA .50R/1.94 THK	2
3	27719	SPACER BOOM TIP 6620 UHMW	2
4	26758	WEAR PAD 2.50X2.50X1.50 NYLATRON	2
5	26759PC	PLATE WEAR PAD SUPPORT 14528	2
6	12824	PIN HITCH 1.00X4.50	1
7	5753	PIN 0.19X1.56 LYNCH	2
8	D0178	WASHER #10 SAE FLAT	2
9	D0790	WASHER 0.50 SAE FLAT YELLOW GR8	18
10	0343	WASHER 0.31 USS FLAT	2
11	C6219	WASHER 0.75 SAE FLAT YELLOW GR8	1
13	35105	SWITCH LIMIT E1117-B9111-6C	1
13	27710	SPRING ANTI 2 BLOCK CRADLE A2B	2
14	31279	CLAMP 0.31 BLK VINYL	1
15	31132	CAP SCR #10-24X0.550 SH SS 18-8	2
16	C1000	CAP SCR 0.50-13X5.00 HHGR5	2
17	0484	CAP SCR 0.31-18X0.50 HHGR5	1
18	0490	CAP SCR 0.31-18X3.50 HHGR5	2
19	4974	CAP SCR 0.75-10X2.50 HHGR8 W/RED PATCH	1
20	10666	CAP SCR 0.50-13X1.25 HHGR8	8
21	C6106	NUT 0.50-13 HHGR5 NYLOC	3
22	0342	NUT 0.31-18 HHGR5 NYLOC	3
23	71869	EXT BOOM 1ST 14530	1
24	71870	EXT BOOM 2ND 14530 FS/CRADLE A2B	1
25	61838PC	PLATE SHEAVE MOUNTING 14528	2
26	13400ZP	PIN TEAR DROP 1.00X4.38	1
27	45125	PIN HITCH 1.00 FORK KPCC	1
28	61549PC	COLLAR 1.13X2.00X1.13 W/HOLE	1
29	0489	CAP SCR 0.31-18X2.50 HHGR5	1
30	0420	CAP SCR 0.31-18X0.75 HHGR5	1
31	61837	LINK FS/CRADLE A2B 14528 W/HOLES	1
32	C6353	WASHER 0.38 SAE FLAT YELLOW GR8	6
33	61053	BOLT SHOULDER 0.38X0.50 0.31-18X0.50	4
34	0478	CAP SCR 0.25-20X0.50 HHGR5	2
35	0340	WASHER 0.25 USS FLAT	2
36	C0078	CLAMP 0.38 BLK VINYL	2
37	66270	LINK FS/CRADLE A2B 14528	1
38	61054	MNT CRADLE RH FS/CRADLE A2B 106/126	1
39	61051	MNT CRADLE LH FS/CRADLE A2B 106/126	1
40	61048	CRADLE FS/CRADLE A2B 106/126	1
41	C1002	CAP SCR 0.50-13X6.00 HHGR5	1
42	37680ZP	PIN 1.00X4.19 SR	1
43	9320	PIN CAP 0.56X3.50X.25	2
44	9843	CAP SCR 0.38-16X0.75 HHGR8	2
45	61548PC	PIPE 0.50X 3.13 SCH40	1
46	72940	CYLINDER EXT ASM 14530	1
47	75094	J-BOLT W/NUT 8-32X1.88	1
48	75813	TAPE UHMW 0.020X1.00(RM)	0.17

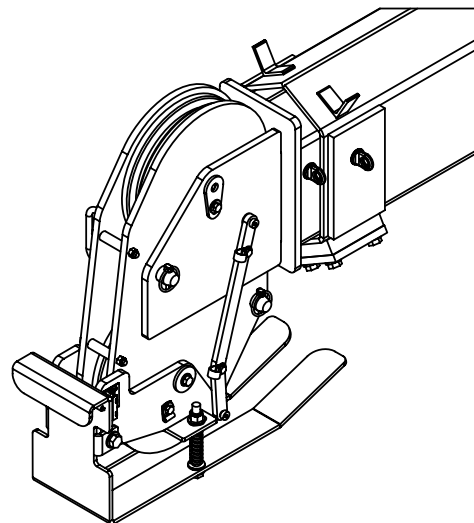
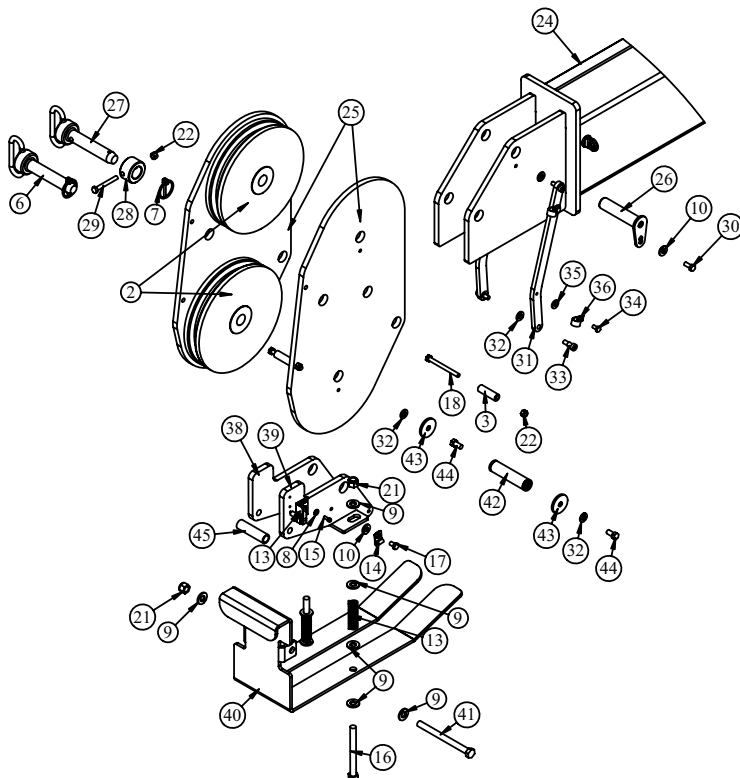
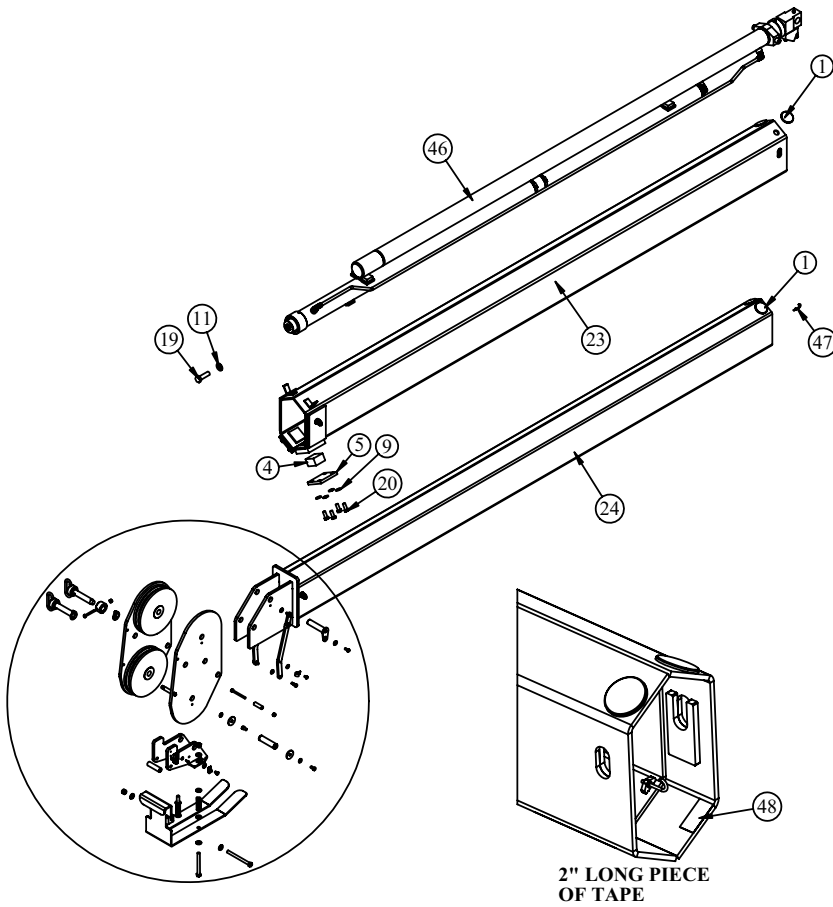

Main Cylinder Assembly - PN 74655

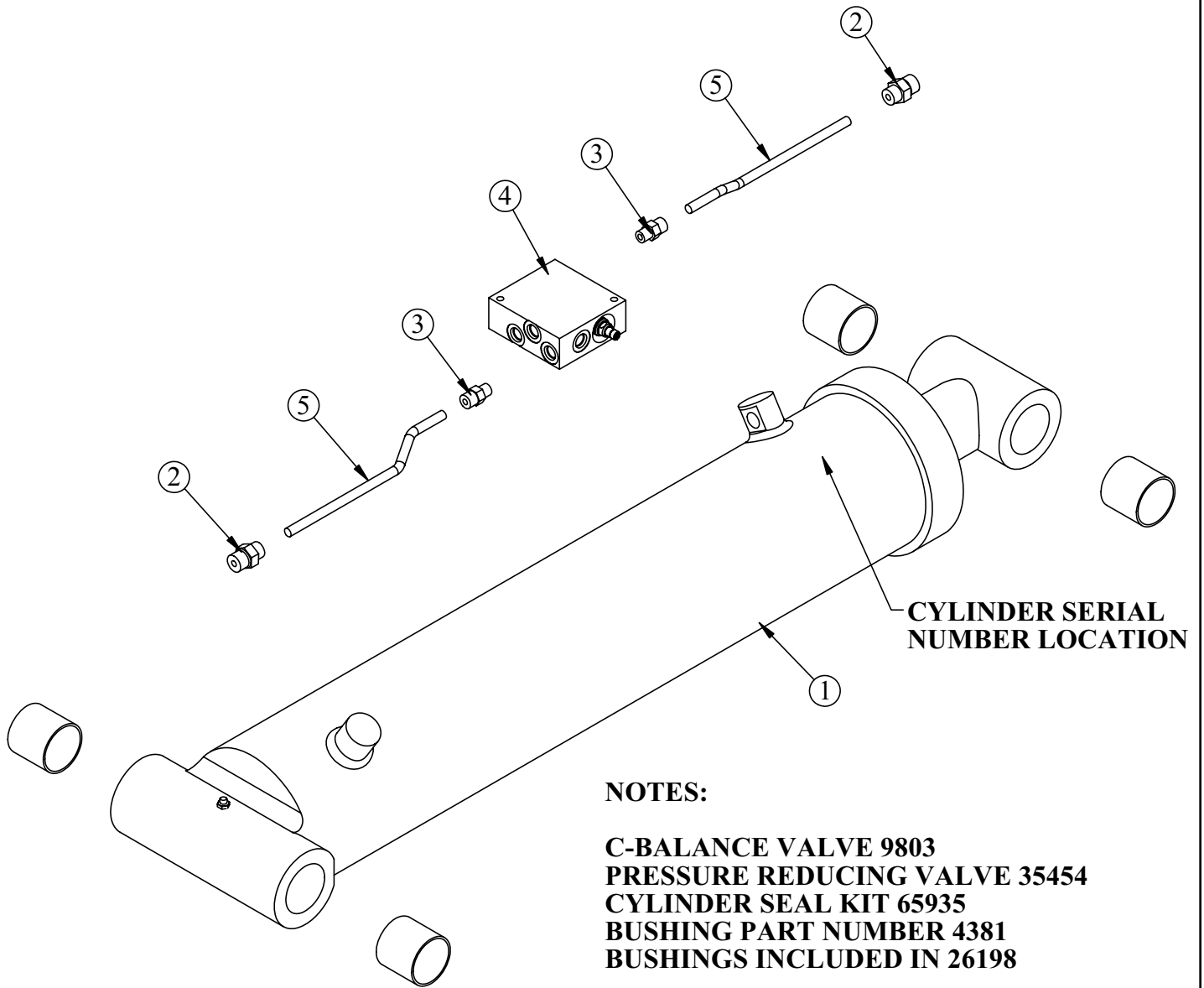

PN 74655

ITEM	PART	DESCRIPTION	QTY.
1	26198	CYLINDER INNER 6.00X25.75	1
2	C1854	FTG 6-8 MFS-MORB STRAIGHT	2
3	0279	FTG 6-6 MFS-MORB STRAIGHT	2
4	13080	MANIFOLD SINGLE T11A 3500 PSI	1
5	26212	TUBE ASM 0.38X9.63 MAIN CYL 6620 YZ	2

Extension Cylinder Assembly - PN 72940

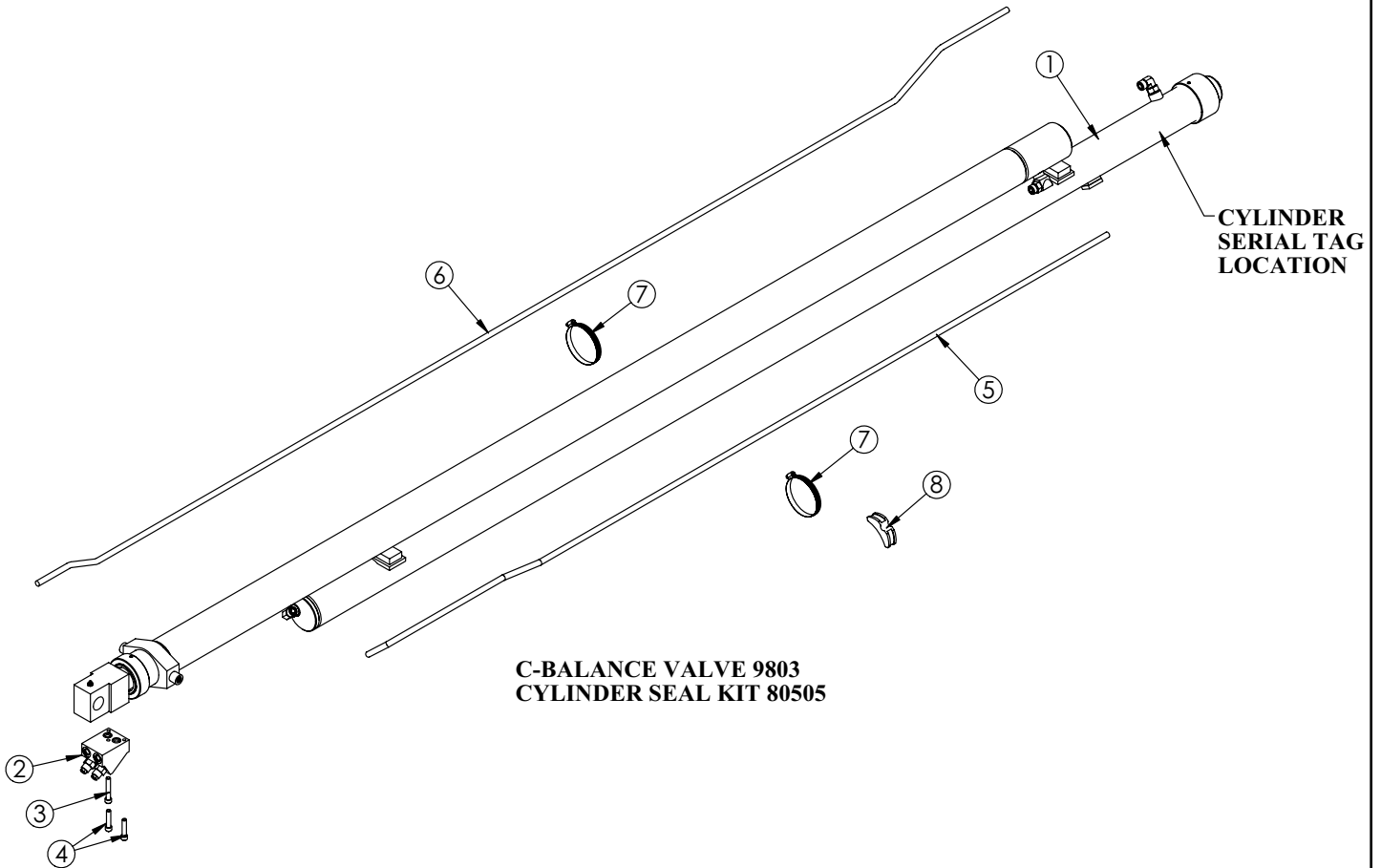
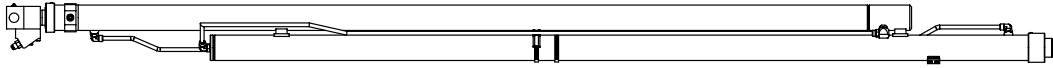

ITEM	PART	DESCRIPTION	QTY.
1	72939	CYLINDER EXT 2 STAGE 3.0X3.0X200 14530	1
2	28840	MANIFOLD ASM14528 EXT CBBB-LJN-XVO	1
3	14601	CAP SCR 0.38-16X2.25 SH ZC	1
4	11882	CAP SCR 0.38-16X1.75 SH ZC	2
5	73490	TUBE ASM 0.50X89.25 EXT CYL 14530	1
6	28843	TUBE ASM 0.50X 119.75 EXT CYL 14528 YZ	1
7	24729	HOSE CLAMP #52 3.00 - 3.75	2
8	18701	CLAMP PORT TUBE ZR518	1

Cable & Hook Assembly - PN 56274

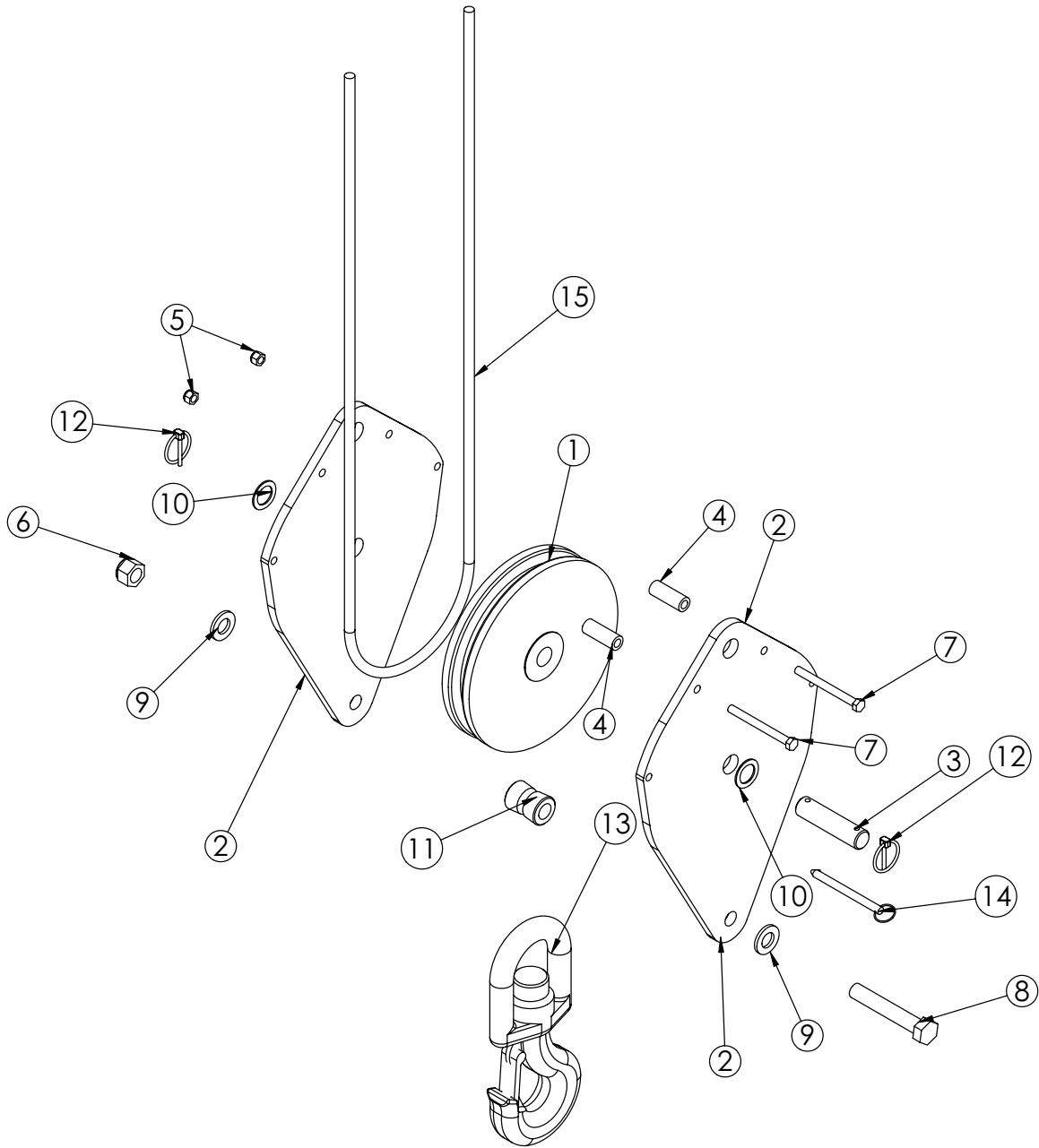

PN 56274

ITEM	PART	DESCRIPTION	QTY.
1	24557	SHEAVE 14528 10.00 DIA .50R/1.94 THK	1
2	56272PC	PLATE SNATCH BLOCK 14528	2
3	39874	PIN 1.00X4.06 COTTER	1
4	44643PC	COLLAR 0.44X0.75X2.00	2
5	0347	NUT 0.38-16 HHGR5 NYLOC	2
6	C0538	NUT 0.75-10 HHGR8 NYLOC	1
7	C0953	CAP SCR 0.38-16X4.00 HHGR5	2
8	5841	CAP SCR 0.75-10X4.50 HHGR8	1
9	C6219	WASHER 0.75 SAE FLAT YELLOW GR8	2
10	0867	MACHY WASHER 1.00ID 14GA	2
11	39844	BUSHING V HOOK	1
12	5753	PIN 0.19X1.56 LYNCH	2
13	26762	HOOK 7 TON SWIVEL CROSBY 1028632	1
14	13436	PIN .38X4.00 QUICK RELEASE	1
15	26761	WIRE ROPE .50 6X19 IWRC-XIP 120FT	1



Subject to Change without Notification.
© 2016 Stellar Industries, Inc.