



# 8406 H OWNERS MANUAL

Manual No. 480899

Rev. 9/2/2003

Serial No. \_\_\_\_\_

Mailing Address:  
P.O. Box 580697  
Tulsa, OK 74158-0697  
Physical Address:  
4707 N. Mingo Rd.  
Tulsa, OK 74117-5904

Phone (918) 836-0463  
Fax (918) 834-5979  
<http://www.autocrane.com>



# Auto Crane Warranty Registration

Fax Transmission

To: Warranty Department Fax: (918) 834-5979  
 From: \_\_\_\_\_ Date: \_\_\_\_\_  
 Re: Product Registration Pages: \_\_\_\_\_

**End User Information:** (Required for Warranty Activation)

Name: \_\_\_\_\_ Phone: \_\_\_\_\_  
 Address: \_\_\_\_\_  
 City: \_\_\_\_\_ State: \_\_\_\_\_ Zip: \_\_\_\_\_  
 Contact: \_\_\_\_\_ E-mail Address: \_\_\_\_\_

**Distributor Information:** (Required for Warranty Activation)

Name: \_\_\_\_\_  
 Address: \_\_\_\_\_  
 City: \_\_\_\_\_ State: \_\_\_\_\_ Zip: \_\_\_\_\_  
 Contact: \_\_\_\_\_ E-mail Address: \_\_\_\_\_

**Product Information:** (Required for Warranty Activation)

Model No.: \_\_\_\_\_ Serial No.: \_\_\_\_\_  
 Date Product Delivered: \_\_\_\_\_ Date Processed:\* \_\_\_\_\_  
 VIN # \_\_\_\_\_ \* For Auto Crane use only

## ONE REGISTRATION FORM PER UNIT (CRANE OR BODY)

Registration form must be mailed or faxed within 15 days of customer installation.

Mail to:  
 Warranty Department  
 Auto Crane Company  
 P.O. Box 581510  
 Tulsa, OK 74158-0697

**8406H SERIES**  
**OWNER'S MANUAL – REVISION RECORD**

<b>Revision Date</b>	<b>Section(s) Or Page(s)</b>	<b>Description of Change</b>
09/02/03	Last page	New 2-year warranty policy to replace 1-year warranty policy

# WARNINGS

**WARNING!** Federal law (49 cfr part 571) requires that the Final Stage Manufacturer of a vehicle certify that the vehicle complies with all applicable federal regulations. Any modifications performed on the vehicle prior to the final state are also considered intermediate stage manufacturing and must be certified as to compliance. The installer of this crane and body is considered one of the manufacturers of the vehicle. As such a manufacturer, the installer is responsible for compliance with all applicable federal and state regulations, and is required to certify that the vehicle is in compliance.

**WARNING!** It is the further responsibility of the installer to comply with the OSHA Truck Crane Stability Requirements as specified by 29 CFR part 1910.180 (C) (1).

**WARNING! NEVER OPERATE THE CRANE NEAR ELECTRICAL POWER LINES!**

**Death** or serious injury will result from boom, line, or load contacting electric lines. Do not use crane within 10 feet (3.05m) of electric power lines carrying up to 50,000 volts. One foot additional clearance is required for every additional 30,000 volts or less. **SEE DANGER DECAL (P/N 040529)** in this Owner's Manual.

**WARNING! NEVER.....**

- ◆ **EXCEED** load chart capacities (centerline of rotation to hoist hook).
- ◆ Un-reel last 5 wraps of cable from drum!
- ◆ Wrap cable around load!
- ◆ Attempt to lift or drag a load from the side! The boom can fail far below its rated capacity.
- ◆ Weld, modify, or use unauthorized components on any Auto Crane unit! This will void any warranty or liability. Also failure of the crane may result.
- ◆ Place a chain link on the tip of the hook and try to lift a load!
- ◆ Use a sling bar or anything larger than the hook throat that could prevent the hook latch from closing, thus negating the safety feature!
- ◆ Hold on any pendant Select Switch that will cause unsafe operating conditions!

**WARNING!** In using a hook with latch, **ALWAYS** make sure that the hook throat is closed before lifting a load! Proper attention and common sense applied to the use of the hoist hook and various slings will prevent possible damage to material being hoisted and may prevent injury to personnel.

**WARNING!** Failure to correctly plumb and wire crane can cause inadvertent operation and damage to crane and/or personnel!

**WARNING!** Auto Crane Company remote controlled cranes are not designed or intended to be used for any applications involving the lifting or moving of personnel.

**WARNING! ALWAYS** operate the crane in compliance with the load capacity chart. **DO NOT USE** the overload shutdown device to determine maximum rated loads, if the crane is equipped with this type of device.

## READ THIS PAGE

# ***TABLE OF CONTENTS***

## ***8406H SERIES***

INTRODUCTION	1-1
OPERATING PRACTICES & WARNINGS	2-2
OPERATION OF UNIT / OUTRIGGERS	2-3
CONTROLLER OPERATION	2-4
QUALIFICATIONS FOR OPERATORS	2-6
INSPECTION, TESTING, & MAINTENANCE	2-9
DECAL SECTION	2-14
GENERAL DIMENSIONS	3-1
MOUNTING AND INSTALLATION	3-2
LUBRICATION AND MAINTENANCE SCHEDULE	4-1
PEDESTAL ASSEMBLY	5-1
BOOM ASSEMBLY	5-3
ROTATION GEAR BOX	5-5
HOIST ASSEMBLY	5-7
GENERAL ASSEMBLY	5-11
ELECTRICAL SCHEMATIC	6-1
WIRE HARNESS ASSEMBLY	6-2
HYDRAULIC SECTION	7-1
DIAGNOSTICS	8-1
LOAD CHART	9-1
HARD WIRED SERIES, SUPPLEMENTAL INFORMATION	10-1
WARRANTY	LAST PAGE

# ***INTRODUCTION***

## ***8406H SERIES***

Auto Crane products are designed to provide many years of safe, trouble-free, dependable service when properly used and maintained.

To assist you in obtaining the best service from your crane and to avoid untimely crane and/or vehicle failure, this manual provides the following operating and service instructions. It is **specifically recommended** that all operating and service personnel consider this manual as mandatory material for reading and study before operating or servicing Auto Crane products. It is **highly recommended** that crane owners, equipment managers and supervisors also read this manual.

Auto Crane has incorporated several safety features in the 8406H crane for your protection.

For your convenience the overall dimensions of the 8406H crane are included on the General Dimension Drawing. Rotation and turning radius are also listed on that drawing.

Remember, the crane adds weight to the vehicle. Adding weight may change the driving and riding characteristics of the vehicle unless the appropriate overload spring(s) are installed on the truck. The payload of the vehicle is reduced by the weight of the crane. The operator should exercise care when loading the vehicle. Distributing the payload on the vehicle evenly will greatly improve the driving and riding characteristics of the vehicle.

---

**Auto Crane Company issues a limited warranty certificate with each unit sold. See last page for warranty policy.**

---

The 8406H cranes are attached directly to your 12 volt truck electrical system. The power cable is included with the crane. The 8406H is another highly efficient Auto Crane product. The use of a maintenance-free battery is not recommended for use on any Auto Crane product. The recommended alternator and battery that will give the longest life with the most useful duty cycle is a 75 amp alternator with a 500 cold cranking amp battery. These specifications should be considered minimum.

It has always been Auto Crane Company policy to handle all warranty claims we receive as promptly as possible. If a warranty claim involves discrepant material or workmanship, Auto Crane will take immediate corrective action. It is understandable that

Auto Crane Company cannot assume responsibility of liability when it is obvious that our products have been abused, misused, overloaded or otherwise damaged by inexperienced persons trying to operate the equipment without reading the manual.

***Auto Crane will not assume responsibility or liability for any modifications or changes made to unit, or installation of component parts done without authorization.***

Auto Crane maintains a strong distributor network and a knowledgeable Customer Service Department. In most cases, an equipment problem is solved via phone conversation with our customer service department. The customer service department also has the ability to bring a local distributor, a regional sales manager, or a factory serviceman into the solution of an equipment problem. If, through no fault of Auto Crane Company, it is necessary to send an experienced factory serviceman on a field service call, the rates stated in the Auto Crane Distributor's Flat Rate Manual will apply.

Auto Crane Company's extensive Research and Development Program allow our customers to use the best equipment on the market. Our Engineering Staff and our knowledgeable sales people, are always available to our customers in solving crane and winch-type application problems. When in doubt, call the Auto Crane factory.

### **DISTRIBUTOR ASSISTANCE:**

Should you require any assistance not given in this manual, we recommend that you consult your nearest Auto Crane Distributor. Our distributors sell authorized parts and have service departments that can solve almost any needed repair.

---

***NOTE: THIS MANUAL SHOULD REMAIN WITH THE CRANE AT ALL TIMES.***

---

This manual does not cover all maintenance, operating, or repair instructions pertinent to all possible situations. If you require additional information, please contact the **Auto Crane** Company at the following telephone number: **(918) 836-0463**. The information contained in the manual is in effect at the time of this printing. Auto Crane Company reserves the right to update this material without notice or obligation.

# ***--- IMPORTANT ---***

## ***SAFETY TIPS AND PRECAUTIONS***

1. No unqualified or unauthorized person shall be allowed to operate the crane.
2. **WARNING:** Never weld, modify, or use unauthorized components / parts on any Auto Crane unit. This will void any warranty or liability. Also, failure of the crane may result.
3. Make certain the vehicle meets minimum chassis requirements. (These requirements do not guarantee unit stability.)
4. Make certain the crane is installed per factory specifications. Contact your local distributor or the Auto Crane factory if any questions arise.
5. Visual inspections and tests should be conducted at the beginning of each shift each day to ensure that the crane and all its operating systems are in good condition and working order before it is used.
6. Inspect hydraulic hoses frequently for signs of deterioration, and replace them as required.
7. If a hydraulic break occurs, leave the area of the break and do not attempt to stop the break by hand as the hydraulic oil may be hot and under high pressure which can cause serious injury. Shut the system down as soon as possible.
8. Check the hook at least every thirty days for distortions or cracks and replace it as required.
9. Oil gears as required.
10. Stop all operations when cleaning, adjusting or lubricating the machine.
11. Keep dirt and grit out of moving parts by keeping a crane clean. Make sure machine is free of excess oil, grease, mud and rubbish, thus reducing accidents and fire hazards.
12. When a new cable is installed, operate first with a light load to let the cable adjust itself.
13. Locate the vehicle at the work site for the best stability possible.
14. Keep the vehicle in a level position while loading or unloading.
15. Observe operating area for obstructions and/or power lines that might be a hazard.
16. **WARNING:** NEVER OPERATE THE CRANE NEAR ELECTRICAL POWER LINES. Auto Crane Company recommends that the crane never be any closer to a power line (including telephone lines) than 10 feet at any point.
17. Allow the vehicle engine to warm up before operating crane.
18. Know the weight of your rigging and load to avoid overloading the crane.
19. Deduct the weight of the load handling equipment from the load rating to determine how much weight can be lifted.
20. All load ratings are based on crane capacity, NOT the vehicle stability.  
Remember in lifting a heavy load, the weight can create enough tipping moment to overturn the vehicle.
21. Always comply with load chart capacities, (centerline of rotation to hook).
22. Secure all loads before lifting.
23. Always set the emergency brake before beginning operation.
24. Keep objects and personnel clear of crane path during operation.
25. Operate control levers slowly and smoothly in order to meter oil flow for safe operation.
26. Always use outriggers from vehicle to the ground during crane operation. Ensure that they are firmly positioned on solid footings. Stand clear of outriggers while they are being extended.
27. If any outrigger, when extended, rests on a curb or other object that prevents it from extending to its maximum distance, shorten bearing or fulcrum point and reduce the maximum load accordingly.
28. When an outrigger will not reach the ground due to holes or grades, it shall be blocked up to provide level and firm support for the truck.
29. When working in soft earth, use wide pads under outrigger feet to prevent sinking.
30. Always store outriggers before transportation.

## **WARNING!**

Auto Crane Company cranes are not designed or intended for use in lifting or moving persons. Any such use shall be considered to be improper and the seller shall not be responsible for any claims arising there from. This sale is made with the express understanding that there is no warranty that the goods shall be fit for the purpose of lifting or moving persons or other improper use and there is no implied warranty or responsibility for such

# **--- IMPORTANT ---**

## ***SAFETY TIPS AND PRECAUTIONS***

31. Always store the crane in its stowed position for transportation.
32. Remember the overall height of the entire unit for garage door clearance or when moving under objects with low overhead clearance.
33. Disengage power takeoff (PTO) before moving the vehicle.
34. Always walk around the vehicle before moving.
35. Never drive with a load suspended from crane.
36. Do not take your eyes off a moving load. Look in the direction you are moving.
37. Never swing a load over people.
38. Do not stop the load sharply in midair so that it swings like a pendulum. Meter the control levers to avoid this situation.
39. Crane boom length should be kept as short as possible for maximum lifting capacity and greater safety. Longer booms require additional care in accelerating and decelerating the swing motion, and thus slow down the working cycle and reduce productivity.
40. Keep the load directly and vertically under the boom point at all times. Crane booms are designed primarily to handle vertical loads, not side lifts.  
**WARNING:** Never attempt to lift, drag, tow or pull a load from the side. The boom can fail far below its rated capacity.
41. Do not push down on anything with boom extensions, lift or outer boom function.
42. Do not lift personnel with any wire rope attachment or hook. There is no implied warranty or responsibility for such purposes.
43. **WARNING:** In using a safety hook, ALWAYS close the hook throat before lifting a load. Proper attention and common sense applied to the use of the hook and various slings will prevent possible damage to material being hoisted and may prevent injury to personnel.
44. **WARNING:** Never place a chain link on the tip of the hook and try to lift a load with the hoist.
45. **WARNING:** Never use a sling bar or anything larger than the hook throat which could prevent the safety latch from closing, thus negating the safety feature.
46. If the crane is equipped with an optional winch:
  - do NOT allow personnel to ride on loadline, hook, load, or any other device attached to winch line.
  - do NOT extend boom without reeling off line at the same time when using winch.
  - do pull load-block up against the boom tip.
47. Do not wrap the wire rope around sharp objects when using winch.
48. **WARNING:** Never unreel last 5 wraps of cable from drum.



# **--- IMPORTANT ---**

## **OPERATING PRACTICES & WARNINGS**

1. Make certain the vehicle meets minimum chassis requirements. (These requirements do not guarantee unit stability)
2. Make certain the crane is installed per factory specifications. Contact your local Distributor or the Auto Crane factory if any questions arise.
3. Keep the vehicle in as level a position as possible while loading or unloading.
4. **ALWAYS** set the vehicle emergency brake before beginning crane operations.
5. **ALWAYS** use outriggers from vehicle to the ground during crane operation. Make sure they are firmly positioned on solid footings.
6. All load ratings are based on crane capacity, **NOT** truck/crane stability.
7. Keep objects and personnel clear of crane path during operation.
8. Keep hoist cable pulled tight at all times.
9. **REMEMBER**, in lifting a heavy load, the weight can create enough tipping momentum to overturn the vehicle.
10. **ALWAYS** keep load as close to ground as possible.
11. Hydraulic hoses need to be inspected frequently for signs of deterioration, and be replaced as required.
12. The hoist hook is an important item that an operator should consider and use properly. It should be checked on a daily basis for distortion or cracks.
13. **ALWAYS** store outriggers before road travel.
14. **WARNING! NEVER OPERATE THE CRANE NEAR ELECTRICAL POWER LINES! Death** or serious injury will result from boom, line, or load contacting electric lines. Do not use crane within 10 feet (3.05m) of electric power lines carrying up to 50,000 volts. One foot additional clearance is required for every additional 30,000 volts or less.
15. **WARNING! NEVER EXCEED** load chart capacities (centerline of rotation to hoist hook).
16. **WARNING! NEVER** un-reel last 5 wraps of cable from drum!
17. **WARNING! NEVER** wrap cable around load!
18. **WARNING! NEVER** attempt to lift or drag a load from the side! The boom can fail far below its rated capacity.
19. **WARNING! NEVER** weld, modify, or use unauthorized components on any Auto Crane unit! This will void any warranty or liability. Also failure of the crane may result.
20. **WARNING! NEVER** place a chain link on the tip of the hook and try to lift a load!
21. **WARNING! NEVER** use a sling bar or anything larger than the hook throat that could prevent the hook latch from closing, thus negating the safety feature!
22. **WARNING!** In using a hook with latch, **ALWAYS** insure that the hook throat is closed before lifting a load! Proper attention and common sense applied to the use of the hoist hook and various slings will prevent possible damage to material being hoisted and may prevent injury to personnel. Switch on that will cause unsafe operating conditions!  
**WARNING! NEVER** hold any Control Select Switch on that will cause unsafe operating conditions!

## **WARNING!**

**Auto Crane Company remote controlled, stiff boom cranes are not designed or intended to be used for any applications involving the lifting or moving of personnel.**

## ***--- IMPORTANT --- OPERATION OF UNIT***

1. Make sure this manual has been thoroughly read by all crane operating personnel and supervisors.
2. A routine inspection of the crane should be mandatory before each operating day. Any defects should be corrected immediately.
3. At a job site the vehicle should be positioned so that the crane can adequately reach the load within the rated capacity (centerline of rotation to hoist hook).
4. Keep the vehicle as level as possible during operation.
5. For electric cranes, **engage emergency brake** and leave ignition on with transmission in neutral (or in park for automatic transmissions). Activate any crane power switches. For Auto Crane units requiring battery and hydraulic operation, **engage emergency brake**, place gear selector in neutral, press clutch, activate PTO, release clutch and after hydraulic fluid is warm, set throttle control to proper engine speed.
6. Always use outriggers from the truck to the ground. Be sure these are firm and adequately positioned. When rotating, **keep load as low to the ground as possible**.
7. Remove the transmitter from cab or storage area. Power transmitter on. Detach hook from dead man. Crane is now ready for operation.
8. Always boom up before rotating so the boom will clear the required boom support.
9. When extending the boom, always maintain clearance between the boom crown and the traveling block or hoist hook.
10. Always observe safe and practical operation to avoid possible accidents. Refer to Safety Tips and Precautions.
11. After completing lifting operations, return the boom to stowed position on the boom support. Avoid unneeded pressure on the boom support.
12. Store transmitter in proper location (in cab or storage area).
13. Return outriggers to stowed position. Make sure they are pinned in place or jacklegs are returned to compartment.
14. Check work area for any tools or equipment not stored.
15. Release throttle control, depress clutch and disengage PTO. Deactivate any crane power switches.
16. Report any unusual occurrence during crane operation that may indicate required maintenance or repair.
17. **NEVER** use two cranes to support a load too large for either crane.

## ***OPERATION OF OUTRIGGERS***

For hydraulic outriggers:

1. Shift crane/outrigger control valve to "outrigger" position.
2. Operate the outrigger control valves (located on the outrigger cylinders) to position the outriggers.
3. After outriggers are positioned, return crane/outrigger selector to "crane" position.
4. Crane is now ready to operate.

For manual outriggers:

1. Pull lock pins to release jack leg or drop down outrigger and move to outermost lock position.
2. Make sure lock pins are reinstalled properly.
3. Lower outrigger pad to firm ground and adjust foot to take out slack.
4. Crane is now ready to operate.

# CONTROLLER OPERATIONS

**Transmitter Layout:** The red light to the left of the Power On/Off button indicates low transmitter battery. (see “Charging the Transmitter”)

The green light to the right of the Power On/Off button indicates that the unit is transmitting. This light will come on when a function is activated.

In addition to the two lights mentioned above there are four function toggle switches. These functions from left to right are used to raise and lower the boom, raise and lower the hoist cable, rotate the crane and extend and retract the boom. There are also buttons for auxiliary functions such as Engine Start/Stop and Engine Fast Idle.

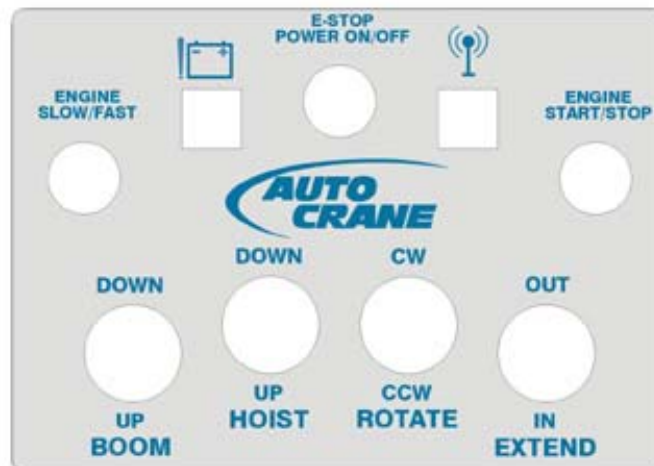

**Power On/Off (E-Stop) Button:** To turn the transmitter on, press and hold the Power On/Off button, release once the transmit light becomes solid. To turn the unit off, press and hold the power button, release once the transmit light stops flashing. When this button is pressed both the red battery low and the green transmit light will flash alternately and stop flashing once the unit is either on or off.

When turning the unit off, it will first send the emergency stop signal to the crane, then power down. When the transmitter is powered back up, the system will be in emergency stop mode and EC18 will be displayed when a function is activated. To exit E-Stop mode, press the red button once momentarily.

**IMPORTANT – THE POWER ON/OFF BUTTON ALSO OPERATES AS AN E-STOP. PRESS THE BUTTON MOMENTARILY TO DISABLE CRANE FUNCTIONS. THE E-STOP WILL NOT STOP THE TRUCK ENGINE.**

**Function Switches:** To operate a function, toggle one of the function switches with either the thumb of the hand holding the unit or the thumb or fingers of the opposite hand. Using the forefinger of the hand holding the unit, slowly pull the trigger back to start the function. The speed of the function increases as the trigger is pulled. More than one function can be activated at one time.

**NOTE: A FUNCTION SWITCH MUST BE ACTIVATED BEFORE THE TRIGGER IS PULLED OR THE CRANE WILL NOT OPERATE.**

# ***CONTROLLER OPERATION***

## **Auxiliary Buttons:**

Press the Engine Fast/Slow button to provide a maintained voltage to a throttle control if one is installed.

Press the Engine Start/Stop button to start and stop the engine if wired to do so.

## **Safety Features:**

For safety reasons the speed of all functions, excluding the hoist, is reduced when the lift cylinder pressure exceeds a set pressure. This will occur under load or under boom down operation. To limit slow operation of an unloaded crane, activate boom up momentarily after booming down to relieve cylinder pressure created by the counterbalance valve.

The crane is also equipped with an anti-bridging feature. The logic in the receiver will not allow the operator to rest the boom of the crane on a load supporting structure and lift a load. Doing so is dangerous and could damage the crane. When the crane is bridged, the receiver will display 'RSBM' which requires the boom to be raised. This feature is disabled when the crane is in the 'HOME' position to allow for stowing.

## **Operation Failure:**

If the crane does not operate as expected, observe the readout through the window on the receiver and refer to the front panel for explanation. The codes are further explained in the Diagnostics section of this manual. Please note that 'NRML' is displayed when the crane is operating normally and 'HOME' is displayed when the crane is forward and in a position to be stowed. "NRML" and "Home" will only be displayed when a function is activated, "EC01" is displayed when no function is activated.

## **Charging the Transmitter:**

The transmitter can be charged using one of three methods. It can be charged with the cigarette lighter charger, the pendant cable or the optional AC adapter (P/N 366505000). To charge the transmitter with the pendant cable, the crane must have electrical power. The crane can be operated by pendant or by FM remote therefore the battery can be charged without suspending operation of the crane.

The transmitter should be fully charged after approximately 6 to 8 hours of charging. Charging the transmitter for extended periods (3 or 4 days) is not recommended. Doing so will eventually degrade the battery and it will not keep a good charge.

# ***QUALIFICATIONS FOR AND CONDUCT OF OPERATORS AND OPERATING PRACTICES***

## **OPERATORS**

- 1 Crane operation shall be limited to personnel with the following minimum qualifications:**
  - A. designated persons
  - B. trainees under the direct supervision of a designated person
  - C. maintenance and test personnel (when it is necessary in the performance of their duties)
  - D. inspectors (crane).
- 2 No one other than the personnel specified above shall enter the operating area of a crane with the exception of persons such as oilers, supervisors, and those specified persons authorized by supervisors whose duties require them to do so and then only in the performance of their duties and with the knowledge of the operator or other persons.**

## **QUALIFICATIONS FOR OPERATORS**

- 3 Operators shall be required by the employer to pass a practical operating examination. Qualifications shall be limited to the specific type of equipment for which examined.**
- 4 Operators and operator trainees shall meet the following physical qualifications:**
  - A. Vision of at least 20/30 Snellen in one eye and 20/50 in the other, with or without corrective lenses.
  - B. Ability to distinguish colors, regardless of position, if colors differentiation is required for operation.
  - C. Adequate hearing with or without hearing aid for the specific operation.
- 5 Evidence of physical defects or emotional instability which render a hazard to operator or others, which in the opinion of the examiner could interfere with the operator's performance may be sufficient cause for disqualification. In such cases, specialized clinical or medical judgment and tests may be required.**
- 6 Evidence that the operator is subject to seizures or loss of physical control shall be sufficient reason for disqualification. Specialized medical tests may be required to determine these conditions.**
- 7 Operators and operator trainees should have normal depth perception, coordination, and no tendencies to dizziness or similar undesirable characteristics.**

- 8 In addition to the above listed requirements, the operator shall:**

- A. Demonstrate the ability to comprehend and interpret all labels, operator's manuals, safety codes and other information pertinent to correct crane operations.
- B. Possess knowledge of emergency procedures and implementation of same.
- C. Demonstrate to the employer the ability to operate the specific type of equipment.
- D. Be familiar with the applicable safety regulations.
- E. Understand responsibility for maintenance requirements of crane.
- F. Be thoroughly familiar with the crane and its control functions.
- G. Understand the operating procedures as outlined by the manufacturer.

## **CONDUCT OF OPERATORS**

- 9 The operator shall not engage in any practice which will divert his attention while actually operating the crane.**
- 10 Each operator shall be responsible for those operations under the operator's direct control. Whenever there is any doubt as to safety, the operator shall consult with the supervisor before handling the loads.**
- 11 The operator should not leave a suspended load unattended unless specific precautions have been instituted and are in place.**
- 12 If there is a warning sign on the switch or engine starting controls, the operator shall not close the switch or start the engine until the warning sign has been removed by the appointed person.**
- 13 Before closing the switch or starting the engine, the operator shall see that all controls are in the "OFF" or neutral position and all personnel are in the clear.**
- 14 If power fails during operation, the operator shall:**
  - A. move power controls to the "OFF" or neutral position.
  - B. land the suspended load and boom, if practical.
- 15 The operator shall be familiar with the equipment and its proper care. If adjustments or repairs are necessary, the operator shall report the same**

# ***QUALIFICATIONS FOR AND CONDUCT OF OPERATORS AND OPERATING PRACTICES***

promptly to the appointed person, and shall also notify the next operator.

**16 All controls shall be tested by the operator at the start of each shift. If any controls do not operate properly, they shall be adjusted or repaired before operations are begun.**

**17 Stabilizers shall be visible to the operator while extending or setting unless operator is assisted by a signal person.**

## **OPERATING PRACTICES**

### **HANDLING THE LOAD**

#### **18 Size of load**

- A. No crane shall be loaded beyond the rated load except for test purposes.
- B. The load to be lifted is to be within the rated load of the crane and its existing configuration.
- C. When loads which are not accurately known are to be lifted, the person responsible for the job shall ascertain that the weight of the load does not exceed the crane rated load at the radius at which the load is to be lifted.

#### **19 Attaching the load**

- A. The load shall be attached to the hook by means of slings or other devices of sufficient capacity.
- B. Hoist rope shall not be wrapped around the load.

#### **20 Moving the load**

- A. The operator shall determine that:
- B. The crane is level and, where necessary, the vehicle/carrier is blocked properly.
- C. The load is well secured and balanced in the sling or lifting device before it is lifted more than a few inches.
- D. Means are provided to hold the vehicle stationary while operating the crane.
- E. Before starting to lift, the hook shall be brought over the load in such a manner as to minimize swinging.
- F. During lifting care shall be taken that:

**1. there is no sudden acceleration or deceleration of the moving load.**

**2. load, boom or other parts of the crane do not contact any obstruction.**

- G. Cranes shall not be used for dragging loads sideways.
- H. This standard recognizes that articulating boom cranes are designed and intended for handling materials. They do not meet personnel lift or elevator requirements. Therefore, no lifting, lowering, swinging or traveling shall be done while a person is on the hook or load. Hook attached suspended work platforms (baskets) shall not be used with cranes covered by this standard. Work platforms attached to the boom must be approved by crane manufacturer.
- I. The operator should avoid carrying loads over people.
- J. When the crane is so equipped, the stabilizers shall be fully extended and set. Blocking under stabilizers shall meet the requirements as follows:
  - 1. strong enough to prevent crushing.**
  - 2. of such thickness, width and length as to completely support the stabilizer pad.**
- K. Firm footing under all tires, or individual stabilizer pads should be level. Where such a footing is not otherwise supplied, it should be provided by timbers, cribbing, or other structural members to distribute the load so as to not exceed allowable bearing capacity or the underlying material.
- L. In transit, the boom shall be carried in stowed position.
- M. When rotating the crane, sudden starts and stops shall be avoided. rotational speed shall be such that the load does not swing out beyond the radius at which it can be controlled.
- N. The crane shall not be transported with a load on the hook unless recommended by the manufacturer.
- O. No person should be permitted to stand or pass under a suspended load.

**21 Stowing procedure. Follow the manufacturer's procedure and sequence when stowing and un-stowing the crane.**

# **QUALIFICATIONS FOR AND CONDUCT OF OPERATORS AND OPERATING PRACTICES**

## **MISCELLANEOUS**

### **OPERATING NEAR ELECTRICAL POWER LINES**

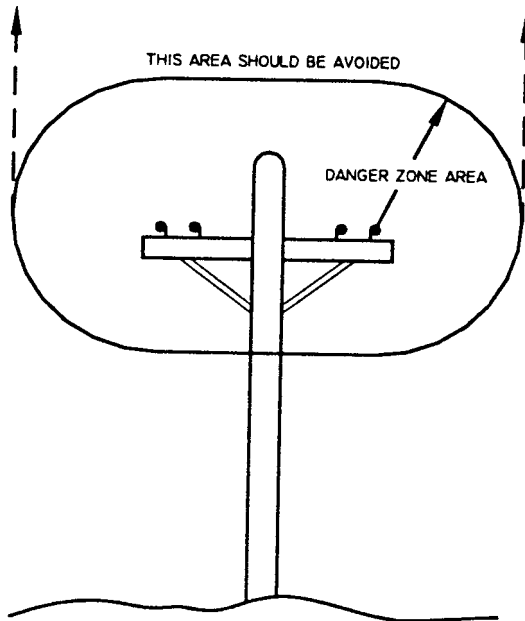

**22 Cranes shall be operated so that no part of the crane or load enters into the danger zone shown above.**

#### **EXCEPTIONS**

- A. The danger zone may be entered after confirmation by an appointed person that the electrical distribution and transmission lines have been de-energized and visibly grounded at the point of work; or
- B. The danger zone may be entered if insulating barriers (not a part of nor an attachment to the crane) have been erected to prevent physical contact with the lines.

**23 For lines rated 50 kV or below, minimum clearance between the lines and any part of the crane or load (including handling appendages) shall be 10 ft. (3m). For higher voltages, see Table 1.**

**24 Caution shall be exercised when working near overhead lines, because they can move horizontally or vertically due to wind, moving the danger zone to new positions.**

**25 In transit with no load and boom lowered the clearance shall be specified in Table 1.**

**26 A qualified signalperson shall be assigned to observe the clearance and give warning before approaching the above limits.**

- A. Any overhead wire shall be considered to be an energized line unless and until the person owning such line or the electrical utility authorities verify that it is not an energized line.
- B. Exceptions to this procedure, if approved by the administrative or regulatory authority if the alternate procedure provides equivalent protection and set forth in writing.
- C. Durable signs shall be installed at the operator's station and on the outside of the crane, warning that electrocution or serious bodily injury may occur unless a minimum clearance of 10 ft. (3.0m) between the crane or the load being handled and energized power lines. Greater clearances are required because of higher voltage as stated above. These signs shall be revised but not removed when local jurisdiction requires greater clearances.

**TABLE 1**

normal voltage, kV (phase to phase)		minimum required clearance	
		ft	(m)
<b><u>when operating near high voltage power lines</u></b>			
over	to 50	10	(3.05)
over	50 to 200	15	(4.6)
over	200 to 350	20	(6.1)
over	350 to 500	25	(7.62)
over	500 to 750	35	(10.67)
over	750 to 1000	45	(13.72)
<b><u>while in transit with no load and boom lowered</u></b>			
over	to 0.75	4	(1.22)
over	0.75 to 50	6	(1.83)
over	50 to 345	10	(3.83)
over	345 to 750	16	(4.87)
over	750 to 1000	20	(6.1)

# ***INSPECTION, TESTING AND MAINTENANCE***

## **GENERAL**

### **INSPECTION CLASSIFICATION**

- 1 Initial inspection. Prior to initial use, all new, altered, modified or extensively repaired cranes shall be inspected by a designated person to insure compliance with provisions of this standard.**
- 2 Regular inspection. Inspection procedure for cranes in regular service is divided into two general classifications based upon the intervals at which inspection should be performed. The intervals in turn are dependent upon the nature of the components of the crane and the degree of their exposure to wear, deterioration, or malfunction. The two general classifications are herein designated as "frequent" and "periodic" with respective intervals between inspections as defined below.**
  - A. frequent inspection - daily to monthly intervals
  - B. periodic inspection - one to twelve intervals, or as specifically recommended by the manufacturer

### **FREQUENT INSPECTION**

- 3 Inspection shall be performed by designated personnel.**
  - A. control mechanisms for maladjustment interfering with proper operation - daily, when used
  - B. control mechanisms for excessive wear of components and contamination by lubricants or other foreign matter
  - C. safety devices for malfunction
  - D. all hydraulic hoses, particularly those which flex in normal operation of crane functions, should be visually inspected once every working day, when used
  - E. hooks and latches for deformation, chemical damage, cracks, and wear. Refer to ANSI/ASME B30.10
  - F. rope reeving for compliance with crane manufacturer's specifications, if optional winch is used
  - G. electrical apparatus for malfunctioning, signs of excessive deterioration, dirt and moisture accumulation

- H. hydraulic system for proper oil level and leaks daily
- I. tires for recommended inflation pressure, cuts and loose wheel nuts
- J. connecting pins and locking device for wear and damage

### **PERIODIC INSPECTION**

- 4 Deformed, cracked or corroded members in the crane structure and carrier.**
- 5 Loose bolts, particularly mounting bolts.**
- 6 Cracked or worn sheaves and drums.**
- 7 Worn, cracked, or distorted parts such as pins, bearings, shafts, gears, rollers and devices.**
- 8 Excessive wear on brake and clutch system parts and lining.**
- 9 Crane hooks inspected for cracks.**
- 10 Travel steering, braking, and locking devices, for malfunction.**
- 11 Excessively worn or damaged tires.**
- 12 Hydraulic and pneumatic hose, fittings, and tubing inspection.**
  - A. evidence of leakage at the surface of the flexible hose or its junction with metal and coupling
  - B. blistering, or abnormal deformation to the outer covering of the hydraulic or pneumatic hose
  - C. leakage at threaded or clamped joints that cannot be eliminated by normal tightening or recommended procedures
  - D. evidence or excessive abrasion or scrubbing on the outer surface of a hose, rigid tube, or fitting. Means shall be taken to eliminate the interference of elements in contact or otherwise protect the components



# ***INSPECTION, TESTING AND MAINTENANCE***

## **GENERAL**

### **13 Hydraulic and pneumatic pumps and motors inspection.**

- A. loose bolts or fasteners
- B. leaks at joints between sections
- C. shaft seal leaks
- D. unusual noises or vibrations
- E. loss of operating speed
- F. excessive heating of the fluid
- G. loss of pressure

### **14 Hydraulic and pneumatic valves inspection.**

- A. cracks in valve housing
- B. improper return of spool to neutral position
- C. leaks at spools or joints
- D. sticking spools
- E. failure of relief valves to attain or maintain correct pressure setting
- F. relief valve pressure shall be checked as specified by the manufacturers

### **15 Hydraulic and pneumatic cylinders inspection.**

- A. drifting caused by fluid leaking across piston
- B. rod seals leaking
- C. leaks at welding joints
- D. scored, nicked, or dented cylinder rods
- E. damaged case (barrel)
- F. loose or deformed rod eyes or connecting joints

**16 Hydraulic filters.** Evidence of rubber particles on the filter elements may indicate hose, "O" ring, or other rubber component deterioration. Metal chips or pieces on the filter may denote failure in pumps, motors, or cylinders. Further checking will be necessary to determine origin of the problem before corrective action can be taken.

**17 Labels are to be in place and legible.**

### **CRANES NOT IN REGULAR USE**

**18 A crane which has been idle for a period of over one month or more, but not less than six months, shall be given an inspection conforming with the initial-regular- frequent inspections.**

**19 A crane which has been idle for a period of over six months shall be given a complete inspection conforming with the initial-regular-frequent inspection requirements.**

### **INSPECTION RECORDS**

**20 Dated records for periodic inspection should be made on critical items such as brakes, crane hooks, rope, hydraulic and pneumatic cylinders, and hydraulic and pneumatic relief pressure valves. Records should be kept available to an appointed person.**

### **OPERATIONAL TESTS**

**21 Prior to initial use, all new, altered, modified, or extensively repaired cranes shall be tested for compliance with the operational requirements of this section, including functions such as the following:**

- A. load lifting and lowering mechanisms
- B. boom lifting and lowering mechanisms
- C. boom extension and retraction mechanisms
- D. swing mechanisms
- E. safety devices
- F. operating controls comply with appropriate function labels

***Operational crane test results shall be made available to an appointed person.***

### **RATED TEST LOAD**

***Prior to initial use, altered, modified, or extensively repaired cranes shall be load tested by or under the direction of an appointed person.***

# ***INSPECTION, TESTING AND MAINTENANCE***

## **GENERAL**

22 Test loads shall not exceed 110% of the manufacturer's load ratings.

23 Written reports shall be maintained showing test procedures and confirming the adequacy of repairs.

### **MAINTENANCE**

#### **PREVENTIVE MAINTENANCE**

24 Before adjustment and repairs are started on a crane, the following precautions shall be taken as applicable:

- A. crane placed where it will cause the least interference with other equipment or operations
- B. all controls at the "off" position
- C. starting means rendered inoperative
- D. boom lowered to the ground if possible or otherwise secured against dropping
- E. relieve hydraulic oil pressure from all hydraulic circuits before loosening or removing hydraulic components

25 Warning or "OUT OF ORDER" signs shall be placed on the crane controls.

26 After adjustments and repairs have been made, the crane shall not be returned to service until all guards have been reinstalled, trapped air removed from hydraulic system (if required), safety devices reactivated, and maintenance equipment removed.

### **ADJUSTMENTS AND REPAIRS**

27 Any hazardous conditions disclosed by the inspection requirements shall be corrected before operation of crane is resumed, Adjustments and repairs shall be done only by designated personnel.

28 Adjustments shall be maintained to assure correct functioning of components, The following are examples:

- A. functional operating mechanism
- B. safety devices

C. control systems

29 Repairs or replacements shall be provided as needed for operation.

***The following are examples:***

- A. critical parts of functional operating mechanisms which are cracked, broken, corroded, bent, or excessively worn
- B. critical parts of the crane structure which are cracked, bent, broken, or excessively corroded
- C. crane hooks showing cracks, damage, or corrosion shall be taken out of service. Repairs by welding are not recommended

30 Instructions shall be provided by the manufacturer for the removal of air from hydraulic circuits.

### **LUBRICATION**

***All moving parts of the crane, for which lubrication is specified, should be regularly lubricated per the manufacturer's recommendations and procedures.***

### **ROPE INSPECTION**

31 Frequent Inspection

- A. All running ropes in service should be visually inspected once each working day. A visual inspection shall consist of observation of all rope which can be in use during the days operations. These visual observations should be considered with discovering gross damage such as listed below, which may be an immediate hazard.

1. **distortion of the rope such as kinking, crushing, un-stranding, birdcaging, main strand displacement, or core protrusion. Loss of rope diameter in a short length or unevenness of outer strands should be replaced**
2. **general corrosion**
3. **broken or cut strands;**
4. **number, distribution and type of visible broken wires. When such damage is**

# ***INSPECTION, TESTING AND MAINTENANCE***

## **GENERAL**

**discovered, the rope shall either be removed from service or given as inspection.**

- B. Care shall be taken when inspecting sections of rapid deterioration such as flange points, crossover points, and repetitive pickup points on drums.

### **32 Periodic inspection**

- A. The inspection frequency shall be determined by a qualified person and shall be based on such factors as:

- 1. expected rope life as determined by experience on the particular installation or similar installations**
- 2. severity of environment**
- 3. percentage of capacity lifts**
- 4. frequency rates of operation**
- 5. exposure to shock loads**

***Inspection need not be at equal calendar intervals and should be more frequent as the rope approaches the end of its service life. This inspection shall be made at least annually.***

- B. Periodic inspection shall be performed by a designated person. This inspection shall cover the entire length of the rope. Only the surface wires need be inspected. No attempt should be made to open the rope. Any deterioration results in appreciable loss of original strength, such as described below, shall be noted and determination made as to whether use of the rope would constitute a hazard: points listed above reduction of rope diameter below nominal diameter due to loss of core support, internal or external corrosion, or wear of outside wires; severely corroded, cracked, bent, worn or improperly applied connections;
- C. Care shall be taken when inspecting sections subject to rapid deterioration such as the following:

- 1. sections in contact with saddles, equalizer sheaves, or other sheaves where rope travel is limited**

- 2. sections of the rope at or near terminal ends where corroded or broken wires may protrude**

### **ROPE REPLACEMENT**

- 33 No precise rules can be given for determination of the exact time for replacement of rope, since many variable factors are involved.**

***Continued use in this respect depends upon good judgement by a designated person in evaluating remaining strength in a used rope after allowance for deterioration disclosed by inspection. Continued rope operation depends upon this remaining strength.***

- 34 Conditions such as the following shall be reason for questioning continued use of the rope or increasing the frequency of inspection:**

- A. in running ropes, six randomly distributed broken wires in one lay or three broken wires in one strand in one lay
- B. one outer wire broken at the contact point with the core of the rope structure and protrudes or loops out of the rope structure. Additional inspection of this section is required
- C. wear of one third of the original diameter of the outside individual wire
- D. kinking, crushing, birdcaging, or any other damage resulting in distortion of the rope structure
- E. evidence of any heat damage from any cause
- F. reduction from nominal diameter of more than 1/64 in. (0.4mm) for diameters up to and including 5/16 in. (8 mm), 1/32 in. (0.8 mm) for diameter 3/8 in. (9.5 mm) to and including 1/2 in. (13 mm), 3/64 in. (1.2 mm) for diameter 9/16 in. (14.5 mm) to and including 3/4 in. (19 mm), 1/16 in. (1.6 mm) for diameter 7/8 in. (22 mm) to and including 11/8 in. (29 mm), 3/32 in. (2.4 mm) for diameters 11/4 in. (32 mm) to and including 11/2 in. (38 mm)
- G. In standing ropes, more than two broken wires in one lay in sections beyond end connections or more than one broken wire at an end connection.

# ***INSPECTION, TESTING AND MAINTENANCE***

## **GENERAL**

H. Replacement rope shall have a strength rating at least as great as the original rope furnished or recommended by the crane manufacturer. Any deviation from the original size, grade, or construction shall be specified by a rope manufacturer, or a qualified person.

**35 Rope not in regular use: all rope which has been idle for a period of a month or more due to shutdown or storage of a crane on which it is installed, shall be given and inspection in accordance with above information before it is placed in service. This inspection shall be for all types of deterioration and shall be performed by a qualified person.**

### **36 Inspection records**

- A. frequent inspection- no records required
- B. periodic inspections- in order to establish data as a basis for judging the proper time for replacement, a dated report condition at each periodic inspection should be kept on file. This report shall cover points of deterioration listed above.

## **ROPE MAINTENANCE**

**37 Rope should be stored to prevent damage or deterioration.**

**38 Unreeling or uncoiling of rope shall be done as recommended by the rope manufacturer and with care to avoid kinking or inducing twist.**

**39 Before cutting a rope, seizing shall be placed on each side of the place where the rope is to be cut to prevent unlaying of the strands. On pre-formed rope, one seizing on each side of the cut is required. On non-preformed ropes of 7/8 in. (22 mm) diameter or smaller, two seizings on each side of the cut are required, and for non-preformed rope 1 in. (25 mm) diameter or larger, three seizings on each side of the cut are required.**

**40 During installation care should be exercised to avoid dragging of the rope in the dirt or around objects which will scrape, nick crush or induce sharp bends in it.**

**41 Rope should be maintained in a well-lubricated condition. It is important that lubricant applied as a part of a maintenance program shall be compatible with the original lubricant and to this end the rope manufacturer should be consulted. Lubricant applied shall be the type which does not hinder visual inspection. Those sections of rope which are located over sheaves or otherwise hidden during inspection and maintenance procedures require special attention when lubricating rope. The object of rope lubrication is to reduce internal friction and to prevent corrosion.**

**42 When an operating rope shows greater wear or well defined localized areas than on the remainder of the rope, rope life can be extended in cases where a section at the worn end, and thus shifting the wear to different areas of the rope.**

# SAFETY DECAL SECTION

## 8406H

Revised 1/02

PART NO.: 040579  
 DECAL: OPERATION INSTRUCTIONS  
 FUNCTION: To inform the operator of the proper procedure to follow for safe operation of the crane.  
 USED ON: All cranes  
 QUANTITY: 1  
 PLACEMENT: Right side plate  
 :

FG. SD-1

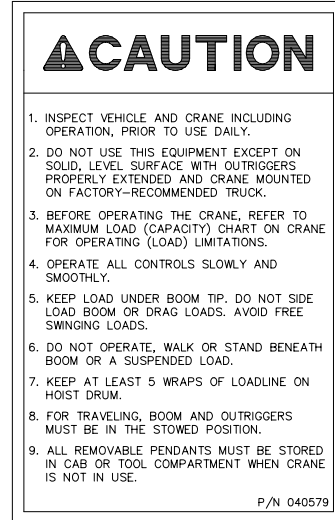

PART NO.: 040580  
 DECAL: OPERATOR TRAINING  
 FUNCTION: To inform the operator of the need to receive proper training before using the crane.  
 USED ON: All cranes  
 QUANTITY: 1  
 PLACEMENT: Right side plate

FIG. SD-2

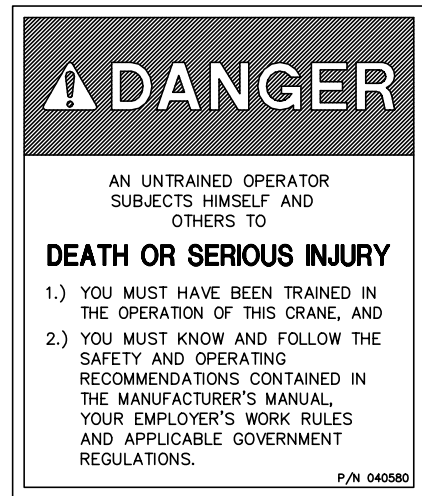

PART NO.: 040632  
 DECAL: TAMPERING WITH OVERLOAD DEVICE  
 FUNCTION: To inform the operator that tampering with the overload device may cause a unit failure or possible personnel injury.  
 USED ON: All cranes equipped with a load sensor.  
 QUANTITY: 1  
 PLACEMENT: Right side of valve cover

FIG. SD-3

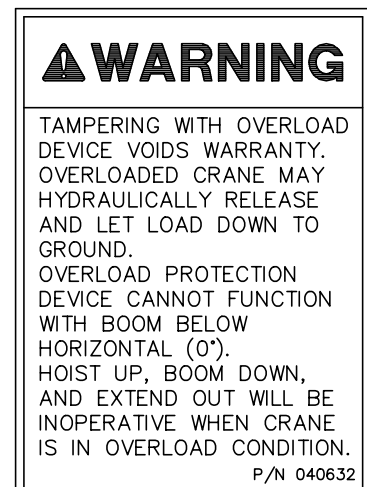

# SAFETY DECAL SECTION

## 8406H

Revised 1/02

PART NO.: 040529  
DECAL: ELECTROCUTION HAZARD  
FUNCTION: To inform the operator of the hazard involved with contacting electrical power lines with crane boom.  
USED ON: Articulated & Stiff Boom Cranes  
QUANTITY: 2  
PLACEMENT: Both sides of end of lower boom

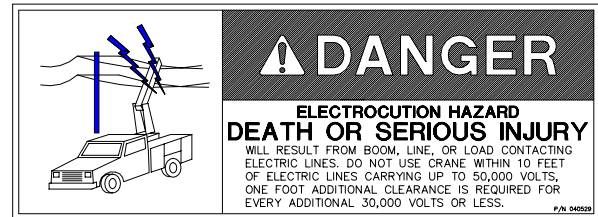

FIG. SD-4

PART NO.: 040517  
DECAL: STAY CLEAR OF BOOM  
FUNCTION: To inform the operator of the hazard of proximity or contact with the crane boom during operation.  
USED ON: All cranes  
QUANTITY: 2  
PLACEMENT: Both sides of crown

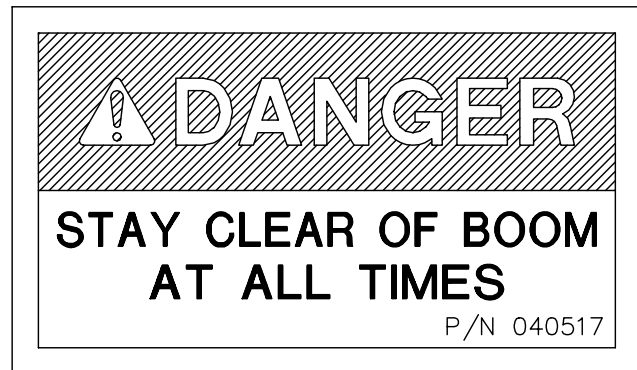

FIG. SD-5

# ***SAFETY DECAL SECTION***

## ***8406H***

Revised 1/02

PART NO.: 040587  
DECAL: LOAD SENSOR, DON'T TAMPER  
FUNCTION: To inform the operator that the load sensor is pre-set and that tampering with the sensor may cause potentially hazardous situation.  
USED ON: All cranes equipped with a load sensor.  
QUANTITY: 1  
PLACEMENT: On the lift cylinder near the load sensor

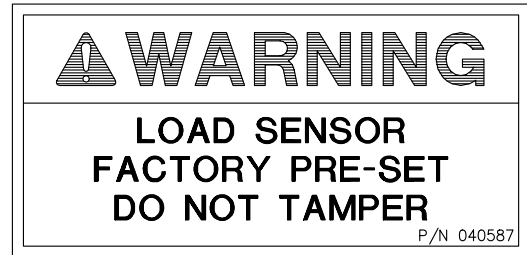

FIG. SD-7

PART NO.: 040519  
DECAL: SCISSORS POINT  
FUNCTION: To inform the operator of possible danger at scissors point on crane.  
USED ON: All cranes  
QUANTITY: 2  
PLACEMENT: Both sides of the lift cylinder

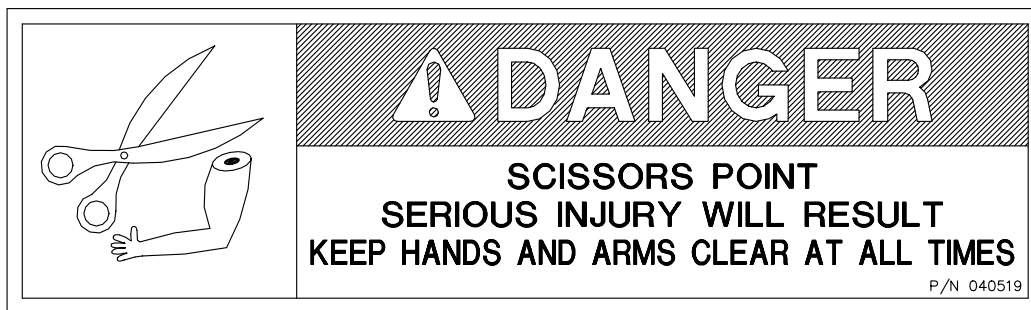
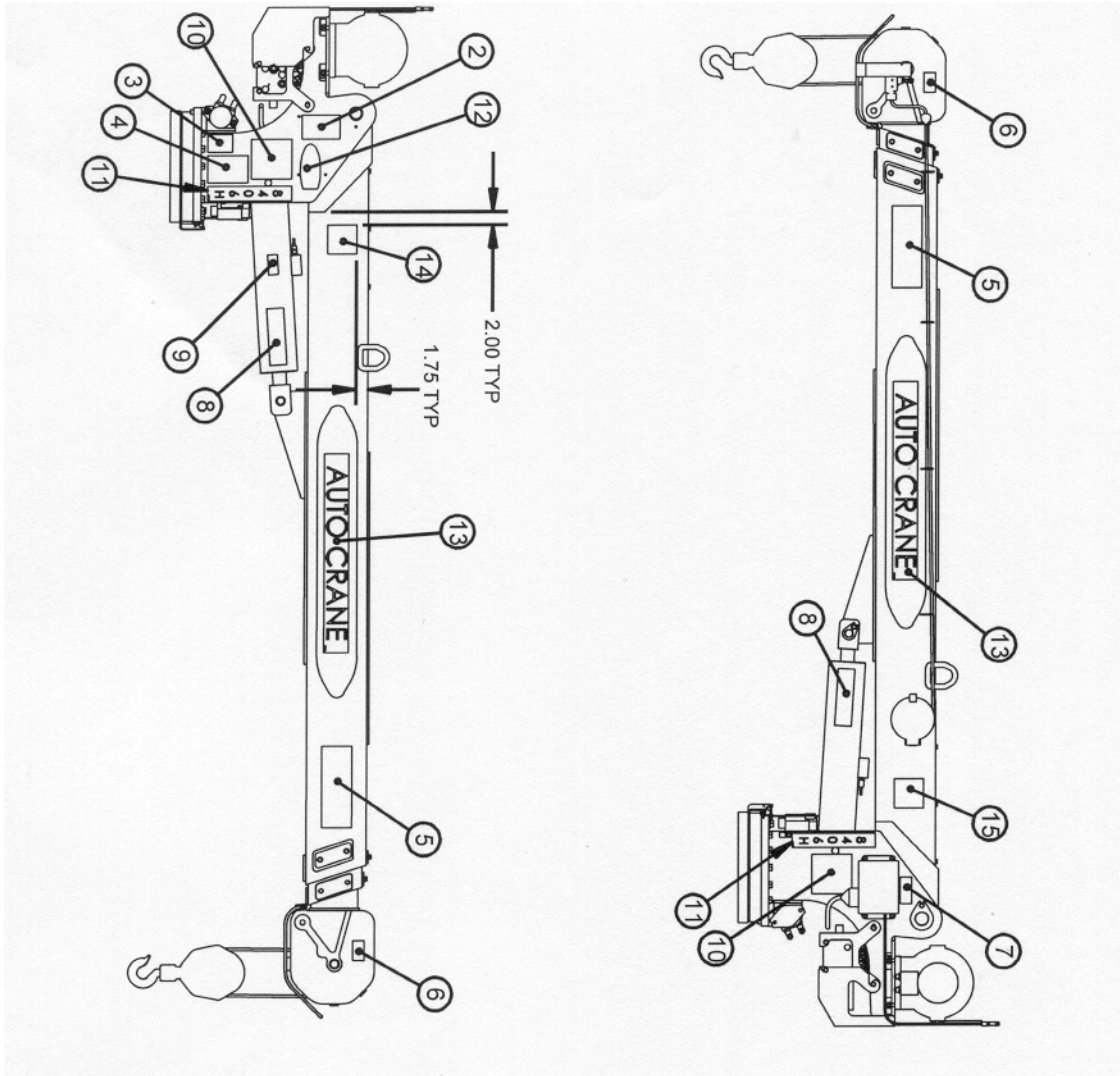

FIG. SD-8

# DECAL LAYOUT

## 8406H





# ***DECAL LAYOUT***

## ***8406H***

<b>ITEM NO.</b>	<b>QTY.</b>	<b>PART NO.</b>	<b>DESCRIPTION</b>
2	1	040579	DECAL OPERATION INSTRUCTIONS
3	1	040632	DECAL WARNING - OVERLOAD
4	1	040580	DECAL TRAINED OPERATOR
5	2	040529	DECAL POWER LINE HAZARD
6	2	040517	DECAL STAY CLEAR OF BOOM
7	1	330622	DECAL SERIAL NO
8	2	040519	DECAL DANGER SCISSOR POINT
9	1	040587	DECAL WARNING LOAD SENSOR
10	2	480852000	DECAL LOAD CHART 8406H
11	2	480851000	DECAL 8406H
12	2	360034	DECAL AUTO CRANE LOGO
13	2	366389	DECAL AUTO CRANE
14	1	320318	DECAL ANGLE IND RIGHT
15	1	320318001	DECAL ANGLE IND LEFT

# GENERAL DIMENSIONS

## 8406H

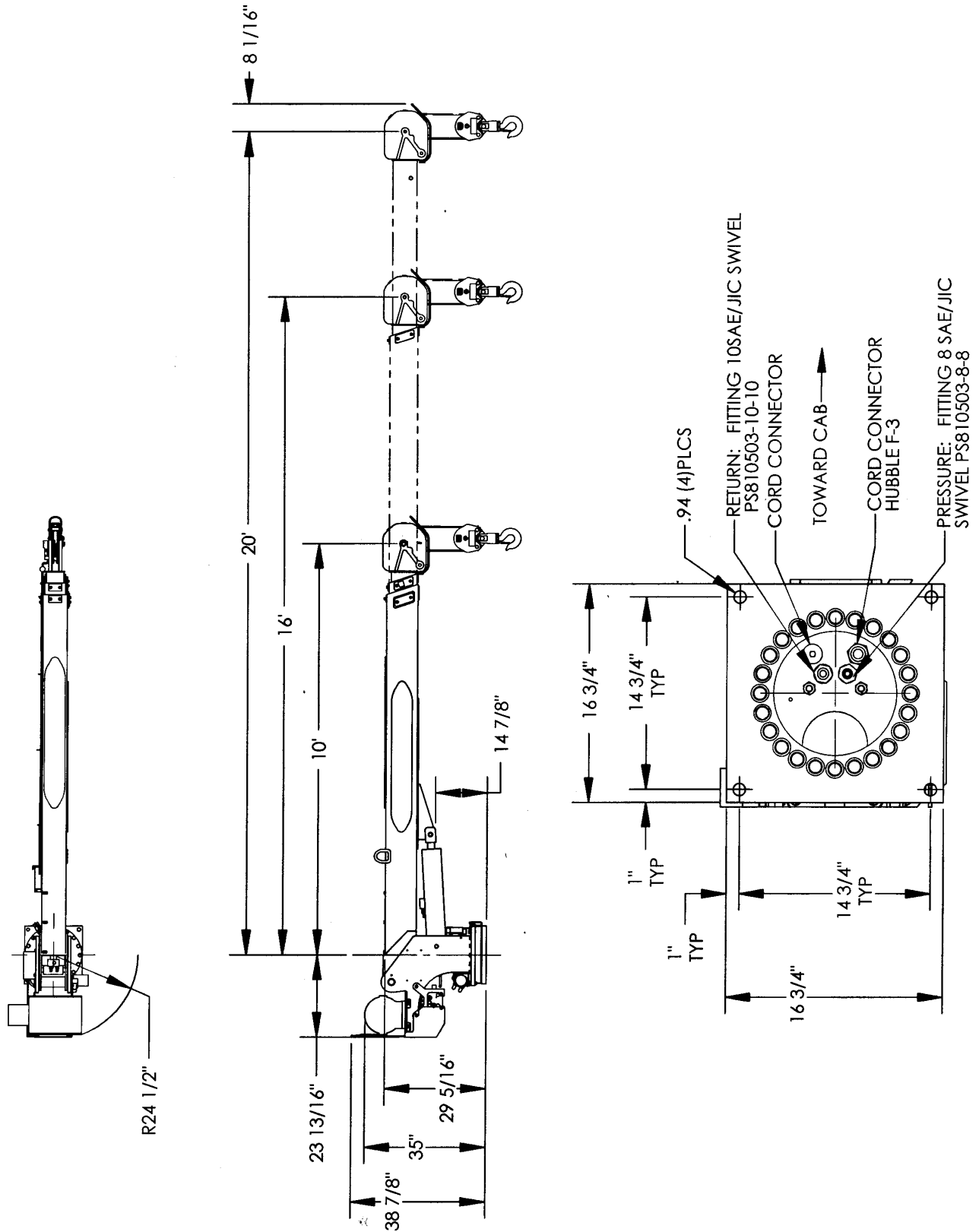



## MOUNTING AND INSTALLATION 8406H

1. Check to make sure the following items are with your crane:

ITEM	PART NO.	DESCRIPTION
1.	480854	Swivel Block
2.	480899	Owners Manual
3.	015104	Bolt 7/8 NF x 5", Grade 8, (4 Req'd)
4.	022200	Washer Split Lock 7/8 (4 Req'd)
5.	366500002	Transmitter
6.	366500004	Pendant Cable

2. Pressure and return hoses are not furnished with this crane. The hoses must be provided by the installer and the lengths determined at installation.

### REQUIREMENTS FOR INSTALLATION USING 8 GALLON RESERVOIR

A. RETURN LINE FROM CRANE TO RESERVOIR (IN COMPARTMENT): -10 SAE 100R2 (OR EQUIVALENT). HOSE LENGTH IS DETERMINED BY INSTALLER. RETURN LINES LONGER THAN 6 FEET SHOULD BE SIZE -12. HOSE END FITTINGS ARE -10 JIC FEMALE SWIVEL (CRANE END) AND -10 JIC FEMALE SWIVEL (RESERVOIR END).

B. PRESSURE LINE FROM PUMP TO CRANE: -8 SAE 100R2 (OR EQUIVALENT). HOSE LENGTH IS DETERMINED BY INSTALLER. HOSE END FITTINGS ARE BOTH -8 JIC FEMALE SWIVEL.

### NOTE:

REFER TO OWNERS MANUAL FOR ADDITIONAL INSTALLATION INFORMATION.

**CAUTION - FAILURE TO USE CLEAN HYDRAULIC HOSES AND COMPONENTS MAY  
CONTAMINATE THE CRANE AND HYDRAULIC SYSTEM AND VOID WARRANT**

- Crane must be provided with a flow of 13 gallons per minute and a pressure of 2,750 PSI. Excess flow will cause erratic operation, and too little flow will cause poor crane operation.
- Vehicle should meet minimum GVW rating of 20,500 pounds.
- The vehicle MUST be equipped with an engine speed control and tachometer.
- Make sure mounting surface is properly reinforced to withstand 50,000 ft-lb capacity loading of crane and that outriggers are used to provide total stability for the truck.
- A 13 1/2" dia. hole should be cut out of mounting location (centered with mounting bolts) for access to lower ring gear bolts and hydraulic connections.
- Make sure the mounting bolts are 7/8x dia, grade 8. Torque bolts to 440 ft-lbs (dry).
- When crane is not in operation, a boom support should always be used. Traveling block should be connected to hood loop.
- Electrical hookup:

Wiring (cable from base of crane):

- CONNECT THE BLACK WIRE TO THE BATTERY NEGATIVE (GROUND).
- CONNECT THE RED WIRE TO THE BATTERY POSITIVE.
- OPTIONALLY, USE THE WHITE WIRE FOR ENGINE FAST/SLOW.
- OPTIONALLY, USE THE BLUE WIRE FOR ENGINE START.
- OPTIONALLY, USE THE ORANGE WIRE FOR ENGINE STOP.

**WARNING! FAILURE TO CORRECTLY PLUMB AND WIRE CRANE CAN CAUSE  
INADVERTENT OPERATION AND DAMAGE TO CRANE AND/OR PERSONNEL!**

- Once crane and plumbing are installed on the truck, fill the reservoir to top of sight glass (mobil DTE 13 or equal). Before operating crane, connect together the pressure and return hoses going to base of crane using 10-8 JIC union and engage PTO with engine running. Allow oil to circulate for 15 to 20 minutes. This will flush contaminants from the system back to the return line filter. Operate all cylinders to full extension and retraction a minimum of six times, to bleed air from system. Return all cylinders to the stored position and disengage PTO. Refill reservoir to top sight glass. To ensure 13 gallons per minute (GPM), install an in-line flow meter between the crane and the reservoir in the return hose.
- Load test the crane to ensure proper functioning and truck stability.



## MOUNTING AND INSTALLATION CONT.

13. Make certain the owner's manual is delivered to the customer.
14. For additional help: call the service department at the Auto Crane Company. (918) 836-0463 (TULSA, OKLAHOMA)

### **WARNING**

**FEDERAL LAW** (49 CFR PART 571) REQUIRES THAT THE FINAL STAGE MANUFACTURER OF A VEHICLE CERTIFY THAT THE VEHICLE COMPLIES WITH ALL APPLICABLE FEDERAL REGULATIONS. ANY MODIFICATIONS PERFORMED ON THE VEHICLE PRIOR TO THE FINAL STAGE ARE ALSO CONSIDERED INTERMEDIATE STAGE MANUFACTURING AND MUST BE CERTIFIED AS TO COMPLIANCE. THE INSTALLER OF THIS CRANE AND BODY IS CONSIDERED ONE OF THE MANUFACTURERS OF THE VEHICLE. AS SUCH A MANUFACTURER, THE INSTALLER IS RESPONSIBLE FOR COMPLIANCE WITH ALL APPLICABLE FEDERAL AND STATE REGULATIONS, AND IS REQUIRED TO CERTIFY THAT THE VEHICLE IS IN COMPLIANCE.

**IT IS THE FURTHER RESPONSIBILITY** OF THE INSTALLER OF THE CRANE TO COMPLY WITH THE **OSHA** TRUCK CRANE STABILITY REQUIREMENTS AS SPECIFIED BY 29 CFR PART 1910.180 (C) (1).

## **LUBRICATION & MAINTENANCE SCHEDULE**

### **8406H CRANE**

SERVICE PERFORMED	DAY	WEEKLY	3 MOS	6 MOS	YEAR	NOTES
LOAD HOOK	X					INSPECT HOOK & LATCH FOR DEFORMATION, CRACKS, & CORROSION
CABLE DRUM	X					MAKE SURE CABLE IS WOUND EVENLY ON DRUM
HOIST / BOOM CABLE	X					CHECK FOR FLATTENING, KINKS, & BROKEN STRANDS, SEE MANUAL
HYD. HOSES	X					VISUAL INSPECTION
HYD. FLUID	X					CHECK FLUID LEVEL
MOUNTING BOLTS		X				CHECK-TORQUE TO 440 FT-LBS (DRY) AS REQUIRED
ROTATION RING GEAR		X				LUBE WITH MOBILETAC LL, OR LUBRIPLATE P/N 15263, OR EQUAL
SHEAVE BEARINGS		X				SEALED BEARING, REPLACE IF ROUGH OR LOOSE
ALL OTHER BOLTS		X				CHECK-TIGHTEN AS REQUIRED
ROTATION BEARING			X			GREASE WITH MOBILPLEX EP-2 OR EQUIVALENT @ ZERKS
ROTATION BEARING BOLTS			X			CHECK TORQUE TO 150 FT-LBS (DRY) AS REQUIRED
ROTATION GEAR BOX			X			CHECK TORQUE TO 85 FT-LBS (DRY) AS REQUIRED
ROTATION GEAR BOX				X		EP GEAR LUBE SAE 80-90
HYDRAULIC FLUID					X	DRAIN, FLUSH, AND REFILL WITH SUN 2105 HYD. OIL, SAE 5W-20
BOOM SLIDE PADS	PADS GREASED WHEN REPLACED					

FOR ADDITIONAL INFORMATION SEE:  
 1) OWNER'S MANUAL  
 2) OSHA SECTION 1910.180  
 3) ANSI B30.5-1989

# ***LUBRICATION & MAINTENANCE SCHEDULE***

## ***8406H CRANE***

**CAUTION:** Routine maintenance insures trouble-free operation and protects your investment. All warranties are void if maintenance is neglected.

### **NOTES:**

1. Use only authorized parts. Any damage or malfunction caused by the use of unauthorized parts is not covered by Warranty or Product Liability.
2. Once a bolt has been torqued to its rated capacity and then removed; the bolt should be replaced with a new one.
3. Auto Crane Company recommends that this crane be serviced per “Crane Inspection Log” P/N 999978. These logs should be filled in at the intervals noted and kept as a permanent record. Additional copies are available from your local distributor.

# **PEDESTAL ASSEMBLY**

## **8406H**

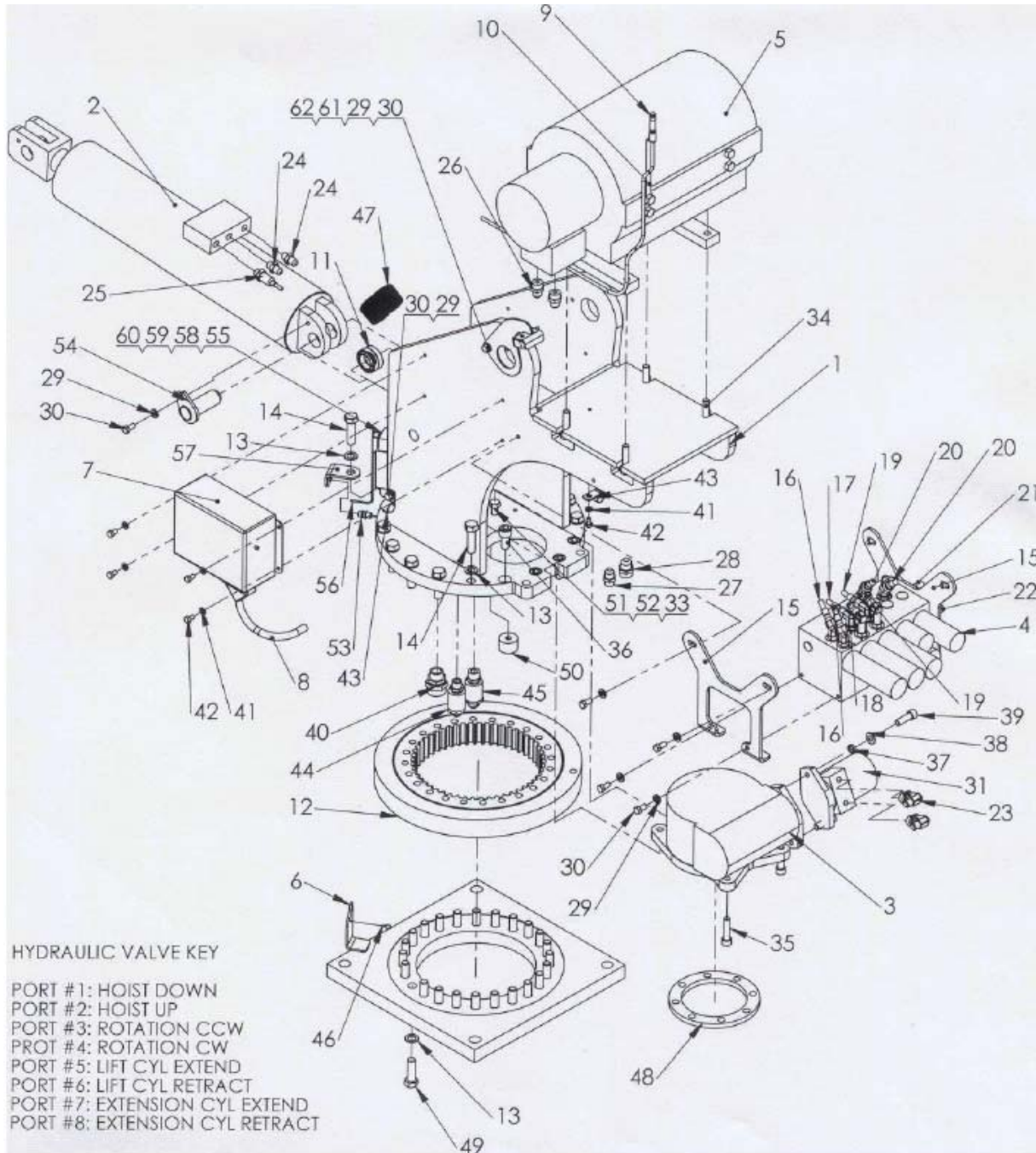

Cylinder Seal Kit - #480838001

Counterbalance Cartridge - #480188

# ***PEDESTAL ASSEMBLY***

## ***8406H***

<b>ITEM NO.</b>	<b>QTY</b>	<b>PART NO.</b>	<b>DESCRIPTION</b>
1	1	480842000	PEDESTAL WELD
2	1	480838000	CYL, LIFT
3	1	160407	GEAR BOX, ROTATION
4	1	480839000	VALVE BANK ASSY
5	1	123308	HOIST RPH4200
6	1	480857000	BASE PLATE WELD
7	1	366500001	CONTROLLER, KAR-TECH
8	1	480864000	MAIN HARNESS WIRE ASSY 6406H/8406H
9	1	366500006	CABLE, ANTENNA EXTENSION
10	1	366506000	BRACKET ANTENNA
11	1	366333	BEARING, SPHERICAL 1.25 ID
12	1	480023002	BEARING, ROTATION
13	38	023902	WASHER, 5/8 FLAT HARDENED
14	14	366393	HEX HEAD 5/8-11 X 2.5 GR8
15	2	366364	PLATE, VALVE MOUNTING
16	2	812209-022	HOSE ASSY 6 STR/90
17	1	812203-028	HOSE ASSY 6 STR
18	1	812203-030	HOSE ASSY 6 STR
19	2	480205	HOSE ASSY 6 STR X 19.25
20	2	480203	HOSE ASSY 8 STR X 24.75
21	1	812309-024	HOSE ASSY 8 STR/90
22	1	812409-024	HOSE ASSY 10 STR/90
23	2	490198	FITTING 10SAE(M)/6JIC ELBOW 90
24	2	200876	FITTING 6 SAE/6 JIC STRAIGHT 6F5OX
25	1	366477	PRESSURE TRANSDUCER
26	2	372041	FITTING 8JIC/10SAE STRAIGHT 8-10 F5OX
27	1	367145	FITTING STR 8-SAE/8-JIC
28	1	490199	FITTING STR 10-SAE/10-JIC
29	11	021100	WASHER SPLK 3/8
30	11	008400	SCW HEX HD 3/8-16 UNC X 3/4 GR 5
31	1	366440	ROTATION MOTOR
32	4	320588	WASHER FL 1/2
33	6	021500	WASHER SP LK 5/16 NC
34	4	366391	HEX HD 1/2-13 X 2 1/4
35	2	009118	SOC HD 1/2 UNC X 2
36	4	006205	SOC HD 5/8 X 1 1/4
37	2	021502	WASHER SP/LK 1/2 HI COLLAR
38	2	021601	WASHER FL 1/2
39	2	012197	SOC HD 1/2-13
40	1	370433	CORD CONNECTOR HUBBLE F-3



# ***PEDESTAL ASSEMBLY***

## ***8406H***

ITEM NO.	QTY	PART NO.	DESCRIPTION
41	5	020601	WASHER 5/16 LOCK
42	5	007401	SCW 5/16-18 X 1/2 LG
43	2	480024	MOUNT PENDANT CABLE RETAINER
44	1	366359	FITTING 8 SAE/JIC SWIVEL PS810503-8-8
45	1	366358	FITTING 10SAE/JIC SWIVEL PS810503-10-10
46	1	366423	MAGNET, PROX PICKUP
47	48	374086	NYLON HOSE SLEEVE
48	1	480011	SEAL ROTATION BOX
49	24	490306	HX HD 5/8-11 X 2.00 GR8
50	2	642908	CORD CONNECTOR
51	2	011202	SCW HX HD 1/2-20 X 2 3/4
52	2	017704	NUT HX HVY 1/2 NF
53	1	366338	HARNESS WIRE ROTATION
54	1	366492	PIN 1.25<MOD-DIAM> X 3.00 LG
55	1	366419	SWITCH, LIMIT ROTATION
56	1	480856000	LIMIT SWITCH ARM
57	1	366424	BRACKET, PROX SWITCH
58	2	020000	10 SAE FLAT WASHER
59	2	019800	10 SPLIT LOCK
60	2	330679	SCW BT HD SOCKET 10-32 X 1/2
61	1	480865000	BRACKET BOOM SWITCH
62	1	654100	SWITCH LIMIT BZ-2RW80-A2
63	2	000602	SCW PN #6 NC X 1
64	2	019600	WASHER SP LK #6
65	2	015400	NUT HX #6-32

# ***BOOM ASSEMBLY***

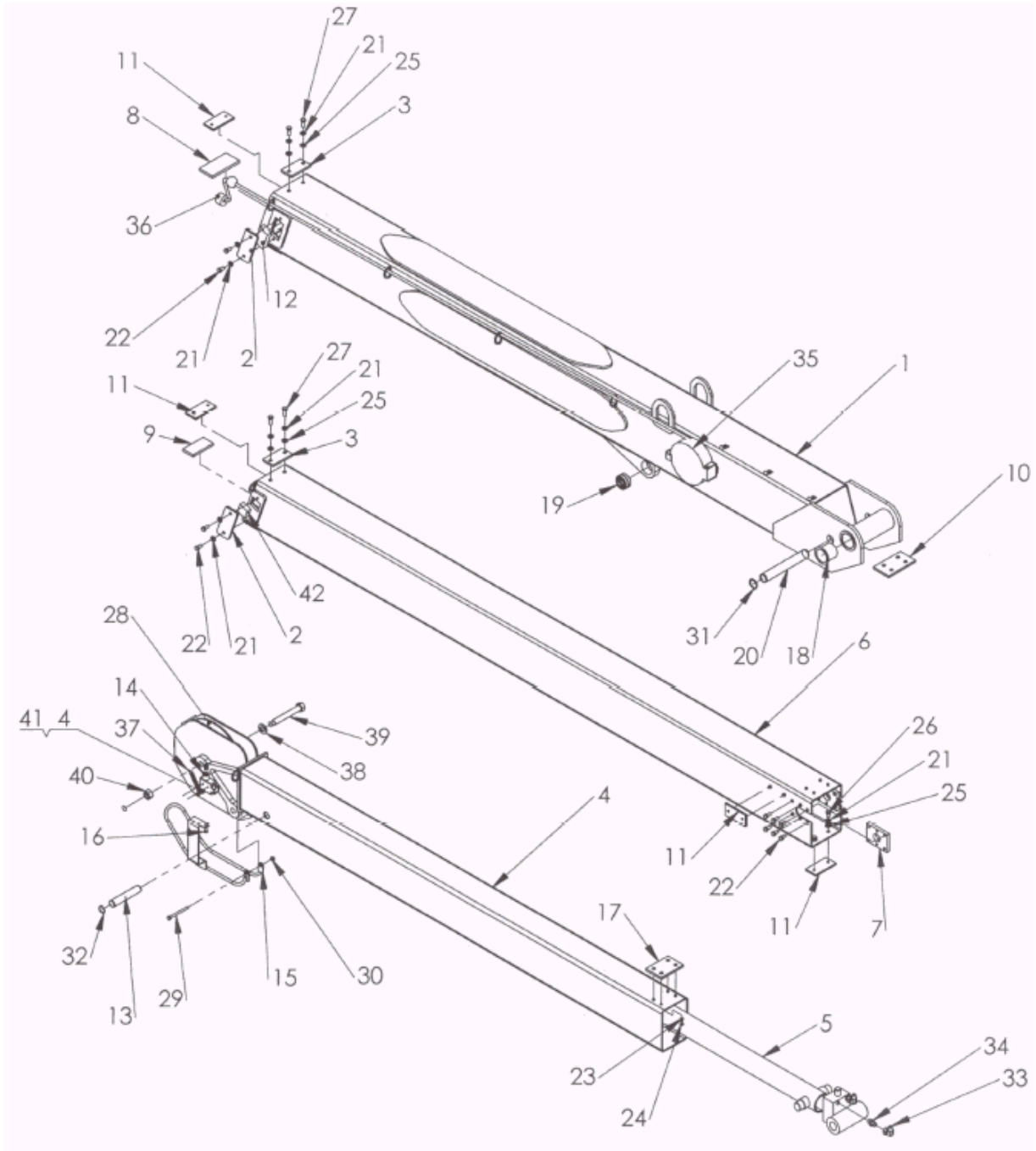

Cylinder Seal Kit - #366331001

Counterbalance Cartridge - #480188

# ***BOOM ASSEMBLY***

ITEM NO.	QTY.	PART NO.	DESCRIPTION
1	1	480831000	BOOM WELDMENT, LOWER
2	4	366385	PLATE, LOWER BOOM PAD COVER
3	2	366201	WEAR PAD 3 .75 X 2.00 X .313
4	1	480832000	BOOM WELDMENT, UPPER
5	1	366331	CYLINDER EXTENSION
6	1	366445000	BOOM WELDMENT MID
7	2	366184	RETAINER EXTENSION CYLINDER
8	1	366353	PAD WEAR 5.25 X 2.63 X .38
9	1	366499	PAD BOOM 2 X 4
10	1	366485	PAD, BOOM TOP
11	5	366483	PLATE, WEAR PAD .25 X 2 X 4
12	2	366354	WEAR PAD
13	1	366493	PIN 1<MOD-DIAM> X 5.03 LG
14	1	646900	SWITCH, LIMIT ANTI-TWO BLOCK
15	1	480834000	BAIL WELDMENT
16	1	007804	SCW HX 5/16 NC X 1 1/4 CP
17	1	366185	PAD, BOOM TOP
18	2	366394	BEARING, PIVOT
19	1	366333	BEARING, SPHERICAL 1.25 ID
20	1	366400	PIN 1.25<MOD-DIAM> X 8.063
21	18	021100	WASHER SPLK 3/8
22	20	008400	SCW HEX HD 3/8-16 UNC X 3/4 GR 5
23	8	020200	WASHER SPLIT LOCK 1/4
24	8	005406	SCW HX 1/4-28 X 1/2
25	10	021200	WASHER FL 3/8
26	6	008100	SCW HEX3/8-24 X 5/8
27	4	008800	SCW HEX 3/8-24 X 1
28	1	366198	SHEAVE ASSY 3/8
29	1	007803	SCW 5/16 NC 3 1/2 LG
30	3	016801	NUT HEX-LOCK 5/16 NC
31	2	480029	RING RETAINING
32	2	360122	RING RETAINING 5100-98
33	2	480194	FITTING 6 SWIVEL NUT ELBOW
34	2	200876	FITTING 6 SAE/6 JIC STRAIGHT 6F5OX
35	1	366973-003	CORD REEL ASSY
36	1	642908	CORD CONNECTOR
37	1	320554	SPRING RETURN
38	2	022102	WASHER FL 3/4
39	1	014400	CAPSCREW, .75-16 NF X 5
40	1	018600	NUT, NYLON LOCK .75-16 NF
41	1	016300	NUT HX NY-LOCK 1/4-20
42	2	366351	PAD, WEAR 1 1/2 X 1 1/2 X 3/4

# ROTATION GEAR BOX

P/N: 480028

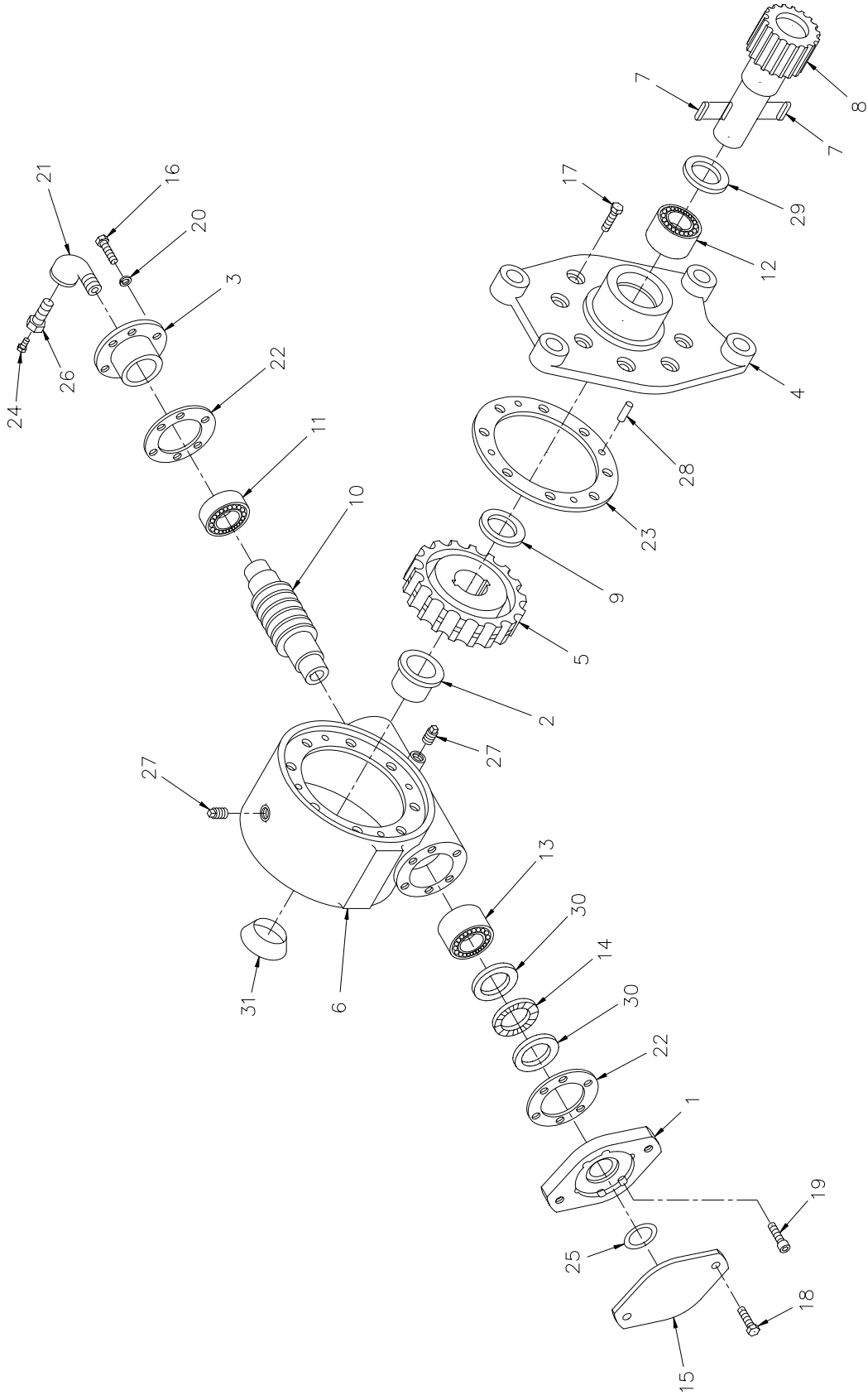

# ***ROTATION GEAR BOX***

***P/N: 480028***

<b><u>ITEM</u></b>	<b><u>QTY</u></b>	<b><u>P/N</u></b>	<b><u>DESCRIPTION</u></b>
1	1	480240	ADAPTER
2	1	480241	BUSHING
3	1	480242	CAP BEARING
4	1	480243	COVER
5	1	480244	GEAR R.H.
6	1	480237	HOUSING GEAR
7	2	480246	KEY
8	1	480247	SHAFT OUTPUT
9	1	480248	WASHER THRUST
10	1	480249	WORM R.H.
11	1	480251	BEARING BALL
12	1	480252	BEARING NEEDLE
13	1	480253	BEARING NEEDLE
14	1	480254	BEARING THRUST
15	1	480255	COVER
16	6	007400	SCREW HX HD 5/16 NC X 1
17	8	480238	SCREW HX HD 5/16 NC X 1 ¼ NYLOC HVY PATCH
18	2	011508	SCREW HX HD 1/2 NC X 3/4
19	6	480256	SCREW SOC HD 5/16 NC X 1
20	6	480258	WASHER LK 5/16 MED SECT
21	1	480259	ELL 90 DEG
22	2	480260	GASKET
23	1	480250	GASKET
24	1	480262	FITTING RELIEF
25	1	480239	O-RING
26	1	480263	REDUCER
27	2	480264	PLUG PIPE
28	4	480265	PIN DOWEL
29	1	480266	SEAL OIL
30	2	480268	WASHER THRUST
31	1	480269	PLUG EXPANSION

# HOIST ASSEMBLY 8406H

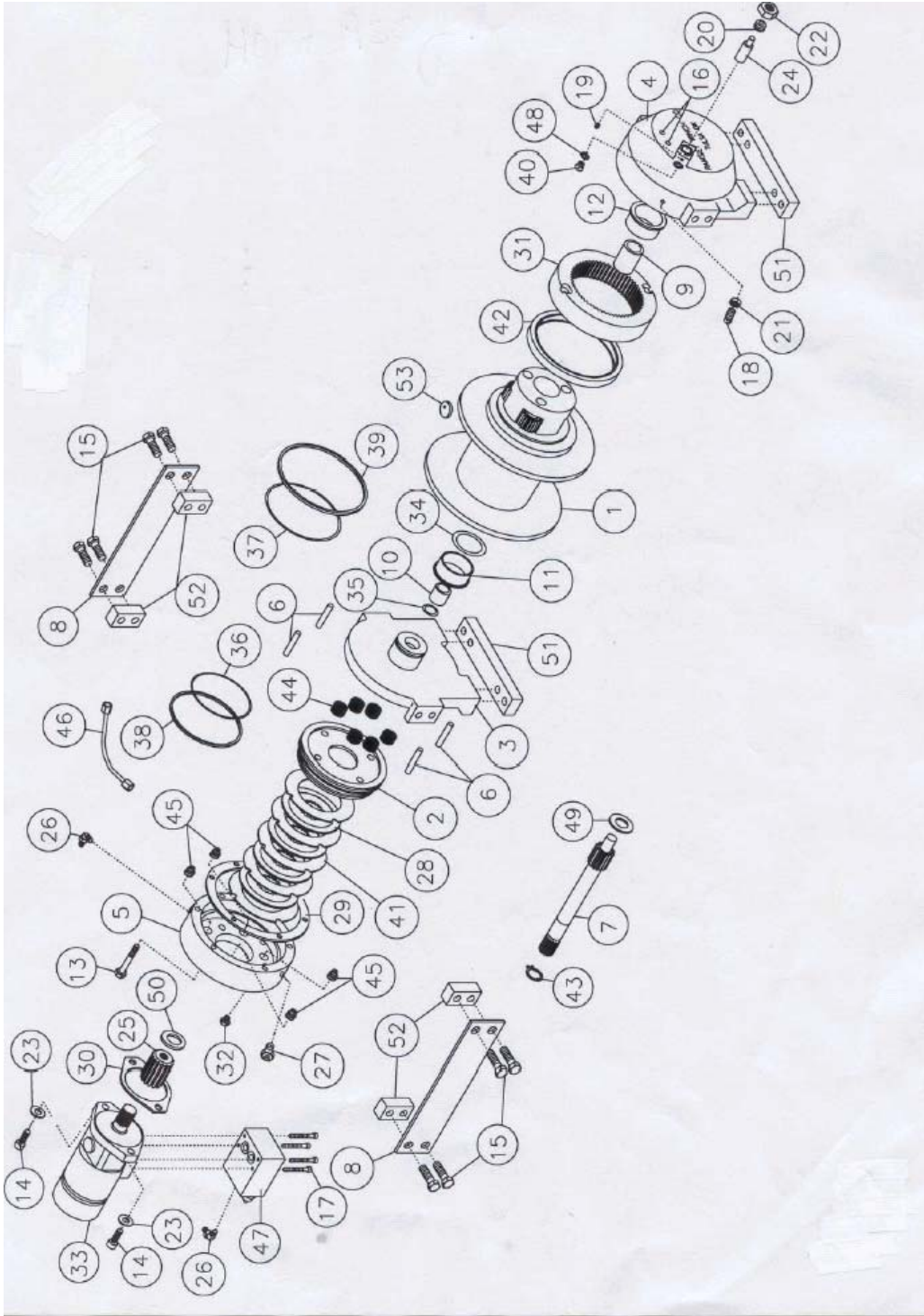

# ***HOIST ASSEMBLY***

## ***8406H - PART NO. #123308***

<u>ITEM</u>	<u>QTY</u>	<u>PART #</u>	<u>DESCRIPTION</u>
1	1	234189	DRUM ASSEMBLY
2	1	306042	PISTON, BRAKE
3	1	338300	END BEARING, MOTOR
4	1	338301	END BEARING, GEAR HOUSING
5	1	338302	HOUSING, BRAKE
6	4	346045	PIN, BRAKE
7	1	357513	INPUT SHAFT, SUN GEAR
8	2	474065	PLATE, TIE
9	1	402120	BEARING, GEAR HOUSING
10	1	402121	BEARING, MOTOR
11	1	412084	BUSHING, DRUM (MOTOR END)
12	1	412085	BUSHING, DRUM (GEAR HOUSING END)
13	6	414303	CAPSCREW, 3/8-16NC x 2 ½ LG HX HD GR5 ZINC PLTD
14	2	414948	CAPSCREW, 1/2-13NC x 1 ¼ LG SOCKET HD GR5 ZINC PLTD
15	8	414548	CAPSCREW, 1/2-13NC x 1 ½ LG HX HD GR5 ZINC PLTD
16	2	414854	CAPSCREW, 1/4-20NC x 1/2 LG RD HD SLOT ZINC PLTD
17	4	414129	CAPSCREW, 5/16-18NC x 3.0 LG SOCKET HD GR5 ZINC PLTD
18	1	414926	SETSCREW, 3/8-16NC x 1.0 LG SOCKET, NYLON
19	1	416016	SETSCREW, 1/4-20NC x 1/4 LG HEX SOCKET HD CUP

# ***HOIST ASSEMBLY***

## ***8406H - PART NO. #123308***

<u>ITEM</u>	<u>QTY</u>	<u>PART #</u>	<u>DESCRIPTION</u>
20	1	416080	SETSCREW, 5/8-18NF x 1.0 LG HEX SOCKET HD CUP
21	1	418036	NUT, JAM 3/8-16NC HEX ZINC PLTD
22	1	418088	NUT, JAM 5/8-18NF HEX ZINC PLTD
23	2	418218	LOCKWASHER, 1/2 I.D. MEDIUM SECTION ZINC PLTD
24	1	426048	PLUNGER
25	1	431015	COUPLING, MOTOR
26	2	432018	FITTING, 7/16 ELBOW (90 DEGREE)
27	1	432026	FITTING, BLEEDER
28	4	438022	DISC, BRAKE
29	1	442220	GASKET, BRAKE
30	1	442223	GASKET, MOTOR
31	1	444085	GEAR, RING
32	1	456038	FITTING, VENT
33	1	458121	MOTOR, HYDRAULIC
34	1	462046	O-RING, DRUM
35	1	462056	O-RING
36	1	462057	O-RING
37	1	462058	O-RING
38	1	462059	O-RING BACKUP



***HOIST ASSEMBLY***  
***8406H - PART NO. #123308***

<u>ITEM</u>	<u>QTY</u>	<u>PART #</u>	<u>DESCRIPTION</u>
39	1	462060	O-RING BACKUP
40	1	472052	PLUG
41	5	474111	PLATE, SEPERATOR
42	1	486080	SEAL, GEAR HOUSING
43	1	490037	SNAP RING
44	6	494110	SPRING, BRAKE
45	4	494112	SPRING
46	1	509019	TUBE ASSEMBLY
47	1	516028	VALVE, MOTOR CONTROL
48	1	518037	THRUST WASHER
49	1	518047	THRUST WASHER
50	1	518052	THRUST WASHER
51	2	362283	SPACER, FOOT MOUNTING
52	4	362284	SPACER, TIE PLATE
53	1	315004	CABLE ANCHOR

# GENERAL ASSEMBLY

## 8406H

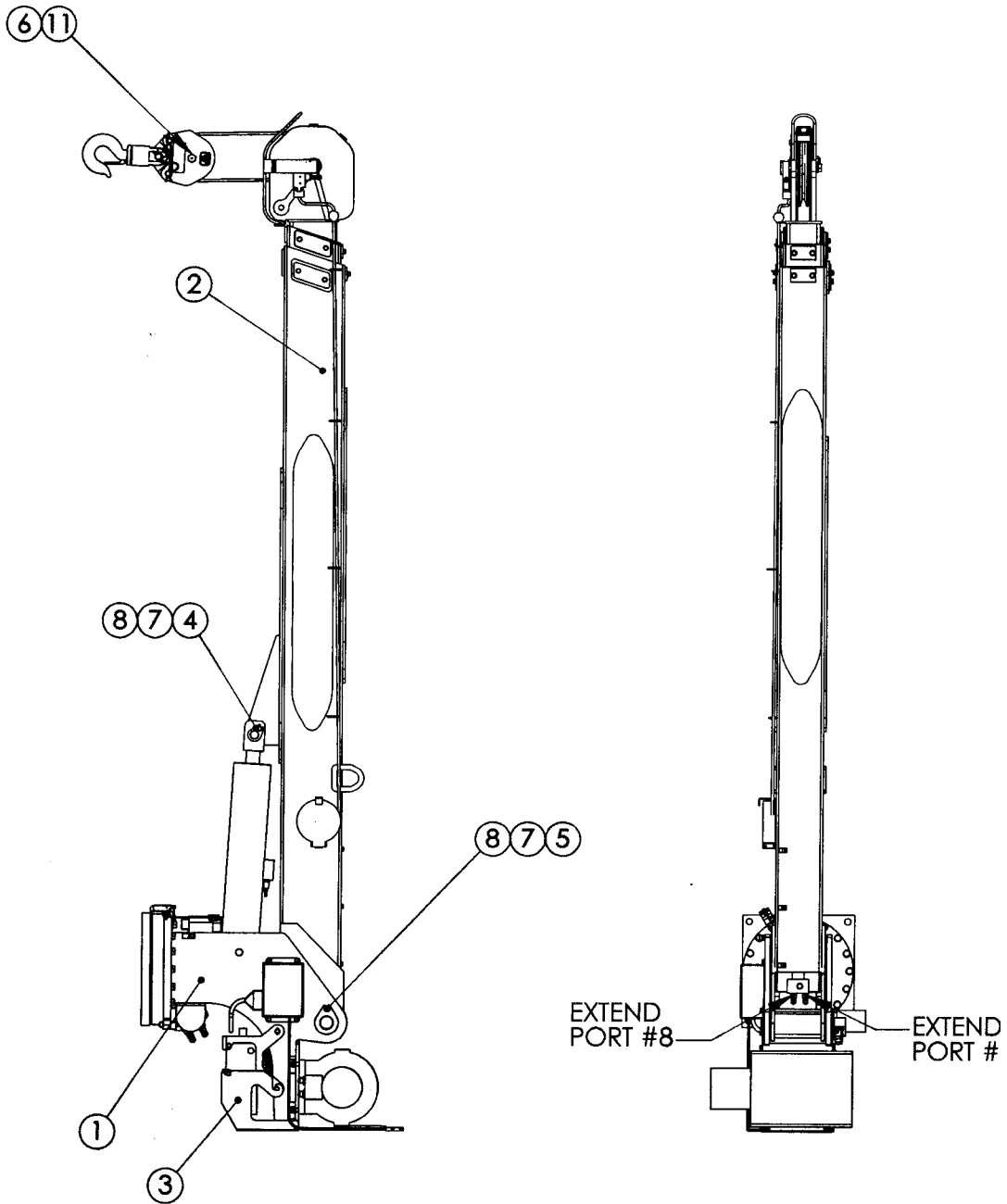

NOTE:  
ELECTRICAL SCHEMATIC DRAWING #366366  
HYDRAULIC SCHEMATIC DRAWING #366378

# ***GENERAL ASSEMBLY***

## ***8406H***

ITEM NO.	QTY.	PART NO.	DESCRIPTION
1	1	480840000	PEDESTAL ASSY
2	1	480830000	BOOM ASSEMBLY
3	1	366430000	COVER 6406
4	1	366492	PIN 1.25<MOD-DIAM> X 3.00 LG
5	1	366491	PIN 2<MOD-DIAM> X 10.5 LG
6	1	480841000	ROPE ASSY
7	2	021100	WASHER SPLK 3/8
8	2	008701	3/8-16 X 7/8 GR5 PLATED HEX CAP SCREW
9	1	480870000	SHIP KIT W/ FM CONTROL
10	1	480850000	DECAL LAYOUT
11	1	480854000	TRAVELING BLOCK

# ELECTRICAL SCHEMATIC

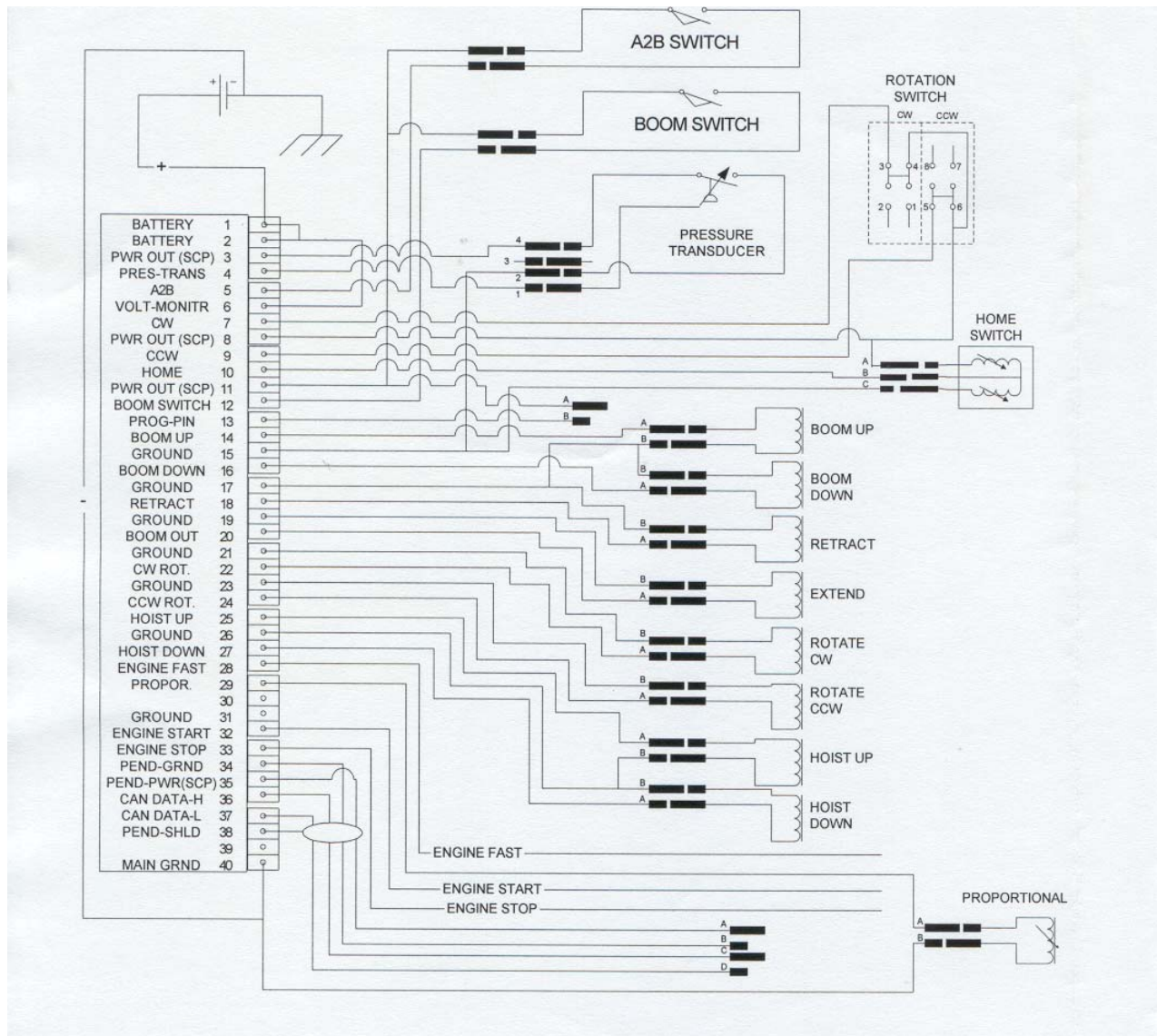

# MAIN WIRING HARNESS

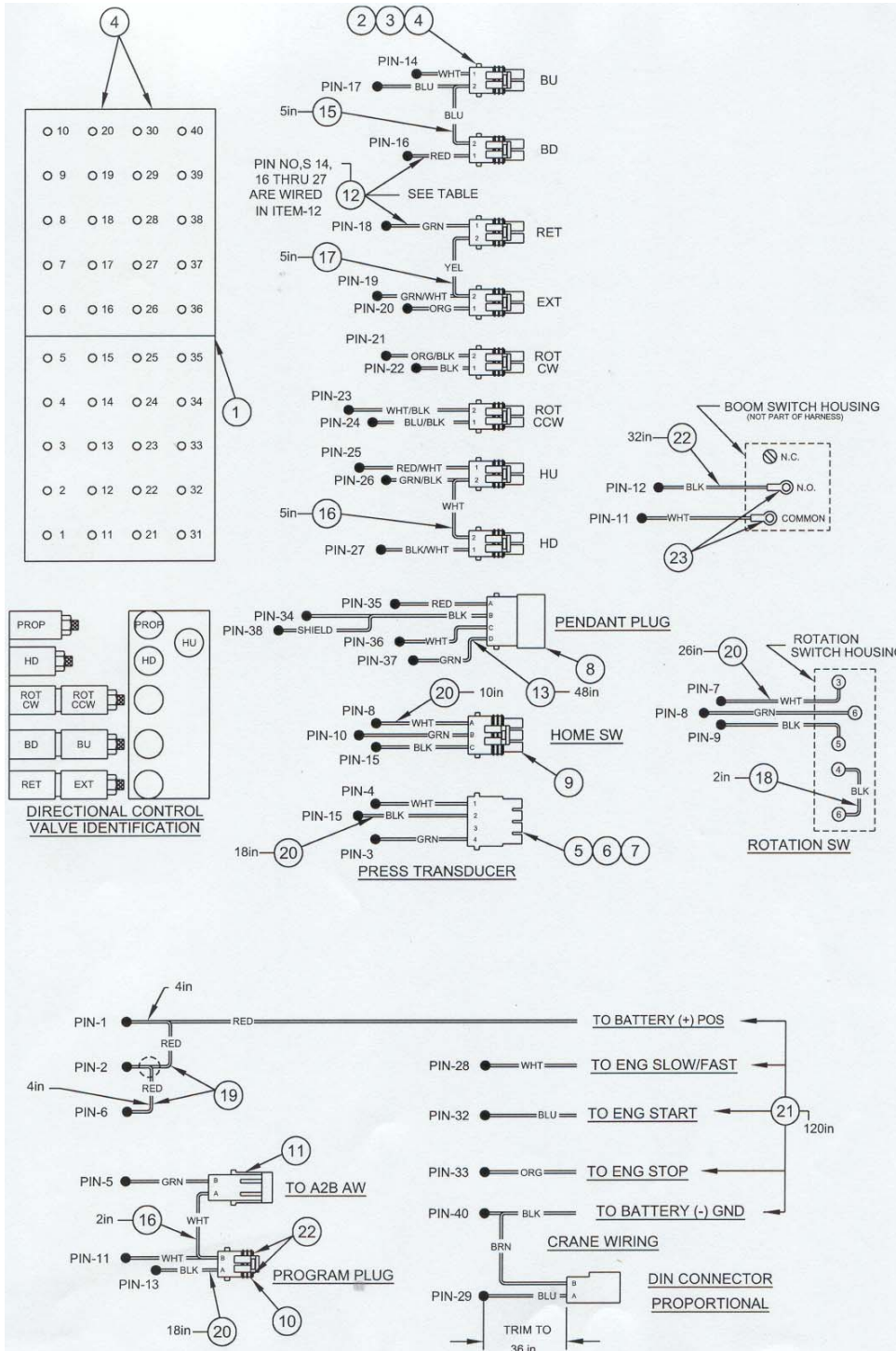

# HYDRAULIC SCHEMATIC

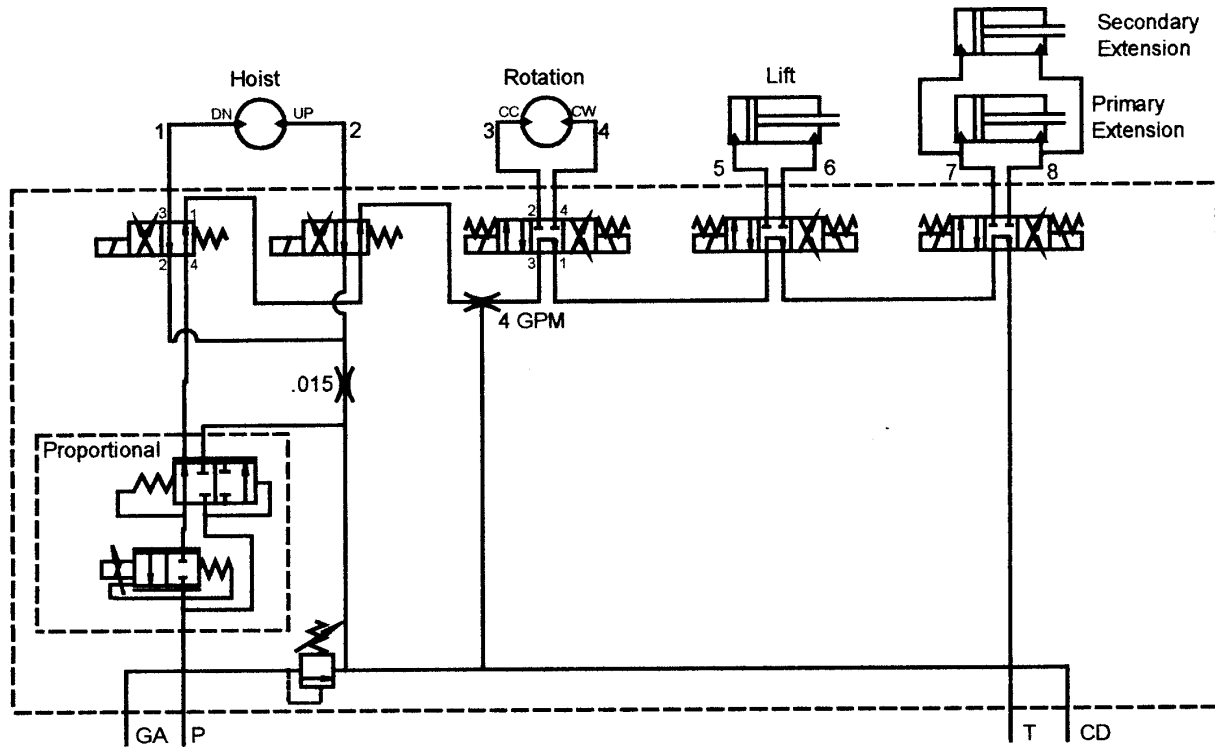

# HYDRAULIC

## 8406H

### Counterbalance Valve Adjustment

- ◆ With PTO disengaged and boom properly supported, remove the plug on the counterbalance valve. Install a pressure gauge (0-3000 PSI) into the port.
- ◆ Engage PTO and insure pump flow is 13 to 14 GPM . With no load on boom, boom up to an angle of 70 degrees. Boom down and note pressure. If pressure reading is not approximately 1300 PSI, the counterbalance valve requires adjustment.
  - To increase the CB valve setting, loosen nut and turn Allen head screw counter clockwise.
  - To reduce the CB valve setting, loosen nut and turn Allen head screw clockwise.
- ◆ Tighten nut on adjustment screw and repeat procedure if needed to obtain the proper pressure setting.
- ◆ Disengage PTO, remove the pressure gauge and install plug. Crane is now ready for operation.

### *Notice:*

- ◆ In an EMERGENCY situation when it becomes necessary to lower the boom

without flow present, the CB valve adjustment can be turned in until the boom begins to descend. Make sure the boom will lower onto a proper support. Loosen the lock nut and carefully turn adjustment screw clockwise! Count the number of turns. *Turn slowly until the boom just begins to lower, and remove hand/arm/fingers from cranes while boom is lowering.*

- ◆ Turning adjustment screw too far will cause valve to come apart on the inside. This condition is not repairable
- ◆ After boom is lowered, turn adjustment screw counter clockwise the approximate number of turns made during lowering procedure. After the problem is corrected, readjust the counterbalance valve using the procedure in this manual.

**WARNING:**  
**DO NOT TRY TO ADJUST VALVES WHILE BOOM IS MOVING. Failure to do so may result in personal injury!**

# HYDRAULIC CONTROL VALVE 8406H

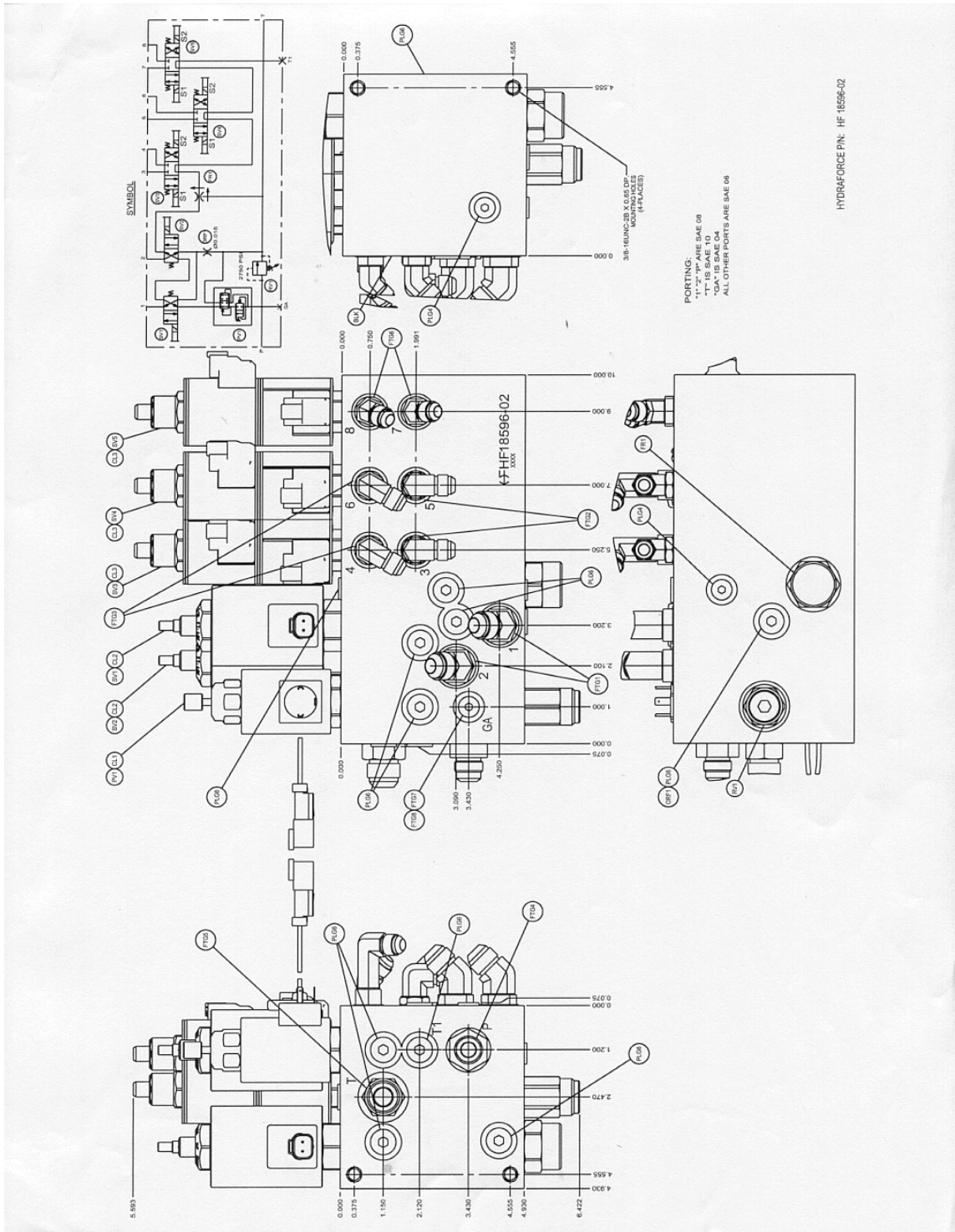



# ***HYDRAULIC CONTROL VALVE 8406H PARTS LIST***

<b>ITEM</b>	<b>QTY</b>	<b>DESCRIPTION</b>	<b>AC P/N</b>
FR1	1	FLOW CONTROL	480839002
PV1	1	PROPORTIONAL VALVE	480839003
RV1	1	RELIEF VALVE	366365004
SV3, SV4, SV5	3	CARTRIDGE VALVE	320725001
SV1, SV2	2	CARTRIDGE VALVE	480839004
CL1	1	COIL	320725005
CL2	2	COIL	480839005
CL3	6	COIL	366365001

<b>ITEM</b>	<b>QTY</b>	<b>DESCRIPTION</b>	<b>AC P/N</b>
FTG1	2	FITTING 45 8-SAE/8-JIC	374017000
FTG2	2	FITTING 90 6-SAE/6-JIC	241175000
FTG3	2	FITTING 90 6-SAE/6-JIC LONG	330645000
FTG4	1	FITTING STR 8-SAE/8-JIC	367145000
FTG5	1	FITTING STR 10-SAE/10-JIC	490199000
FTG6	2	FITTING 45 6-SAE/6-JIC	480195000



## DIAGNOSTICS

SITUATION	POSSIBLE SOLUTION
FLOW PRESENT BUT FUNCTION WILL NOT WORK	Check receiver for error code, if error code is present while function is being activated, refer to the error code section on the following page. If “NRML” appears in the code display on the receiver while the function is being activated, operate the proportional override and push or pull the override on the directional control valve to operate the function. If the function still does not operate, see the “NO FLOW” paragraph in this section.
HYDRAULIC “CHATTER”	When a hydraulic function is engaged and causes the crane to “chatter”, check for error code on receiver display, low pump pressure or air in the system.
NO FLOW OR LIMITED FLOW TO CRANE	Check for error code on receiver display (see error code section). Check for adequate oil supply in reservoir. Check operation of bypass system by operating the override on the proportional valve while operating crane. If low flow condition continues to exist when the manual override is operated, remove relief valve cartridge and check for dirt. Other possible causes for a low flow condition are: <ol style="list-style-type: none"> <li>1. Engine speed is too slow.</li> <li>2. A blocked pressure hose from pump. This condition can be identified by excessive lugging of engine and rapid overheating of oil.</li> <li>3. Collapsed or blocked suction hose to pump. This condition is usually identified by pump cavitation noise.</li> <li>4. Bad pumps: a bad pump will usually have some flow but the flow will drop off rapidly as pressure increases. This condition will cause overheating of the system. A drop of four (4) or more GPM from Zero (0) PSI to Two Thousand (2000) PSI is cause for pump investigation</li> </ol>
NO PRESSURE OR TOO LOW PRESSURE	Check the sight gauge and maintain an adequate oil level in reservoir. Make sure pressure gauge is functioning correctly. Possible relief valve stuck open. Check for excessive leakage and correct.
TOO HIGH FLOW	Make sure pump size is correct and pump speed is not too fast (Consult manufacturer's data sheet). Check or replace flow control. Check components for flow displacements. High flow may cause erratic valve operation.
TOO HIGH PRESSURE	Make sure pressure relief valve is correctly set.

## CAUTION

**The Auto Crane 8406H series cranes are manufactured with a standard overload protection system to prevent structural damage to the crane. When the crane load rating is exceeded, main boom down, extend out, and hoist up will not function. These operations cannot be used again until the load on the crane is reduced. Also, the main boom elevation will be limited in it's operation as the crane becomes overloaded. Attempting to raise the main boom with a load greatly exceeding the crane rating will open the main relief valve resulting in no boom movement. This problem can be resolved by moving the load closer to the crane pedestal, or reducing the load.**

# ***CONTROLLER DIAGNOSTICS***

**CODE:** EC01

**DESCRIPTION:** Signal problem

**POSSIBLE CAUSE(S):**

**POSSIBLE SOLUTION(S):**

function is activated. If light does not come on, make sure transmitter is on. If light comes on and red low battery light is on, charge unit. If transmitter is plugged in as a pendant and transmit light comes on but code remains, check cable connections and cable.

**CODE:** EC02

**DESCRIPTION:** Boom up

**POSSIBLE CAUSE(S):** Short or open connection on boom up output.

**POSSIBLE SOLUTION(S):** Check plug in boom up solenoid on hydraulic control valve. Check wires for damage that could cause break or short.

**CODE:** EC03

**DESCRIPTION:** Boom down

**POSSIBLE CAUSE(S):** Short or open connection on boom down output.

**POSSIBLE SOLUTION(S):** Check plug in boom down solenoid on hydraulic control valve. Check wires for damage that could cause break or short.

**CODE:** EC04

**DESCRIPTION:** Boom in (retract)

**POSSIBLE CAUSE(S):** Short or open connection on boom in output.

**POSSIBLE SOLUTION(S):** Check plug in boom in solenoid on hydraulic control valve. Check wires for damage that could cause break or short.

# ***CONTROLLER DIAGNOSTICS***

**CODE:** EC05

**DESCRIPTION:** Boom out (extend)

**POSSIBLE CAUSE(S):** Short or open connection on boom out output.

**POSSIBLE SOLUTION(S):** Check plug in boom out solenoid on hydraulic control valve. Check wires for damage that could cause break or short.

**CODE:** EC06

**DESCRIPTION:** Rotate CW

**POSSIBLE CAUSE(S):** Short or open connection on rotate CW output.

**POSSIBLE SOLUTION(S):** Check plug in rotate CW solenoid on hydraulic control valve. Check wire for damage that could cause break or short.

**CODE:** EC07

**DESCRIPTION:** Rotate CCW

**POSSIBLE CAUSE(S):** Short or open connection on rotate CCW output.

**POSSIBLE SOLUTION(S):** Check plug in rotate CCW solenoid on hydraulic control valve. Check wire for damage that could cause break or short.

**CODE:** EC08

**DESCRIPTION:** Hoist up

**POSSIBLE CAUSE(S):** Short or open connection on hoist up output.

**POSSIBLE SOLUTION(S):** Check plug in hoist up solenoid on hydraulic control valve. Check wire for damage that could cause break or short.

# ***CONTROLLER DIAGNOSTICS***

**CODE:** EC09

**DESCRIPTION:** Hoist down

**POSSIBLE CAUSE(S):** Short or open connection on hoist down output.

**POSSIBLE SOLUTION(S):** Check plug in hoist down solenoid on hydraulic control valve. Check wire for damage that could cause break or short.

**CODE:** EC10

**DESCRIPTION:** Incorrect ID

**POSSIBLE CAUSE(S):**

**POSSIBLE SOLUTION(S):** Confirm that transmitter being used is for use with this unit. Follow “Transmitter/Receiver Sync.” procedure in the transmitter operation section of this manual.

**CODE:** EC15

**DESCRIPTION:** Pressure sensor

**POSSIBLE CAUSE(S):** Pressure sensor problem.

**POSSIBLE SOLUTION(S):** Check plugs and wires coming from pressure sensor mounted in the lift cylinder counterbalance valve.

**CODE:** EC16

**DESCRIPTION:** Trigger

**POSSIBLE CAUSE(S):** Transmitter trigger problem.

**POSSIBLE SOLUTION(S):** Check trigger for damage, contamination or incorrect adjustment.

# ***CONTROLLER DIAGNOSTICS***

**CODE:** EC17

**DESCRIPTION:** Trigger logic error

**POSSIBLE CAUSE(S):**

**POSSIBLE SOLUTION(S):** Confirm that trigger is released and returned to full off position, activate function and reactivate trigger.

**CODE:** EC18

**DESCRIPTION:** E-STOP

**POSSIBLE CAUSE(S):** E-STOP activated.

**POSSIBLE SOLUTION(S):** Push E-STOP will power the unit off.

**CODE:** EC19

**DESCRIPTION:** Rotation error

**POSSIBLE CAUSE(S):** Rotation proximity switch error.

**POSSIBLE SOLUTION(S):** Check plugs and wiring. Check for debris around switch or magnet.

**CODE:** LBV

**DESCRIPTION:** Low battery

**POSSIBLE CAUSE(S):** Low battery power to receiver.

**POSSIBLE SOLUTION(S):** Check connections to the battery. Charge battery. NOTE: It is recommended that the crane be powered off if battery is charged with battery charger.

# ***CONTROLLER DIAGNOSTICS***

**CODE:** OVL1

**DESCRIPTION:** Over load 1

**POSSIBLE CAUSE(S):** Pressure overload with extend or hoist activated.

**POSSIBLE SOLUTION(S):** Retract boom, hoist down or otherwise alleviate overload condition. Refer to load chart for rated load. If the error persists with seemingly t cylinder psi. Pressure sensor can give false readings if not properly grounded.

**CODE:** OVL2

**DESCRIPTION:** Over load 2

**POSSIBLE CAUSE(S):** Pressure overload with boom up or down activated.

**POSSIBLE SOLUTION(S):** Retract boom, hoist down or otherwise alleviate overload condition. Refer to load chart for rated load. If the error persists with seemingly light loads, install pressure gage in plugged port of lift cylinder counterbalance valve to confirm pressures in excess of 2,750 psi. Pressure sensor can give false readings if not properly grounded.

**CODE:** A2B

**DESCRIPTION:** Anti-two block

**POSSIBLE CAUSE(S):** Anti-two block switch tripped.

**POSSIBLE SOLUTION(S):** Check switch, if not mechanically tripped, check continuity across switch at plug. If switch has continuity check voltage across transmitter side of A2B plug. If low voltage is read, power to the A2B switch,

# ***CONTROLLER DIAGNOSTICS***

**CODE:** RSBM

**DESCRIPTION:** Raise boom

**POSSIBLE CAUSE(S):** Pressure sensor is reading less than 80 psi.

**POSSIBLE SOLUTION(S):** Raise boom to ensure it is not resting on other structure and the lift cylinder is not bottomed out.

**CODE:** HOME

**DESCRIPTION:** Home position

**POSSIBLE CAUSE(S):** Crane is pointed forward ready to be stowed.

**POSSIBLE SOLUTION(S):** RSBM condi-

**CODE:** NRML

**DESCRIPTION:** Normal operating mode

**POSSIBLE CAUSE(S):** Crane is functioning properly.

**POSSIBLE SOLUTION(S):** This is not an error. It is a standard normal operation readout.

**CODE:** BLMT

**DESCRIPTION:** Boom Limit

**POSSIBLE CAUSE(S):** Boom has reach maximum elevation.

**POSSIBLE SOLUTION(S):** This is not an error. It only indicates boom position.



# *TRANSMITTER / RECEIVER SYNCHRONIZATION*

1. Power on the transmitter and receiver.
2. Locate the program plug on the crane. This will be the unused plug near where the cord reel plugs into the wire harness.
3. Using a jumper wire, as shown below, connect the two contacts in the plug.
4. While the jumper is installed, activate a function on the transmitter.  
**Note:** The crane must be electrically powered but it is not necessary to supply hydraulic power to complete synchronization.
5. Remove the jumper wire.  
**Important:** The jumper wire should not be left installed. Doing so could cause the crane to be operated by another transmitter.

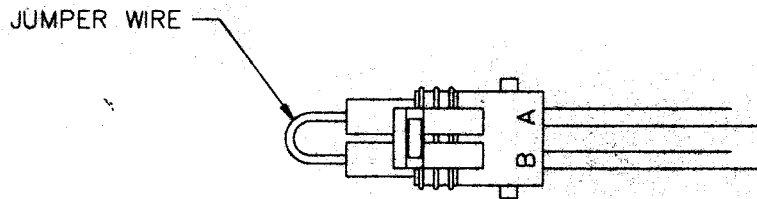

# ***REMOTE/PENDANT PARTS AND ACCESSORIES***

<u>Component</u>	<u>Part Number</u>
Receiver	366500001
Transmitter	366500002
Pendant Cable	366500004
Antenna	366500005
Antenna Extension Cable	366500006
Cigarette Lighter Charger	366504000
A/C Charger	366505000
Palm Diagnostic Unit	366510000

# VALVE OVERRIDE OPERATION

In the event that the electrical control system fails the crane can be operated using the manual overrides on the hydraulic control valve.

The overrides operate as follows:

1. Proportional - increase flow by turning clockwise.
2. Extend/Retract, Boom Up/Down, Rotate CW/CCW – Push to operate boom down, pull to operate boom up etc. See graphic below.
3. Hoist Up/Down – Push in, rotate counterclockwise, release.

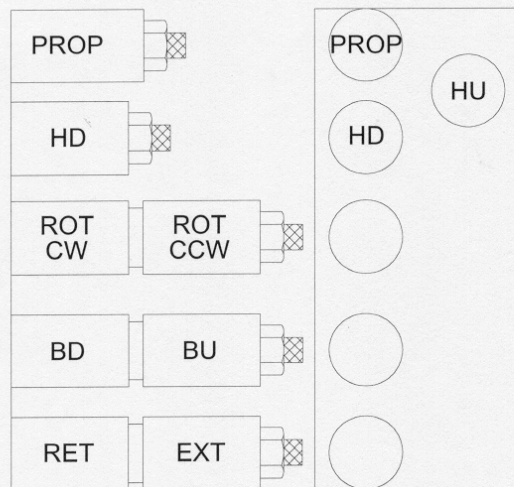

**DIRECTIONAL CONTROL  
VALVE IDENTIFICATION**

# ***FUSE INFORMATION***

## ***8406H***

**NOTE:** Always turn power to crane off before removing fuse.

**Fuse is on ground circuit. The fuse can be replaced with a 7.5 amp fuse.**

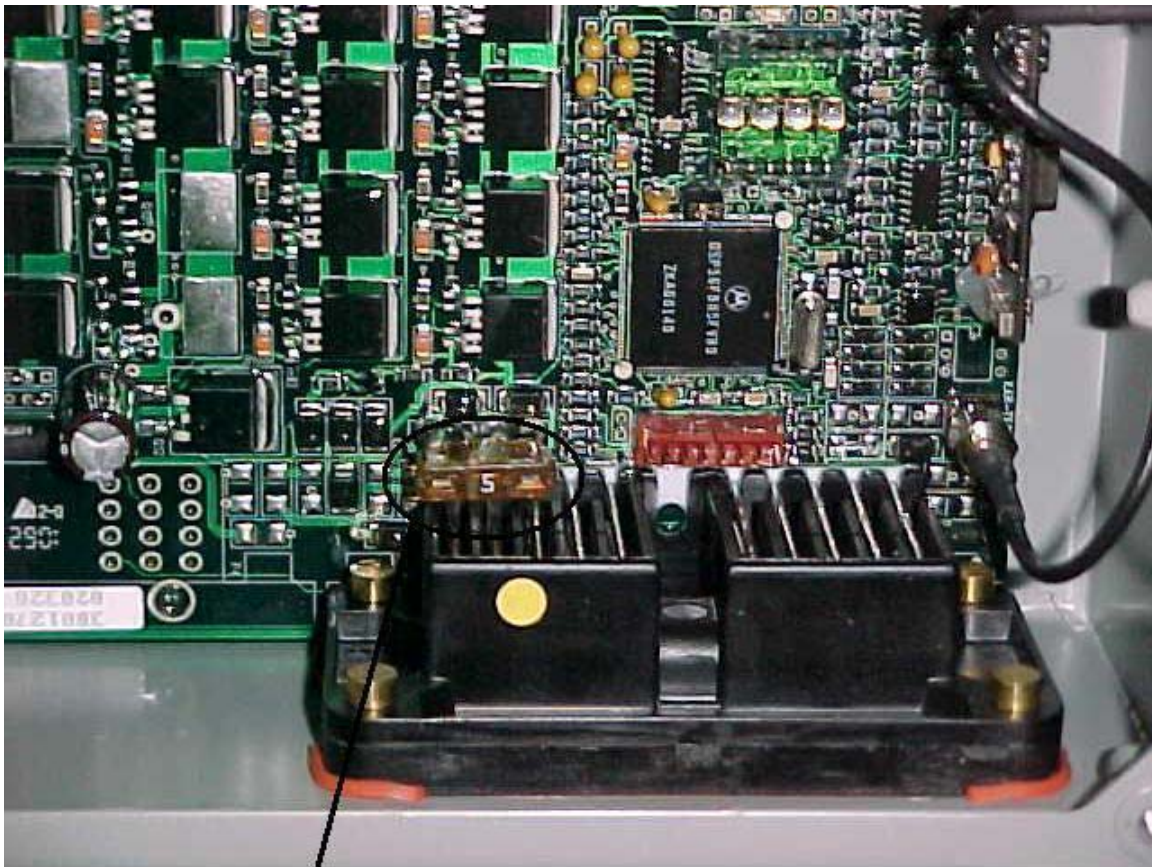

**FUSE**

# LOAD CHART

## 8406H

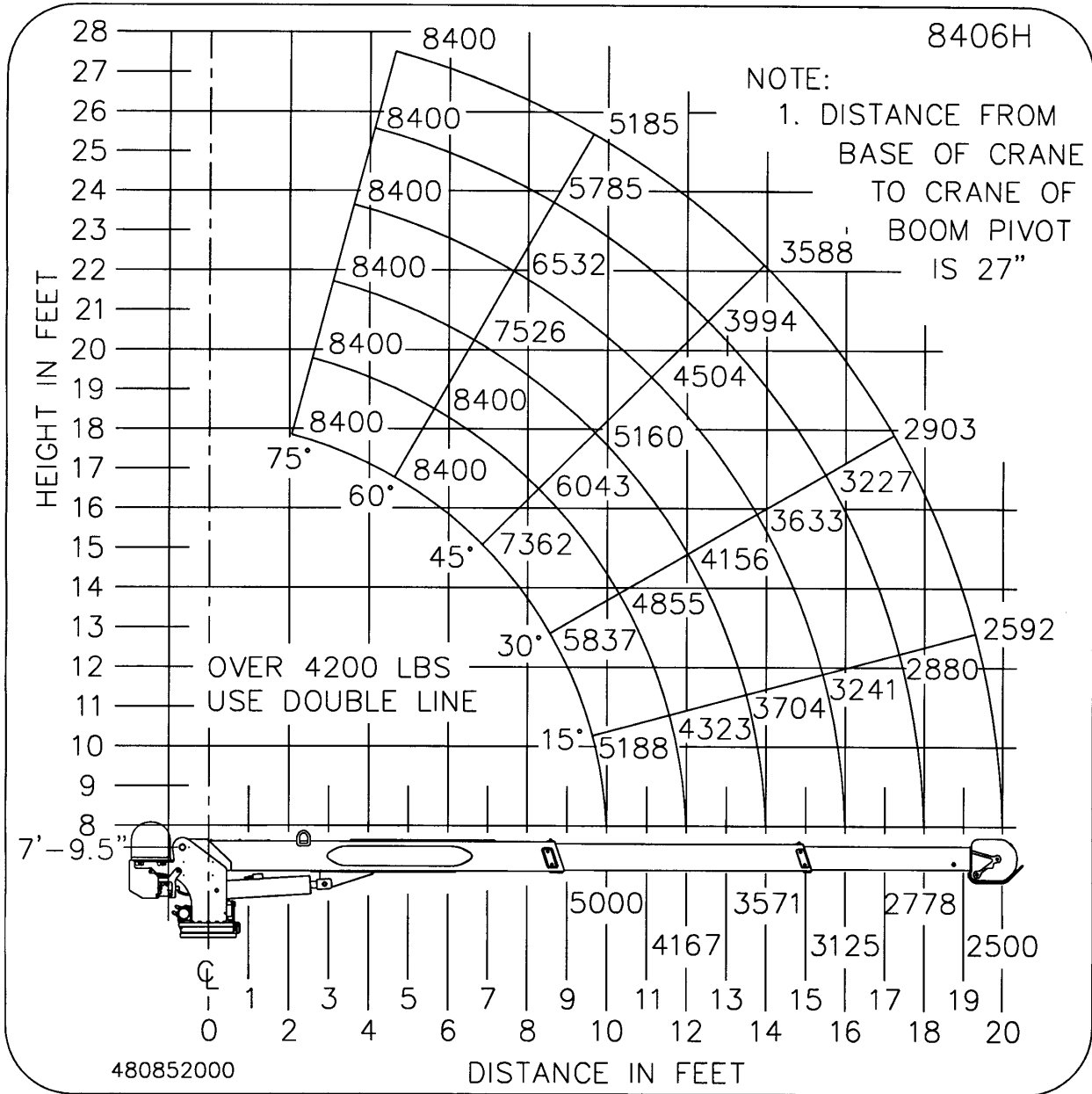

# ***SUPPLIMENTAL INFORMATION***

## ***HARD WIRED SERIES***

The following section refers to hardwire specific information only. Refer to the previous sections for information common to both crane versions.

# GENERAL ASSEMBLY

## 8406H HARD WIRED SERIES

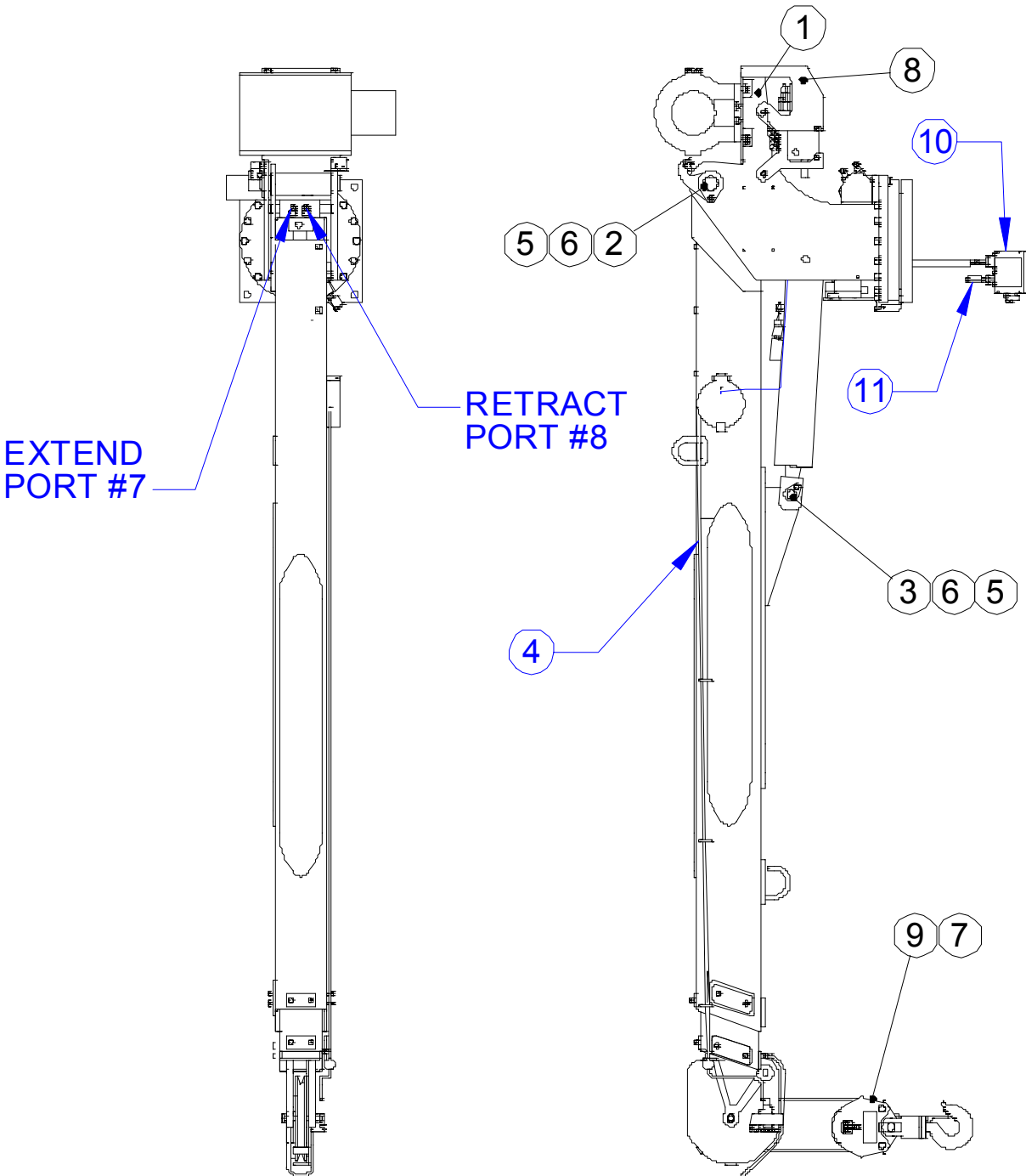

***GENERAL ASSEMBLY  
8406H HARD WIRED SERIES***

ITEM NO.	QTY.	PART NO.	DESCRIPTION
1	1	480821000	PEDESTAL ASSY, 8406H HARD WIRED
2	1	366491	PIN 2 DIA X 10.5 LG
3	1	366492	PIN 1.25 DIA X 3.00 LG
4	1	480830000	BOOM ASSEMBLY
5	2	021100	WASHER SPLK 3/8
6	2	008701	SCW HX 3/8 UNC X 7/8 GR5
7	1	480841000	ROPE ASSY
8	1	366430000	COVER 6406
9	1	*480854000	TRAVELING BLOCK ASSY 8406H
10	1	*366520000	JUNCTION BOX ASSEMBLY
11	1	*366466000	WIRE HARNESS, TRUCK FUNCTIONS

\* included in crane ship kit, ref P/N: 480882000



# ***MOUNTING AND INSTALLATION***

## ***8406H HARD WIRED SERIES***

1. Check to make sure the following items are with your crane.

ITEM	QTY	PART NO.	DESCRIPTION
1	1	480854000	TRAVELING BLOCK, 8406H
2	1	480899	Owners Manual
3	4	015104000	Bolt 7/8 NF x 5" Grade 8 (4 Req'd)
4	4	022200000	Washer Split Lock 7/8 (4 Req'd)
5	1	680040000	Pendant assembly
6	1	366466000	WIRE HARNESS, TRUCK FUNCTIONS
7	1	366520000	JUNCTION BOX ASSEMBLY
8	4	018900	NUT, HEX 7/8 NF
9	1	320355	POWER RELAY
10	1	480689	FUSE 15 AMP TIME DELAY
11	1	480688	FUSE HOLDER WATERPROOF
12	120"	800596	CONDUCTOR 16GA YELLOW X 120 INCHES LONG
13	6	634401	WIRE TIE 7 INCHES LONG
14	6	750738	WIRE TIE STICK ON RETAINER
15	5	320357	CONNECTOR FEM SPD
16	1	320363	PLUG RELAY
17	1	480852000	LOAD CHART DECAL, 8406H
18	1	340638	CONDUCTOR POWER

2. Pressure and return hoses are not furnished with this crane. The hoses must be provided by the installer and the lengths determined at installation.

#### REQUIREMENTS FOR INSTALLATION USING 10 GALLON RESERVOIR

- A. RETURN LINE FROM CRANE TO RESERVOIR (IN COMPARTMENT): -10 SAE 100R2 (OR EQUIVALENT). HOSE LENGTH IS DETERMINED BY INSTALLER. RETURN LINES LONGER THAN 6 FEET SHOULD BE SIZE -12. HOSE END FITTINGS ARE -10 JIC FEMALE SWIVEL (CRANE END) AND -10 JIC FEMALE SWIVEL (RESERVOIR END).
- B. PRESSURE LINE FROM PUMP TO CRANE: -8 SAE 100R2 (OR EQUIVALENT). HOSE LENGTHS IS DETERMINED BY INSTALLER. HOSE END FITTINGS ARE BOTH -8 JIC FEMALE SWIVEL.

#### NOTE:

REFER TO OWNERS MANUAL FOR ADDITIONAL INSTALLATION INFORMATION.

#### **CAUTION – FAILURE TO USE CLEAN HYDRAULIC HOSES AND COMPONENTS MAY CONTAMINATE THE CRANE AND HYDRAULIC SYSTEM AND VOID WARRANT**

3. Crane must be provided with a flow of 13 gallons per minute and a pressure of 2,750PSI. Excess flow will cause erratic operation, and too little flow will cause poor crane operation.
4. Vehicle should meet minimum GVW rating of 20,500 pounds.
5. The vehicle MUST be equipped with an engine speed control and tachometer.
6. Make sure mounting surface is properly reinforced to withstand 50,000 ft-lb capacity loading of crane and that outriggers are used to provide total stability for the truck.
7. A 13 ½" dia. Hole should be cut out of mounting location (centered with mounting blots) for access to lower ring gear bolts and hydraulic connections.
8. Make sure the mounting blots are 7/8" dia, grade 8. Torque bolts to 440 ft-lbs (dry).
9. When crane is not in operation, a boom support should always be used. Traveling block should be connected to hood loop.
10. Install junction box inside compartment safe from weather and contamination.

# ***MOUNTING AND INSTALLATION***

## ***8406H HARD WIRED SERIES***

### 11. Electrical hookup:

Wiring (cable from junction box):

- A. CONNECT THE BLACK WIRE TO THE BATTERY NEGATIVE (GROUND).
- B. CONNECT THE RED WIRE TO FUSED 12VDC POWER. 12VDC POWER SHOULD BE SUPPLIED THROUGH A DEDICATED SWITCH THAT IS POWERED ONLY WHEN THE IGNITION SWITCH IS ON. A RELAY IS PROVIDED TO SEPARATE POWER SOURCES.
- C. OPTIONALLY, USE THE WHITE WIRE FOR ENGINE FAST/SLOW.
- D. OPTIONALLY, USE THE BLUE WIRE FOR ENGINE START.
- E. OPTIONALLY, USE THE ORANGE WIRE FOR ENGINE STOP.
- F. OPTIONALLY, USE THE GREEN WIRE FOR AUXILIARY.

**WARNING!** FAILURE TO CORRECTLY PLUMB AND WIRE CRANE CAN CAUSE INADVERTENT OPERATION AND DAMAGE TO CRANE AND/OR PERSONEL!

- 12. Once crane and plumbing are installed on the truck, fill the reservoir to top of sight glass (mobile DTE 13 or equal). Before operating crane, connect together the pressure and return hoses going to base of crane using 10-8 JIC union and engage PTO with engine running. Allow oil to circulate for 15 to 20 minutes. This will flush contaminants from the system back to the return line filter. Operate all cylinders to full extension and retraction a minimum of six times, to bleed air from system. Return all cylinders to the stored position and disengage PTO. Refill reservoir to top sight glass. To ensure 8 gallons per minute (GPM), install an in-line flow meter between the crane and the reservoir in the return hose.
- 13. Load test the crane to ensure proper functioning and truck stability
- 14. Make certain the owner's manual is delivered to the customer.
- 15. For additional help: call the service department at the Auto Crane Company. (918) 836-0463 (Tulsa, Oklahoma)

### **WARNING**

**FEDERAL LAW** (49 CFR PART 571) REQUIRES THAT THE FINAL STAGE MANUFACTURER OF A VEHICLE CERTIFY THAT HE VEHICLE COMPLIES WITH ALL APPLICABLE FEDERAL REGULATIONS. ANY MODIFICATIONS PERFORMED ON THE VEHICLE PRIOR TO THE FINAL STAGE ARE ALSO CONSIDERED INTERMEDIATE STAGE MANUFACTURING AND MUST BE CERTIFIED AS TO COMPLIANCE. THE INSTALLER OF THIS CRANE AND BODY IS CONSIDERED ONE OF THE MANUFACTURERS OF THE VEHICLE. AS SUCH A MANUFACTURER, THE INSTALLER IS RESPONSIBLE FOR COMPLIANCE WITH ALL APPLICABLE FEDERAL AND STATE REGULATIONS, AND IS REQUIRED TO CERTIFY THAT THE VEHICLE IS IN COMPLIANCE.

**IT IS THE FURTHER RESPONSIBILITY** OF THE INSTALLER OF THE CRANE TO COMPLY WITH THE OSHA TRUCK CRANE STABILITY REQUIREMENTS AS SPECIFIED BY 29 CFR PART 1910.180 (C) (1).

# ELECTRICAL SCHEMATIC HARD WIRED CRANE

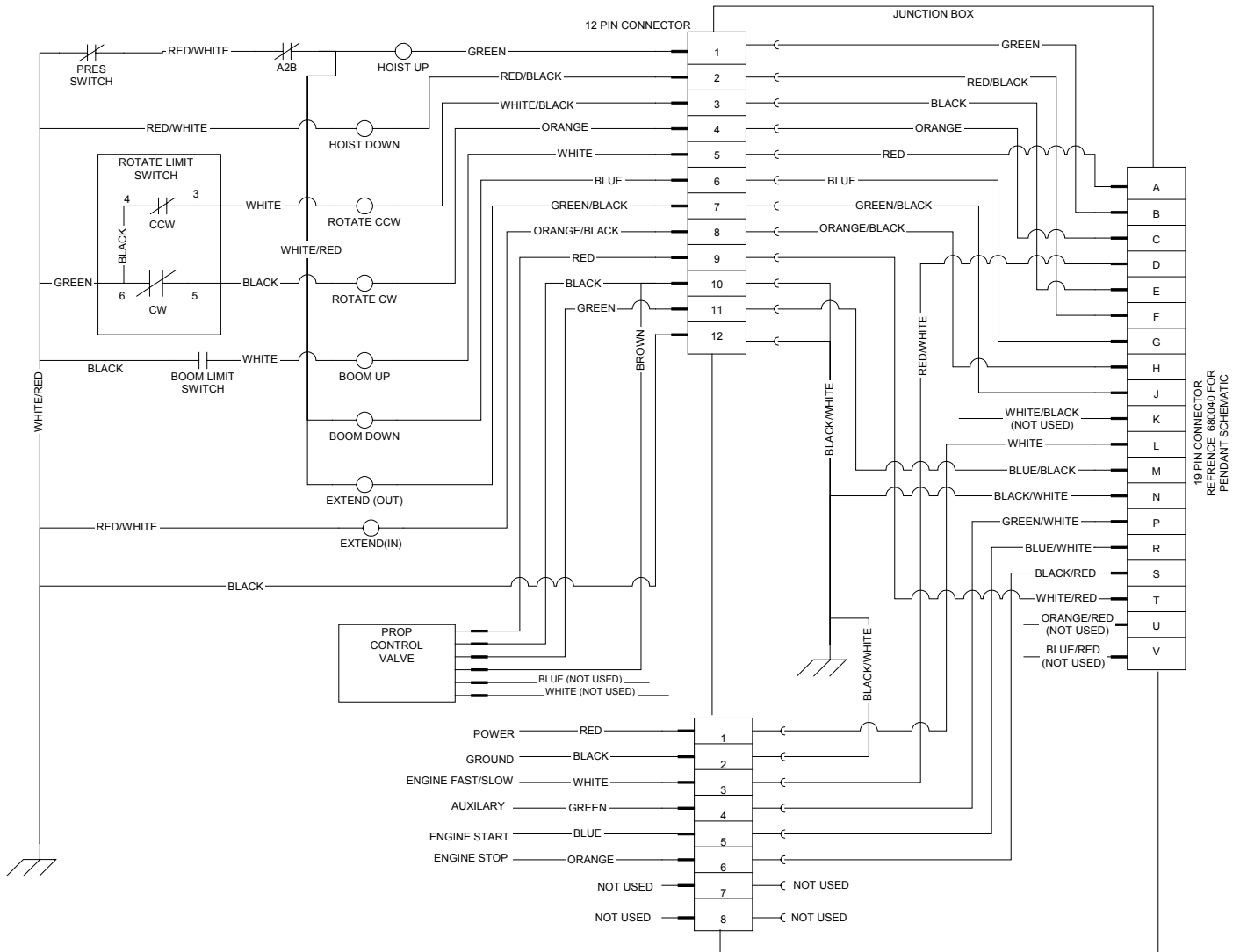

# *PEDESTAL ASSEMBLY*

## *8406H HARD WIRED SERIES*

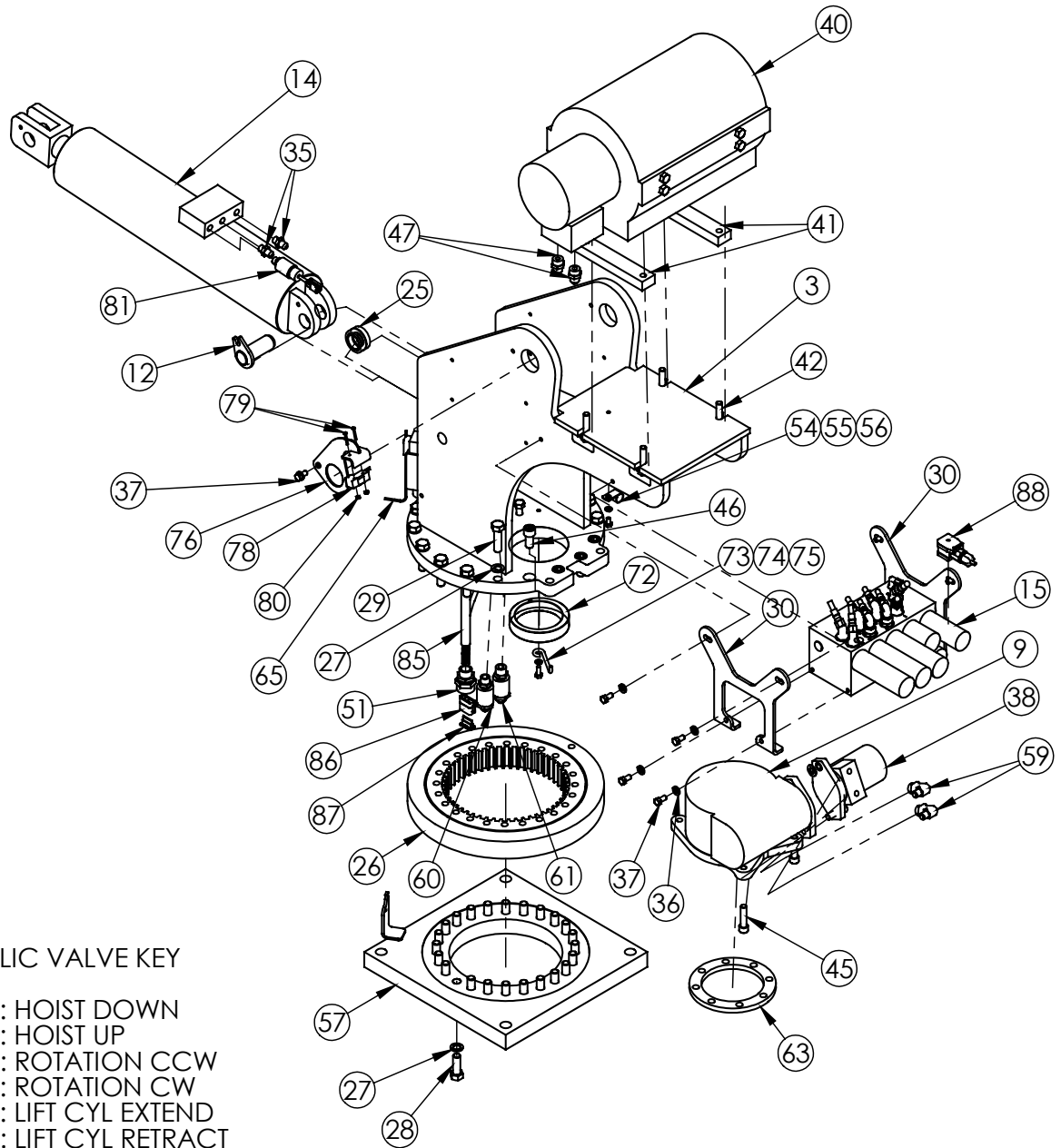

### HYDRAULIC VALVE KEY

- PORT #1: HOIST DOWN
- PORT #2: HOIST UP
- PORT #3: ROTATION CCW
- PORT #4: ROTATION CW
- PORT #5: LIFT CYL EXTEND
- PORT #6: LIFT CYL RETRACT
- PORT #7: EXT CYL EXTEND
- PORT #8: EXT CYL RETRACT

CYLINDER SEAL KIT: 480838001  
 COUNTER BALANCE CARTRIDGE: 480188000

# ***PEDESTAL ASSEMBLY***

## ***8406H HARD WIRED SERIES***

ITEM NO.	QTY.	PART NO.	DESCRIPTION
1	1	480847000	PEDESTAL WELD
2	1	160407	GEAR BOX, ROTATION
3	1	366492	PIN 1.25 DIA X 3.00 LG
4	1	480838000	CYL, LIFT
5	1	366365000	VALVE CONTROL ASSY
6	1	366333	BEARING, SPHERICAL 1.25 ID
7	1	480023002	BEARING, ROTATION
8	38	23902	WASHER, 5/8 FLAT HARDENED
9	24	12198	CAPSCREW 5/8-11 X 1.75 GR8
10	14	490171	CAPSCREW 5/8-11 X 2.25 GR8
11	2	366364	PLATE, VALVE MOUNTING
12	2	812209-022	HOSE ASSY 6 STR/90
13	2	480205	HOSE ASSY 6 STR X 19.25
14	1	812203-028	HOSE ASSY 6 STR
15	1	812203-030	HOSE ASSY 6 STR
16	2	200876	FITTING 6 SAE/6 JIC STRAIGHT 6F50X
17	10	21100	WASHER SPLK 3/8
18	10	8400	SCW HEX HD 3/8-16 UNC X 3/4 GR 5
19	1	366440	ROTATION MOTOR
20	2	480202	HOSE ASSY 8 STR X 21.5
21	1	123307	HOIST RPH4201233080
22	4	320588	WASHER FL 1/2
23	6	21500	WASHER SP LK 1/2
24	4	366391	HEX HD 1/2-13 X 2 1/4
25	2	9118	SOC HD 1/2 UNC X 2
26	4	6205	SOC HD 5/8 X 1 1/4
27	2	372041	FITTING 8JIC/10SAE STRAIGHT 8-10 F50X
28	1	490199	FITTING STR 10-SAE/10-JIC
29	1	367145	FITTING STR 8-SAE/8-JIC
30	2	21502	WASHER SP/LK 1/2 HI COLLAR
31	2	21601	WASHER FL 1/2
32	2	12197	SOC HD 1/2-13
33	1	370433	CORD CONNECTOR HUBBLE F-3
34	1	812309-024	HOSE ASSY 8 STR/90
35	1	812409-022	HOSE ASSY 10 STR/90
36	1	480024	MOUNT PENDANT CABLE RETAINER
37	1	20601	WASHER 5/16 LOCK
38	1	7401	SCW 5/16-18 X 1/2 LG
39	1	480857000	BASE PLATE WELD
40	2	490198	FITTING 10SAE(M)/6JIC ELBOW 90
41	1	366359	FITTING 8 SAE/JIC SWIVEL PS810503-8-8
42	1	366358	FITTING 10SAE/JIC SWIVEL PS810503-10-10
43	48	374086	NYLON HOSE SLEEVE
44	1	480011	SEAL ROTATION BOX
45	1	366419	SWITCH, LIMIT ROTATION
46	1	480856000	LIMIT SWITCH ARM
47	2	642908	CORD CONNECTOR

***PEDESTAL ASSEMBLY  
8406H HARD WIRED SERIES***

ITEM NO.	QTY.	PART NO.	DESCRIPTION
48	2	20000	10 SAE FLAT WASHER
49	2	19800	10 SPLIT LOCK
50	2	330679	SCW BT HD SOCKET 10-32 X 1/2
51	2	11202	SCW HX HD 1/2-20 X 2 3/4
52	2	17704	NUT HX HVY 1/2 NF
53	1	360162	RING, ECCENTRIC
54	1	360207	RETAINER ECCENTRIC RING
55	1	20600	WASHER SP LK 5/16 NC
56	1	7807	SCW HEX 5/16-18 3/4LG GR5
57	1	480865000	BRACKET BOOM SWITCH
58	1	654100	SWITCH LIMIT BZ-2RW80-A2
59	2	602	SCW PN #6 NC X 1
60	2	15400	NUT HX #6-32
61	1	480880000	LOAD SENSOR SWITCH, 2500 PSI
62	1	366473000	MAIN HARNESS ASSEMBLY, HARD WIRED
63	1	366522001	HOUSING, PLUG, DEUTSCH 12-PIN
64	1	366522002	WEDGE, DEUTSCH PLUG, 12 SOCKET
65	1	366363001	AMP MODIFICATION, CONNECTORS

# MAIN WIRING HARNESS

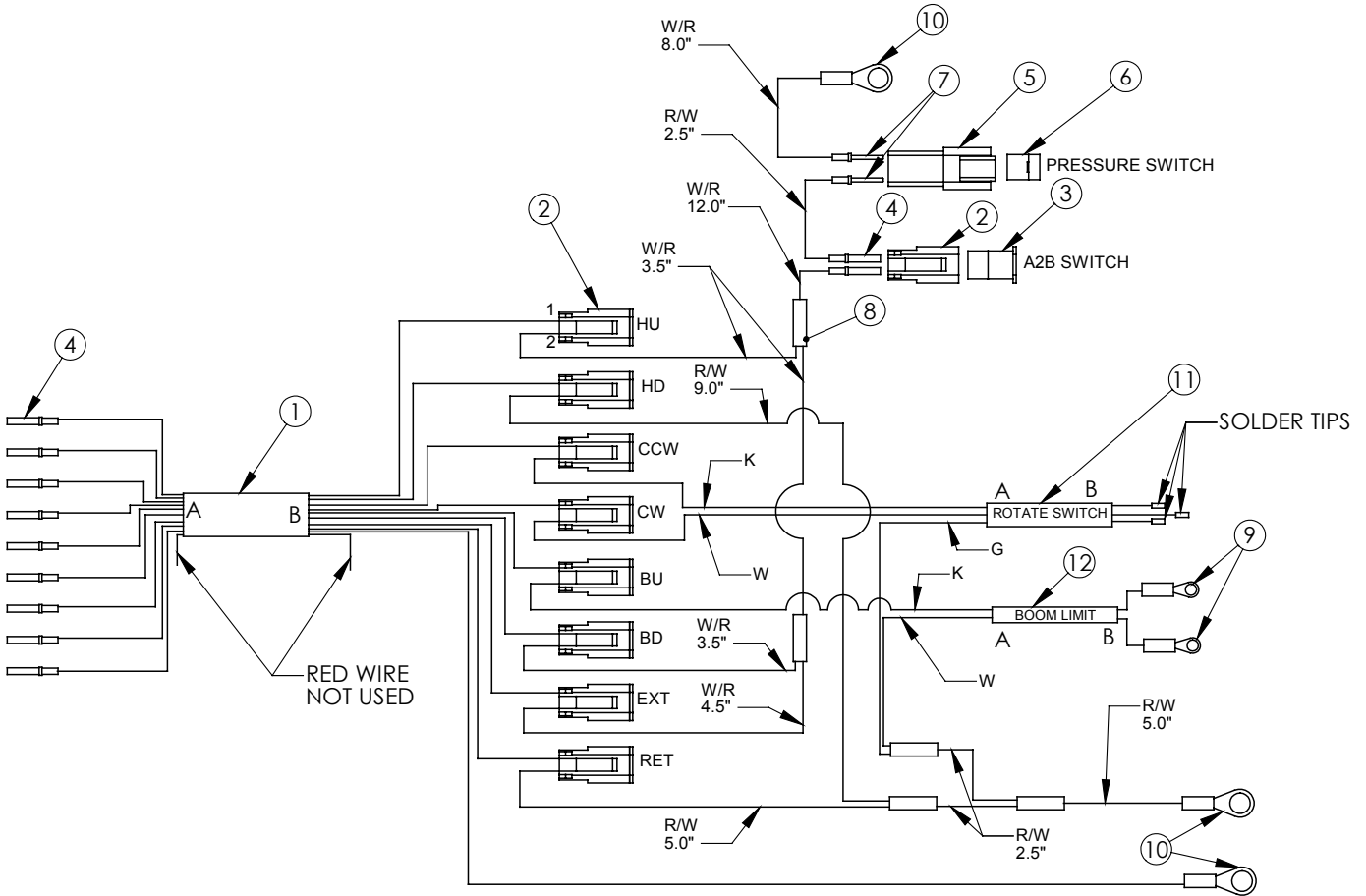

FUNCTION	PIN	WIRE COLOR	NOTES
HOIST UP	1	GREEN	POWER
	2	WHITE/RED	TO A2B GROUND
HOIST DN	1	RED/BLACK	POWER
	2	RED/WHITE	GROUND
ROTATE CCW	1	WHITE/BLACK	POWER
	2	WHITE	TO CCW SWITCH (3 COND CABLE)
ROTATE CW	1	ORANGE	POWER
	2	BLACK	TO CW SWITCH (3 COND CABLE)
BOOM UP	1	WHITE	POWER
	2	BLACK	BOOM SWITCH CABLE
BOOM DN	1	BLUE	POWER
	2	WHITE/RED	TO A2B GROUND
EXTEND	1	GREEN/BLACK	POWER
	2	WHITE/RED	TO A2B GROUND
RETRACT	1	ORANGE/BLACK	POWER
	2	RED/WHITE	GROUND
A2B SWITCH	1	WHITE/RED	TO PIN 1, PRESSURE SWITCH
	2	RED/WHITE	FROM HU, BD, EXT GND
PRESSURE SWITCH	1	RED/WHITE	GROUND
	2	WHITE/RED	FROM A2B PIN 2
ROTATE SWITCH 3 COND CABLE	*	WHITE	*PIN 2 ON ROTATE CCW PLUG
	**	BLACK	**PIN 2 ON ROTATE CW PLUG
	NA	GREEN	GROUND
BOOM LIMIT 2 COND CABLE	***	WHITE	***PIN 2 ON BOOM UP PLUG
	NA	BLACK	

ITEM NO.	QTY.	PART NO.	DESCRIPTION
1	1	800632000	CABLE, 16/10 SO BLACK
2	9	366367001	HOUSING, DEUTSCH 2-PIN PLUG
3	9	366367002	WEDGE, DEUTSCH PLUG, 2 PIN
4	27	366367003	CONTACT, DEUTSCH SOCKET
5	1	360769001	HOUSING, DEUTSCH 2-PIN RECEPTACLE
6	1	360769002	WEDGE, DEUTSCH 2-PIN RECEPTACLE
7	2	366376003	CONTACT, DEUTSCH
8	5	001104000	TERMINAL SPLICE 14-16 GA
9	2	000101000	TERMINAL RING, 5/32, 14-16 GA
10	3	000501000	TERMINAL RING, 5/16, 14-16 GA
11	1	800628000	WIRE, 3 CONDUCTOR
12	1	800626000	WIRE, 2 CONDUCTOR
13	31'	800618000	WIRE, 16GA, WHITE/RED
14	26'	800617000	WIRE, 16GA, RED/WHITE

# JUNCTION BOX ASSEMBLY HARD WIRED SERIES

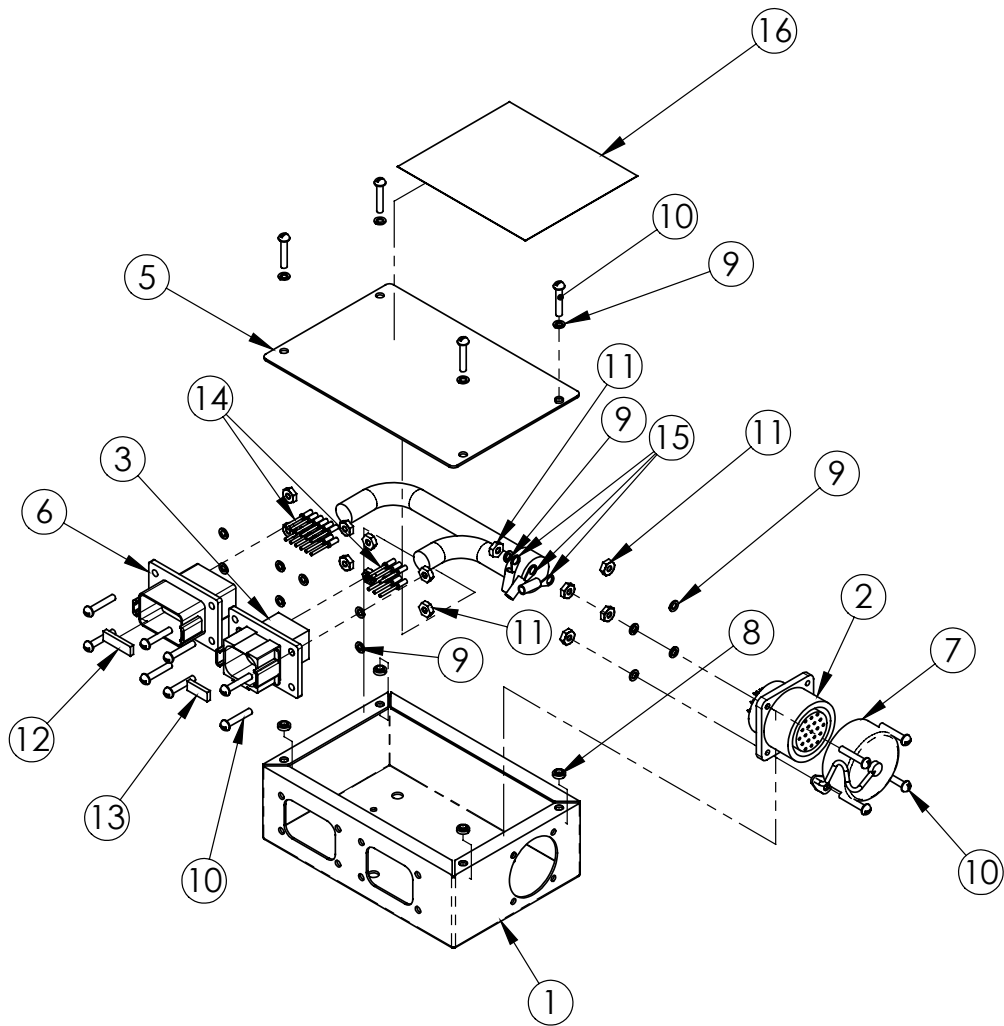

FUNCTION	19 PIN	8 PIN	12 PIN	GND	WIRE COLOR
BOOM UP	A		5		RED
HOIST UP	B		1		GREEN
ROTATE CW	C		4		ORANGE
ENGINE FAST	D	3			RED/WHITE
ROTATE CCW	E		3		BLACK
HOIST DN	F		2		RED/BLACK
BOOM DN	G		6		BLUE
RETRACT	H		8		ORANGE/BLACK
EXTEND	J		7		GREEN/BLACK
NOT USED	K	-	-		WHITE/BLACK
POWER	L	1			WHITE
PROP +0 TO 5V	M		11		BLUE/BLACK
GROUND	N			GND	BLACK/WHITE
AUXILARY	P	4			GREEN/WHITE
ENGINE START	R	5			BLUE/WHITE
ENGINE STOP	S	6			BLACK/RED
PROP POWER	T		9		WHITE/RED
NOT USED	U	-	-		ORANGE/RED
NOT USED	V	-	-		BLUE/RED
GROUND			10	GND	BLACK/WHITE
GROUND		2		GND	BLACK/WHITE
GROUND			12	GND	BLACK/WHITE



***JUNCTION BOX ASSEMBLY  
HARD WIRED SERIES***

ITEM NO.	QTY.	PART NO.	DESCRIPTION
1	1	366470000	JUNCTION BOX
2	1	366095	RECEPTACLE, 19 PIN
3	1	366523001	HOUSING, DEUTSCH 8-PIN RECEPTACLE
4	1	480594001	CABLE, PENDANT, 16/10 SO BLACK
5	1	366471000	COVER, JUNCTION BOX
6	1	366524001	HOUSING, DEUTSCH 12-PIN RECEPTACLE
7	1	366097000	CAP W/CHAIN (FOR RECEPTACLE)
8	4	366519000	NUT, SELF CLINCHING
9	17	019600	WASHER SP LK #6
10	16	001004000	SCW PN HD #6 X 3/4 LG
11	13	015400	NUT HX #6-32
12	1	366524002	WEDGE, DEUTSCH RECEPTACLE, 12 PIN
13	1	366523002	WEDGE, DEUTSCH RECEPTACLE, 8 PIN
14	18	366376003	CONTACT, DEUTSCH
15	3	000101000	TERMINAL RING, 5/32, 14-16 GA
16	1	366469000	DECAL, JUNCTION BOX WIRING

# PENDANT ASSEMBLY, 8 FUNCTION HARD WIRED SERIES

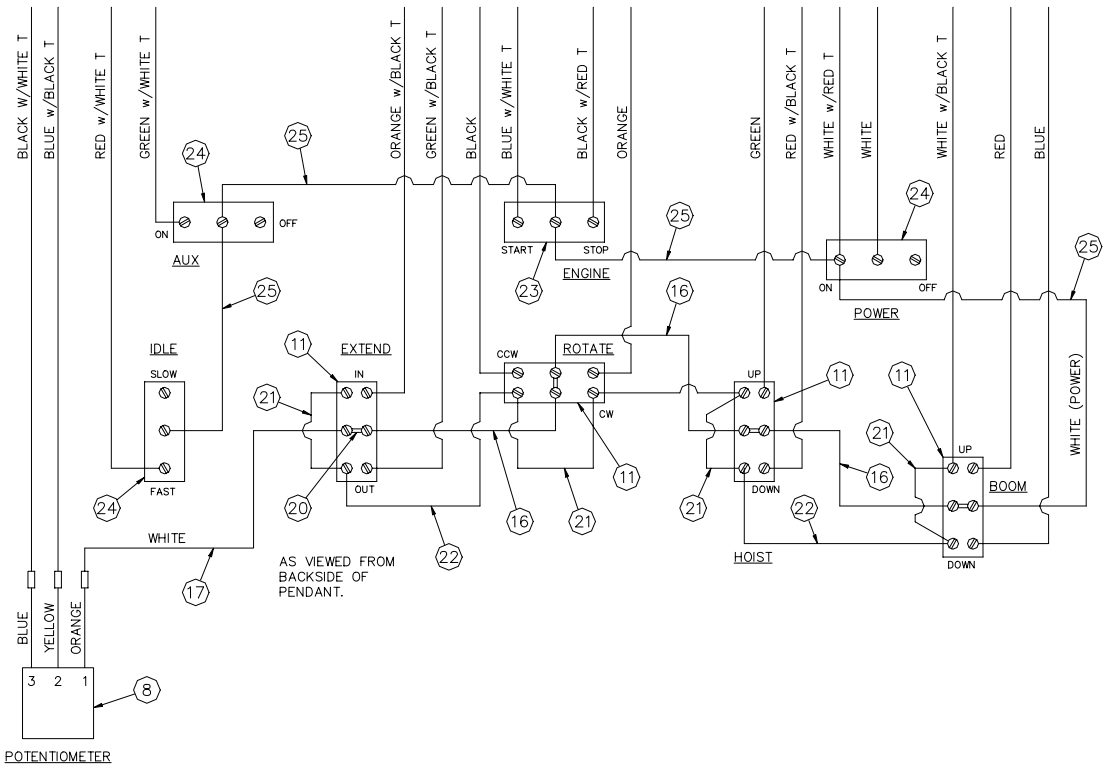
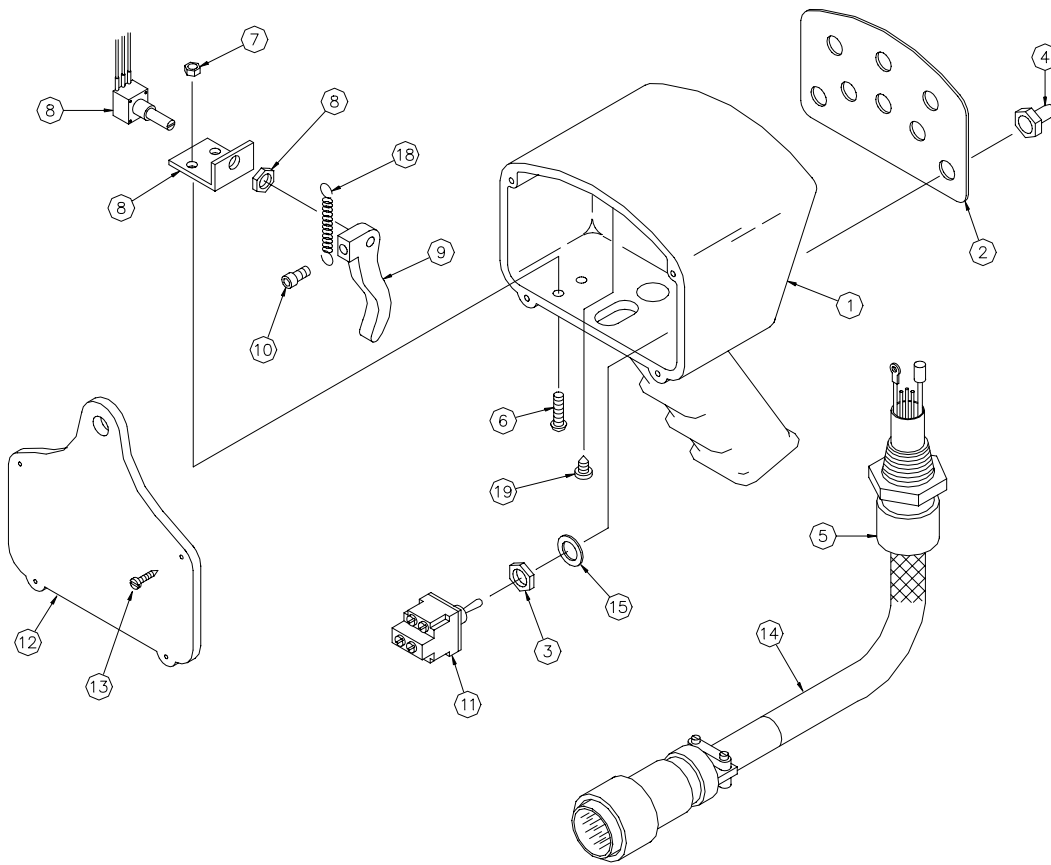

***PENDANT ASSEMBLY, 8 FUNCTION  
HARD WIRED SERIES***

ITEM	QTY	PART NO.	DESCRIPTION
1	1	480501	HOUSING, PROP. PENDANT MACHINED
2	1	480518	DECAL/COVER PLATE
3	8	REF	NUT (INCLUDED WITH SWITCH)
4	8	640300	BOOT, TOGGLE
5	1	480567	CORD GRIP, HUBBELL CONNECTOR
6	2	002607	SCREW, HX HD #10-24 NC X 3/4 LG
7	2	015801	NUT, HEX, LOCKING, #10-24 NC
8	1	480507	POTENTIOMETER ASSEMBLY
9	1	480506	TRIGGER
10	1	480517	SCREW, SOC HD, #10-32 NF X 5/8 LG
11	4	634200	SWITCH, TOGGLE DPDT
12	1	480504	BACK PLATE, HOUSING
13	4	001004	SCREW, PAN HD, #6-32 X 3/4 LG
14	1	680113	CABLE ASSEMBLY, BAYONET
15	8	REF	WASHER, LOCK (INCLUDED WITH SWITCH)
16	3	660302	CONDUCTOR ASSEMBLY
17	1	480524	CONDUCTOR ASSEMBLY
18	1	480523	SPRING, TRIGGER RETURN
19	1	005003	SCREW, S.T. PAN HD, #6-32 X 3/8 LG
20	4	636600	JUMPER
21	4	622346	CONDUCTOR ASSEMBLY
22	3	622347	CONDUCTOR ASSEMBLY
23	1	622000	SWITCH, TOGGLE SPDT
24	3	750090	SWITCH, TOGGLE ON/OFF
25	1	480526	CONDUCTOR ASSEMBLY
26	2	750737	TIE, CABLE

# PENDANT CABLE ASSEMBLY HARD WIRED SERIES

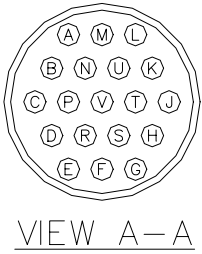
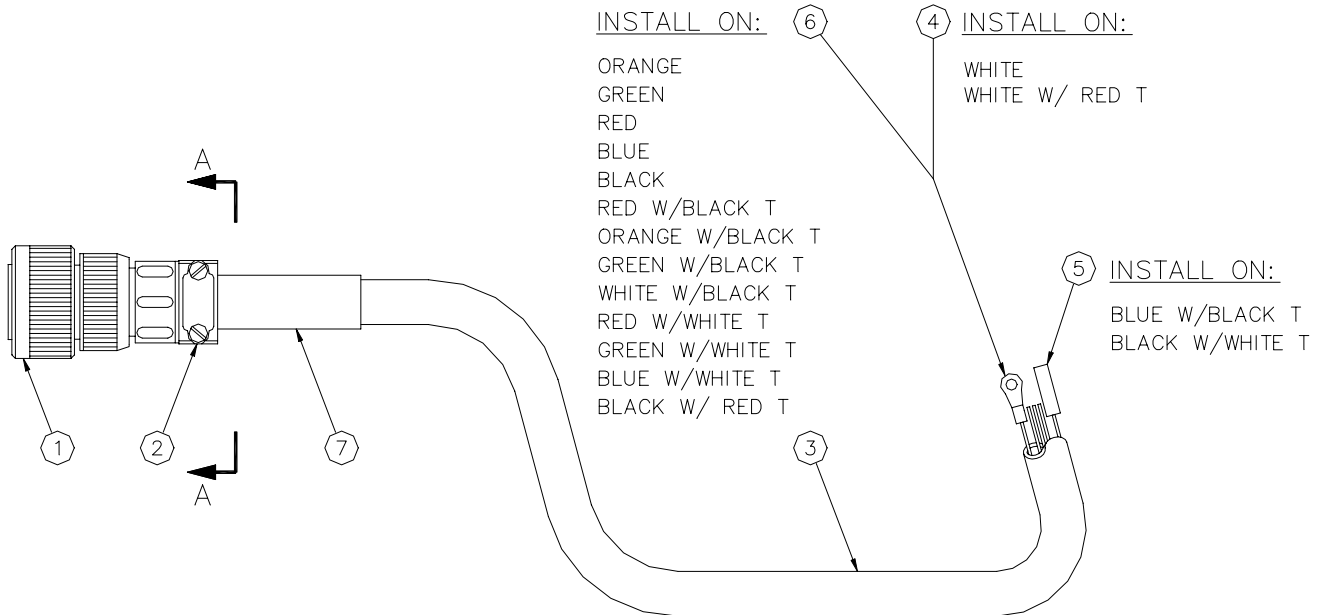

### WIRING GUIDE

- |                    |                   |
|--------------------|-------------------|
| A-RED              | L-WHITE           |
| B-GREEN            | M-BLUE W/BLACK T  |
| C-ORANGE           | N-BLACK W/WHITE T |
| D-RED W/WHITE T    | P-GREEN W/WHITE T |
| E-BLACK            | R-BLUE W/WHITE T  |
| F-RED W/BLACK T    | S-BLACK W/RED T   |
| G-BLUE             | T-WHITE W/RED T   |
| H-ORANGE W/BLACK T | U-ORANGE W/RED T  |
| J-GREEN W/BLACK T  | V-BLUE W/RED T    |
| K-WHITE W/BLACK T  |                   |

ITEM	QTY	PART NO.	DESCRIPTION
1	1	366098	PLUG, CONNECTOR
2	1	480515	CLAMP, CABLE
3	30'	480594	CABLE, CONDUCTOR (19 COND)
4	2	000101	TERMINAL RING #6 / 14-16 GA
5	2	480510	CONNECTOR, BULLET, FEMALE
6	13	002012	TERMINAL RING #6 / 18-22 GA
7	6"	490243	TUBING, HEAT SHRINK

# ***PROPORTIONAL VALVE CONTROLLER/AMP HARD WIRED SERIES***

REFERENCE AUTO CRANE P/N 366363001

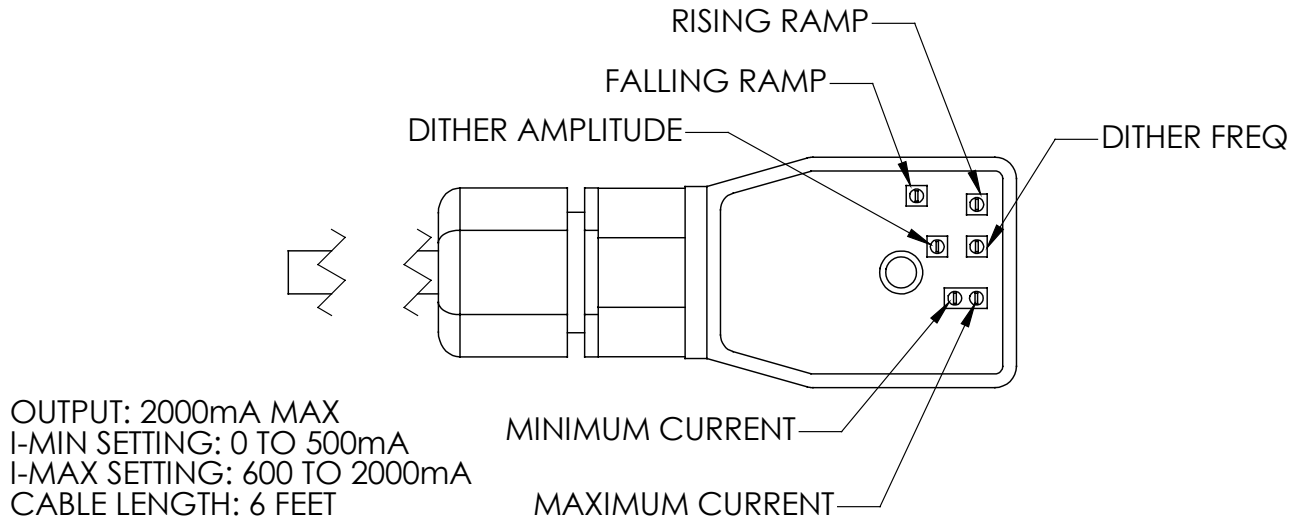

### Minimum current adjustment:

Current is factory set at 150 mA, no adjustment required at installation. If adjustment is required, set the minimum current before setting the maximum current. Apply minimum input (0 VDC). If the desired minimum current is greater, adjust the trim pot CW until the desired current is achieved.

### Maximum current:

Current is factory set at 1600 mA, no adjustment required at installation. If adjustment is required, apply maximum control (5 VDC). Turn the trim pot CCW to adjust the current setting downwards to the desired minimum.

### Ramp and Dither

Ramp and dither is adjusted at the factory and does not require any further adjustment.



P.O. Box 580697 \* Tulsa, OK 74158-0697  
4707 N. Mingo Rd. \* Phone (918) 836-0463

## LIMITED WARRANTY 2 YEAR PARTS AND LABOR

Auto Crane will warranty to the consumer for a period of (2) years parts and labor from the date of purchase. Each new Auto Crane unit they sell will be free under normal use and service from defects in material and workmanship. Date of purchase will be honored as the date indicated on the Bill of Sale, which must accompany the Warranty Registration and be on file with Auto Crane. Absent a valid Warranty Registration and appropriate documentation, the original date of manufacture, as indicated by the serial number on the product, will be used to determine the effective date of the 2 year warranty.

The obligation of Auto Crane under this warranty is limited to the replacement or repair of parts that appear to the manufacturer after review and/or inspection to be defective and paid flat rate labor for replacing defective parts. This warranty does not obligate Auto Crane to bear the travel time charges in connection with the replacement or repair of defective parts. Responsibility for customer's claims arising from misapplication, abuse, misuse or alteration of equipment or parts lies with the distributor or user and no warranty obligation is assumed in these circumstances by Auto Crane.

Auto Crane will in no event be liable for any consequential damages or contingent liabilities arising out of the failure of any Auto Crane Product or parts to operate properly.

Auto Crane makes no warranty in respect to component accessories, it being subject to the warranties of their respective manufacturers.

If field service, at the request of the distributor, is rendered and fault is found not to be with Auto Crane's product, the distributor shall pay the time and expense of the field representative.

Claims for service labor or other expenses that have incurred by the buyer without approval or authorization or Auto Crane will not be accepted.

When applying for warranty, claims may be handled by contacting your nearest authorized Auto Crane Distributor. All claims are to be filed in writing on an Auto Crane Warranty Claim Form.

**AUTO CRANE COMPANY IS UNDER NO OLIGATION TO EXTEND THIS WARRANTY TO ANY CUSTOMER FOR WHICH AN AUTO CRANE DELIVERY REPORT FORM HAS NOT BEEN COMPLETED AND ON FILE WITH AUTO CRANE COMPANY**