

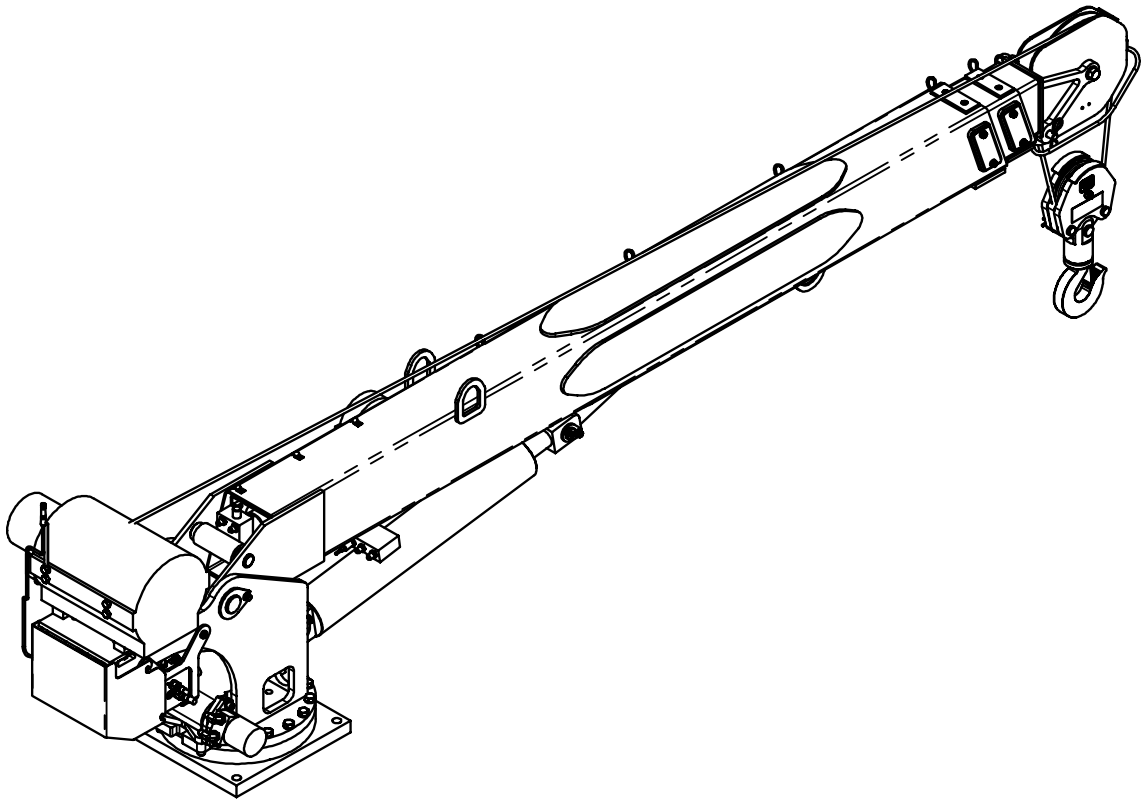

6406H OWNERS MANUAL

Manual No. 366900000
Rev. 09/8/05



Serial No. _____

Mailing Address:
P.O. Box 580697
Tulsa, OK 74158-0697
Physical Address:
4707 N. Mingo Rd.
Tulsa, OK 74117-5904

Phone (918) 836-0463
Fax (918) 834-5979
<http://www.autocrane.com>



Auto Crane Warranty Registration

Fax Transmission

To: Warranty Department Fax: (918) 834-5979
 From: _____ Date: _____
 Re: Product Registration Pages: _____

End User Information: (Required for Warranty Activation)

Name: _____ Phone: _____
 Address: _____
 City: _____ State: _____ Zip: _____
 Contact: _____ E-mail Address: _____

Distributor Information: (Required for Warranty Activation)

Name: _____
 Address: _____
 City: _____ State: _____ Zip: _____
 Contact: _____ E-mail Address: _____

Product Information: (Required for Warranty Activation)

Model No.: _____ Serial No.: _____
 Date Product Delivered: _____ Date Processed:* _____
 VIN # _____ * For Auto Crane use only

ONE REGISTRATION FORM PER UNIT (CRANE OR BODY)

Registration form must be mailed or faxed within 15 days of customer installation.

Mail to:
 Warranty Department
 Auto Crane Company
 P.O. Box 581510
 Tulsa, OK 74158-0697

6406H

OWNER'S MANUAL REVISION RECORD

Revision Date	Section(s) Or Page(s)	Description of Change
09/02/03	Last page	New 2-year warranty policy to replace 1-year warranty policy
09/15/03	10-5 and 10-9	Wiring schematic corrections for rotation stop switch
12/30/03	Mounting & Instl. (p. 3-2.0.0) Lub. & Maintenance (p.4-1.0.0)	Revised torque specs for mounting hardware for crane, rotation bearing and rotation gear box.
4/23/04	Pages 3-2, 5-2 & 8-9	Updated receiver & transmitter to 2 nd generation
07/26/04	Pages 10-1.0.0, 10-3.0.0, 10-5.0.0, 10-6.0.0, 10-9.0.0 & 10.-10.0.0	Added voltage drop relay circuit
07/27/05	All	General revision, Added unloader valve, Changed to Gen 2 FM controller

WARNINGS

WARNING! Federal law (49 cfr part 571) requires that the Final Stage Manufacturer of a vehicle certify that the vehicle complies with all applicable federal regulations. Any modifications performed on the vehicle prior to the final state are also considered intermediate stage manufacturing and must be certified as to compliance. The installer of this crane and body is considered one of the manufacturers of the vehicle. As such a manufacturer, the installer is responsible for compliance with all applicable federal and state regulations, and is required to certify that the vehicle is in compliance.

WARNING! It is the further responsibility of the installer to comply with the OSHA Truck Crane Stability Requirements as specified by 29 CFR part 1910.180 (C) (1).

WARNING! NEVER OPERATE THE CRANE NEAR ELECTRICAL POWER LINES!

Death or serious injury will result from boom, line, or load contacting electric lines. Do not use crane within 10 feet (3.05m) of electric power lines carrying up to 50,000 volts. One-foot additional clearance is required for every additional 30,000 volts or less. **SEE DANGER DECAL (P/N 040529)** in this Owner's Manual.

WARNING! NEVER.....

- ◆ **EXCEED** load chart capacities (centerline of rotation to hoist hook).
- ◆ Un-reel last 5 wraps of cable from drum!
- ◆ Wrap cable around load!
- ◆ Attempt to lift or drag a load from the side! The boom can fail far below its rated capacity.
- ◆ Weld, modify, or use unauthorized components on any Auto Crane unit! This will void any warranty or liability. Also failure of the crane may result.
- ◆ Place a chain link on the tip of the hook and try to lift a load!
- ◆ Use a sling bar or anything larger than the hook throat that could prevent the hook latch from closing, thus negating the safety feature!
- ◆ Hold on any pendant Select Switch that will cause unsafe operating conditions!

WARNING! In using a hook with latch, **ALWAYS** make sure that the hook throat is closed before lifting a load! Proper attention and common sense applied to the use of the hoist hook and various slings will prevent possible damage to material being hoisted and may prevent injury to personnel.

WARNING! Failure to correctly plumb and wire crane can cause inadvertent operation and damage to crane and/or personnel!

WARNING! Auto Crane Company remote controlled cranes are not designed or intended for use for any applications involving the lifting or moving of personnel.

WARNING! ALWAYS operate the crane in compliance with the load capacity chart. **DO NOT USE** the overload shutdown device to determine maximum rated loads, if the crane is equipped with this type of device.

READ THIS PAGE

6406H

TABLE OF CONTENTS

INTRODUCTION	1-1.0
GENERAL SPECIFICATIONS	1-3.0
SAFETY TIPS AND PRECAUTIONS	2-1.0
OPERATING PRACTICES & WARNINGS	2-3.0
QUALIFICATIONS FOR OPERATORS	2-4.0
OPERATION OF UNIT / OUTRIGGERS	2-7.0
CONTROLLER OPERATIONS	2-8.0
INSPECTION	3-1.0
TESTING	3-4.0
MAINTENANCE	3-5.0
BATTERIES	3-7.0
LUBRICATION AND MAINTENANCE SCHEDULE	3-9.0
SAFETY DECAL SECTION	4-1.0
GENERAL DIMENSIONS	5-1.0
MOUNTING AND INSTALLATION	5-2.0
GENERAL ASSEMBLY, HARDWIRED	6-1.0
PEDESTAL ASSEMBLY, HARDWIRED	6-3.0
BOOM ASSEMBLY	6-7.0
ROTATION GEARBOX	6-9.0
HOIST ASSEMBLY	6-11.0
TRAVELING BLOCK ASSEMBLY	6-14.0
ELECTRICAL SECTION, HARDWIRED	7-1.0
MAIN WIRING HARNESS	7-2.0
JUNCTION BOX	7-3.0
PENDANT ASSEMBLY	7-5.0
PENDANT CONTROL ASSEMBLY	7-7.0
PROPORTIONAL VALVE	7-8.0
HYDRAULIC SECTION, HARDWIRED	8-1.0
GENERAL ASSEMBLY, FM	9-1.0
PEDESTAL ASSEMBLY, FM	9-3.0
ELECTRICAL SECTION, FM	10-1.0
HYDRAULIC SECTION, FM	11-1.0
DIAGNOSTICS	12-1.0
LOAD CHART	13-1.0
WARRANTY	LAST PAGE

6406H INTRODUCTION

Auto Crane products are designed to provide many years of safe, trouble-free, dependable service when properly used and maintained.

To assist you in obtaining the best service from your crane and to avoid untimely crane and/or vehicle failure, this manual provides the following operating and service instructions. It is specifically recommended that all operating and service personnel consider this manual as mandatory material for reading and study before operating or servicing Auto Crane products. It is highly recommended that crane owners, equipment managers, and supervisors also read this manual.

Auto Crane has incorporated several safety features in the 6406H crane for your protection.

For your convenience the overall dimensions of the 6406H crane are included on the General Dimension Drawing. Rotation and turning radius are also listed on that drawing.

Remember, the crane adds weight to the vehicle. Adding weight may change the driving and riding characteristics of the vehicle unless the appropriate overload spring(s) are installed on the truck. The payload of the vehicle is reduced by the weight of the crane. The operator should exercise care when loading the vehicle. Distributing the payload on the vehicle evenly will greatly improve the driving and riding characteristics of the vehicle.

Auto Crane Company issues a limited warranty certificate with each unit sold. See last page for warranty.

The 6406H cranes are attached to your 12-volt truck electrical system through the relay provided. The 6406H is another highly efficient Auto Crane product. The use of a maintenance-free battery is not recommended on any Auto Crane product. The recommended alternator and battery that will give the longest life with the most useful duty cycle is a 60-amp

alternator with a 500 cold cranking amp battery. These specifications should be considered minimum.

It has always been Auto Crane Company policy to handle all warranty claims we receive as promptly as possible. If a warranty claim involves discrepant material or workmanship, Auto Crane will take immediate corrective action. It is understandable that Auto Crane Company cannot assume responsibility of liability when it is obvious that our products have been abused, misused, overloaded or otherwise damaged by inexperienced persons trying to operate the equipment without reading the manual.

Auto Crane will not assume responsibility or liability for any modifications or changes made to unit, or installation of component parts without authorization.

Auto Crane maintains a strong distributor network and a knowledgeable Customer Service Department. In most cases, an equipment problem is solved via phone conversation with our customer service department. The customer service department also has the ability to bring a local distributor, a regional sales manager, or a factory serviceman into the solution of an equipment problem.

If, through no fault of Auto Crane Company, it is necessary to send an experienced factory serviceman on a field service call the rates stated in the Auto Crane Distributor's Flat Rate Manual will apply.

Auto Crane Company's extensive Research and Development Program allow our customers to use the best equipment on the market. Our Engineering Staff and our knowledgeable sales people are always available to our customers in solving crane and winch-type application problems. When in doubt, call the Auto Crane factory.

Note: This manual should remain with the crane at all times.

6406H INTRODUCTION

DISTRIBUTOR ASSISTANCE:

Should you require any assistance not given in this manual, we recommend that you consult your nearest Auto Crane Distributor. Our distributors sell authorized parts and have service departments that can solve almost any needed repair. This manual does not cover all maintenance, operating, or repair instructions pertinent to all possible situations. **If you require additional information, please contact the Auto Crane Company at the following telephone number: (918) 836-0463.** The information contained in the manual is in effect at the time of this printing. Auto Crane Company reserves the right to update this material without notice or obligation.

6406H

GENERAL SPECIFICATIONS

DIMENSIONS

Width: 23.25 in (0.59 m)
Height: 39.25 in (1.00 m)
Length: 13 ft 0-7/8 in (3.98 m)
 [Boom(s) stored]
Weight:
 1,725 lbs (782.4 kg)

CAPACITY

38,000 ft-lbs (5.20 ton-m)
 [ft-lbs = horizontal distance from centerline of rotation to free hanging weight (feet) x amount of weight (pounds)]

LIFTING CAPACITIES			
ft	lbs	ft	lbs
3	6,400	12	3,167
4	6,400	13	2,923
5	6,400	14	2,714
6	6,400	15	2,533
7	5,429	16	2,375
8	4,750	17	2,235
9	4,222	18	2,111
10	3,800	19	2,000
11	3,455	20	1,900

REACH

Second boom will reach from 10 feet 4 inches to 16 feet 4 inches.
 Third boom will reach from 16 feet 4 inches to 20 feet 4 inches.

CABLE

95 ft (28.9 m) of 3/8 in (9.5 mm) diameter aircraft quality cable. This cable has a single line breaking strength of 14,700 lbs (6,667.8 kg).

CHASSIS REQUIREMENTS

14,500 lbs (6,577 kg) GVWR minimum
 360,000 in-lbs RBM

ELECTRICAL SYSTEM REQUIREMENTS

Voltage: 12 VDC
Alternator: 60 amps (minimum)
Battery: 100 minute reserve capacity (minimum)
 Maintenance type

ROTATION

370° Rotation with electric stop.

--- IMPORTANT ---

SAFETY TIPS AND PRECAUTIONS

1. No unqualified or unauthorized person shall be allowed to operate the crane.
2. **WARNING:** Never weld, modify, or use unauthorized components / parts on any Auto Crane unit. This will void any warranty or liability. Also, failure of the crane may result.
3. Make certain the vehicle meets minimum chassis requirements. (These requirements do not guarantee unit stability.)
4. Make certain the crane is installed per factory specifications. Contact your local distributor or the Auto Crane factory if any questions arise.
5. Visual inspections and tests should be conducted at the beginning of each shift each day to insure that the crane and all its operating systems are in good condition and working order before it is used.
6. Inspect hydraulic hoses frequently for signs of deterioration, and replace them as required.
7. If a hydraulic break occurs, leave the area of the break and do not attempt to stop the break by hand as the hydraulic oil may be hot and under high pressure which can cause serious injury. Shut the system down as soon as possible.
8. Check the hook at least every thirty days for distortions or cracks and replace it as required.
9. Oil gears as required.
10. Stop all operations when cleaning, adjusting or lubricating the machine.
11. Keep dirt and grit out of moving parts by keeping crane clean. Make sure machine is free of excess oil, grease, mud and rubbish, thus reducing accidents and fire hazards.
12. When a new cable is installed, operate first with a light load to let the cable adjust itself.
13. Locate the vehicle at the work site for the best stability possible.
14. Keep the vehicle in a level position while loading or unloading.
15. Observe operating area for obstructions and/or power lines that might be a hazard.
16. **WARNING: NEVER OPERATE THE CRANE NEAR ELECTRICAL POWER LINES.** Auto Crane Company recommends that the crane never be any closer to a power line (including telephone lines) than 10 feet at any point.
17. Allow the vehicle engine to warm up before operating crane.
18. Know the weight of your rigging and load to avoid overloading the crane.
19. Deduct the weight of the load handling equipment from the load rating to determine how much weight can be lifted.
20. All load ratings are based on crane capacity, NOT the vehicle stability. Remember in lifting a heavy load, the weight can create enough tipping moment to overturn the vehicle
21. Always comply with load chart capacities, (centerline of rotation to hook).
22. Secure all loads before lifting.
23. Always set the emergency brake before beginning operation.
24. Keep objects and personnel clear of crane path during operation.
25. Operate control levers slowly and smoothly in order to meter oil flow for safe operation.
26. Always extend the outriggers from vehicle to the ground before crane operation. Insure that they are firmly positioned on solid footings. Stand clear of outriggers while they are being extended.
27. If any outrigger, when extended, rests on a curb or other object that prevents it from extending to its maximum distance, shorten bearing or fulcrum point and reduce the maximum load accordingly.
28. When an outrigger will not reach the ground due to holes or grades, it shall be blocked up to provide level and firm support for the truck.
29. When working in soft earth, use wide pads under outrigger feet to prevent sinking.
30. Always store outriggers before transportation.

WARNING!

Auto Crane Company cranes are not designed or intended for use in lifting or moving persons. Any such use shall be considered to be improper and the seller shall not be responsible for any claims arising there from. This sale is made with the express understanding that there is no warranty that the goods shall be fit for the purpose of lifting or moving persons or other improper use and there is no implied warranty or responsibility for such purposes.

--- IMPORTANT ---

SAFETY TIPS AND PRECAUTIONS

31. Always store the crane in its stowed position for transportation.
32. Remember the overall height of the entire unit for garage door clearance or when moving under objects with low overhead clearance
33. Disengage power takeoff (PTO) before moving the vehicle.
34. Always walk around the vehicle before moving.
35. Never drive with a load suspended from crane.
36. Do not take your eyes off a moving load. Look in the direction you are moving.
37. Never swing a load over people.
38. Do not stop the load sharply in midair so that it swings like a pendulum. Meter the control levers to avoid this situation.
39. Crane boom length should be kept as short as possible for maximum lifting capacity and greater safety. Longer booms require additional care in accelerating and decelerating the swing motion, and thus slow down the working cycle and reduce productivity.
40. Keep the load directly and vertically under the boom point at all times. Crane booms are designed to handle vertical loads, not side lifts.
WARNING: Never attempt to lift, drag, tow or pull a load from the side. The boom can fail far below its rated capacity.
41. Do not push down on anything with boom extensions; similarly do not lift anything with boom extensions.
42. Do not lift personnel with any wire rope attachment or hook. There is no implied warranty or responsibility for such purposes.
43. **WARNING:** In using a safety hook, ALWAYS close the hook throat before lifting a load. Proper attention and common sense applied to the use of the hook and various slings will prevent possible damage to material being hoisted and may prevent injury to personnel.
44. **WARNING:** Never place a chain link on the tip of the hook and try to lift a load with the hoist.
45. **WARNING:** Never use a sling bar or anything larger than the hook throat which could prevent the safety latch from closing, thus negating the safety feature.
46. Do not wrap the wire rope around sharp objects when using winch.
47. **WARNING:** Never unreel last 5 wraps of cable from drum.

--- IMPORTANT ---

OPERATING PRACTICES AND WARNINGS

1. Make certain the vehicle meets minimum chassis requirements. (These requirements do not guarantee unit stability)
2. Make certain the crane is installed per factory specifications. Contact your local Distributor or the Auto Crane factory if any questions arise.
3. Keep the vehicle in as level a position as possible while loading or unloading.
4. **ALWAYS** set the vehicle emergency brake before beginning crane operations.
5. **ALWAYS** use outriggers from vehicle to the ground during crane operation. Make sure they are firmly positioned on solid footings.
6. All load ratings are based on crane capacity, **NOT** truck/crane stability.
7. Keep objects and personnel clear of crane path during operation.
8. Keep hoist cable pulled tight at all times.
9. **REMEMBER**, in lifting a heavy load, the weight can create enough tipping momentum to overturn the vehicle.
10. **ALWAYS** keep load as close to ground as possible.
11. Hydraulic hoses need to be inspected frequently for signs of deterioration, and be replaced as required.
12. The hoist hook is an important item that an operator should consider and use properly. It should be checked on a daily basis for distortion or cracks.
13. **ALWAYS** store outriggers before road travel.
14. **WARNING! NEVER OPERATE THE CRANE NEAR ELECTRICAL POWER LINES!** Death or serious injury will result from boom, line, or load contacting electric lines. Do not use crane within 10 feet (3.05m) of electric power lines carrying up to 50,000 volts. One foot additional clearance is required for every additional 30,000 volts or less.
15. **WARNING! NEVER EXCEED** load chart capacities (centerline of rotation to hoist hook).
16. **WARNING! NEVER** un-reel last 5 wraps of cable from drum!
17. **WARNING! NEVER** wrap cable around load!
18. **WARNING! NEVER** attempt to lift or drag a load from the side! The boom can fail far below its rated capacity.
19. **WARNING! NEVER** weld, modify, or use unauthorized components on any Auto Crane unit! This will void any warranty or liability. Also failure of the crane may result.
20. **WARNING! NEVER** place a chain link on the tip of the hook and try to lift a load!
21. **WARNING! NEVER** use a sling bar or anything larger than the hook throat that could prevent the hook latch from closing, thus negating the safety feature!
22. **WARNING!** In using a hook with latch, **ALWAYS** insure that the hook throat is closed before lifting a load! Proper attention and common sense applied to the use of the hoist hook and various slings will prevent possible damage to material being hoisted and may prevent injury to personnel.
WARNING! NEVER hold any Control Select Switch on that will cause unsafe operating conditions!

WARNING!

Auto Crane Company remote controlled, stiff boom cranes are not designed or intended to be used for any applications involving the lifting or moving of personnel.

QUALIFICATIONS FOR AND CONDUCT OF OPERATORS AND OPERATING PRACTICES

REFERENCE ASME B30.5a AND OSHA 1910.180 FOR COMPLETE QUALIFICATION REQUIREMENTS

OPERATORS

1. Crane operation shall be limited to personnel with the following minimum qualifications:
 - A. Designated persons.
 - B. Trainees under the direct supervision of a designated person.
 - C. Maintenance and test personnel (when it is necessary in the performance of their duties).
 - D. Inspectors (crane).
2. No one other than the personnel specified above shall enter the operating area of a crane with the exception of persons such as oilers, supervisors, and those specified persons authorized by supervisors whose duties require them to do so and then only in the performance of their duties and with the knowledge of the operator or other persons.

QUALIFICATIONS FOR OPERATORS

1. Operators shall be required by the employer to pass a practical operating examination. Qualifications shall be limited to the specific type of equipment for which examined.
2. Operators and operator trainees shall meet the following physical qualifications:
 - A. Vision of at least 20/30 Snellen in one eye and 20/50 in the other, with or without corrective lenses.
 - B. Ability to distinguish colors, regardless of position, if color differentiation is required for operation.
 - C. Adequate hearing with or without hearing aid for the specific operation.
3. Evidence of physical defects or emotional instability, which render a hazard to operator or others, which in the opinion of the examiner could interfere with the operator's performance, may be sufficient cause for disqualification. In such cases, specialized clinical or medical judgment and tests may be required.
4. Evidence that operator is subject to seizures or loss of physical control shall be sufficient reason for disqualification. Specialized medical

tests may be required to determine these conditions.

5. Operators and operator trainees should have normal depth perception, coordination, and no tendencies to dizziness or similar undesirable characteristics.
6. In addition to the above listed requirements, the operator shall:
 - A. Demonstrate the ability to comprehend and interpret all labels, operator's manuals, safety codes, and other information pertinent to correct crane operations.
 - B. Posses the knowledge of emergency procedures and implement it.
 - C. Demonstrate to the employer the ability to operate the specific type of equipment.
 - D. Be familiar with the applicable safety regulations.
 - E. Understand the operating procedures as outlined by the manufacturer.
 - F. Be thoroughly familiar with the crane and its control functions.
 - G. Understand the operating procedures as outlined by the manufacturer.

CONDUCT OF OPERATORS

1. The operator shall not engage in any practice, which will divert his attention while actually operating the crane.
2. Each operator shall be responsible for those operations under the operator's direct control. Whenever there is any doubt as to safety, the operator shall consult with the supervisor before handling the loads.
3. The operator should not leave a suspended load unattended unless specific precautions have been instituted and are in place.
4. If there is a warning sign on the switch or engine starting controls, the operator shall not close the switch or start the engine until the warning sign has been removed by the appointed person.
5. Before closing the switch or starting the engine, the operator shall see that all controls are in the "OFF"

QUALIFICATIONS FOR AND CONDUCT OF OPERATORS AND OPERATING PRACTICES

- or neutral position and all personnel are in the clear.
6. If power fails during operation, the operator shall:
 - A. Move power controls to the "OFF" or neutral position.
 - B. Land the suspended load and boom, if practical.
 7. The operator shall be familiar with the equipment and its proper care. If adjustments or repairs are necessary, the operator shall report the same promptly to the appointed person, and shall also notify the next operator.
 8. The operator at the start of each shift shall test all controls. If any controls do not operate properly, they shall be adjusted or repaired before operations are begun.
 9. Stabilizers shall be visible to the operator while extending or setting unless a signal person assists operator.
- C. Means are provided to hold the vehicle stationary while operating the crane.
 - D. Before starting to lift, the hook shall be positioned over the load in such a manner as to minimize swinging.
 - E. During lifting care shall be taken that:
 1. There is no sudden acceleration or deceleration of the moving load.
 2. Load, boom or other parts of the crane do not contact any obstruction.
 - F. Cranes shall not be used for dragging loads sideways.
 - G. This standard recognizes that telescopic boom cranes are designed and intended for handling materials. They do not meet personnel lift or elevator requirements. Therefore, no lifting, lowering, swinging or traveling shall be done while a person is on the hook or load. Hook attached suspended work platforms (baskets) shall not be used with cranes covered by this standard. Crane manufacturer must approve work platforms attached to the boom.
 - H. The operator should avoid carrying loads over people.
 - I. When the crane is so equipped, the stabilizers shall be fully extended and set. Blocking under stabilizers shall meet the requirements as follows:
 1. Strong enough to prevent crushing.
 2. Of such thickness, width and length as to completely support the stabilizer pad.
 - J. Firm footing under all tires, or individual stabilizer pads should be level. Where such a footing is not otherwise supplied, timbers, cribbing, or other structural members to distribute the load so as to not exceed allowable bearing capacity or the underlying material should provide it.
 - K. In transit, the boom shall be carried in stowed position.
 - L. When rotating the crane, sudden starts and stops shall be avoided. Rotational speed shall be such that the load does not swing out beyond the radius at which it can be controlled.
 - M. The crane shall not be transported with a load on the hook unless recommended by the manufacturer.

OPERATING PRACTICES/HANDLING THE LOAD

1. Size of load.
 - A. No crane shall be loaded beyond the rated load except for test purposes.
 - B. The load to be lifted is to be within the rated load of the crane and its existing configuration.
 - C. When loads that are not accurately known are to be lifted, the person responsible for the job shall ascertain that the weight of the load does not exceed the crane rated load at the radius at which the load is to be lifted.
2. Attaching the load.
 - A. The load shall be attached to the hook by means of slings or other devices of sufficient capacity.
 - B. Hoist rope shall not be wrapped around the load.
3. Moving the load.

The operator shall determine that:

 - A. The crane is level and, where necessary, the vehicle/carrier is blocked properly.
 - B. The load is well secured and balanced in the sling or lifting device before it is lifted more than a few inches.

QUALIFICATIONS FOR AND CONDUCT OF OPERATORS AND OPERATING PRACTICES

N. No person should be permitted to stand or pass under a suspended load.

4. Stowing procedure.

Follow the manufacturer's procedure and sequence when stowing and un-stowing the crane.

3. Caution shall be exercised when working near overhead lines, because they can move horizontally or vertically due to wind, moving the danger zone to new positions.

4. In transit with no load and boom lowered the clearance shall be specified in Table 1.

5. A qualified signalperson shall be assigned to observe the clearance and give warning before approaching the above limits.

MISCELLANEOUS

OPERATING NEAR ELECTRICAL POWER LINES

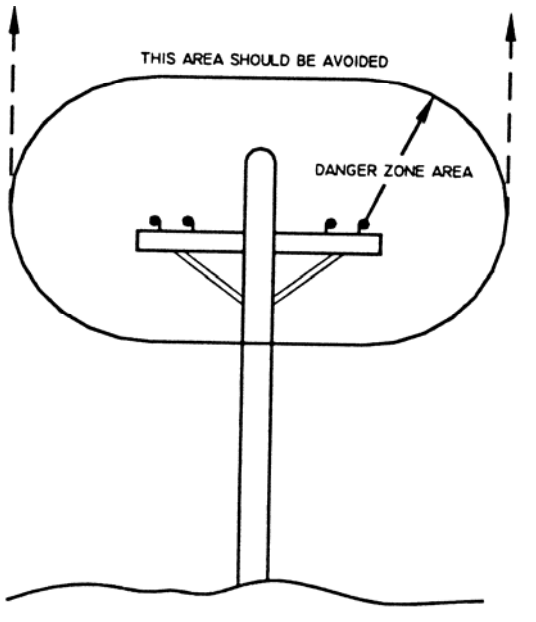

1. Cranes shall be operated so that no part of the crane or load enters into the danger zone shown above.

EXCEPTIONS

A. The danger zone may be entered after confirmation by an appointed person that the electrical distribution and transmission lines have been de-energized and visibly grounded at the point of work; or

B. The danger zone may be entered if insulating barriers (not a part of nor an attachment to the crane) have been erected to prevent physical contact with the lines.

2. For lines rated 50 kV or below, minimum clearance between the lines and any part of the crane or load (including handling appendages) shall be 10-ft. (3m). For higher voltages, see Table 1.

A. Any overhead wire shall be considered to be an energized line unless and until the person owning such line or the electrical utility authorities verify that it is not an energized line.

B. Exceptions to this procedure are allowed, if approved by the administrative or regulatory authority provided the alternate procedure insures equivalent protection and is set forth in writing.

C. Durable signs shall be installed at the operator's station and on the outside of the crane, warning that electrocution or serious bodily injury may occur unless a minimum clearance of 10 ft. (3.0m) between the crane or the load being handled and energized power lines. Greater clearances are required because of higher voltage as stated above. These signs shall be revised but not removed when local jurisdiction requires greater clearances.

TABLE 1

		minimum required clearance	
normal voltage, kV (phase to phase)		ft	(m)
<u>when operating near high voltage power lines</u>			
over	to 50	10	(3.50)
over	50 to 200	15	(4.6)
over	200 to 350	20	(6.1)
over	350 to 500	25	(7.62)
over	500 to 750	35	(10.67)
over	750 to 1000	45	(13.72)
<u>while in transit with no load and boom lowered</u>			
over	to 0.75	4	(1.22)
over	0.75 to 50	6	(1.83)
over	50 to 345	10	(3.83)
over	345 to 750	16	(4.87)
over	750 to 1000	20	(6.1)

--- IMPORTANT --- OPERATION OF UNIT

1. Make sure this manual has been thoroughly read by all crane operating personnel and supervisors.
2. A routine inspection of the crane should be mandatory before each operating day. Any defects should be corrected immediately.
3. At a job site the vehicle should be positioned so that the crane can adequately reach the load within the rated capacity (centerline of rotation to hoist hook).
4. Keep the vehicle as level as possible during operation.
5. For electric cranes, **engage emergency brake** and leave ignition on with transmission in neutral (or in park for automatic transmissions). Activate any crane power switches. For Auto Crane units requiring battery and hydraulic operation, **engage emergency brake**, place gear selector in neutral, press clutch, activate PTO, release clutch and after hydraulic fluid is warm, set throttle control to proper engine speed.
6. Always use outriggers from the truck to the ground. Be sure these are firm and adequately positioned. When rotating, **keep load as low to the ground as possible**.
7. Remove the transmitter from cab or storage area. Power transmitter on. Detach hook from dead man. Crane is now ready for operation.
8. Always boom up before rotating so the boom will clear the required boom support.
9. When extending the boom, always maintain clearance between the boom crown and the traveling block or hoist hook.
10. Always observe safe and practical operation to avoid possible accidents. Refer to Safety Tips and Precautions.
11. After completing lifting operations, return the boom to stowed position on the boom support. Avoid unneeded pressure on the boom support.
12. Store transmitter in proper location (in cab or storage area).
13. Return outriggers to stowed position. Make sure they are pinned in place or jacklegs are returned to compartment.
14. Check work area for any tools or equipment not stored.
15. Release throttle control, depress clutch and disengage PTO. Deactivate any crane power switches.
16. Report any unusual occurrence during crane operation that may indicate required maintenance or repair.
17. **NEVER** use two cranes to support a load too large for either crane.

OPERATION OF OUTRIGGERS

HYDRAULIC OUTRIGGERS

1. Shift crane/outrigger control valve to "outrigger" position.
2. Operate the outrigger control valves to position the outriggers.
3. After outriggers are positioned, return crane/outrigger selector to "crane" position.
4. Crane is now ready to operate.

MANUAL OUTRIGGERS

1. Pull lock pins to release jackleg or drop down outrigger and move to outermost lock position.
2. Make sure lock pins are reinstalled properly.
3. Lower outrigger pad to firm ground and adjust foot to take out slack.
4. Crane is now ready to operate.

FM CONTROL SYSTEM OPERATION

TRANSMITTER LAYOUT

The red light to the left of the *Power On/Off* button indicates low transmitter battery. As the battery runs down, the light will begin to flash. It will flash increasingly faster as the battery power decreases (see "Charging the Transmitter").

The green light to the right of the *Power On/Off* button indicates that the unit is transmitting. This light will flash when a function is activated. The rate at which it flashes depends on the mode of transmission. When transmitting using the pendant cable, the green light will flash noticeably faster than when unplugged.

In addition to the two lights mentioned above there is four function toggle switches. These functions from left to right are to be used to raise and lower the boom, raise and lower the hoist cable, rotate the crane and extend and retract the boom. There are also buttons for auxiliary functions such as *Engine Start/Stop* and *Engine Fast Idle*.

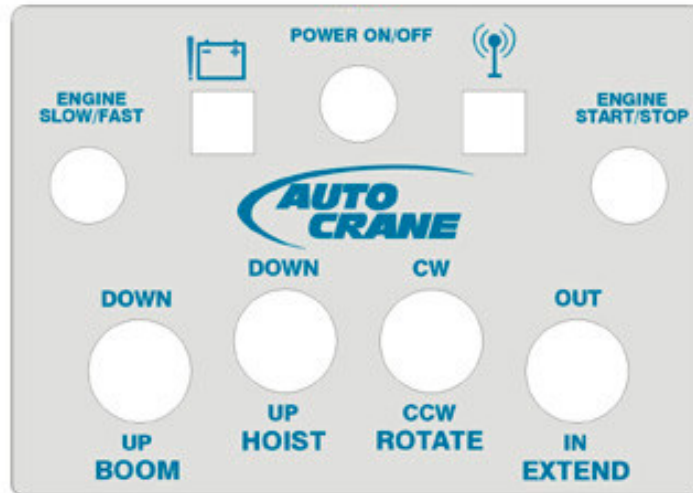

POWER ON/OFF BUTTON

To turn the transmitter on, press and hold the *Power On/Off* button, release once the transmit light becomes solid. To turn the unit off, press and hold the power button, release once the transmit light stops flashing. When this button is pressed both the red battery low and the green transmit light will flash alternately and stop flashing once the unit is either on or off.

FUNCTION SWITCHES

To operate a function, toggle one of the function switches with either the thumb of the hand holding the unit or the thumb or fingers of the opposite hand. Using the forefinger of the hand holding the unit, slowly pull the trigger back to start the function. The speed of the function increases as the trigger is pulled. More than one function can be activated at one time.

NOTE: A FUNCTION SWITCH MUST BE ACTIVATED BEFORE THE TRIGGER IS PULLED OR THE CRANE WILL NOT OPERATE.

FM CONTROL SYSTEM OPERATION

AUXILLARY BUTTONS

Functions described in this paragraph will not worked if not properly connected to the vehicle at the time of installation. Press the *Engine Slow/Fast* button to provide a maintained voltage to a throttle control. To stop the engine, press the *Engine Start/Stop* button. To start the engine, press the *Engine Start/Stop* button a second time within five (5) seconds of releasing it. To activate the auxiliary function, press the *Engine Slow/Fast* and the *Engine Start/Stop* buttons simultaneously.

SAFETY FEATURES

For safety reasons the speed of the rotation function is reduced when the lift cylinder pressure exceeds a set pressure. This will occur under load or under boom down operation. To limit slow operation of an unloaded crane, activate boom up momentarily after booming down to relieve cylinder pressure created by the counterbalance valve.

The crane is also equipped with an anti-bridging feature. The logic in the receiver will not allow the operator to rest the boom of the crane on a load supporting structure and lift a load. Doing so is dangerous and could damage the crane. When the crane is bridged, the receiver will display '*RSBM*' which requires the boom to be raised. This feature is disabled when the crane is in the '*HOME*' position to allow for stowing.

OPERATION FAILURE

If the crane does not operate as expected, observe the readout through the window on the receiver and refer to the front panel for explanation. The codes are further explained in the Diagnostics section of this manual. Please note that '*NRML*' is displayed when the crane is operating normally, '*HOME*' is displayed when the crane is forward and in a position to be stowed and '*SLOW*' is displayed when functions are slowed due to load. '*EC01*' will be displayed if no function is activated on the transmitter.

CHARGING THE TRANSMITTER

The transmitter can be charged using one of three methods. It can be charged with the cigarette lighter charger, the pendant cable or the optional *AC adapter (P/N 366505000)*. To charge the transmitter with the pendant cable, the crane must have electrical power. The crane can be operated by pendant or by FM remote, therefore the battery can be charged without suspending operation of the crane.

The transmitter should be fully charged after approximately 6 to 8 hours of charging. It is not recommended to leave the transmitter charging for extended periods of time (3 or 4 days). Doing so will eventually degrade the battery and it will not keep a good charge.

INSPECTION REQUIREMENTS

REFERENCE ASME B30.5a AND OSHA 1910.180 FOR COMPLETE INSPECTION REQUIREMENTS

INSPECTION CLASSIFICATION

1. Initial inspection.

Prior to initial use, all new, altered, modified or extensively repaired cranes shall be inspected by a designated person to insure compliance with provisions of this standard.

2. Regular inspection.

Inspection procedure for cranes in regular service is divided into two general classifications based upon the intervals at which inspection should be performed. The intervals in turn are dependent upon the nature of the components of the crane and the degree of their exposure to wear, deterioration, or malfunction. The two general classifications are herein designated as "frequent" and "periodic" with respective intervals between inspections as defined below.

- A. Frequent inspection - daily or before each use
- B. Periodic inspection - one to twelve-month intervals or as specifically recommended by the manufacturer or qualified person.

**DESIGNATED PERSONNEL SHALL
PERFORM INSPECTIONS ONLY.**

FREQUENT INSPECTION

Inspections should also occur during operation for any deficiencies that might appear between regular inspections. Any deficiencies, such as those listed below, shall be carefully examined and a determination made as to whether they constitute a hazard:

1. Inspect control mechanisms for maladjustment that interferes with proper operation.
2. Inspect control mechanisms for excessive wear of components and contamination by lubricants or other foreign matter.

3. Inspect safety devices for malfunction.
4. Visually inspect all hydraulic hoses, particularly those that flex in normal operation of crane functions.
5. Inspect hooks and latches for deformation, chemical damage, cracks, and wear. Refer to ANSI/ASME B30.10.
6. Inspect for proper rope reeving.
7. Inspect electrical wiring and components for malfunctioning, signs of excessive deterioration, dirt and moisture accumulation.
8. Inspect hydraulic system for proper oil level and leaks.
9. Inspect tires for recommended inflation pressure, cuts and loose wheel nuts.
10. Inspect connecting pins and locking device for wear damage and loose retaining bolts.
11. Inspect rope for gross damage, such as listed below, which may be an immediate hazard.
 - A. Distortion such as kinking, crushing, unstranding, birdcaging, main strand displacement, or core protrusion. Loss of rope diameter in a short length or unevenness of outer strands should be replaced.
 - B. General corrosion.
 - C. Broken or cut strands.
 - D. Use care when inspecting sections of rapid deterioration around flange points, crossover points, and repetitive pickup points on drums.
 - E. Inspect number, distribution, and type of visible broken wires. Reference Rope Maintenance section in the owner's manual.

Continued use of rope depends upon good judgment by a designated person in evaluating remaining strength in a used rope after allowance for deterioration disclosed by inspection. Continued rope operation depends upon this remaining strength.

INSPECTION REQUIREMENTS

PERIODIC INSPECTION

Any deficiencies, such as those listed below, shall be carefully examined and determination made as to whether they constitute a hazard:

1. Inspect for deformed, cracked or corroded members in the crane structure and entire boom.
2. Inspect for loose bolts, particularly mounting bolts.
3. Inspect for cracked or worn sheaves and drums.
4. Inspect for worn, cracked, or distorted parts such as pins, bearings, shafts, gears, rollers and devices.
5. Inspect for excessive wear on brake and clutch system parts and lining.
6. Inspect crane hooks for cracks.
7. Inspect travel steering, braking, and locking devices for malfunction.
8. Inspect for excessively worn or damaged tires.
9. Inspect hydraulic hose, fittings, and tubing for the following problems:
 - A. Evidence of leakage at the surface of the flexible hose or its junction with metal and coupling.
 - B. Blistering, or abnormal deformation to the outer covering of the hydraulic or pneumatic hose.
 - C. Leakage at threaded or clamped joints that cannot be eliminated by normal tightening or recommended procedures.
 - D. Evidence of excessive abrasion or scrubbing on the outer surface of a hose, rigid tube, or fitting. Means shall be taken to eliminate the interference of elements in contact or otherwise protect the components.
10. Inspect hydraulic pumps and motors for the following problems:
 - A. Loose bolts and fasteners.
 - B. Leaks at joints between sections.
 - C. Shaft seal leaks.
 - D. Unusual noises or vibrations.
 - E. Loss of operating speed.
 - F. Excessive heating of the fluid.
 - G. Loss of pressure.
11. Inspect hydraulic valves for the following problems:
 - A. Cracks in valve housing.
 - B. Improper return of spool to neutral position.
 - C. Leaks at spools or joints.
 - D. Sticking spools.
 - E. Failure of relief valves to attain or maintain correct pressure setting.
 - F. Relief valve pressure shall be checked as specified by the manufacturers.
12. Inspect hydraulic cylinders for the following problems:
 - A. Drifting caused by fluid leaking across piston.
 - B. Rod seals leaking.
 - C. Leaks at welding joints.
 - D. Scored, nicked, or dented cylinder rods.
 - E. Damaged case (barrel).
 - F. Loose or deformed rod eyes or connecting joints.
13. Inspect hydraulic filters for evidence of rubber particles on the filter elements indicating possible hose, "O" ring, or other rubber component deterioration. Metal chips or pieces on the filter may denote failure in pumps, motors, or cylinders. Further inspection will be necessary to determine the origin of the problem before corrective action can be taken.
14. Inspect labels to confirm correct location and legibility. Reference decal layout in this manual for proper location of decals.
15. **Rope Inspections need not be at equal calendar intervals and should be more frequent as the rope approaches the end of useful life.** A qualified person shall inspect the wire rope based on such factors as:
 - A. Expected rope life as determined by experience on the particular installation or similar installations.
 - B. Severity of environment.
 - C. Percentage of capacity lifts.
 - D. Frequency rates of operation.
 - E. Exposure to shock loads.This inspection shall cover the entire length of the rope. Only the surface wires need to be inspected and no attempt should be made to open the rope. Any deterioration resulting in appreciable loss of original strength shall be noted and determination made as to whether use of the rope would constitute a hazard. A few notable deterioration points are listed below:

INSPECTION REQUIREMENTS

- A. Reduction of rope diameter below nominal diameter due to loss of core support.
- B. Internal or external corrosion.
- C. Wear of outside wires.
- D. Severely corroded, cracked, bent, worn, or improperly applied connections.

CRANES NOT IN REGULAR USE

A crane, which has been idle for a period of over one month or more, shall be given an inspection conforming to the "initial" and "regular" inspection requirements of this section.

INSPECTION RECORDS

Dated records of periodic inspection should be made on critical items such as brakes, crane hooks, rope, cylinders, and relief pressure valves.

TESTING REQUIREMENTS

REFERENCE ASME B30.5a AND OSHA 1910.180 FOR COMPLETE TESTING REQUIREMENTS

TESTING SHALL BE PERFORMED BY DESIGNATED PERSONNEL ONLY.

Prior to initial use, all new, altered, modified, or extensively repaired cranes shall be tested for compliance with the operational requirements of this crane.

Test requirements:

1. Test all functions to verify speed and operation.
2. Check that all safety devices are working properly.
3. Confirm operating controls comply with appropriate function labels.
4. Test loads shall not exceed 110% of the manufacturer's load rating.
5. Written reports shall be maintained showing test procedures and confirming the adequacy of repairs.

GENERAL REPAIRS AND MAINTENANCE

REFERENCE ASME B30.5a AND OSHA 1910.180 FOR COMPLETE MAINTENANCE AND REPAIR REQUIREMENTS

A preventative maintenance program should be established based on this section and all replacement parts should be obtained from AutoCrane Company.

For replacement parts contact your local authorized distributor.

MAINTENANCE PRECAUTIONS

1. Place crane where it will cause the least interference with other equipment or operations.
2. Verify all controls are in the "off" position and all operating features secured from inadvertent motion by brakes, pawls, or other means.
3. The means for starting the crane shall be rendered inoperative.
4. The boom should be secured in place before maintenance.
5. Relieve hydraulic oil pressure from all hydraulic circuits before loosening or removing hydraulic components.
6. Warning or "OUT OF ORDER" signs shall be placed on all crane controls.
7. After adjustments and repairs have been made, the crane shall not be returned to service until all guards have been reinstalled, trapped air removed from hydraulic system (if required), safety devices reactivated, and maintenance equipment removed.

ADJUSTMENTS AND REPAIRS

1. Any hazardous conditions disclosed by the inspection requirements shall be corrected before operation of crane is resumed. Only designated personnel shall do adjustments and repairs.
2. Adjustments shall be maintained to assure correct functioning of components, the following are examples:
 - A. Functional operating mechanism.
 - B. Safety devices.
 - C. Control systems.
3. Repairs or replacements shall be provided as needed for operation, the following are examples:
 - A. Critical parts of functional operating mechanisms which are cracked, broken, corroded, bent, or excessively worn.

- B. Critical parts of the crane structure which are cracked, bent, broken, or excessively corroded.
 - C. Crane hooks showing cracks, damage, or corrosion shall be taken out of service. Repairs by welding are not recommended.
4. If bleeding the hydraulic system is required, run each crane function until smooth operation of that particular function is noticeable.

LUBRICATION

All moving parts of the crane, for which lubrication is specified, should be regularly lubricated per the manufacturer's recommendations and procedures. **Reference Lubrication and Maintenance Schedule in this manual.**

ROPE REPLACEMENT

No precise rules can be given for determination of the exact time for replacement of rope, since many variable factors are involved.

1. Conditions such as the following shall be reason for questioning continued use of the rope or increasing the frequency of inspection:
 - A. In running ropes, six randomly distributed broken wires in one lay or three broken wires in one strand in one lay.
 - B. One outer wire broken at the contact point with the core of the rope structure and protrudes or loops out of the rope structure. Additional inspection of this section is required.
 - C. Wear of one third of the original diameter of the outside individual wire.
 - D. Kinking, crushing, bird caging, or any other damage resulting in distortion of the rope structure.
 - E. Evidence of any heat damage from any cause.
 - F. Reduction from nominal diameter of more than 1/64 in. (0.4mm) for diameters up to and including 5/16 in. (8 mm), 1/32 in. (0.8 mm) for diameter 3/8 in. (9.5 mm) to and including 1/2 in. (13 mm), 3/64 in. (1.2 mm) for diameter 9/16 in. (14.5 mm) to and including 3/4 in. (19 mm), 1/16 in. (1.6 mm) for diameter 7/8 in. (22 mm) to and including 1 1/8 in. (29 mm), 3/32 in.

GENERAL REPAIRS AND MAINTENANCE

(2.4 mm) for diameters 1 1/4 in. (32 mm) to and including 1 1/2 in. (38 mm).

- G. In standing ropes, more than two broken wires in one lay in sections beyond end connections or more than one broken wire at an end connection.
2. Replacement rope shall have a strength rating at least as great as the original rope furnished or recommended by AutoCrane. A rope manufacturer, AutoCrane, or a qualified person shall specify any deviation from the original size, grade, or construction.

ROPE MAINTENANCE

1. Rope should be stored to prevent damage or deterioration.
2. Unreeling or uncoiling of rope shall be done as recommended by the rope manufacturer and with care to avoid kinking or inducing twist.
3. Before cutting a rope, seizing shall be placed on each side of the place where the rope is to be cut to prevent unlaying of the strands. On pre-formed rope, one seizing on each side of the cut is required. On non-preformed ropes of 7/8 in. (22 mm) diameter or smaller, two seizings on each side of the cut are required, and for non-preformed rope 1 in. (25 mm) diameter or larger, three seizings on each side of the cut are required.
4. During installation care should be exercised to avoid dragging of the rope in the dirt or around objects that will scrape, nick crush or induce sharp bends in it.
5. Rope should be maintained in a well-lubricated condition. It is important that lubricant applied as a part of a maintenance program shall be compatible with the original lubricant and to this end the rope manufacturer should be consulted. Lubricant applied shall be the type that does not hinder visual inspection. Those sections of rope that are located over sheaves or otherwise hidden during inspection and maintenance procedures require special attention when lubricating rope. The object of rope lubrication is to reduce internal friction and to prevent corrosion.
6. When an operating rope shows greater wear or well-defined localized areas than on the remainder of the rope, rope life can be extended in some cases by shifting the wear to different areas of the rope.

MAINTENANCE OF BATTERIES

Maintenance of Auto Crane unit batteries differs very little from the generally prescribed maintenance of any lead acid battery. All batteries must be kept properly charged, properly filled with water, and relatively clean.

Keep Properly Charged

Many things affect the proper charge to a battery, such as:

1. Regulator settings.
2. Proper tightness of belts on the alternator or generator.
3. Good, clean connections of all cables and wires at the following places:
 - a. Battery.
 - b. Regulator.
 - c. Starting motor.
 - d. Alternator or generator.
 - e. Ground connections (most important).

It is of extreme importance to keep the battery as fully charged as possible without overcharging, especially when vehicles are left outside for extended periods in extremely cold climates. A battery can freeze. Freezing points for various specific gravities of acid are as follows:

Specific Gravity (Corrected to 80°F)	Freezing Temp. Degrees F.
1.280	-90°F
1.250	-62°F
1.200	-16°F
1.150	5°F
1.100	19°F

As shown, a half-charged battery (about 1.100 specific gravity) cannot stand for any length of time at 20°F or it will freeze.

The main reason for keeping the battery as fully charged as possible without over-charging is to insure that power is available even though the vehicle has been standing for some time.

Keep Properly Filled with Water

The battery should *always* be properly filled with water. If the electrolyte level is allowed to fall below the top of the plates, the results become threefold:

1. The exposed portion of the plate will become sulfated.
2. The portion of the plate exposed is not usable.
3. That portion of the acid remaining becomes more concentrated and may cause more rapid

deterioration of the remaining parts of the battery.

Keep A Relatively Clean Battery

The battery should be kept clean. Batteries filled with acid and which are not in use self-discharge to a limited degree because of the nature of the materials within the battery. If dirt is allowed to collect on the top of the battery (and this dirt absorbs moisture) and electrical path can be set up between the various terminals of the battery and the ground. Once such a path has been established, the self-discharge of the battery is accelerated. This also accelerates corrosion of the battery cables at the terminals.

Periodic Maintenance is Needed

A definite program of periodic maintenance of all batteries should be conducted on a regular basis. Periodic maintenance includes:

1. Checking belts for tightness on the charging equipment.
2. Checking battery electrolyte levels.
3. Checking cables for good connections.
4. Cleaning where corrosion is apparent.

When corrosion is cleaned off, the cable terminals and battery terminals should be coated with a light coating of petroleum jelly before they are replaced. When terminals are cleaned, the top of the battery should be cleaned with a mild solution of soda water.

Low Maintenance Batteries (Maintenance Free)

Low maintenance batteries should not be used on AutoCrane Cranes or trucks equipped with AutoCrane Cranes. The batteries are not designed for "deep" discharge.

Testing Your Battery

If the condition of the battery is in question, it should be removed from the vehicle, taken to the shop, and allowed to reach room temperature. It should then be recharged until specific gravity readings taken at one-half hour intervals. If the specific gravity readings are fairly uniform, the battery should be checked with a high rate tester. Use the tester in accordance with the manufacturer's instructions. The high rate tester is the best method to test a questionable battery.

MAINTENANCE OF BATTERIES

If, after charging, it is noted that the specific gravity reading of one cell is 30 points less than any of the other cells, it may be assumed that the cell is bad and that the battery should be replaced. If all cells are uniform but not up to full charge, a low rate of charge should be attempted for an extended time. This usually will recover a badly sulfated battery.

Replacing a Battery

If it is necessary to replace a battery, and a dry charge battery is used, the following procedure applies:

1. Fill the battery with electrolyte of the proper specific gravity.

2. Place the battery on charge according to the manufacturer's instructions.

It is essential that the second step above be followed to ensure that the battery going on the vehicle is fully charged.

It is also very important that the battery hold-downs be checked periodically to insure that the batteries are properly positioned to avoid vibration problems, breakage of cables or terminals. Care must be taken to avoid cracking or breaking containers or covers by tightening hold-down fixtures excessively. They also must not be so loose that breakage results from a hold-down that is too loose.

6406H

LUBRICATION & MAINTENANCE SCHEDULE

SERVICE PERFORMED	DAY	WKLY	3 MOS	6 MOS	YEAR	NOTES
LOAD HOOK	X					INSPECT HOOK & LATCH FOR DEFORMATION, CRACKS, & CORROSION
CABLE DRUM	X					MAKE SURE CABLE IS WOUND EVENLY ON DRUM
HOIST / BOOM CABLE	X					CHECK FOR FLATTENING, KINKS, & BROKEN STRANDS, SEE MANUAL
HYD. HOSES	X					VISUAL INSPECTION
HYD. FLUID	X					CHECK FLUID LEVEL
PIN RETAINING BOLTS	X					CHECK TORQUE TO 23 FT-LBS (GRADE 5), 35 FT-LBS (GRADE 8) AS REQUIRED
MOUNTING BOLTS		X				CHECK TORQUE TO 501 FT-LBS AS REQUIRED
ROTATION RING GEAR		X				LUBE WITH MOBILETAC LL, OR LUBRIPLATE P/N 15263, OR EQUAL
SHEAVE BEARINGS		X				SEALED BEARING, REPLACE IF ROUGH OR LOOSE
ALL OTHER BOLTS		X				CHECK TIGHTEN AS REQUIRED
LIFT CYLINDER BEARINGS			X			GREASE WITH MOBILEPLEX EP-2 OR EQUIVALENT @ ZERKS
ROTATION BEARING			X			GREASE WITH MOBILEPLEX EP-2 OR EQUIVALENT @ ZERKS
ROTATION BEARING BOLTS			X			CHECK TORQUE TO 170 FT-LBS (HEX HEAD) 180 FT-LBS (SOCKET HEAD) AS REQUIRED
ROTATION GEAR BOX			X			CHECK TORQUE TO 90 FT-LBS (SOCKET HEAD) AND 55 FT-LBS (HEX HEAD) AS REQUIRED
ROTATION GEAR BOX				X		EP GEAR LUBE SAE 80-90
HYDRAULIC FLUID					X	DRAIN, FLUSH, AND REFILL WITH MOBILE DTE 13 OIL
BOOM SLIDE PADS	PADS GREASED WHEN REPLACED					
FOR ADDITIONAL INFORMATION SEE:	1) OWNER'S MANUAL 2) OSHA SECTION 1910.180 3) ANSI B30.5-1989					

CAUTION: Routine maintenance insures trouble-free operation and protects your investment. All warranties are void if maintenance is neglected.

6406H

LUBRICATION & MAINTENANCE SCHEDULE

NOTES:

1. Use only authorized parts. Any damage or malfunction caused by the use of unauthorized parts is not covered by Warranty or Product Liability.
2. Once a bolt has been torqued to its rated capacity and then removed; the bolt should be replaced with a new one.
3. Auto Crane Company recommends that this crane be serviced per "Crane Inspection Log" P/N 999978. These logs should be filled in at the intervals noted and kept as a permanent record. Additional copies are available from your local distributor.

6406H

SAFETY DECAL SECTION

PART NO.: 040579000
 DECAL: OPERATING INSTRUCTIONS
 FUNCTION: To inform the operator of the proper procedure to follow for safe operation of the crane.
 USED ON: All Cranes
 QUANTITY: 1
 PLACEMENT: Right side plate

⚠ CAUTION

1. INSPECT VEHICLE AND CRANE INCLUDING OPERATION, PRIOR TO USE DAILY.
2. DO NOT USE THIS EQUIPMENT EXCEPT ON SOLID, LEVEL SURFACE WITH OUTRIGGERS PROPERLY EXTENDED AND CRANE MOUNTED ON FACTORY-RECOMMENDED TRUCK.
3. BEFORE OPERATING THE CRANE, REFER TO MAXIMUM LOAD (CAPACITY) CHART ON CRANE FOR OPERATING (LOAD) LIMITATIONS.
4. OPERATE ALL CONTROLS SLOWLY AND SMOOTHLY.
5. KEEP LOAD UNDER BOOM TIP. DO NOT SIDE LOAD BOOM OR DRAG LOADS. AVOID FREE SWINGING LOADS.
6. DO NOT OPERATE, WALK OR STAND BENEATH BOOM OR A SUSPENDED LOAD.
7. KEEP AT LEAST 5 WRAPS OF LOADLINE ON HOIST DRUM.
8. FOR TRAVELING, BOOM AND OUTRIGGERS MUST BE IN THE STOWED POSITION.
9. ALL REMOVABLE PENDANTS MUST BE STORED IN CAB OR TOOL COMPARTMENT WHEN CRANE IS NOT IN USE.

P/N 040579

PART NO.: 040580000
 DECAL: OPERATING TRAINING
 FUNCTION: To inform the operator of the need to receive proper training before using the crane.
 USED ON: All Cranes
 QUANTITY: 1
 PLACEMENT: Right side plate

⚠ DANGER

AN UNTRAINED OPERATOR
SUBJECTS HIMSELF AND
OTHERS TO

DEATH OR SERIOUS INJURY

- 1.) YOU MUST HAVE BEEN TRAINED IN THE OPERATION OF THIS CRANE, AND
- 2.) YOU MUST KNOW AND FOLLOW THE SAFETY AND OPERATING RECOMMENDATIONS CONTAINED IN THE MANUFACTURER'S MANUAL, YOUR EMPLOYER'S WORK RULES AND APPLICABLE GOVERNMENT REGULATIONS.

P/N 040580

PART NO.: 040632000
 DECAL: TAMPERING WITH OVERLOAD DEVICE
 FUNCTION: To inform the operator that tampering with the overload device may cause a unit failure or possible personal injury.
 USED ON: All Cranes equipped with a load sensor
 QUANTITY: 1
 PLACEMENT: Right side of valve sensor.

⚠ WARNING

TAMPERING WITH OVERLOAD DEVICE VOIDS WARRANTY. OVERLOADED CRANE MAY HYDRAULICALLY RELEASE AND LET LOAD DOWN TO GROUND. OVERLOAD PROTECTION DEVICE CANNOT FUNCTION WITH BOOM BELOW HORIZONTAL (0°). HOIST UP, BOOM DOWN, AND EXTEND OUT WILL BE INOPERATIVE WHEN CRANE IS IN OVERLOAD CONDITION.

P/N 040632

6406H SAFETY DECAL SECTION

PART NO.: 040529000
 DECAL: ELECTROCUTION HAZARD
 FUNCTION: To inform the operator of the hazard involved with contacting electrical power lines with crane boom.
 USED ON: All Cranes
 QUANTITY: 2
 PLACEMENT: Both sides of end of lower boom

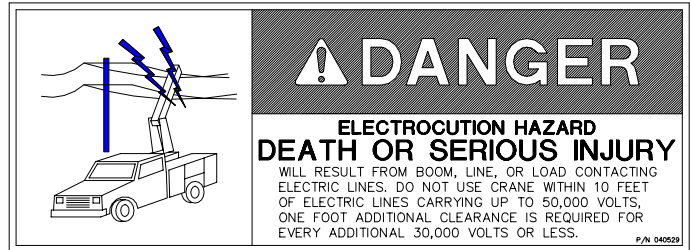

PART NO.: 040517000
 DECAL: STAY CLEAR OF BOOM
 FUNCTION: To inform the operator of the hazard of proximity or contact with the crane boom during operation.
 USED ON: All Cranes
 QUANTITY: 2
 PLACEMENT: Both sides of crown

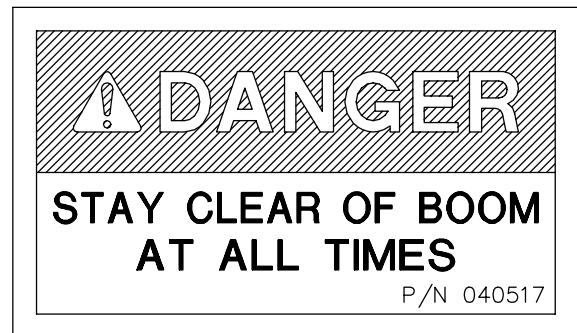

PART NO.: 040518000
 DECAL: STAY CLEAR OF LOAD
 FUNCTION: To inform the operator of the hazard of proximity or contact with the crane load during operation.
 USED ON: All Cranes
 QUANTITY: 2
 PLACEMENT: Both sides of traveling block



6406H

SAFETY DECAL SECTION

PART NO.: 040587000 USED ON: All cranes equipped with a load sensor.

DECAL: LOAD SENSOR, DON'T TAMPER QUANTITY: 2

FUNCTION: To inform the operator that the load sensor is pre-set and that tampering with the sensor may cause potentially hazardous situation. PLACEMENT: Both sides of the lift cylinder near the load sensor

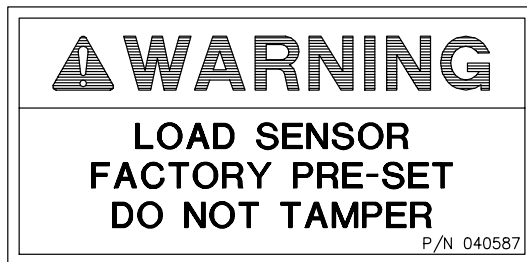

PART NO.: 040519000 USED ON: All cranes.

DECAL: SCISSORS POINT QUANTITY: 2

FUNCTION: To inform the operator of possible danger at scissors point on crane. PLACEMENT: Both sides of the lift cylinder

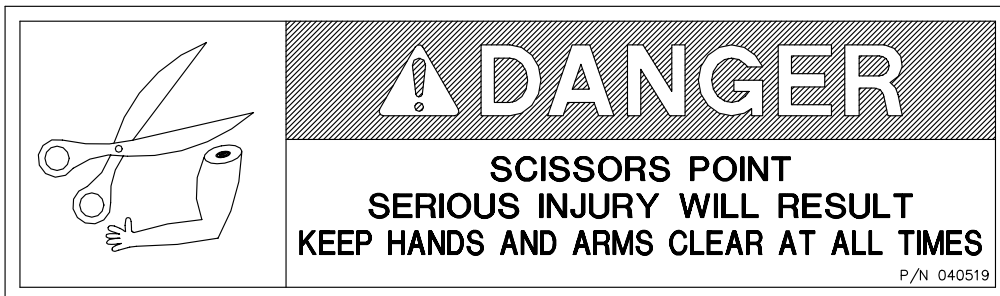

6406H DECAL LAYOUT

P/N: 366733000

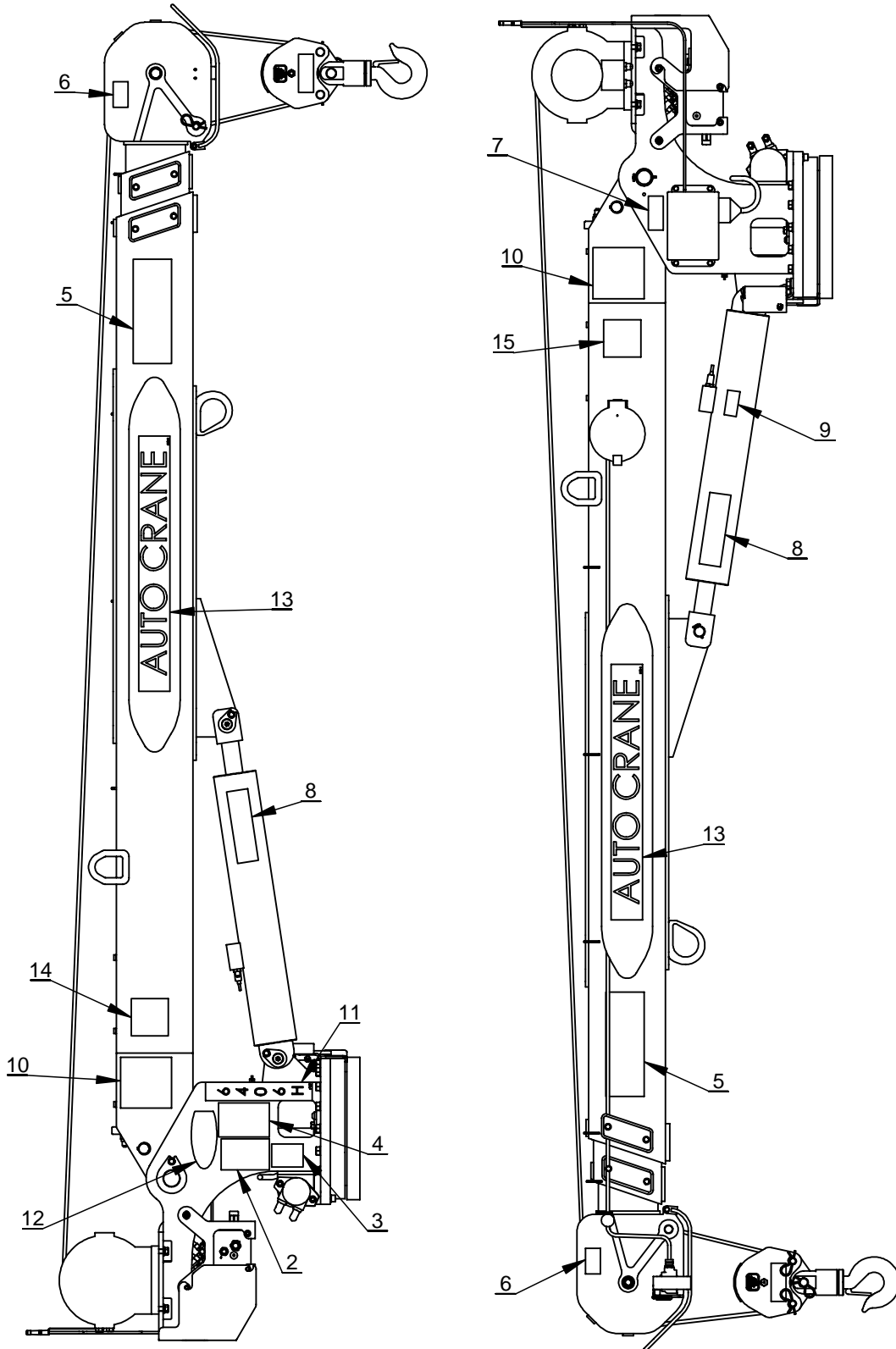

6406H DECAL LAYOUT

P/N: 366733000

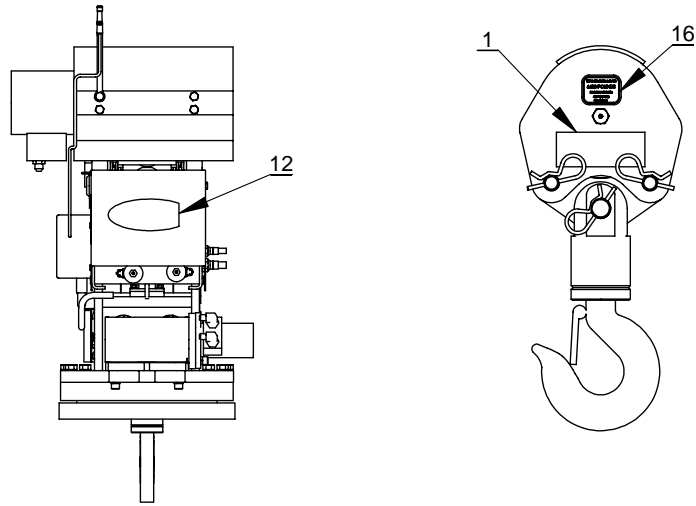

ITEM NO.	QTY.	PART NO.	DESCRIPTION
1	2	040518000	DECAL DANGER "STAY CLEAR OF LOAD"
2	1	040579000	DECAL OPERATION INSTRUCTIONS
3	1	040632000	DECAL WARNING - OVERLOAD
4	1	040580000	DECAL TRAINED OPERATOR
5	2	040529000	DECAL POWER LINE HAZARD
6	2	040517000	DECAL STAY CLEAR OF BOOM
7	1	330622000	DECAL SERIAL NO
8	2	040519000	DECAL DANGER SCISSOR POINT
9	1	040587000	DECAL WARNING LOAD SENSOR
10	2	366724000	DECAL LOAD CHART 6406H
11	1	366390000	DECAL 6406H
12	2	360034000	DECAL AUTO CRANE LOGO
13	2	366389000	DECAL AUTO CRANE
14	1	320318000	DECAL ANGLE IND RIGHT
15	1	320318001	DECAL ANGLE IND STREET SIDE
16	1	366399000	DECAL MAX BLOCK LOAD

NOTES

6406H GENERAL DIMENSIONS

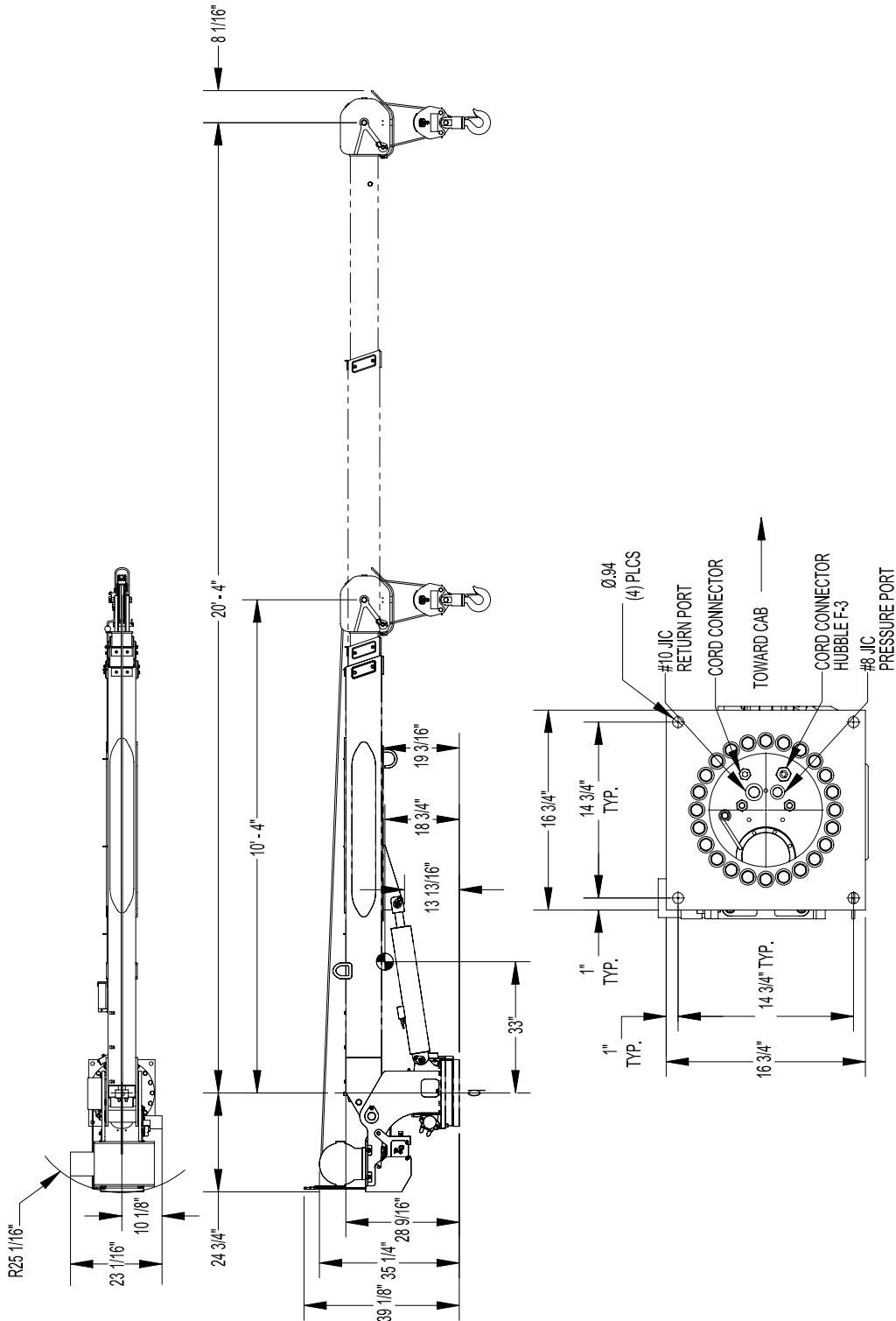

NOTE: C.G. IS APPROXIMATE

6406H

MOUNTING AND INSTALLATION

1. Check to make sure the following items are with your crane. Please note the different, model specific, quantities.

ITEM	QTY FM	QTY HW	PART NO.	DESCRIPTION
1	1	1	480689	FUSE 15 AMP TIME-DELAY
2	1	1	480688	FUSE HOLDER IN-LINE WATERPROOF
3	120"	120"	800596	WIRE 16G 600V 1C YEL
4	6	6	634401	TIE CABLE - MEDIUM
5	6	6	750738	STICK-ON
6	5	5	320357	TERMINAL NON-INS S/O W/L
7	1	1	320363	PLUG TERMINAL CONNECTOR
8	1	1	340638	CONDUCTOR POWER
9	1	1	320355	POWER RELAY
10	4	4	018900	NUT HX 7/8 NF GR8
11	4	4	022200	WASHER SP LK 7/8
12	1		460100002	TRANSMITTER
13	1		366500009	CABLE PENDANT/CHARGE
14	1		366504000	BATTERY CHARGER CIGARETTE LIGHTER
15	4	4	015104	7/8-14 X 5 HH GR8
16	1	1	366724000	DECAL LOAD CHART 6406H
17	1	1	366900000	MANUAL 6406H
18	1		360708000	BRACKET PENDANT PLUG
19	4		725321	NUT NYLON LOCK 8-32
20	4		001302	SCREW 8-32 X .5
21		1	366520002	JUNCTION BOX ASSY
22		1	366466000	WIRE HARNESS, TRUCK FUNCTIONS
23		1	680040	PENDANT ASSEMBLY

2. Pressure and return hoses are not furnished with this crane. The hoses must be provided by the installer and the lengths determined at installation.

REQUIREMENTS FOR INSTALLATION USING 23 GALLON RESERVOIR(*)

- A. **RETURN LINE** FROM CRANE TO RESERVOIR (IN COMPARTMENT): -10 SAE 100R2 (OR EQUIVALENT). HOSE LENGTH IS DETERMINED BY INSTALLER. RETURN LINES LONGER THAN 6 FEET SHOULD BE SIZE -12. HOSE END FITTINGS ARE -10 JIC FEMALE SWIVEL (CRANE END) AND -10 JIC FEMALE SWIVEL (RESERVOIR END).
- B. **PRESSURE LINE** FROM PUMP TO CRANE: -8 SAE 100R12 (OR EQUIVALENT) WITH A **2,850 PSI MINIMUM WORKING PRESSURE**. HOSE LENGTHS IS DETERMINED BY INSTALLER. HOSE END FITTINGS ARE BOTH -8 JIC FEMALE SWIVEL.

(*) NOTE: 23 GAL RESERVOIR IS MINIMUM REQUIREMENT FOR CRANE ONLY. THE ADDITION OF OTHER AUXILLARY EQUIPMENT WILL REQUIRE ADDITIONAL CAPACITY.

CAUTION – FAILURE TO USE CLEAN HYDRAULIC HOSES AND COMPONENTS MAY CONTAMINATE THE CRANE AND HYDRAULIC SYSTEM AND VOID WARRANTY.

3. Crane must be provided with a flow of 8 gallons per minute and a pressure of 2,750 PSI. Excess flow will cause erratic operation, and too little flow will cause poor crane operation.
4. Vehicle should meet minimum GVW rating of 14,500 pounds.
5. The vehicle **MUST** be equipped with an engine speed control and tachometer.
6. Make sure mounting surface is properly reinforced to withstand 38,000 ft-lb capacity loading of crane and that outriggers are used to provide total stability for the truck.

6406H

MOUNTING AND INSTALLATION

7. A 13 1/2" diameter hole should be cut out of mounting location (centered with mounting bolts) for access to hydraulic connections.
8. Make sure the mounting bolts are 7/8" dia, grade 8-UNF. Torque bolts to 501 ft-lbs.
9. When crane is not in operation, a boom support should always be used. Traveling block should be connected to hook loop.
10. Electrical hookup:
Wiring (FM – cable from base of crane, HW – cable from junction box):
 - A. CONNECT THE BLACK WIRE TO THE BATTERY NEGATIVE (GROUND).
 - B. CONNECT THE RED WIRE TO FUSED 12VDC POWER. 12VDC POWER SHOULD BE SUPPLIED THROUGH A DEDICATED SWITCH THAT IS POWERED ONLY WHEN THE IGNITION SWITCH IS ON.
 - C. OPTIONALLY, USE THE WHITE WIRE FOR ENGINE FAST/SLOW (12VDC MAINTAINED-FM ONLY).
 - D. OPTIONALLY, USE THE BLUE WIRE FOR ENGINE START.
 - E. OPTIONALLY, USE THE ORANGE WIRE FOR ENGINE STOP.
 - F. OPTIONALLY, USE THE GREEN WIRE FOR AUXILIARY (12VDC MAINTAINED-FM ONLY).

NOTE: ALL ELECTRICAL CONNECTIONS BETWEEN THE CRANE AND THE VEHICLE SHOULD BE MADE USING RELAYS TO ISOLATE THE ELECTRICAL SYSTEMS OF EACH AS MUCH AS POSSIBLE.

WARNING! FAILURE TO CORRECTLY PLUMB AND WIRE CRANE CAN CAUSE INADVERTENT OPERATION AND DAMAGE TO CRANE AND/OR PERSONNEL!

11. Once crane and plumbing are installed on the truck, fill the reservoir to top of sight glass (mobile DTE 13 or equal). Before operating crane, connect together the pressure and return hoses going to base of crane using 10-12 JIC union and engage PTO with engine running. Allow oil to circulate for 15 to 20 minutes. This will flush contaminants from the system back to the return line filter. Operate all cylinders to full extension and retraction a minimum of six times, to bleed air from system. Return all cylinders to the stored position and disengage PTO. Refill reservoir to top sight glass. To ensure 8 gallons per minute (GPM), install an in-line flow meter between the crane and the reservoir in the return hose.
12. Load test the crane to ensure proper functioning and truck stability.
13. Make certain the owner's manual is delivered to the customer.
14. For additional help: call the service department at the Auto Crane Company (918) 836-0463 (Tulsa, Oklahoma).

WARNING

FEDERAL LAW (49 CFR PART 571) REQUIRES THAT THE FINAL STAGE MANUFACTURER OF A VEHICLE CERTIFY THAT HE VEHICLE COMPLIES WITH ALL APPLICABLE FEDERAL REGULATIONS. ANY MODIFICATIONS PERFORMED ON THE VEHICLE PRIOR TO THE FINAL STAGE ARE ALSO CONSIDERED INTERMEDIATE STAGE MANUFACTURING AND MUST BE CERTIFIED AS TO COMPLIANCE. THE INSTALLER OF THIS CRANE AND BODY IS CONSIDERED ONE OF THE MANUFACTURERS OF THE VEHICLE. AS SUCH A MANUFACTURER, THE INSTALLER IS RESPONSIBLE FOR COMPLIANCE WITH ALL APPLICABLE FEDERAL AND STATE REGULATIONS, AND IS REQUIRED TO CERTIFY THAT THE VEHICLE IS IN COMPLIANCE.

IT IS THE FURTHER RESPONSIBILITY OF THE INSTALLER OF THE CRANE TO COMPLY WITH THE OSHA TRUCK CRANE STABILITY REQUIREMENTS AS SPECIFIED BY 29 CFR PART 1910.180 (C) (1).

6406H GENERAL ASSEMBLY HARDWIRED - P/N: 366720001

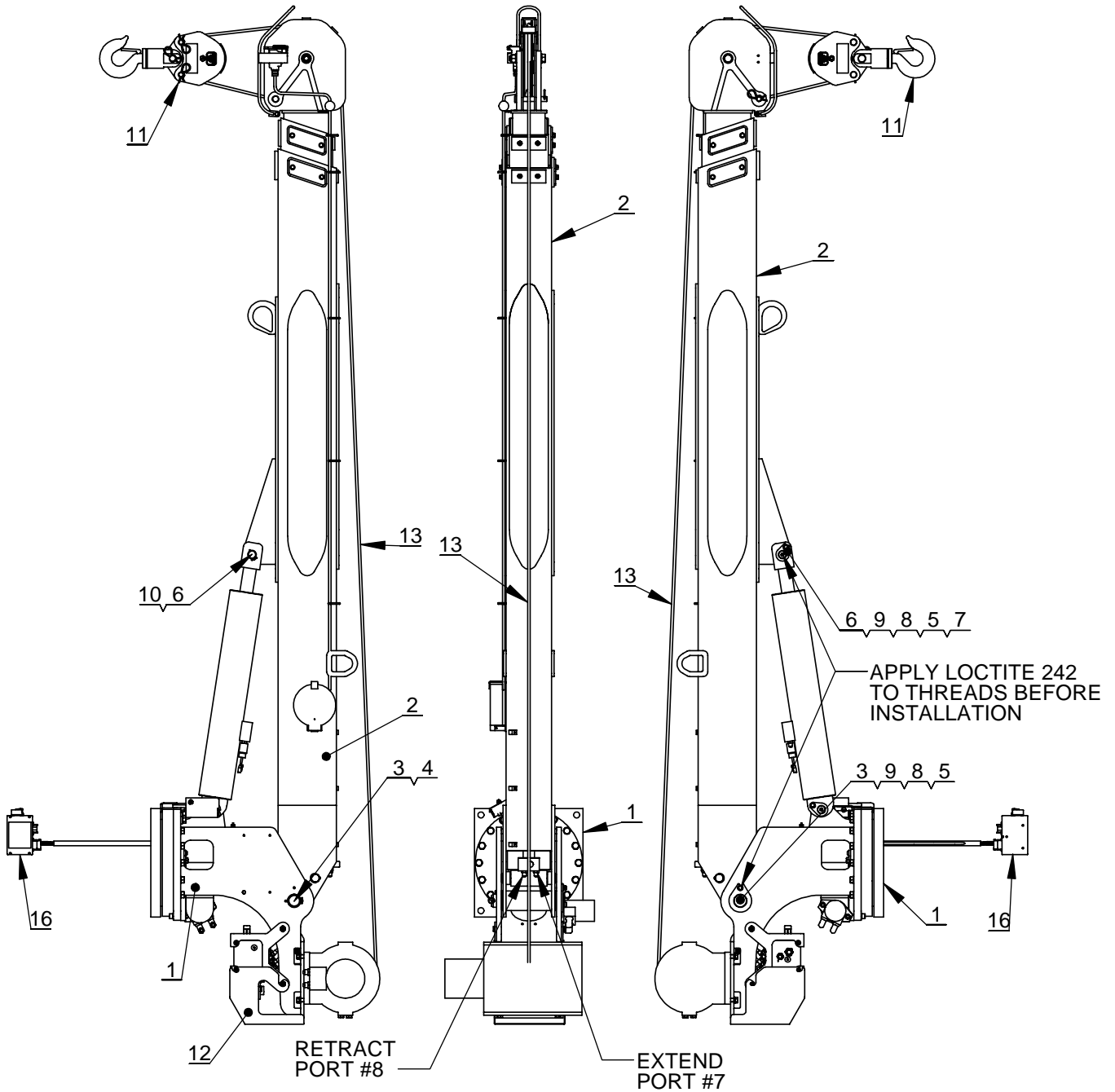

ELECTRICAL SCHEMATIC P/N: 366372000
HYDRAULIC SCHEMATIC P/N: 366366000

**6406H GENERAL ASSEMBLY
HARDWIRED - P/N: 366720001**

ITEM NO.	QTY.	PART NO.	DESCRIPTION
1	1	366740001	PEDESTAL ASSEMBLY
2	1	366630000	BOOM ASSEMBLY
3	1	360675000	PIN, BOOM PIVOT
4	1	360677000	PIN, 1/4 COTTERLESS RING
5	2	008702000	SCW HX 3/8-16 X 1 1/4 GR5
6	1	360676000	PIN, CYLINDER
7	1	239300000	ZERK, GREASE
8	2	021100000	WASHER SP LK 3/8
9	2	320976000	WASHER, FLAT, 3/8 SAE HARDENED
10	1	360678000	PIN, 3/16 COTTERLESS RING
11	1	366398000	TRAVELING BLOCK ASSY 6406H
12	1	366430000	COVER 6406
13	1	480841000	ROPE ASSY
14	1	366341000	SHIP KIT, 6406H HARDWIRED CRANE
15	1	366733000	6406 DECAL LAYOUT
16	1	366520002	JUNCTION BOX ASSEMBLY

6406H PEDESTAL ASSEMBLY HARDWIRED - P/N: 366740001

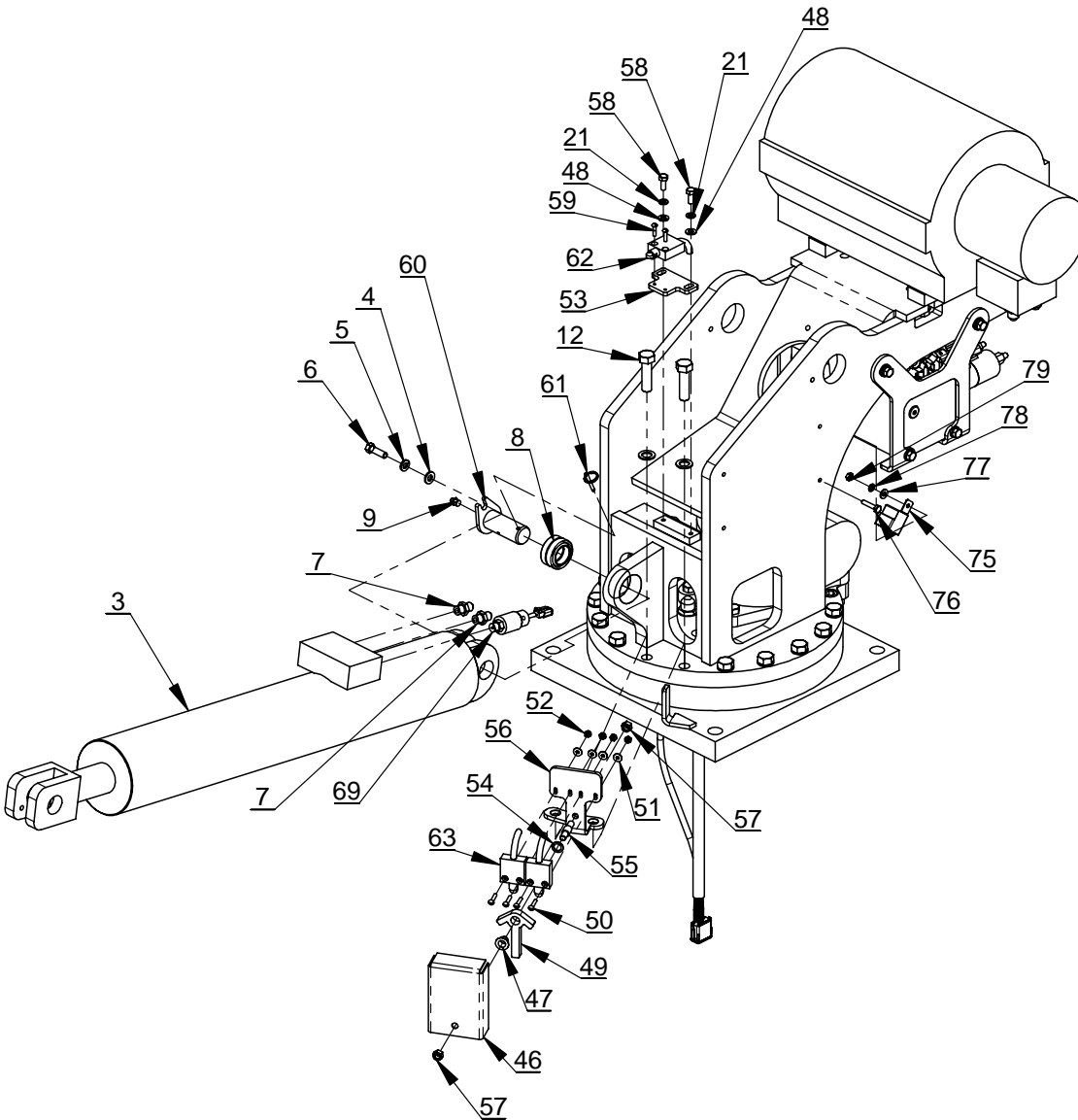

HYDRAULICS:

- PORT #1: HOIST DOWN
- PORT #2: HOIST UP
- PORT #3: ROTATION CW
- PORT #4: ROTATION CCW
- PORT #5: LIFT CYL EXTEND
- PORT #6: LIFT CYL RETRACT
- PORT #7: EXT CYL EXTEND
- PORT #8: EXT CYL RETRACT

CYLINDER SEAL KIT: 366342001
 COUNTER BALANCE CARTRIDGE: 480188000

6406H PEDESTAL ASSEMBLY HARDWIRED - P/N: 366740001

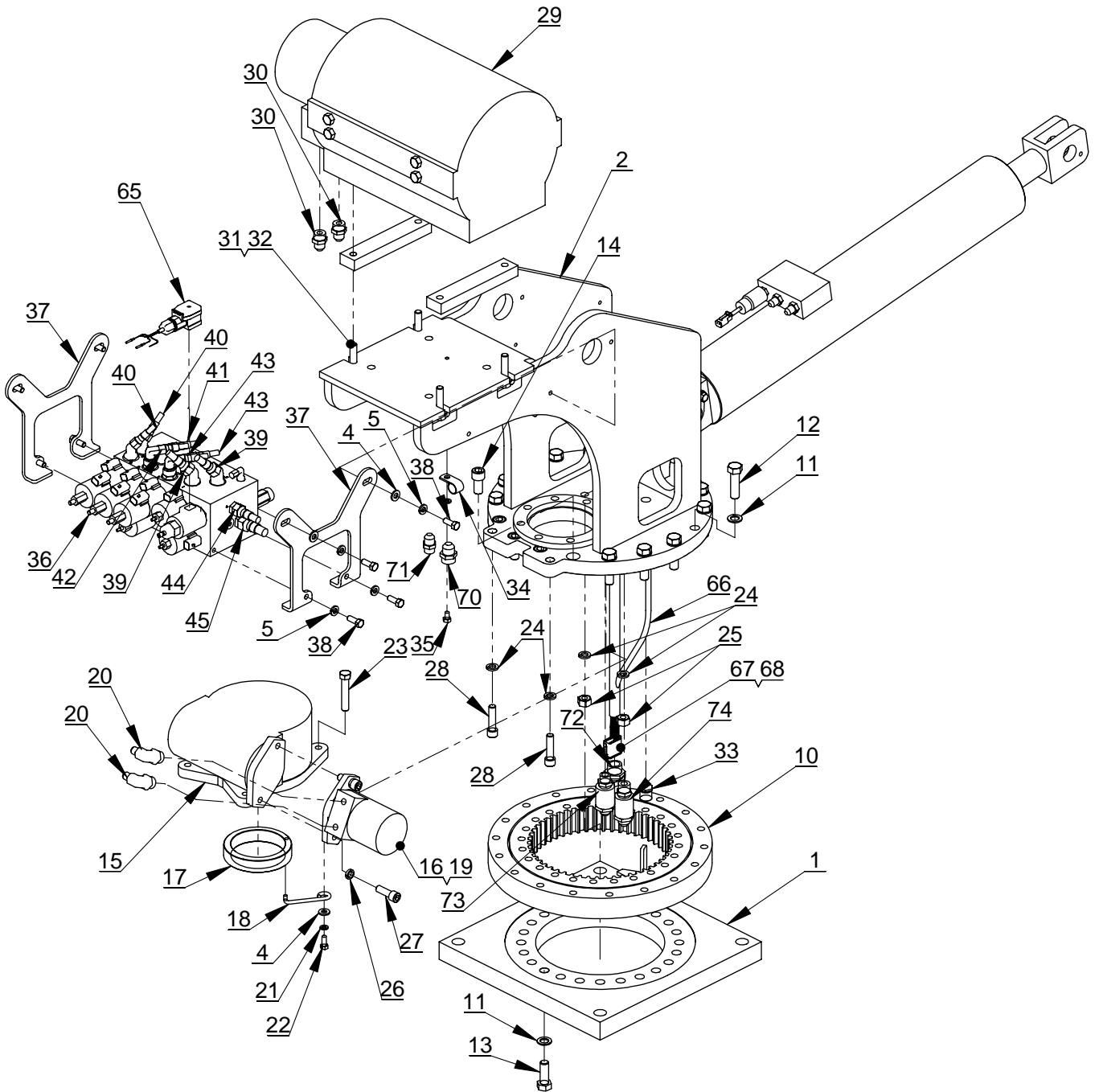

6406H PEDESTAL ASSEMBLY HARDWIRED - P/N: 366740001

ITEM NO.	QTY.	PART NO.	DESCRIPTION
1	1	366721000	BASE PLATE WELDMENT
2	1	366741000	PEDESTAL WELDMENT
3	1	366652000	CYLINDER, LIFT
4	6	320976000	WASHER, FLAT, 3/8 SAE HARDENED
5	9	021100000	WASHER SPLK 3/8
6	1	008702000	SCW HX 3/8-16 X 1 1/4 GR5
7	2	200876000	FITTING 6 SAE/6 JIC STRAIGHT
8	1	366333000	BEARING, SPHERICAL 1.25 ID
9	1	239300000	ZERK, GREASE
10	1	480023002	BEARING, ROTATION
11	38	023902000	WASHER, 5/8 FLAT HARDENED
12	14	490171000	CAPSCREW 5/8-11 X 2.25 GR8
13	24	012198000	CAPSCREW 5/8-11 X 1.75 GR8
14	4	006205000	SOC HD 5/8 X 1 1/4
15	1	160407	GEAR BOX, ROTATION
16	1	366440000	ROTATION MOTOR
17	1	360162000	RING, ECCENTRIC
18	1	360207000	RETAINER ECCENTRIC RING
19	1	480011000	SEAL ROTATION BOX
20	2	490198000	FITTING 10SAE(M)/6JIC ELBOW 90
21	4	020601000	WASHER 5/16 LOCK
22	1	007807000	SCW HEX 5/16-18 3/4LG GR5
23	2	011202000	SCW HX HD 1/2-20 X 2 3/4 GR5
24	8	021500000	WASHER SP LK 1/2
25	2	017704000	NUT HX HVY 1/2 NF
26	2	021502000	WASHER SP/LK 1/2 HI COLLAR
27	2	012197000	SOC HD 1/2-13 X 1-1/2
28	2	009118000	SOC HD 1/2 UNC X 2
29	1	123314	HOIST RPH3000
30	2	372041000	FITTING 8JIC/10SAE STRAIGHT 8-10 F5OX
31	4	320588000	WASHER FL 1/2
32	4	366391000	HEX HD 1/2-13 X 2 1/4
33	1	642908000	CORD CONNECTOR
34	1	480024000	MOUNT PENDANT CABLE RETAINER
35	1	007401000	SCW 5/16-18 X 1/2 LG
36	1	366760000	VALVE, CONTROL 4 FUNC W/ PROP UNLOAD
37	2	366364000	PLATE, VALVE MOUNTING
38	8	330371000	SCW HX 3/8 UNC X 1 GR8
39	2	480202000	HOSE ASSY 8 STR X 21.5
40	2	812209022	HOSE ASSY 6 STR/90

6406H PEDESTAL ASSEMBLY HARDWIRED - P/N: 366740001

ITEM NO.	QTY.	PART NO.	DESCRIPTION
41	1	812203028	HOSE ASSY 6 STR
42	1	812203030	HOSE ASSY 6 STR
43	2	480205000	HOSE ASSY 6 STR X 19.25
44	1	812309024	HOSE ASSY 8 STR/90
45	1	812409022	HOSE ASSY 10 STR/90
46	1	366676000	COVER, ROTATION STOP
47	1	460079000	BEARING, ROTATION STOP
48	2	020901000	WASHER FL 5/16
49	1	366671000	ARM, ROTATION STOP
50	4	460093000	SCW #10-24 X 1 ZP
51	4	020000000	10 SAE FLAT WASHER
52	4	015801000	NUT, #10-24 NYLON LOCK ZP
53	1	366685000	PLATE, BOOM LIMIT SWITCH
54	1	366675000	WASHER, NYLON
55	1	366673000	PIN, ROTATION STOP
56	1	366672000	BRACKET, ROTATION STOP
57	2	017301000	NUT HX NYLON LOCK 3/8 NCCP
58	2	330252000	SCW HX 5/16 NC X 3/4 GR5
59	2	002607000	SCW, #10-24 X 3/4 ZP
60	1	360676000	PIN, CYLINDER
61	1	360678000	PIN, 3/16 COTTERLESS RING
62	1	460111000	BOOM LIMIT SWITCH ASSEMBLY
63	1	460110000	ROTATION STOP SWITCH ASSEMBLY
64	48	374086000	NYLON HOSE SLEEVE
65	1	366363002	AMP MODIFICATION, CONNECTORS
66	1	460120001	MAIN HARNESS ASSEMBLY, HARD WIRED
67	1	366522001	HOUSING, PLUG, DEUTSCH 12-PIN
68	1	366522002	WEDGE, DEUTSCH PLUG, 12 SOCKET
69	1	480880000	LOAD SENSOR SWITCH, 2500 PSI
70	1	490199000	FITTING STR 10-SAE/10-JIC
71	1	367145000	FITTING STR 8-SAE/8-JIC
72	1	370433000	CORD CONNECTOR HUBBLE F-3
73	1	366359000	FITTING 8 SAE/JIC SWIVEL PS810503-8-8
74	1	366358000	FITTING 10SAE/JIC SWIVEL PS810503-10-10
75	1	320355000	RELAY, BOSCH
76	1	006200000	SCW HX HED 1/4-20 X 1-1/4
77	1	020300000	WASHER FL SAE 1/4
78	1	020200000	WASHER SPLIT LOCK 1/4
79	1	015900000	NUT 1/4 NC

6406H BOOM ASSEMBLY

P/N: 366630000

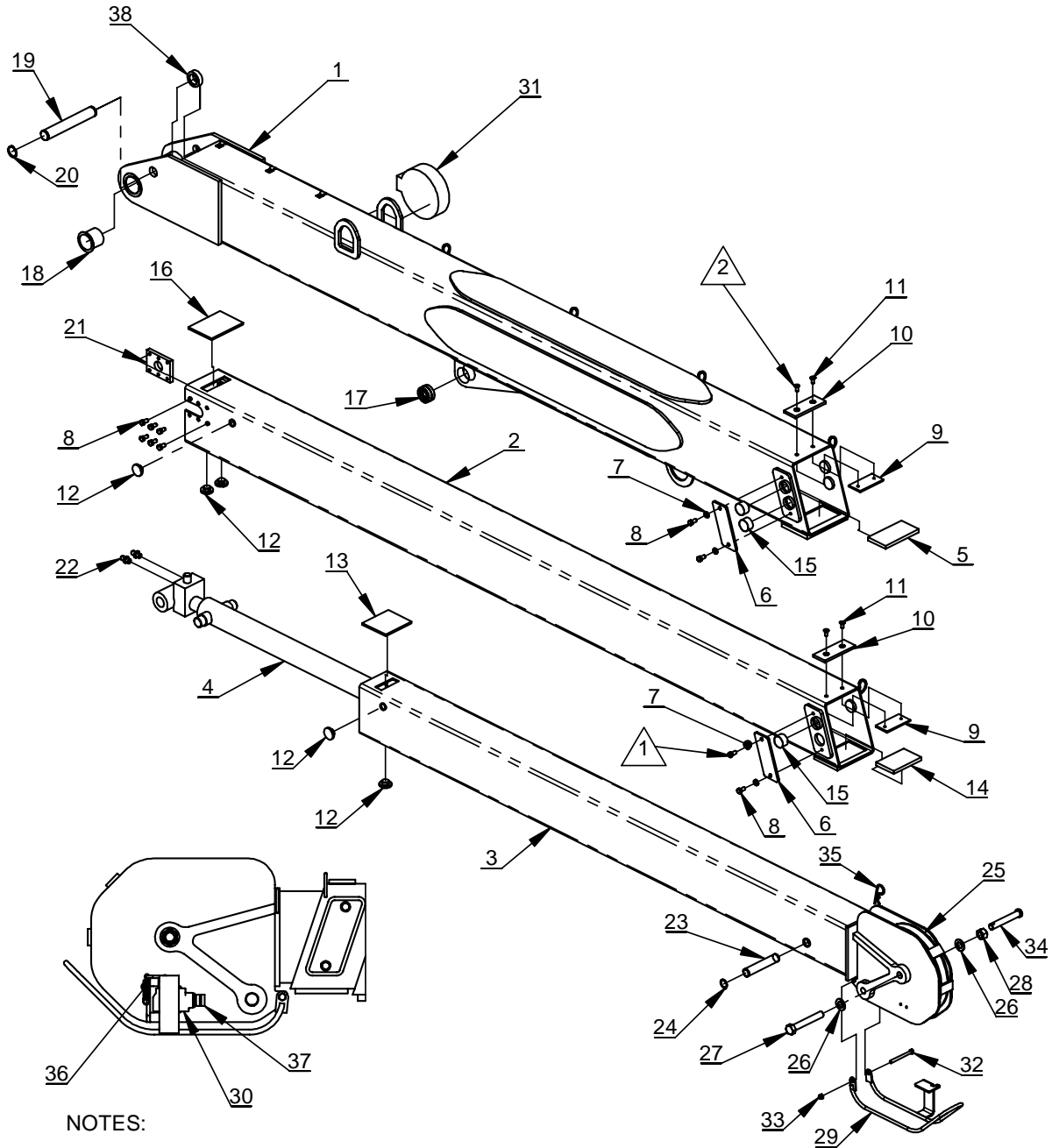

NOTES:

- ① APPLY LOCTITE 609 TO BOLT THREADS, 12 PLCS BEFORE INSTALLING.
- ② APPLY LOCTITE 242 TO BOLT THREADS, 4 PLCS BEFORE INSTALLING.

CYL SEAL KIT P/N: 366331001
 C'BAL P/N: 360153001

6406H BOOM ASSEMBLY

P/N: 366630000

ITEM NO.	QTY.	PART NO.	DESCRIPTION
1	1	366631000	LOWER BOOM WELDMENT
2	1	366632000	MID BOOM WELDMENT
3	1	366633000	UPPER BOOM WELDMENT
4	1	366331000	CYLINDER EXTENSION
5	1	366669000	WEAR PAD, BOTTOM MID
6	4	366696000	COVER, SIDE WEAR PAD
7	8	021100000	WASHER SP LK 3/8
8	20	008400000	SCREW HX HD 3/8-16UNC X 3/4 LG GR 5
9	2	460082000	PLATE, WEAR PAD RETAINER
10	2	460081000	WEAR PAD, CABLE
11	4	460083000	SCREW SOC HD CTRS NK 5/16-24UNF X 3/4 LG
12	7	360767000	PAD BOOM 1.5 O.D.
13	1	366647000	WEAR PAD, TOP UPPER
14	1	366648000	WEAR PAD, BOTTOM UPPER
15	6	366666000	WEAR PAD, SIDE
16	1	366667000	WEAR PAD, TOP MID
17	1	366333000	BEARING, SPHERICAL 1.25 ID
18	2	366394000	BEARING, PIVOT
19	1	366400000	PIN 1.25<MOD-DIAM> X 8.063
20	2	480029000	RING RETAINING
21	2	366184000	RETAINER EXTENSION CYLINDER
22	2	200876000	FITTING 6 SAE/6 JIC STRAIGHT
23	1	366493000	PIN 1<MOD-DIAM> X 5.03 LG
24	2	738734000	RING RETAINING 5100-100
25	1	366198000	SHEAVE ASSY 3/8
26	2	022102000	WASHER FL 3/4
27	1	014400000	SCREW HX HD 3/4-16UNF X 5 LG GR5
28	1	018600000	NUT HX NYLK 3/4-16UNF CP
29	1	360718000	BAIL WELDMENT
30	1	646900000	SWITCH, LIMIT ANTI-TWO BLOCK
31	1	360759000	CORD REEL ASSY
32	1	007803000	SCREW HX HD 5/16-18UNC X 3-1/2 LG GR5
33	1	016801000	NUT HX NYLK 5/16-18UNC CP
34	1	360125000	PIN, BLOCK
35	1	360124000	PIN HITCH
36	1	366678000	SPRING, EXTENSION
37	1	366694000	CORD GRIP .1875-.25 1/2 HUB
38	2	366706000	SPACER, EXTENSION CYLINDER

6406H ROTATION GEARBOX P/N: 160407

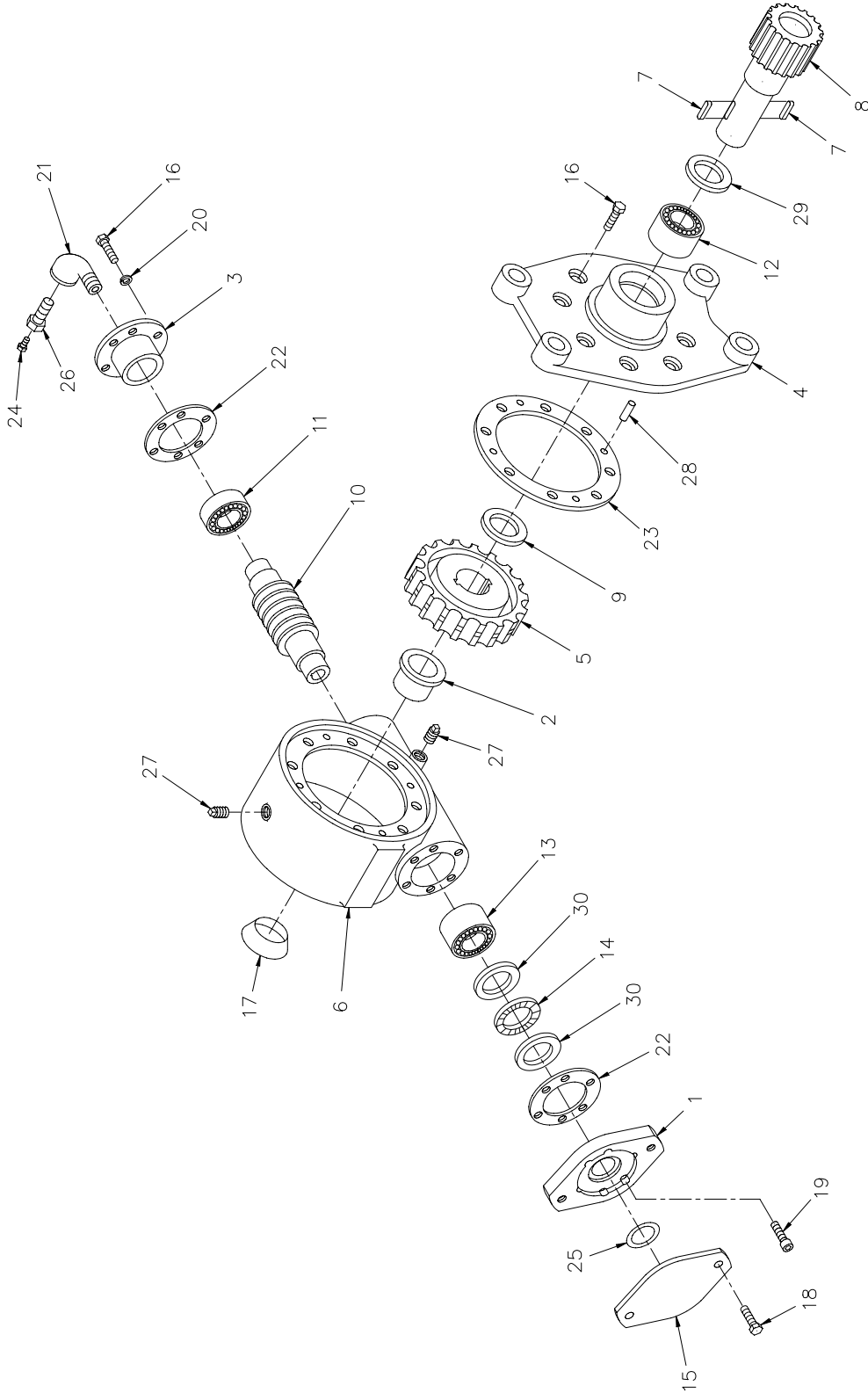

6406H ROTATION GEARBOX

P/N: 160407

ITEM NO.	QTY.	PART NO.	DESCRIPTION
1	1	300058	ADAPTER
2	1	308085	BUSHING
3	1	316092	CAP BEARING
4	1	328126	COVER
5	1	334016	GEAR R.H.
6	1	338261	HOUSING GEAR
7	2	342120	KEY
8	1	357139	SHAFT OUTPUT
9	1	366019	WASHER THRUST
10	1	368183	WORM R.H.
11	1	402044	BEARING BALL
12	1	402105	BEARING NEEDLE
13	1	402106	BEARING NEEDLE
14	1	402107	BEARING THRUST
15	1	413013	COVER
16	14	414146	SCREW HX HD 5/16 NC X 1 1/4 GR5 (NYLON HEAVY PATCH)
17	1	530101	PLUG - EXPANSION
18	2	414581	SCREW HX HD 1/2 NC X 3/4 GR5
19	6	414869	SCREW SOC HD 5/16 NC X 1
20	6	418163	WASHER LK 5/16 MED SECT
21	1	432011	ELL 90 DEG
22	2	442182	GASKET
23	1	442187	GASKET
24	1	456008	FITTING RELIEF
25	1	462029	O-RING
26	1	468002	REDUCER
27	2	468018	PLUG PIPE
28	4	470062	PIN DOWEL
29	1	486071	SEAL OIL
30	2	518026	WASHER THRUST

6406H HOIST ASSEMBLY

P/N: 123314

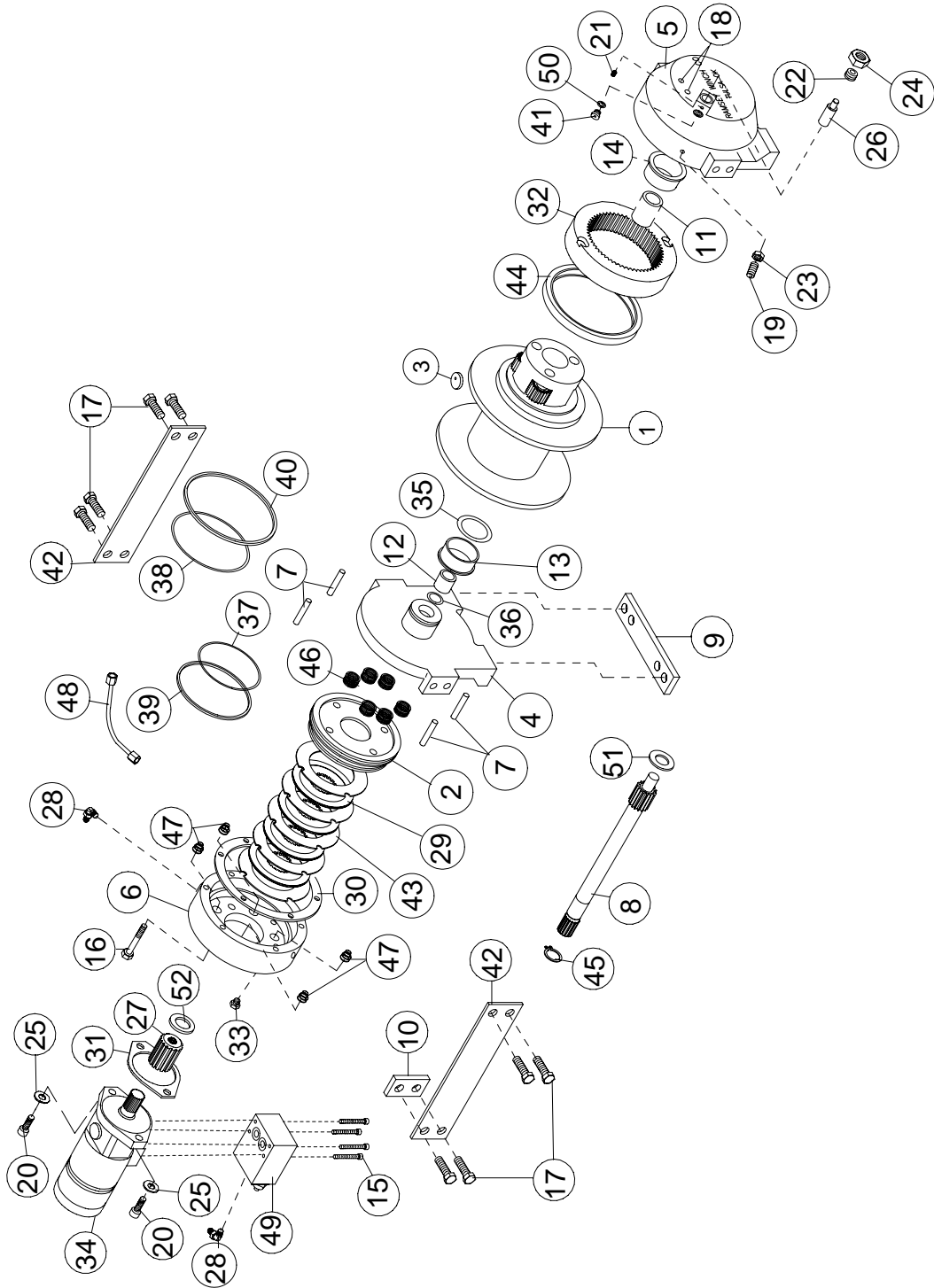

SEAL KIT #246048

6406H HOIST ASSEMBLY

P/N: 123314

ITEM	QTY	PART NO.	DESCRIPTION
1	1	234189	DRUM ASSEMBLY
2	1	306042	PISTON-BRAKE
3	1	315004	ANCHOR- CABLE
4	1	338300	END BRG-MOTOR END
5	1	338301	END BRG-GEAR HSG.
6	1	338302	HSG-BRAKE
7	4	346045	PIN-BRAKE
8	1	357513	SHAFT- INPUT
9	2	357513	SPACER - FOOT MTG
10	4	362284	SPACER - TIE PLATE
11	1	402120	BEARING-GARLOK BRG.#12U16 OR EQUIV.
12	1	402121	BEARING-RPH12,GARLOCK BRG#16DU08/EQ
13	1	412084	BUSHING-DRUM,MOTOR END
14	1	412085	BUSHING-DRUM,GEAR END
15	4	414129	CAPSCREW 5/16-18NCX3 LG HX HD GR-5
16	6	414303	BOLT-3/8-16NC X2 1/2,HXHD,GR-5, Z/P
17	8	414548	CAPSCREW-1/2-13NCX1 1/2,HXHD,Z/P,G5
18	2	414854	SCREW-1/4-20NCX1/2LG,RDHD,SLOT,Z/PL
19	1	414926	SETSCREW-3/8-16NC X1,SOCKET,NYLON
20	2	414948	CAPSCREW-1/2-13NCX1 1/4LG,SOCKET HD
21	1	416016	SETSCREW1/4-20NCX1/4 HX SOCK HD CUP
22	1	416080	SETSCREW-5/8-18NF X1 LG,HXSOCHD,CUP
23	1	418036	NUT-3/8-16 NC,HEX JAM,Z/P
24	1	418088	NUT-JAM 5/8-18NF HEX HD,ZINC PLT
25	2	418218	LOCKWASHER-1/2 ID MED SECT,ZINC PLT
26	1	426048	PLUNGER-CLUTCH,BLOCKED,RPH12/15000
27	1	431015	COUPLING-MOTOR,P/M, RPH-12000
28	2	432018	FITTING #4-C5OX-S T-LOK, 7/16-20 90 degree
29	4	438022	DISC-BRAKE
30	1	442220	GASKET-BRAKE HSG.,RPH12000,#VCN-60
31	1	442223	GASKET-MOTOR FLANGE,RPH12000
32	1	444085	GEAR-RING,P/M,RPH-12000
33	1	456038	FITTING-VENT,BREATHER,#ASP-1BV/EQIV
34	1	458119	MOTOR-HYDRAULIC, W/COUNTERBALANCE
35	1	462046	O-RING 1/8X2 1/4 OD X 2, AS-568-226
36	1	462056	O-RING-AS-568-214
37	1	462057	O-RING-AS-568-256
38	1	462058	O-RING-AS-568-259
39	1	462059	RING-BACK-UP,VERCO #1750-256
40	1	462060	RING-BACK-UP,VERCO #1750-259

6406H HOIST ASSEMBLY

P/N: 123314

ITEM	QTY	PART NO.	DESCRIPTION
41	1	472052	PLUG-SAE O-RING,.562-18NF,HXSOC
42	2	474065	TIE PLT-7GAX2.25X10.25,W/Y-DM,IPH8Y
43	5	474111	PLATE-SEPARATOR,BRAKE,RPH-12000
44	1	486080	SEAL-GH,MIKRON #RWH-675,MB-2590,RPH
45	1	490037	SNAP RING-TRUARC #5100-93,OR EQUIV.
46	6	494110	SPRING-BRAKE,ASSOC#CV1000-1000-158
47	4	494112	SPRING-RPH12000,PRESSURE TO BRAKE
48	1	509009	TUBE ASSY-1/4OD,HYD.BRK.,RPH-12000
49	1	516033	VALVE-MOTOR CONTROL 4.5:1 RATIO
50	1	518037	THRUST WASHER-TORRINGTON #TRA-1018
51	1	518047	THRUST WASHER,0.063 THK.X1.50 OD
52	1	518052	THRUST WASHER,1.37 O.D.,RPH-12000

6406H TRAVELING BLOCK ASSEMBLY

P/N: 366398000

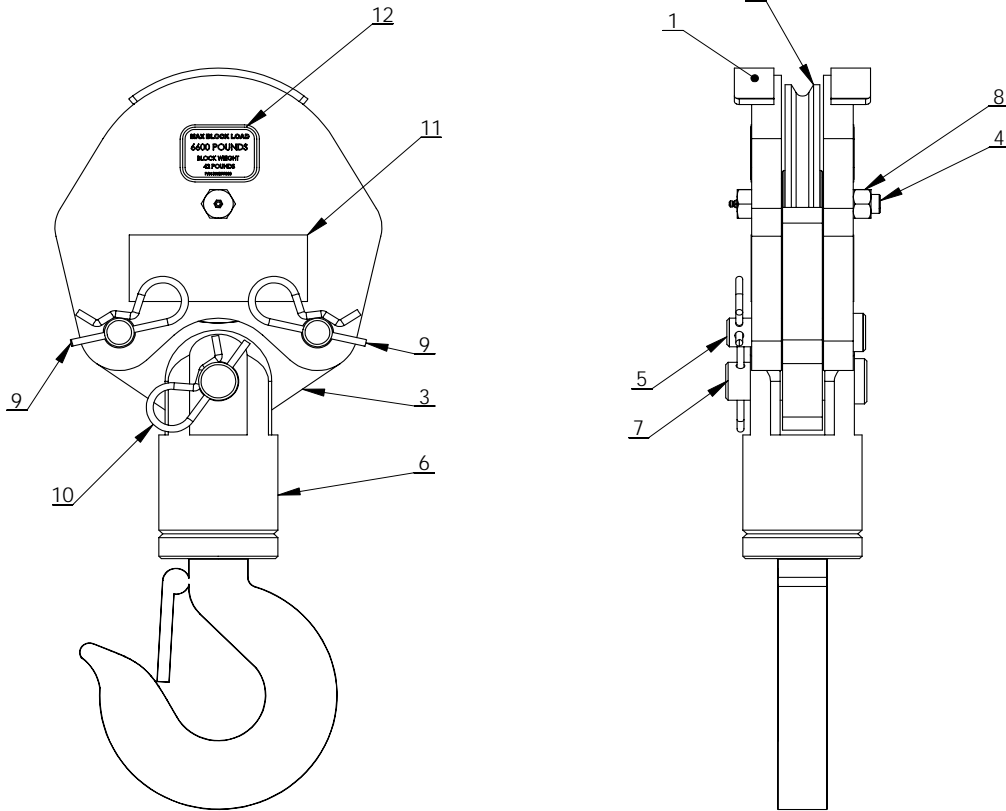

ITEM NO.	QTY.	PART NO.	DESCRIPTION
1	2	480362000	SHORT BLOCK SIDE PL WDMT
2	1	480130000	SHEAVE ASSY
3	1	480364000	TACKLE LOWER
4	1	480372000	BOLT, SHEAVE W/ ZERK FITTING
5	2	480367000	PIN BLOCK
6	1	480371000	HOOK SWIVEL 3 METRIC TON
7	1	480368000	PIN SWIVEL HOOK
8	1	017800000	NUT, HEX-LOCK 1/2-20 NF
9	2	366813000	PIN HITCH
10	1	360124000	PIN HITCH
11	2	040518000	DECAL STAY CLEAR OF LOAD
12	2	366399000	DECAL MAX BLOCK LOAD 6406H

6406H ELECTRICAL SCHEMATIC

HARDWIRED - P/N: 366372000

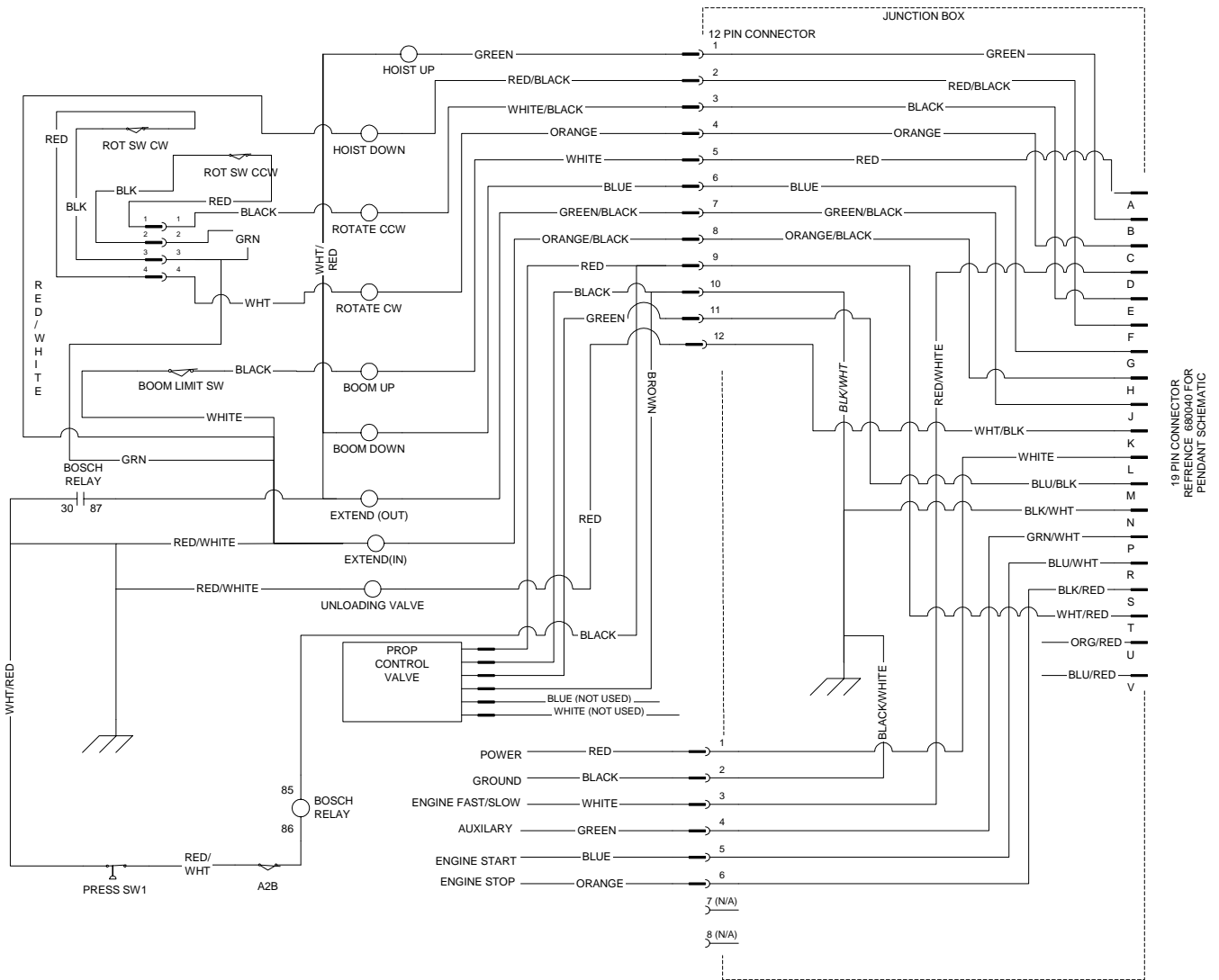

6406H MAIN WIRING HARNESS HARDWIRED - P/N: 460120001

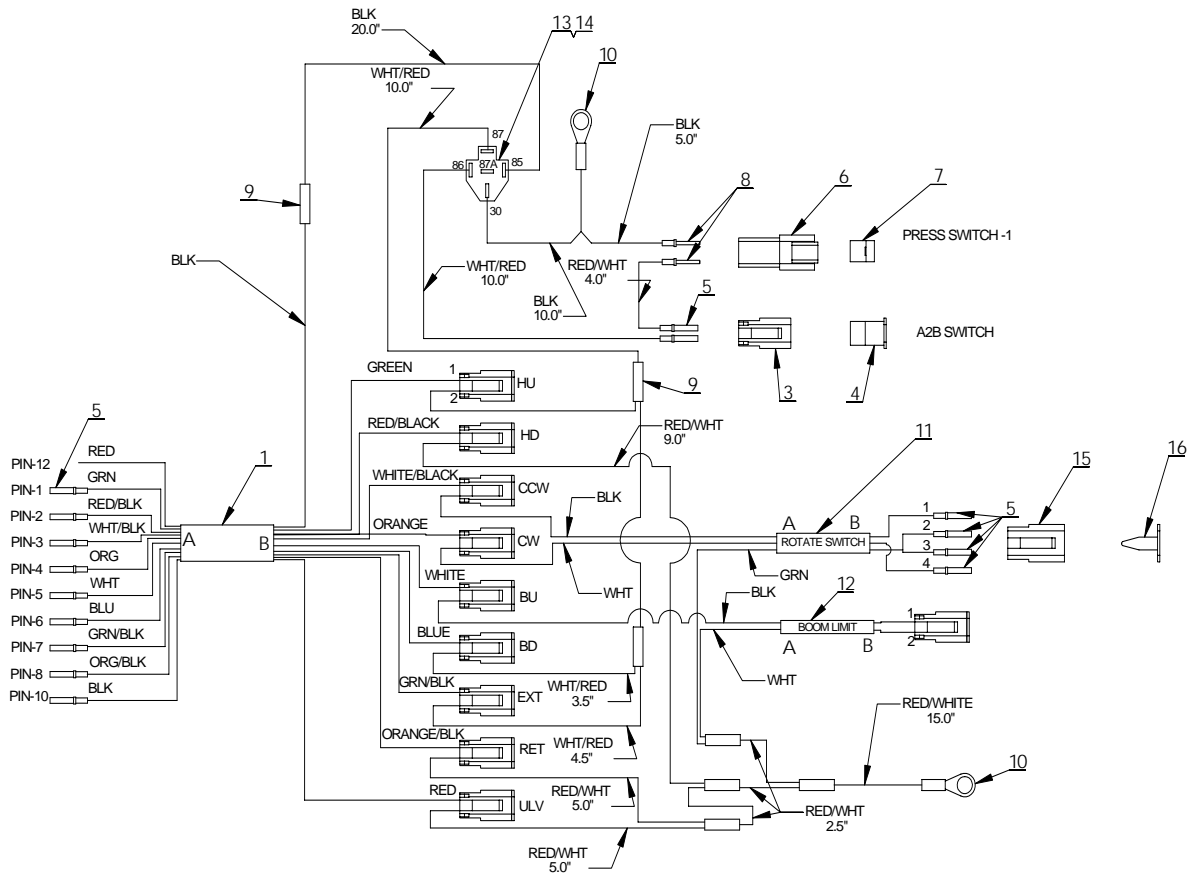

ITEM NO.	QTY	PART NUMBER	DESCRIPTION
1	1	800632000	CABLE, 16/10 SO BLACK
2	9	366367000	DEUTSCH 2 PIN Assembly
3	2	366367001	HOUSING, DEUTSCH 2-PIN PLUG
4	2	366367002	WEDGE, DEUTSCH PLUG, 2 PIN
5	17	366367003	CONTACT, DEUTSCH SOCKET
6	1	360769001	HOUSING, DEUTSCH 2-PIN RECEPTACLE
7	1	360769002	WEDGE, DEUTCH 2-PIN RECEPTACLE
8	2	366376003	CONTACT, DEUTSCH
9	7	1104000	TERMINAL SPLICE 14-16 GA
10	2	501000	TERMINAL RING, 5/16, 14-16 GA
11	1	800628000	WIRE, 3 CONDUCTOR
12	1	800626000	WIRE, 2 CONDUCTOR
13	1	320363	PLUG TERMINAL CONNECTOR
14	4	320357	FEMALE SPADE, NON-INSULATED
15	1	320931001	HOUSING, DEUTSCH 4-PIN PLUG
16	1	320931002	WEDGE, 4-PIN DEUTSCH PLUG

FUNCTION	PIN	WIRE COLOR	NOTES
HOIST UP	1	GREEN	POWER
	2	WHITE/RED	TO A2B GROUND
HOIST DN	1	RED/BLACK	POWER
	2	RED/WHITE	GROUND
ROTATE CCW	1	WHITE/BLACK	POWER
	2	BLACK	TO CCW SWITCH (3 COND CABLE)
ROTATE CW	1	ORANGE	POWER
	2	WHITE	TO CW SWITCH (3 COND CABLE)
BOOM UP	1	WHITE	POWER
	2	BLACK	BOOM SWITCH CABLE
BOOM DN	1	BLUE	POWER
	2	WHITE/RED	TO A2B GROUND
EXTEND	1	GREEN/BLACK	POWER
	2	WHITE/RED	TO A2B GROUND
RETRACT	1	ORANGE/BLACK	POWER
	2	RED/WHITE	GROUND
A2B SWITCH	1	RED/WHITE	TO PIN 2, PRESSURE SWITCH
	2	WHITE/RED	FROM BOSCH RELAY PIN 86
PRESSURE SWITCH	1	BLACK	GROUND
	2	WHITE/RED	FROM A2B PIN 1
ROTATE SWITCH	1	BLACK	*PIN 2 ON ROTATE CCW PLUG
	4	WHITE	**PIN 2 ON ROTATE CW PLUG
3 COND CABLE	2,3	GREEN	GROUND
	2	WHITE	GROUND
BOOM LIMIT 2 COND CABLE	1	BLACK	***PIN 2 ON BOOM UP PLUG
	1	RED	POWER
UNLOADING VALVE	1	RED	POWER
	2	RED/WHITE	GROUND

6406H JUNCTION BOX ASSEMBLY HARDWIRED - P/N: 366520002

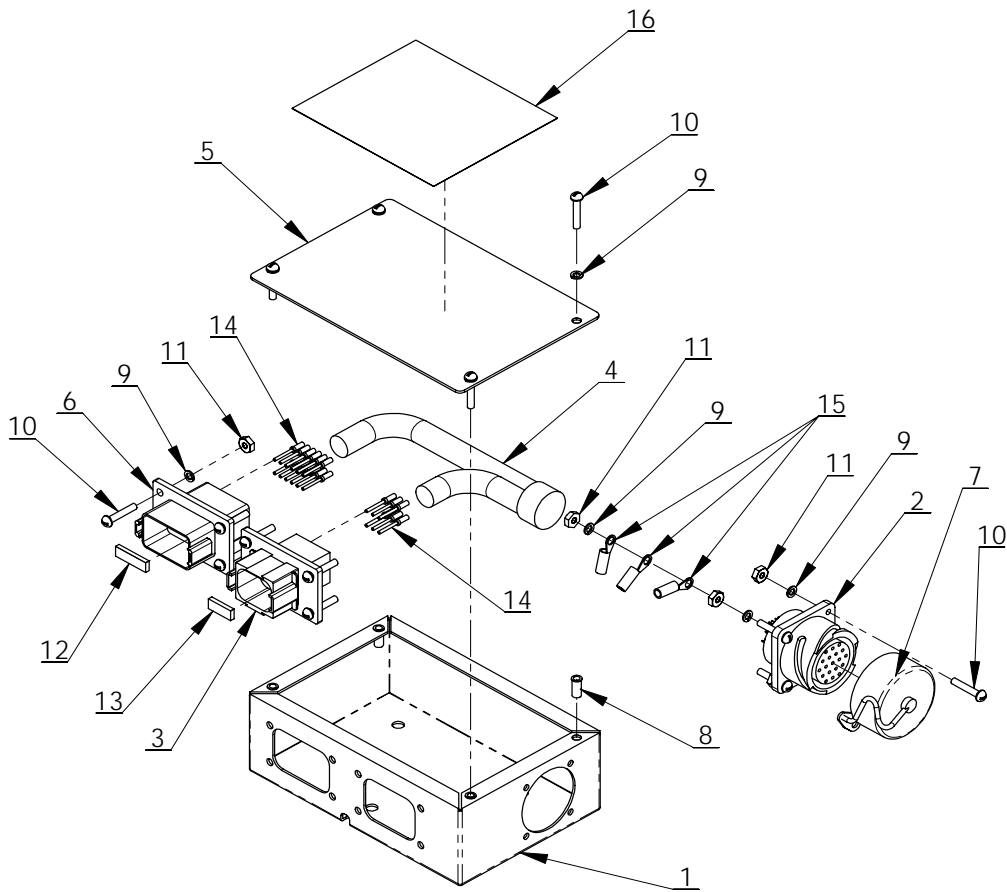

19 PIN	8 PIN	12 PIN	GND	WIRE COLOR	WIRE CUT LENGTH
A		5		RED	6.5
B		1		GREEN	6.5
C		4		ORANGE	6.5
D	3			RED/WHITE	4.0
E		3		BLACK	6.5
F		2		RED/BLACK	6.5
G		6		BLUE	6.5
H		8		ORANGE/BLACK	6.5
J		7		GREEN/BLACK	6.5
K	-	12		WHITE/BLACK	6.5
L	1			WHITE	4.0
M		11		BLUE/BLACK	6.5
N			GND	BLACK/WHITE	5.5
P	4			GREEN/WHITE	4.0
R	5			BLUE/WHITE	4.0
S	6			BLACK/RED	4.0
T		9		WHITE/RED	6.5
U	-	-		NOT USED	N/A
V	-	-		NOT USED	N/A
		10	GND	BLACK/WHITE	3.0
	2		GND	BLACK/WHITE	5.0

6406H JUNCTION BOX ASSEMBLY HARDWIRED - P/N: 366520002

ITEM NO.	QTY.	PART NO.	DESCRIPTION
1	1	366470000	JUNCTION BOX
2	1	366095000	PLUG, 19 PIN
3	1	366523001	HOUSING, DEUTSCH 8-PIN RECEPTACLE
4	1	480594001	CABLE, PENDANT, 16/10 SO BLACK
5	1	366471000	COVER, JUNCTION BOX
6	1	366524001	HOUSING, DEUTSCH 12-PIN RECEPTACLE
7	1	366097000	CAP W/CHAIN (FOR RECEPTACLE)
8	4	366517000	RIVET NUT, 6-32
9	17	019600000	WASHER SP LK #6
10	16	001004000	SCREW PN HD #6 X 3/4 LG
11	13	015400000	NUT HX #6-32
12	1	366524002	WEDGE, DEUTSCH RECEPTACLE, 12 PIN
13	1	366523002	WEDGE, DEUTSCH RECEPTACLE, 8 PIN
14	18	366376003	CONTACT, DEUTSCH
15	3	000101000	TERMINAL RING, 5/32, 14-16 GA
16	1	366469001	DECAL

6406H PENDANT ASSEMBLY HARDWIRED - P/N: 680040000

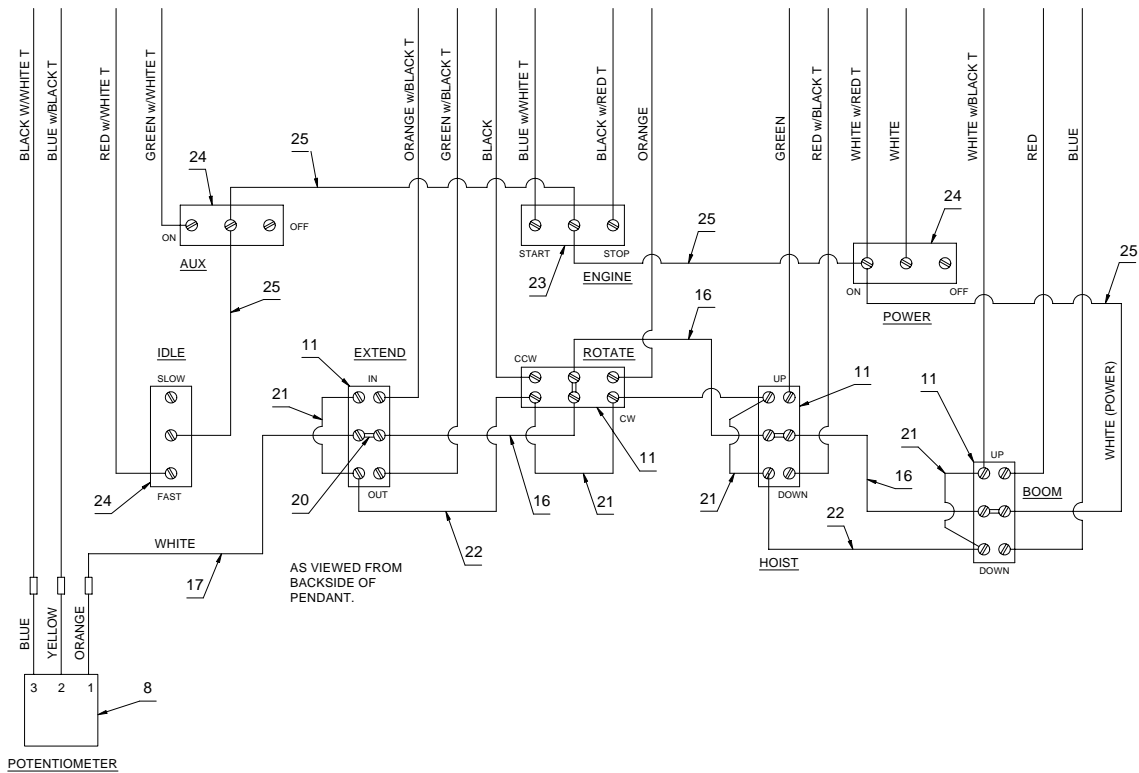
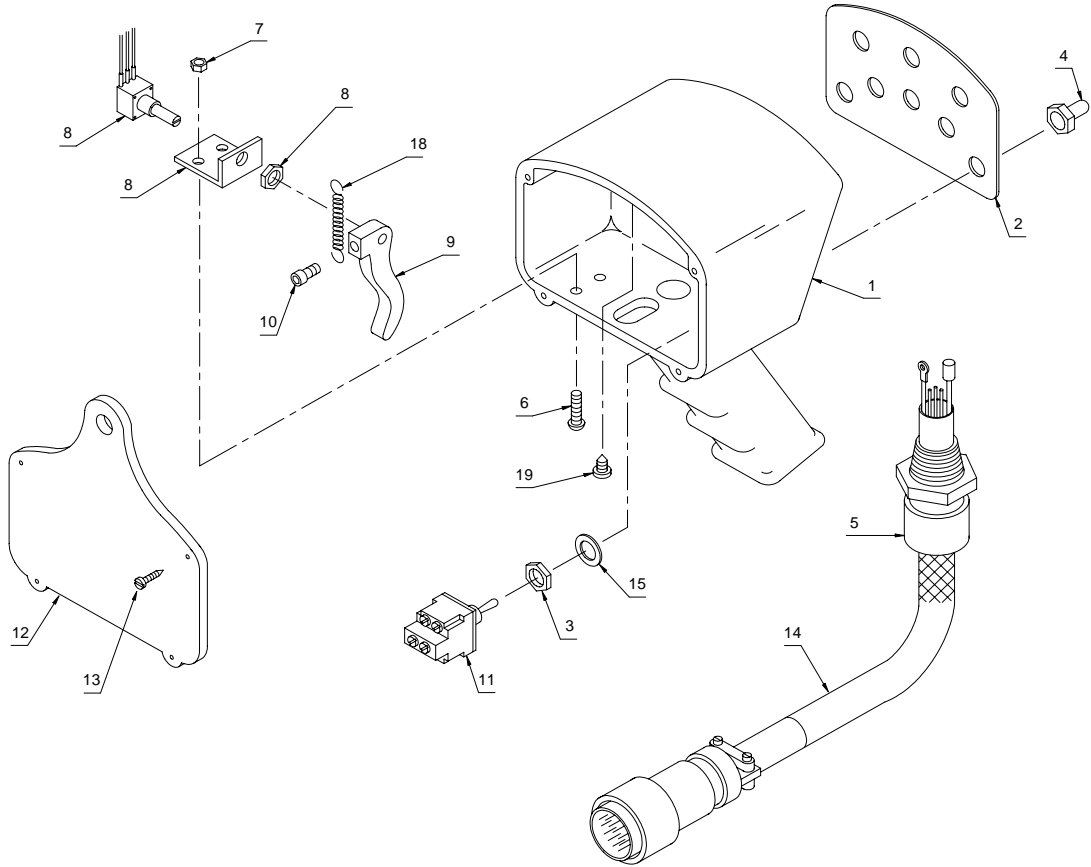

6406H PENDANT ASSEMBLY HARDWIRED - P/N: 680040000

ITEM	QTY	PART NO.	DESCRIPTION
1	1	480501000	HOUSING, PROP. PENDANT MACHINED
2	1	480518000	DECAL/COVER PLATE
3	8	REF	NUT (INCLUDED WITH SWITCH)
4	8	640300000	BOOT, TOGGLE
5	1	480567000	CORD GRIP, HUBBELL CONNECTOR
6	2	002607000	SCREW, HX HD #10-24 NC X 3/4 LG
7	2	015801000	NUT, HEX, LOCKING, #10-24 NC
8	1	480507000	POTENTIOMETER ASSEMBLY
9	1	480506000	TRIGGER
10	1	480517000	SCREW, SOC HD, #10-32 NF X 5/8 LG
11	4	634200000	SWITCH, TOGGLE DPDT
12	1	480504000	BACK PLATE, HOUSING
13	4	001004000	SCREW, PAN HD, #6-32 X 3/4 LG
14	1	680113000	CABLE ASSEMBLY, BAYONET
15	8	REF	WASHER, LOCK (INCLUDED WITH SWITCH)
16	3	660302000	CONDUCTOR ASSEMBLY
17	1	480524000	CONDUCTOR ASSEMBLY
18	1	480523000	SPRING, TRIGGER RETURN
19	1	005003000	SCREW, S.T. PAN HD, #6-32 X 3/8 LG
20	4	636600000	JUMPER
21	4	622346000	CONDUCTOR ASSEMBLY
22	3	622347000	CONDUCTOR ASSEMBLY
23	1	622000000	SWITCH, TOGGLE SPDT
24	3	750090000	SWITCH, TOGGLE ON/OFF
25	1	480526000	CONDUCTOR ASSEMBLY
26	2	750737000	TIE, CABLE

6406H PENDANT CABLE ASSEMBLY HARDWIRED - P/N: 680113000

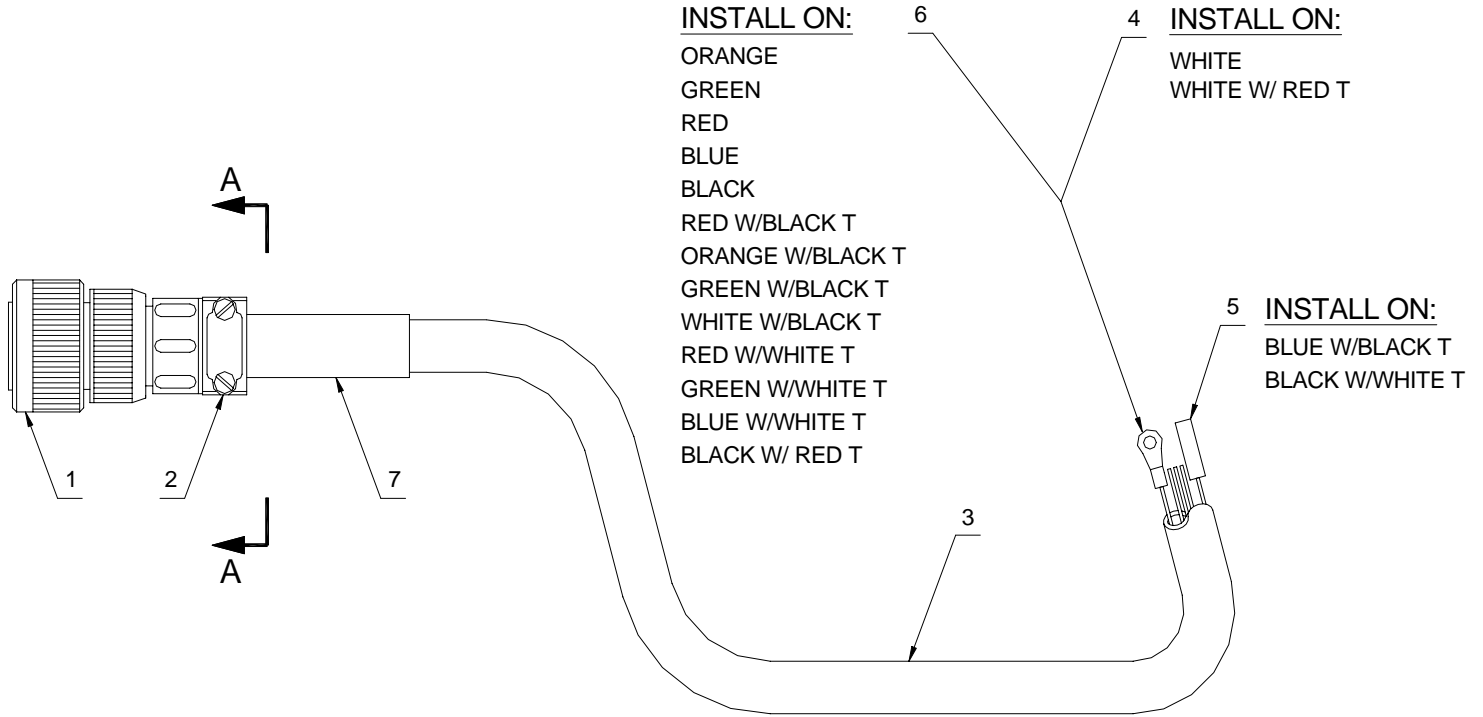

WIRING GUIDE

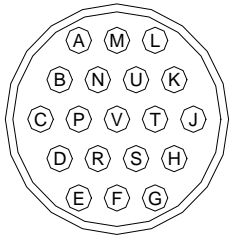

VIEW A-A

- | | |
|---|---|
| <ul style="list-style-type: none"> A-RED B-GREEN C-ORANGE D-RED W/WHITE T E-BLACK F-RED W/BLACK T G-BLUE H-ORANGE W/BLACK T J-GREEN W/BLACK T K-WHITE W/BLACK T | <ul style="list-style-type: none"> L-WHITE M-BLUE W/BLACK T N-BLACK W/WHITE T P-GREEN W/WHITE T R-BLUE W/WHITE T S-BLACK W/RED T T-WHITE W/RED T U-ORANGE W/RED T V-BLUE W/RED T |
|---|---|

ITEM	QTY	PART NO.	DESCRIPTION
1	1	366098000	PLUG, CONNECTOR
2	1	480515000	CLAMP, CABLE
3	30'	480594000	CABLE, CONDUCTOR (19 COND)
4	2	000101000	TERMINAL RING #6 / 14-16 GA
5	2	480510000	CONNECTOR, BULLET, FEMALE
6	13	002012000	TERMINAL RING #6 / 18-22 GA
7	6"	490243000	TUBING, HEAT SHRINK

6406H PROPORTIONAL VALVE CONTROLLER HARDWIRED - P/N: 366363002

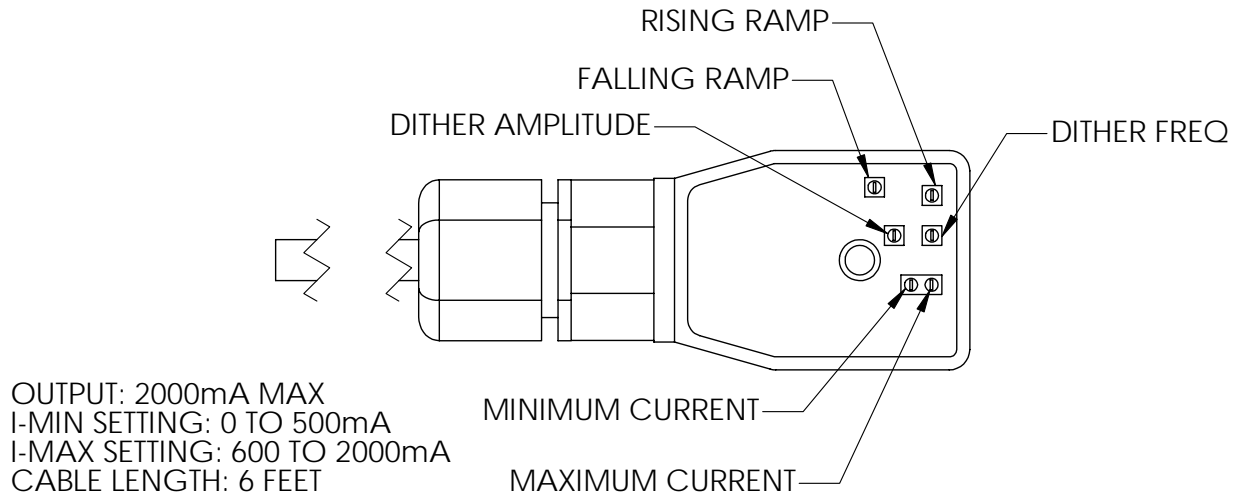

MINIMUM CURRENT ADJUSTMENTS

Current is factory set at 150 mA, no adjustment required at installation. If adjustment is required, set the minimum current before setting the maximum current. Apply minimum input (0 VDC). If the desired minimum current is greater, adjust the trim pot CW until the desired current is achieved.

MAXIMUM CURRENT

Current is factory set at 1600 mA, no adjustment required at installation. If adjustment is required, apply maximum control (5 VDC). Turn the trim pot CCW to adjust the current setting downwards to the desired minimum.

RAMP AND DITHER

Ramp and dither is adjusted at the factory and does not require any further adjustment.

6406H HYDRAULIC SCHEMATIC

P/N: 366366000

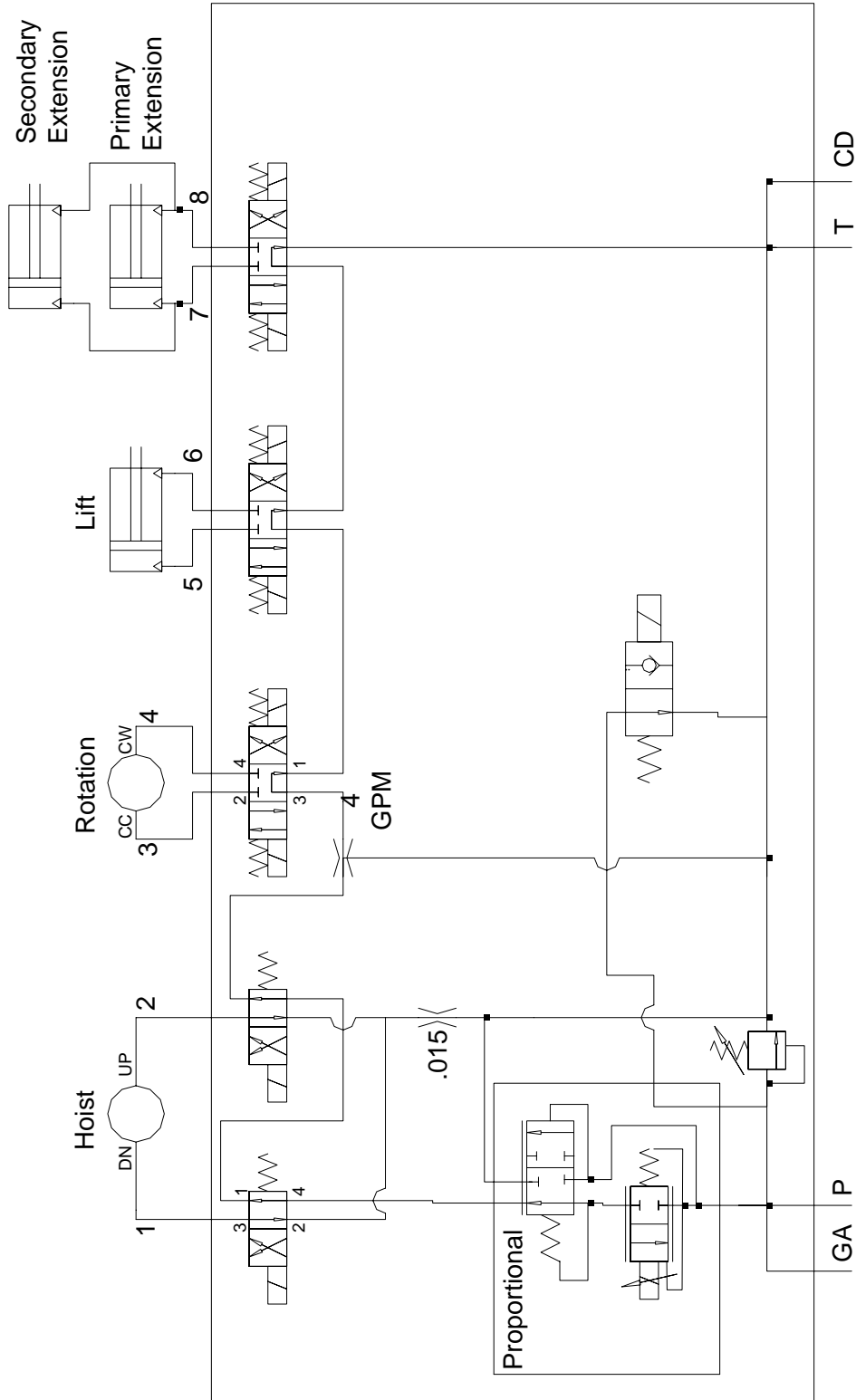

6406H

COUNTERBALANCE VALVE ADJUSTMENT

Counterbalance Valve Adjustment

1. With PTO disengaged and boom properly supported, remove the plug on the counterbalance valve. Install a pressure gauge (0-3000 PSI) into the port.
2. Engage PTO and insure pump flow is 8 to 9 GPM. With no load on boom, boom up to an angle of 70 degrees. Boom down and note pressure. If pressure reading is not approximately 1300 PSI, the counterbalance valve requires adjustment.
 - A. To increase the CB valve setting, loosen nut and turn Allen head screw counter clockwise.
 - B. To reduce the CB valve setting, loosen nut and turn Allen head screw clockwise.
3. Tighten nut on adjustment screw and repeat procedure if needed to obtain the proper pressure setting.
4. Disengage PTO, remove the pressure gauge and install plug. Crane is now ready for operation.

Notice:

1. In an **EMERGENCY** situation when it becomes necessary to lower the boom without flow present, the CB valve adjustment can be turned in until the boom begins to descend. Make sure the boom will lower onto a proper support. Loosen the lock nut and carefully turn adjustment screw clockwise! Count the number of turns. *Turn slowly until the boom just begins to lower, and remove hand/arm/fingers from cranes while boom is lowering.*
2. Turning adjustment screw too far will cause valve to come apart on the inside. This condition is not repairable
3. After boom is lowered, turn adjustment screw counter clockwise the approximate number of turns made during lowering procedure. After the problem is corrected, readjust the counterbalance valve using the procedure in this manual.

WARNING:

**DO NOT TRY TO ADJUST VALVES WHILE BOOM IS MOVING.
Doing so may result in personal injury!**

6406H HYDRAULIC CONTROL VALVE HARDWIRED - P/N: 366760000

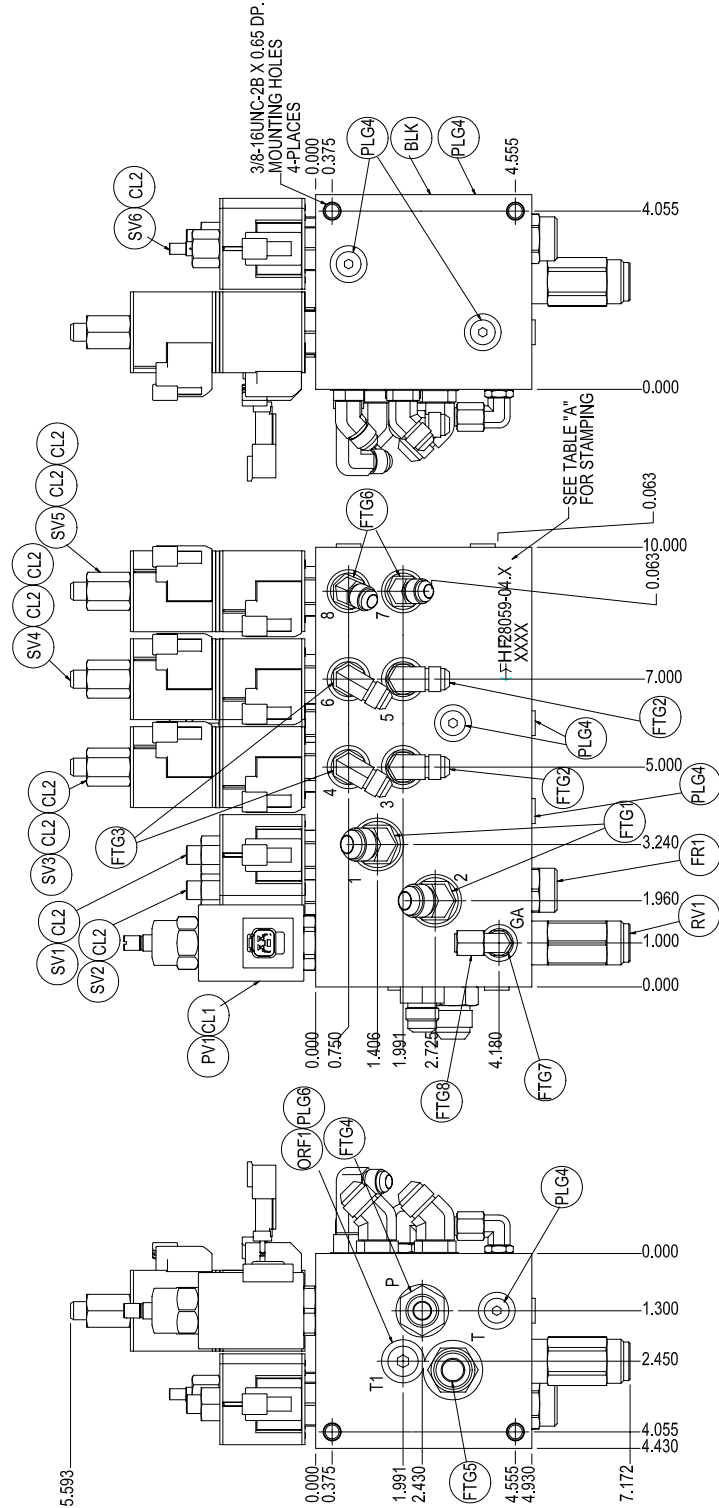

6406H HYDRAULIC CONTROL VALVE HARDWIRED - P/N: 366760000

ITEM NO.	QTY.	PART NO.	DESCRIPTION
PV1	1	366365002	PROP VALVE
CL1	1	320725001	COIL
FR1	1	366365003	FLOW CONTROL
RV1	1	366365004	RELIEF VALVE
SV6	1	366760001	UNLOAD VALVE
SV1,SV2	2	480186000	CART VALVE
SV3,SV4,SV5	3	320725001	CART VALVE
CL2	9	460160002	COIL
ORF1	1		PLUG ORIFICE
FTG1	2	374017000	FITTING 45 8-SAE/8-JIC
FTG2	2	330272000	FITTING
FTG3	2	480194000	FITTING
FTG4	1	367145000	FITTING
FTG5	1	490199000	FITTING STR 10-SAE/10-JIC
FTG6	2	466207000	FITTING
FTG7	1	369127000	FITTING 90 4-SAE/4JIC
FTG8	1	330348000	FITTING CAP 4-JIC
PLG4	7		PORT
PLG6	1		PORT
NOT SHOWN	23		PLUG
BLK	1		BLOCK

NOTES

6406H

VALVE OVERRIDE OPERATION

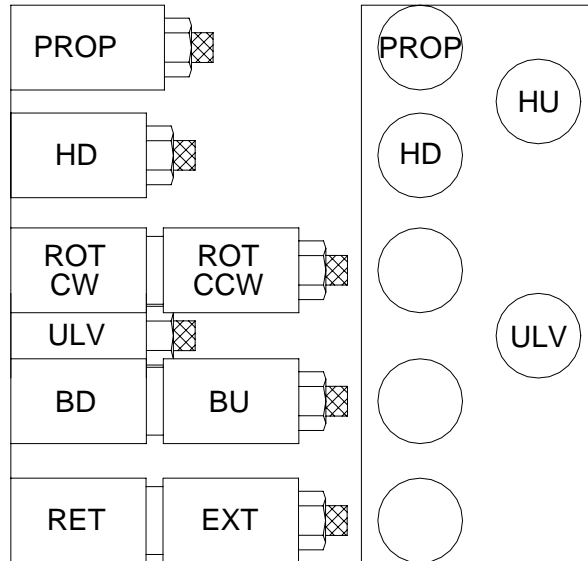

DIRECTIONAL CONTROL VALVE IDENTIFICATION

In the event that the electrical control system fails the crane can be operated using the manual overrides on the hydraulic control valve.

The overrides operate as follows:

1. Proportional – increase flow by turning clockwise.
2. Extend/Retract, Boom Up/Down, Rotate CW/CCW – push to operate boom down, pull to operate boom up etc. See graphics above.
3. Hoist Up/Down, Unload Valve – Push in to operate.

Note: To manually activate a function the crane with no electrical power, you must first turn manual override on proportional clockwise then push in the unload valve while pushing or pulling the function you want to activate.

6406H GENERAL ASSEMBLY

FM - P/N: 366720000

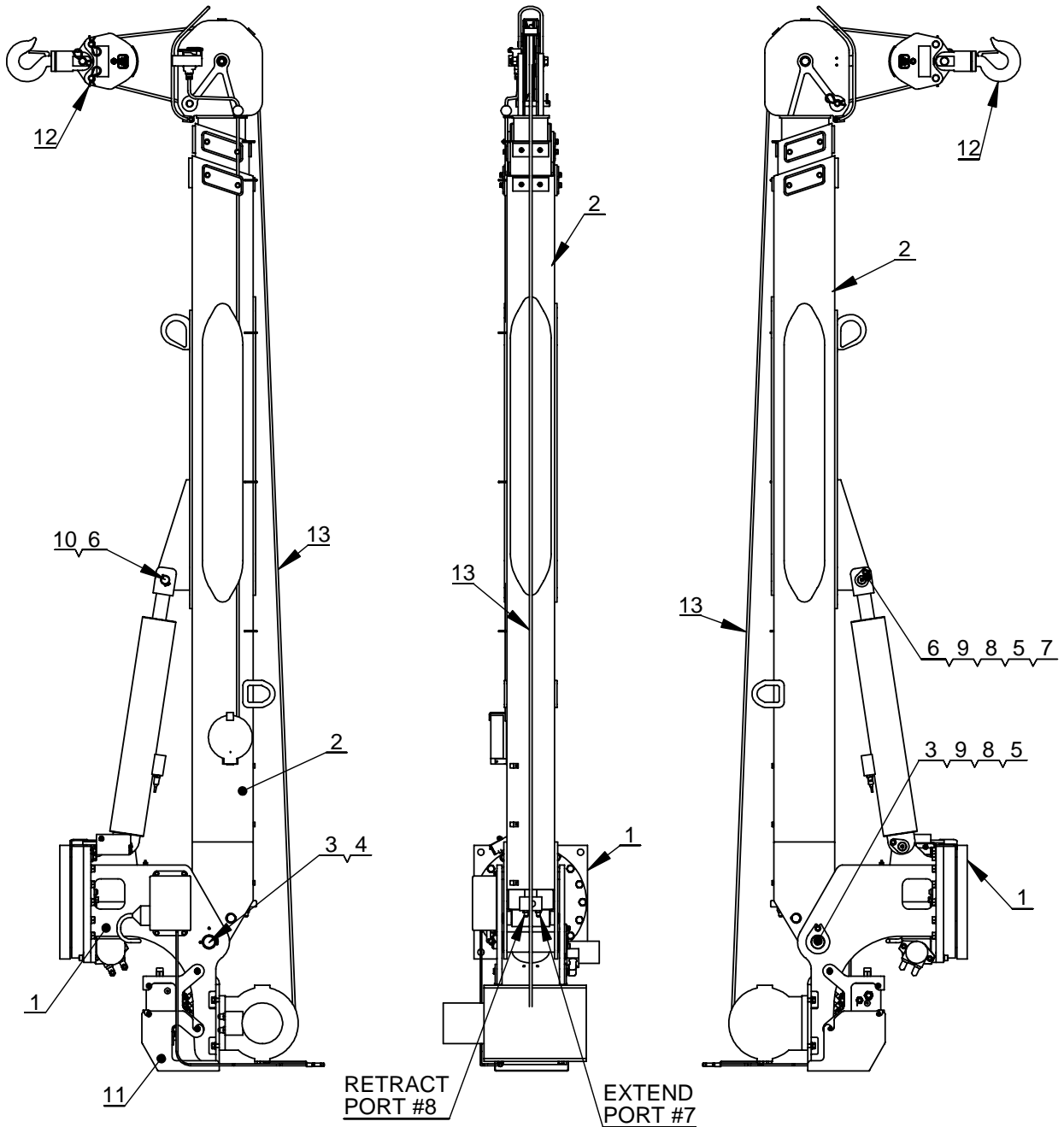

ELECTRICAL SCHEMATIC P/N: 366379000
 HYDRAULIC SCHEMATIC P/N: 366366000

6406H GENERAL ASSEMBLY

FM - P/N: 366720000

ITEM NO.	QTY.	PART NO.	DESCRIPTION
1	1	366740000	PEDESTAL ASSEMBLY
2	1	366630000	BOOM ASSEMBLY
3	1	360675000	PIN, BOOM PIVOT
4	1	360677000	PIN, 1/4 COTTERLESS RING
5	2	008702000	SCW HX 3/8-16 X 1 1/4 GR5
6	1	360676000	PIN, CYLINDER
7	1	239300000	ZERK, GREASE
8	2	021100000	WASHER SP LK 3/8
9	2	320976000	WASHER, FLAT, 3/8 SAE HARDENED
10	1	360678000	PIN, 3/16 COTTERLESS RING
11	1	366430000	COVER 6406
12	1	366398000	TRAVELING BLOCK ASSY 6406H
13	1	480841000	ROPE ASSY
14	1	366339000	SHIP KIT W/ FM CONTROL
15	1	366733000	6406 DECAL LAYOUT

6406H PEDESTAL ASSEMBLY

FM - P/N: 366740000

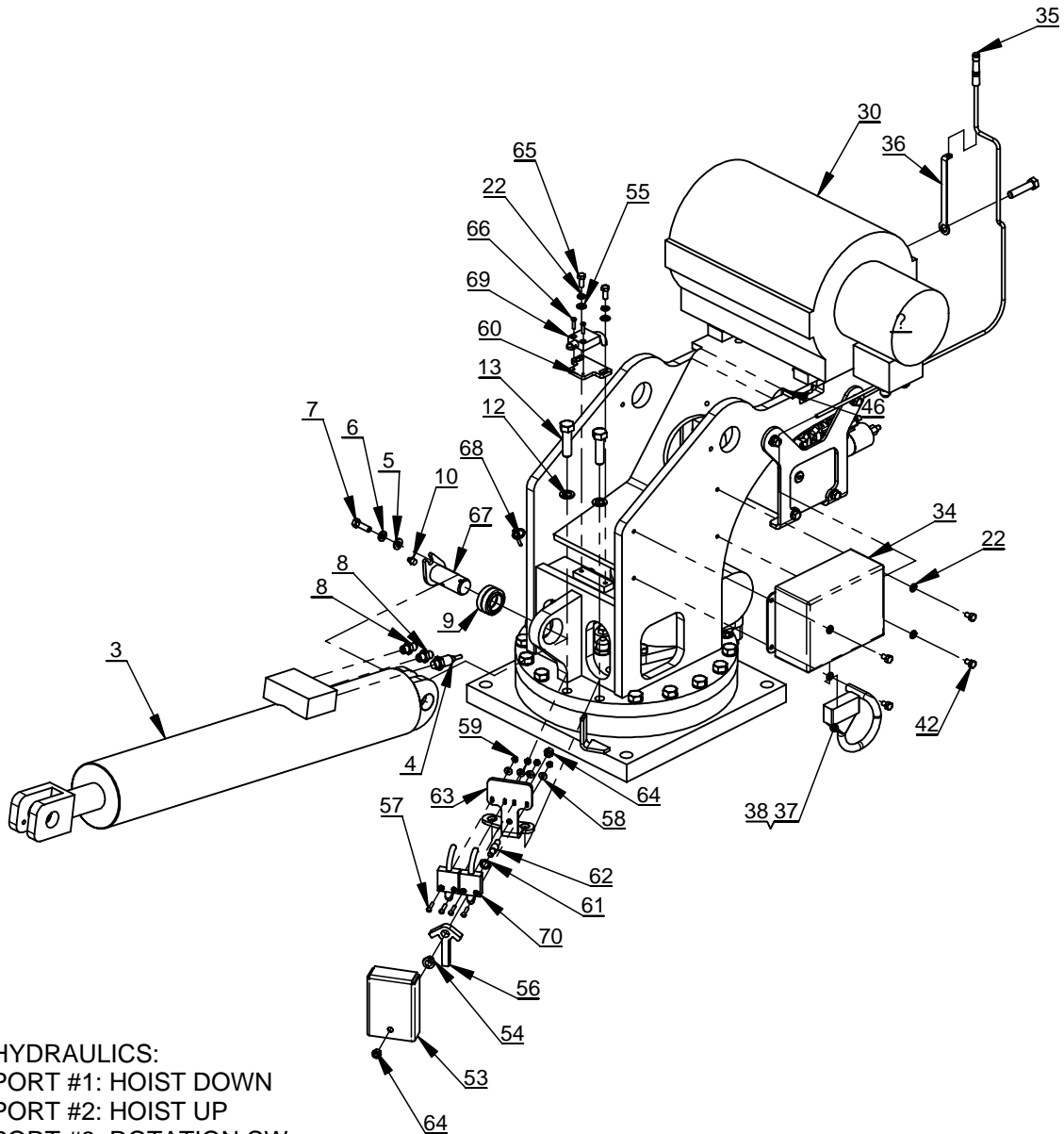

HYDRAULICS:
 PORT #1: HOIST DOWN
 PORT #2: HOIST UP
 PORT #3: ROTATION CW
 PORT #4: ROTATION CCW
 PORT #5: LIFT CYL EXTEND
 PORT #6: LIFT CYL RETRACT
 PORT #7: EXT CYL EXTEND
 PORT #8: EXT CYL RETRACT

CYLINDER SEAL KIT: 366342001
 COUNTER BALANCE CARTRIDGE: 480188000

6406H PEDESTAL ASSEMBLY

FM - P/N: 366740000

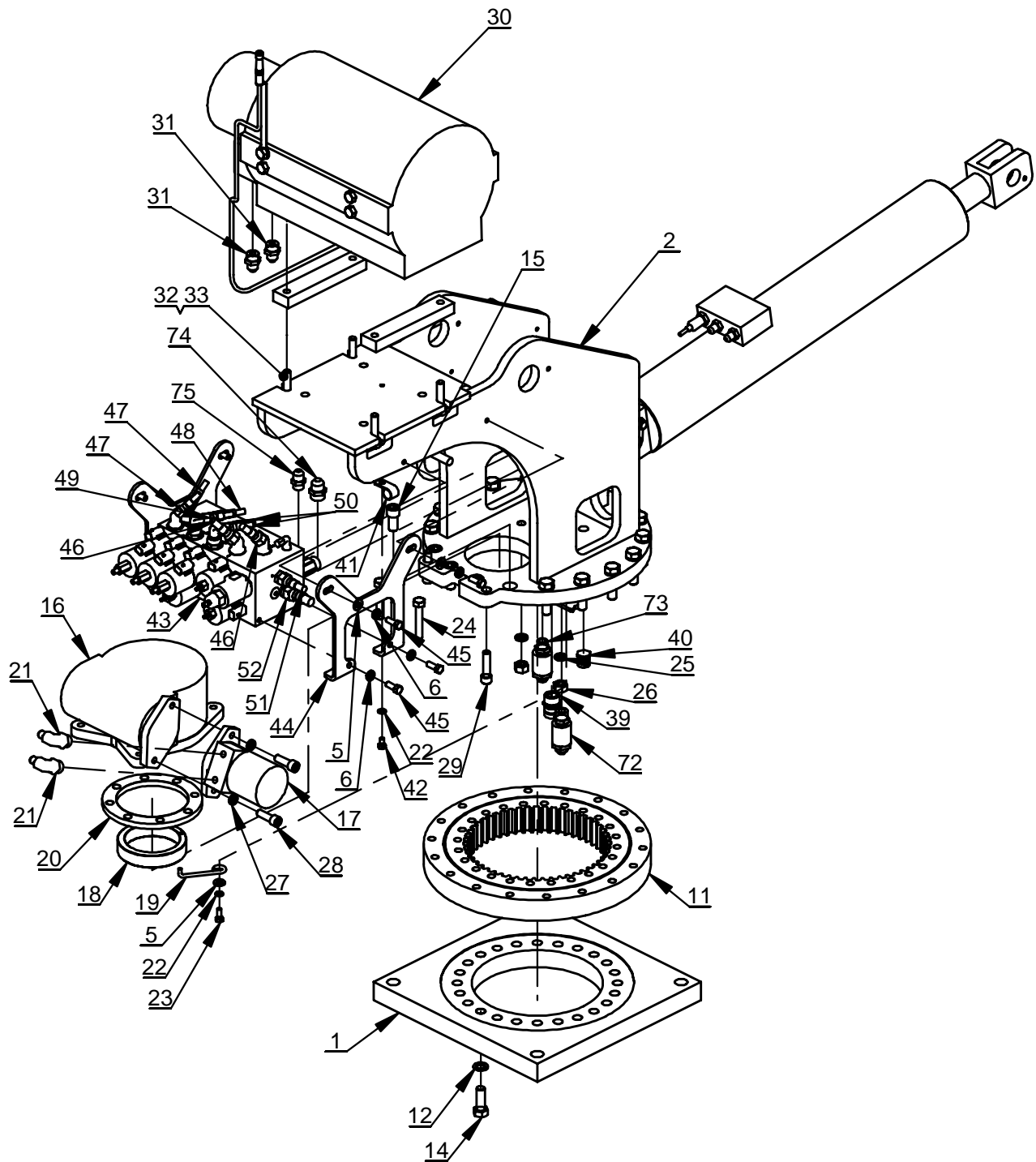

6406H PEDESTAL ASSEMBLY

FM - P/N: 366740000

ITEM NO.	QTY.	PART NO.	DESCRIPTION
1	1	366721000	BASE PLATE WELDMENT
2	1	366741000	PEDESTAL WELDMENT
3	1	366652000	CYLINDER, LIFT
4	1	366478000	PRESSURE TRANSDUCER 4000 PSI
5	6	320976000	WASHER, FLAT, 3/8 SAE HARDENED
6	9	021100000	WASHER SPLK 3/8
7	1	008702000	SCW HX 3/8-16 X 1 1/4 GR5
8	2	200876000	FITTING 6 SAE/6 JIC STRAIGHT
9	1	366333000	BEARING, SPHERICAL 1.25 ID
10	1	239300000	ZERK, GREASE
11	1	480023002	BEARING, ROTATION
12	38	023902000	WASHER, 5/8 FLAT HARDENED
13	14	490171000	CAPSCREW 5/8-11 X 2.25 GR8
14	24	012198000	CAPSCREW 5/8-11 X 1.75 GR8
15	4	006205000	SOC HD 5/8 X 1 1/4
16	1	160407	GEAR BOX, ROTATION
17	1	366440000	ROTATION MOTOR
18	1	360162000	RING, ECCENTRIC
19	1	360207000	RETAINER ECCENTRIC RING
20	1	480011000	SEAL ROTATION BOX
21	2	490198000	FITTING 10SAE(M)/6JIC ELBOW 90
22	8	020601000	WASHER 5/16 LOCK
23	1	007807000	SCW HEX 5/16-18 3/4LG GR5
24	2	011202000	SCW HX HD 1/2-20 X 2 3/4 GR5
25	8	021500000	WASHER SP LK 1/2
26	2	017704000	NUT HX HVY 1/2 NF
27	2	021502000	WASHER SP/LK 1/2 HI COLLAR
28	2	012197000	SOC HD 1/2-13 X 1-1/2
29	2	009118000	SOC HD 1/2 UNC X 2
30	1	123314	HOIST RPH3000
31	2	372041000	FITTING 8JIC/10SAE STRAIGHT 8-10 F5OX
32	4	320588000	WASHER FL 1/2
33	4	366391000	HEX HD 1/2-13 X 2 1/4
34	1	460102004	RECEIVER, 2ND GEN W/6406H PROGRAM
35	1	366500006	CABLE, ANTENNA EXTENSION
36	1	366506000	BRACKET ANTENNA
37	1	366727000	MAIN WIRE HARNESS 6406H/8406H DEUTSCH
38	1	480875000	BOOT DEUTSCH 40-PIN CONNECTOR
39	1	366698000	CORD GRIP .375-.500 3/4" HUB
40	1	642908000	CORD CONNECTOR

6406H PEDESTAL ASSEMBLY

FM - P/N: 366740000

ITEM NO.	QTY.	PART NO.	DESCRIPTION
41	1	480024000	MOUNT PENDANT CABLE RETAINER
42	5	007401000	SCW 5/16-18 X 1/2 LG
43	1	366770000	VALVE, CONTROL 4 FUNCTION W/ PROP FM
44	2	366364000	PLATE, VALVE MOUNTING
45	8	330371000	SCW HX 3/8 UNC X 1 GR8
46	2	480202000	HOSE ASSY 8 STR X 21.5
47	2	812209-022	HOSE ASSY 6 STR/90
48	1	812203-028	HOSE ASSY 6 STR
49	1	812203-030	HOSE ASSY 6 STR
50	2	480205000	HOSE ASSY 6 STR X 19.25
51	1	812309-024	HOSE ASSY 8 STR/90
52	1	812409-022	HOSE ASSY 10 STR/90
53	1	366676000	COVER, ROTATION STOP
54	1	460079000	BEARING, ROTATION STOP
55	2	020901000	WASHER FL 5/16
56	1	366671000	ARM, ROTATION STOP
57	4	460093000	SCW #10-24 X 1 ZP
58	4	020000000	10 SAE FLAT WASHER
59	4	015801000	NUT, #10-24 NYLON LOCK ZP
60	1	366685000	PLATE, BOOM LIMIT SWITCH
61	1	366675000	WASHER, NYLON
62	1	366673000	PIN, ROTATION STOP
63	1	366672000	BRACKET, ROTATION STOP
64	2	017301000	NUT HX NYLON LOCK 3/8 NCCP
65	2	330252000	SCW HX 5/16 NC X 3/4 GR5
66	2	002607000	SCW, #10-24 X 3/4 ZP
67	1	360676000	PIN, CYLINDER
68	1	360678000	PIN, 3/16 COTTERLESS RING
69	1	460111000	BOOM LIMIT SWITCH ASSEMBLY
70	1	460110000	ROTATION STOP SWITCH ASSEMBLY
71	48	374086000	NYLON HOSE SLEEVE
72	1	366358000	FITTING 10SAE/JIC SWIVEL PS810503-10-10
73	1	366359000	FITTING 8 SAE/JIC SWIVEL PS810503-8-8
74	1	490199000	FITTING STR 10-SAE/10-JIC
75	1	367145000	FITTING STR 8-SAE/8-JIC

NOTES

6406H ELECTRICAL SCHEMATIC

FM – P/N: 366379000

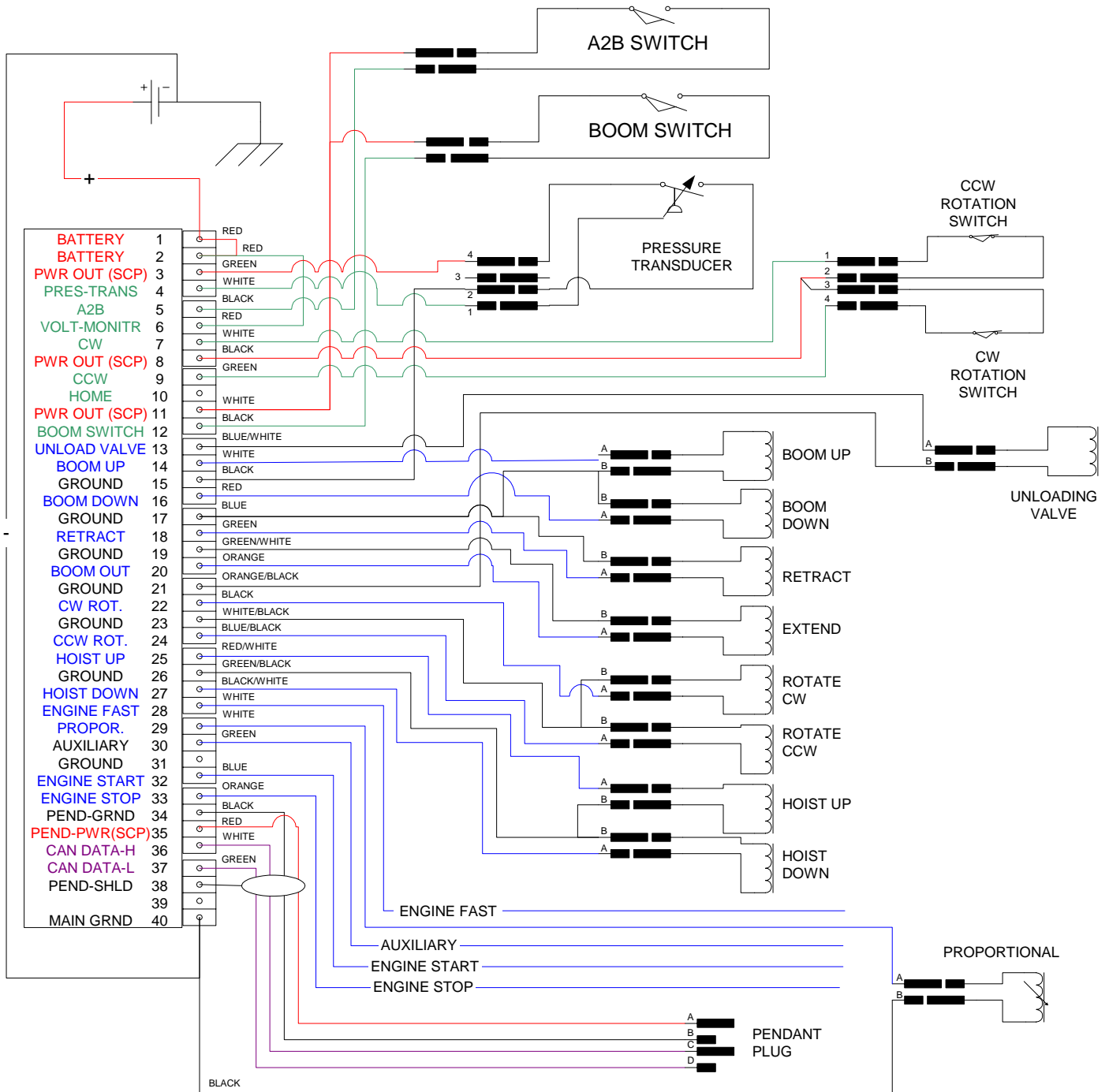

6406H MAIN WIRING HARNESS

FM - P/N: 480883002

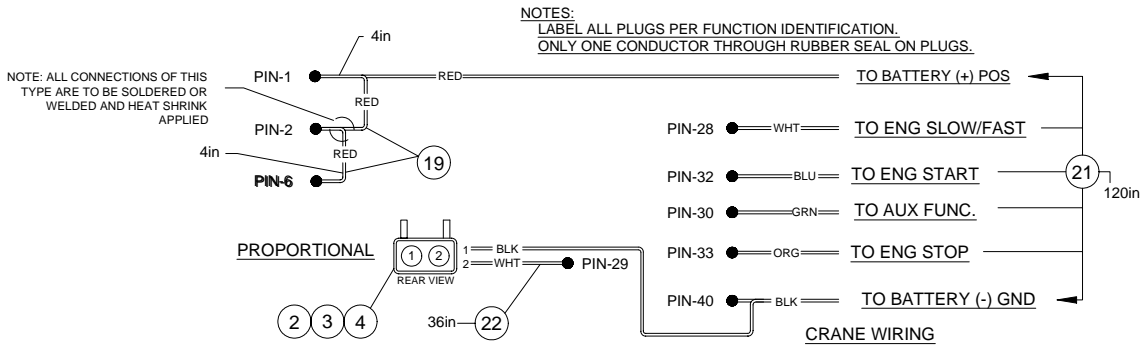
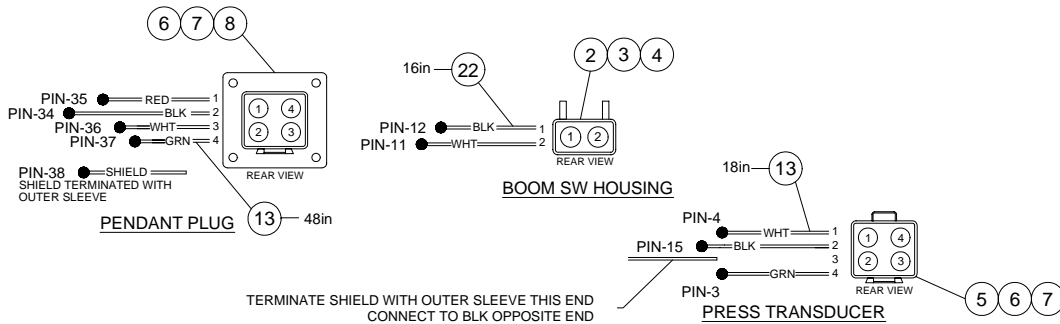
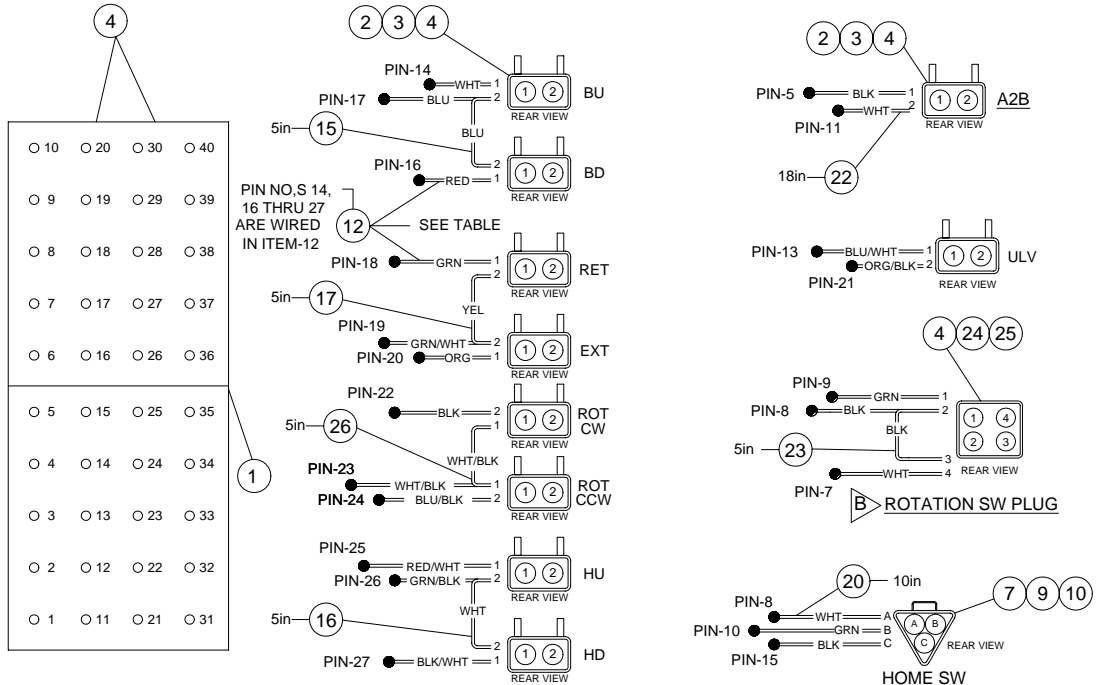

6406H MAIN WIRING HARNESS

FM - P/N: 480883002

ITEM NO.	QTY.	PART NO.	DESCRIPTION
1	1	366377001	HOUSING DEUTSCH 40-PIN
2	12	366367001	HOUSING DEUTSCH PLUG 2-PIN
3	12	366367002	WEDGE DUETSCH PLUG 2-PIN
4	66	366367003	CONTACT DEUTSCH CONNECTOR (SOCKET)
5	1	366376001	HOUSING DEUTSCH RECEPTACLE 4-PIN
6	2	366376002	WEDGE DEUTSCH 4-PIN
7	14	366376003	CONTACT DEUTSCH CONNECTOR (PIN)
8	1	360768001	HOUSING DEUTSCH 4-PIN BULKHEAD RECPT
9	1	360764001	HOUSING DEUTSCH 3-PIN RECEPTACLE
10	1	360764002	WEDGE DEUTSCH 3-PIN
11	1	360769001	HOUSING DEUTSCH 2-PIN RECEPTACLE
12	36 in	800633000	CABLE 16GA 14 COND
13	66 in	750038000	CABLE 18GA 4 COND SHIELDED
14	1	360769002	WEDGE DEUTSCH 2-PIN
15	5 in	800594000	WIRE 16 GA 1 COND BLU
16	7 in	800592000	WIRE 16 GA 1 COND WHT
17	5 in	800596000	WIRE 16GA 1 COND YEL
18	2	360755000	CAVITY PLUG DEUTSCH
19	8 in	800593000	WIRE 16 GA 1 COND RED
20	28 in	800628000	CABLE 16 GA 3 COND
21	120 in	800629000	CABLE 16 GA 6 COND
22	70 in	800626000	CABLE 16 GA 2 COND
23	5 in	800590000	WIRE 16 GA 1 COND BLK
24	1	320931002	WEDGE DEUTSCH PLUG 4-PIN
25	1	320931001	HOUSING DEUTSCH PLUG 4-PIN
26	5 in	800603000	WIRE 16 GA 1 COND WHT/BLK

REMOTE / PENDANT PARTS AND ACCESSORIES

<u>Component</u>	<u>Part Number</u>
Receiver	460102004
Transmitter	460100002
Pendant Cable	366500009
Antenna	366500005
Antenna Extension Cable	366500006
Cigarette Lighter Charger	366504000
A/C Charger	366505000
Palm Diagnostic Unit	366510000

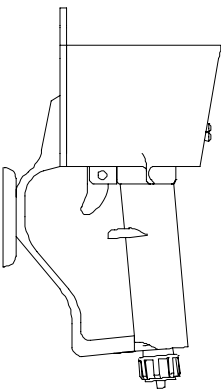

Transmitter

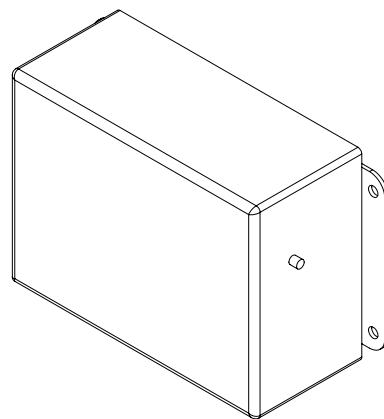
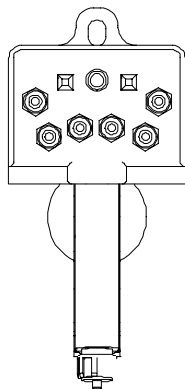

Receiver

6406H PENDANT ASSEMBLY

FM - P/N: 460100002

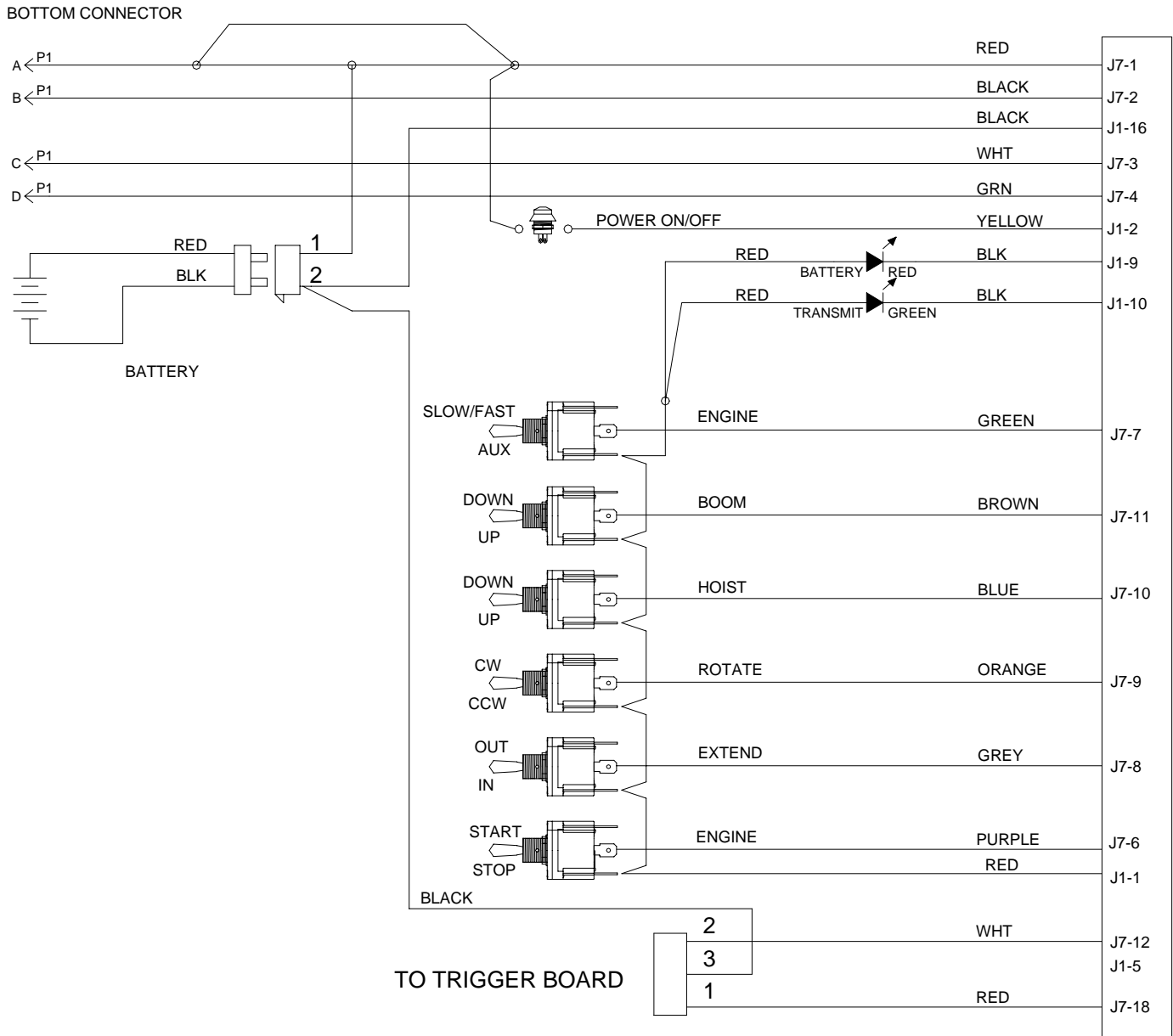

6406H PENDANT ASSEMBLY

FM - P/N: 46010002

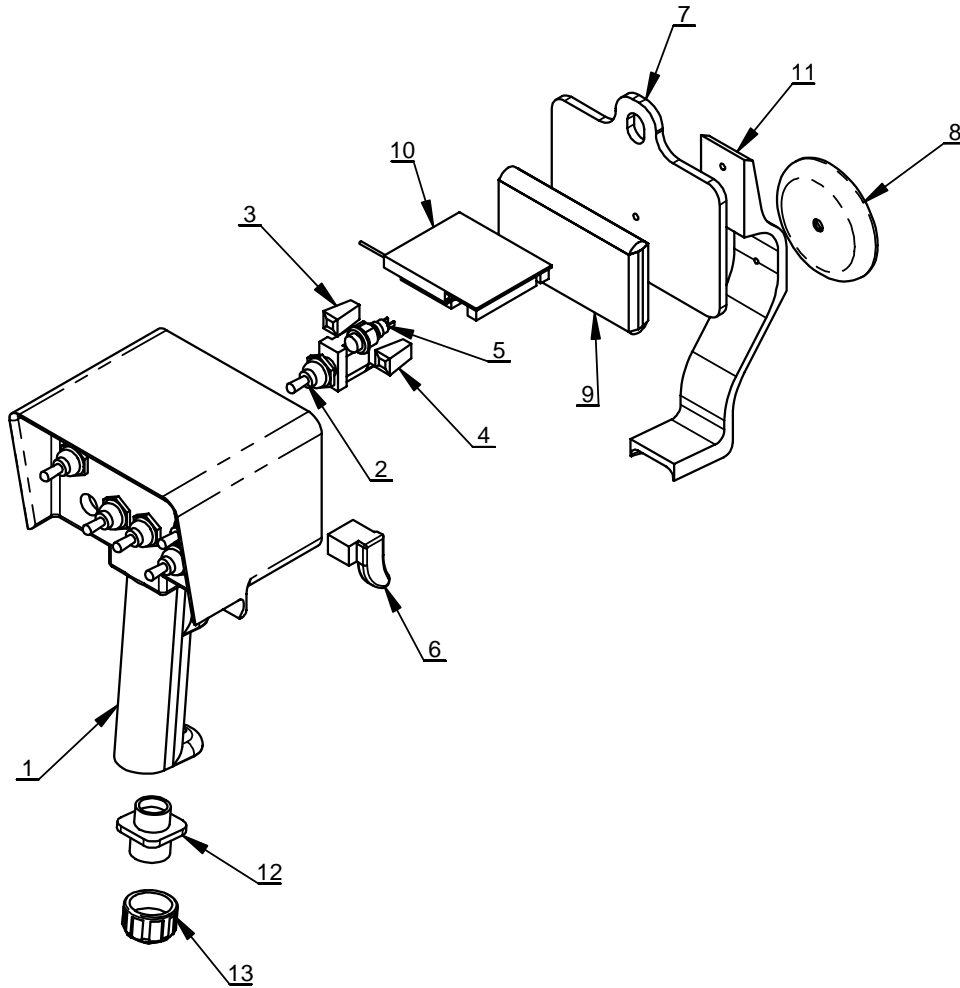

ITEM NO.	QTY.	PART NO.	DESCRIPTION
1	1	366531000	TRANSMITTER, HOUSING KAR-TECH 2ND GEN
2	6	366500018	SWITCH, TOGGLE W/RESISTOR KAR-TECH
3	1	366536000	LIGHT, RED TRANSMITTER KAR-TECH
4	1	366535000	LIGHT, GREEN TRANSMITTER KAR-TECH
5	1	366537000	SWITCH, POWER, RED TRANSMITTER, KAR-TECH
6	1	460100010	TRIGGER, HALL EFFECT TRANSMITTER KAR-TECH
7	1	366532000	REAR COVER, TRANSMITTER KAR-TECH
8	1	366501000	MAGNET
9	1	460100008	BATTERY, TRANSMITTER KAR-TECH
10	1	366534000	COMPUTER BOARD, TRANSMITTER, KAR-TECH 2ND GEN
11	1	366533000	HAND GUARD, TRANSMITTER KAR-TECH
12	1	366538000	CONNECTOR, CAN/CHARGER TRANSMITTER KAR-TECH
13	1	366539000	CAP, CONNECTOR CAN/CHARGER KAR-TECH

TRANSMITTER / RECEIVER SYNCHRONIZATION

1. Power on the transmitter and receiver.
2. Connect the transmitter to the receiver via the CAN/charger cable.
3. Operate the transmitter for 5 to 10 seconds or until the green light on the transmitter starts flashing again.

NOTES

6406H FUSE INFORMATION

FM - P/N: 460102004

NOTE: Always turn power to crane off before removing fuse.

Fuse is on ground circuit. The fuse can be replaced with a 7.5 amp fuse

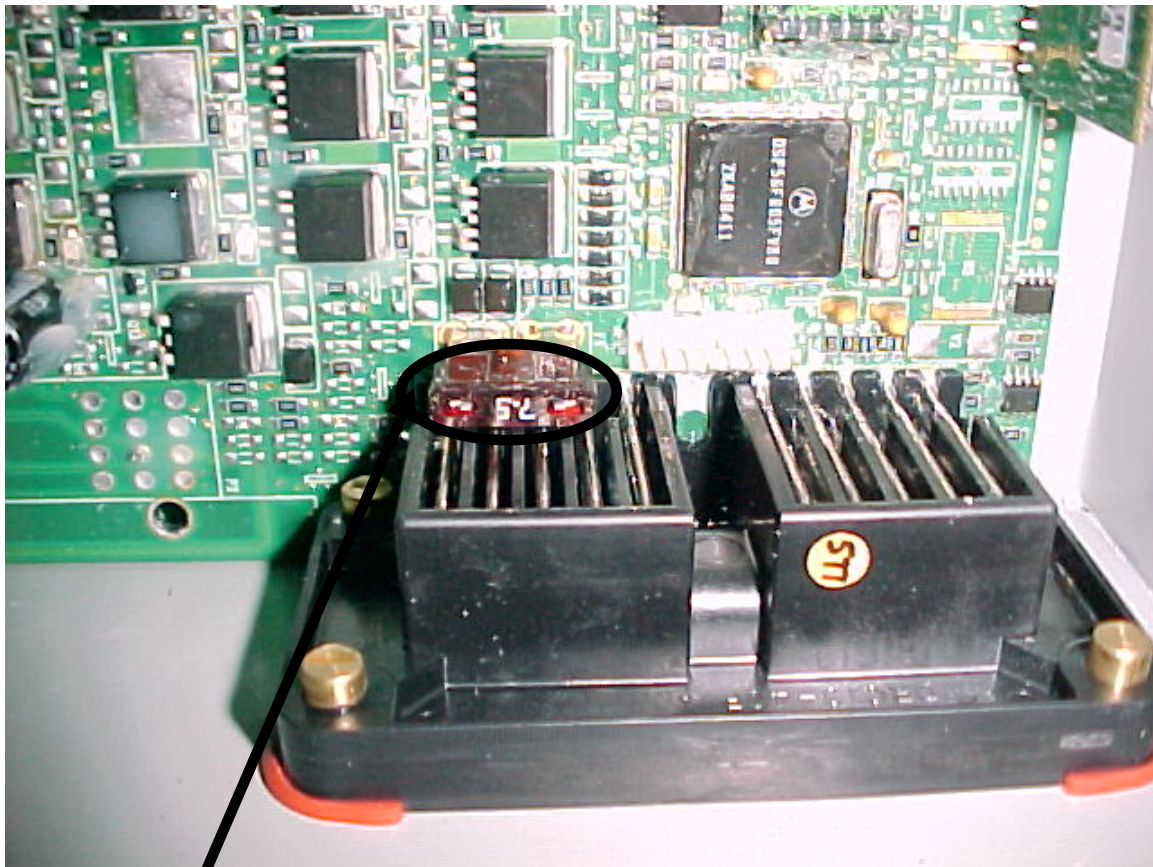

FUSE

6406H HYDRAULIC CONTROL VALVE

FM - P/N: 366770000

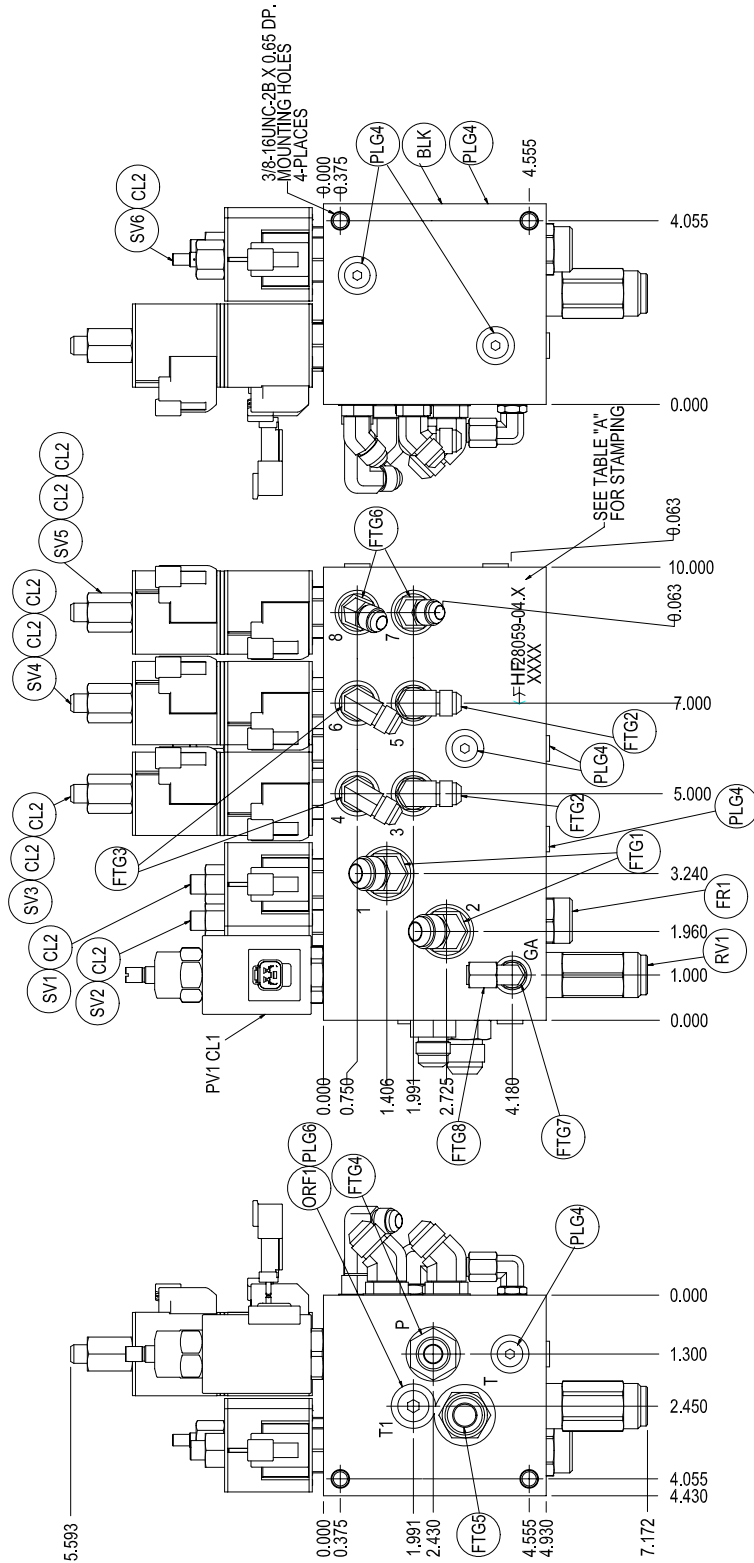

6406H HYDRAULIC CONTROL VALVE

FM - P/N: 366770000

ITEM NO.	QTY.	PART NO.	DESCRIPTION
PV1	1	366365002	PROP VALVE
CL1	1	366370001	COIL
FR1	1	366365003	FLOW CONTROL
RV1	1	366365004	RELIEF VALVE
SV6	1	366760001	UNLOAD VALVE
SV1,SV2	2	480186000	CART VALVE
SV3,SV4,SV5	3	320725001	CART VALVE
CL2	9	460160002	COIL
ORF1	1		PLUG ORIFICE
FTG1	2	374017000	FITTING
FTG2	2	330272000	FITTING
FTG3	2	480194000	FITTING
FTG4	1	367145000	FITTING
FTG5	1	490199000	FITTING
FTG6	2	466207000	FITTING
FTG7	1	369127000	FITTING
FTG8	1	330348000	FITTING
PLG4	7		PORT
PLG6	1		PORT
NOT SHOWN	23		PLUG
BLK	1		BLOCK

6406H DIAGNOSTICS

SITUATION	POSSIBLE SOLUTION
FLOW PRESENT BUT FUNCTION WILL NOT WORK	Check receiver for error code, if error code is present while function is being activated, refer to the error code section on the following page. If "NRML" appears in the code display on the receiver while the function is being activated, operate the proportional override and push or pull the override on the directional control valve to operate the function. If the function still does not operate, see the "NO FLOW" paragraph in this section.
HYDRAULIC "CHATTER"	When a hydraulic function is engaged and causes the crane to "chatter", check for error code on receiver display, low pump pressure or air in the system.
NO FLOW OR LIMITED FLOW TO CRANE	Check for error code on receiver display (see error code section). Check for adequate oil supply in reservoir. Check operation of bypass system by operating the override on the proportional valve while operating crane. If low flow condition continues to exist when the manual override is operated, remove relief valve cartridge and check for dirt. Other possible causes for a low flow condition are: <ol style="list-style-type: none"> 1. Engine speed is too slow. 2. A blocked pressure hose from pump. Excessive lugging of engine and rapid overheating of oil can identify this condition. 3. Collapsed or blocked suction hose to pump. This condition is usually identified by pump cavitation noise. 4. Bad pumps: a bad pump will usually have some flow but the flow will drop off rapidly as pressure increases. This condition will cause overheating of the system. A drop of four (4) or more GPM from Zero (0) PSI to Two Thousand (2000) PSI is cause for pump investigation.
NO PRESSURE OR TOO LOW PRESSURE	Check the sight gauge and maintain an adequate oil level in reservoir. Make sure pressure gauge is functioning correctly. Possible relief valve stuck open. Check for excessive leakage and correct.
TOO HIGH FLOW	Make sure pump size is correct and pump speed is not too fast (Consult manufacturer's data sheet). Check or replace flow control. Check components for flow displacements. High flow may cause erratic valve operation.
TOO HIGH PRESSURE	Make sure pressure relief valve is correctly set.

CAUTION

The Auto Crane 6406H series cranes are manufactured with a standard overload protection system to prevent structural damage to the crane. When the crane load rating is exceeded, main boom down, extend out, and hoist up will not function. These operations cannot be used again until the load on the crane is reduced. Also, the main boom elevation will be limited in its operation as the crane becomes overloaded. Attempting to raise the main boom with a load greatly exceeding the crane rating will open the main relief valve resulting in no boom movement. Moving the load closer to the crane pedestal, or reducing the load can resolve this problem.

CONTROLLER DIAGNOSTICS

CODE: EC01
DESCRIPTION: Signal problem
POSSIBLE CAUSE(S): No signal from transmitter/pendant or transmitter power off.
POSSIBLE SOLUTION(S): Check transmit light on transmitter, light should flash when function is activated. If light does not flash, make sure transmitter is on. If light flashes and red low battery light flashes, charge unit. If transmitter is plugged in as a pendant and transmit light comes on but code remains, check cable connections and cable.

CODE: EC02
DESCRIPTION: Boom up
POSSIBLE CAUSE(S): Short or open connection on boom up output.
POSSIBLE SOLUTION(S): Check plug in boom up solenoid on hydraulic control valve. Check wires for damage that could cause break or short.

CODE: EC03
DESCRIPTION: Boom down
POSSIBLE CAUSE(S): Short or open connection on boom down output.
POSSIBLE SOLUTION(S): Check plug in boom down solenoid on hydraulic control valve. Check wires for damage that could cause break or short.

CODE: EC04
DESCRIPTION: Boom in (retract)
POSSIBLE CAUSE(S): Short or open connection on boom in output.
POSSIBLE SOLUTION(S): Check plug in boom in solenoid on hydraulic control valve. Check wires for damage that could cause break or short.

CODE: EC05
DESCRIPTION: Boom out (extend)
POSSIBLE CAUSE(S): Short or open connection on boom out output.
POSSIBLE SOLUTION(S): Check plug in boom out solenoid on hydraulic control valve. Check wires for damage that could cause break or short.

CODE: EC06
DESCRIPTION: Rotate CW
POSSIBLE CAUSE(S): Short or open connection on rotate CW output.
POSSIBLE SOLUTION(S): Check plug in rotate CW solenoid on hydraulic control valve. Check wire for damage that could cause break or short.

CODE: EC07
DESCRIPTION: Rotate CCW
POSSIBLE CAUSE(S): Short or open connection on rotate CCW output.
POSSIBLE SOLUTION(S): Check plug in rotate CCW solenoid on hydraulic control valve. Check wire for damage that could cause break or short.

CODE: EC08
DESCRIPTION: Hoist up
POSSIBLE CAUSE(S): Short or open connection on hoist up output.
POSSIBLE SOLUTION(S): Check plug in hoist up solenoid on hydraulic control valve. Check wire for damage that could cause break or short.

CONTROLLER DIAGNOSTICS

CODE: EC09
DESCRIPTION: Hoist down
POSSIBLE CAUSE(S): Short or open connection on hoist down output.
POSSIBLE SOLUTION(S): Check plug in hoist down solenoid on hydraulic control valve. Check wire for damage that could cause break or short.

CODE: EC10
DESCRIPTION: Incorrect ID
POSSIBLE CAUSE(S): Signal received from transmitter with incorrect ID code.
POSSIBLE SOLUTION(S): Confirm that transmitter being used is for use with this unit. Follow 'New Transmitter' procedure in the transmitter operation section of this manual.

CODE: EC11
DESCRIPTION: Ground missing
POSSIBLE CAUSE(S): Fuse in receiver may be blown.
POSSIBLE SOLUTION(S): Check the fuse in the receiver, fuse is on the ground circuit. Do not check for voltage.

CODE: EC12
DESCRIPTION: Short circuit in power circuit
POSSIBLE CAUSE(S): Power provided to the switches etc. is shorted to ground.
POSSIBLE SOLUTION(S): Check the wiring on the pendant cable, the anti-two block, the pressure sensor, the boom limit switch, the home switch and the rotation stop for a short to ground.

CODE: EC13
DESCRIPTION: Auxiliary not wired
POSSIBLE CAUSE(S): Short or open connection on auxiliary.
POSSIBLE SOLUTION(S): This error should only be seen on a Palm unit and should only occur when the auxiliary function is not connected.

CODE: EC15
DESCRIPTION: Pressure sensor
POSSIBLE CAUSE(S): Pressure sensor problem.
POSSIBLE SOLUTION(S): Check plugs and wires coming from pressure sensor mounted in the lift cylinder counterbalance valve.

CODE: EC16
DESCRIPTION: Trigger
POSSIBLE CAUSE(S): Transmitter trigger problem.
POSSIBLE SOLUTION(S): Check trigger for damage, contamination or incorrect adjustment.

CODE: EC17
DESCRIPTION: Trigger logic error
POSSIBLE CAUSE(S): Trigger was activated before function switch was activated.
POSSIBLE SOLUTION(S): Confirm that trigger is released and returned to full off position, activate function and reactivate trigger.

CODE: EC18
DESCRIPTION: Proportional output error
POSSIBLE CAUSE(S): Short or open connection on proportional output.
POSSIBLE SOLUTION(S): Check plug in proportional solenoid on hydraulic control valve. Check wire for damage that could cause break or short.

CONTROLLER DIAGNOSTICS

CODE: EC19
DESCRIPTION: Unloader error
POSSIBLE CAUSE(S): Short or open connection on unloader output.
POSSIBLE SOLUTION(S): Check plug in hoist down solenoid on hydraulic control valve. Check wire for damage that could cause break or short.

CODE: LBV
DESCRIPTION: Low battery
POSSIBLE CAUSE(S): Low battery power to receiver.
POSSIBLE SOLUTION(S): Check connections to the battery. Charge battery. NOTE: It is recommended that the crane be powered off if battery is charged with battery charger.

CODE: HBV
DESCRIPTION: High battery
POSSIBLE CAUSE(S): High battery power to receiver.
POSSIBLE SOLUTION(S): Check the battery. Truck battery voltage is greater than 15V

CODE: OVL
DESCRIPTION: Overload
POSSIBLE CAUSE(S): Pressure overload.
POSSIBLE SOLUTION(S): Retract boom, hoist down or otherwise alleviate overload condition. Refer to load chart for rated load. If the error persists with seemingly light loads, install pressure gage in plugged port of lift cylinder counterbalance valve to confirm pressures in excess of 2,500 psi. Pressure sensor can give false readings if not properly grounded.

CODE: RS1
DESCRIPTION: Rotation switch tripped.
POSSIBLE CAUSE(S): Rotation stop reached in clockwise direction.
POSSIBLE SOLUTION(S): This is not an error. Rotate in opposite direction or check switch for interference.

CODE: RS2
DESCRIPTION: Rotation switch tripped.
POSSIBLE CAUSE(S): Rotation stop reached in counter-clockwise direction.
POSSIBLE SOLUTION(S): This is not an error. Rotate in opposite direction or check switch for interference.

CODE: A2B
DESCRIPTION: Anti-two block
POSSIBLE CAUSE(S): Anti-two block switch tripped.
POSSIBLE SOLUTION(S): Check switch, if not mechanically tripped, check continuity across switch at plug. If switch has continuity check voltage across transmitter side of A2B plug. If low voltage is read, power to the A2B switch, the rotation switches or the pressure sensor may have a short.

CONTROLLER DIAGNOSTICS

CODE: **RSBM**
DESCRIPTION: Raise boom
POSSIBLE CAUSE(S): Pressure sensor is reading less than 80 psi.
POSSIBLE SOLUTION(S): Raise boom to ensure it is not resting on other structure and the lift cylinder is not bottomed out.

CODE: **NRML**
DESCRIPTION: Normal operating mode
POSSIBLE CAUSE(S): Crane is functioning properly.
POSSIBLE SOLUTION(S): This is not an error. It is a standard normal operation readout.

CODE: **SLOW**
DESCRIPTION: Slow operating mode
POSSIBLE CAUSE(S): Crane is functioning properly if loaded or boom down activated.
POSSIBLE SOLUTION(S): This is not an error. It is a standard slow operation readout. If the crane is not loaded booming up should clear this code.

CODE: **BMLT**
DESCRIPTION: Boom limit
POSSIBLE CAUSE(S): Boom has reached maximum elevation.
POSSIBLE SOLUTION(S): This is not an error. It only indicates boom position. Lower the boom to deactivate the switch.

6406H LOAD CHART

P/N: 366724000

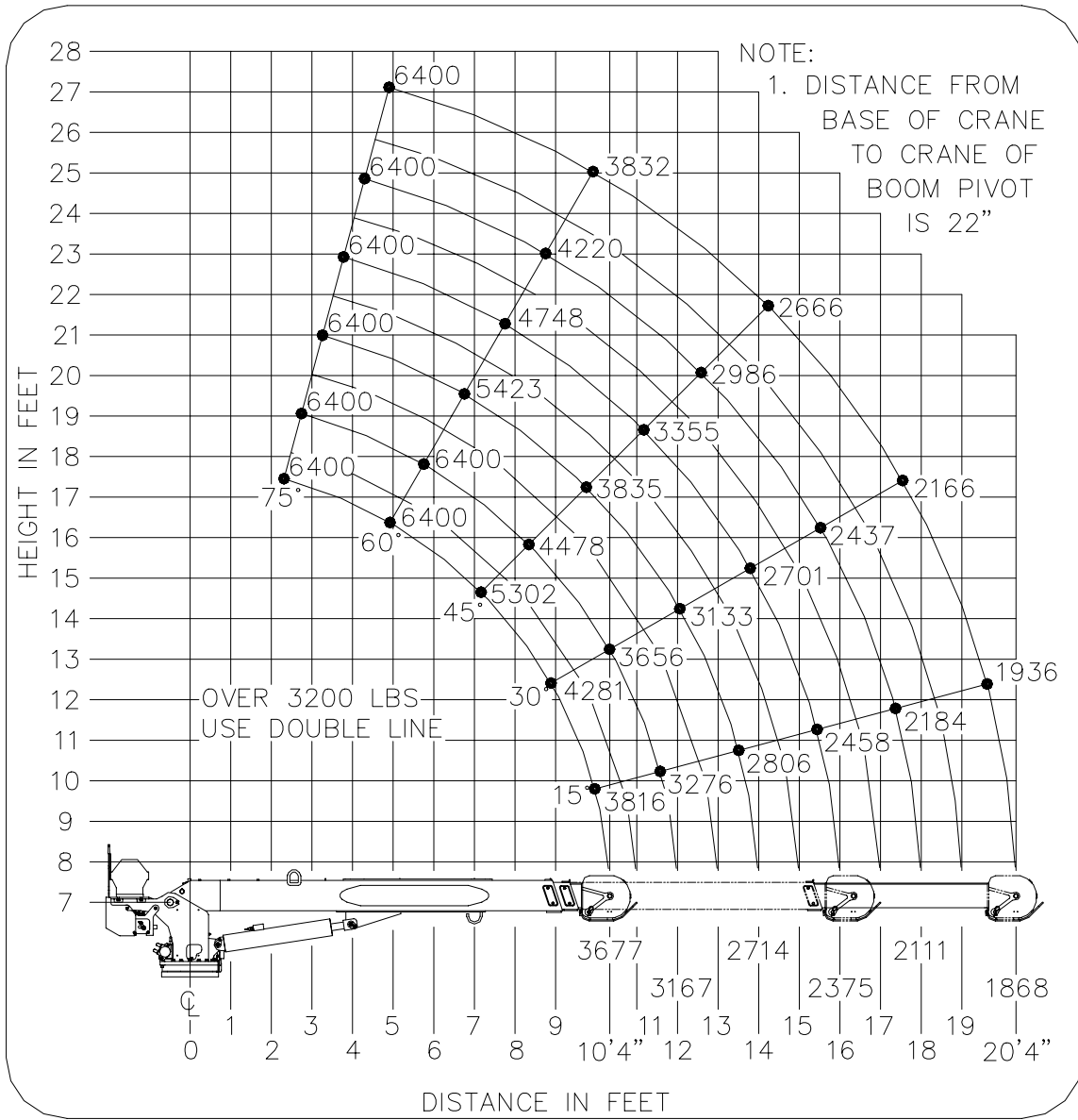

NOTES



P.O. Box 580697 * Tulsa, OK 74158-0697
4707 N. Mingo Rd. * Phone (918) 836-0463

LIMITED WARRANTY 2 YEAR PARTS AND LABOR

Auto Crane will warranty to the consumer for a period of (2) years parts and labor from the date of purchase. Each new Auto Crane unit they sell will be free under normal use and service from defects in material and workmanship. Date of purchase will be honored as the date indicated on the Bill of Sale, which must accompany the Warranty Registration and be on file with Auto Crane. Absent a valid Warranty Registration and appropriate documentation, the original date of manufacture, as indicated by the serial number on the product, will be used to determine the effective date of the 2 year warranty.

The obligation of Auto Crane under this warranty is limited to the replacement or repair of parts that appear to the manufacturer after review and/or inspection to be defective and paid flat rate labor for replacing defective parts. This warranty does not obligate Auto Crane to bear the travel time charges in connection with the replacement or repair of defective parts. Responsibility for customer's claims arising from misapplication, abuse, misuse or alteration of equipment or parts lies with the distributor or user and no warranty obligation is assumed in these circumstances by Auto Crane.

Auto Crane will in no event be liable for any consequential damages or contingent liabilities arising out of the failure of any Auto Crane Product or parts to operate properly.

Auto Crane makes no warranty in respect to component accessories, it being subject to the warranties of their respective manufacturers.

If field service, at the request of the distributor, is rendered and fault is found not to be with Auto Crane's product, the distributor shall pay the time and expense of the field representative.

Claims for service labor or other expenses that have incurred by the buyer without approval or authorization or Auto Crane will not be accepted.

When applying for warranty, claims may be handled by contacting your nearest authorized Auto Crane Distributor. All claims are to be filed in writing on an Auto Crane Warranty Claim Form.

AUTO CRANE COMPANY IS UNDER NO OBLIGATION TO EXTEND THIS WARRANTY TO ANY CUSTOMER FOR WHICH AN AUTO CRANE DELIVERY REPORT FORM HAS NOT BEEN COMPLETED AND ON FILE WITH AUTO CRANE COMPANY

