

# **OWNERS MANUAL**

## **6006EH**

**REVISION 2/2000**

PART NO. 999979

**SERIAL NO.** \_\_\_\_\_

## **AUTO CRANE COMPANY**

PO BOX 580697, TULSA, OK 74158-0697

4707 N. MINGO ROAD, TULSA, OK 74117-5904

PHONE (918) 836-0463

SALES FAX (918) 438-6688 SERVICE FAX (918) 834-5979

[www.autocrane.com](http://www.autocrane.com)

**!! DISTRIBUTORS !!**

**PROTECT YOUR CUSTOMER'S WARRANTY!  
SUBMIT DELIVERY REPORT WITHIN 15 DAYS.**

Mail to: Auto Crane Company  
P.O. Box 580697  
Tulsa, OK 74158-0697

Or Fax to: 918/834-5979

Protect your customers warranty - Submit within 15 days from delivery date.



**AUTO CRANE COMPANY**

**DISTRIBUTOR  
DELIVERY REPORT**

DISTRIBUTOR _____		OWNER _____	
ADDRESS _____		CITY/STATE _____	
CITY/STATE/ZIP _____		BUSINESS _____	
MODEL #	SERIAL #	DATE DELIVERED	UNIT DESTINATION

**IMPORTANT: ATTACH SIGNED COPY OF CUSTOMER INVOICE / DELIVERY RECEIPT**

AC-109 REPORT AUTHORIZED BY: \_\_\_\_\_

**\* REGISTER ONE UNIT ONLY PER CARD \***

# ***WARNINGS - READ THIS PAGE!***

**WARNING!** Federal law (49 cfr part 571) requires that the Final Stage Manufacturer of a vehicle certify that the vehicle complies with all applicable federal regulations. Any modifications performed on the vehicle prior to the final stage are also considered intermediate stage manufacturing and must be certified as to compliance. The installer of this crane and body is considered one of the manufacturers of the vehicle. As such a manufacturer, the installer is responsible for compliance with all applicable federal and state regulations, and is required to certify that the vehicle is in compliance.

**WARNING!** It is the further responsibility of the installer to comply with the OSHA Truck Crane Stability Requirements as specified by 29 CFR part 1910.180 (C) (1).

**WARNING! NEVER OPERATE THE CRANE NEAR ELECTRICAL POWER LINES!** Death or serious injury will result from boom, line, or load contacting electric lines. Do not use crane within 10 feet (3.05m) of electric power lines carrying up to 50,000 volts. One foot additional clearance is required for every additional 30,000 volts or less.

**WARNING! NEVER .....**

- v **EXCEED** load chart capacities (centerline of rotation to hoist hook).
- v un-reel last 5 wraps of cable from drum!
- v wrap cable around load!
- v attempt to lift or drag a load from the side! The boom can fail far below its rated capacity.
- v weld, modify, or use unauthorized components on any Auto Crane unit! This will void any warranty or liability. Also failure of the crane may result.
- v place a chain link on the tip of the hook and try to lift a load!
- v use a sling bar or anything larger than the hook throat that could prevent the hook latch from closing, thus negating the safety feature!
- v hold on any pendant Select Switch that will cause unsafe operating conditions!

**WARNING!** In using a hook with latch, **ALWAYS** make sure that the hook throat is closed before lifting a load! Proper attention and common sense applied to the use of the hoist hook and various slings will prevent possible damage to material being hoisted and may prevent injury to personnel.

**WARNING!** Failure to correctly plumb and wire crane can cause inadvertent operation and damage to crane and/or personnel!

**WARNING!** Auto Crane Company remote controlled cranes are not designed or intended to be used for any applications involving the lifting or moving of personnel.

**WARNING! ALWAYS** operate the crane in compliance with the load capacity chart. **Do not use** the overload shutdown device to determine maximum rated loads, if your crane is equipped with this type of device.



6006EH SERIES - OWNER'S MANUAL  
**TABLE OF CONTENTS**



	PAGE
INTRODUCTION .....	1-1.0.0
OPERATING PRACTICES & WARNINGS .....	2-1.0.0
SAFETY DECAL SECTION .....	2-2.0.0
OPERATION OF UNIT/OUTRIGGERS .....	3-1.0.0
QUALIFICATIONS FOR OPERATORS .....	3-2.0.0
INSPECTION, TESTING, & MAINTENANCE .....	3-3.0.0
GENERAL DIMENSIONS AND SPECIFICATIONS .....	4-0.0.0
BOOM SUPPORT .....	4-2.0.0
STABILIZERS .....	4-3.0.0
INSTALLATION .....	4-4.0.0
LUBRICATION AND MAINTENANCE .....	5-1.0.0
BATTERY MAINTENANCE .....	7-1.0.0
OVERLOAD SYSTEM .....	7-2.0.0
RELIEF AND COUNTERBALANCE SETTING .....	7-3.0.0
PEDESTAL ASSEMBLY .....	8-0.0.0
BOOM ASSEMBLY .....	9-0.0.0
HYDRAULIC ASSEMBLY .....	11-0.0.0
HYDRAULIC PUMP AND RESERVOIR .....	13-0.0.0
ROTATION GEAR BOX .....	14-0.0.0
VOLTAGE SWITCHING UNIT .....	15-0.0.0
ELECTRICAL SCHEMATIC .....	16-1.0.0
2-BLOCK ASSEMBLY .....	18-0.0.0
RELAY BOX ASSEMBLY .....	19-0.0.0
PENDANT ASSEMBLY .....	20-0.0.0
DECAL LAYOUT .....	25-0.0.0
SAFETY BRAKE.....	27-0.0.0
TRAVELING BLOCK .....	28-0.0.0
LOAD CHART .....	29-0.0.0
WARRANTY .....	LAST PAGE

# INTRODUCTION

## 6006EH SERIES

Auto Crane products are designed to provide many years of safe, trouble-free, dependable service when properly used and maintained.

To assist you in obtaining the best service from your crane and to avoid untimely crane and/or vehicle failure, this manual provides the following operating and service instructions. It is **specifically recommended** that all operating and service personnel consider this manual as mandatory material for reading and study before operating or servicing Auto Crane products. It is **highly recommended** that crane owners, equipment managers and supervisors also read this manual.

Auto Crane has incorporated several safety features in the 6006EH series cranes for your protection. The hydraulic components meet or exceed a **3.5:1 safety factor**. Holding valves prevent the load from dropping if a hose should fail. The reservoir has a **15µ air filter** in the filler cap. The pump has a **40 mesh strainer** in the suction line.

For your convenience the overall dimensions of the 6006EH series crane are on the General Dimension Drawing. Maximum turning radius at both the hoist motor and the rotation motor are also on that drawing.

Remember, the crane adds weight to the vehicle. Adding weight may change the driving and riding characteristics of the vehicle unless the appropriate overload spring(s) are installed on the truck. The payload of the vehicle is reduced by the weight of the crane. The operator should exercise care when loading the vehicle. Distributing the payload on the vehicle evenly will greatly improve the driving and riding characteristics of the vehicle. **A minimum G.V.W. of 14,500 lbs is recommended for mounting the 6006EH series cranes.**

---

**Auto Crane Company issues a limited warranty certificate with each unit sold. See last page for warranty policy.**

---

It has always been Auto Crane Company policy to handle all warranty claims we receive as promptly as possible. If a warranty claim involves discrepant material or workmanship, Auto Crane will take immediate corrective action. It is understandable that Auto Crane Company cannot assume responsibility of liability when it is obvious that our products have been

abused, mis-used, overloaded or otherwise damaged by inexperienced persons trying to operate the equipment without reading the manual.

**Auto Crane will not assume responsibility or liability for any modifications or changes made to unit, or installation of component parts done without authorization.**

Auto Crane maintains a strong distributor network and a knowledgeable Customer Service Department. In most cases, an equipment problem is solved via phone conversation with our customer service department. The customer service department also has the ability to bring a local distributor, a regional sales manager, or a factory serviceman into the solution of an equipment problem. If, through no fault of Auto Crane Company, it is necessary to send an experienced factory serviceman on a field service call, the rates stated in the Auto Crane Distributor's Flat Rate Manual will apply.

Auto Crane Company's extensive Research and Development Program allow our customers to use the best equipment on the market. Our Engineering Staff and our knowledgeable sales people, are always available to our customers in solving crane and winch-type application problems. When in doubt, call the Auto Crane factory.

### **DISTRIBUTOR ASSISTANCE:**

Should you require any assistance not given in this manual, we recommend that you consult your nearest Auto Crane Distributor. Our distributors sell authorized parts and have service departments that can solve almost any needed repair.

---

***NOTE: THIS MANUAL SHOULD REMAIN WITH THE CRANE AT ALL TIMES.***

---

This manual does not cover all maintenance, operating, or repair instructions pertinent to all possible situations. If you require additional information, please contact the **Auto Crane** Company at the following telephone number: **(918) 836-0463**. The information contained in the manual is in effect at the time of this printing. Auto Crane Company reserves the right to update this material without notice or obligation.

# **--- IMPORTANT ---**

## **OPERATING PRACTICES & WARNINGS**

1. Make certain the vehicle meets minimum chassis requirements. (These requirements do not guarantee unit stability)
2. Make certain the crane is installed per factory specifications. Contact your local Distributor or the Auto Crane factory if any questions arise.
3. Keep the vehicle in as level a position as possible while loading or unloading.
4. **ALWAYS** set the vehicle emergency brake before beginning crane operations.
5. **ALWAYS** use outriggers from vehicle to the ground during crane operation. Make sure they are firmly positioned on solid footings.
6. All load ratings are based on crane capacity, **NOT** truck/crane stability.
7. Keep objects and personnel clear of crane path during operation.
8. Keep hoist cable pulled tight at all times.
9. **REMEMBER**, in lifting a heavy load, the weight can create enough tipping momentum to overturn the vehicle.
10. **ALWAYS** keep load as close to ground as possible.
11. Oil gears as required.
12. Periodic adjustment of hoist worm brake may be required (see automatic safety brake drawing in this manual).
13. Hydraulic hoses need to be inspected frequently for signs of deterioration, and be replaced as required.
14. The hoist hook is an important item that an operator should consider and use properly. It should be checked on a daily basis for distortion or cracks.
15. **ALWAYS** store outriggers before road travel.
16. **WARNING! NEVER OPERATE THE CRANE NEAR ELECTRICAL POWER LINES!** Death or serious injury will result from boom, line, or load contacting electric lines. Do not use crane within 10 feet (3.05m) of electric power lines carrying up to 50,000 volts. One foot additional clearance is required for every additional 30,000 volts or less.
17. **WARNING! NEVER EXCEED** load chart capacities (centerline of rotation to hoist hook).
18. **WARNING! NEVER** un-reel last 5 wraps of cable from drum!
19. **WARNING! NEVER** wrap cable around load!
20. **WARNING! NEVER** attempt to lift or drag a load from the side! The boom can fail far below its rated capacity.
21. **WARNING! NEVER** weld, modify, or use unauthorized components on any Auto Crane unit! This will void any warranty or liability. Also failure of the crane may result.
22. **WARNING! NEVER** place a chain link on the tip of the hook and try to lift a load!
23. **WARNING! NEVER** use a sling bar or anything larger than the hook throat that could prevent the hook latch from closing, thus negating the safety feature!
24. **WARNING!** In using a hook with latch, **ALWAYS** insure that the hook throat is closed before lifting a load! Proper attention and common sense applied to the use of the hoist hook and various slings will prevent possible damage to material being hoisted and may prevent injury to personnel.
25. **WARNING! NEVER** hold any pendant Select Switch on that will cause unsafe operating conditions!

## **WARNING!**

**Auto Crane Company remote controlled, stiff boom cranes are not designed or intended to be used for any applications involving the lifting or moving of personnel.**

# SAFETY DECAL SECTION

## 6006EH

**PART NO.:** 040517  
**DECAL:** STAY CLEAR OF BOOM  
**FUNCTION:** To inform the operator of the hazard of proximity or contact with the crane boom during operation.  
**USED ON:** All cranes  
**QUANTITY:** 4  
**PLACEMENT:** Both sides of outer and manual booms



**PART NO.:** 040518  
**DECAL:** STAY CLEAR OF LOAD  
**FUNCTION:** To inform the operator of the hazard of proximity or contact with the crane load during operation.  
**USED ON:** All cranes  
**QUANTITY:** 1  
**PLACEMENT:** Hoist hook

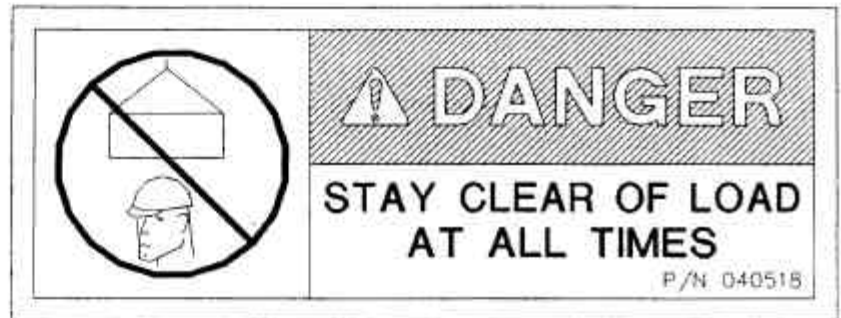

**PART NO.:** 040519  
**DECAL:** SCISSORS POINT  
**FUNCTION:** To inform the operator of possible danger at scissors point on crane.

**USED ON:** Articulated Cranes  
**QUANTITY:** 2  
**PLACEMENT:** Lift cylinder

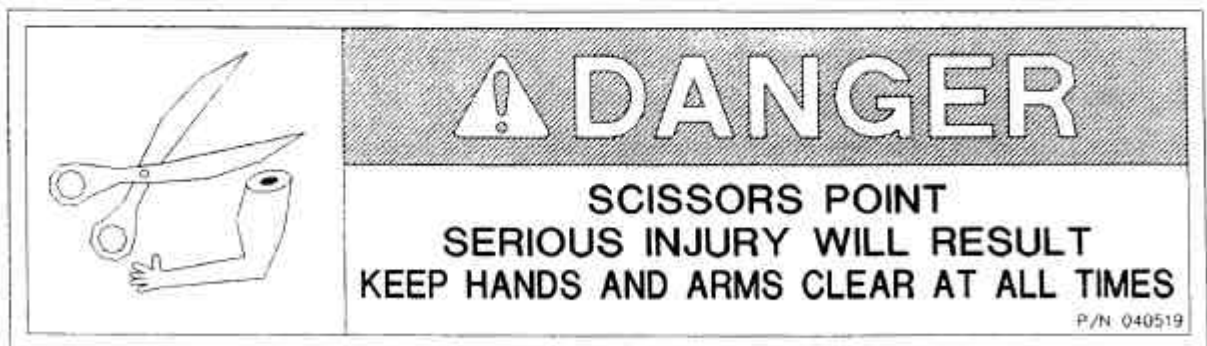

# SAFETY DECAL SECTION

## 6006EH

PART NO.: 040529

DECAL: ELECTROCUTION  
HAZARD

FUNCTION: To inform the operator of the hazard involved with contacting electrical power lines with crane boom.

USED ON: Articulated Cranes

QUANTITY: 2

PLACEMENT: Both control handle plates

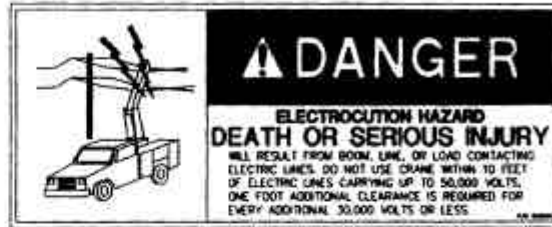

PART NO.: 040579

DECAL: OPERATION  
INSTRUCTIONS

FUNCTION: To inform the operator of the proper procedure to follow for safe operation of the crane.

USED ON: All Cranes

QUANTITY: 2

PLACEMENT: Both control handle plates

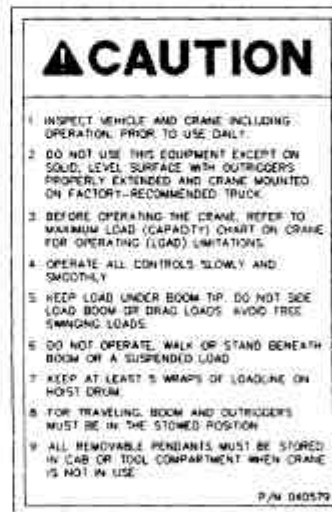

PART NO.: 040580

DECAL: OPERATOR TRAINING

FUNCTION: To inform the operator of the need to receive proper training before using the crane.

USED ON: All Cranes

QUANTITY: 2

PLACEMENT: Both control handle plates





# SAFETY DECAL SECTION

## 6006EH

**PART NO.:** 759016  
**DECAL:** EXTEND OUTRIGGERS  
**FUNCTION:** To inform operator that the outriggers must be extended and pinned in place before operating the crane.  
**USED ON:** All articulated Cranes  
**QUANTITY:** 2  
**PLACEMENT:** Both ends of outrigger tube



**PART NO.:** 759017  
**DECAL:** STAND CLEAR  
**FUNCTION:** Inform operator to stand clear of outriggers  
**USED ON:** All articulating cranes  
**QUANTITY:** 2  
**PLACEMENT:** Top of both outrigger legs



# SAFETY DECAL SECTION

## 6006EH

**PART NO.:** 040587  
**DECAL:** LOAD SENSOR  
**FUNCTION:** To inform operator NOT to tamper with factory pre-set load sensor.  
**USED ON:** CYLINDER  
**QUANTITY:** 1  
**PLACEMENT:** On cylinder right side.



**PART NO.:** 040632  
**DECAL:** CYLINDER OPERATION  
**FUNCTION:** To inform operator NOT to tamper with overload device.  
**USED ON:** CYLINDER  
**QUANTITY:** 1  
**PLACEMENT:** On cylinder left side.



## **--- IMPORTANT --- OPERATION OF UNIT**

1. Make sure this manual has been thoroughly read by all crane operating personnel and supervisors.
2. A routine inspection of the crane should be mandatory before each operating day. Any defects should be corrected immediately.
3. At a job site the vehicle should be positioned so that the crane can adequately reach the load within the rated capacity (centerline of rotation to hoist hook).
4. Keep the vehicle as level as possible during operation.
5. For electric cranes, **engage emergency brake** and leave ignition on with transmission in neutral (or in park for automatic transmissions). Activate any crane power switches. For Auto Crane units requiring battery and hydraulic operation, **engage emergency brake**, place gear selector in neutral, press clutch, activate PTO, release clutch and after hydraulic fluid is warm, set throttle control to proper engine speed.
6. Always use outriggers from the truck to the ground. Be sure these are firm and adequately positioned. When rotating, **keep load as low to the ground as possible**.
7. Remove pendant control from cab or storage area. On smaller units, plug pendant into receptacle on crane. On larger units, remove pendant control from guard and unwrap cable from boom. Do not operate crane until cable is unwound completely. On all cranes, detach hook from dead man. Crane is now ready for operation.
8. Always boom up before rotating so the boom will clear the required boom support.
9. When extending the boom, always maintain clearance between the boom crown and the traveling block or hoist hook.
10. Always observe safe and practical operation to avoid possible accidents. Refer to Safety Tips and Precautions.
11. After completing lifting operations, return the boom to stowed position on the boom support. Avoid unneeded pressure on the boom support.
12. Store pendant control on proper location (in cab or on crane).
13. Return outriggers to stowed position. Make sure they are pinned in place or jacklegs are returned to compartment.
14. Check work area for any tools or equipment not stored.
15. Release throttle control, depress clutch and disengage PTO. Deactivate any crane power switches.
16. Report any unusual occurrence during crane operation that may indicate required maintenance or repair.
17. **NEVER** use two cranes to support a load too large for either crane.
18. Spray all electrical equipment with special corrosion resistant coating. This eliminates rust or corrosion due to melting and freezing action of condensation.

## **OPERATION OF OUTRIGGERS**

For hydraulic outriggers:

1. Shift crane/outrigger control valve to "outrigger" position.
2. While operating the outrigger control valves (located on the outrigger cylinders) simultaneously operate the boom-up control switch. This will allow the hydraulic system to build pressure.
3. After outriggers are positioned, return crane/outrigger selector to "crane" position.
4. Crane is now ready to operate.

For manual outriggers:

1. Pull lock pins to release jack leg or drop down outrigger and move to outermost lock position.
2. Make sure lock pins are reinstalled properly.
3. Lower outrigger pad to firm ground and adjust foot to take out slack.
4. Crane is now ready to operate.

# ***QUALIFICATIONS FOR AND CONDUCT OF OPERATORS AND OPERATING PRACTICES***

## **OPERATORS**

- 1 Crane operation shall be limited to personnel with the following minimum qualifications:**
  - A. designated persons
  - B. trainees under the direct supervision of a designated person
  - C. maintenance and test personnel (when it is necessary in the performance of their duties)
  - D. inspectors (crane).
- 2 No one other than the personnel specified above shall enter the operating area of a crane with the exception of persons such as oilers, supervisors, and those specified persons authorized by supervisors whose duties require them to do so and then only in the performance of their duties and with the knowledge of the operator or other persons.**

## **QUALIFICATIONS FOR OPERATORS**

- 3 Operators shall be required by the employer to pass a practical operating examination. Qualifications shall be limited to the specific type of equipment for which examined.**
- 4 Operators and operator trainees shall meet the following physical qualifications:**
  - A. Vision of at least 20/30 Snellen in one eye and 20/50 in the other, with or without corrective lenses.
  - B. Ability to distinguish colors, regardless of position, if colors differentiation is required for operation.
  - C. Adequate hearing with or without hearing aid for the specific operation.
- 5 Evidence of physical defects or emotional instability which render a hazard to operator or others, which in the opinion of the examiner could interfere with the operator's performance may be sufficient cause for disqualification. In such cases, specialized clinical or medical judgment and tests may be required.**
- 6 Evidence that the operator is subject to seizures or loss of physical control shall be sufficient reason for disqualification. Specialized medical tests may be required to determine these conditions.**

- 7 Operators and operator trainees should have normal depth perception, coordination, and no tendencies to dizziness or similar undesirable characteristics.**
- 8 In addition to the above listed requirements, the operator shall:**
  - A. Demonstrate the ability to comprehend and interpret all labels, operator's manuals, safety codes and other information pertinent to correct crane operations.
  - B. Possess knowledge of emergency procedures and implementation of same.
  - C. Demonstrate to the employer the ability to operate the specific type of equipment.
  - D. Be familiar with the applicable safety regulations.
  - E. Understand responsibility for maintenance requirements of crane.
  - F. Be thoroughly familiar with the crane and its control functions.
  - G. Understand the operating procedures as outlined by the manufacturer.

## **CONDUCT OF OPERATORS**

- 9 The operator shall not engage in any practice which will divert his attention while actually operating the crane.**
- 10 Each operator shall be responsible for those operations under the operator's direct control. Whenever there is any doubt as to safety, the operator shall consult with the supervisor before handling the loads.**
- 11 The operator should not leave a suspended load unattended unless specific precautions have been instituted and are in place.**
- 12 If there is a warning sign on the switch or engine starting controls, the operator shall not close the switch or start the engine until the warning sign has been removed by the appointed person.**
- 13 Before closing the switch or starting the engine, the operator shall see that all controls are in the "OFF" or neutral position and all personnel are in the clear.**
- 14 If power fails during operation, the operator shall:**
  - A. move power controls to the "OFF" or neutral position.

# ***QUALIFICATIONS FOR AND CONDUCT OF OPERATORS AND OPERATING PRACTICES***

B. land the suspended load and boom, if practical.

**15 The operator shall be familiar with the equipment and its proper care. If adjustments or repairs are necessary, the operator shall report the same promptly to the appointed person, and shall also notify the next operator.**

**16 All controls shall be tested by the operator at the start of each shift. If any controls do not operate properly, they shall be adjusted or repaired before operations are begun.**

**17 Stabilizers shall be visible to the operator while extending or setting unless operator is assisted by a signal person.**

## **OPERATING PRACTICES**

### **HANDLING THE LOAD**

#### **18 Size of load**

- A. No crane shall be loaded beyond the rated load except for test purposes.
- B. The load to be lifted is to be within the rated load of the crane and its existing configuration.
- C. When loads which are not accurately known are to be lifted, the person responsible for the job shall ascertain that the weight of the load does not exceed the crane rated load at the radius at which the load is to be lifted.

#### **19 Attaching the load**

- A. The load shall be attached to the hook by means of slings or other devices of sufficient capacity.
- B. Hoist rope shall not be wrapped around the load.

#### **20 Moving the load**

- A. The operator shall determine that:
- B. The crane is level and, where necessary, the vehicle/carrier is blocked properly.
- C. The load is well secured and balanced in the sling or lifting device before it is lifted more than a few inches.
- D. Means are provided to hold the vehicle stationary while operating the crane.
- E. Before starting to lift, the hook shall be brought over the load in such a manner as to minimize swinging.

F. During lifting care shall be taken that:

- 1. there is no sudden acceleration or deceleration of the moving load.**
- 2. load, boom or other parts of the crane do not contact any obstruction.**

G. Cranes shall not be used for dragging loads sideways.

H. This standard recognizes that articulating boom cranes are designed and intended for handling materials. They do not meet personnel lift or elevator requirements. Therefore, no lifting, lowering, swinging or traveling shall be done while a person is on the hook or load. Hook attached suspended work platforms (baskets) shall not be used with cranes covered by this standard. Work platforms attached to the boom must be approved by crane manufacturer.

I. The operator should avoid carrying loads over people.

J. When the crane is so equipped, the stabilizers shall be fully extended and set. Blocking under stabilizers shall meet the requirements as follows:

- 1. strong enough to prevent crushing.**
- 2. of such thickness, width and length as to completely support the stabilizer pad.**

K. Firm footing under all tires, or individual stabilizer pads should be level. Where such a footing is not otherwise supplied, it should be provided by timbers, cribbing, or other structural members to distribute the load so as to not exceed allowable bearing capacity or the underlying material.

L. In transit, the boom shall be carried in stowed position.

M. When rotating the crane, sudden starts and stops shall be avoided. rotational speed shall be such that the load does not swing out beyond the radius at which it can be controlled.

N. The crane shall not be transported with a load on the hook unless recommended by the manufacturer.

O. No person should be permitted to stand or pass under a suspended load.

**21 Stowing procedure. Follow the manufacturer's procedure and sequence when stowing and un-stowing the crane.**

# **QUALIFICATIONS FOR AND CONDUCT OF OPERATORS AND OPERATING PRACTICES**

## **MISCELLANEOUS**

### **OPERATING NEAR ELECTRICAL POWER LINES**

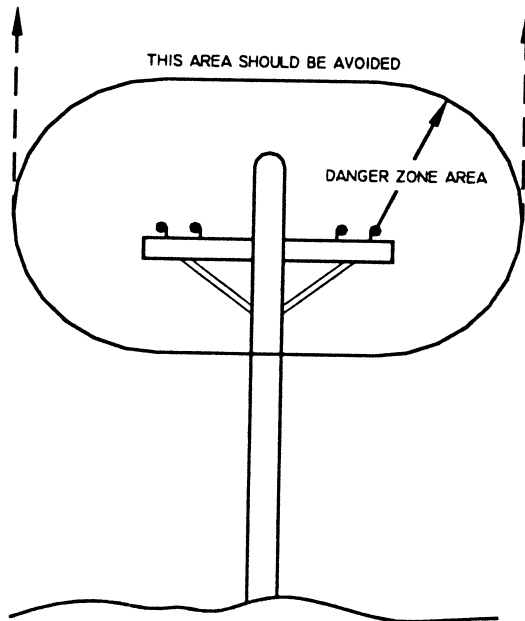

**22 Cranes shall be operated so that no part of the crane or load enters into the danger zone shown above.**

#### **EXCEPTIONS**

- A. The danger zone may be entered after confirmation by an appointed person that the electrical distribution and transmission lines have been de-energized and visibly grounded at the point of work; or
- B. The danger zone may be entered if insulating barriers (not a part of nor an attachment to the crane) have been erected to prevent physical contact with the lines.

**23 For lines rated 50 kV or below, minimum clearance between the lines and any part of the crane or load (including handling appendages) shall be 10 ft. (3m). For higher voltages, see Table 1.**

**24 Caution shall be exercised when working near overhead lines, because they can move horizontally or vertically due to wind, moving the danger zone to new positions.**

**25 In transit with no load and boom lowered the clearance shall be specified in Table 1.**

**26 A qualified signalperson shall be assigned to observe the clearance and give warning before approaching the above limits.**

- A. Any overhead wire shall be considered to be an energized line unless and until the person owning such line or the electrical utility authorities verify that it is not an energized line.
- B. Exceptions to this procedure, if approved by the administrative or regulatory authority if the alternate procedure provides equivalent protection and set forth in writing.
- C. Durable signs shall be installed at the operator's station and on the outside of the crane, warning that electrocution or serious bodily injury may occur unless a minimum clearance of 10 ft. (3.0m) between the crane or the load being handled and energized power lines. Greater clearances are required because of higher voltage as stated above. These signs shall be revised but not removed when local jurisdiction requires greater clearances.

**TABLE 1**

normal voltage, kV (phase to phase)		minimum required clearance	
		ft	(m)
<b><u>when operating near high voltage power lines</u></b>			
over	to 50	10	(3.05)
over	50 to 200	15	(4.6)
over	200 to 350	20	(6.1)
over	350 to 500	25	(7.62)
over	500 to 750	35	(10.67)
over	750 to 1000	45	(13.72)
<b><u>while in transit with no load and boom lowered</u></b>			
over	to 0.75	4	(1.22)
over	0.75 to 50	6	(1.83)
over	50 to 345	10	(3.83)
over	345 to 750	16	(4.87)
over	750 to 1000	20	(6.1)

# ***INSPECTION, TESTING AND MAINTENANCE***

## **GENERAL**

### **INSPECTION CLASSIFICATION**

**27 Initial inspection.** Prior to initial use, all new, altered, modified or extensively repaired cranes shall be inspected by a designated person to insure compliance with provisions of this standard.

**28 Regular inspection.** Inspection procedure for cranes in regular service is divided into two general classifications based upon the intervals at which inspection should be performed. The intervals in turn are dependent upon the nature of the components of the crane and the degree of their exposure to wear, deterioration, or malfunction. The two general classifications are herein designated as "frequent" and "periodic" with respective intervals between inspections as defined below.

- A. frequent inspection - daily to monthly intervals
- B. periodic inspection - one to twelve intervals, or as specifically recommended by the manufacturer

### **FREQUENT INSPECTION**

**29 Inspection shall be performed by designated personnel.**

- A. control mechanisms for maladjustment interfering with proper operation - daily, when used
- B. control mechanisms for excessive wear of components and contamination by lubricants or other foreign matter
- C. safety devices for malfunction
- D. all hydraulic hoses, particularly those which flex in normal operation of crane functions, should be visually inspected once every working day, when used
- E. hooks and latches for deformation, chemical damage, cracks, and wear. Refer to ANSI/ASME B30.10
- F. rope reeving for compliance with crane manufacturer's specifications, if optional winch is used

G. electrical apparatus for malfunctioning, signs of excessive deterioration, dirt and moisture accumulation

H. hydraulic system for proper oil level and leaks daily

I. tires for recommended inflation pressure, cuts and loose wheel nuts

J. connecting pins and locking device for wear and damage

### **PERIODIC INSPECTION**

**30 Deformed, cracked or corroded members in the crane structure and carrier.**

**31 Loose bolts, particularly mounting bolts.**

**32 Cracked or worn sheaves and drums.**

**33 Worn, cracked, or distorted parts such as pins, bearings, shafts, gears, rollers and devices.**

**34 Excessive wear on brake and clutch system parts and lining.**

**35 Crane hooks inspected for cracks.**

**36 Travel steering, braking, and locking devices, for malfunction.**

**37 Excessively worn or damaged tires.**

**38 Hydraulic and pneumatic hose, fittings, and tubing inspection.**

A. evidence of leakage at the surface of the flexible hose or its junction with metal and coupling

B. blistering, or abnormal deformation to the outer covering of the hydraulic or pneumatic hose

C. leakage at threaded or clamped joints that cannot be eliminated by normal tightening or recommended procedures

D. evidence or excessive abrasion or scrubbing on the outer surface of a hose, rigid tube, or fitting. Means shall be taken to eliminate the interference of

# ***INSPECTION, TESTING AND MAINTENANCE***

## **GENERAL**

elements in contact or otherwise protect the components

necessary to determine origin of the problem before corrective action can be taken.

### **39 Hydraulic and pneumatic pumps and motors inspection.**

- A. loose bolts or fasteners
- B. leaks at joints between sections
- C. shaft seal leaks
- D. unusual noises or vibrations
- E. loss of operating speed
- F. excessive heating of the fluid
- G. loss of pressure

### **40 Hydraulic and pneumatic valves inspection.**

- A. cracks in valve housing
- B. improper return of spool to neutral position
- C. leaks at spools or joints
- D. sticking spools
- E. failure of relief valves to attain or maintain correct pressure setting
- F. relief valve pressure shall be checked as specified by the manufacturers

### **41 Hydraulic and pneumatic cylinders inspection.**

- A. drifting caused by fluid leaking across piston
- B. rod seals leaking
- C. leaks at welding joints
- D. scored, nicked, or dented cylinder rods
- E. damaged case (barrel)
- F. loose or deformed rod eyes or connecting joints

**42 Hydraulic filters. Evidence of rubber particles on the filter elements may indicate hose, "O" ring, or other rubber component deterioration. Metal chips or pieces on the filter may denote failure in pumps, motors, or cylinders. Further checking will be**

**43 Labels are to be in place and legible.**

### **CRANES NOT IN REGULAR USE**

**44 A crane which has been idle for a period of over one month or more, but not less than six months, shall be given an inspection conforming with the initial-regular- frequent inspections.**

**45 A crane which has been idle for a period of over six months shall be given a complete inspection conforming with the initial-regular-frequent inspection requirements.**

### **INSPECTION RECORDS**

**46 Dated records for periodic inspection should be made on critical items such as brakes, crane hooks, rope, hydraulic and pneumatic cylinders, and hydraulic and pneumatic relief pressure valves. Records should be kept available to an appointed person.**

### **OPERATIONAL TESTS**

**47 Prior to initial use, all new, altered, modified, or extensively repaired cranes shall be tested for compliance with the operational requirements of this section, including functions such as the following:**

- A. load lifting and lowering mechanisms
- B. boom lifting and lowering mechanisms
- C. boom extension and retraction mechanisms
- D. swing mechanisms
- E. safety devices
- F. operating controls comply with appropriate function labels

***Operational crane test results shall be made available to an appointed person.***

### **RATED TEST LOAD**

***Prior to initial use, altered, modified, or extensively repaired cranes shall be load***



# ***INSPECTION, TESTING AND MAINTENANCE***

## **GENERAL**

***tested by or under the direction of an appointed person.***

**48 Test loads shall not exceed 110% of the manufacturer's load ratings.**

**49 Written reports shall be maintained showing test procedures and confirming the adequacy of repairs.**

## **MAINTENANCE**

### **PREVENTIVE MAINTENANCE**

**50 Before adjustment and repairs are started on a crane, the following precautions shall be taken as applicable:**

- A. crane placed where it will cause the least interference with other equipment or operations
- B. all controls at the "off" position
- C. starting means rendered inoperative
- D. boom lowered to the ground if possible or otherwise secured against dropping
- E. relieve hydraulic oil pressure from all hydraulic circuits before loosening or removing hydraulic components

**51 Warning or "OUT OF ORDER" signs shall be placed on the crane controls.**

**52 After adjustments and repairs have been made, the crane shall not be returned to service until all guards have been reinstalled, trapped air removed from hydraulic system (if required), safety devices reactivated, and maintenance equipment removed.**

### **ADJUSTMENTS AND REPAIRS**

**53 Any hazardous conditions disclosed by the inspection requirements shall be corrected before operation of crane is resumed, Adjustments and repairs shall be done only by designated personnel.**

**54 Adjustments shall be maintained to assure correct functioning of components, The following are examples:**

- A. functional operating mechanism
- B. safety devices
- C. control systems

**55 Repairs or replacements shall be provided as needed for operation.**

***The following are examples:***

- A. critical parts of functional operating mechanisms which are cracked, broken, corroded, bent, or excessively worn
- B. critical parts of the crane structure which are cracked, bent, broken, or excessively corroded
- C. crane hooks showing cracks, damage, or corrosion shall be taken out of service. Repairs by welding are not recommended

**56 Instructions shall be provided by the manufacturer for the removal of air from hydraulic circuits.**

## **LUBRICATION**

***All moving parts of the crane, for which lubrication is specified, should be regularly lubricated per the manufacturer's recommendations and procedures.***

## **ROPE INSPECTION**

**57 Frequent Inspection**

- A. All running ropes in service should be visually inspected once each working day. A visual inspection shall consist of observation of all rope which can be in use during the days operations. These visual observations should be considered with discovering gross damage such as listed below, which may be an immediate hazard.

- 1. distortion of the rope such as kinking, crushing, un-stranding, birdcaging, main strand displacement, or core protrusion. Loss of rope diameter in a short length or unevenness of outer strands should be replaced**

- 2. general corrosion**

# ***INSPECTION, TESTING AND MAINTENANCE***

## **GENERAL**

3. broken or cut strands;
4. number, distribution and type of visible broken wires. When such damage is discovered, the rope shall either be removed from service or given as inspection.

B. Care shall be taken when inspecting sections of rapid deterioration such as flange points, crossover points, and repetitive pickup points on drums.

### **58 Periodic inspection**

A. The inspection frequency shall be determined by a qualified person and shall be based on such factors as:

1. expected rope life as determined by experience on the particular installation or similar installations
2. severity of environment
3. percentage of capacity lifts
4. frequency rates of operation
5. exposure to shock loads

***Inspection need not be at equal calendar intervals and should be more frequent as the rope approaches the end of its service life. This inspection shall be made at least annually.***

- B. Periodic inspection shall be performed by a designated person. This inspection shall cover the entire length of the rope. Only the surface wires need be inspected. No attempt should be made to open the rope. Any deterioration results in appreciable loss of original strength, such as described below, shall be noted and determination made as to whether use of the rope would constitute a hazard: points listed above reduction of rope diameter below nominal diameter due to loss of core support, internal or external corrosion, or wear of outside wires; severely corroded, cracked, bent, worn or improperly applied connections;
- C. Care shall be taken when inspecting sections subject to rapid deterioration such as the following:

1. sections in contact with saddles, equalizer sheaves, or other sheaves where rope travel is limited
2. sections of the rope at or near terminal ends where corroded or broken wires may protrude

### **ROPE REPLACEMENT**

59 No precise rules can be given for determination of the exact time for replacement of rope, since many variable factors are involved.

***Continued use in this respect depends upon good judgement by a designated person in evaluating remaining strength in a used rope after allowance for deterioration disclosed by inspection. Continued rope operation depends upon this remaining strength.***

60 Conditions such as the following shall be reason for questioning continued use of the rope or increasing the frequency of inspection:

- A. in running ropes, six randomly distributed broken wires in one lay or three broken wires in one strand in one lay
- B. one outer wire broken at the contact point with the core of the rope structure and protrudes or loops out of the rope structure. Additional inspection of this section is required
- C. wear of one third of the original diameter of the outside individual wire
- D. kinking, crushing, birdcaging, or any other damage resulting in distortion of the rope structure
- E. evidence of any heat damage from any cause
- F. reduction from nominal diameter of more than 1/64 in. (0.4mm) for diameters up to and including 5/16 in. (8 mm), 1/32 in. (0.8 mm) for diameter 3/8 in. (9.5 mm) to and including 1/2 in. (13 mm), 3/64 in. (1.2 mm) for diameter 9/16 in. (14.5 mm) to and including 3/4 in. (19 mm). 1/16 in. (1.6 mm) for diameter 7/8 in. (22 mm) to and including 11/8 in. (29 mm), 3/32 in. (2.4 mm) for diameters 11/4 in. (32 mm) to and including 11/2 in. (38 mm)

# ***INSPECTION, TESTING AND MAINTENANCE***

## **GENERAL**

G. In standing ropes, more than two broken wires in one lay in sections beyond end connections or more than one broken wire at an end connection.

H. Replacement rope shall have a strength rating at least as great as the original rope furnished or recommended by the crane manufacturer. Any deviation from the original size, grade, or construction shall be specified by a rope manufacturer, or a qualified person.

**61 Rope not in regular use:** all rope which has been idle for a period of a month or more due to shutdown or storage of a crane on which it is installed, shall be given an inspection in accordance with above information before it is placed in service. This inspection shall be for all types of deterioration and shall be performed by a qualified person.

### **62 Inspection records**

A. frequent inspection- no records required

B. periodic inspections- in order to establish data as a basis for judging the proper time for replacement, a dated report condition at each periodic inspection should be kept on file. This report shall cover points of deterioration listed above.

### **ROPE MAINTENANCE**

**63 Rope should be stored to prevent damage or deterioration.**

**64 Unreeling or uncoiling of rope shall be done as recommended by the rope manufacturer and with care to avoid kinking or inducing twist.**

**65 Before cutting a rope, seizing shall be placed on each side of the place where the rope is to be cut to prevent unlaying of the strands. On pre-formed rope, one seizing on each side of the cut is required. On non-preformed ropes of 7/8 in. (22 mm) diameter or smaller, two seizings on each side of the cut are required, and for non-preformed rope 1 in. (25 mm) diameter or larger, three seizings on each side of the cut are required.**

**66 During installation care should be exercised to avoid dragging of the rope in the dirt or around objects which will scrape, nick crush or induce sharp bends in it.**

**67 Rope should be maintained in a well-lubricated condition. It is important that lubricant applied as a part of a maintenance program shall be compatible with the original lubricant and to this end the rope manufacturer should be consulted. Lubricant applied shall be the type which does not hinder visual inspection. Those sections of rope which are located over sheaves or otherwise hidden during inspection and maintenance procedures require special attention when lubricating rope. The object of rope lubrication is to reduce internal friction and to prevent corrosion.**

**68 When an operating rope shows greater wear or well defined localized areas than on the remainder of the rope, rope life can be extended in cases where a section at the worn end, and thus shifting the wear to different areas of the rope.**

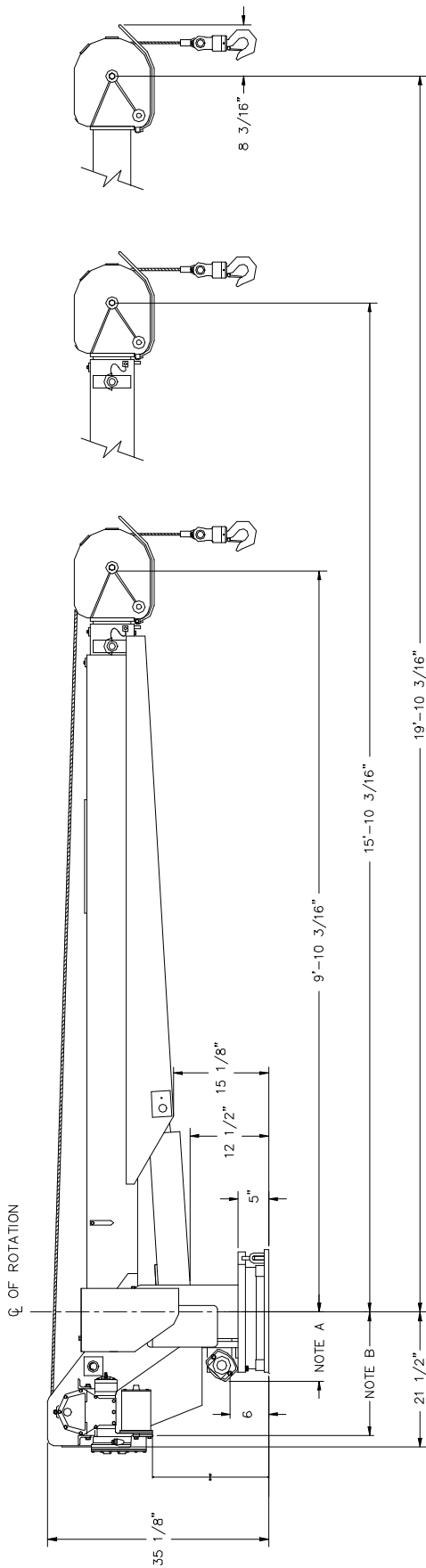

NOTES:

- A. MAX TURNING RADIUS AT ROTATION MOTOR = 14 1/2"
- B. MAX TURNING RADIUS AT HOIST ACTUATOR = 24 1/2"

SPECIFICATIONS:

- LENGTH: 12'-5"
- WIDTH: 22 1/2"
- HEIGHT: 35 1/8"
- BOOM LENGTH: 10'-4 3/4" (SINGLE LINE RETRACTED)
- BOOM EXTENSION
- POWER: 6'
- MANUAL: 4'
- TOTAL: 10'

- CRANE WEIGHT: APPROX. 1350 LBS.
- POWER SOURCE: 24 VOLT DC W/ HYD POWER UNIT
- REMOTE MOUNTED VOLTAGE SWITCHING UNIT AND PENDANT CONNECTION BOX
- 370° ROTATION
- HYD RELIEF SETTING: 2200 PSI
- MAX AMP DRAW FOR HOIST: APPROX. 140 AMPS
- MAX AMP DRAW FOR HYD UNIT: APPROX. 10 AMPS

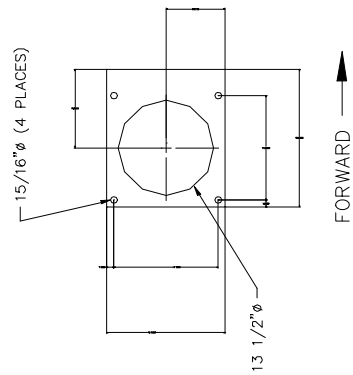

AW-385  
6006EH GENERAL DIMENSIONS AND SPECIFICATIONS

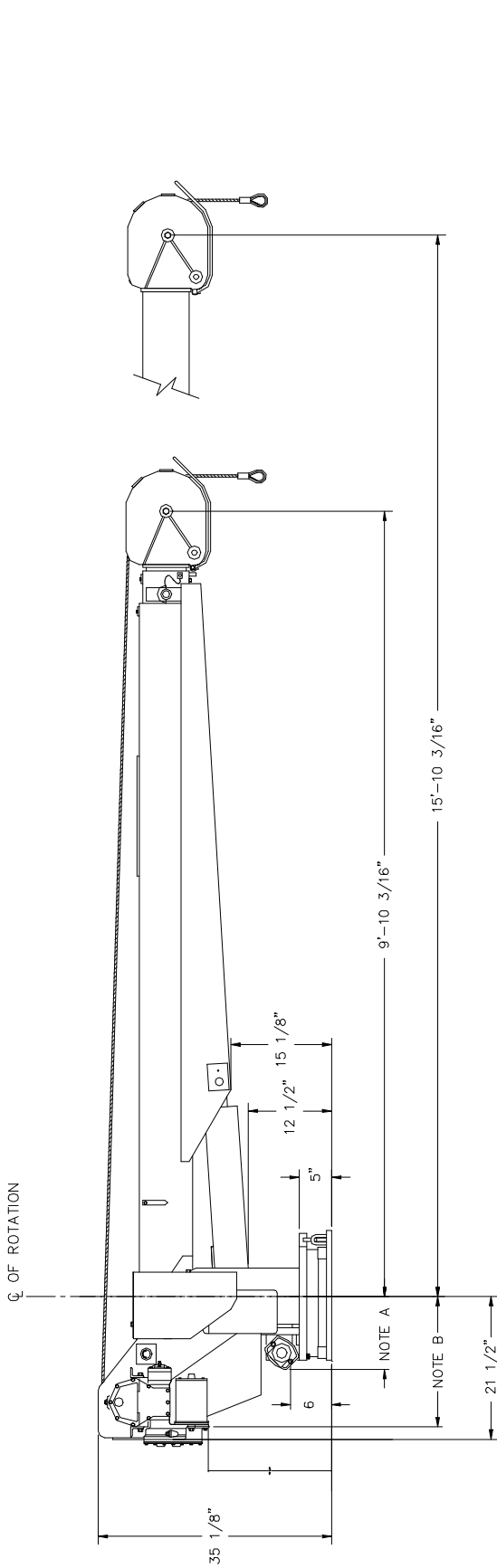

4-1.0.0

NOTES:

- A. MAX TURNING RADIUS AT ROTATION MOTOR = 14 1/2"
- B. MAX TURNING RADIUS AT HOIST ACTUATOR = 24 1/2"

SPECIFICATIONS:

- LENGTH: 15' 7/8"
- WIDTH: 22' 1/2"
- HEIGHT: 35' 1/8"
- BOOM LENGTH: 10'-2 5/8" (SINGLE LINE RETRACTED)
- BOOM EXTENSION: 6' POWER
- CRANE WEIGHT: APPROX. 1350 LBS.
- POWER SOURCE: 24 VOLT DC W/ HYD POWER UNIT
- REMOTE MOUNTED VOLTAGE SWITCHING UNIT AND PENDANT CONNECTION BOX
- 370° ROTATION
- HYD RELIEF SETTING: 2200 PSI
- MAX AMP DRAW FOR HOIST: APPROX. 140 AMPS
- MAX AMP DRAW FOR HYD UNIT: APPROX. 120 AMPS

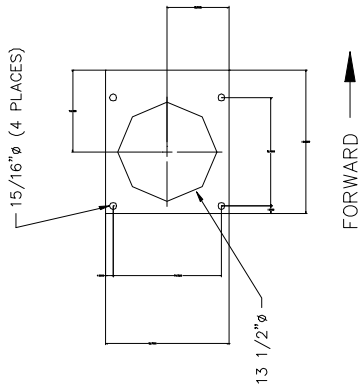

7/96

AW-386  
6006EH GENERAL DIMENSIONS AND SPECIFICATIONS  
(10-16 BOOM)

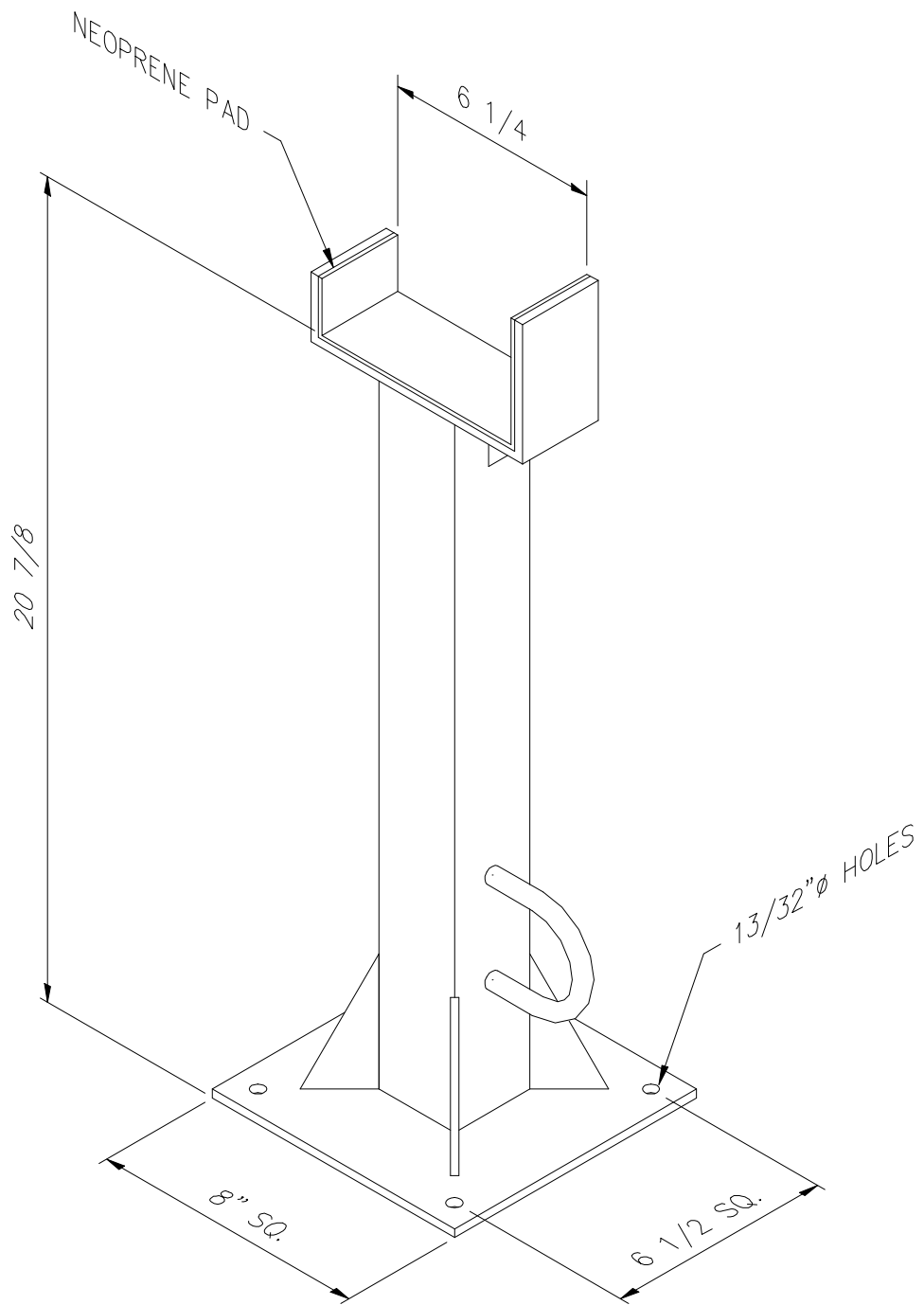

AW-384  
6006EH BOOM SUPPORT (P/N 726175)

# STABILIZER ASSEMBLY

P/N 360300

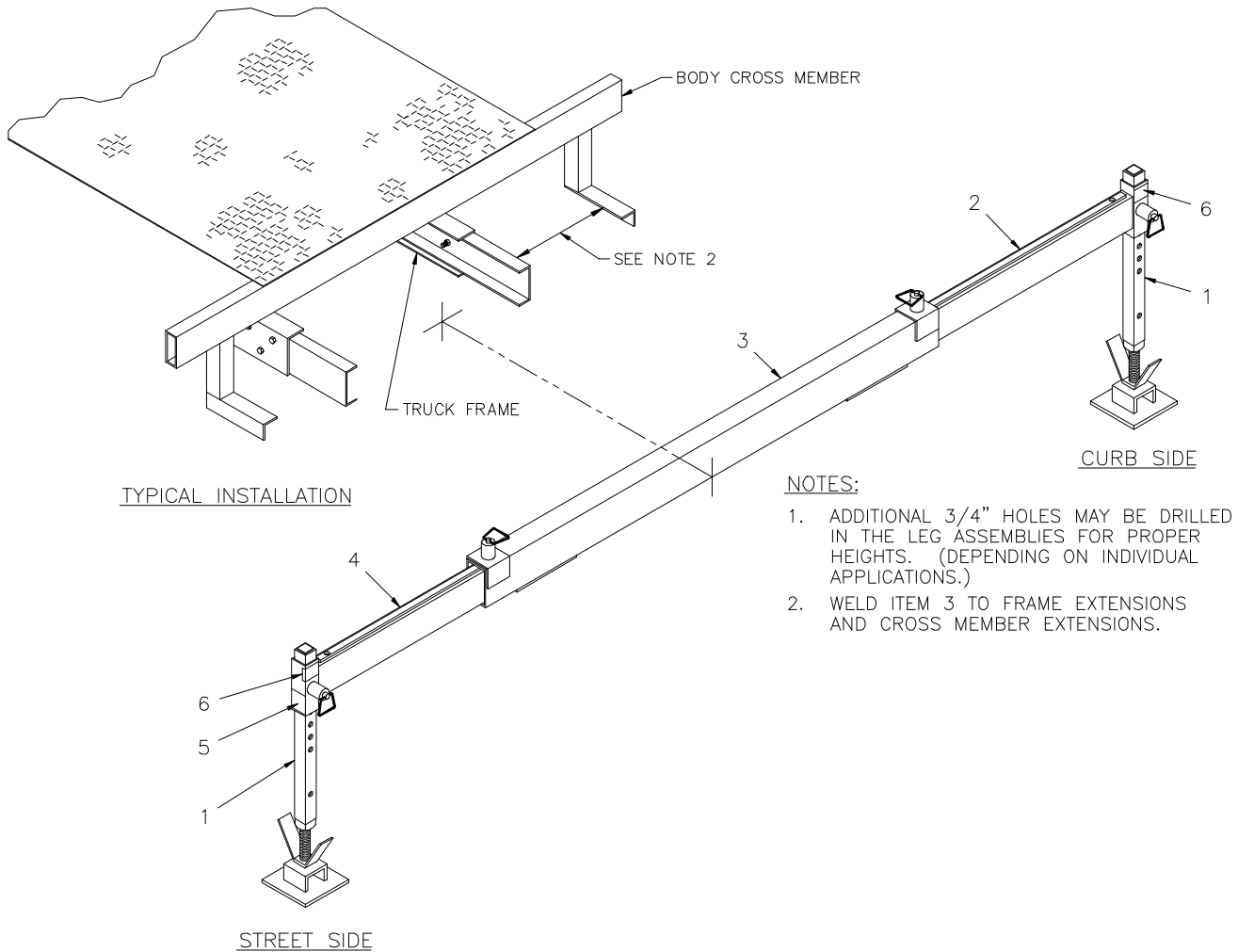

ITEM	QTY	P/N	DESCRIPTION
1	2	360301	LEG ASSEMBLY
2	1	360302	SOCKET / PULL PIN ASSEMBLY
3	1	360303-001	OR SOCKET / PULL PIN ASSEMBLY
4	1	360325	SOCKET / PULL PIN ASSEMBLY
5	2	040581	DANGER CRUSHING DECAL
6	2	759017	CAUTION DECAL

1. DRILL 13/16 DIAMETER HOLE IN COMPARTMENT FLOOR OR BACK WALL. INSTALL CABLE AND BUSHING (No.BB-50 FURNISHED ON CABLE) AS SHOWN. WRAP ELECTRICAL TAPE AROUND CABLE TO GIVE THE WIRE A SNUG FIT IN BUSHING.
2. RUN CABLE INSIDE CHASSIS FRAME TO STARTER SOLENOID BATTERY CONNECTION. LOCATE CABLE SO THAT IT WILL BE PROTECTED, AVOID SHARP EDGES. INSTALL THE NO.838 FRAME CLIPS TO HOLD CABLE SECURELY IN PLACE. IF SURPLUS CABLE EXISTS, THE CABLE CAN BE CUT OFF, AND EXTRA TERMINAL FURNISHED WITH CABLE INSTALLED.
3. REMOVE NUT ON SOLENOID BATTERY TERMINAL POST, INSTALL CRANE POWER CABLE, REPLACE NUT AND TIGHTEN.
4. IF THE BATTERY IS GROUNDED TO THE ENGINE, IT MAY BE NECESSARY TO ADD AN ADDITIONAL GROUND CABLE FROM THE ENGINE TO THE CHASSIS FRAME IN ORDER TO OBTAIN MAXIMUM POWER AT THE CRANE. THE CRANE SHOULD BE GROUNDED TO THE CHASSIS FRAME. THIS IS USUALLY ACCOMPLISHED THROUGH THE BODY MOUNTING BRACKET.

CAUTION:  
BOOM MUST BE PROPERLY SECURED  
IN PLACE, ON A BOOM SUPPORT  
BRACKET, WHEN CRANE IS NOT IN  
USE. (TO PREVENT GEAR DAMAGE)

BOOM SUPPORT BRACKET  
AUTO CRANE P/N 750585  
FOR 10-16-20 BOOM,

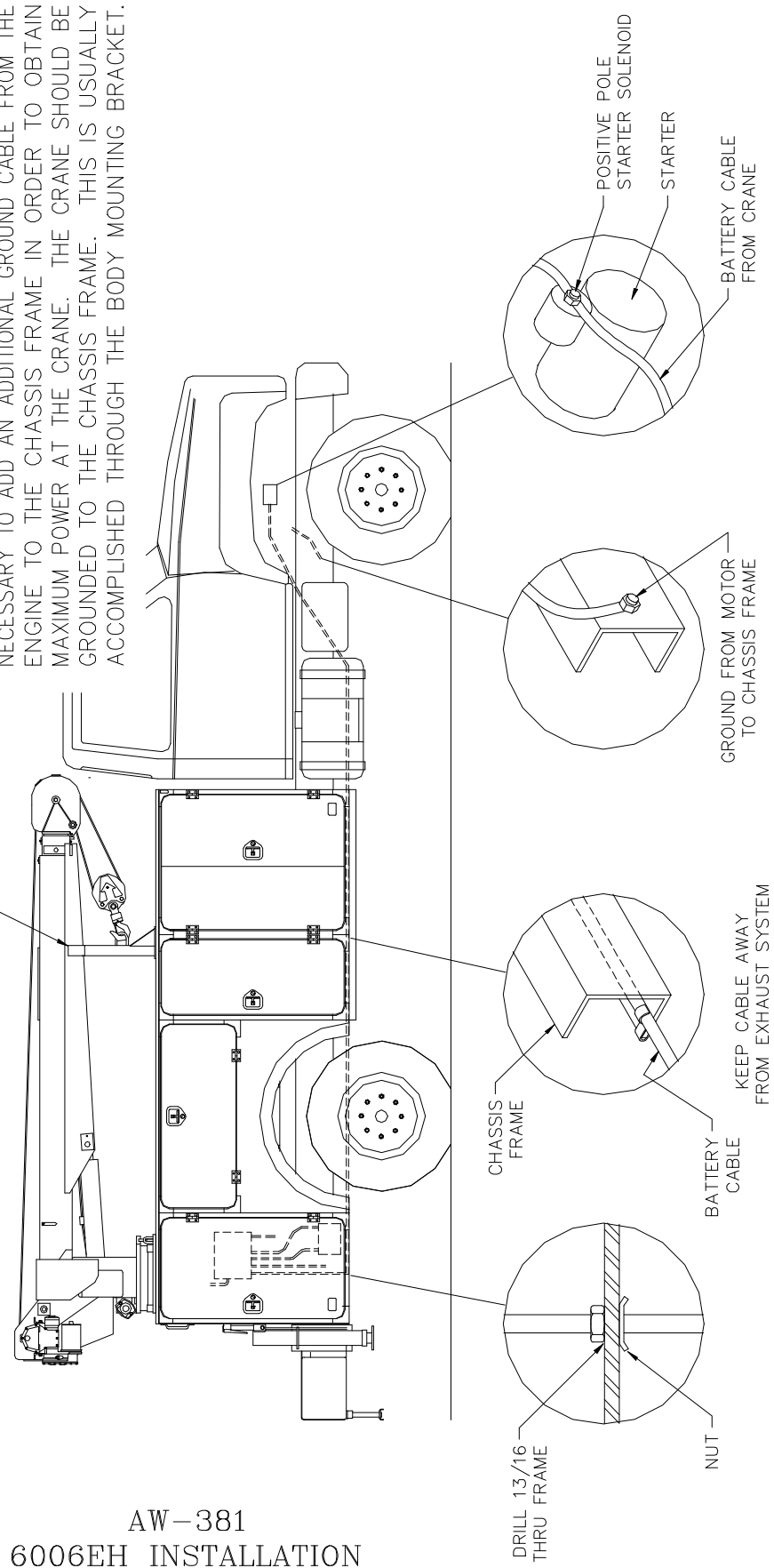

AW-381  
6006EH INSTALLATION



# INSTALLATION (CRANE COMPARTMENT)

## MODEL 6006EH

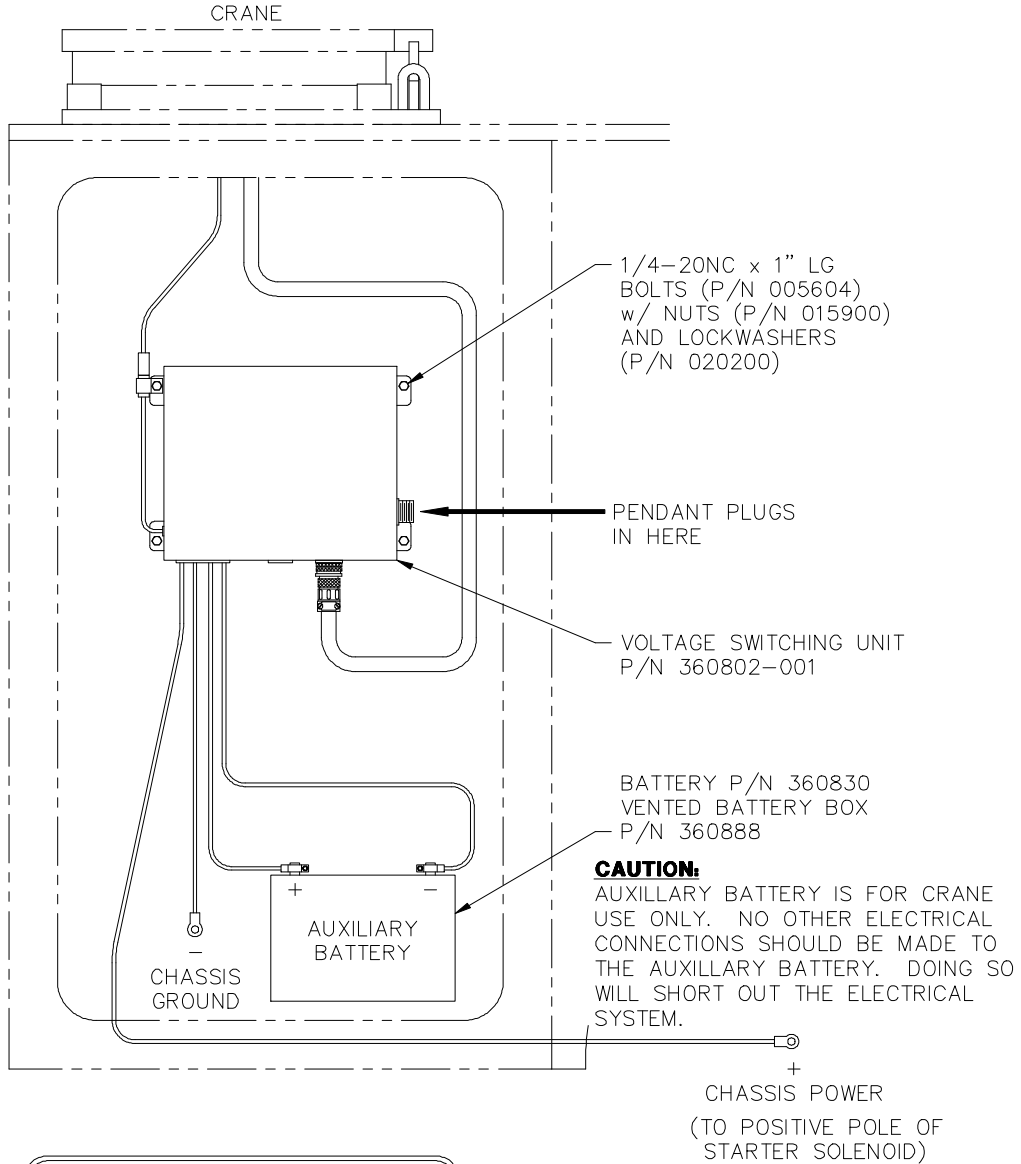

### NOTICE:

WE RECOMMEND REPLACING ANY NO-MAINTENANCE TRUCK BATTERY WITH A MAINTENANCE TYPE TRUCK BATTERY

### NOTE:

SEE ELECTRICAL SECTION FOR WIRING DIAGRAMS

# **LUBRICATION & MAINTENANCE SCHEDULE**

## **6006EH CRANE**

<b>SERVICE PERFORMED</b>	<b>DAY</b>	<b>WEEKLY</b>	<b>3 MOS</b>	<b>6 MOS</b>	<b>YEAR</b>	<b>NOTES</b>
LOAD HOOK	X					INSPECT HOOK & LATCH FOR DEFORMATION, CRACKS, & CORROSION
CABLE DRUM	X					MAKE SURE CABLE IS WOUND EVENLY ON DRUM
HOIST CABLE	X					CHECK FOR FLATTENING, KINKS, & BROKEN STRANDS, SEE MANUAL
HYD. HOSES	X					VISUAL INSPECTION
HYD. FLUID	X					CHECK FLUID LEVEL
MOUNTING BOLTS		X				CHECK-TORQUE TO 440 FT-LBS (DRY) AS REQUIRED
ROTATION RING GEAR		X				LUBE WITH MOBILETAC LL, OR LUBRI-PLATE P/N 15263, OR EQUAL
SHEAVE BEARINGS		X				SEALED BEARING, REPLACE IF ROUGH OR LOOSE
ALL OTHER BOLTS		X				CHECK-TIGHTEN AS REQUIRED
BOOM PIVOTS		X				GREASE WITH MOBILPLEX EP-2 OR EQUIVALENT @ ZERKS
BOOM CYLINDER		X				CHECK AROUND CYLINDER ROD FOR EXCESS FLUID LEAKAGE
BOOM CYLINDER PINS		X				GREASE WITH MOBILPLEX EP-2 OR EQUIVALENT @ ZERKS
EXTENSION DETENT PIN		X				LUBE DETENT SPRING & BALL W/ WD-40
ROTATION BEARING			X			GREASE WITH MOBILPLEX EP-2 OR EQUIVALENT @ ZERKS
ROTATION BEARING BOLTS			X			CHECK TORQUE TO 150 FT-LBS (DRY) AS REQUIRED
ROTATION GEAR BOX			X			CHECK TORQUE TO 85 FT-LBS (DRY) AS REQUIRED
ROTATION GEAR BOX				X		EP GEAR LUBE SAE 140
HOIST GEARBOX				X		EP GEAR-EP GEAR LUBE SAE 80-90, SPUR GEAR SAE 30 OIL
HYDRAULIC FLUID					X	DRAIN, FLUSH, AND REFILL WITH SUN2105 HYD. OIL, SAE 5W-20
BOOM SLIDE PADS	PADS GREASED WHEN REPLACED					

## **LUBRICATION & MAINTENANCE SCHEDULE**

### **6006EH CRANE**

SERVICE PERFORMED	DAY	WEEKLY	3 MOS	6 MOS	YEAR	NOTES
FOR ADDITIONAL INFORMATION SEE:	1) OWNER'S MANUAL 2) OSHA SECTION 1910.180 3) ANSI B30.5-1989					

**CAUTION: Routine maintenance insures trouble-free operation and protects your investment. All warranties are void if maintenance is neglected.**

#### **NOTES:**

1. Use only authorized parts. Any damage or malfunction caused by the use of unauthorized parts is not covered by Warranty or Product Liability.
2. Once a bolt has been torqued to its rated capacity and then removed; the bolt should be replaced with a new one.
3. Auto Crane Company recommends that this crane be serviced per "Crane Inspection Log" P/N 999978. These logs should be filled in at the intervals noted and kept as a permanent record. Additional copies are available from your local distributor.

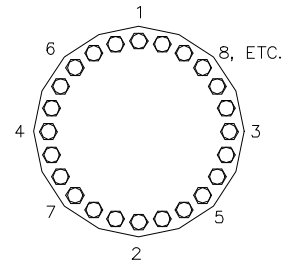
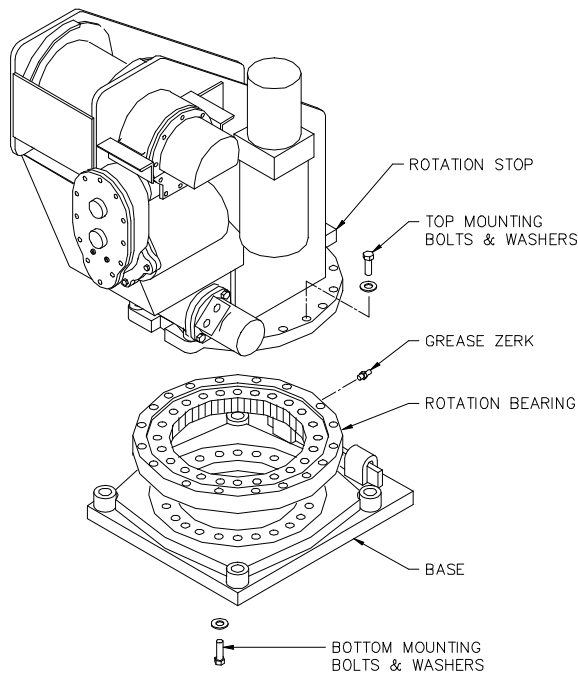

TORQUE SEQUENCE ILLUSTRATION

LUBRICATION OF ROTATION BEARING

RACE

1. LUBRICATE BEARING RACE AT THE GREASE ZERK LOCATED ON THE OUTSIDE OF THE ROTATION BEARING DIRECTLY UNDER THE ROTATION STOP OF THE PEDESTAL.
2. LISTED IN THE CHART BELOW ARE SEVERAL LUBRICANTS WHICH ARE ACCEPTABLE FOR BOTH RUST INHIBITING AND EXTREME PRESSURE CHARACTERISTICS.
  - A. LUBRICATE THE BEARING DAILY IF THE CRANE IS USED ON A DAILY BASIS.
  - B. LUBRICATE THE BEARING EVERY 30 DAYS IF THE CRANE IS USED INTERMITTENTLY.
  - C. ROTATE THE BEARING THROUGH TWO OR MORE ROTATIONS DURING LUBRICATION PROCESS.

GEAR

1. THE CHART BELOW LISTS SEVERAL LUBRICANTS FOR THE GEAR. IT IS RECOMMENDED THAT THE TEETH BE LUBRICATED WITH A SMALL AMOUNT OF GREASE EVERY 8 HOURS IF THE CRANE IS USED DAILY. THE GREASE IS PURGED FROM THE TEETH BY THE VERY NATURE OF BEING EXPOSED TO THE ELEMENTS. THEREFORE CLOSE ATTENTION TO THE GEAR LUBRICANT WILL PROVIDE A LONGER TOOTH LIFE. GREASE THE GEAR TEETH AT THE PINION LOCATION.

INSTALLATION OF ROTATION BEARING

1. MAKE SURE MOUNTING SURFACES ARE FLAT AND CLEAR OF DEBRIS.
2. INSTALL BEARING SUCH THAT THE GREASE ZERK ON THE BEARING IS LOCATED DIRECTLY UNDER THE ROTATION STOP OF THE PEDESTAL.
3. INSTALL TOP AND BOTTOM BOLTS AND FLAT WASHERS. ALL BOLTS MUST BE GRADE 8 AND USED WITH HARDENED FLAT WASHERS. REFER TO PEDESTAL ASSEMBLY FOR PART NUMBERS.
4. SNUG ALL BOLTS , THEN TIGHTEN ACCORDING TO THE TORQUE SEQUENCE ILLUSTRATION UNTIL ALL BOLTS ARE TORQUED TO 150 FT.-LBS (NON-PLATED) OR 110 FT.-LBS (PLATED).

NOTE: BOLTS SHOULD BE CHECKED PERIODICALLY AND RETIGHTENED TO PROPER TORQUE.

5. GREASE THE ROTATION BEARING ACCORDING TO LUBRICATION INSTRUCTIONS AT LEFT.
6. SET BACKLASH OF THE ROTATION ACTUATOR AND THE ROTATION BEARING AT THE HIGH POINT OF THE ROTATION BEARING GEAR TEETH. IDENTIFIED BY A YELLOW PAINT MARK ON THE TEETH.

	MOBIL	TEXACO	SUNOCO	PURE	SOHIO
RACE	MOBILPLEX EP #2	MARFAC MP #2	PRESTIGE 742EP	POCO HT EP #2	SOHITRAN EP #1
GEAR	MOBILCOTE-S	CRATER COMPOUND	407 COMPOUND B	POCO GEARSHIELD	SOHITAC #1

AW-346  
ROTATION BEARING MAINTENANCE

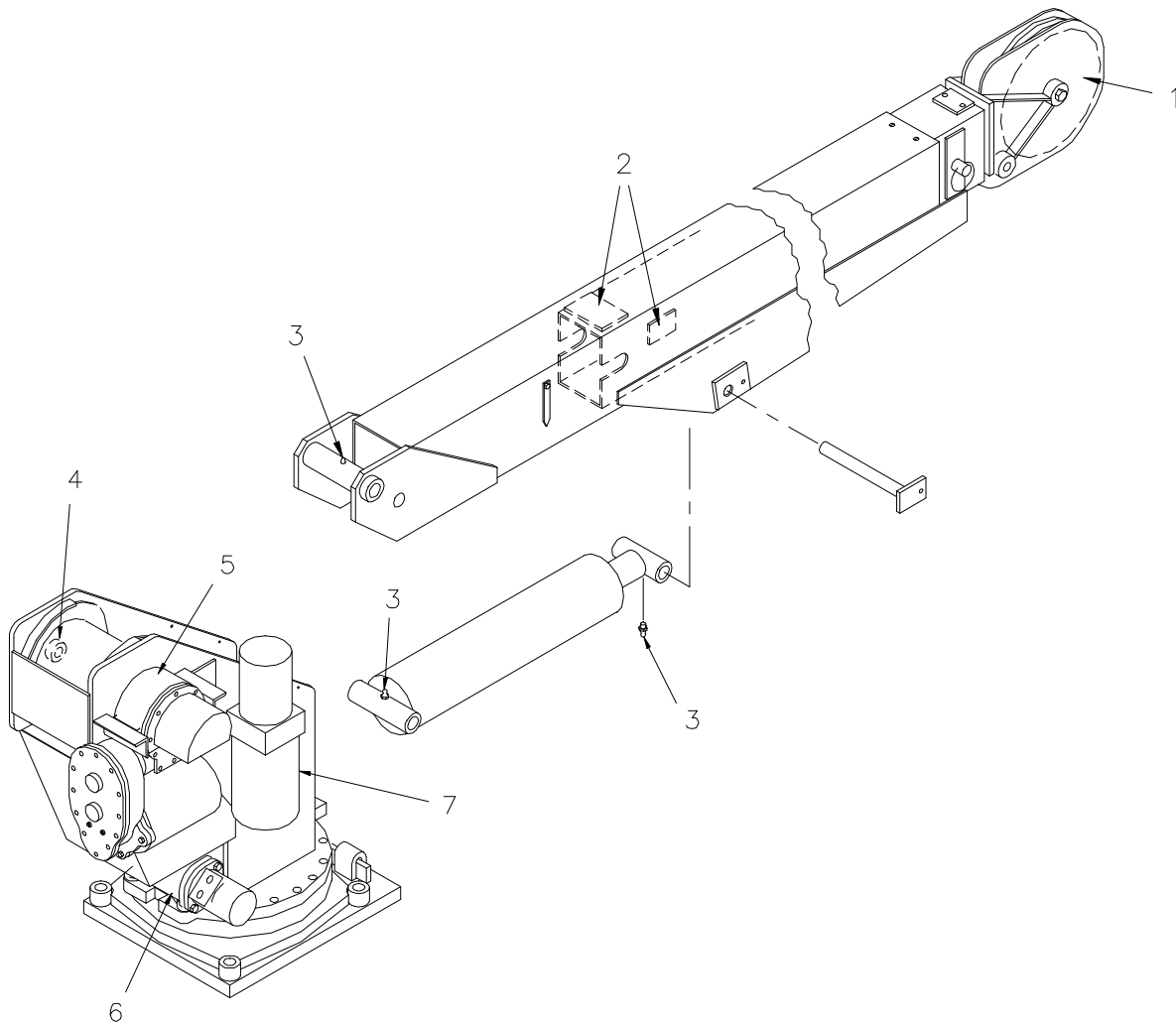

- |   |  |
|---|--|
| <p>1. SHEAVE ROLLER BEARINGS:<br/>SEALED TYPE, NO LUBE REQUIRED.</p> <p>2. BOOM PADS:<br/>IF REPLACED, GREASE UPON INSTALLATION WITH CHASSIS LUBRICANT.</p> <p>3. PIVOT POINT GREASE ZERKS:<br/>LUBE ONCE A WEEK WITH MOBILPLEX EP-2 OR EQUIVALENT.</p> <p>4. HOIST ROLLER BEARINGS:<br/>SEALED TYPE, NO LUBE REQUIRED.</p> | <p>5. HOIST ACTUATOR:<br/>MAINTAIN GEAR BOX LUBRICANT AT FILL PLUG. USE ONE PINT OF EP GEAR LUBE SAE 80-90. REPLACE EVERY SIX MONTHS.</p> <p>6. ROTATION ACTUATOR:<br/>MAINTAIN OIL LEVEL OF 1 1/2 PINTS OF EP GEAR LUBE, SAE 140. REPLACE EVERY SIX MONTHS.</p> <p>7. HYDRAULIC FLUID:<br/>USE DTE-13 OR EQUIVALENT. RESERVOIR SHOULD BE FLUSHED AND NEW FLUID ADDED ONCE A YEAR, OR IF A HYDRAULIC FAILURE OCCURS.</p> |
|---|--|

AW-391  
LUBRICATION MAINTENANCE

# MAINTENANCE OF BATTERIES

Maintenance of Auto Crane unit batteries differs very little from the generally prescribed maintenance of any lead acid battery. All batteries must be kept *properly charged, properly filled with water, and relatively clean.*

## Keep Properly Charged

Many things affect the proper charge to a battery, such as:

- 1 Regulator settings
- 2 Proper tightness of belts on the alternator or generator
- 3 Good, clean connections of all cables and wires at the following places:
  - A. Battery
  - B. Regulator
  - C. Starting motor
  - D. Alternator or generator
  - E. Ground connections (most important)

It is of extreme importance to keep the battery as fully charged as possible without overcharging, especially when vehicles are left outside for extended periods in extremely cold climates. A battery *can* freeze. Freezing points for various specific gravities of acid are as follows:

Specific Gravity (Corrected to 80°F)	Freezing Temp. Degrees F.
1.280	-90°F
1.250	-62°F
1.200	-16°F
1.150	5°F
1.100	19°F

As shown, a half-charged battery (about 1.200 specific gravity) cannot stand for any length of time at 20°F or it will freeze.

The *main reason* for keeping the battery as fully charged as possible without over-charging is to ensure that power is available even though the vehicle has been standing for some time.

## Keep Properly Filled with Water

The battery should *always* be properly filled with water. If the electrolyte level is allowed to fall below the top of the plates, the results become threefold:

- 1 The exposed portion of the plate will become sulfated.
- 2 The portion of the plate exposed is not usable.
- 3 That portion of the acid remaining becomes more concentrated and may cause more rapid deterioration of the remaining parts of the battery.

## Keep A Relatively Clean Battery

The battery should be kept clean. Batteries filled with acid and which are not in use self-discharge to a limited degree because of the nature of the materials within the battery. If dirt is allowed to collect on the top of the battery (and this dirt absorbs moisture) and electrical path can be set up between the various terminals of the battery and the ground. Once such a path has been established, the self-discharge of the battery is accelerated. This also accelerates corrosion of the battery cables at the terminals.

## Periodic Maintenance is Needed

A definite program of periodic maintenance of all batteries should be conducted on a regular basis. Periodic maintenance includes:

- 1 Checking belts for tightness on the charging equipment
- 2 Checking battery electrolyte levels
- 3 Checking cables for good connections
- 4 Cleaning where corrosion is apparent

When corrosion is cleaned off, the cable terminals and battery terminals should be coated with a light coating of petroleum jelly before they are replaced. When terminals are cleaned, the top of the battery should be cleaned with a mild solution of soda water.

# ***MAINTENANCE OF BATTERIES***

## **Low Maintenance Batteries (Maintenance Free)**

**Low maintenance batteries should not be used on Auto Cranes or trucks equipped with Auto Cranes. The batteries are not designed for "deep" discharge.**

## **Testing Your Battery**

If the condition of the battery is in question, it should be removed from the vehicle, taken to the shop, and allowed to reach room temperature. It should then be recharged until specific gravity readings taken at one-half hour intervals. If the specific gravity readings are fairly uniform, the battery should be checked with a high rate tester. Use the tester in accordance with the manufacturer's instructions. The high rate tester is the best method to test a questionable battery.

If, after charging, it is noted that the specific gravity reading of one cell is 30 points less than any of the other cells, it may be assumed that the cell is bad and that the battery should be replaced. If all cells are uniform but not up to full charge, a low rate of charge

should be attempted for an extended time. This usually will recover a badly sulfated battery.

## **Replacing a Battery**

If it is necessary to replace a battery, and a dry charge battery is used, the following procedure applies:

- 1 Fill the battery with electrolyte of the proper specific gravity.
- 2 Place the battery on charge according to the manufacturer's instructions.

It is essential that the second step above be followed to ensure that the battery going on the vehicle is fully charged.

It is also very important that the battery hold-downs be checked periodically to ensure that the batteries are properly positioned to avoid vibration problems, breakage of cables or terminals. Care must be taken to avoid cracking or breaking containers or covers by tightening hold-down fixtures excessively. They also must not be so loose that breakage results from a hold-down that is too loose.

# **OVERLOAD SYSTEM / ANTI-2-BLOCK**

## **TROUBLE SHOOTING GUIDE**

**IF THE THREE FUNCTIONS, BOOM DOWN, HOIST UP AND EXTEND OUT, QUIT WORKING**, the problem probably lies in either the Overload System or the Anti-2-block system or both. If these three functions are NOT WORKING and most other functions are, an investigation should be made as follows: (reference: Figure 1)

### **1 ANTI-2-BLOCK**

- A. Unplug the anti-2-block system from the overload system and connect A and B to bypass the anti-2-block system.
- 1. If the three functions work, check continuity of anti-2-block system using continuity tester at disconnected. Weather pack connectors, and investigate switch at end of boom, cable and cable reel.**
  - 2. If the three functions do not work, continue on with section #2.**

### **2 LOAD SENSOR (Pressure Switch)**

- A. With crane unloaded, unplug weather pack connector on load sensor wire.
- 1. If the three functions work, recheck the Pressure Switch by taking a ohm reading on the two wires coming from the Switch. The switch has normally open contacts, so the reading should be the maximum. If less than maximum ohm reading is indicated (usually a dead short), replace the Switch.**
  - 2. If the three functions do not work, continue with section #3.**

### **3 RELAY BOX**

- A. Inside this box are two 320355 relays. Since these are inexpensive relays, the easiest way to trouble shoot this device is to replace both relays.
- 1. The two relays are identical but serve different functions. RELAY A is the one with the most wires going to its connector. RELAY A breaks the circuit between the ground side of the solenoid valves on boom down, extend out, and hoist up functions. This happens whenever the overload switch on the lift cylinder senses more than normal pressure indicating an overload condition. When overload happens then 12 volts is passed through the overload switch to pull in RELAY A which then interrupts the ground circuit of the valves controlling those**

**functions which could cause additional overload. In addition to this, when there is also a signal from the boom down solenoid to RELAY B at the same time, RELAY B latches RELAY A so that even if the overload signal from the pressure switch to RELAY A is removed, RELAY A will continue to be on and interrupt the ground circuit until the signal from the boom down solenoid and pressure switch are removed.**

- 2. The purpose of RELAY A is to interrupt the ground circuit and stop hoist up, boom down, and extend out functions from operating. The purpose of RELAY B is to stop boom bounce caused by the overload system cycling on and off.**

### **4 OPERATIONAL TEST AND TROUBLE SHOOTING OF RELAY BOX**

- A. After the anti-2-block test and the load sensor tests have been performed and the overload system still does not operate, check the relay box.
- 1. Disconnect the weatherpak connector in the load sensor pressure switch wires going from the pressure switch to the relay box. Disconnect the weatherpak connector between the cord reel and the relay box.**
  - 2. Check for 12 volts at pin B of load sensor connector on relay box side of harness. Short from pin A to pin B of weatherpak. When pins A & B are shorted there should NOT be continuity from the cord reel weatherpak on the relay box side of the connection to ground. When A & B are not shorted there should be continuity to ground. Replace relay A if these conditions are not met.**
  - 3. If the boom tends to bounce when booming down due to intermittent cycling of the overload system, then RELAY B should be replaced after verifying that the sense wire from the relay box to the boom down solenoid valve control terminal is connected.**



# OVERLOAD SYSTEM / ANTI-2-BLOCK

## TROUBLE SHOOTING GUIDE

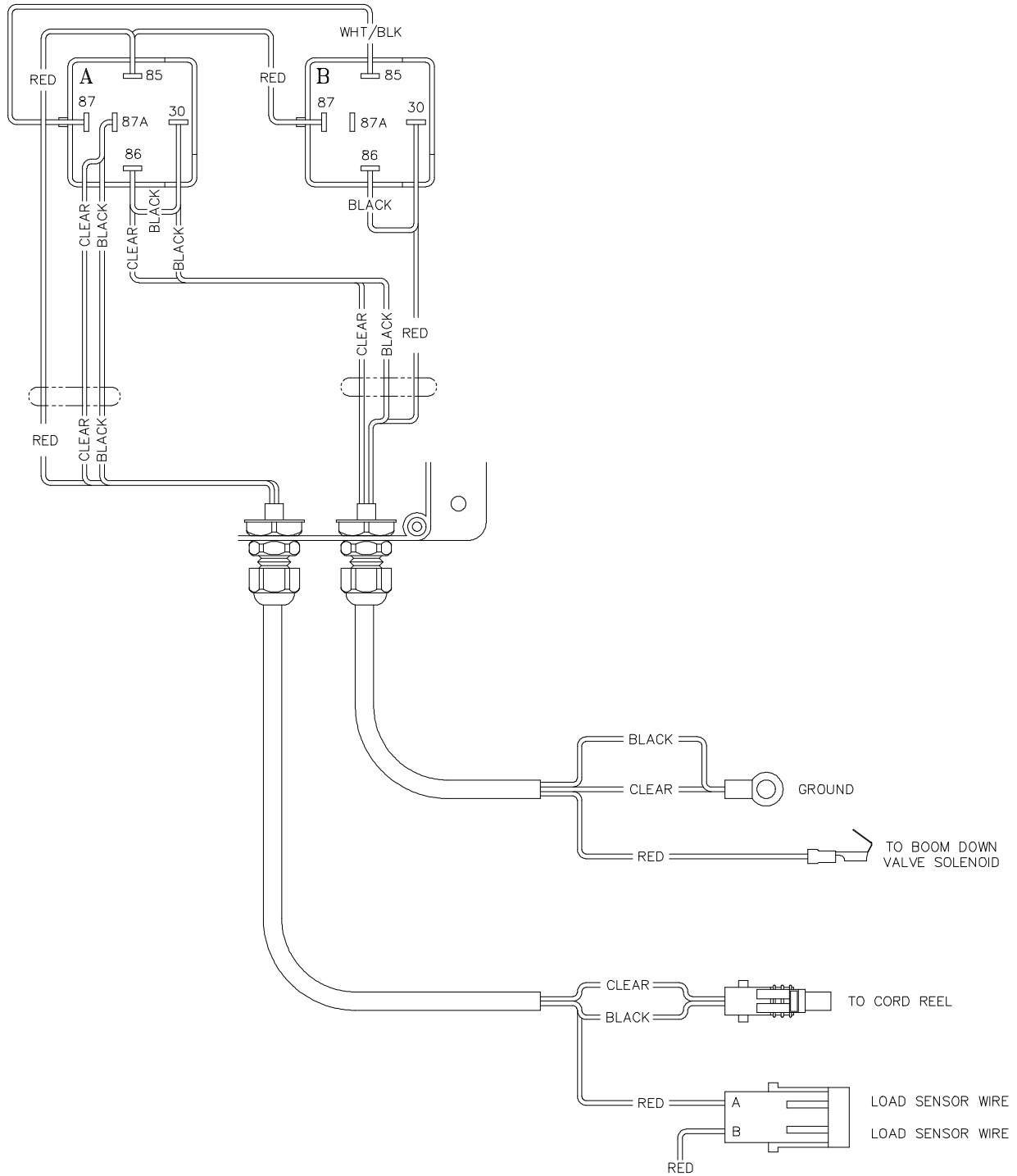

# HYDRAULICS

## 6006EH

### Counterbalance Valve Adjustment

- { With PTO disengaged and boom properly supported, remove O-ring plug (item 17) shown on AW-573 marked "X" port (see CB valve diagram). Install a pressure gauge (0-2500 PSI) into the port.
- { Engage PTO and insure pump flow is 10

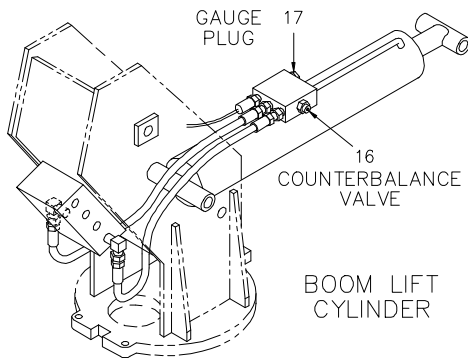

AW-573

GPM and main relief is set to 2500 PSI. With no load on boom, boom up to an angle of 70 degrees. Boom down and note pressure. If pressure reading is not approximately 1050 PSI, the counterbalance valve requires adjustment.

- v To increase the CB valve setting, loosen nut and turn Allen head screw counter clockwise. (Reference item 16, located on the side of the CB valve block towards the right side of the boom.)
- v To reduce the CB valve setting, loosen nut and turn Allen head screw clockwise.

- { Tighten nut on adjustment screw and repeat procedure if needed to obtain the proper pressure setting.
- { Disengage PTO, remove the pressure gauge and install -6 plug. Crane is now ready for operation.

### *Notice:*

- { In an EMERGENCY situation when it becomes necessary to lower the boom without flow present, the CB valve adjustment can be turned in until the boom begins to descend. Make sure the boom will lower onto a proper support. Loosen the lock nut and carefully turn adjustment screw clockwise! Count the number of turns. *Turn slowly until the boom just begins to lower, and remove hand/arm/fingers from cranes while boom is lowering.*
- { Turning adjustment screw too far will cause valve to come apart on the inside. This condition is not repairable
- { After boom is lowered, turn adjustment screw counter clockwise the approximate number of turns made during lowering procedure. After the problem is corrected, readjust the counterbalance valve using the procedure in this manual.

**WARNING:**  
**DO NOT TRY TO ADJUST VALVES WHILE BOOM IS MOVING. Failure to heed warning may result in personal injury!**

# PEDESTAL ASSEMBLY

## MODEL 6006EH

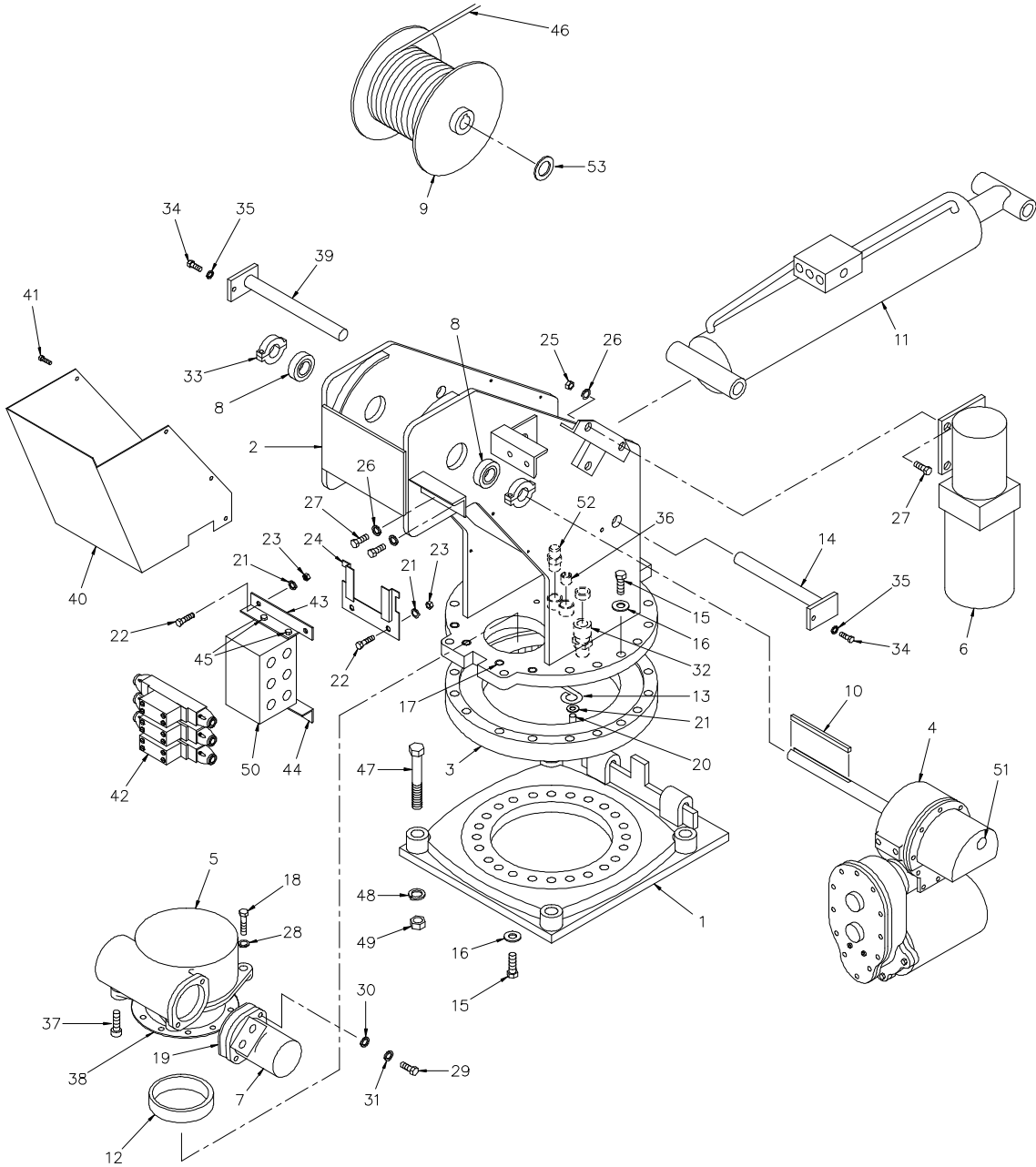

# ***PEDESTAL ASSEMBLY***

## ***MODEL 6006EH***

<b><u>ITEM</u></b>	<b><u>QTY</u></b>	<b><u>P/N</u></b>	<b><u>DESCRIPTION</u></b>
1	1	360536	BASE PLATE ASSEMBLY
2	1	366810	PEDESTAL WELDMENT
3	1	480023-002	ROTATION BEARING
4	1	360807	24V WINCH
5	1	480028	ROTATION GEAR BOX
6	1	360798	HYD PUMP & RESERVOIR POWER UNIT
7	1	480027	HYD ROTATION MOTOR
8	2	400500	BEARING
9	1	366802	HOIST DRUM
10	1	360557	5/16 KEY
11	1	366805	BOOM UP CYLINDER
12	1	360162	ECCENTRIC RING
13	1	360207	ECCENTRIC RING RETAINER
14	1	366191	PEDESTAL / CYLINDER PIN
15	38	012198	SCREW HX HD 5/8 NC x 1 3/4 G8
16	38	023902	WASHER FLAT 5/8 HARDENED
17	4	006205	SCREW HX HD 5/8 NC x 1 1/4 G8
18	2	011608	SCREW HX HD 1/2 NC x 2 G8
19	1	480019	MOTOR GASKET
20	1	007402	SCREW HX HD 5/16 NC x 5/8 G5
21	7	020600	WASHER SP LK 5/16
22	6	007811	SCREW HX HD 5/16 NC x 1
23	6	016500	NUT HX 5/16 NC
24	1	366987	RELAY BOX RETAINER
25	3	017100	NUT HX 3/8 NC
26	7	021100	WASHER SP LK 3/8
27	7	008601	SCREW HX HD 3/8 NC x 7/8 G5
28	2	021500	WASHER SP LK 1/2
29	2	012197	SCREW SOC HD 1/2 NC x 1 1/2 G5
30	2	021502	WASHER SP LK 1/2 (HI-COLLAR)
31	2	021601	WASHER FLAT 1/2 SAE (SPECIAL)
32	1	370433	CABLE CONNECTOR
33	2	330468	SPLIT-LOCK COLLAR
34	2	005500	WASHER HX HD 1/4 NC x 3/4
35	2	020200	WASHER SP LK 1/4
36	1	750477	PIPE PLUG 1/2
37	2	009118	SCREW SOC HD 1/2 NC x 2 G5
38	1	480011	ROTATION BOX SEAL

# ***PEDESTAL ASSEMBLY***

## ***MODEL 6006EH***

<b><u>ITEM</u></b>	<b><u>QTY</u></b>	<b><u>P/N</u></b>	<b><u>DESCRIPTION</u></b>
39	1	366192	LOWER BOOM PIVOT PIN
40	1	360867	COVER
41	6	002608	SCREW HX HD 1/4 NC x 3/4 ST
42	3	300204	DIRECTIONAL VALVE ASSEMBLY
43	1	320392	TOP MANIFOLD BRACKET
44	1	320393	BOTTOM MANIFOLD BRACKET
45	4	002614	SCREW HX HD 5/16 NC x 5/8 ST
46	1	480031	WIRE ROPE ASSEMBLY 3/8 x 95 FT
47	4	015104	SCREW HX HD 7/8 NF x 5 G8
48	4	022200	LOCKWASHER 7/8
49	4	018900	NUT HX 7/8 NF
50	1	202710	MANIFOLD
51	1	360848	1"Ø PLASTIC PLUG
52	1	642908	CORD CONNECTOR
53	2	480073	WINCH SHAFT SPACER

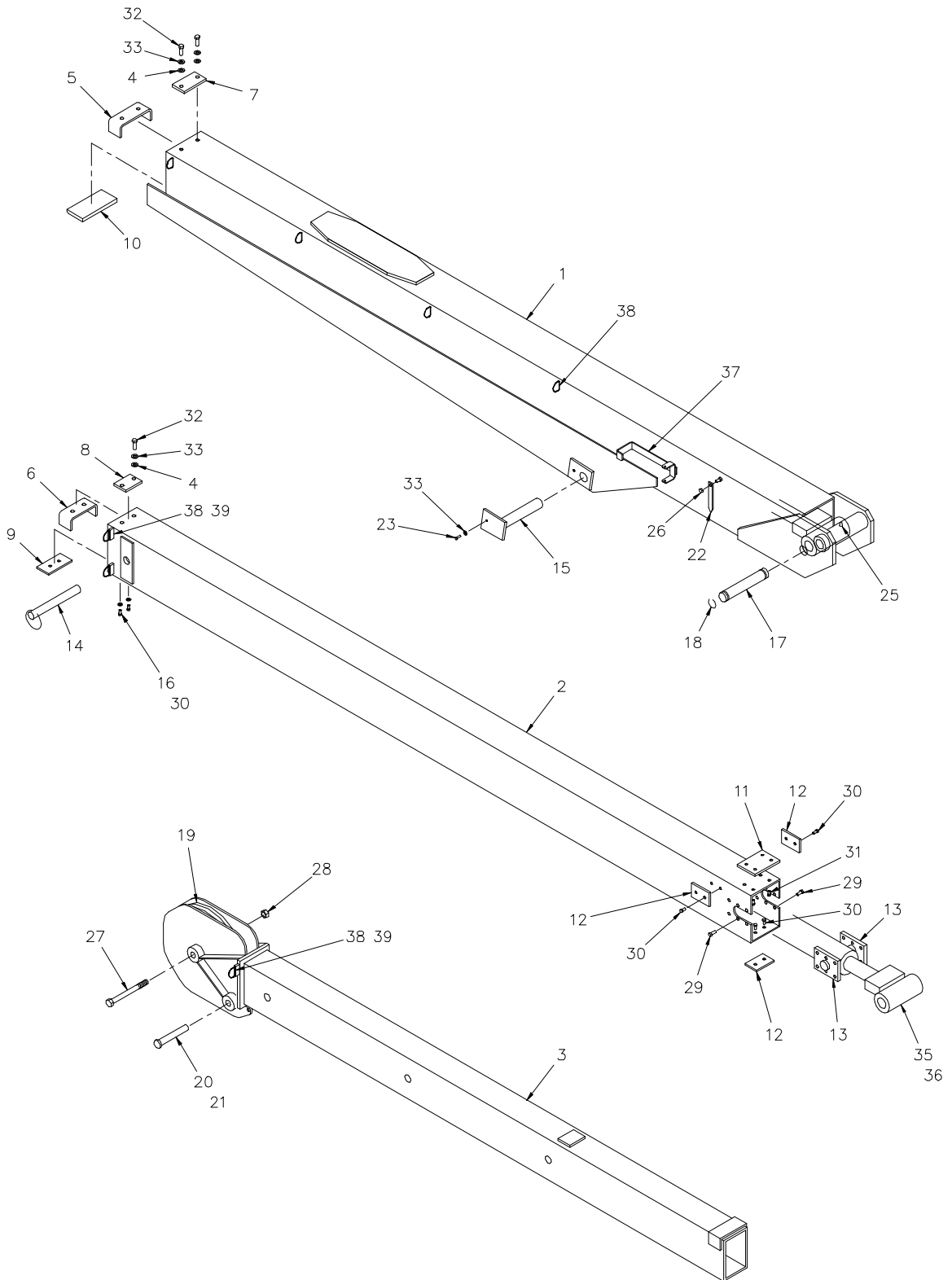

AW-392  
6006EH 10-16-20 BOOM ASSEMBLY

AW-392  
6006EH 10-16-20 BOOM ASSEMBLY

ITEM	QTY.	PART NO.	DESCRIPTION
1	1	480581	BOOM, LOWER (SEE NOTE 1)
2	1	366080	BOOM, CENTER
3	1	366110	BOOM, MANUAL
4	6	021200	WASHER, FLAT 3/8
5	1	366183	STOP, CENTER
6	1	366112	STOP, UPPER BOOM
7	1	366201	PAD, BOOM TOP
8	1	366202	PAD, BOOM TOP
9	1	366199	PAD, BOOM
10	1	366187	PAD, RETAINER LOWER
11	1	366185	PAD, BOOM (CENTER BOOM)
12	3	366186	PAD, BOOM (CENTER BOOM)
13	2	366184	RETAINER, EXTENSION CYLINDER
14	1	366190	PIN, ASSEMBLY w/ LANYARD
15	1	366189	PIN, BOOM CYLINDER
16	2	020600	WASHER, SP. LK. 5/16
17	1	366193	PIN, EXTENSION CYLINDER
18	2	480029	RING, RETAINING
19	1	366198	SHEAVE ASSEMBLY 3/8 (BEARING ONLY - 366197)
20	1	360125	PIN, BLOCK
21	1	360124	PIN, HITCH
22	2	360038	ANGLE INDICATOR
23	1	366158	SCREW, HEX HD. 3/8-16NC x 3/4 LG. GR.8
24	.	.	.
25	1	239000	GREASE ZERK
26	2	016300	NUT, HEX LOCK 1/4-20NC
27	1	014304	SCREW, HEX HD. 3/4-16NF x 6" LG. GR.5
28	1	018600	NUT, HEX LOCK 3/4-16NF
29	12	008400	SCREW, HEX HD. 3/8-16NC x 3/4 LG.
30	8	007808	SCREW, HEX HD. 5/16-24NF x 1/2 LG.
31	4	005406	SCREW, HEX HD. 1/4-28NF x 1/2 LG.
32	4	008800	SCREW, HEX HD. 3/8-24NF x 1" LG.
33	6	021100	WASHER, SP. LK. 3/8
34	.	.	.
35	1	366162	CYLINDER, EXTENSION (COMPLETE)
	-	366162-001	CASE ASSEMBLY
	-	366162-002	SHAFT ASSEMBLY
	-	366162-003	HEAD GLAND
	-	366162-004	PISTON
36	1	366166	SEAL KIT
37	1	REF.	CORD REEL BRACKET (320551)
38	7	REF.	D-RING (366108)
39	3	REF.	SPACER (800246-025)
 <u>NOTES:</u>			
1.) BOOM 366070 HAS HOOKS FOR PENDANT CABLE. BOOM 480581 IS EXACTLY THE SAME LESS THE HOOKS AND IS USED FOR PROPORTIONAL UNITS.			

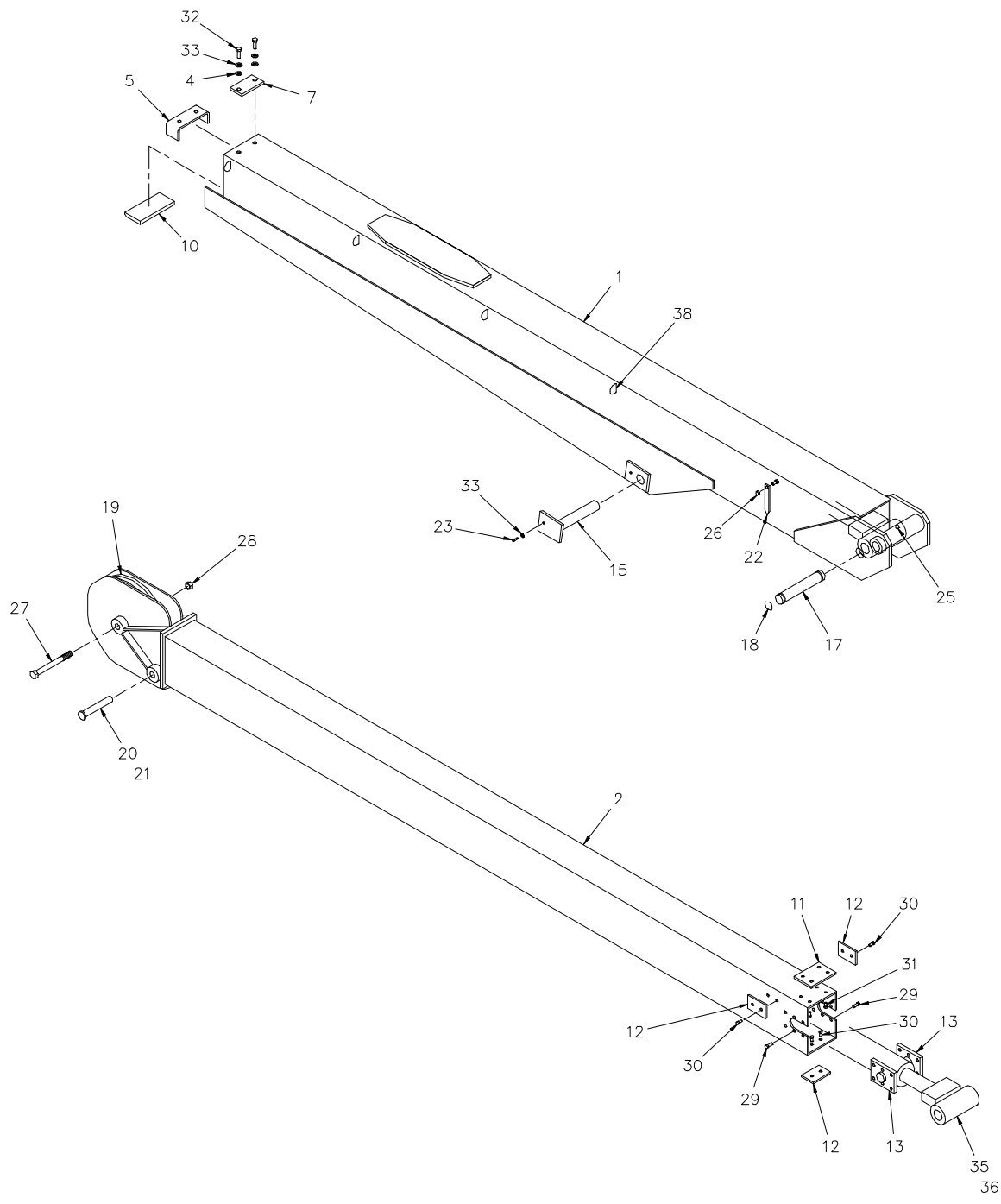

AW-396  
6006EH 10-16 BOOM ASSEMBLY



AW-396  
6006EH BOOM ASSEMBLY

ITEM	QTY.	PART NO.	DESCRIPTION
1	1	480581	BOOM, LOWER (SEE NOTE 1)
2	1	366817	BOOM, CENTER
3	.	.	.
4	4	021200	WASHER, FLAT 3/8
5	1	366183	STOP, CENTER
6	.	.	.
7	1	366201	PAD, BOOM TOP
8	.	.	.
9	.	.	.
10	1	366187	PAD, RETAINER LOWER
11	1	366185	PAD, BOOM (CENTER BOOM)
12	3	366186	PAD, BOOM (CENTER BOOM)
13	2	366184	RETAINER, EXTENSION CYLINDER
14	.	.	.
15	1	366189	PIN, BOOM CYLINDER
16	2	020600	WASHER, SP. LK. 5/16
17	1	366193	PIN, EXTENSION CYLINDER
18	2	480029	RING, RETAINING
19	1	366198	SHEAVE ASSEMBLY 3/8 (BEARING ONLY - 366197)
20	1	360125	PIN, BLOCK
21	1	360124	PIN, HITCH
22	2	360038	ANGLE INDICATOR
23	1	366158	SCREW, HEX HD. 3/8-16NC x 3/4 LG. GR.8
24	.	.	.
25	1	239000	GREASE ZERK
26	2	016300	NUT, HEX LOCK 1/4-20NC
27	1	014304	SCREW, HEX HD. 3/4-16NF x 6" LG. GR.5
28	1	018600	NUT, HEX LOCK 3/4-16NF
29	12	008400	SCREW, HEX HD. 3/8-16NC x 3/4 LG.
30	6	007808	SCREW, HEX HD. 5/16-24NF x 1/2 LG.
31	4	005406	SCREW, HEX HD. 1/4-28NF x 1/2 LG.
32	2	008800	SCREW, HEX HD. 3/8-24NF x 1" LG.
33	4	021100	WASHER, SP. LK. 3/8
34	.	.	.
35	1	366162	CYLINDER, EXTENSION (COMPLETE)
	-	366162-001	CASE ASSEMBLY
	-	366162-002	SHAFT ASSEMBLY
	-	366162-003	HEAD GLAND
	-	366162-004	PISTON
36	1	366166	SEAL KIT

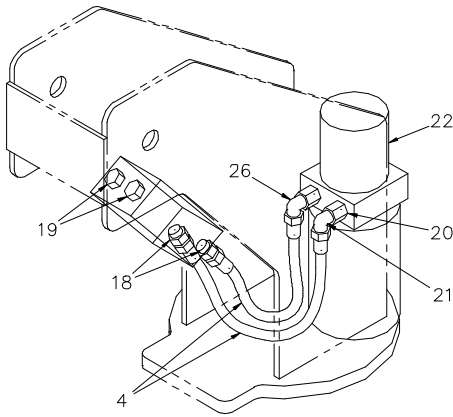

POWER UNIT

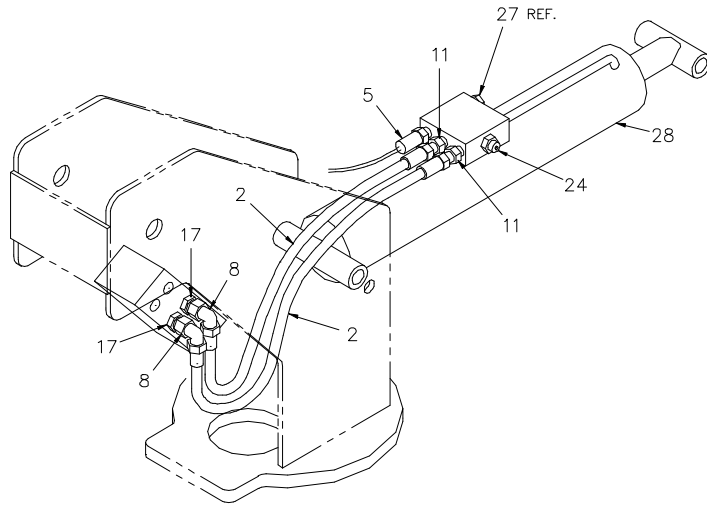

BOOM UP  
(MIDDLE SPOOL)

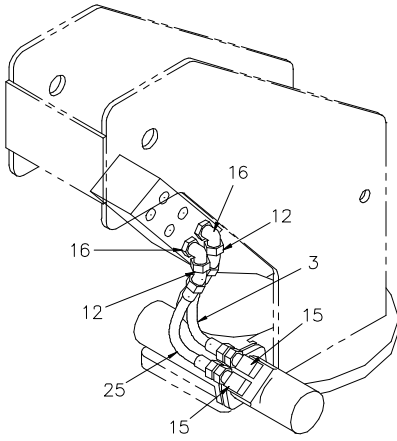

ROTATION  
(BOTTOM SPOOL)

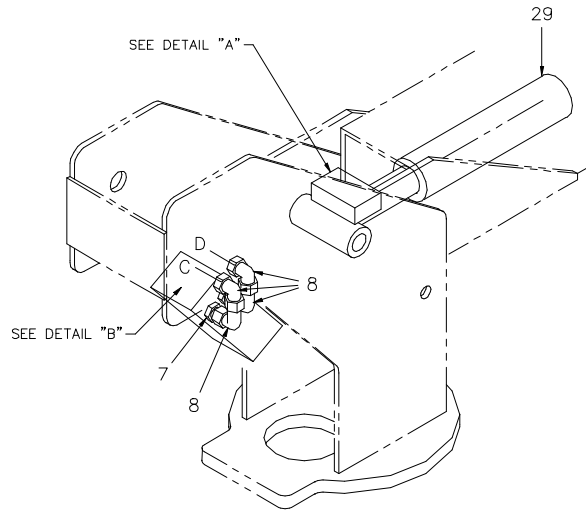

EXTENSION  
(TOP SPOOL)

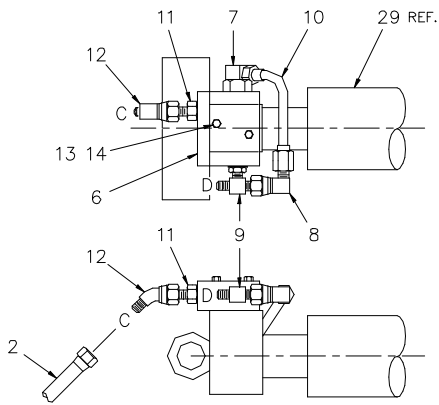

DETAIL "A"

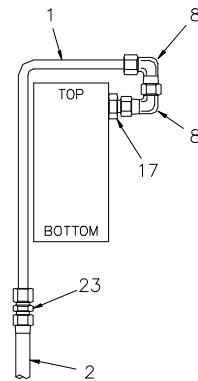

DETAIL "B"

AW-380  
6006EH HYDRAULIC ASSEMBLY  
10-16-20 BOOM

AW-380, 6006EH HYDRAULIC ASSEMBLY (10-16-20)

ITEM	QTY.	PART NO.	DESCRIPTION
1	2	320489	TUBE ASSEMBLY
2	4	480208	HOSE ASSEMBLY
3	1	812203-013	HOSE ASSEMBLY
4	2	360573	HOSE ASSEMBLY
5	1	320543	LOAD SENSOR
6	1	330412	VALVE, COUNTERBALANCE
7	1	200892	ELL, 90° -6 NPT/-6 JIC
8	7	480194	ELL, 90° -6 JIC SWIVEL/-6 JIC
9	1	241168	TEE, -6 ORB/-6 JIC RUN
10	1	480212	TUBE ASSEMBLY
11	3	200876	ADAPTER, -6 ORB/-6 JIC
12	3	330647	ELL, 45° -6 JIC SWIVEL
13	2	005810	SCREW, HX HD 1/4NC X 1 3/4 LG.
14	2	020200	WASHER, SP LK 1/4
15	2	202759	ELL, 90° -8 NPT/-6 JIC
16	2	330272	ELL, 90° -8 ORB/-6 JIC
17	4	202756	ADAPTER, -8 ORB/-6 JIC
18	2	202755	ADAPTER, -10 ORB/-6 JIC
19	2	330072	PLUG, HX HD -10 ORB
20	1	320336-002	RETURN PORT PLUG
21	1	241175	ELL, 90° -6 ORB/-6 JIC
22	1	360808	POWER UNIT
23	2	241170	UNION, -6 JIC
24	1	480188	COUNTERBALANCE VALVE CARTRIDGE
25	1	812203-014	HOSE ASSEMBLY
26	1	330645	ELL, 90° -6 ORB/-6 JIC EXTRA LONG
27	1	REF.	PLUG, -6 ORB
28	1	366805	CYLINDER, BOOM UP
29	1	366162	CYLINDER, EXTENSION

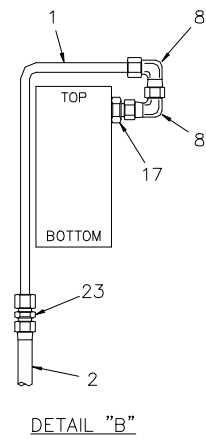
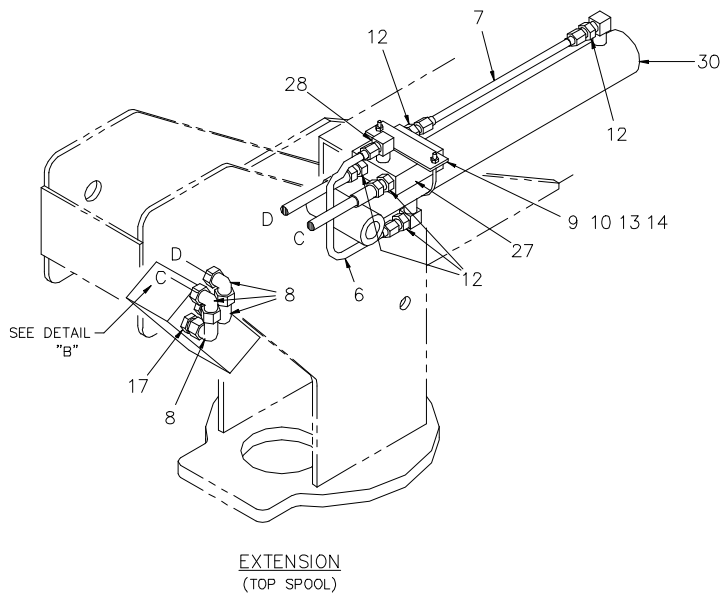
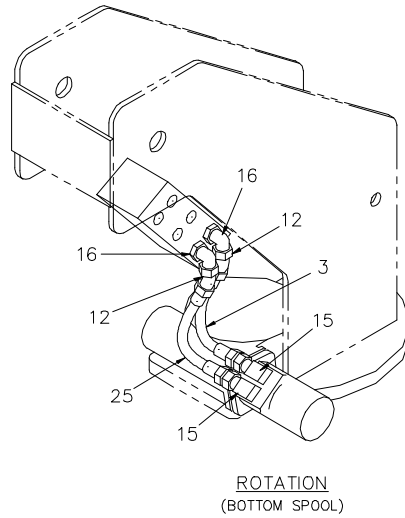
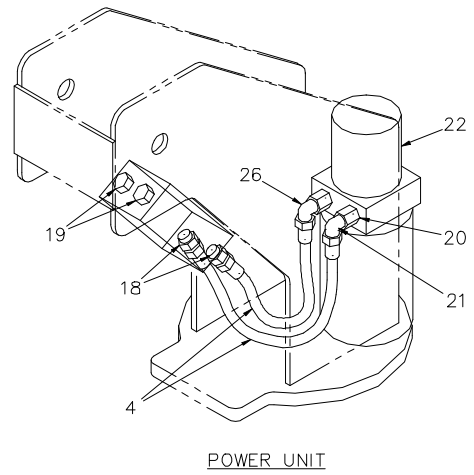
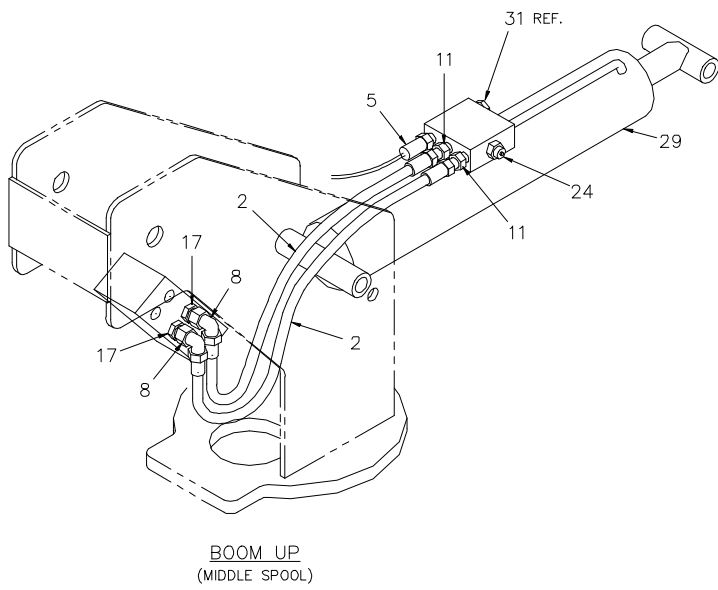

AW-393  
6006EH HYDRAULIC ASSEMBLY  
10-16 BOOM

AW-393, 6006EH HYDRAULIC ASSEMBLY (10-16)

ITEM	QTY.	PART NO.	DESCRIPTION
1	2	320489	TUBE ASSEMBLY
2	4	480208	HOSE ASSEMBLY
3	1	812203-013	HOSE ASSEMBLY
4	2	360573	HOSE ASSEMBLY
5	1	320543	LOAD SENSOR
6	1	360069	TUBE ASSEMBLY
7	1	360070	TUBE ASSEMBLY
8	6	480194	ELL, 90° -6 JIC SWIVEL/-6 JIC
9	1	360091	U-BOLT
10	1	360092	CLAMP
11	2	200876	ADAPTER, -6 ORB/-6 JIC
12	5	360042	ADAPTER, -6 NPT/-6 JIC
13	2	015900	NUT, HEX HD 1/4-NC
14	2	020200	WASHER, SP LK 1/4
15	2	202759	ELL, 90° -8 NPT/-6 JIC
16	2	330272	ELL, 90° -8 ORB/-6 JIC
17	4	202756	ADAPTER, -8 ORB/-6 JIC
18	2	202755	ADAPTER, -10 ORB/-6 JIC
19	2	330072	PLUG, HX HD -10 ORB
20	1	320336-002	RETURN PORT PLUG
21	1	241175	ELL, 90° -6 ORB/-6 JIC
22	1	360808	POWER UNIT
23	2	241170	UNION, -6 JIC
24	1	480188	COUNTERBALANCE VALVE CARTRIDGE
25	1	812203-014	HOSE ASSEMBLY
26	1	330645	ELL, 90° -6 ORB/-6 JIC EXTRA LONG
27	1	360153	VALVE, COUNTERBALANCE
28	1	200892	ELL, 90° -6 NPT/-6 JIC
29	1	366805	CYLINDER, BOOM UP
30	1	360152	CYLINDER, EXTENSION
31	1	REF.	PLUG, -6 ORB

# HYDRAULIC PUMP & RESERVOIR

P/N 360798

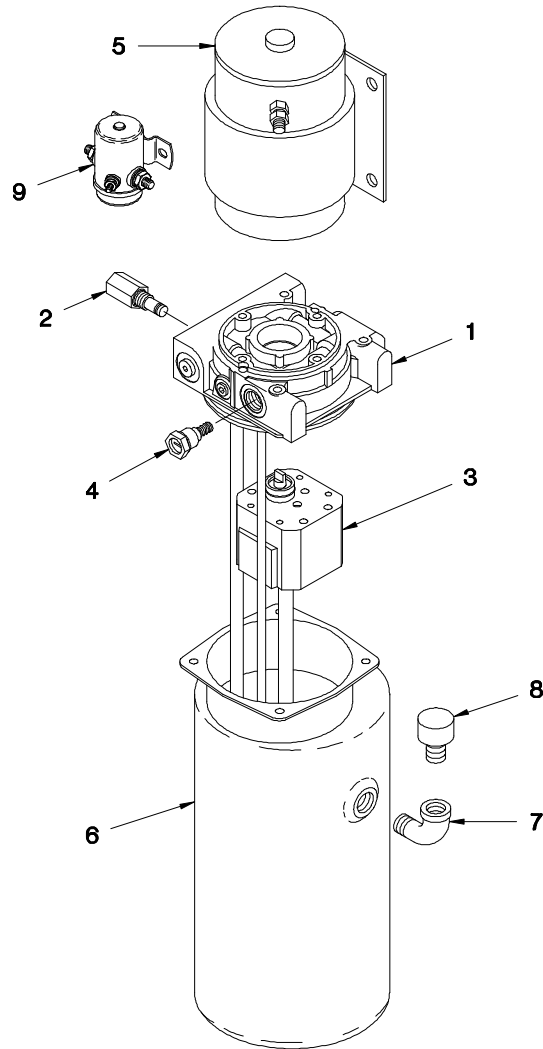

<u>ITEM</u>	<u>QTY</u>	<u>P/N</u>	<u>DESCRIPTION</u>
1	1	360808-003	ADAPTER KIT
2	1	320336-002	RETURN PORT PLUG KIT
3	1	360808-001	PUMP KIT
4	1	320336-003	RELIEF VALVE KIT
5	1	360808-002	MOTOR
6	1	360799	RESERVOIR KIT
7	1	320335-008	ELBOW FITTING
8	1	200545	BREATHER CAP
9	1	330630	SOLENOID

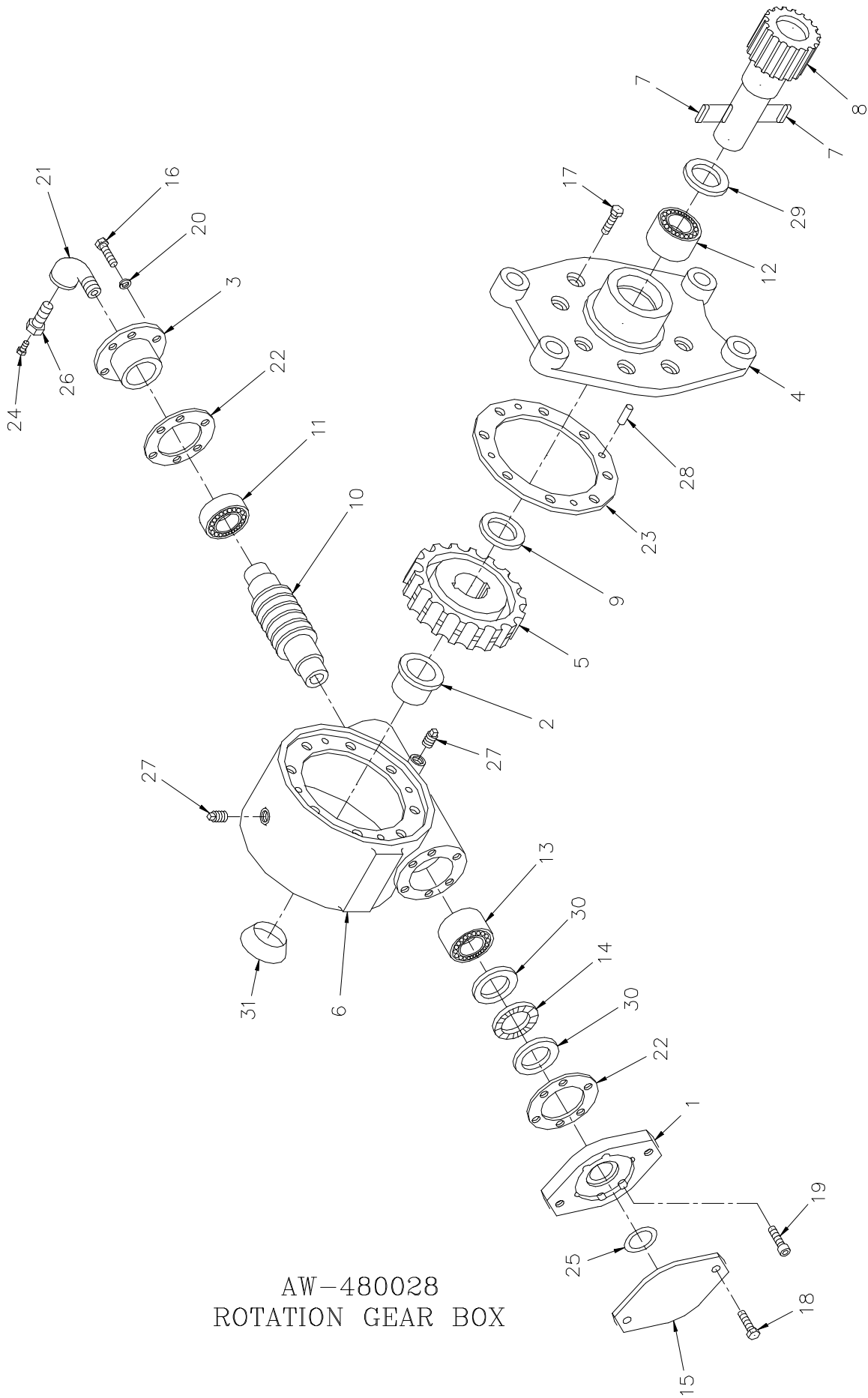

AW-480028  
 ROTATION GEAR BOX

AW-480028  
 ROTATION GEAR BOX

AW-480028  
ROTATION GEAR BOX

ITEM	QTY.	PART NO.	DESCRIPTION
1	1	480240	ADAPTER
2	1	480241	BUSHING
3	1	480242	CAP, BEARING
4	1	480243	COVER
5	1	480244	GEAR, R.H.
6	1	480237	HOUSING, GEAR
7	2	480246	KEY
8	1	480247	SHAFT, OUTPUT
9	1	480248	WASHER, THRUST
10	1	480249	WORM, R.H.
11	1	480251	BEARING, BALL
12	1	480252	BEARING, NEEDLE
13	1	480253	BEARING, NEEDLE
14	1	480254	BEARING, THRUST
15	1	480255	COVER
16	6	007400	CAPSCREW, 5/16-18NC X 1" LG. HX. HD.
17	8	480238	CAPSCREW, 5/16-18NC X 1 1/4 LG. HX. NYLOC HVY PATCH
18	2	011508	CAPSCREW, 1/2-13NC X 3/4 LG. HX. HD.
19	6	480256	CAPSCREW, 5/16-18NC X 1" LG. SOC. HD. LOC.-WEL
20	6	480258	LOCKWASHER, 5/16 MED. SECT. C.P.
21	1	480259	ELBOW, 90°
22	2	480260	GASKET
23	1	480250	GASKET
24	1	480262	FITTING, RELIEF
25	1	480239	O-RING
26	1	480263	REDUCER
27	2	480264	PLUG, PIPE
28	4	480265	PIN, DOWEL
29	1	480266	SEAL, OIL
30	2	480268	WASHER, THRUST
31	1	480269	PLUG, EXPANSION



(BB) NEXT PAGE

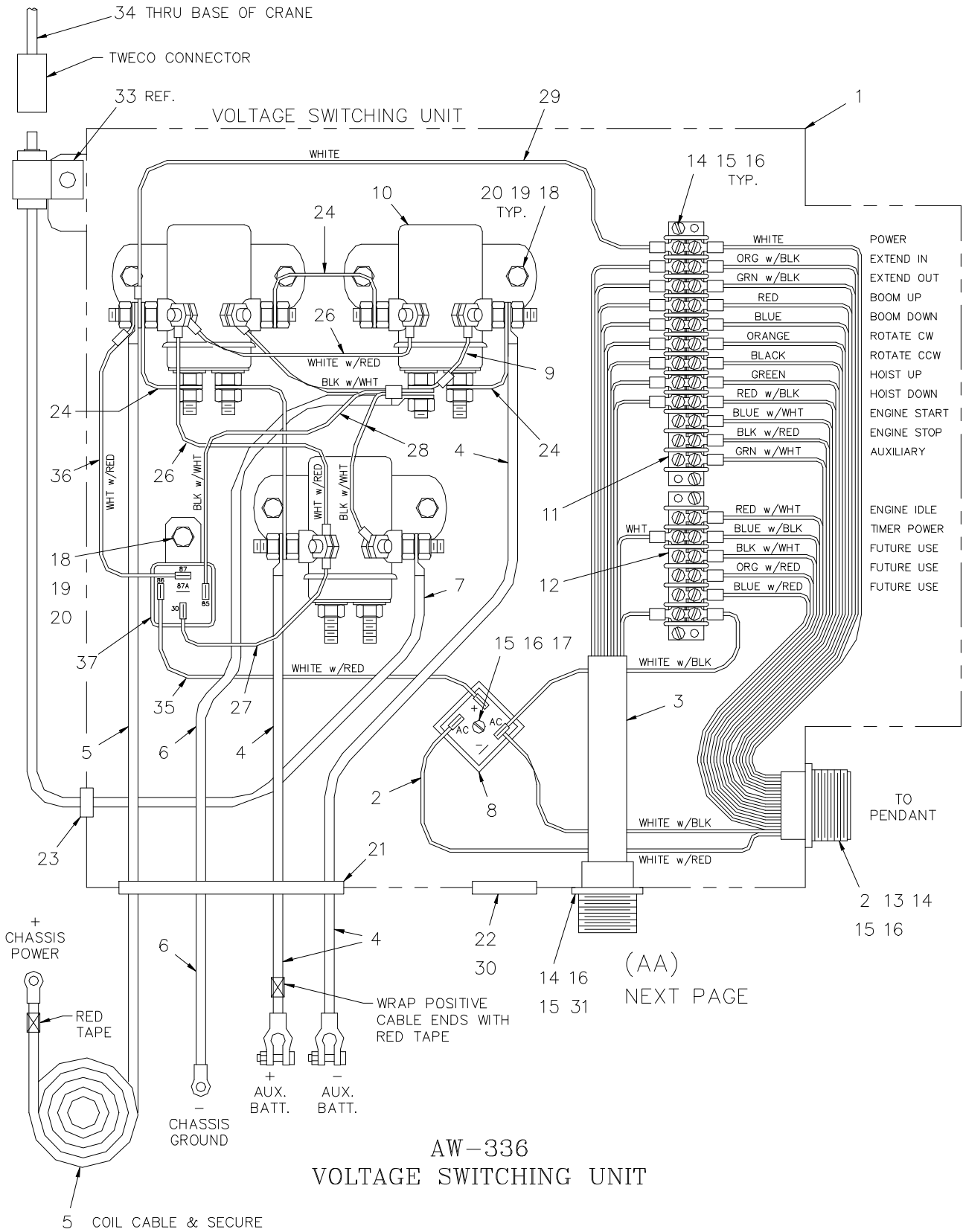

AW-336  
VOLTAGE SWITCHING UNIT

(AA)  
NEXT PAGE

AW-336, VOLTAGE SWITCHING UNIT

ITEM	QTY.	PART NO.	DESCRIPTION
1	1	360832	ENCLOSURE ASSEMBLY
2	1	680081	RECEPTACLE ASSEMBLY
3	1	360834	POWER CABLE, RECEPTACLE ASSY
4	2	360853	BATTERY CABLE
5	1	360858	CONDUCTOR ASSEMBLY (25'-9")
6	1	360859	CONDUCTOR ASSEMBLY (6'-9")
7	1	360844-002	CONDUCTOR ASSEMBLY (w/ MALE TWECO)
8	1	751138	RECTIFIER, BRIDGE 25 AMP
9	1	360845	CONDUCTOR ASSEMBLY
10	3	200182	RELAY
11	1	635200	TERMINAL BLOCK, 12 STATION
12	1	635203	TERMINAL BLOCK, 6 STATION
13	1	480547	CAP, RECEPTACLE
14	8	000404	SCREW, #6-32NC x 5/8 LG.
15	9	015400	NUT, HEX #6-32NC
16	9	019600	WASHER, SP LK #6
17	1	000602	SCREW, #6-32NC x 1 LG.
18	6	005901	SCREW, HEX HD 1/4-20NC x 1/2 LG.
19	6	015900	NUT, HEX 1/4-20NC
20	6	020200	WASHER, SP LK 1/4
21	1	750282	GROMMET
22	1	371024	GROMMET
23	1	750169	GROMMET
24	4	658300	CONDUCTOR ASSEMBLY (COPPER STRIP)
25	2	360872	CONDUCTOR ASSEMBLY
26	2	360873	CONDUCTOR ASSEMBLY
27	1	360841	CONDUCTOR ASSEMBLY
28	1	360876	CONDUCTOR ASSEMBLY
29	1	360877	CONDUCTOR ASSEMBLY
30	1	360878	CAP PLUG, TAPERED
31	1	360879	CAP PLUG (10 PIN RECEPTACLE)
32	1	360837	DECAL, V.S.U. WIRING DIAGRAM
33	1	480024	MOUNT, CABLE RETAINER
34	1	360844-001	CONDUCTOR ASSEMBLY (w/ FEMALE TWECO)
35	1	360868	CONDUCTOR ASSEMBLY
36	1	360871	CONDUCTOR ASSEMBLY
37	1	320355	RELAY, DROP OUT

# ELECTRICAL SCHEMATIC

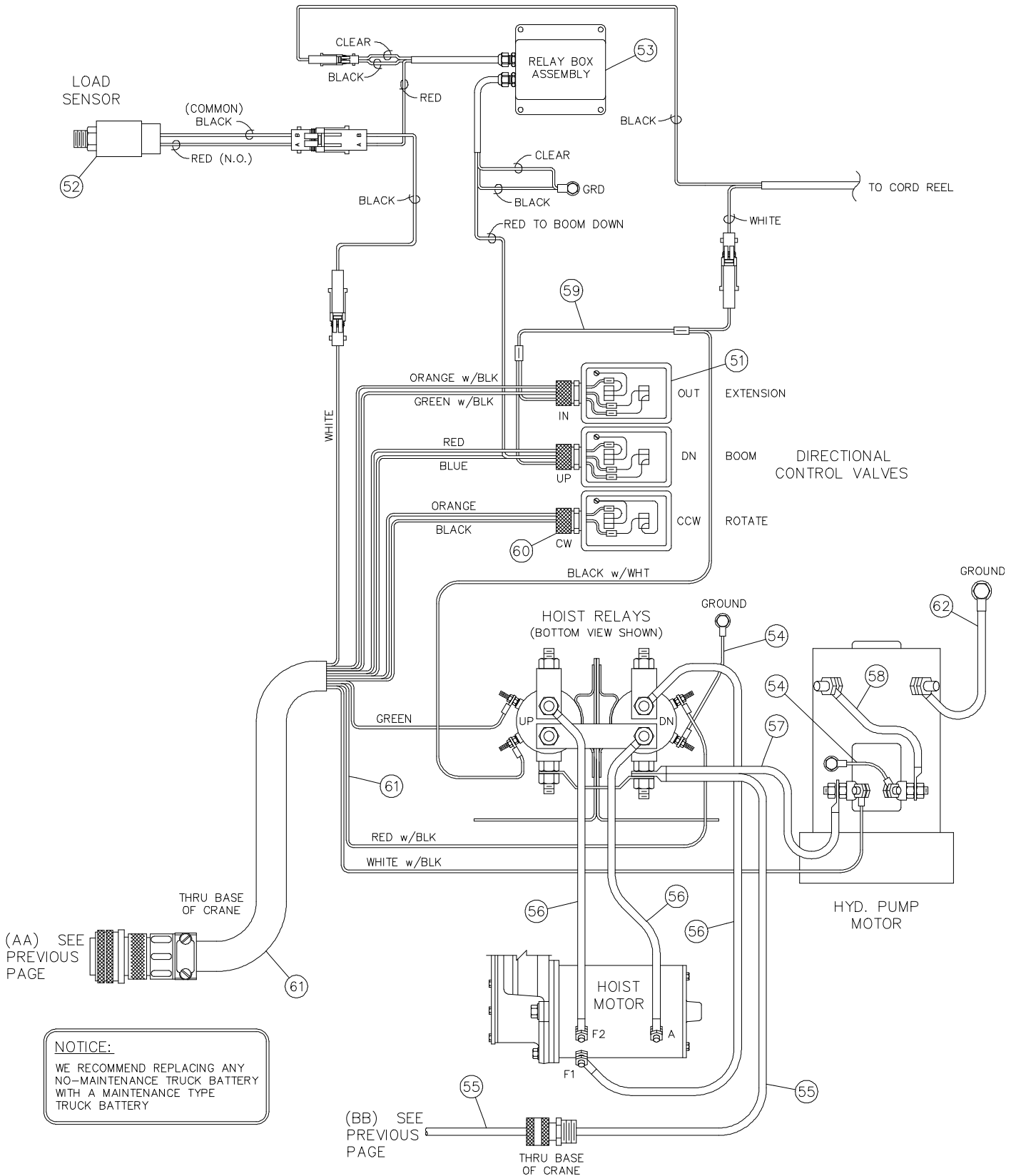

# ***ELECTRICAL SCHEMATIC***

<u>ITEM</u>	<u>QTY</u>	<u>P/N</u>	<u>DESCRIPTION</u>
50	1	REFERENCE	VOLTAGE SWITCHING UNIT (360802-001)
51	3	300204	DIRECTIONAL CONTROL VALVE
52	1	320543	LOAD SENSOR ASSEMBLY
53	1	366999	RELAY BOX ASSEMBLY
54	2	360872	CONDUCTOR ASSEMBLY
55	1	360844-001	CONDUCTOR ASSEMBLY (WITH FEMALE TWECO)
56	3		CONDUCTOR ASSEMBLY (SUPPLIED WITH HOIST)
57	1	360011	CONDUCTOR ASSEMBLY
58	1		CONDUCTOR ASSEMBLY (SUPPLIED WITH POWER UNIT)
59	1	360846	CONDUCTOR ASSEMBLY
60	3	642908	CONDUCTOR CORD
61	1	360857	POWER CABLE PLUG ASSEMBLY
62	1	360843	CONDUCTOR ASSEMBLY
63	6 FT	750736	CONVOLUTED LOOM
64	1	360844-002	CONDUCTOR ASSEMBLY (WITH MALE TWECO)

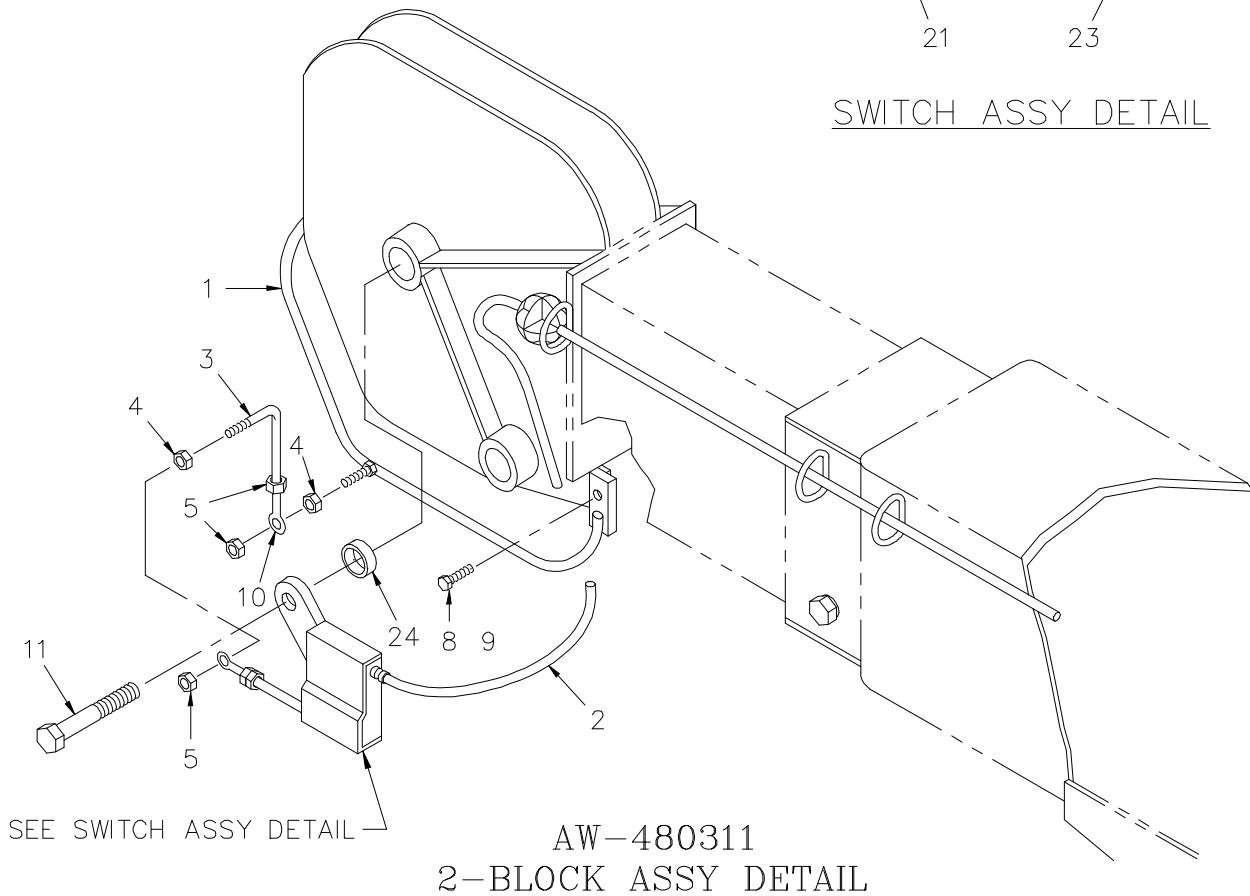
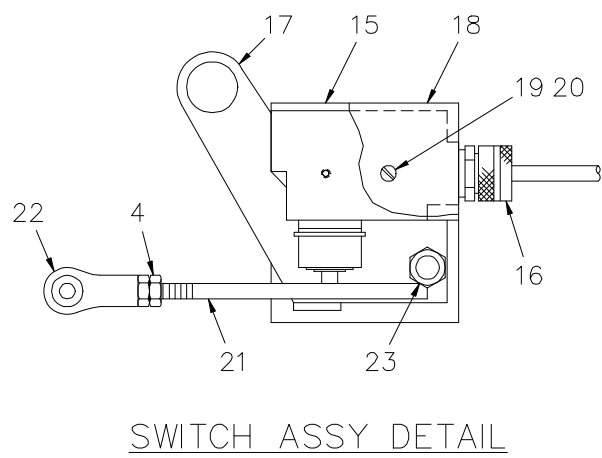
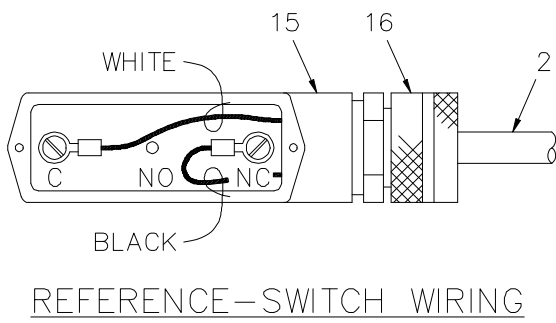
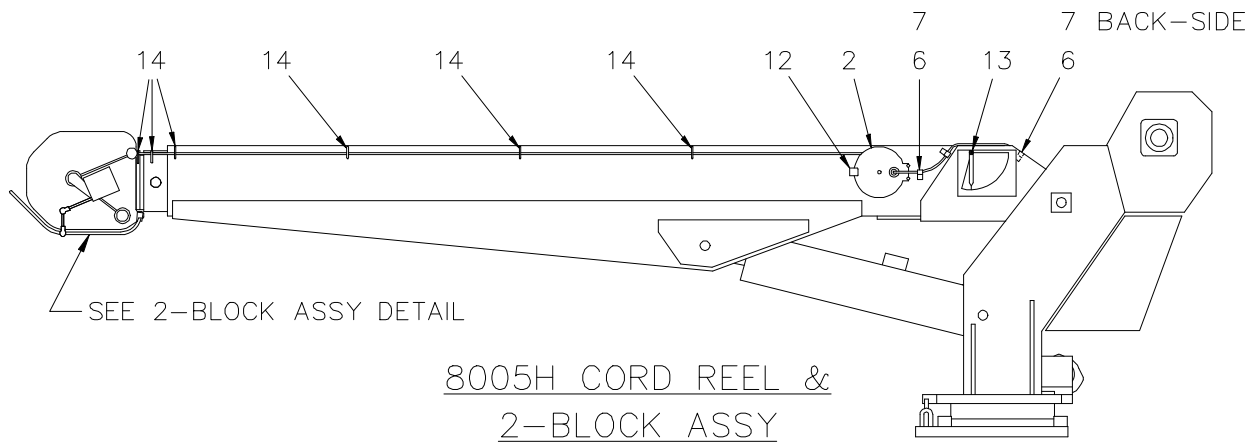

2-BLOCK ASSEMBLY AW-480311

ITEM	QTY.	PART NO.	DESCRIPTION
1	1	366116-001	BAIL, 2-BLOCK CROWN BRACKET
2	1	366973-001	CORD REEL ASSY
3	1	366196	2-BLOCK ARM
4	4	016100	NUT, HEX HD. 1/4-28 NF
5	3	016200	NUT, HEX LOCK 1/4-28 NF
6	3	002608	SCREW, HEX HD. SELF TAPPING 1/4-20 NC x 3/4 LG.
7	3	000115	CLIP, #15
8	1	007803	SCREW, HEX HD. 5/16-18 NC x 3 1/2 LG.
9	1	016801	NUT, HEX LOCK 5/16-18 NC
10	1	363006	BEARING, ROD END
11	1	REF.	SCREW, HEX HD. 3/4-16 NF x 6" LG.
12	1	320551	BRACKET, REEL MOUNT
13	2	005901	SCREW, 1/4-20 NC x 1/2 LG.
14	6	366108	D-RING
15	1	646900	SWITCH
16	1	642908	CORD CONNECTOR
17	1	363013-001	MOUNTING PLATE ASSY
18	1	363004	COVER, SWITCH
19	2	002602	SCREW, RD. HD. #6-32 NC x 1 1/4 LG.
20	2	019600	WASHER, SP. LK. #6
21	1	363005	LINKAGE, WELDMENT ROD
22	1	363006	BEARING, ROD END
23	1	017301	NUT, HEX LOCK 3/8-16 NC
24	1	480009	SPACER 1 1/8 X .120W X 3/8 LG.

# RELAY BOX ASSEMBLY

P/N 366999

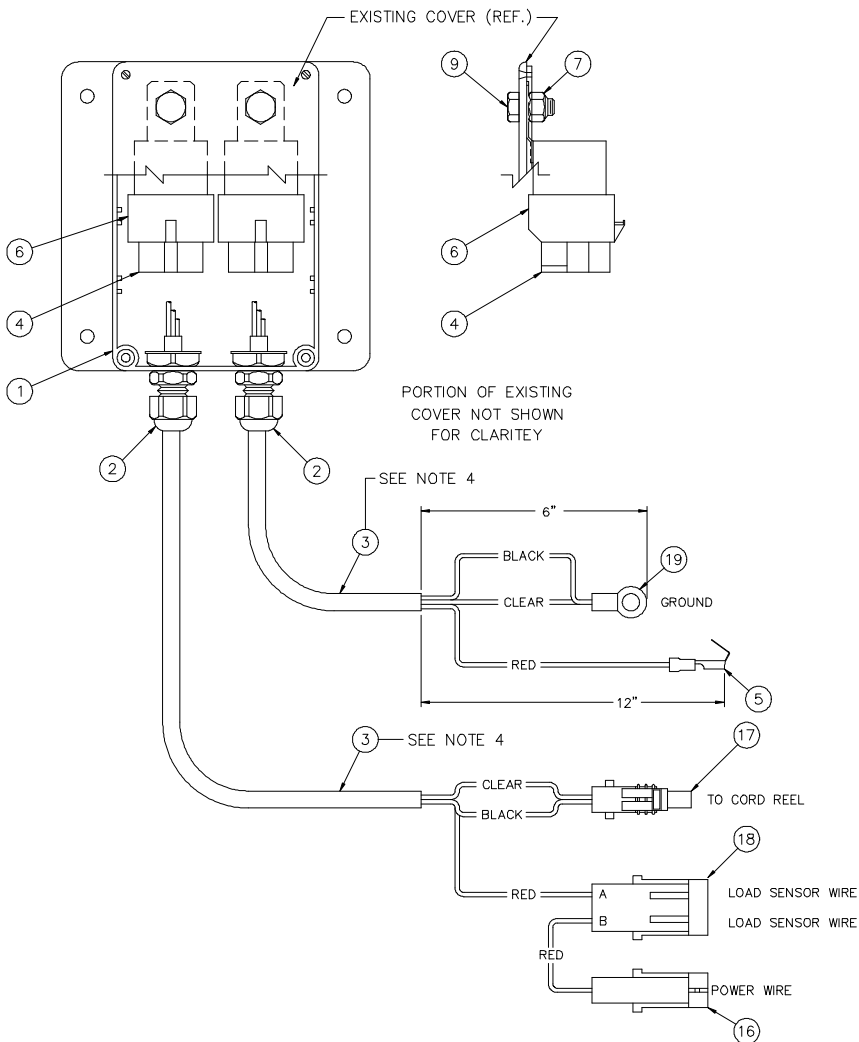
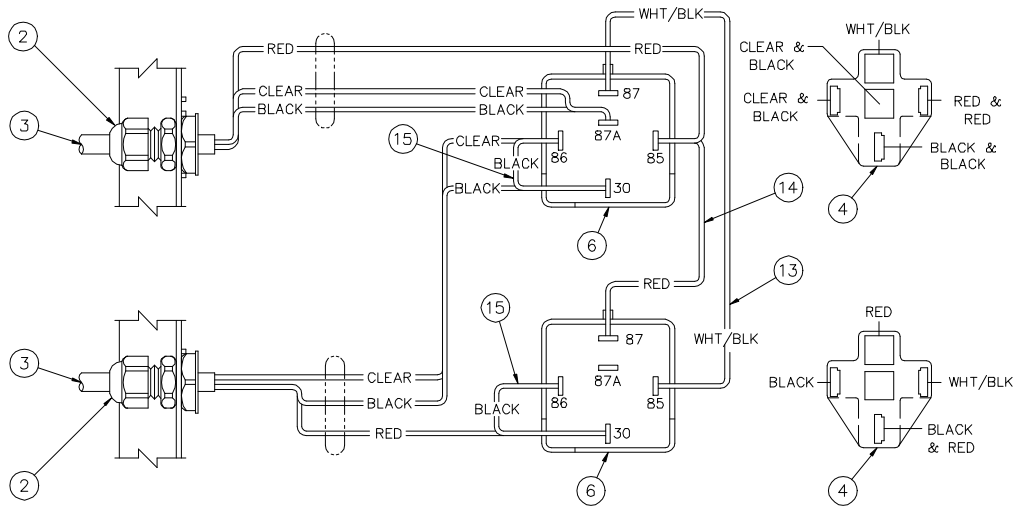

# ***RELAY BOX ASSEMBLY***

***P/N 366999***

<b><u>ITEM</u></b>	<b><u>QTY</u></b>	<b><u>P/N</u></b>	<b><u>DESCRIPTION</u></b>
1	1	366990	PLASTIC ENCLOSURE W/ 6 DRILL HOLES
2	2	366968	CORD CONNECTOR
3	2	366967	SHIELDED CABLE 3-CONDUCTOR 18-20
4	2	320363	TERMINAL CONNECTOR PLUG
5	1	366980	PIGGY BACK TERMINAL INSULATED 18-20
6	2	320355	BOSCH DROP OUT RELAY
7	2	005901	HEX HD SCREW 1/4-20 NC x 1/2 LG
8	-	-	-
9	2	016300	LOCK NUT 1/4-20 NC
10	-	-	-
11	-	-	-
12	11	320357	NON-INSULATED TERMINAL W/ LOCK DEVICE
13	1	341566	WHT/BLK ELECTRICAL WIRE 18 AWG 600V
14	1	341564	RED ELECTRICAL WIRE 18 AWG 600V
15	2	341565	BLACK ELECTRICAL WIRE 18 AWG 600V
16	1	366248	WEATHER PACK 1-WAY MALE 18-20
17	1	366249	WEATHER PACK 1-WAY FEMALE 18-20
18	1	366250	WEATHER PACK 2-WAY MALE 18-20
19	1	000601	RING TERMINAL 10-3/8
20	3	750737	CABLE TIE



# PENDANT

## P/N 680050

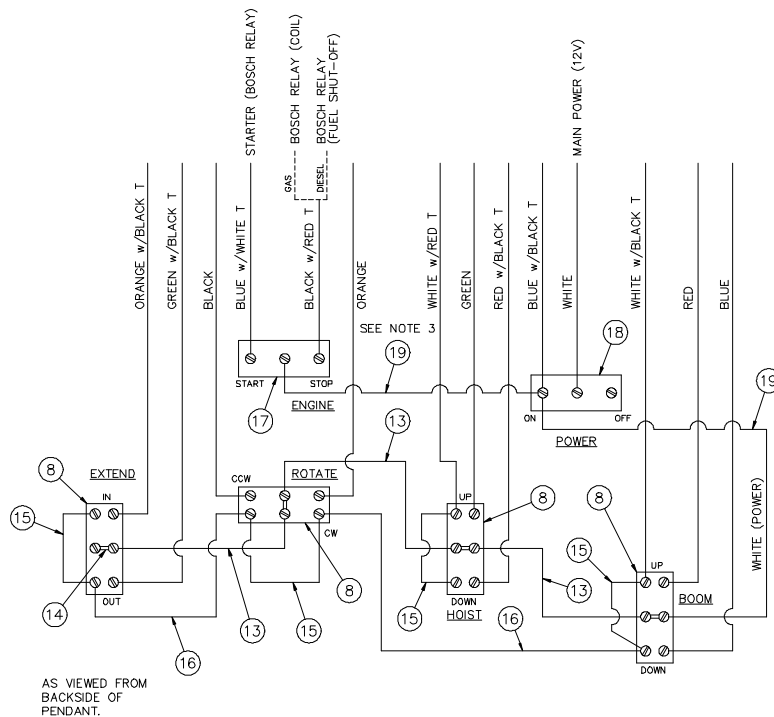
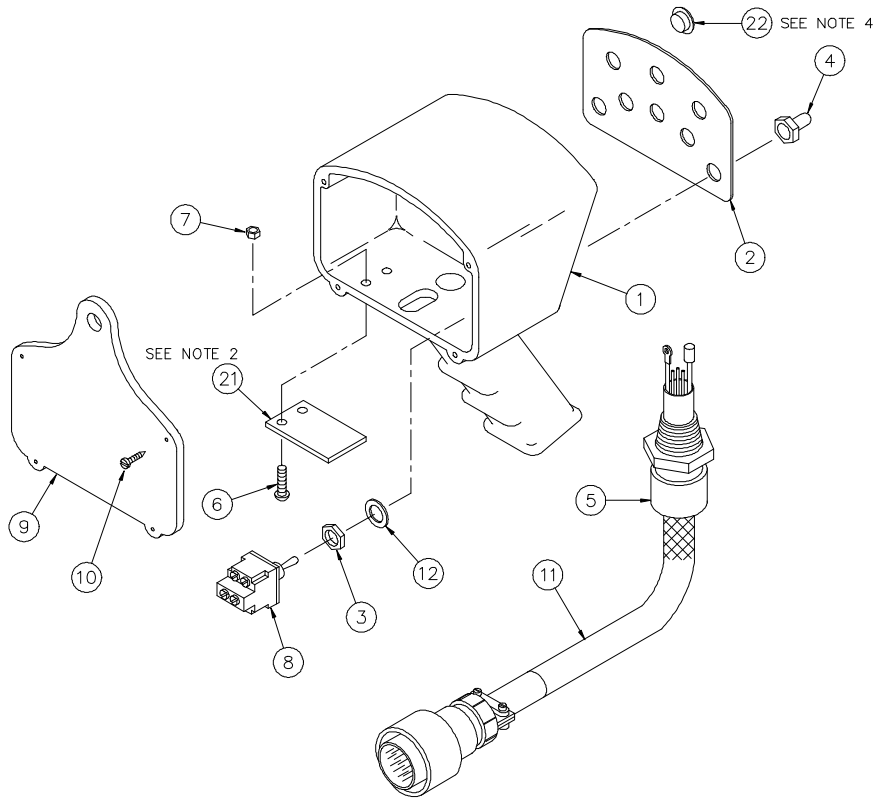

# PENDANT

P/N 680050

<u>ITEM</u>	<u>QTY</u>	<u>P/N</u>	<u>DESCRIPTION</u>
1	1	-	PENDANT HOUSING
2	1	-	DECAL/COVER PLATE
3	6	-	NUT
4	6	-	TOGGLE BOOT
5	1	480567	HUBBELL CONNECTOR CORD GRIP
6	2	-	CAPSCREW #10-24 NC x 3/4
7	2	-	HEX LOCK NUT #10-24 NC
8	4	-	TOGGLE DPDT SWITCH
9	1	-	HOUSING BACK PLATE
10	4	-	SELF THREADING ROUND HEAD SCREW #6 x 3/4
11	1	680041	BAYONET CABLE ASSEMBLY
12	6	-	LOCK WASHER
13	3	660302	CONDUCTOR ASSEMBLY
14	4	636600	JUMPER
15	4	622346	CONDUCTOR ASSEMBLY
16	2	622347	CONDUCTOR ASSEMBLY
17	1	-	TOGGLE SPDT SWITCH
18	1	-	TOGGLE ON/OFF SWITCH
19	1	480526	CONDUCTOR ASSEMBLY
20	2	750737	CABLE TIE
21	1	-	TRIGGER OPENING COVER
22	2	-	PLASTIC 1/2" PLUG (see note 4)

## NOTES:

1. Tie-off the following unused conductors with Item #20 inside of pendnat.  
Blue w/ Red T    Orange w/ Red T    Black w/ White T
2. Before installing Item #21 (Cover), add RTV Sealant between cover & Pendant Housing.
3. Securely wrap unused power connector terminals (Ref. Item #19) with electrical tape; terminals must be unwrapped when adding switches for options.
4. Item #22 (Plastic Plugs) are to be installed in any unused holes in Cover Plate Item #2.
5. Items 3, 4, 8, & 12 may be purchased as a **REPLACEMENT DPDT SWITCH KIT** using **P/N 380005**.
6. Items 3, 4, 12, & 18 may be purchased as a **REPLACEMENT ON/OFF SWITCH KIT** using **P/N 380001**.
7. Items 1, 2, 6, 7, 9, 10, 21, & 22 may be purchased as a **REPLACEMENT HOUSING KIT** using **P/N 380002**.
8. Items 3, 4, 12, & 17 may be purchased as a **REPLACEMENT SPDT KIT** using **P/N 380004**.

# PENDANT

P/N 680008

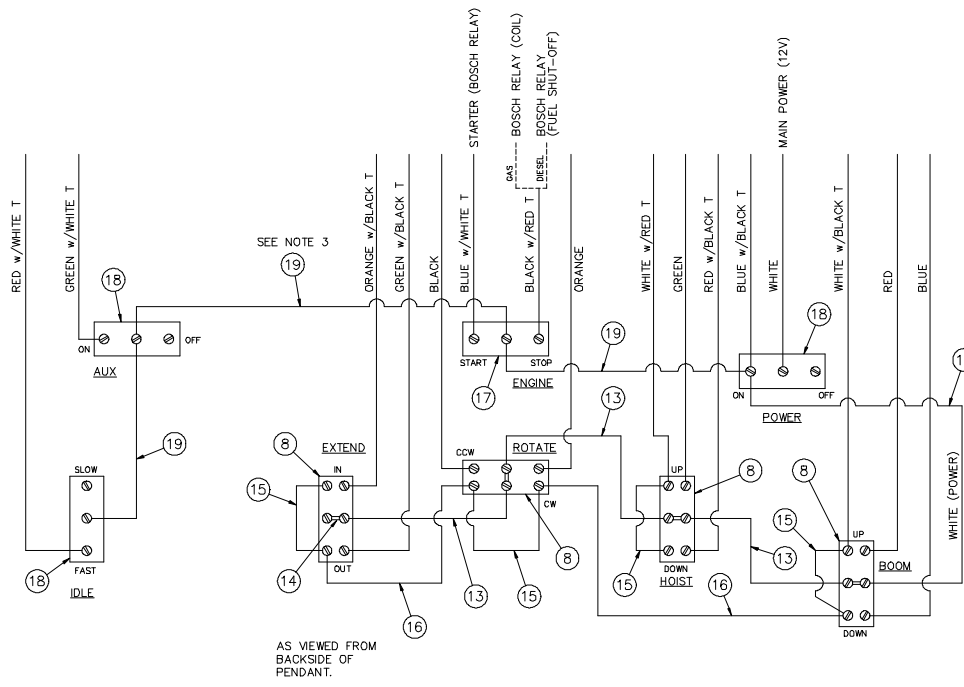
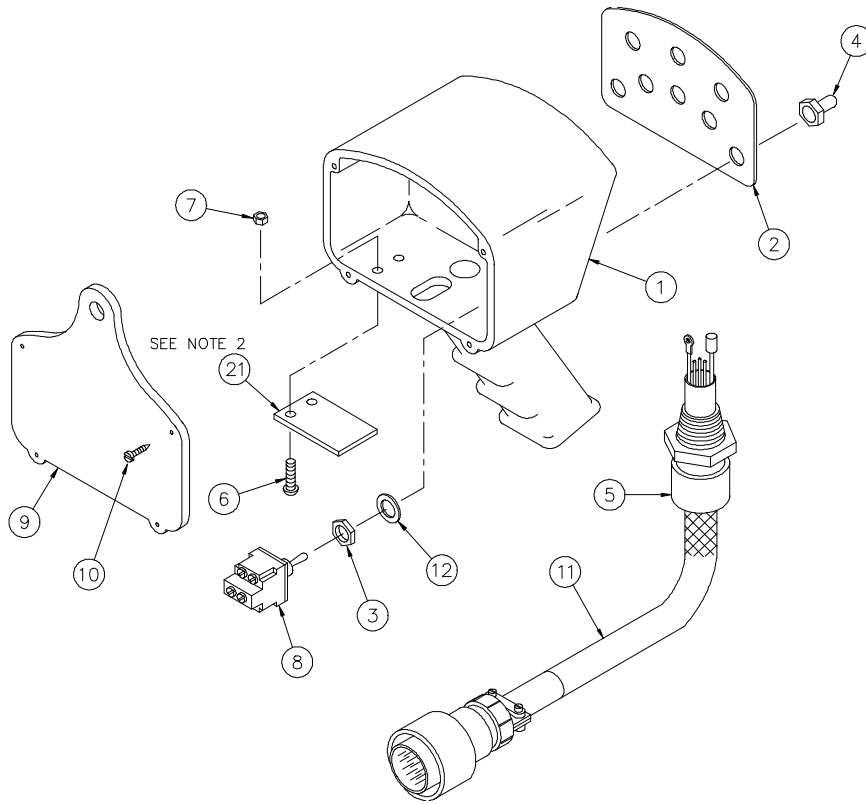

# *PENDANT*

*P/N 680008*

<u>ITEM</u>	<u>QTY</u>	<u>P/N</u>	<u>DESCRIPTION</u>
1	1	-	PENDANT HOUSING
2	1	-	DECAL/COVER PLATE
3	6	-	NUT
4	8	-	TOGGLE BOOT
5	1	480567	HUBBELL CONNECTOR CORD GRIP
6	2	-	CAPSCREW #10-24 NC x 3/4
7	2	-	HEX LOCK NUT #10-24 NC
8	4	-	TOGGLE DPDT SWITCH
9	1	-	HOUSING BACK PLATE
10	4	-	SELF THREADING ROUND HEAD SCREW #6 x 3/4
11	1	680041	BAYONET CABLE ASSEMBLY
12	6	-	LOCK WASHER
13	3	660302	CONDUCTOR ASSEMBLY
14	4	636600	JUMPER
15	4	622346	CONDUCTOR ASSEMBLY
16	2	622347	CONDUCTOR ASSEMBLY
17	1	-	TOGGLE SPDT SWITCH
18	3	-	TOGGLE ON/OFF SWITCH
19	1	480526	CONDUCTOR ASSEMBLY
20	2	750737	CABLE TIE
21	1	-	TRIGGER OPENING COVER

## NOTES:

1. Tie-off the following unused conductors with Item #20 inside of pendnat.  
Blue w/ Red T    Orange w/ Red T    Black w/ White T
2. Before installing Item #21 (Cover), add RTV Sealant between cover & Pendant Housing.
3. Securely wrap unused power connector terminals (Ref. Item #19) with electrical tape; terminals must be unwrapped when adding switches for options.
4. Items 3, 4, 8, & 12 may be purchased as a **REPLACEMENT DPDT SWITCH KIT** using **P/N 380005**.
5. Items 3, 4, 12, & 18 may be purchased as a **REPLACEMENT ON/OFF SWITCH KIT** using **P/N 380001**.
6. Items 1, 2, 6, 7, 9, 10, & 21 may be purchased as a **REPLACEMENT HOUSING KIT** using **P/N 380002**.
7. Items 3, 4, 12, & 17 may be purchased as a **REPLACEMENT SPDT KIT** using **P/N 380004**.

# PENDANT

P/N 680009

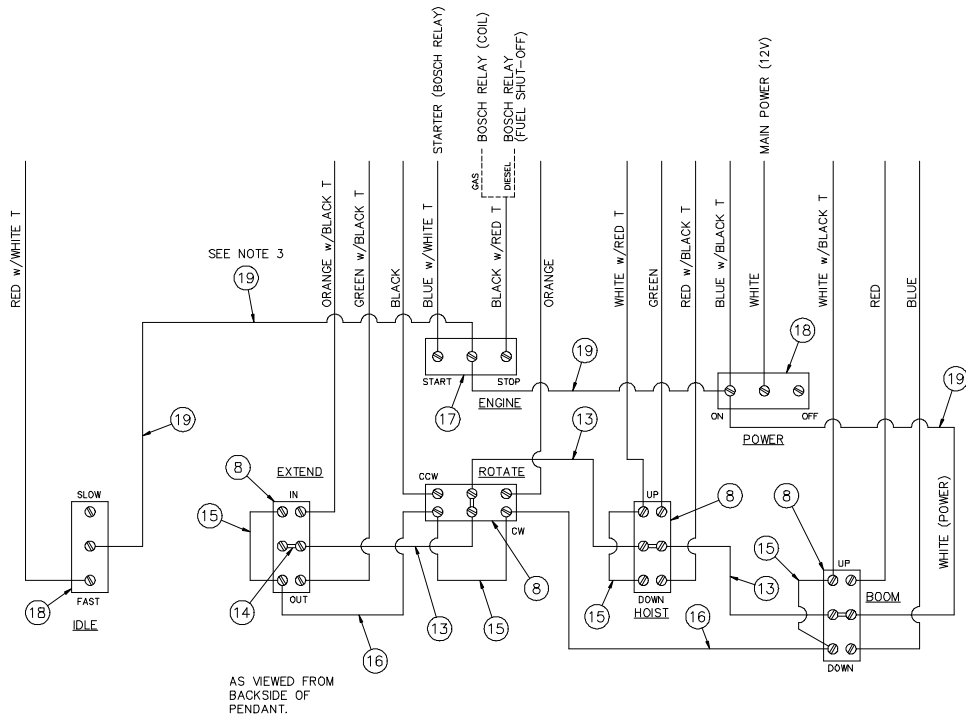
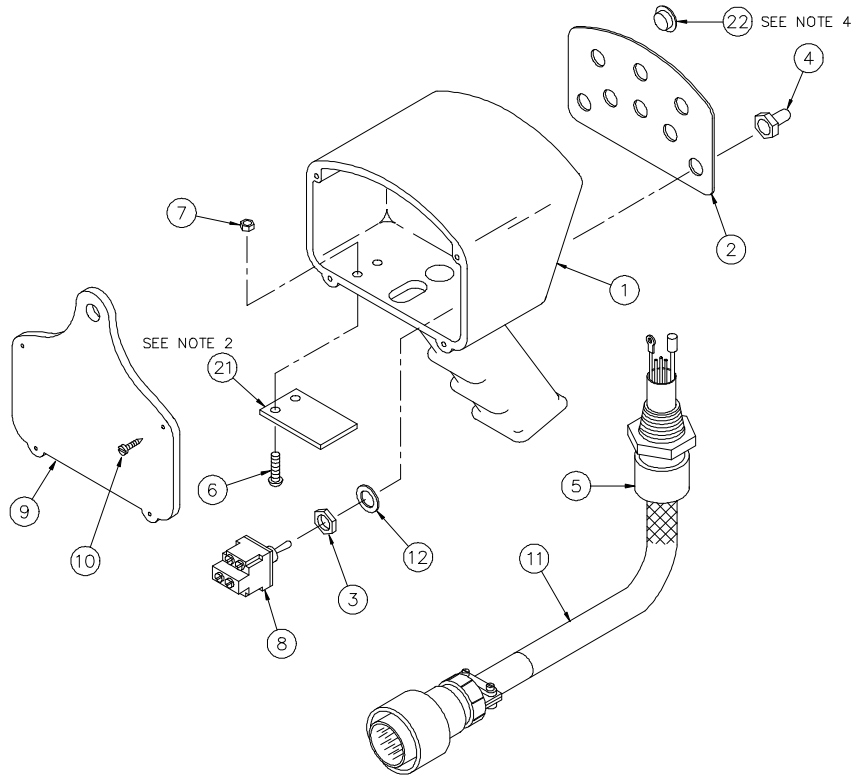

# PENDANT

P/N 680009

<u>ITEM</u>	<u>QTY</u>	<u>P/N</u>	<u>DESCRIPTION</u>
1	1	-	PENDANT HOUSING
2	1	-	DECAL/COVER PLATE
3	6	-	NUT
4	6	-	TOGGLE BOOT
5	1	480567	HUBBELL CONNECTOR CORD GRIP
6	2	-	CAPSCREW #10-24 NC x 3/4
7	2	-	HEX LOCK NUT #10-24 NC
8	4	-	TOGGLE DPDT SWITCH
9	1	-	HOUSING BACK PLATE
10	4	-	SELF THREADING ROUND HEAD SCREW #6 x 3/4
11	1	680041	BAYONET CABLE ASSEMBLY
12	6	-	LOCK WASHER
13	3	660302	CONDUCTOR ASSEMBLY
14	4	636600	JUMPER
15	4	622346	CONDUCTOR ASSEMBLY
16	2	622347	CONDUCTOR ASSEMBLY
17	1	-	TOGGLE SPDT SWITCH
18	1	-	TOGGLE ON/OFF SWITCH
19	1	480526	CONDUCTOR ASSEMBLY
20	2	750737	CABLE TIE
21	1	-	TRIGGER OPENING COVER
22	3	-	PLASTIC 1/2" PLUG (see note 4)

## **NOTES:**

1. Tie-off the following unused conductors with Item #20 inside of pendnat.  
Blue w/ Red T    Orange w/ Red T    Black w/ White T
2. Before installing Item #21 (Cover), add RTV Sealant between cover & Pendant Housing.
3. Securely wrap unused power connector terminals (Ref. Item #19) with electrical tape; terminals must be unwrapped when adding switches for options.
4. Item #22 (Plastic Plugs) are to be installed in any unused holes in Cover Plate Item #2.
5. Items 3, 4, 8, & 12 may be purchased as a **REPLACEMENT DPDT SWITCH KIT** using **P/N 380005**.
6. Items 3, 4, 12, & 18 may be purchased as a **REPLACEMENT ON/OFF SWITCH KIT** using **P/N 380001**.
7. Items 1, 2, 6, 7, 9, 10, 21, & 22 may be purchased as a **REPLACEMENT HOUSING KIT** using **P/N 380002**.
8. Items 3, 4, 12, & 17 may be purchased as a **REPLACEMENT SPDT KIT** using **P/N 380004**.

# PENDANT

## P/N 680010

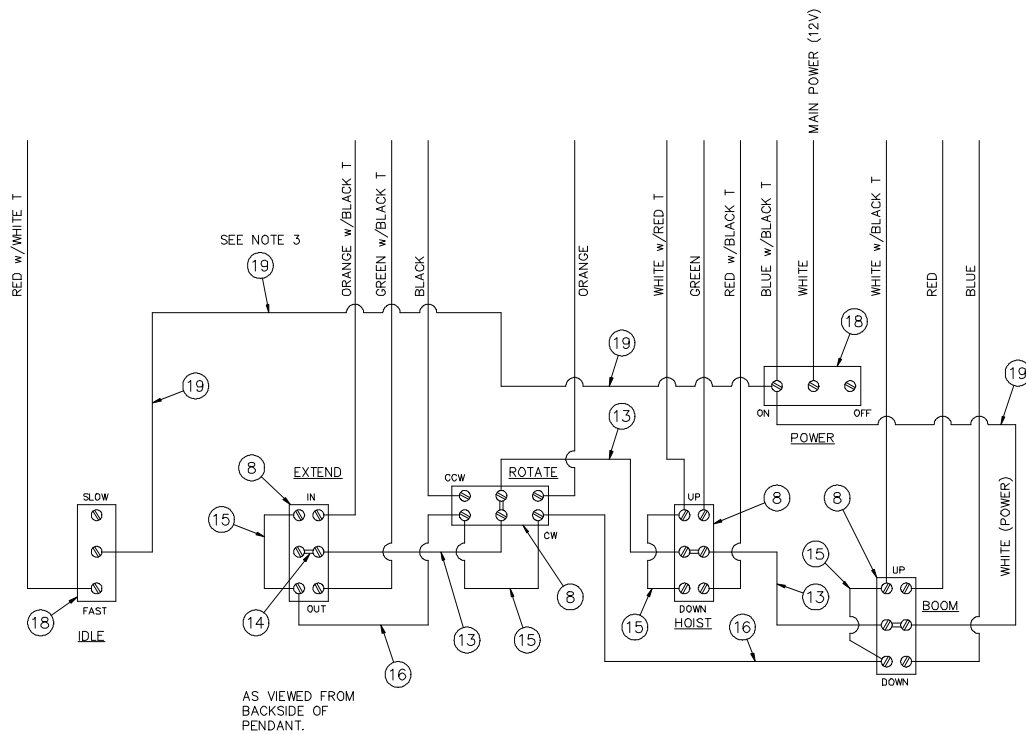
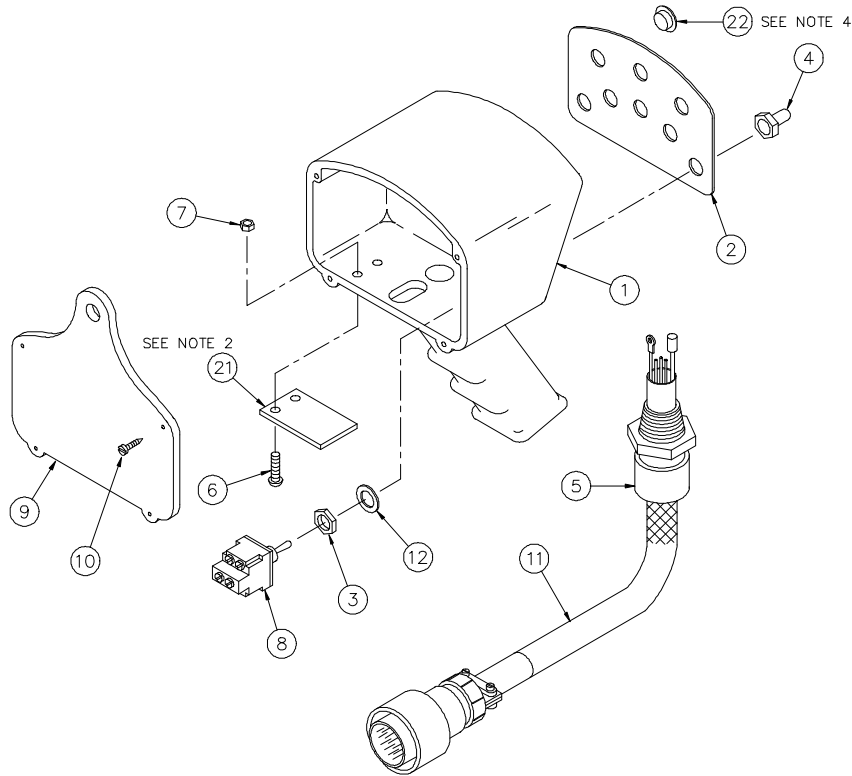

# *PENDANT*

*P/N 680010*

<u>ITEM</u>	<u>QTY</u>	<u>P/N</u>	<u>DESCRIPTION</u>
1	1	-	PENDANT HOUSING
2	1	-	DECAL/COVER PLATE
3	6	-	NUT
4	6	-	TOGGLE BOOT
5	1	480567	HUBBELL CONNECTOR CORD GRIP
6	2	-	CAPSCREW #10-24 NC x 3/4
7	2	-	HEX LOCK NUT #10-24 NC
8	4	-	TOGGLE SWITCH DPDT
9	1	-	HOUSING BACK PLATE
10	4	-	SELF THREADING ROUND HEAD SCREW #6 x 3/4
11	1	680041	BAYONET CABLE ASSEMBLY
12	6	-	LOCK WASHER
13	3	660302	CONDUCTOR ASSEMBLY
14	4	636600	JUMPER
15	4	622346	CONDUCTOR ASSEMBLY
16	2	622347	CONDUCTOR ASSEMBLY
17	-	-	-
18	1	-	TOGGLE ON/OFF SWITCH
19	1	480526	CONDUCTOR ASSEMBLY
20	2	750737	CABLE TIE
21	1	-	TRIGGER OPENING COVER
22	3	-	PLASTIC 1/2" PLUG <i>(see note 4)</i>

## **NOTES:**

1. Tie-off the following unused conductors with Item #20 inside of pendnat.  
Blue w/ Red T    Orange w/ Red T    Black w/ White T
2. Before installing Item #21 (Cover), add RTV Sealant between cover & Pendant Housing.
3. Securely wrap unused power connector terminals (Ref. Item #19) with electrical tape; terminals must be unwrapped when adding switches for options.
4. Item #22 (Plastic Plugs) are to be installed in any unused holes in Cover Plate Item #2.
5. Items 3, 4, 8, & 12 may be purchased as a **REPLACEMENT DPDT SWITCH KIT** using **P/N 380005**.
6. Items 3, 4, 12, & 18 may be purchased as a **REPLACEMENT ON/OFF SWITCH KIT** using **P/N 380001**.
7. Items 1, 2, 6, 7, 9, 10, 21, & 22 may be purchased as a **REPLACEMENT HOUSING KIT** using **P/N 380002**.



# PENDANT

## P/N 680021

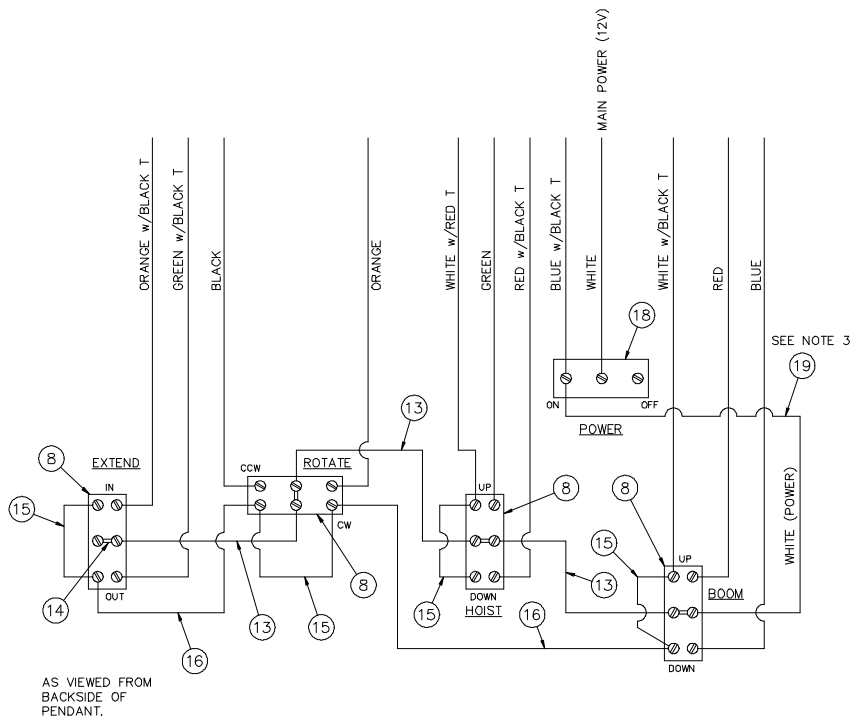
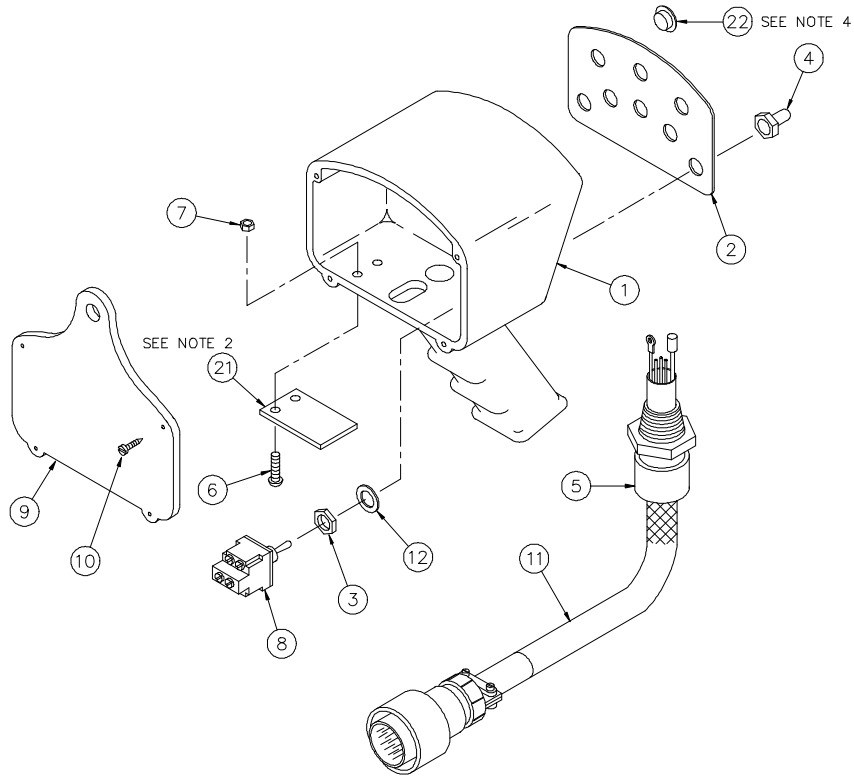

# *PENDANT*

*P/N 680021*

<u>ITEM</u>	<u>QTY</u>	<u>P/N</u>	<u>DESCRIPTION</u>
1	1	-	PENDANT HOUSING
2	1	-	DECAL/COVER PLATE
3	6	-	NUT
4	6	-	TOGGLE BOOT
5	1	480567	HUBBELL CONNECTOR CORD GRIP
6	2	-	CAPSCREW #10-24 NC x 3/4
7	2	-	HEX LOCK NUT #10-24 NC
8	4	-	TOGGLE SWITCH DPDT
9	1	-	HOUSING BACK PLATE
10	4	-	SELF THREADING ROUND HEAD SCREW #6 x 3/4
11	1	680041	BAYONET CABLE ASSEMBLY
12	6	-	LOCK WASHER
13	3	660302	CONDUCTOR ASSEMBLY
14	4	636600	JUMPER
15	4	622346	CONDUCTOR ASSEMBLY
16	2	622347	CONDUCTOR ASSEMBLY
17	-	-	-
18	1	-	TOGGLE ON/OFF SWITCH
19	1	480526	CONDUCTOR ASSEMBLY
20	2	750737	CABLE TIE
21	1	-	TRIGGER OPENING COVER
22	3	-	PLASTIC 1/2" PLUG <i>(see note 4)</i>

## **NOTES:**

1. Tie-off the following unused conductors with Item #20 inside of pendnat.  
Blue w/ Red T    Orange w/ Red T    Black w/ White T
2. Before installing Item #21 (Cover), add RTV Sealant between cover & Pendant Housing.
3. Securely wrap unused power connector terminals (Ref. Item #19) with electrical tape; terminals must be unwrapped when adding switches for options.
4. Item #22 (Plastic Plugs) are to be installed in any unused holes in Cover Plate Item #2.
5. Items 3, 4, 8, & 12 may be purchased as a **REPLACEMENT DPDT SWITCH KIT** using **P/N 380005**.
6. Items 3, 4, 12, & 18 may be purchased as a **REPLACEMENT ON/OFF SWITCH KIT** using **P/N 380001**.
7. Items 1, 2, 6, 7, 9, 10, 21, & 22 may be purchased as a **REPLACEMENT HOUSING KIT** using **P/N 380002**.

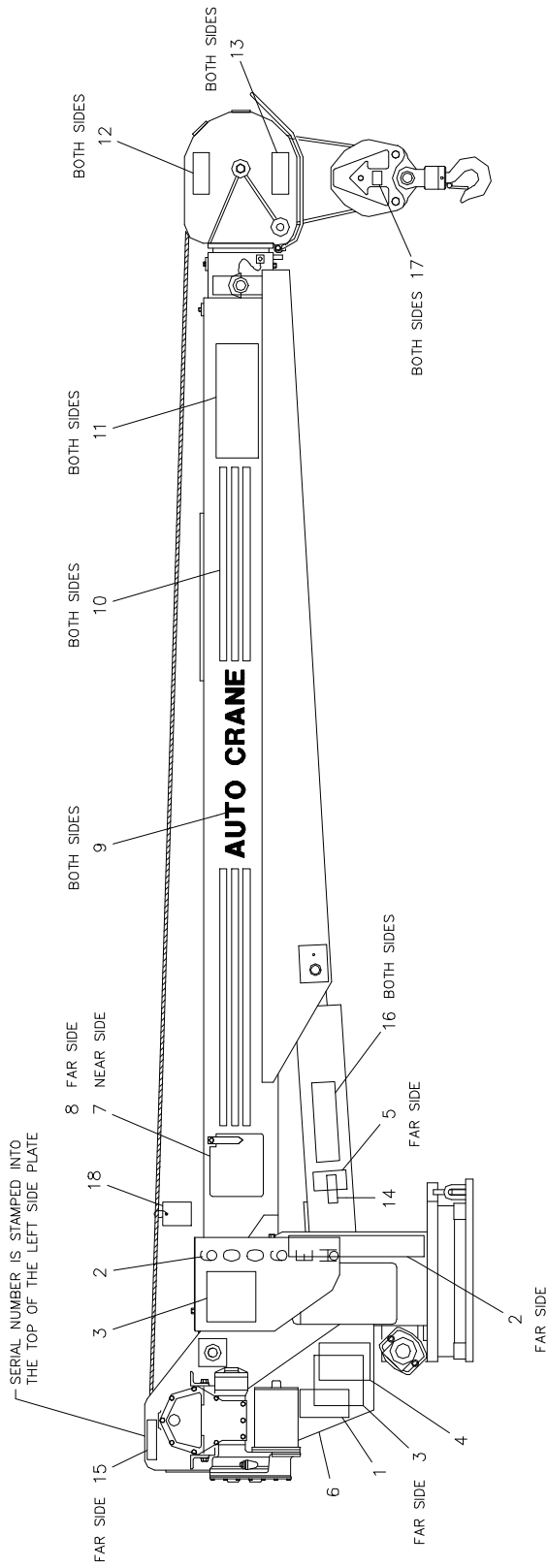

AW-399  
6006EH DECAL LAYOUT (BLUE)  
10-16-20 BOOM

ITEM	QTY	PART NO.	DESCRIPTION	ITEM	QTY	PART NO.	DESCRIPTION
1	1	040579	DECAL, CAUTION-WORK RULES	10	13'	040620	STRIPING
2	2	366804	DECAL, 6006EH	11	2	040529	DECAL, DANGER-SHOCK
3	1	366803	DECAL, LOAD CHART	12	2	040517	DECAL, DANGER-STAY CLEAR OF BOOM
4	1	040580	DECAL, DANGER-OPERATE	13	2	040518	DECAL, DANGER-STAY CLEAR OF LOAD
5	1	040632	DECAL, DANGER-CYL. OPERATION	14	1	040587	DECAL, WARNING-LOAD SENSOR
6	1	360034	DECAL, LOGO	15	1	330622	DECAL, SERIAL NO.
7	1	360036	DECAL, ANGLE INDICATOR, RIGHT	16	1	040519	DECAL, DANGER-SCISSORS POINT
8	1	360037	DECAL, ANGLE INDICATOR, LEFT	17	2	366063-100	DECAL, MAX. LOAD
9	2	040624	DECAL, AUTO CRANE	18	2	366811	DECAL, CHECKLIST 6006EH

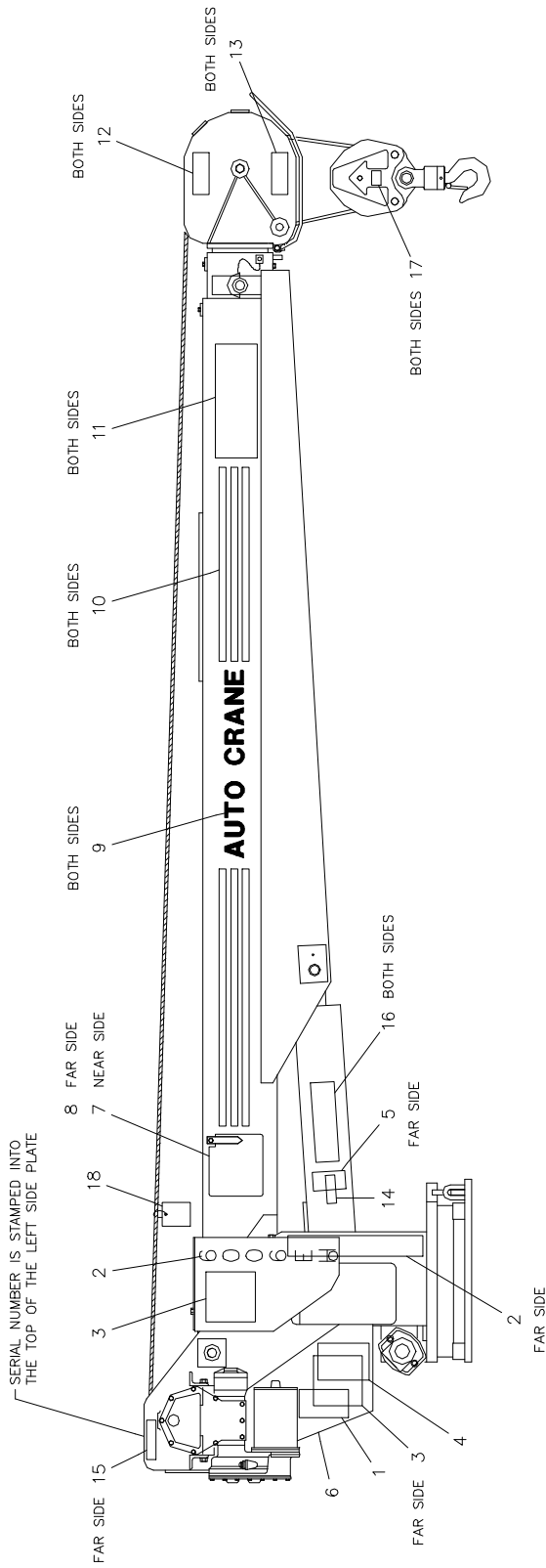

AW-395  
6006EH DECAL LAYOUT (BLACK)  
10-16-20 BOOM

ITEM	QTY	PART NO.	DESCRIPTION	ITEM	QTY	PART NO.	DESCRIPTION
1	1	040579	DECAL, CAUTION-WORK RULES	10	13'	040620-100	STRIPING
2	2	366804-100	DECAL, 6006EH	11	2	040529	DECAL, DANGER-SHOCK
3	1	366803-100	DECAL, LOAD CHART	12	2	040517	DECAL, DANGER-STAY CLEAR OF BOOM
4	1	040580	DECAL, DANGER-OPERATE	13	2	040518	DECAL, DANGER-STAY CLEAR OF LOAD
5	1	040632	DECAL, DANGER-CYL. OPERATION	14	1	040587	DECAL, WARNING-LOAD SENSOR
6	1	360034-100	DECAL, LOGO	15	1	330622-100	DECAL, SERIAL NO.
7	1	360036-100	DECAL, ANGLE INDICATOR, RIGHT	16	1	040519	DECAL, DANGER-SCISSORS POINT
8	1	360037-100	DECAL, ANGLE INDICATOR, LEFT	17	2	366063-100	DECAL, MAX. LOAD
9	2	040624-100	DECAL, AUTO CRANE	18	2	366811	DECAL, CHECKLIST 6006EH

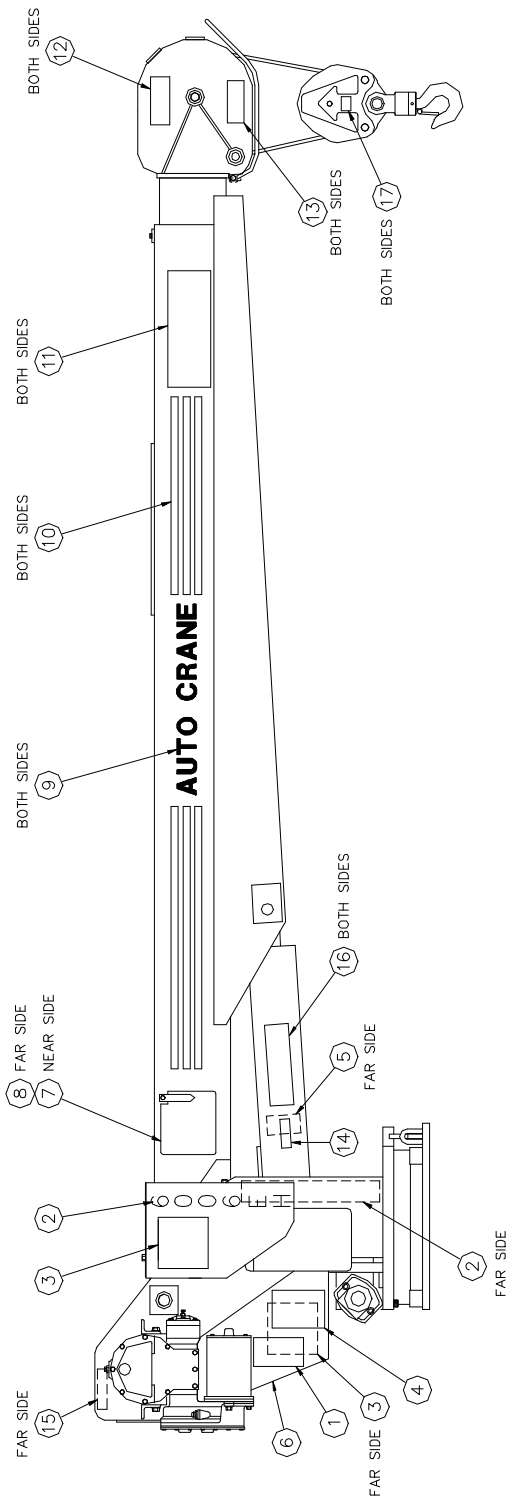

AW-397  
 6006EH DECAL LAYOUT (BLUE)  
 10-16 BOOM

ITEM	QTY	PART NO.	DESCRIPTION	ITEM	QTY	PART NO.	DESCRIPTION
1	1	040579	DECAL, CAUTION-WORK RULES	10	13'	040620	STRIPING
2	2	366804	DECAL, 6006EH	11	2	040529	DECAL, DANGER-SHOCK
3	1	366807	DECAL, LOAD CHART	12	2	040517	DECAL, DANGER-STAY CLEAR OF BOOM
4	1	040580	DECAL, DANGER-OPERATE	13	2	040518	DECAL, DANGER-STAY CLEAR OF LOAD
5	1	040632	DECAL, DANGER-CYL. OPERATION	14	1	040587	DECAL, WARNING-LOAD SENSOR
6	1	360034	DECAL, LOGO	15	1	330622	DECAL, SERIAL NO.
7	1	360036	DECAL, ANGLE INDICATOR, RIGHT	16	1	040519	DECAL, DANGER-SCISSORS POINT
8	1	360037	DECAL, ANGLE INDICATOR, LEFT	17	2	366063-100	DECAL, MAX. LOAD
9	2	040624	DECAL, AUTO CRANE	18	2	366811	DECAL, CHECKLIST 6006EH

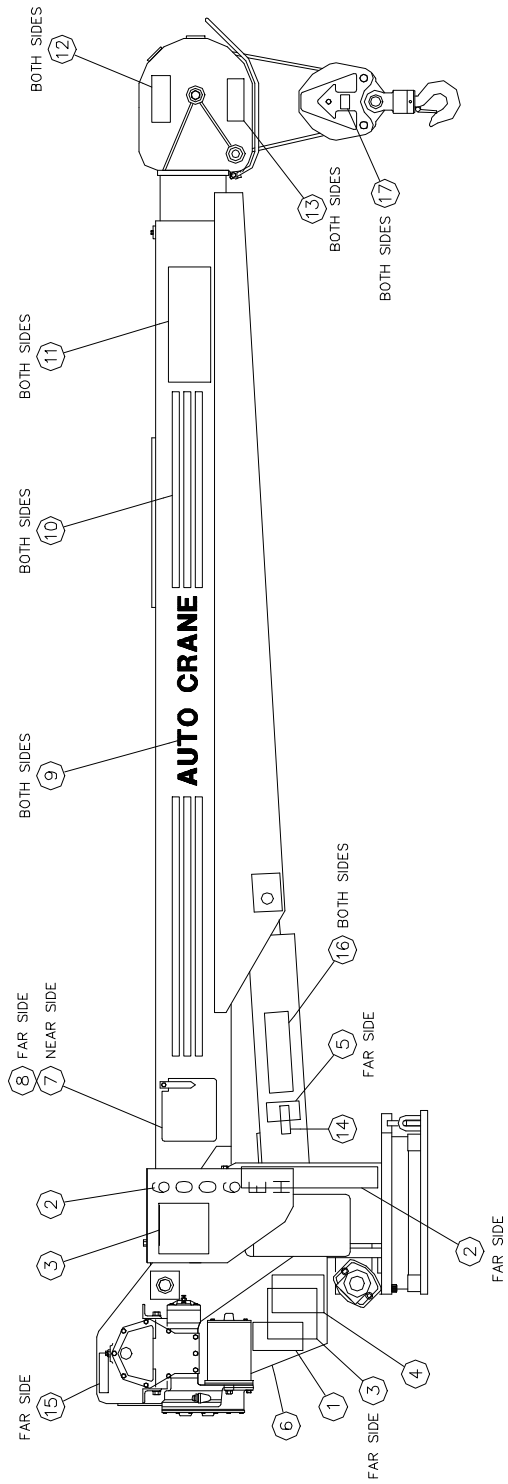

AW-398  
 6006EH DECAL LAYOUT (BLACK)  
 10-16 BOOM

ITEM	QTY	PART NO.	DESCRIPTION	ITEM	QTY	PART NO.	DESCRIPTION
1	1	040579	DECAL, CAUTION-WORK RULES	10	13'	040620-100	STRIPING
2	2	366804-100	DECAL, 6006EH	11	2	040529	DECAL, DANGER-SHOCK
3	1	366807-100	DECAL, LOAD CHART	12	2	040517	DECAL, DANGER-STAY CLEAR OF BOOM
4	1	040580	DECAL, DANGER-OPERATE	13	2	040518	DECAL, DANGER-STAY CLEAR OF LOAD
5	1	040632	DECAL, DANGER-CYL. OPERATION	14	1	040587	DECAL, WARNING-LOAD SENSOR
6	1	360034-100	DECAL, LOGO	15	1	330622-100	DECAL, SERIAL NO.
7	1	360036-100	DECAL, ANGLE INDICATOR, RIGHT	16	1	040519	DECAL, DANGER-SCISSORS POINT
8	1	360037-100	DECAL, ANGLE INDICATOR, LEFT	17	2	366063-100	DECAL, MAX. LOAD
9	2	040624-100	DECAL, AUTO CRANE	18	2	366811	DECAL, CHECKLIST 6006EH

# AUTOMATIC SAFETY BRAKE ASSEMBLY (OIL COOLED) HOIST

1. WINCH HAS RIGHT HAND WORM AND GEAR AND SPOOLS OVER DRUM; USE #1 SLOTS FOR BRAKE BALLS.
2. INSTALL BRAKE HUB ON WINCH WORM WITH KEY.
3. ASSEMBLE BALLS IN CAM USING HARD GREASE TO HOLD BALLS IN PLACE.
4. INSTALL CAM AND BALLS, FITTING BALLS IN SLOTS ON HUB.
5. INSTALL BRAKE DISK
6. INSTALL RETAINER.
7. INSTALL FLAT SPRING IN BRAKE HOUSING COVER (ARCH DOWN).
8. INSTALL BRAKE HOUSING COVER, FITTING PINS IN SLOTS ON SPRING AND HOLES IN RETAINER.
9. TEST BRAKE BY SHIFTING WINCH TO UP THEN DOWN TO SEE IF BRAKE IS WORKING IN PROPER ROTATION. IF NOT, REMOVE BRAKE AND LOCATE BRAKE BALLS IN OPPOSITE SET OF SLOTS.
10. ADJUST TO SUIT BY TIGHTENING OR LOOSENING SCREW ON OUTSIDE OF COVER. WHEN PROPER ADJUSTMENT IS OBTAINED, SECURE SCREW WITH JAM NUT.

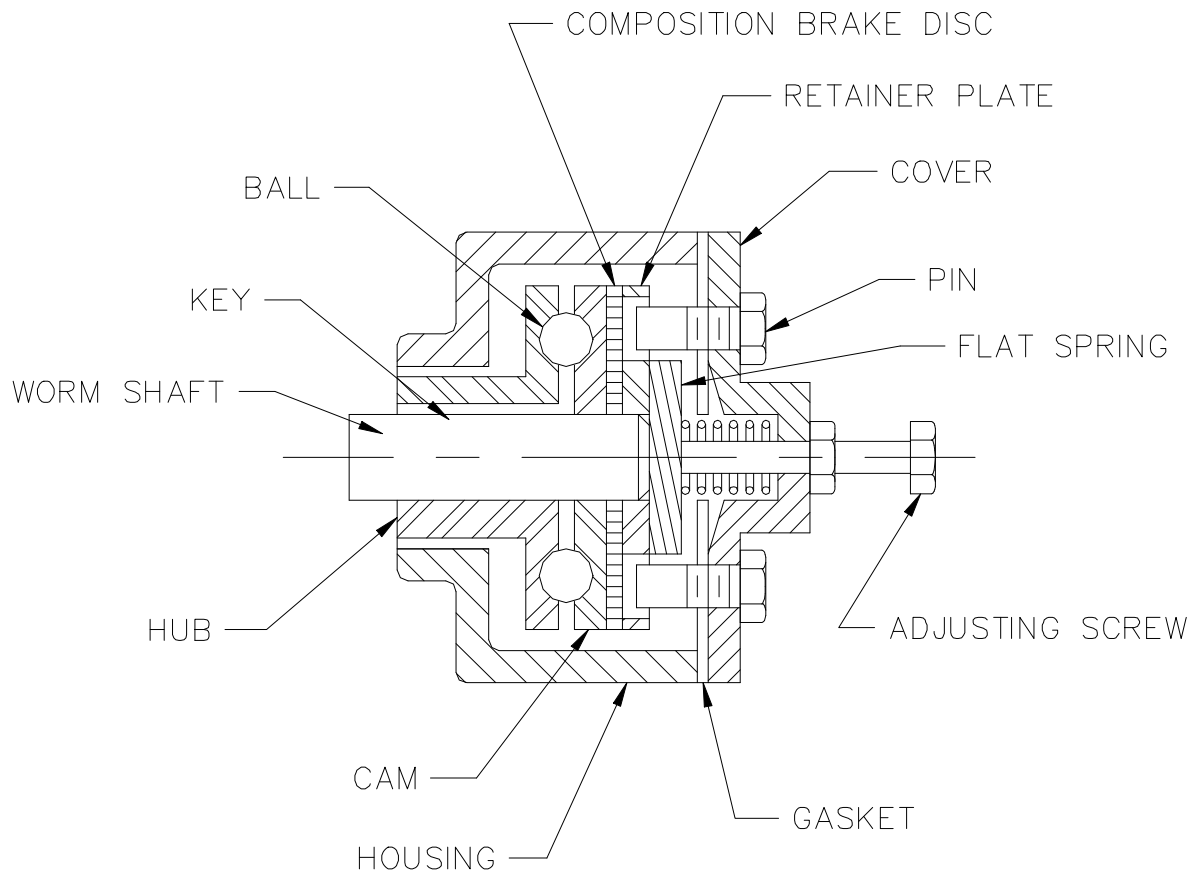

AW-394

27-0.0.0

7/96

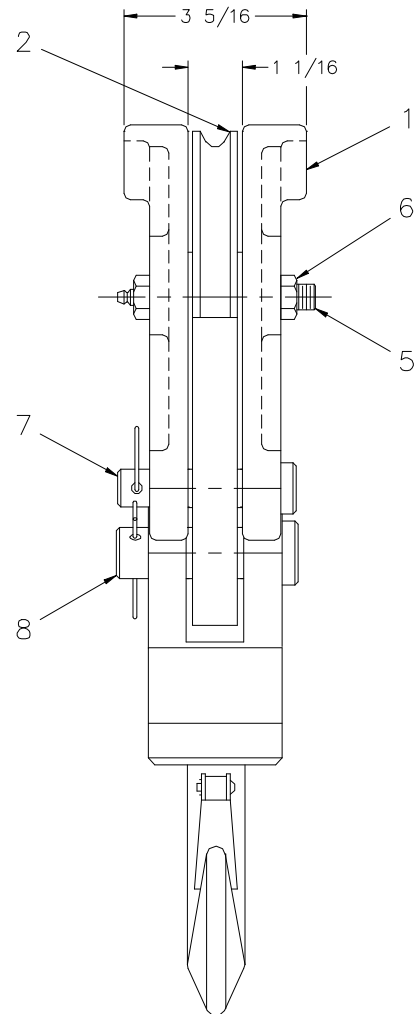
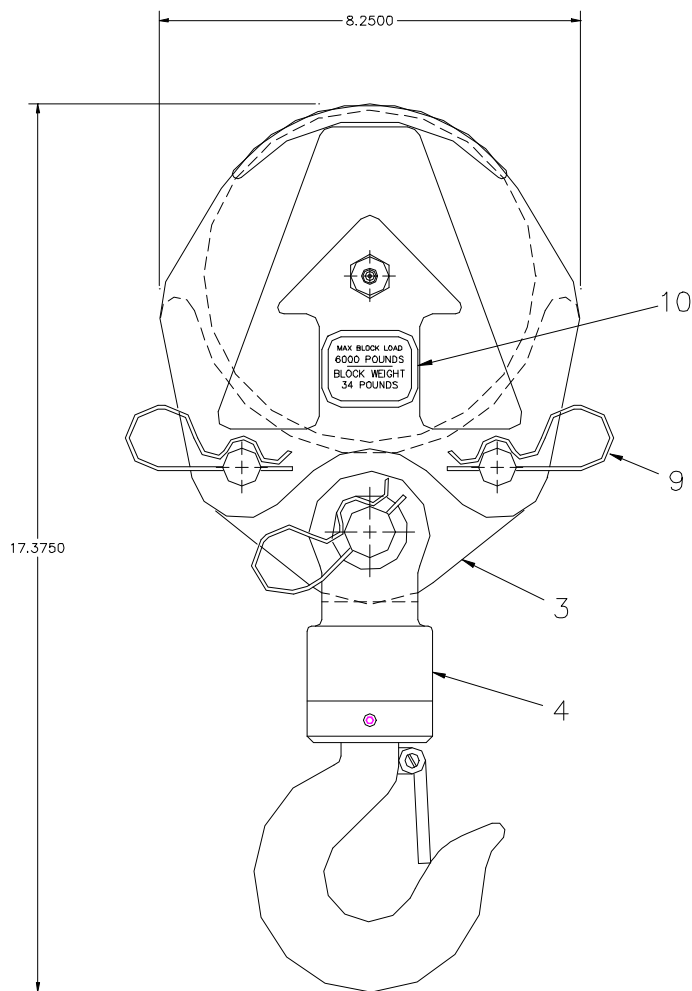

ITEM	QTY	P/N	DESCRIPTION	ITEM	QTY	P/N	DESCRIPTION
1	2	480362	SIDE PLATE (MACH.)	6	1	017800	NUT, HX LK 1/2-20NF
2	1	480130	SHEAVE ASSEMBLY	7	2	480367	PIN, BLOCK
3	1	480364	TACKLE, LOWER	8	1	480368	PIN, SWIVEL HOOK
4	1	480371	HOOK, SWIVEL - 3 TON	9	3	360124	PIN, HITCH (HAIR PIN)
5	1	480372	BOLT, SHEAVE w/ ZERK	10	2	366063-100	DECAL, MAX. LOAD

**AW-366063**  
**TRAVELING BLOCK ASSEMBLY**  
**6006H (SHORT)**



# 6006EH 10-16-20 MAXIMUM LOAD CHART

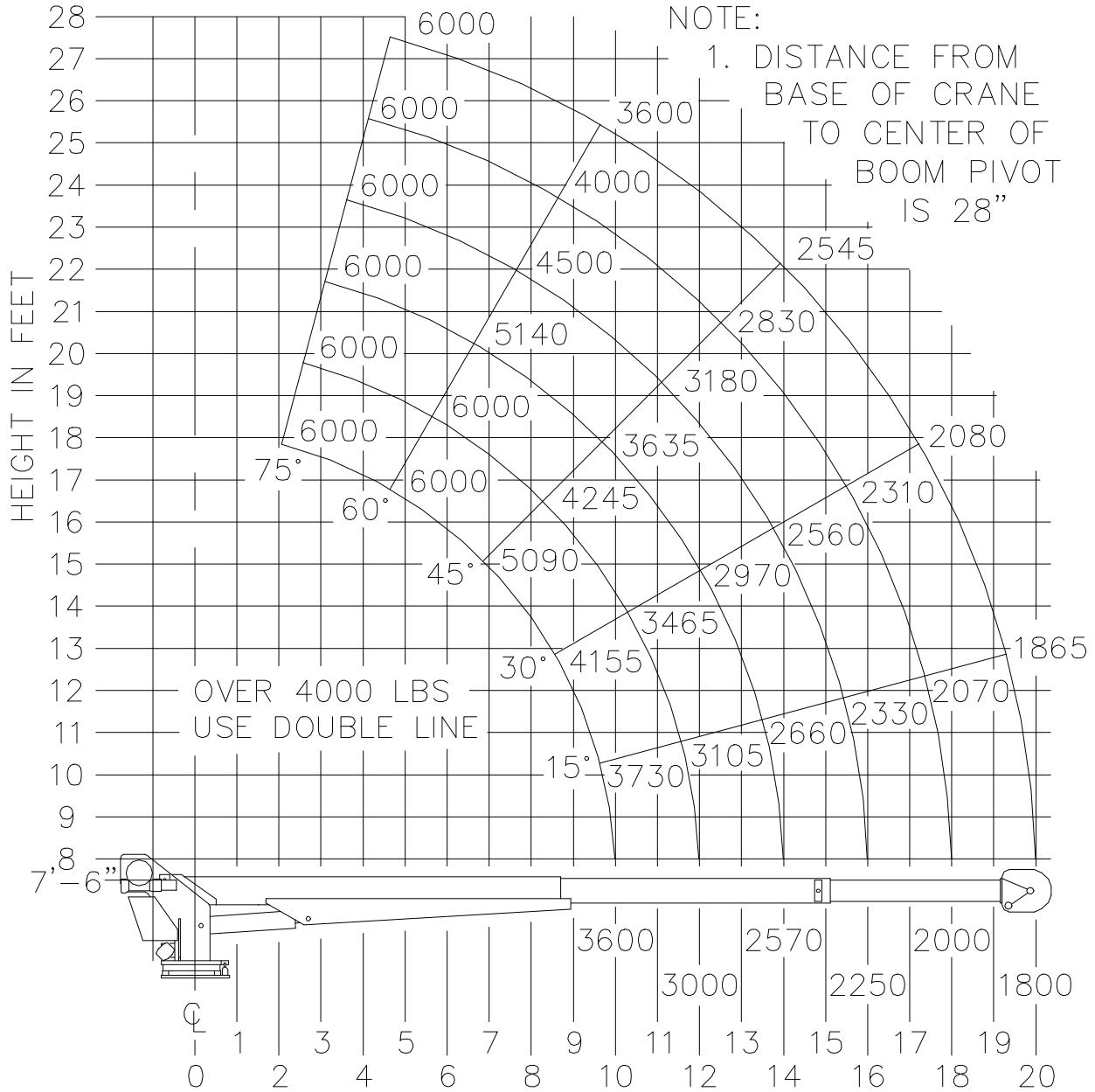

AW-388  
6006EH LOAD CHART  
10-16-20 BOOM

# 6006EH 10-16 MAXIMUM LOAD CHART

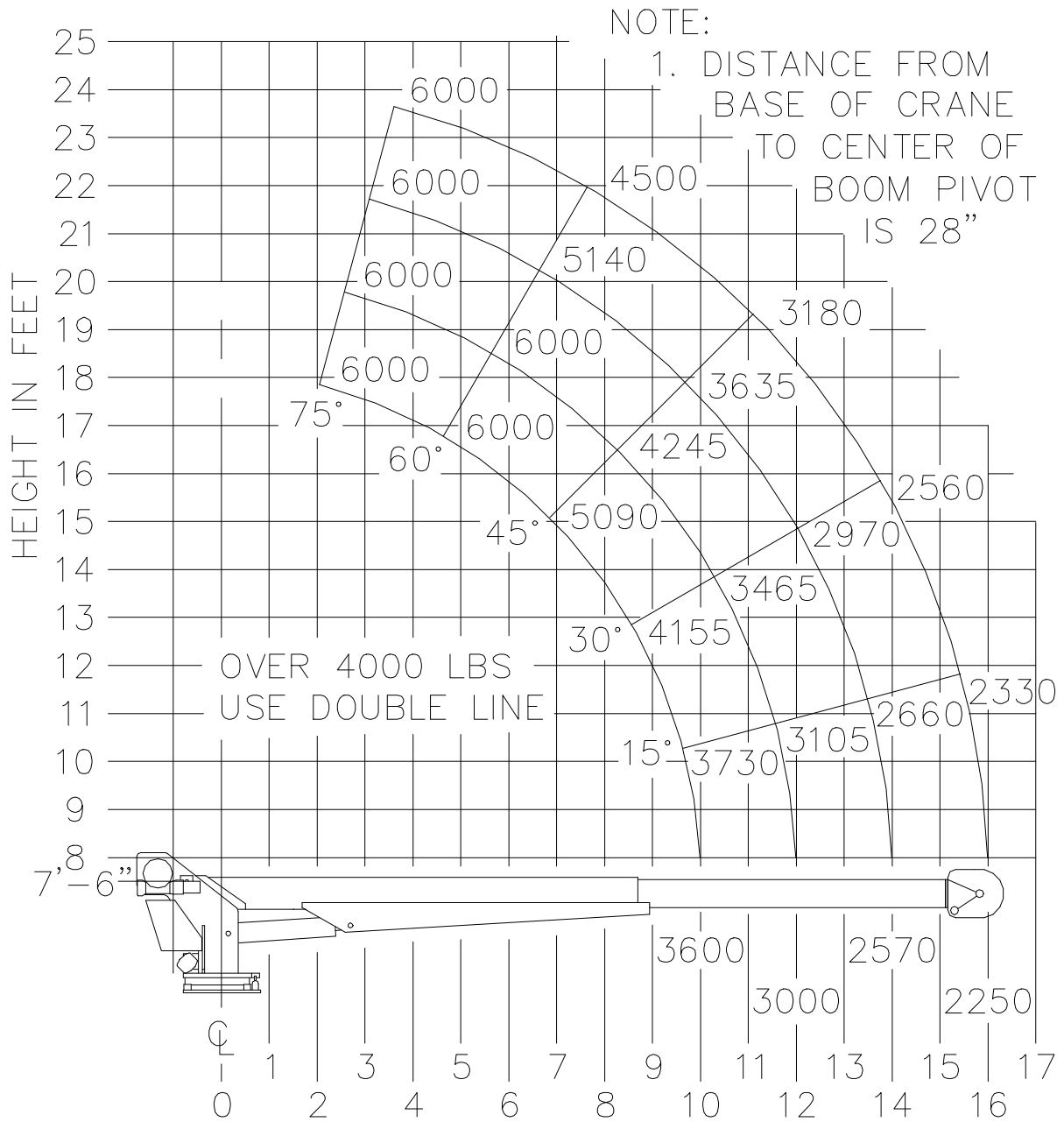

AW-387  
6006EH LOAD CHART  
10-16 BOOM



## **AUTO CRANE COMPANY**

P. O. BOX 581510 • TULSA, OKLAHOMA 74158

# Limited Warranty

Auto Crane will warranty to consumer for a period of twelve months from date of purchase that each new Auto Crane product it sells will be free under normal use and service, from defects in material and workmanship. Date of purchase will be honored as either date of purchase by distributor or his date of sale of the product as substantiated by Distributor Delivery Report.

Obligation of Auto Crane under this warranty is limited to replacement or repair of parts that appear to manufacturer after review and/ or inspection to be defective. This warranty does not obligate Auto Crane to bear the cost of labor or transportation charges in connection with the replacement or repair of defective parts. Responsibility for customer's claims arising from misapplication, abuse, misuse or alteration of equipment or parts lies with the distributor or user and no warranty obligation is assumed in the circumstances by Auto Crane.

Auto Crane will in no event be liable for any consequential damages or contingent liabilities arising out of the failure of any Auto Crane product or parts to operate properly.

Auto Crane makes no warranty in respect to component accessories, same being subject to the warranties of their respective manufacturers.

If field service, at the request of buyer, is rendered and fault is found not to be with Auto Crane's product, the buyer shall pay the time and expense of the field representative. Claims for service labor or other expenses that have been incurred by the buyer without approval or authorization of Auto Crane will not be accepted.

AUTO CRANE COMPANY IS UNDER NO OBLIGATION TO EXTEND THIS WARRANTY TO ANY CUSTOMER FOR WHICH AN AUTO CRANE WARRANTY REGISTRATION CARD HAS NOT BEEN COMPLETED AND MAILED TO AUTO CRANE COMPANY WITHIN FIFTEEN (15) DAYS AFTER DATE OF PURCHASE.