

OWNERS MANUAL

4004H

REVISION 2/2000

PART NO. 999997

SERIAL NO. _____

AUTO CRANE COMPANY

PO BOX 580697, TULSA, OK 74158-0697
4707 N. MINGO ROAD, TULSA, OK 74117-5904
PHONE (918) 836-0463
FAX (918) 834-5979
<http://www.autocrane.com>

!! DISTRIBUTORS !!

**PROTECT YOUR CUSTOMER'S WARRANTY!
SUBMIT DELIVERY REPORT WITHIN 15 DAYS.**

Mail to: Auto Crane Company
P.O. Box 580697
Tulsa, OK 74158-0697

Or Fax to: 918/834-5979

Protect your customers warranty - Submit within 15 days from delivery date.



AUTO CRANE COMPANY

**DISTRIBUTOR
DELIVERY REPORT**

DISTRIBUTOR _____		OWNER _____	
ADDRESS _____		CITY/STATE _____	
CITY/STATE/ZIP _____		BUSINESS _____	
MODEL #	SERIAL #	DATE DELIVERED	UNIT DESTINATION

IMPORTANT: ATTACH SIGNED COPY OF CUSTOMER INVOICE / DELIVERY RECEIPT

AC-109 REPORT AUTHORIZED BY: _____

*** REGISTER ONE UNIT ONLY PER CARD ***

WARNINGS - READ THIS PAGE!

WARNING! Federal law (49 cfr part 571) requires that the Final Stage Manufacturer of a vehicle certify that the vehicle complies with all applicable federal regulations. Any modifications performed on the vehicle prior to the final stage are also considered intermediate stage manufacturing and must be certified as to compliance. The installer of this crane and body is considered one of the manufacturers of the vehicle. As such a manufacturer, the installer is responsible for compliance with all applicable federal and state regulations, and is required to certify that the vehicle is in compliance.

WARNING! It is the further responsibility of the installer to comply with the OSHA Truck Crane Stability Requirements as specified by 29 CFR part 1910.180 (C) (1).

WARNING! NEVER OPERATE THE CRANE NEAR ELECTRICAL POWER LINES! Death or serious injury will result from boom, line, or load contacting electric lines. Do not use crane within 10 feet (3.05m) of electric power lines carrying up to 50,000 volts. One foot additional clearance is required for every additional 30,000 volts or less.

WARNING! NEVER

- v **EXCEED** load chart capacities (centerline of rotation to hoist hook).
- v un-reel last 5 wraps of cable from drum!
- v wrap cable around load!
- v attempt to lift or drag a load from the side! The boom can fail far below its rated capacity.
- v weld, modify, or use unauthorized components on any Auto Crane unit! This will void any warranty or liability. Also failure of the crane may result.
- v place a chain link on the tip of the hook and try to lift a load!
- v use a sling bar or anything larger than the hook throat that could prevent the hook latch from closing, thus negating the safety feature!
- v hold on any pendant Select Switch that will cause unsafe operating conditions!

WARNING! In using a hook with latch, **ALWAYS** make sure that the hook throat is closed before lifting a load! Proper attention and common sense applied to the use of the hoist hook and various slings will prevent possible damage to material being hoisted and may prevent injury to personnel.

WARNING! Failure to correctly plumb and wire crane can cause inadvertent operation and damage to crane and/or personnel!

WARNING! Auto Crane Company remote controlled cranes are not designed or intended to be used for any applications involving the lifting or moving of personnel.

WARNING! ALWAYS operate the crane in compliance with the load capacity chart. **Do not use** the overload shutdown device to determine maximum rated loads, if your crane is equipped with this type of device.

4004H SERIES - OWNER'S MANUAL
TABLE OF CONTENTS

	PAGE
1 INTRODUCTION	1-1.0.0
2 OPERATING PRACTICES & WARNINGS	1-2.0.0
3 OPERATION OF UNIT / OUTRIGGERS	1-3.0.0
4 QUALIFICATIONS FOR OPERATORS	1-4.0.0
5 INSPECTION, TESTING, & MAINTENANCE	1-5.0.0
6 LIFE OF WIRE LINE / WIRE LINE LUBRICATION	1-6.0.0
7 SAFETY DECAL SECTION	1-7.0.0
8 LUBRICATION & MAINTENANCE SCHEDULE	1-8.0.0
9 INSTALLATION	2-1.0.0
10 GENERAL ASSEMBLY (PEDESTAL)	3-1.0.0
11 2-BLOCK ASSEMBLY	3-4.0.0
12 HOIST ACTUATOR ASSEMBLY	3-5.0.0
13 AUTOMATIC SAFETY BRAKE	3-6.0.0
14 TURNER ASSEMBLY	3-7.0.0
15 TRAVELING BLOCK ASSEMBLY	3-8.0.0
16 GENERAL DIMENSIONS	4-1.0.0
17 ELECTRICAL SECTION	5-1.0.0
18 HYDRAULIC SECTION	6-1.0.0
19 LOAD CHART	9-1.0.0
20 WARRANTY	LAST PAGE

GENERAL SPECIFICATIONS

4004H SERIES

DIMENSIONS

Width: 19.25 in (.49 m)
Height: 32.50 in (.83 m)
Length: 11 ft 8 5/16 in (3.58 m)
Weight: 1050 lbs (476 kg)
 [Add 5 lbs (2.25 kg) for cable length
 of 75 feet (23 m)]

CAPACITY

16,000 ft lbs (2.31 ton/m)
 [ft lbs = horizontal distance from centerline of
 rotation to free hanging weight (feet) x amount
 of weight (pounds)]

LIFTING CAPACITIES			
ft	lbs	ft	lbs
3	4,000	12	1,333
4	4,000	13	1,231
5	3,200	14	1,143
6	2,666	15	1,067
7	2,286	16	1,000
8	2,000	17	941
9	1,778	18	889
10	1,600	19	842
11	1,455	20	800

REACH

Main boom reaches 10 ft
 Power boom will extend to 16 ft
 Manual boom will extend to 20 ft

CABLE

80 ft (24.3 m) of 5/16 in diameter aircraft
 quality cable is standard [75 ft (22.86 m)
 optional].

CHASSIS REQUIREMENTS

10,500 lbs (4,763 kg) GVWR minimum

HYDRAULIC SYSTEM

Pressure: 2200psi (15,169 kPa) relief setting

Flow: 5 gpm (19 lpm)

Filtration: High pressure 10 micron in
 manifold

Oil Type: 10w Hydraulic Oil
 [Mobile DTE 13, Sun 2015,
 Dextron II]

MOVEMENT SPEEDS:

(Proportional Maximum)

Hoist: 34 fpm single line (no load)
 31 fpm single line (1000 lbs)

Boom Up: 9 sec

Boom Down: 8 sec

Extend Out: 11 sec

Extend In: 9 sec

Rotation: 40 sec/revolution

ELECTRICAL SYSTEM REQUIREMENTS

Control voltage: 12 volt DC

Alternator: 90 amp (minimum)

Battery: 100 minute reserve
 capacity (minimum)
 Maintenance type



INTRODUCTION

4004H SERIES

Auto Crane products are designed to provide many years of safe, trouble-free, dependable service when properly used and maintained.

To assist you in obtaining the best service from your crane and to avoid untimely crane and/or vehicle failure, this manual provides the following operating and service instructions. It is **specifically recommended** that all operating and service personnel consider this manual as mandatory material for reading and study before operating or servicing Auto crane products. It is **highly recommended** that crane owners, equipment managers and supervisors also read this manual.

Auto Crane has incorporated several safety features in the 4004EH series cranes for your protection. The choice of materials and the design of the electrical system minimizes weight and lengthens durability. The hydraulic components meet or exceed a **3.5:1 safety factor**. Holding valves prevent the load from dropping if a hose should fail. The reservoir has a **40 μ air filter** in the filler cap. The pump has a **100 mesh strainer** in the suction line.

For your convenience the overall dimensions of the 4004H series crane are in the General Dimension Section. Maximum turning radius at both the hoist motor and the rotation motor are also on that drawing.

Remember, the crane adds weight to the vehicle. Adding weight may change the driving and riding characteristics of the vehicle unless the appropriate overload spring(s) are installed on the truck. The payload of the vehicle is reduced by the weight of the crane. The operator should exercise care when loading the vehicle. Distributing the payload on the vehicle evenly will greatly improve the driving and riding characteristics of the vehicle. **A minimum G.V.W. of 10,500 lbs. with two rear jacklegs (or outriggers) is recommended for mounting the 4004H series cranes.**

The 4004H series cranes are attached directly to your 12 volt truck electrical system. The power cable and retaining clips are included with the crane. A typical power cable mounting and hookup is shown in the installation section. The performance of your new crane depends on the truck electrical system. The use of maintenance free batteries is **NOT** recommended for use with any Auto Crane product. The recommended alternator and battery that will give the longest life with the most useful duty cycle is a 60 amp. alternator with a 120 minute reserve capacity, deep cycle battery. These specifications should be considered minimum.

Auto Crane Company issues a limited warranty certificate with each unit sold. See last page for warranty policy.

It has always been Auto Crane Company policy to handle all warranty claims we receive as promptly as possible. If a warranty claim involves discrepant material or workmanship, Auto Crane will take immediate corrective action. It is understandable that Auto Crane company cannot assume responsibility of liability when it is obvious that our products have been abused, mis-used, overloaded or otherwise damaged by inexperienced persons trying to operate the equipment without reading the manual.

Auto Crane will not assume responsibility or liability for any modifications or changes made to unit, or installation of component parts done without authorization.

Auto Crane maintains a strong distributor network and a knowledgeable Customer Service Department. In most cases, an equipment problem is solved via phone conversation with our customer service department. The customer service department also has the ability to bring a local distributor, a regional sales manager, or a factory serviceman into the solution of an equipment problem. If, through no fault of Auto crane company, it is necessary to send an experienced factory serviceman on a field service call, the rates stated in the Auto Crane Distributor's Flat Rate Manual will apply.

Auto Crane Company's extensive Research and Development Program allow our customers to use the best equipment on the market. Our Engineering Staff and our knowledgeable sales people, are always available to our customers in solving crane and winch-type application problems. When in doubt, call the Auto Crane factory.

DISTRIBUTOR ASSISTANCE:

Should you require any assistance not given in this manual, we recommend that you consult your nearest Auto Crane Distributor. Our distributors sell authorized parts and have service departments that can solve almost any needed repair.

NOTE: THIS MANUAL SHOULD REMAIN WITH THE CRANE AT ALL TIMES.

This manual does not cover all maintenance, operating, or repair instructions pertinent to all possible situations. If you require additional information, please contact the **Auto Crane Company** at the following telephone number: **(918) 836-0463**. The information contained in the manual is in effect at the time of this printing. Auto Crane Company reserves the right to update this material without notice or obligation.

--- IMPORTANT ---

OPERATING PRACTICES & WARNINGS

1. Make certain the vehicle meets minimum chassis requirements. (These requirements do not guarantee unit stability)
2. Make certain the crane is installed per factory specifications. Contact your local Distributor or the Auto Crane factory if any questions arise.
3. Keep the vehicle in as level a position as possible while loading or unloading.
4. **ALWAYS** set the vehicle emergency brake before beginning crane operations.
5. **ALWAYS** use outriggers from vehicle to the ground during crane operation. Make sure they are firmly positioned on solid footings.
6. All load ratings are based on crane capacity, **NOT** truck/crane stability.
7. Keep objects and personnel clear of crane path during operation.
8. Keep hoist cable pulled tight at all times.
9. **REMEMBER**, in lifting a heavy load, the weight can create enough tipping momentum to overturn the vehicle.
10. **ALWAYS** keep load as close to ground as possible.
11. Oil gears as required.
12. Periodic adjustment of hoist worm brake may be required (see automatic safety brake drawing in this manual).
13. Hydraulic hoses need to be inspected frequently for signs of deterioration, and be replaced as required.
14. The hoist hook is an important item that an operator should consider and use properly. It should be checked on a daily basis for distortion or cracks.
15. **ALWAYS** store outriggers before road travel.
16. **WARNING! NEVER OPERATE THE CRANE NEAR ELECTRICAL POWER LINES!** Death or serious injury will result from boom, line, or load contacting electric lines. Do not use crane within 10 feet (3.05m) of electric power lines carrying up to 50,000 volts. One foot additional clearance is required for every additional 30,000 volts or less.
17. **WARNING! NEVER EXCEED** load chart capacities (centerline of rotation to hoist hook).
18. **WARNING! NEVER** un-reel last 5 wraps of cable from drum!
19. **WARNING! NEVER** wrap cable around load!
20. **WARNING! NEVER** attempt to lift or drag a load from the side! The boom can fail far below its rated capacity.
21. **WARNING! NEVER** weld, modify, or use unauthorized components on any Auto Crane unit! This will void any warranty or liability. Also failure of the crane may result.
22. **WARNING! NEVER** place a chain link on the tip of the hook and try to lift a load!
23. **WARNING! NEVER** use a sling bar or anything larger than the hook throat that could prevent the hook latch from closing, thus negating the safety feature!
24. **WARNING!** In using a hook with latch, **ALWAYS** insure that the hook throat is closed before lifting a load! Proper attention and common sense applied to the use of the hoist hook and various slings will prevent possible damage to material being hoisted and may prevent injury to personnel.
25. **WARNING! NEVER** hold any pendant Select Switch on that will cause unsafe operating conditions!

WARNING!

Auto Crane Company remote controlled, stiff boom cranes are not designed or intended to be used for any applications involving the lifting or moving of personnel.

--- IMPORTANT --- OPERATION OF UNIT

26. Make sure this manual has been thoroughly read by all crane operating personnel and supervisors.
27. A routine inspection of the crane should be mandatory before each operating day. Any defects should be corrected immediately.
28. At a job site the vehicle should be positioned so that the crane can adequately reach the load within the rated capacity (centerline of rotation to hoist hook).
29. Keep the vehicle as level as possible during operation.
30. For electric cranes, **engage emergency brake** and leave ignition on with transmission in neutral (or in park for automatic transmissions). Activate any crane power switches. For Auto Crane units requiring battery and hydraulic operation, **engage emergency brake**, place gear selector in neutral, press clutch, activate PTO, release clutch and after hydraulic fluid is warm, set throttle control to proper engine speed.
31. Always use outriggers from the truck to the ground. Be sure these are firm and adequately positioned. When rotating, **keep load as low to the ground as possible**.
32. Remove pendant control from cab or storage area. On smaller units, plug pendant into receptacle on crane. On larger units, remove pendant control from guard and unwrap cable from boom. Do not operate crane until cable is unwound completely. On all cranes, detach hook from dead man. Crane is now ready for operation.
33. Always boom up before rotating so the boom will clear the required boom support.
34. When extending the boom, always maintain clearance between the boom crown and the traveling block or hoist hook.
35. Always observe safe and practical operation to avoid possible accidents. Refer to Safety Tips and Precautions.
36. After completing lifting operations, return the boom to stowed position on the boom support. Avoid unneeded pressure on the boom support.
37. Store pendant control on proper location (in cab or on crane).
38. Return outriggers to stowed position. Make sure they are pinned in place or jacklegs are returned to compartment.
39. Check work area for any tools or equipment not stored.
40. Release throttle control, depress clutch and disengage PTO. Deactivate any crane power switches.
41. Report any unusual occurrence during crane operation that may indicate required maintenance or repair.
42. **NEVER** use two cranes to support a load too large for either crane.
43. Spray all electrical equipment with special corrosion resistant coating. This eliminates rust or corrosion due to melting and freezing action of condensation.

OPERATION OF OUTRIGGERS

For hydraulic outriggers:

1. Shift crane/outrigger control valve to "outrigger" position.
2. While operating the outrigger control valves (located on the outrigger cylinders) simultaneously operate the boom-up control switch. This will allow the hydraulic system to build pressure.
3. After outriggers are positioned, return crane/outrigger selector to "crane" position.
4. Crane is now ready to operate.

For manual outriggers:

1. Pull lock pins to release jack leg or drop down outrigger and move to outermost lock position.
2. Make sure lock pins are reinstalled properly.
3. Lower outrigger pad to firm ground and adjust foot to take out slack.
4. Crane is now ready to operate.

QUALIFICATIONS FOR AND CONDUCT OF OPERATORS AND OPERATING PRACTICES

OPERATORS

- 1 Crane operation shall be limited to personnel with the following minimum qualifications:**
 - A. designated persons
 - B. trainees under the direct supervision of a designated person
 - C. maintenance and test personnel (when it is necessary in the performance of their duties)
 - D. inspectors (crane).
- 2 No one other than the personnel specified above shall enter the operating area of a crane with the exception of persons such as oilers, supervisors, and those specified persons authorized by supervisors whose duties require them to do so and then only in the performance of their duties and with the knowledge of the operator or other persons.**

QUALIFICATIONS FOR OPERATORS

- 3 Operators shall be required by the employer to pass a practical operating examination. Qualifications shall be limited to the specific type of equipment for which examined.**
- 4 Operators and operator trainees shall meet the following physical qualifications:**
 - A. Vision of at least 20/30 Snellen in one eye and 20/50 in the other, with or without corrective lenses.
 - B. Ability to distinguish colors, regardless of position, if colors differentiation is required for operation.
 - C. Adequate hearing with or without hearing aid for the specific operation.
- 5 Evidence of physical defects or emotional instability which render a hazard to operator or others, which in the opinion of the examiner could interfere with the operator's performance may be sufficient cause for disqualification. In such cases, specialized clinical or medical judgment and tests may be required.**
- 6 Evidence that the operator is subject to seizures or loss of physical control shall be sufficient reason for disqualification. Specialized medical tests may be required to determine these conditions.**

- 7 Operators and operator trainees should have normal depth perception, coordination, and no tendencies to dizziness or similar undesirable characteristics.**
- 8 In addition to the above listed requirements, the operator shall:**
 - A. Demonstrate the ability to comprehend and interpret all labels, operator's manuals, safety codes and other information pertinent to correct crane operations.
 - B. Possess knowledge of emergency procedures and implementation of same.
 - C. Demonstrate to the employer the ability to operate the specific type of equipment.
 - D. Be familiar with the applicable safety regulations.
 - E. Understand responsibility for maintenance requirements of crane.
 - F. Be thoroughly familiar with the crane and its control functions.
 - G. Understand the operating procedures as outlined by the manufacturer.

CONDUCT OF OPERATORS

- 9 The operator shall not engage in any practice which will divert his attention while actually operating the crane.**
- 10 Each operator shall be responsible for those operations under the operator's direct control. Whenever there is any doubt as to safety, the operator shall consult with the supervisor before handling the loads.**
- 11 The operator should not leave a suspended load unattended unless specific precautions have been instituted and are in place.**
- 12 If there is a warning sign on the switch or engine starting controls, the operator shall not close the switch or start the engine until the warning sign has been removed by the appointed person.**
- 13 Before closing the switch or starting the engine, the operator shall see that all controls are in the "OFF" or neutral position and all personnel are in the clear.**
- 14 If power fails during operation, the operator shall:**
 - A. move power controls to the "OFF" or neutral position.

QUALIFICATIONS FOR AND CONDUCT OF OPERATORS AND OPERATING PRACTICES

B. land the suspended load and boom, if practical.

15 The operator shall be familiar with the equipment and its proper care. If adjustments or repairs are necessary, the operator shall report the same promptly to the appointed person, and shall also notify the next operator.

16 All controls shall be tested by the operator at the start of each shift. If any controls do not operate properly, they shall be adjusted or repaired before operations are begun.

17 Stabilizers shall be visible to the operator while extending or setting unless operator is assisted by a signal person.

OPERATING PRACTICES

HANDLING THE LOAD

18 Size of load

- A. No crane shall be loaded beyond the rated load except for test purposes.
- B. The load to be lifted is to be within the rated load of the crane and its existing configuration.
- C. When loads which are not accurately known are to be lifted, the person responsible for the job shall ascertain that the weight of the load does not exceed the crane rated load at the radius at which the load is to be lifted.

19 Attaching the load

- A. The load shall be attached to the hook by means of slings or other devices of sufficient capacity.
- B. Hoist rope shall not be wrapped around the load.

20 Moving the load

- A. The operator shall determine that:
- B. The crane is level and, where necessary, the vehicle/carrier is blocked properly.
- C. The load is well secured and balanced in the sling or lifting device before it is lifted more than a few inches.
- D. Means are provided to hold the vehicle stationary while operating the crane.
- E. Before starting to lift, the hook shall be brought over the load in such a manner as to minimize swinging.

F. During lifting care shall be taken that:

- 1. **there is no sudden acceleration or deceleration of the moving load.**
- 2. **load, boom or other parts of the crane do not contact any obstruction.**

G. Cranes shall not be used for dragging loads sideways.

H. This standard recognizes that articulating boom cranes are designed and intended for handling materials. They do not meet personnel lift or elevator requirements. Therefore, no lifting, lowering, swinging or traveling shall be done while a person is on the hook or load. Hook attached suspended work platforms (baskets) shall not be used with cranes covered by this standard. Work platforms attached to the boom must be approved by crane manufacturer.

I. The operator should avoid carrying loads over people.

J. When the crane is so equipped, the stabilizers shall be fully extended and set. Blocking under stabilizers shall meet the requirements as follows:

- 1. **strong enough to prevent crushing.**
- 2. **of such thickness, width and length as to completely support the stabilizer pad.**

K. Firm footing under all tires, or individual stabilizer pads should be level. Where such a footing is not otherwise supplied, it should be provided by timbers, cribbing, or other structural members to distribute the load so as to not exceed allowable bearing capacity or the underlying material.

L. In transit, the boom shall be carried in stowed position.

M. When rotating the crane, sudden starts and stops shall be avoided. rotational speed shall be such that the load does not swing out beyond the radius at which it can be controlled.

N. The crane shall not be transported with a load on the hook unless recommended by the manufacturer.

O. No person should be permitted to stand or pass under a suspended load.

21 Stowing procedure. Follow the manufacturer's procedure and sequence when stowing and un-stowing the crane.

QUALIFICATIONS FOR AND CONDUCT OF OPERATORS AND OPERATING PRACTICES

MISCELLANEOUS

OPERATING NEAR ELECTRICAL POWER LINES

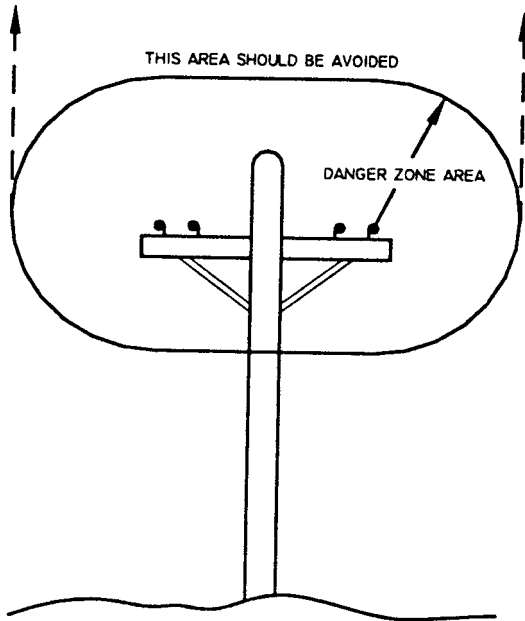

22 Cranes shall be operated so that no part of the crane or load enters into the danger zone shown above.

EXCEPTIONS

- A. The danger zone may be entered after confirmation by an appointed person that the electrical distribution and transmission lines have been de-energized and visibly grounded at the point of work; or
- B. The danger zone may be entered if insulating barriers (not a part of nor an attachment to the crane) have been erected to prevent physical contact with the lines.

23 For lines rated 50 kV or below, minimum clearance between the lines and any part of the crane or load (including handling appendages) shall be 10 ft. (3m). For higher voltages, see Table 1.

24 Caution shall be exercised when working near overhead lines, because they can move horizontally or vertically due to wind, moving the danger zone to new positions.

25 In transit with no load and boom lowered the clearance shall be specified in Table 1.

26 A qualified signalperson shall be assigned to observe the clearance and give warning before approaching the above limits.

- A. Any overhead wire shall be considered to be an energized line unless and until the person owning such line or the electrical utility authorities verify that it is not an energized line.
- B. Exceptions to this procedure, if approved by the administrative or regulatory authority if the alternate procedure provides equivalent protection and set forth in writing.
- C. Durable signs shall be installed at the operator's station and on the outside of the crane, warning that electrocution or serious bodily injury may occur unless a minimum clearance of 10 ft. (3.0m) between the crane or the load being handled and energized power lines. Greater clearances are required because of higher voltage as stated above. These signs shall be revised but not removed when local jurisdiction requires greater clearances.

TABLE 1

normal voltage, kV (phase to phase)		minimum required clearance	
		ft	(m)
<u>when operating near high voltage power lines</u>			
over	to 50	10	(3.05)
over	50 to 200	15	(4.6)
over	200 to 350	20	(6.1)
over	350 to 500	25	(7.62)
over	500 to 750	35	(10.67)
over	750 to 1000	45	(13.72)
<u>while in transit with no load and boom lowered</u>			
over	to 0.75	4	(1.22)
over	0.75 to 50	6	(1.83)
over	50 to 345	10	(3.83)
over	345 to 750	16	(4.87)
over	750 to 1000	20	(6.1)

INSPECTION, TESTING AND MAINTENANCE

GENERAL

INSPECTION CLASSIFICATION

27 Initial inspection. Prior to initial use, all new, altered, modified or extensively repaired cranes shall be inspected by a designated person to insure compliance with provisions of this standard.

28 Regular inspection. Inspection procedure for cranes in regular service is divided into two general classifications based upon the intervals at which inspection should be performed. The intervals in turn are dependent upon the nature of the components of the crane and the degree of their exposure to wear, deterioration, or malfunction. The two general classifications are herein designated as "frequent" and "periodic" with respective intervals between inspections as defined below.

- A. frequent inspection - daily to monthly intervals
- B. periodic inspection - one to twelve intervals, or as specifically recommended by the manufacturer

FREQUENT INSPECTION

29 Inspection shall be performed by designated personnel.

- A. control mechanisms for maladjustment interfering with proper operation - daily, when used
- B. control mechanisms for excessive wear of components and contamination by lubricants or other foreign matter
- C. safety devices for malfunction
- D. all hydraulic hoses, particularly those which flex in normal operation of crane functions, should be visually inspected once every working day, when used
- E. hooks and latches for deformation, chemical damage, cracks, and wear. Refer to ANSI/ASME B30.10
- F. rope reeving for compliance with crane manufacturer's specifications, if optional winch is used

G. electrical apparatus for malfunctioning, signs of excessive deterioration, dirt and moisture accumulation

H. hydraulic system for proper oil level and leaks daily

I. tires for recommended inflation pressure, cuts and loose wheel nuts

J. connecting pins and locking device for wear and damage

PERIODIC INSPECTION

30 Deformed, cracked or corroded members in the crane structure and carrier.

31 Loose bolts, particularly mounting bolts.

32 Cracked or worn sheaves and drums.

33 Worn, cracked, or distorted parts such as pins, bearings, shafts, gears, rollers and devices.

34 Excessive wear on brake and clutch system parts and lining.

35 Crane hooks inspected for cracks.

36 Travel steering, braking, and locking devices, for malfunction.

37 Excessively worn or damaged tires.

38 Hydraulic and pneumatic hose, fittings, and tubing inspection.

A. evidence of leakage at the surface of the flexible hose or its junction with metal and coupling

B. blistering, or abnormal deformation to the outer covering of the hydraulic or pneumatic hose

C. leakage at threaded or clamped joints that cannot be eliminated by normal tightening or recommended procedures

D. evidence or excessive abrasion or scrubbing on the outer surface of a hose, rigid tube, or fitting. Means shall be taken to eliminate the interference of

INSPECTION, TESTING AND MAINTENANCE

GENERAL

elements in contact or otherwise protect the components

necessary to determine origin of the problem before corrective action can be taken.

39 Hydraulic and pneumatic pumps and motors inspection.

- A. loose bolts or fasteners
- B. leaks at joints between sections
- C. shaft seal leaks
- D. unusual noises or vibrations
- E. loss of operating speed
- F. excessive heating of the fluid
- G. loss of pressure

40 Hydraulic and pneumatic valves inspection.

- A. cracks in valve housing
- B. improper return of spool to neutral position
- C. leaks at spools or joints
- D. sticking spools
- E. failure of relief valves to attain or maintain correct pressure setting
- F. relief valve pressure shall be checked as specified by the manufacturers

41 Hydraulic and pneumatic cylinders inspection.

- A. drifting caused by fluid leaking across piston
- B. rod seals leaking
- C. leaks at welding joints
- D. scored, nicked, or dented cylinder rods
- E. damaged case (barrel)
- F. loose or deformed rod eyes or connecting joints

42 Hydraulic filters. Evidence of rubber particles on the filter elements may indicate hose, "O" ring, or other rubber component deterioration. Metal chips or pieces on the filter may denote failure in pumps, motors, or cylinders. Further checking will be

43 Labels are to be in place and legible.

CRANES NOT IN REGULAR USE

44 A crane which has been idle for a period of over one month or more, but not less than six months, shall be given an inspection conforming with the initial-regular- frequent inspections.

45 A crane which has been idle for a period of over six months shall be given a complete inspection conforming with the initial-regular-frequent inspection requirements.

INSPECTION RECORDS

46 Dated records for periodic inspection should be made on critical items such as brakes, crane hooks, rope, hydraulic and pneumatic cylinders, and hydraulic and pneumatic relief pressure valves. Records should be kept available to an appointed person.

OPERATIONAL TESTS

47 Prior to initial use, all new, altered, modified, or extensively repaired cranes shall be tested for compliance with the operational requirements of this section, including functions such as the following:

- A. load lifting and lowering mechanisms
- B. boom lifting and lowering mechanisms
- C. boom extension and retraction mechanisms
- D. swing mechanisms
- E. safety devices
- F. operating controls comply with appropriate function labels

Operational crane test results shall be made available to an appointed person.

RATED TEST LOAD

Prior to initial use, altered, modified, or extensively repaired cranes shall be load

INSPECTION, TESTING AND MAINTENANCE

GENERAL

tested by or under the direction of an appointed person.

48 Test loads shall not exceed 110% of the manufacturer's load ratings.

49 Written reports shall be maintained showing test procedures and confirming the adequacy of repairs.

MAINTENANCE

PREVENTIVE MAINTENANCE

50 Before adjustment and repairs are started on a crane, the following precautions shall be taken as applicable:

- A. crane placed where it will cause the least interference with other equipment or operations
- B. all controls at the "off" position
- C. starting means rendered inoperative
- D. boom lowered to the ground if possible or otherwise secured against dropping
- E. relieve hydraulic oil pressure from all hydraulic circuits before loosening or removing hydraulic components

51 Warning or "OUT OF ORDER" signs shall be placed on the crane controls.

52 After adjustments and repairs have been made, the crane shall not be returned to service until all guards have been reinstalled, trapped air removed from hydraulic system (if required), safety devices reactivated, and maintenance equipment removed.

ADJUSTMENTS AND REPAIRS

53 Any hazardous conditions disclosed by the inspection requirements shall be corrected before operation of crane is resumed, Adjustments and repairs shall be done only by designated personnel.

54 Adjustments shall be maintained to assure correct functioning of components, The following are examples:

- A. functional operating mechanism
- B. safety devices
- C. control systems

55 Repairs or replacements shall be provided as needed for operation.

The following are examples:

- A. critical parts of functional operating mechanisms which are cracked, broken, corroded, bent, or excessively worn
- B. critical parts of the crane structure which are cracked, bent, broken, or excessively corroded
- C. crane hooks showing cracks, damage, or corrosion shall be taken out of service. Repairs by welding are not recommended

56 Instructions shall be provided by the manufacturer for the removal of air from hydraulic circuits.

LUBRICATION

All moving parts of the crane, for which lubrication is specified, should be regularly lubricated per the manufacturer's recommendations and procedures.

ROPE INSPECTION

57 Frequent Inspection

- A. All running ropes in service should be visually inspected once each working day. A visual inspection shall consist of observation of all rope which can be in use during the days operations. These visual observations should be considered with discovering gross damage such as listed below, which may be an immediate hazard.

- 1. distortion of the rope such as kinking, crushing, un-stranding, birdcaging, main strand displacement, or core protrusion. Loss of rope diameter in a short length or unevenness of outer strands should be replaced**

- 2. general corrosion**

INSPECTION, TESTING AND MAINTENANCE

GENERAL

3. broken or cut strands;
4. number, distribution and type of visible broken wires. When such damage is discovered, the rope shall either be removed from service or given as inspection.

B. Care shall be taken when inspecting sections of rapid deterioration such as flange points, crossover points, and repetitive pickup points on drums.

58 Periodic inspection

A. The inspection frequency shall be determined by a qualified person and shall be based on such factors as:

1. expected rope life as determined by experience on the particular installation or similar installations
2. severity of environment
3. percentage of capacity lifts
4. frequency rates of operation
5. exposure to shock loads

Inspection need not be at equal calendar intervals and should be more frequent as the rope approaches the end of its service life. This inspection shall be made at least annually.

B. Periodic inspection shall be performed by a designated person. This inspection shall cover the entire length of the rope. Only the surface wires need be inspected. No attempt should be made to open the rope. Any deterioration results in appreciable loss of original strength, such as described below, shall be noted and determination made as to whether use of the rope would constitute a hazard: points listed above reduction of rope diameter below nominal diameter due to loss of core support, internal or external corrosion, or wear of outside wires; severely corroded, cracked, bent, worn or improperly applied connections;

C. Care shall be taken when inspecting sections subject to rapid deterioration such as the following:

1. sections in contact with saddles, equalizer sheaves, or other sheaves where rope travel is limited
2. sections of the rope at or near terminal ends where corroded or broken wires may protrude

ROPE REPLACEMENT

59 No precise rules can be given for determination of the exact time for replacement of rope, since many variable factors are involved.

Continued use in this respect depends upon good judgement by a designated person in evaluating remaining strength in a used rope after allowance for deterioration disclosed by inspection. Continued rope operation depends upon this remaining strength.

60 Conditions such as the following shall be reason for questioning continued use of the rope or increasing the frequency of inspection:

- A. in running ropes, six randomly distributed broken wires in one lay or three broken wires in one strand in one lay
- B. one outer wire broken at the contact point with the core of the rope structure and protrudes or loops out of the rope structure. Additional inspection of this section is required
- C. wear of one third of the original diameter of the outside individual wire
- D. kinking, crushing, birdcaging, or any other damage resulting in distortion of the rope structure
- E. evidence of any heat damage from any cause
- F. reduction from nominal diameter of more than 1/64 in. (0.4mm) for diameters up to and including 5/16 in. (8 mm), 1/32 in. (0.8 mm) for diameter 3/8 in. (9.5 mm) to and including 1/2 in. (13 mm), 3/64 in. (1.2 mm) for diameter 9/16 in. (14.5 mm) to and including 3/4 in. (19 mm). 1/16 in. (1.6 mm) for diameter 7/8 in. (22 mm) to and including 11/8 in. (29 mm), 3/32 in. (2.4 mm) for diameters 11/4 in. (32 mm) to and including 11/2 in. (38 mm)

INSPECTION, TESTING AND MAINTENANCE

GENERAL

G. In standing ropes, more than two broken wires in one lay in sections beyond end connections or more than one broken wire at an end connection.

H. Replacement rope shall have a strength rating at least as great as the original rope furnished or recommended by the crane manufacturer. Any deviation from the original size, grade, or construction shall be specified by a rope manufacturer, or a qualified person.

61 Rope not in regular use: all rope which has been idle for a period of a month or more due to shutdown or storage of a crane on which it is installed, shall be given an inspection in accordance with above information before it is placed in service. This inspection shall be for all types of deterioration and shall be performed by a qualified person.

62 Inspection records

- A. frequent inspection- no records required
- B. periodic inspections- in order to establish data as a basis for judging the proper time for replacement, a dated report condition at each periodic inspection should be kept on file. This report shall cover points of deterioration listed above.

ROPE MAINTENANCE

63 Rope should be stored to prevent damage or deterioration.

64 Unreeling or uncoiling of rope shall be done as recommended by the rope manufacturer and with care to avoid kinking or inducing twist.

65 Before cutting a rope, seizing shall be placed on each side of the place where the rope is to be cut to prevent unlaying of the strands. On pre-formed rope, one seizing on each side of the cut is required. On non-preformed ropes of 7/8 in. (22 mm) diameter or smaller, two seizings on each side of the cut are required, and for non-preformed rope 1 in. (25 mm) diameter or larger, three seizings on each side of the cut are required.

66 During installation care should be exercised to avoid dragging of the rope in the dirt or around objects which will scrape, nick crush or induce sharp bends in it.

67 Rope should be maintained in a well-lubricated condition. It is important that lubricant applied as a part of a maintenance program shall be compatible with the original lubricant and to this end the rope manufacturer should be consulted. Lubricant applied shall be the type which does not hinder visual inspection. Those sections of rope which are located over sheaves or otherwise hidden during inspection and maintenance procedures require special attention when lubricating rope. The object of rope lubrication is to reduce internal friction and to prevent corrosion.

68 When an operating rope shows greater wear or well defined localized areas than on the remainder of the rope, rope life can be extended in cases where a section at the worn end, and thus shifting the wear to different areas of the rope.

LIFE OF WIRE LINE

So many variable factors can cause the deterioration of wire line cable that it is not possible to determine a definite life expectancy. Some of these factors are:

- **Load being handled.**
- **Corrosive conditions.**
- **Maintenance of the unit:**
 - Keep the sheaves turning freely.
 - Maintain tension on cable to insure proper spooling.
 - Avoid kinks in cable.
 - Avoid abrasive action and contact with sharp corner.
- **Frequency of use.**

Auto Crane units, up to 2,400 pound ratings use 3/16 inch diameter galvanized pre-formed 7 x 19 aircraft cable. This cable has a working strength, when new, of 4,200 pounds. It is recommended when 1,200 pound loads are exceeded to use a two part line with a traveling block. This will ensure a 3.5 to 1 safety factor when the cable is new.

Keeping the above factor of safety in mind and knowing the kind of loads that will be handled, the user can determine by inspection of the cable as to when it should be replaced.

Items to look for while inspecting the cables are:

- Broken strands.
- Kinks and flattened sections.
- Corrosion and abrasion.

WIRE LINE LUBRICATION

Lubrication of the wire line serves two important purposes:

- Prevent corrosion.
- Reduce wear due to flexing and abrasion caused by contact with the sheaves, rollers, and cable on the drum.

Preparation

Remove rust and foreign matter with a wire brush and wipe clean. Be sure cable is dry.

Application

Method 1: Dip a brush into a light weight motor oil and apply. In some cases, dip a rag or a piece of sheepskin into the lubricant and swab the lubricant on to the rope.

Method 2: Apply a heavier lubricant such as a grease gun lubricant with hands while wearing leather gloves. (Leather gloves give greater protection and less penetration of the grease than canvas gloves.)

MAINTENANCE OF BATTERIES

Maintenance of Auto Crane unit batteries differs very little from the generally prescribed maintenance of any lead acid battery. All batteries must be kept *properly charged, properly filled with water, and relatively clean.*

Keep Properly Charged

Many things affect the proper charge to a battery, such as:

- 1 Regulator settings
- 2 Proper tightness of belts on the alternator or generator
- 3 Good, clean connections of all cables and wires at the following places:
 - A. Battery
 - B. Regulator
 - C. Starting motor
 - D. Alternator or generator
 - E. Ground connections (most important)

It is of extreme importance to keep the battery as fully charged as possible without overcharging, especially when vehicles are left outside for extended periods in extremely cold climates. A battery *can* freeze. Freezing points for various specific gravities of acid are as follows:

Specific Gravity (Corrected to 80°F)	Freezing Temp. Degrees F.
1.280	-90°F
1.250	-62°F
1.200	-16°F
1.150	5°F
1.100	19°F

As shown, a half-charged battery (about 1.200 specific gravity) cannot stand for any length of time at 20°F or it will freeze.

The *main reason* for keeping the battery as fully charged as possible without over-charging is to ensure that power is available even though the vehicle has been standing for some time.

Keep Properly Filled with Water

The battery should *always* be properly filled with water. If the electrolyte level is allowed to fall below the top of the plates, the results become threefold:

- 1 The exposed portion of the plate will become sulfated.
- 2 The portion of the plate exposed is not usable.
- 3 That portion of the acid remaining becomes more concentrated and may cause more rapid deterioration of the remaining parts of the battery.

Keep A Relatively Clean Battery

The battery should be kept clean. Batteries filled with acid and which are not in use self-discharge to a limited degree because of the nature of the materials within the battery. If dirt is allowed to collect on the top of the battery (and this dirt absorbs moisture) and electrical path can be set up between the various terminals of the battery and the ground. Once such a path has been established, the self-discharge of the battery is accelerated. This also accelerates corrosion of the battery cables at the terminals.

Periodic Maintenance is Needed

A definite program of periodic maintenance of all batteries should be conducted on a regular basis. Periodic maintenance includes:

- 1 Checking belts for tightness on the charging equipment
- 2 Checking battery electrolyte levels
- 3 Checking cables for good connections
- 4 Cleaning where corrosion is apparent

When corrosion is cleaned off, the cable terminals and battery terminals should be coated with a light coating of petroleum jelly before they are replaced. When terminals are cleaned, the top of the battery should be cleaned with a mild solution of soda water.

MAINTENANCE OF BATTERIES

Low Maintenance Batteries (Maintenance Free)

Low maintenance batteries should not be used on Auto Cranes or trucks equipped with Auto Cranes. The batteries are not designed for "deep" discharge.

Testing Your Battery

If the condition of the battery is in question, it should be removed from the vehicle, taken to the shop, and allowed to reach room temperature. It should then be recharged until specific gravity readings taken at one-half hour intervals. If the specific gravity readings are fairly uniform, the battery should be checked with a high rate tester. Use the tester in accordance with the manufacturer's instructions. The high rate tester is the best method to test a questionable battery.

If, after charging, it is noted that the specific gravity reading of one cell is 30 points less than any of the other cells, it may be assumed that the cell is bad and that the battery should be replaced. If all cells are uniform but not up to full charge, a low rate of charge

should be attempted for an extended time. This usually will recover a badly sulfated battery.

Replacing a Battery

If it is necessary to replace a battery, and a dry charge battery is used, the following procedure applies:

- 1 Fill the battery with electrolyte of the proper specific gravity.
- 2 Place the battery on charge according to the manufacturer's instructions.

It is essential that the second step above be followed to ensure that the battery going on the vehicle is fully charged.

It is also very important that the battery hold-downs be checked periodically to ensure that the batteries are properly positioned to avoid vibration problems, breakage of cables or terminals. Care must be taken to avoid cracking or breaking containers or covers by tightening hold-down fixtures excessively. They also must not be so loose that breakage results from a hold-down that is too loose.

SAFETY DECAL SECTION

PART NO.: 040517
DECAL: STAY CLEAR OF BOOM
FUNCTION: To inform the operator of the hazard of proximity or contact with the crane boom during operation.
QUANTITY: 2
PLACEMENT: Both sides of crown
(see page 1-7.3.0/1-7.4.0, Item 12)



FIG. SD-1.

PART NO.: 040518
DECAL: STAY CLEAR OF LOAD
FUNCTION: To inform the operator of the hazard of proximity or contact with the crane load during operation.
QUANTITY: 2
PLACEMENT: Both sides of crown plate
(see page 1-7.3.0/1-7.4.0, Item 13)



FIG. SD-2.

PART NO.: 040519
DECAL: SCISSORS POINT
FUNCTION: To inform the operator of possible danger at scissors point on crane.
QUANTITY: 1
PLACEMENT: Both sides of lift cylinder
(see page 1-7.3.0/1-7.4.0, Item 17)

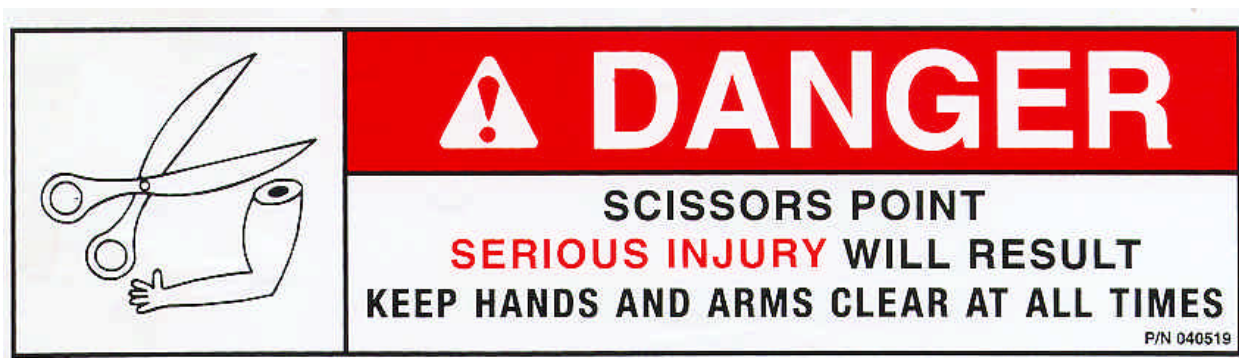

FIG. SD-3.

SAFETY DECAL SECTION

PART NO.: 040529 QUANTITY: 2
DECAL: ELECTROCUTION HAZARD PLACEMENT: Both sides of end of lower boom
FUNCTION: To inform the operator of the hazard involved with contacting electrical power lines with crane boom. (see page 1-7.3.0/1-7.4.0, Item 11)

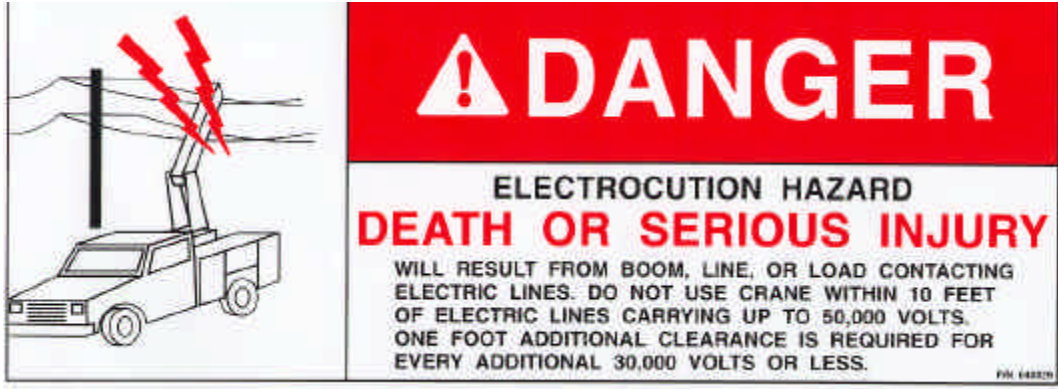

FIG. SD-4.

PART NO.: 040580
DECAL: OPERATOR TRAINING
FUNCTION: To inform the operator of the need to receive proper training before using the crane.
QUANTITY: 1
PLACEMENT: Left Sideplate (see page 1-7.3.0/1-7.4.0, Item 4)

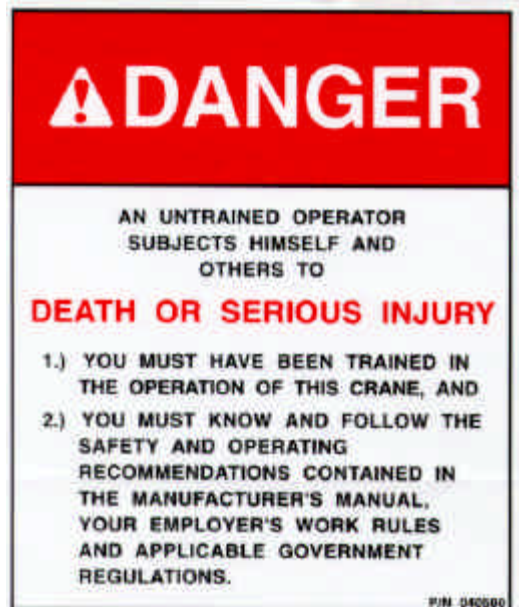

FIG. SD-5.

SAFETY DECAL SECTION

PART NO.: 040579
DECAL: OPERATION INSTRUCTIONS
FUNCTION: To inform the operator of the proper procedure to follow for safe operation of the crane.
QUANTITY: 1
PLACEMENT: Left Sideplate
(see page 1-7.3.0/1-7.4.0, Item 1)

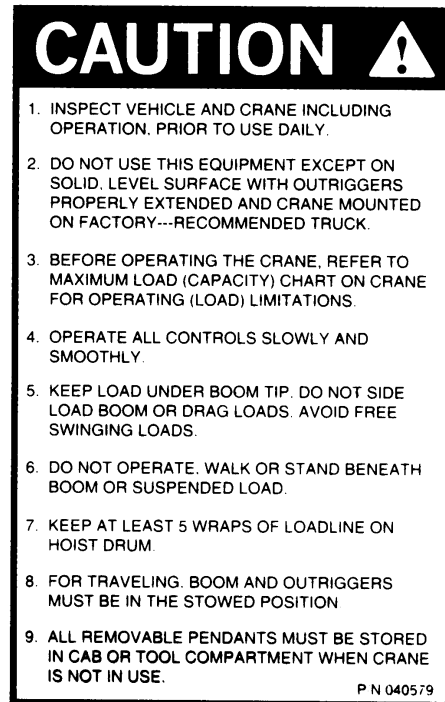

FIG. SD-6.

PART NO.: 040587
DECAL: LOAD SENSOR
FUNCTION: To inform the operator that the load sensor is pre-set and that tampering with the sensor may cause potentially hazardous situation.
QUANTITY: 1
PLACEMENT: On the lift cylinder near the load sensor
(see page 1-7.3.0/1-7.4.0, Item 15)



FIG. SD-7.

PART NO.: 040632
DECAL: TAMPERING WITH OVERLOAD DEVICE
FUNCTION: To inform the operator that tampering with the overload device may cause a unit failure or possible personnel injury.
QUANTITY: 1
PLACEMENT: Right side of lift cylinder
(see page 1-7.3.0/1-7.4.0, Item 5)



FIG. SD-8.

DECAL DRAWING

4004H 10-16-20 BOOM

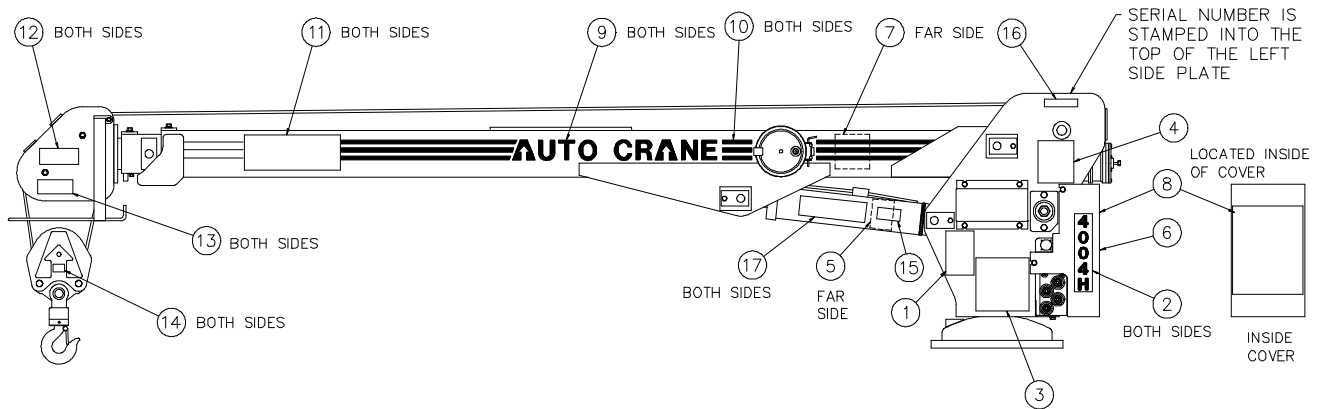

ITEM	QTY	P/N	DESCRIPTION
1	1	040579	CAUTION "INSPECT VEHICLE..." DECAL
2	2	404122	4004H DECAL
3	1	404121	4004H LOAD CHART (10-16-20) DECAL
4	1	040580	DANGER "AN UNTRAINED OPERATOR..." DECAL
5	1	040632	WARNING "TAMPERING WITH OVERLOAD..." DECAL
6	1	360034	LOGO DECAL
7	1	320318	ANGLE INDICATOR DECAL
8	1	404088	ELECTRIC SCHEMATIC DECAL
9	2	040624	AUTO CRANE DECAL
10	11 FT	040620	STRIPING DECAL
11	2	040529	DANGER "ELECTROCUTION HAZARD" DECAL
12	2	040517	DANGER "STAY CLEAR OF BOOM" DECAL
13	2	040518	DANGER "STAY CLEAR OF LOAD" DECAL
14	2	360480-100	BLOCK WEIGHT & MAX. LOAD DECAL
15	1	040587	WARNING "LOAD SENSOR PRESET" DECAL
16	1	330622	SERIAL NUMBER DECAL
17	2	040519	DANGER "SCISSORS POINT" DECAL

DECAL DRAWING

4004H 10-16 BOOM

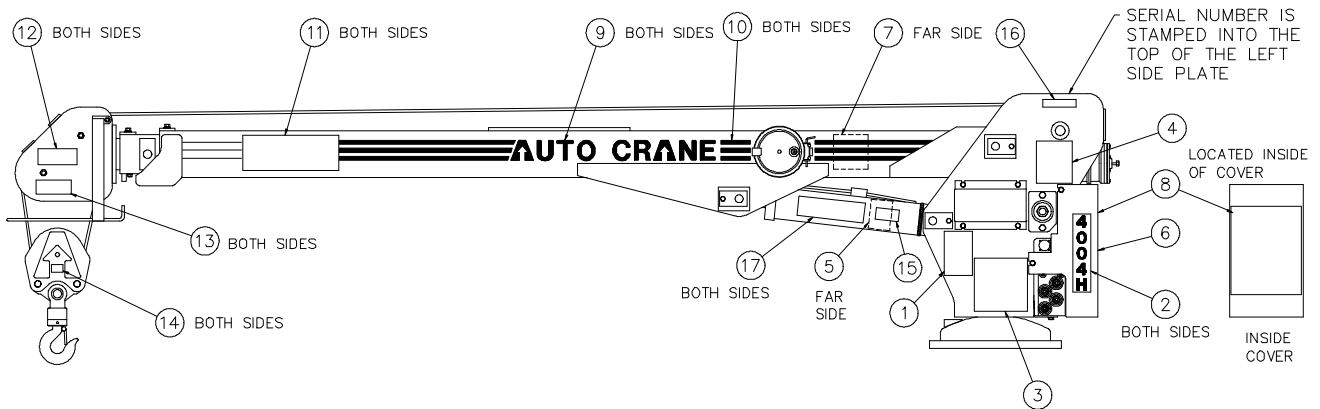

ITEM	QTY	P/N	DESCRIPTION
1	1	040579	CAUTION "INSPECT VEHICLE..." DECAL
2	2	404122	4004H DECAL
3	1	404120	4004H LOAD CHART (10-16) DECAL
4	1	040580	DANGER "AN UNTRAINED OPERATOR..." DECAL
5	1	040632	WARNING "TAMPERING WITH OVERLOAD..." DECAL
6	1	360034	LOGO DECAL
7	1	320318	ANGLE INDICATOR DECAL
8	1	404088	ELECTRIC SCHEMATIC DECAL
9	2	040624	AUTO CRANE DECAL
10	11 FT	040620	STRIPING DECAL
11	2	040529	DANGER "ELECTROCUTION HAZARD" DECAL
12	2	040517	DANGER "STAY CLEAR OF BOOM" DECAL
13	2	040518	DANGER "STAY CLEAR OF LOAD" DECAL
14	2	360480-100	BLOCK WEIGHT & MAX. LOAD DECAL
15	1	040587	WARNING "LOAD SENSOR PRESET" DECAL
16	1	330622	SERIAL NUMBER DECAL
17	2	040519	DANGER "SCISSORS POINT" DECAL

LUBRICATION & MAINTENANCE SCHEDULE for 4004H

SERVICE PERFORMED	DAILY	WEEKLY	6 MOS	YEAR	NOTES
LOAD HOOK	X				INSPECT HOOK & LATCH FOR DEFORMATION, CRACKS, & CORROSION
CABLE DRUM	X				MAKE SURE CABLE IS WOUND EVENLY ON DRUM
HOIST CABLE	X				CHECK FOR FLATTENING, KINKS, & BROKEN STRANDS, SEE MANUAL
HYDRAULIC HOSES	X				VISUAL INSPECTION
HYDRAULIC FLUID	X				CHECK FLUID LEVEL
MOUNTING BOLTS		X			CHECK/TORQUE TO 440 FT-LBS AS REQ.
ROTATION WORM GEAR		X			LUBE WITH MOBILTAC LL, OR LUBRIPLATE P/N 15263, OR EQUIVALENT
SHEAVE BEARINGS		X			SEALED BEARING, REPLACE IF ROUGH OR LOOSE
ALL OTHER BOLTS		X			CHECK-TIGHTEN AS REQUIRED
BOOM PIVOTS		X			GREASE WITH MOBILPLEX EP-2 OR EQUIV. @ ZERKS
BOOM CYLINDER		X			CHECK AROUND CYLINDER ROD FOR EXCESS FLUID LEAKAGE
BOOM CYLINDER PINS		X			GREASE WITH MOBILPLEX EP-2 OR EQUIV. @ ZERKS
EXTENSION DETENT PIN		X			LUBE DETENT SPRING & BALL w/ WD-40
HOIST GEARBOX			X		WORM GEAR-EP GEAR LUBE SAE 80-90, SPUR GEAR SAE 30 OIL
HYDRAULIC FLUID				X	DRAIN, FLUSH, & REFILL WITH SUN 2105 HYD. OIL, SAE 5W-20
BOOM SLIDE PADS	PADS GREASED WHEN REPLACED				
CAUTION	{ Routine maintenance insures trouble-free operation and protects your investment. All warranties are void if maintenance is neglected.				

NOTES:

1. Use only authorized parts. Any damage or malfunction caused by the use of unauthorized parts is not covered by Warranty or Product Liability.
2. Once a bolt has been torqued to its rated capacity and then removed; the bolt should be replaced with a new one.
3. Auto Crane Company recommends that this crane be serviced per "Crane Inspection Log" P/N 999978. These logs should be filled in at the intervals noted and kept as a permanent record. Additional copies are available from your local distributor.

ASSEMBLY & INSTALLATION INSTRUCTIONS

4004H SERIES

NOTE: For mounting bolt hole pattern - see GENERAL DIMENSIONS.

CAUTION:
BOOM MUST BE PROPERLY SECURED
IN PLACE, ON A BOOM SUPPORT
BRACKET, WHEN CRANE IS NOT IN
USE. (TO PREVENT GEAR DAMAGE)

BOOM SUPPORT BRACKET
AUTO CRANE P/N 726175

NOTICE:

WE RECOMMEND REPLACING
ANY NO-MAINTENANCE TRUCK
BATTERY WITH A MAINTENANCE
TYPE TRUCK BATTERY

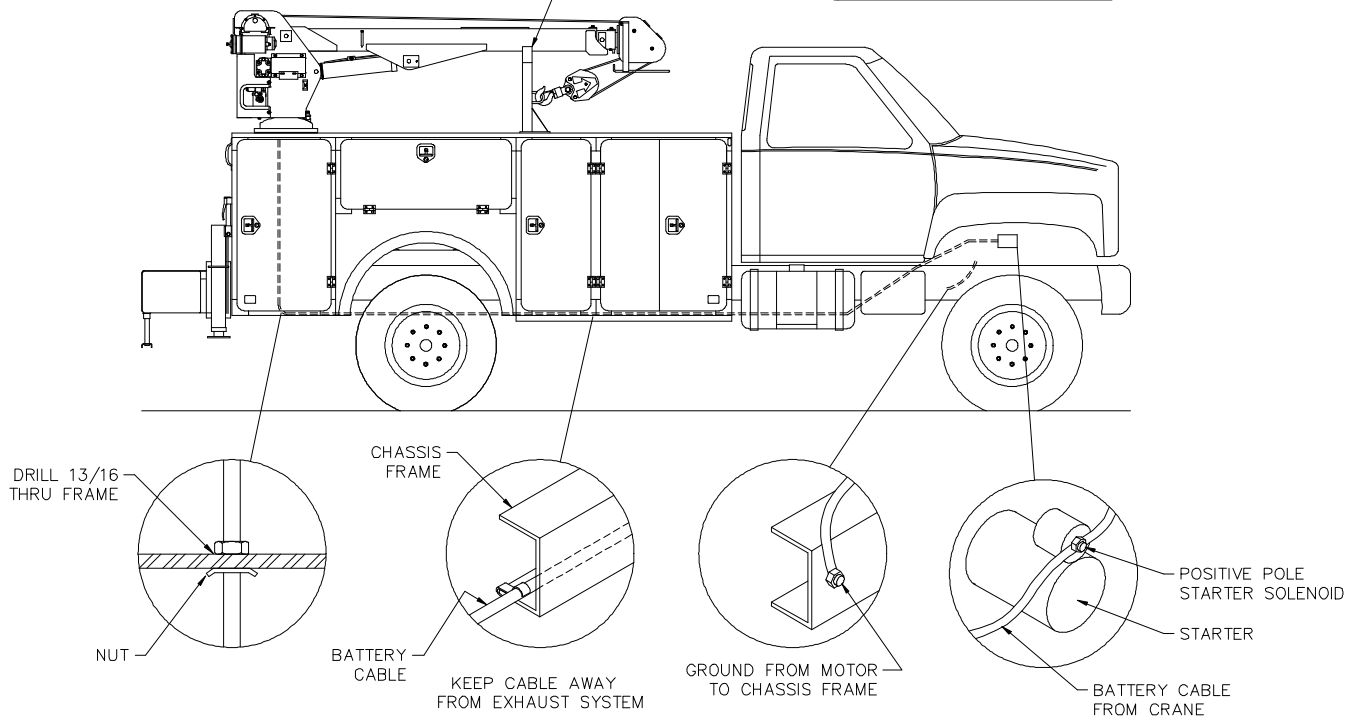

INSTALLATION - BATTERY CABLE

1. Drill 13/16" hole in floor. Install bushing, which is connected to cable, so it fits hole snug.
2. Run cable to positive battery terminal. Connect black cable to negative battery terminal or suitable chassis ground point. Locate cables so that they will be protected. Avoid sharp edges. Use the No. 083800 frame clips provided to hold cables securely in place.
3. If the battery is grounded to the engine it may be necessary to add an additional ground cable from the engine to the chassis frame to obtain maximum power at crane

BOOM SUPPORT

4004H SERIES

WARNING:

As with all Auto Crane power rotation units, the 4004H does require a boom support.

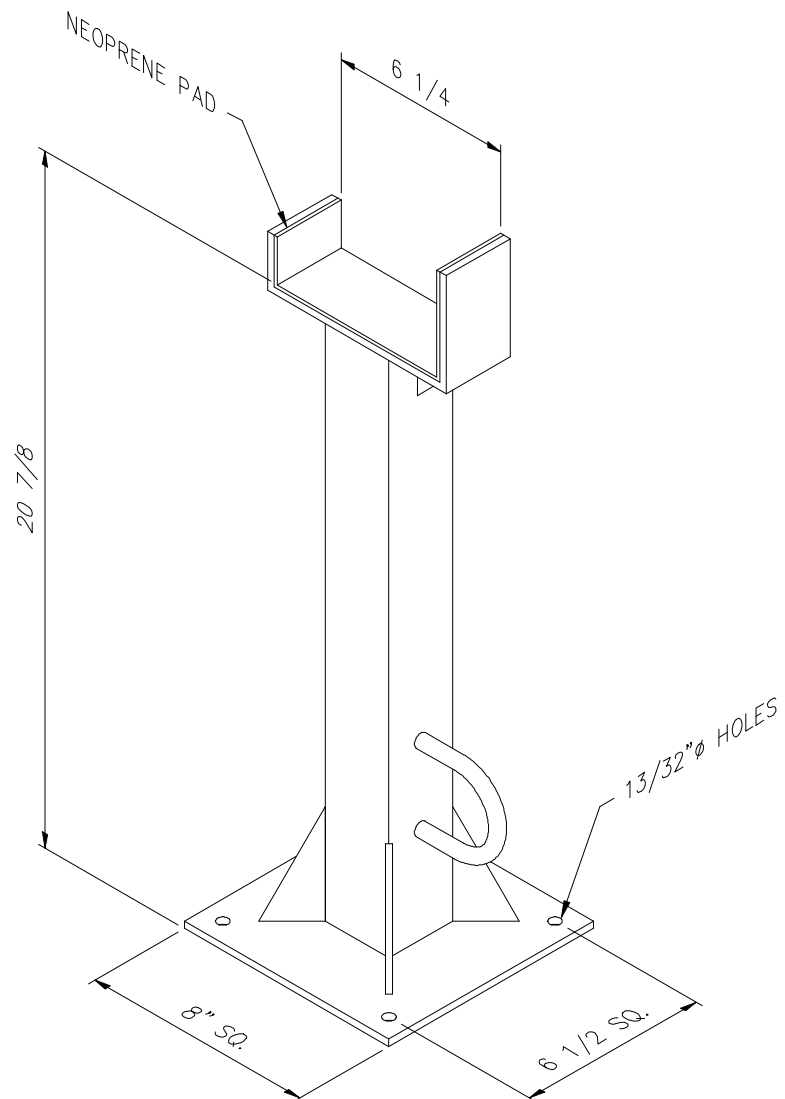

**Suggested Boom Support:
Auto Crane P/N 726175**

GENERAL ASSEMBLY - UNIT LESS BOOM

P/N 404065 - MODEL 4004H

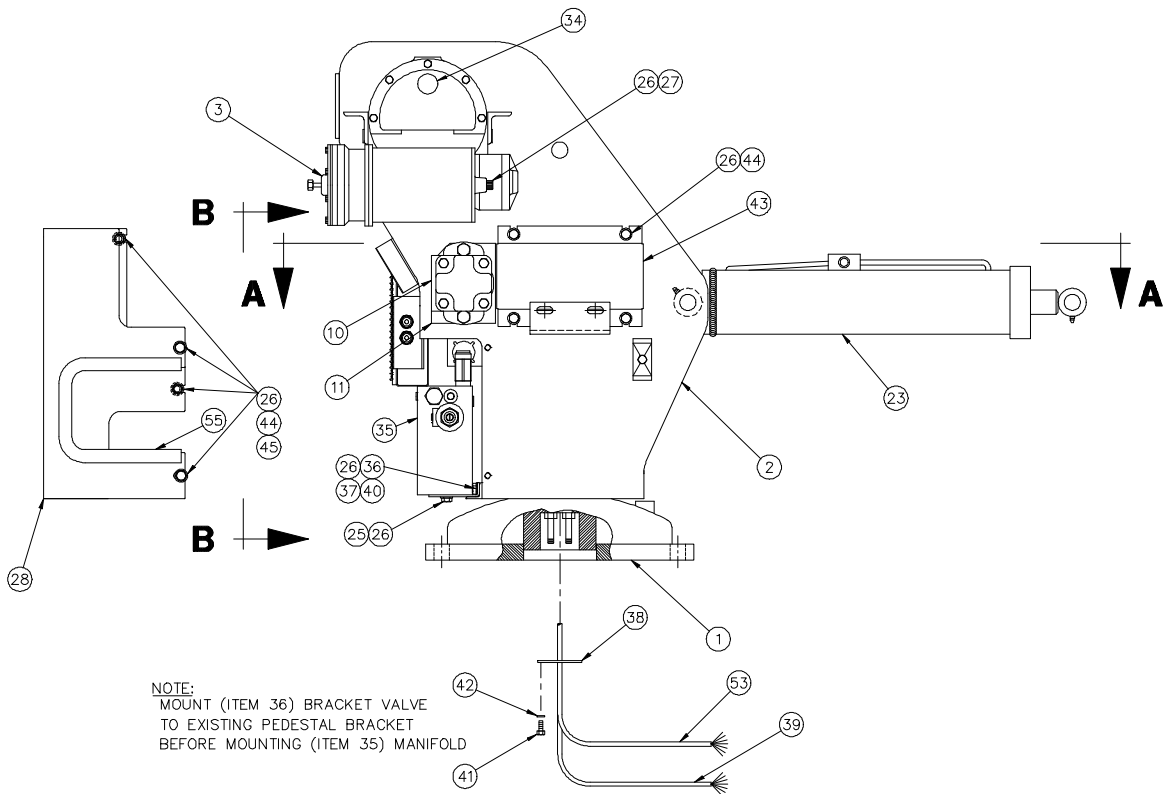
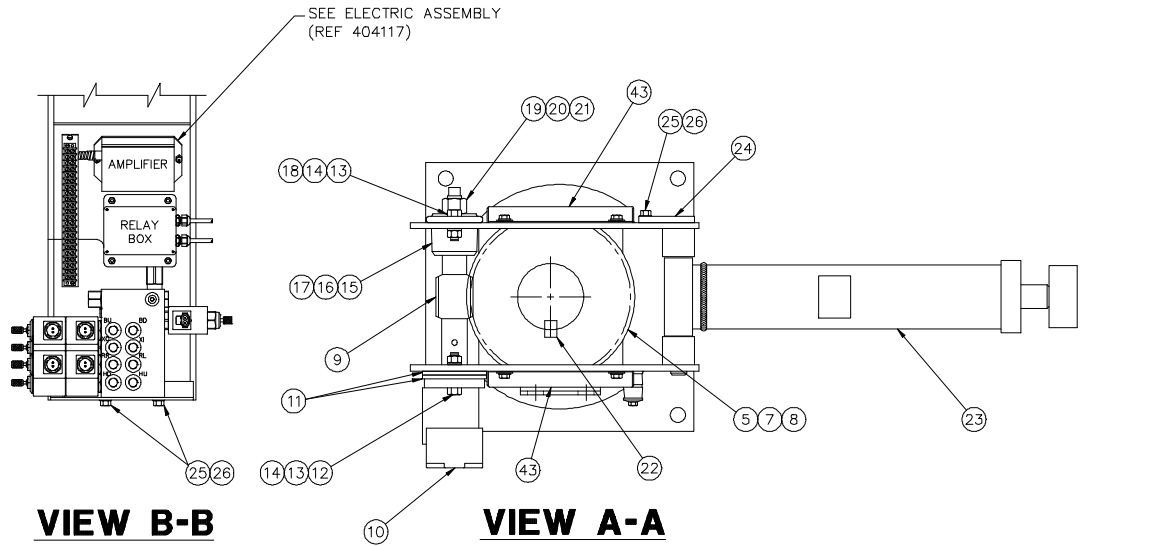

GENERAL ASSEMBLY - UNIT LESS BOOM

P/N 404065 - MODEL 4004H

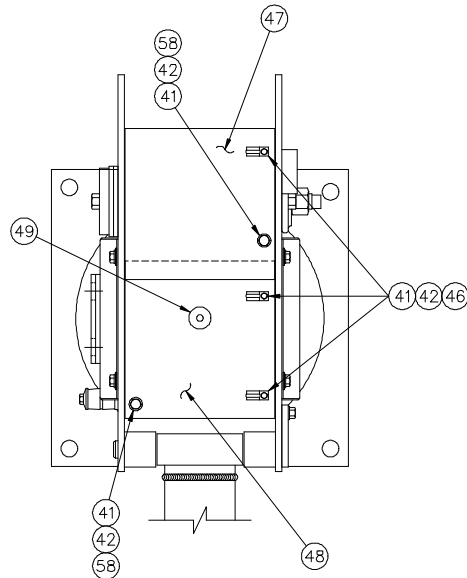

VIEW C-C

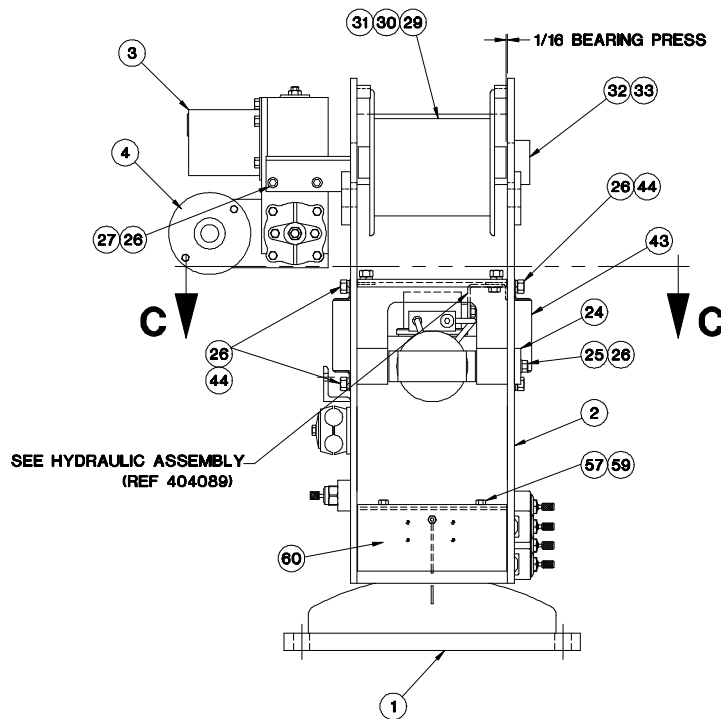

FRONT VIEW

GENERAL ASSEMBLY - UNIT LESS BOOM

P/N 404065 - MODEL 4004H

<u>ITEM</u>	<u>QTY</u>	<u>P/N</u>	<u>DESCRIPTION</u>
1	1	404087	PEDESTAL
2	1	404020	SIDE PLATES/QUILL HOUSING WELDMENT
3	1	480075	HOIST ACTUATOR
4	1	320741	MOTOR HOIST
5	2	404017	ROTATION BEARING
7	2	404028	RETAINING RING GEAR
8	1	404016	WORM GEAR
9	1	404015	WORM
10	1	320740	ROTATION MOTOR
11	2	330484	SPACER
12	2	011603	CAPSCREW 1/2 UNC x 1 3/4
13	4	021500	LOCK WASHER 1/2
14	4	017701	NUT 1/2 UNC
15	2	330486	OIL SEAL
16	2	330485	BEARING
17	1	330472	HOUSING
18	2	010201	CAPSCREW 1/2 UNC x 1 1/2
19	1	330483	SPACER
20	1	019000	HEX LOCK NUT 7/8 NF
21	1	239300	GREASE ZERK
22	1	340602	KEY 3/4 SQ x 1
23	1	404005	BOOM UP CYLINDER
24	1	360624	PEDESTAL/CYLINDER PIN
25	3	366158	CAPSCREW 3/8 UNC x 3/4 G8
26	19	021100	LOCK WASHER 3/8
27	4	404081	SOCKET HEAD SCREW 3/8 UNC x 7/8
28	1	404128	VALVE COVER
29	1	360543	HOIST DRUM
30	1	480094	KEY 3/8 SQ x 6 1/4
31	2	480073	WINCH SHAFT SPACER
32	2	400500	BEARING
33	2	330468	SPLIT-LOCK COLLAR
34	1	360848	PLASTIC PLUG - FOR 1 HOLE

GENERAL ASSEMBLY - UNIT LESS BOOM

P/N 404065 - MODEL 4004H

<u>ITEM</u>	<u>QTY</u>	<u>P/N</u>	<u>DESCRIPTION</u>
35	1	320725	MANIFOLD
36	1	404096	VALVE MOUNTING BRACKET
37	2	330371	CAPSCREW 3/8 UNC x 1
38	1	404132	HYDRAULIC SWIVEL BRACKET
39	1	REF	POWER CONDUCTOR (340638)
40	2	330372	HEX NUT 3/8 UNC GR5
41	5	005401	CAPSCREW 1/4 UNC x 5/8
42	8	020200	LOCK WASHER 1/4
43	2	404094	WORM GEAR COVER
44	14	008401	CAPSCREW 3/8 UNC x 1 1/2
45	4	021200	FLAT WASHER 3/8
46	3	000115	JIFFY CLIP #115
47	1	404098	LEFT HAND PEDESTAL COVER
48	1	404103	RIGHT HAND PEDESTAL COVER
49	1	371024	RUBBER GROMMET
50	1	404134	SLIDE STOP PIN
51	1	404135	SLIDE STOP WASHER
52	1	330370	CAPSCREW 3/8 UNC x 7/8 GR8
53	1	404146	GROUND WIRE HARNESS
54	1	404130	ROTATION STOP PLATE
55	1.651ft	750743	DOOR GASKET
57	2	002006	SELF TAPPING CAPSCREW #10 x 1/2
58	2	020400	FLAT WASHER 1/4
59	2	019800	LOCK WASHER #10
*60	1	REF	LIMIT SWITCH PANEL ASSEMBLY (404155)+

*Base mounting hardware to truck frame
Item Numbers not used: 6, 56.

PEDESTAL ASSEMBLY

MODEL 4004H

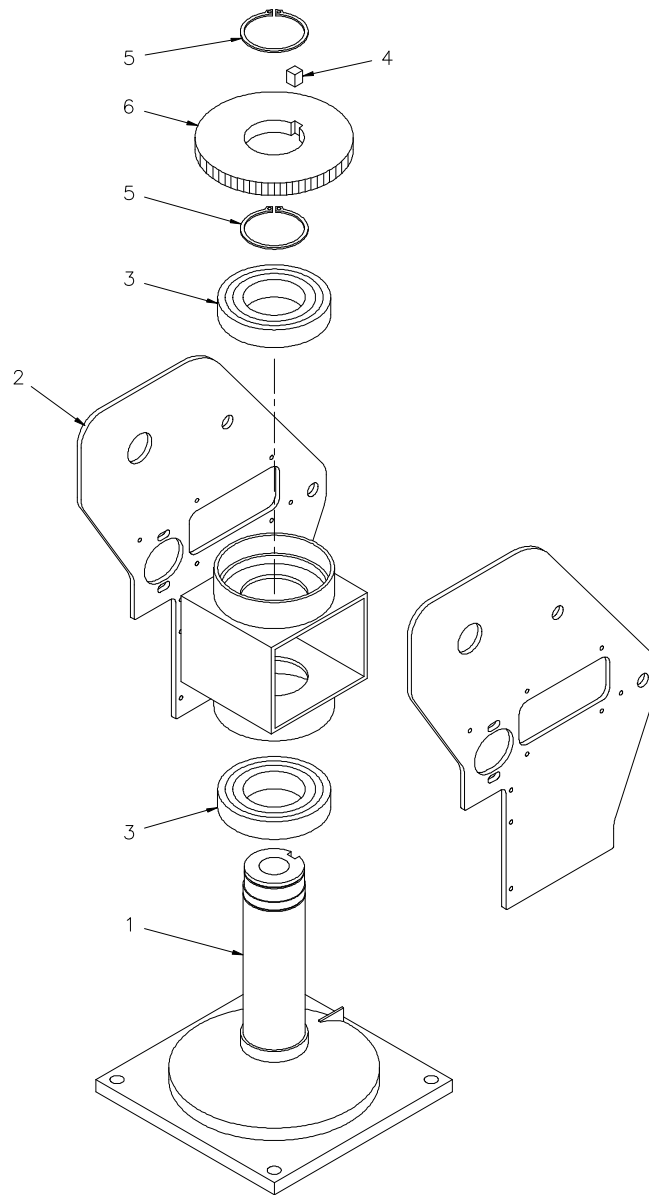

<u>ITEM</u>	<u>QTY</u>	<u>P/N</u>	<u>DESCRIPTION</u>
1	1	404025	PEDESTAL
2	1	404020	SIDE PLATES/QUILL HOUSING
3	2	404017	ROTATION BEARING
4	1	340602	KEY 3/4 SQ x 1
5	2	404028	GEAR RETAINING RING
6	1	404016	WORM GEAR

BOOM ASSEMBLY (10-16-20)

P/N 404110 - MODEL 4004H

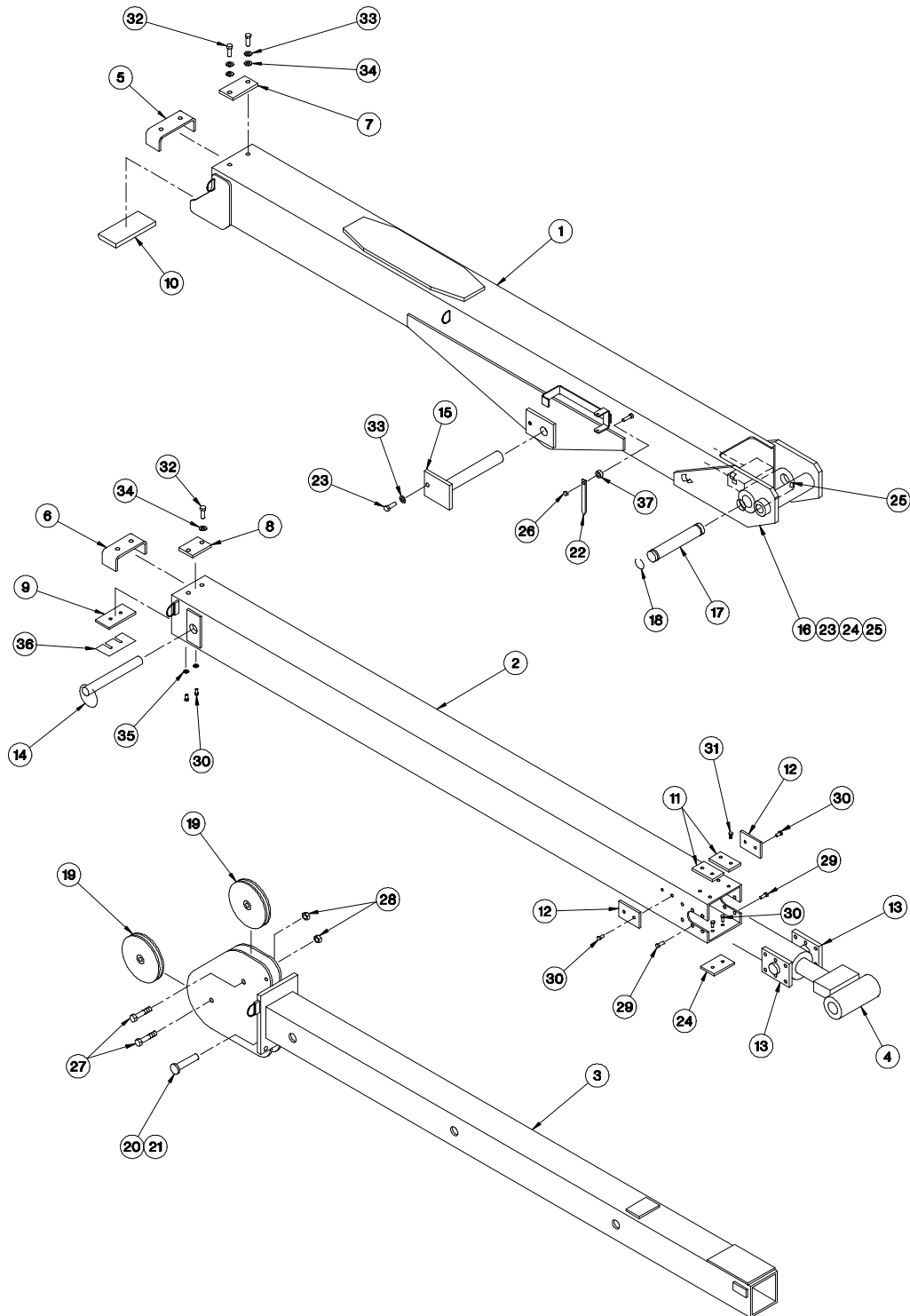

BOOM ASSEMBLY (10-16-20)

P/N 404110 - MODEL 4004H

<u>ITEM</u>	<u>QTY</u>	<u>P/N</u>	<u>DESCRIPTION</u>
1	1	404083	LOWER BOOM
2	1	404085	CENTER BOOM
3	1	404035	MANUAL BOOM
4	1	360152	BOOM EXTENSION CYLINDER
5	1	366183	CENTER BOOM STOP
6	1	366112	UPPER BOOM STOP
7	1	366201	BOOM TOP PAD
8	1	366202	BOOM TOP PAD
9	1	366199	BOOM PAD
10	1	366187	RETAINER LOWER PAD
11	2	480036	CENTER BOOM TOP PAD
12	3	366186	CENTER BOOM PAD
13	2	366184	EXTENSION CYLINDER RETAINER
14	1	366190	PIN ASSEMBLY w/ LANYARD
15	1	360819	BOOM CYLINDER PIN
16	1	360625	LOWER BOOM PIVOT PIN
17	1	366193	EXTENSION CYLINDER PIN
18	2	480029	RETAINING RING
19	2	240236	SHEAVE ASSEMBLY
20	1	360814	CROWN PIN
21	1	360124	HITCH PIN
22	1	360038	ANGLE INDICATOR
23	2	366158	HEX HD SCREW 3/8 NC x 3/4 GR8
24	1	480120	BOOM PAD
25	1	239000	GREASE ZERK
26	1	016300	HEX LOCK NUT 1/4 NC
27	2	011511	HEX HD SCREW 1/2 NF x 2 1/4 GR5
28	2	017700	HEX LOCK NUT 1/2 NF
29	12	008400	HEX HD SCREW 3/8 NC x 3/4
30	6	007808	HEX HD SCREW 5/16 NC x 1/2
31	6	005406	HEX HD SCREW 1/4 NF x 1/2
32	4	008800	HEX HD SCREW 3/8 NC x 1
33	6	021100	LOCK WASHER 3/8
34	6	021200	FLAT WASHER 3/8
35	2	020600	LOCK WASHER 5/16
36	A/R	480037	SHIM
37	1	360849	PLASTIC SPACER 1/4 Ø

BOOM ASSEMBLY (10-16)

P/N 404115 - MODEL 4004H

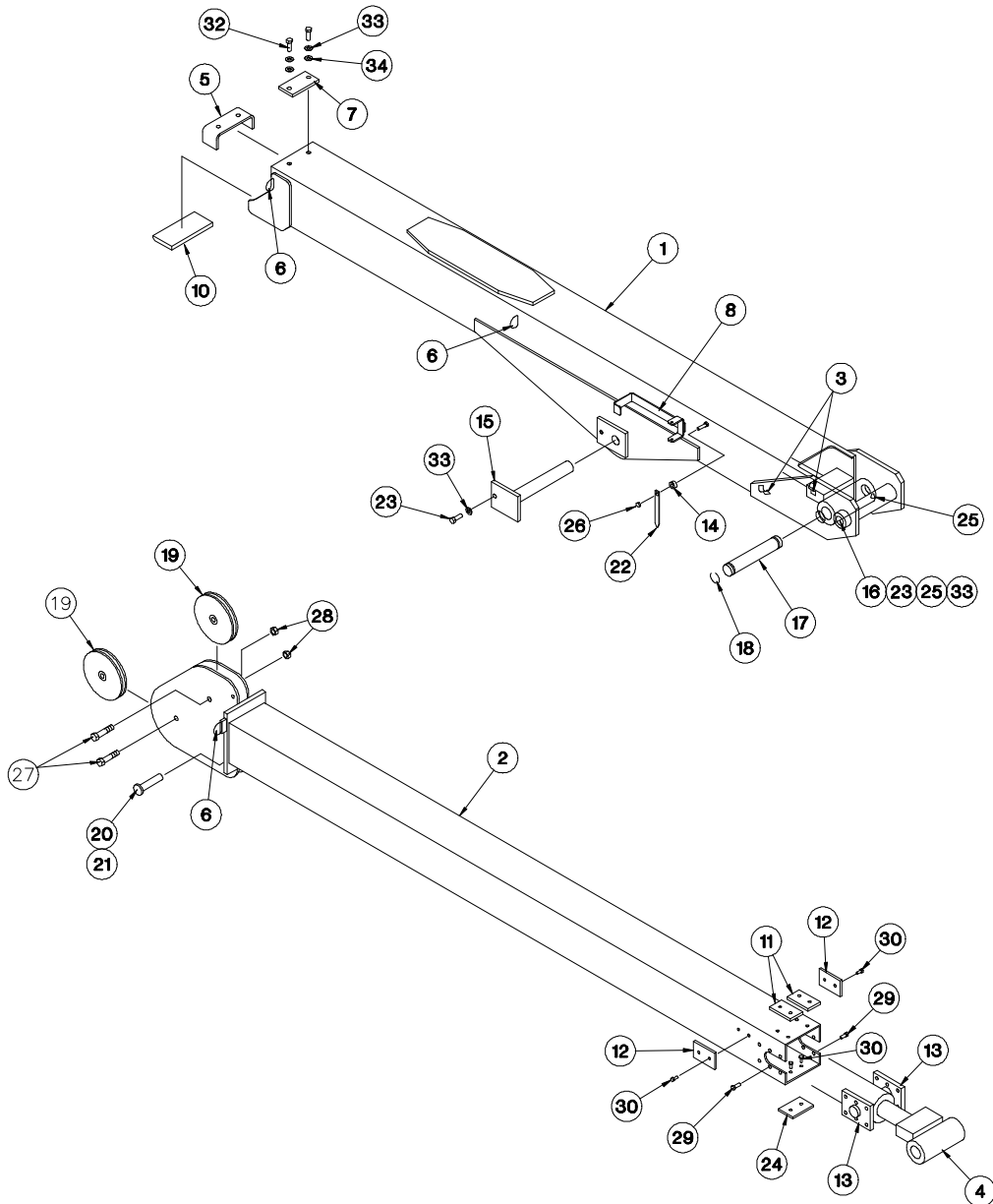

BOOM ASSEMBLY (10-16)

P/N 404115 - MODEL 4004H

<u>ITEM</u>	<u>QTY</u>	<u>P/N</u>	<u>DESCRIPTION</u>
1	1	404083	LOWER BOOM
2	1	404085	CENTER BOOM
3	2	000115	CLIP <i>(not included)</i>
4	1	360152	BOOM EXTENSION CYLINDER
5	1	366183	CENTER BOOM STOP
6	4	366108	D-RING <i>(not included)</i>
7	1	366201	BOOM TOP PAD
8	1	320551	CORD REEL BRACKET <i>(not included)</i>
9	1	330603	SEAL KIT
10	1	366187	RETAINER LOWER PAD
11	2	480036	CENTER BOOM TOP PAD
12	2	366186	CENTER BOOM PAD
13	2	366184	EXTENSION CYLINDER RETAINER
14	1	360849	PLASTIC SPACER 1/4 Ø
15	1	360819	BOOM CYLINDER PIN
16	1	360625	LOWER BOOM PIVOT PIN
17	1	366193	EXTENSION CYLINDER PIN
18	2	480029	RETAINING RING
19	2	240236	SHEAVE ASSEMBLY
20	1	360814	CROWN PIN
21	1	360124	HITCH PIN
22	1	360038	ANGLE INDICATOR
23	2	366158	HEX HD SCREW 3/8 NC x 3/4 GR8
24	1	480120	BOOM PAD
25	1	239000	GREASE ZERK
26	1	016300	HEX LOCK NUT 1/4 NC
27	2	011511	HEX HD SCREW 1/2 NF x 2 1/4 GR5
28	2	017700	HEX LOCK NUT 1/2 NF
29	12	008400	HEX HD SCREW 3/8 NC x 3/4
30	4	007808	HEX HD SCREW 5/16 NC x 1/2
31	6	005406	HEX HD SCREW 1/4 NF x 1/2
32	4	008800	HEX HD SCREW 3/8 NC x 1
33	4	021100	SP LK WASHER 3/8 SAE
34	6	021200	FL WASHER 3/8

2-BLOCK ASSEMBLY

MODEL 4004H

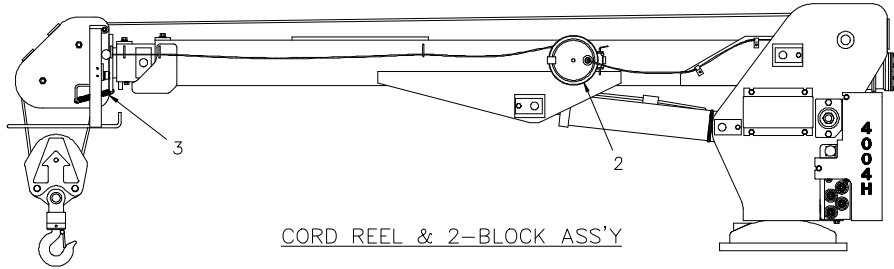

CORD REEL & 2-BLOCK ASS'Y

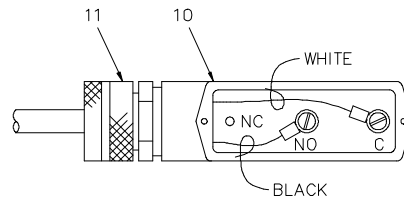

REFERENCE-SWITCH WIRING

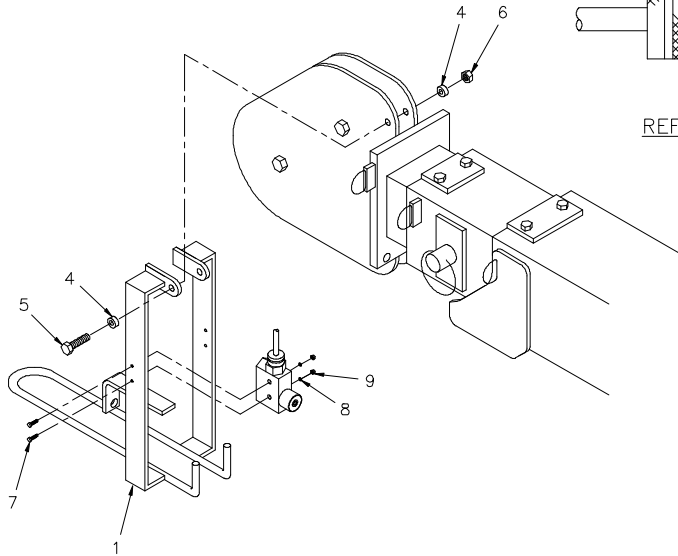

<u>ITEM</u>	<u>QTY</u>	<u>P/N</u>	<u>DESCRIPTION</u>
1	1	360823	2-BLOCK WELDMENT
2	1	366973-001	CORD REEL ASSY w/WEATHER PACK CONNECTORS
3	1	360824	2-BLOCK SPRING
4	2	360852	PLASTIC SPACER 3/8 Ø
5	1	009800	CAPSCREW 3/8 NF x 3 1/2
6	1	017400	LOCK NUT 3/8 NF
7	2	000610	ROUND HEAD SCREW #6 NC x 1 1/2
8	2	019600	LOCK WASHER #6
9	2	015400	NUT #6 NC
10	1	646900	SWITCH
11	1	642908	CORD CONNECTOR

HOIST ACTUATOR

P/N 480075 - MODEL 4004H

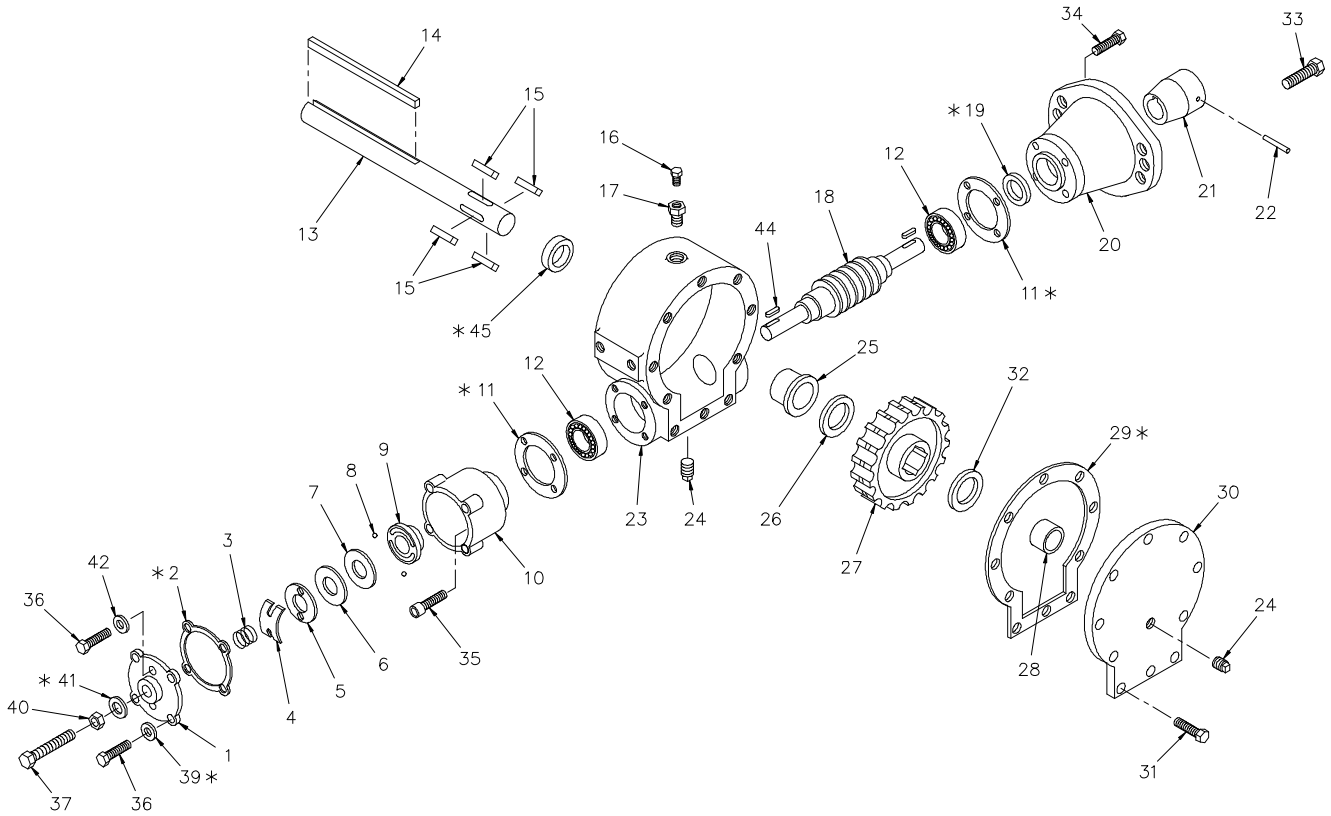

HOIST ACTUATOR

P/N 480075 - MODEL 4004H

<u>ITEM</u>	<u>QTY</u>	<u>P/N</u>	<u>DESCRIPTION</u>
1	1	360450	WORM BRAKE COVER
*2	1	360359	GASKET
3	1	360368	SPRING
4	1	360367	FLAT SPRING
5	1	360342	RETAINER PLATE
6	1	360364	THRUST PLATE
7	1	360331	CAM PLATE
8	2	360345	BRAKE BALL
9	1	360339	BRAKE HUB
10	1	360336	BRAKE HOUSING
*11	2	360358	GASKET
12	2	360346	BEARING
13	1	480078	OUTPUT SHAFT
14	1	480094	KEY 3/8 SQ
15	4	360464	BARTH KEY
16	1	360360	RELIEF FITTING
17	1	360361	REDUCER
18	1	360344	RIGHT HAND WORM
*19	1	360365	OIL SEAL
20	1	360330	ADAPTER
21	1	360332	COUPLING
22	1	360363	SPIROL PIN
23	1	360461	GEAR HOUSING
24	2	360362	PIPE PLUG
25	1	360348	BUSHING
26	1	360369	THRUST WASHER
27	1	360460	RIGHT HAND GEAR
28	1	360462	BUSHING
*29	1	360459	GASKET
30	1	360458	COVER
31	10	360350	HEX HD CAPSCREW 1/4 NC x 3/4 GR5
32	1	360466	THRUST WASHER
33	2	010202	HEX HD CAPSCREW 1/2 NC x 1
34	4	360352	SOC HD CAPSCREW 1/4 NC x 1 3/4 GR5

HOIST ACTUATOR

P/N 480075 - MODEL 4004H

<u>ITEM</u>	<u>QTY</u>	<u>P/N</u>	<u>DESCRIPTION</u>
35	4	360463	SOC HD CAPSCREW 1/4 NC x 7/8
36	6	360453	HEX HD w/ NYLOCK CAPSCREW 1/4 NC x 1 GR5
37	1	360456	HEX HD CAPSCREW 1/8 NC x 1 1/2 GR5
38	-	-	-
*39	4	360465	THREAD SEAL
40	1	360353	HEX JAM NUT 3/8 NC
*41	1	360371	THREAD SEAL
42	2	360455	FLAT ALUMINUM WASHER 1/4
43	-	-	-
44	2	360341	KEY
*45	1	360366	OIL SEAL
46	1	480306	SEAL AND GASKET KIT

NOTE: ITEMS MARKED WITH AN ASTERISK (*) ARE INCLUDED IN SEAL & GASKET KIT P/N 480306 (ITEM 46).

AUTOMATIC SAFETY BRAKE ASSEMBLY

(OIL COOLED) HOIST

ASSEMBLY INSTRUCTIONS:

1. Winch has right hand worm and gear. Cable spools over drum. Use number one slots for brake balls(7) in cam plate(2).
2. Install brake hub(5) through brake housing(4) on winch worm with key.
3. Assemble balls(7) in cam plate(2) using hard grease to hold balls in place.
4. Place cam plate(2) on brake hub(5), matching its holes with the balls.
5. Install thrust plate(16).
6. Thread capscrew(10) with jam nut (12) and thread seal (11) through housing cover(3).
7. Place gasket(15) on housing cover(3).
8. Install coil spring(9) on capscrew(10).
9. Install flat spring(1) on capscrew(10).
10. Secure retainer plate(6) and flat spring(1) to housing cover(3) using capscrews(8) and washers(14).
11. Using capscrews(8) and thread seals(13) attach housing cover(3) to brake housing(4).
12. Test brake by shifting winch to UP then DOWN to see if brake is working in proper rotation. If not, remove housing cover(3) and locate brake balls(7) in opposite set of slots of cam plate(2).
13. Adjust to suit by tightening or loosening capscrew(10) on outside of housing cover(3). When proper adjustment is obtained, secure capscrew(10) with jam nut(12).

AUTOMATIC SAFETY BRAKE ASSEMBLY (OIL COOLED) HOIST

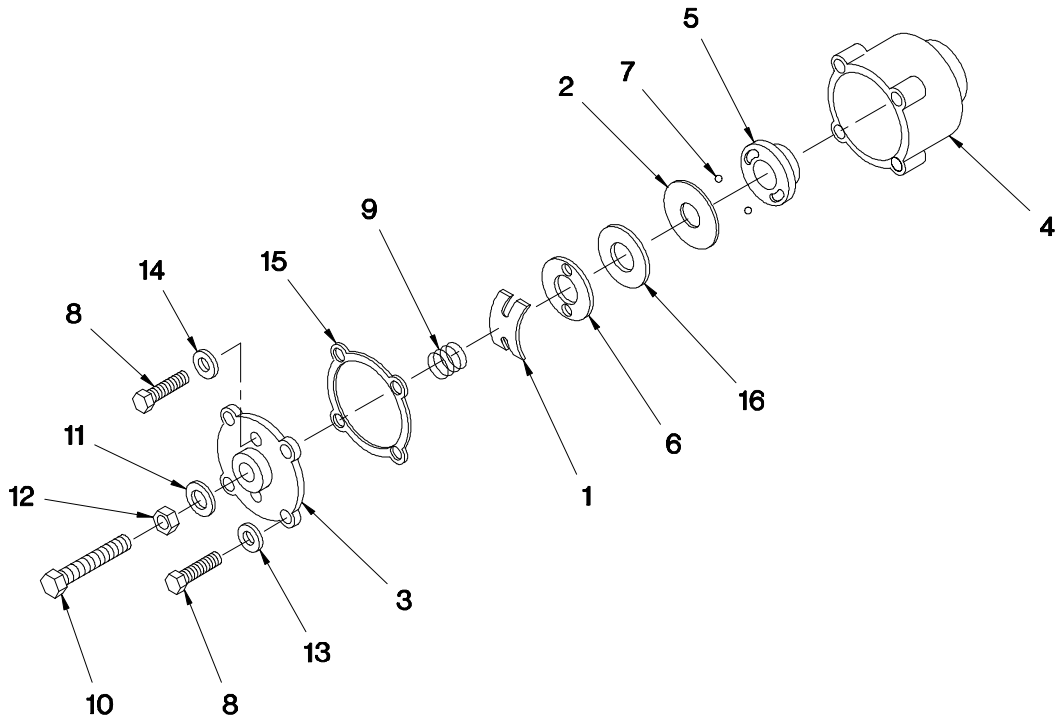

<u>ITEM</u>	<u>QTY</u>	<u>P/N</u>	<u>DESCRIPTION</u>
1	1	360367	FLAT SPRING
2	1	360331	CAM PLATE
3	1	360450	HOUSING COVER
4	1	360336	BRAKE HOUSING
5	1	360339	BRAKE HUB
6	1	360342	RETAINER PLATE
7	2	360345	BRAKE BALL
8	6	360453	CAPSCREW 1/4 NC x 1
9	1	360368	COIL SPRING
10	1	360456	CAPSCREW 3/8 NC x 1 1/2
11	1	360371	THREAD SEAL
12	1	360353	JAM NUT 3/8 NC
13	4	360465	THREAD SEAL
14	2	360455	WASHER FLAT 1/4 ALUM
15	1	360359	GASKET
16	1	360364	THRUST PLATE

HYDRAULIC TURNER ASSEMBLY

MODEL 4004H

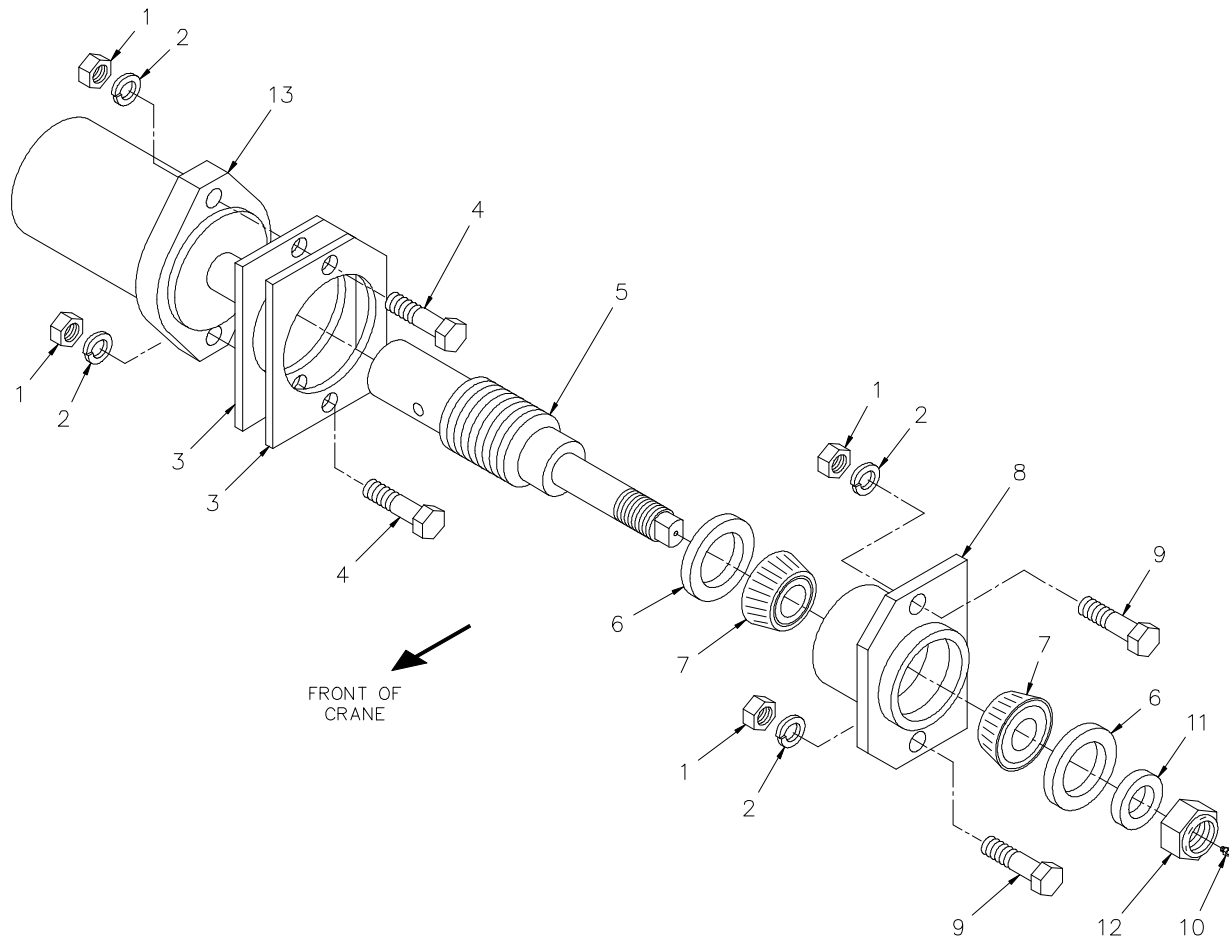

<u>ITEM</u>	<u>QTY</u>	<u>P/N</u>	<u>DESCRIPTION</u>
1	4	017701	NUT 1/2 NC
2	4	021500	LOCK WASHER 1/2
3	2	330484	SPACER
4	2	011603	CAPSCREW 1/2 NC x 1 3/4
5	1	404015	WORM SHAFT ASSEMBLY
6	2	330486	OIL SEAL
7	2	330485	BEARING
8	1	320760	BEARING HOUSING
9	2	010201	CAPSCREW 1/2 NC x 1 1/2
10	1	239300	GREASE ZERK
11	1	330483	SPACER
12	1	019000	LOCK NUT 7/8 NF
13	1	320740	ROTATION MOTOR

TRAVELING BLOCK ASSEMBLY

P/N 360480 - MODEL 4004H

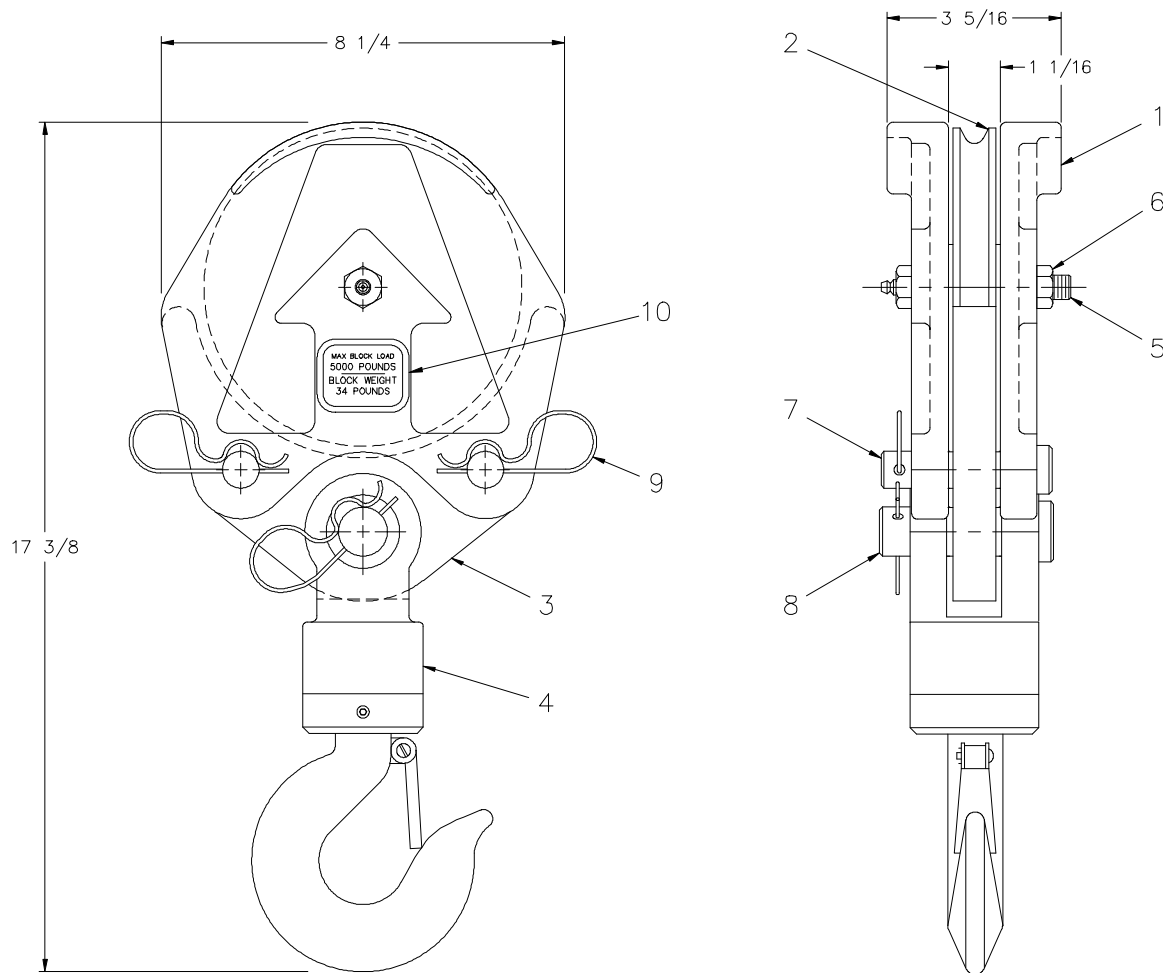

<u>ITEM</u>	<u>QTY</u>	<u>P/N</u>	<u>DESCRIPTION</u>
1	2	480362	SIDE PLATE
2	1	240236	SHEAVE ASSEMBLY
3	1	480364	LOWER TACKLE
4	1	480371	SWIVEL HOOK - 3 TON
5	1	480372	BOLT x 3 1/4 GR8 w/ GREASE ZERK
6	1	017800	LOCK NUT 1/2 NC
7	2	480367	BLOCK PIN
8	1	480368	SWIVEL HOOK PIN
9	3	360124	HITCH PIN
10	2	360480-100	MAXIMUM LOAD DECAL

GENERAL DIMENSIONS

4004H 10-16-20

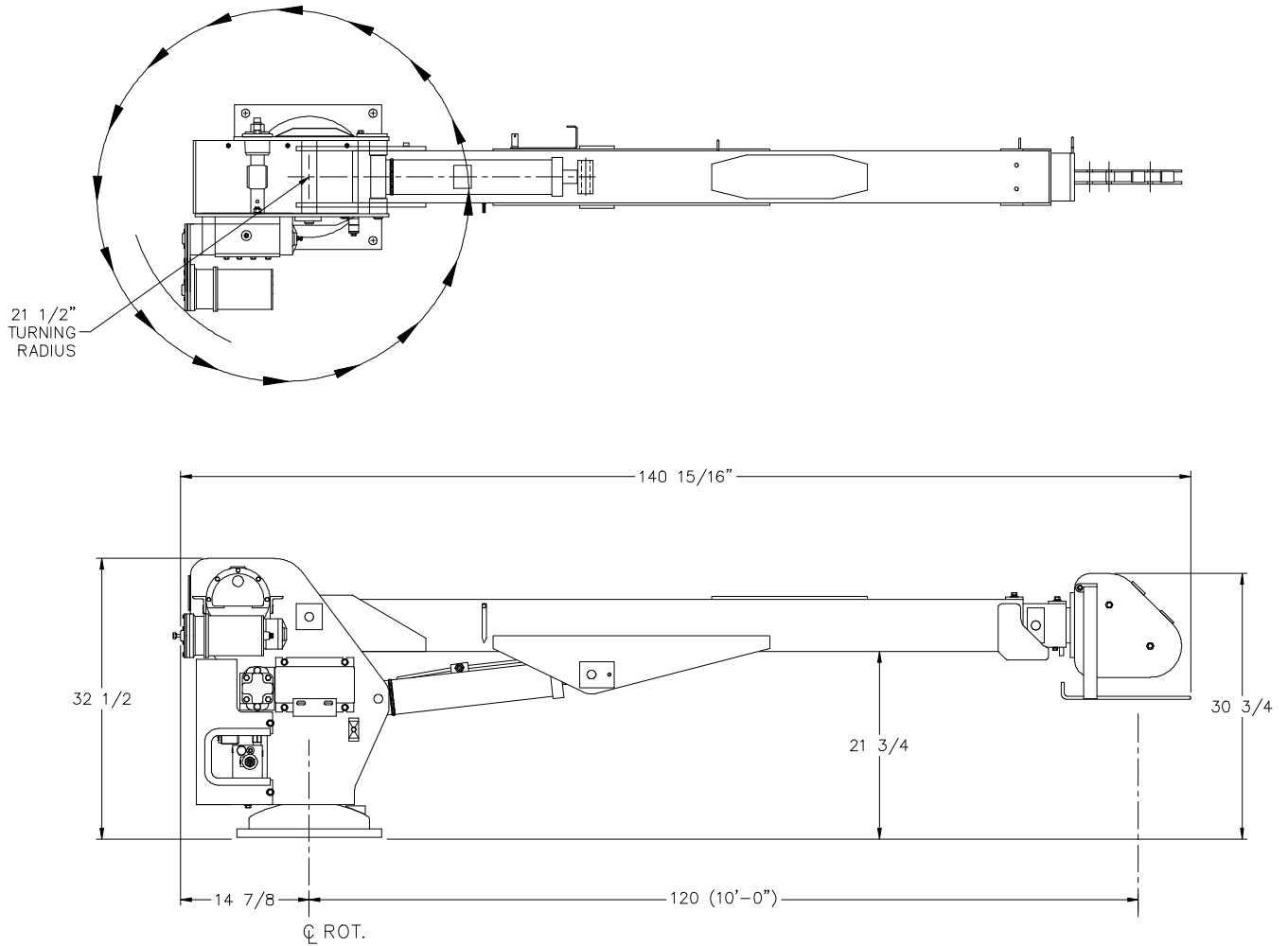

NOTES:

- A. MAX TURNING RADIUS AT ROTATION MOTOR = 13"
- B. MAX TURNING RADIUS AT HOIST ACTUATOR = 21 1/2"

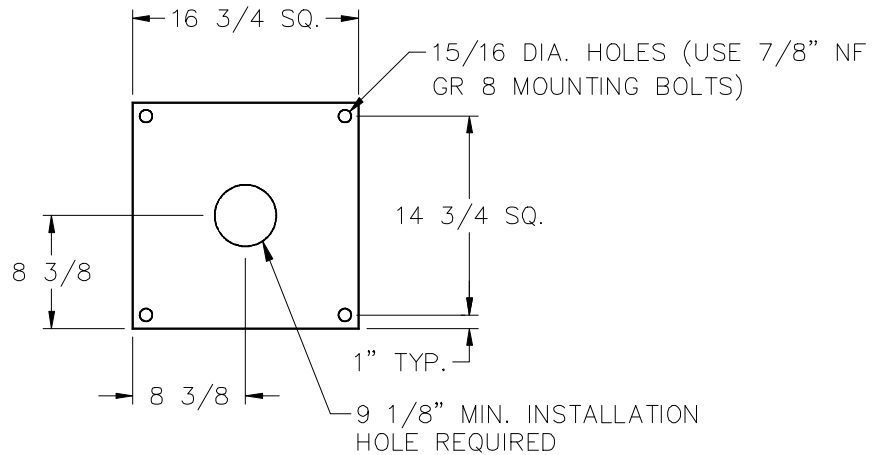

GENERAL DIMENSIONS

4004H 10-16

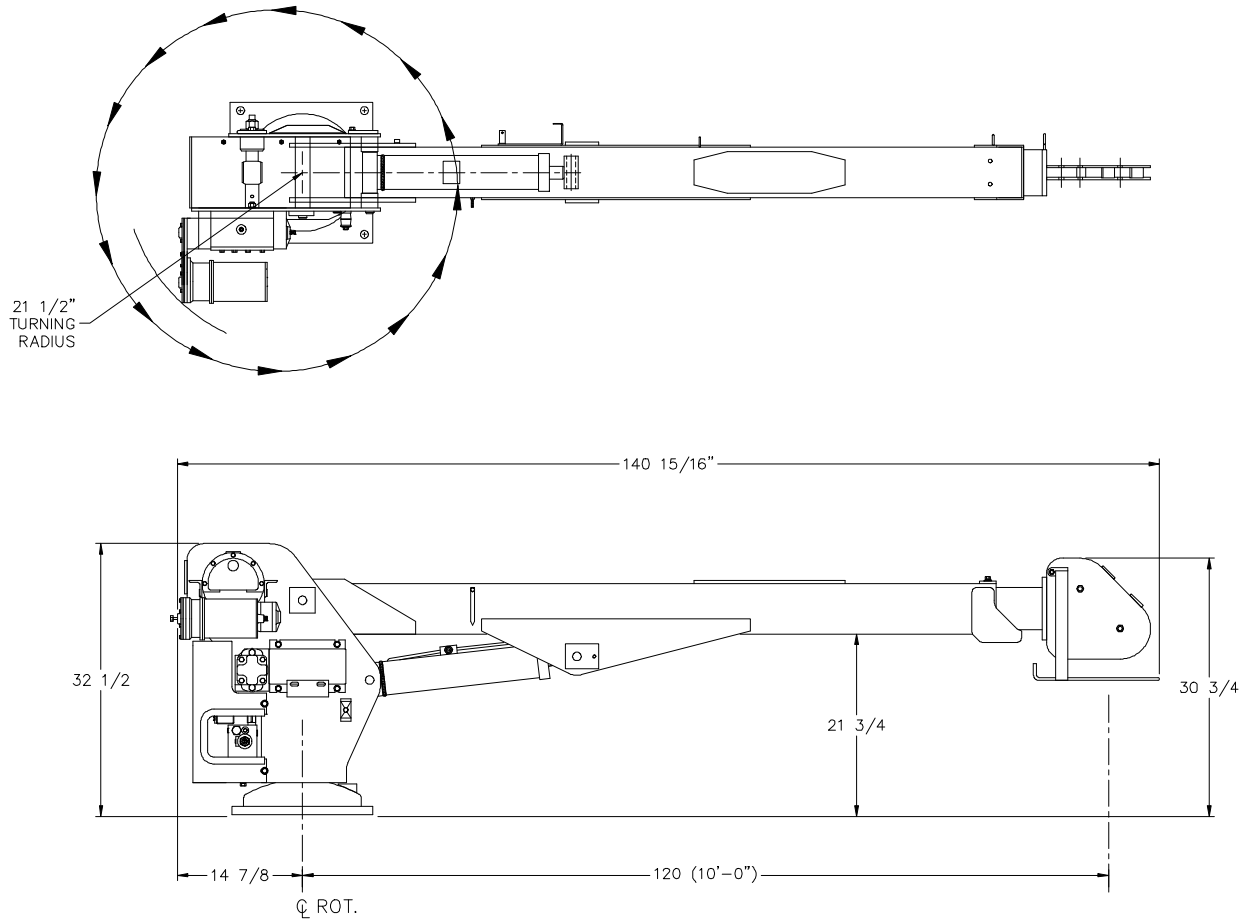

NOTES:

- A. MAX TURNING RADIUS AT ROTATION MOTOR = 13"
- B. MAX TURNING RADIUS AT HOIST ACTUATOR = 21 1/2"

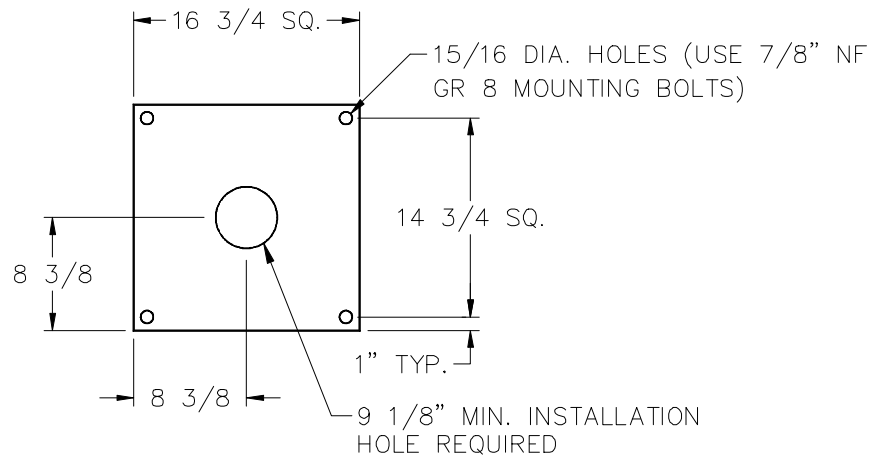

CRANE WIRING

P/N 404117 - 4004H SERIES

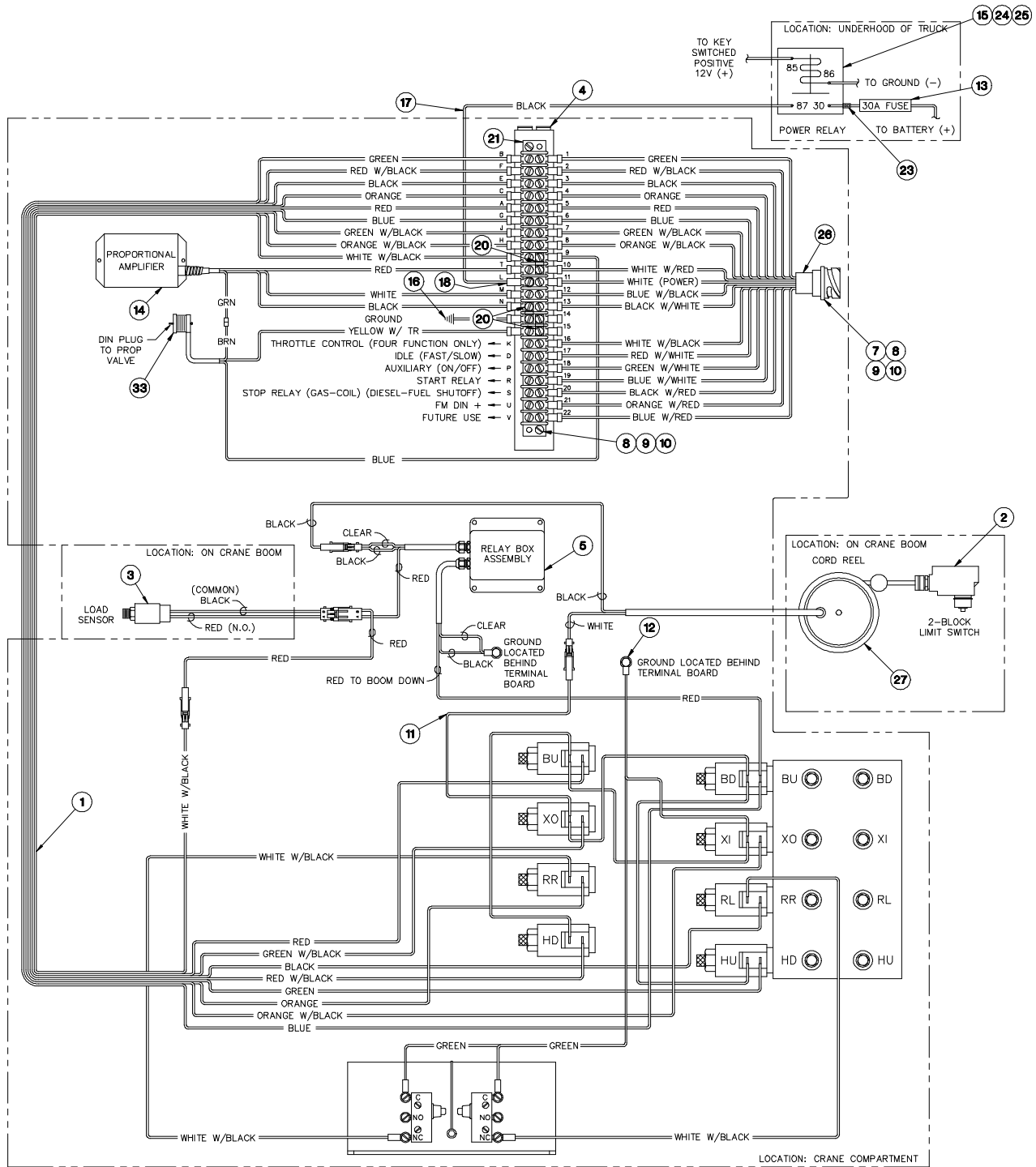

CRANE WIRING

P/N 404117 - 4004H SERIES

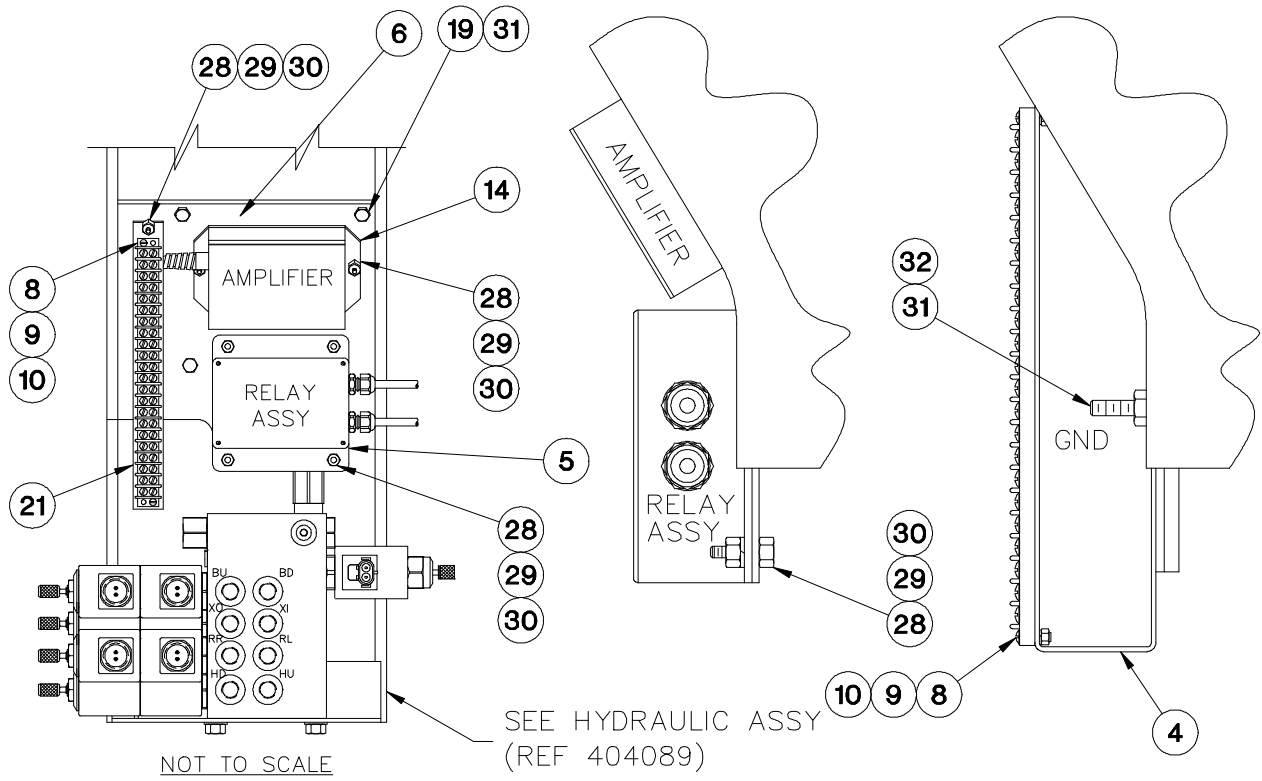

CRANE WIRING

P/N 404117 - 4004H SERIES

* DECAL IS LOCATED INSIDE OF COVER

<u>ITEM</u>	<u>QTY</u>	<u>P/N</u>	<u>DESCRIPTION</u>
1	REF	404123	WIRING HARNESS
2	1	646900	SWITCH
3	1	404158	LOAD SENSOR ASSEMBLY
4	1	404142	TERMINAL BOARD BRACKET
5	1	404113	RELAY BOX ASSEMBLY
6	1	404141	WIRING HARNESS BRACKET
7	1	366097	PENDANT RECEPTACLE CAP
8	4	000404	PAN HD SCREW #6 x 5/8
9	4	019600	LOCK WASHER #6
10	4	015400	HEX NUT #6
11	1	404118	WIRE HARNESS w/ WEATHER PACK
12	1	404119	GROUND WIRE HARNESS
13	1	750167	IN LINE 30 AMP FUSE
14	1	404137	PROPORTIONAL AMPLIFIER ASSEMBLY
15	1	320355	RELAY POWER
16	1	480549	16 GA BLACK CONDUCTOR
17	1	340638	POWER CONDUCTOR
18	1	001002	RING TERMINAL
19	4	005500	HEX HD SCREW 1/4 NC x 3/4
20	3	636600	JUMPER
21	1	480494	22 STATION TERMINAL BLOCK
*22	1	REF	ELECTRICAL SCHEMATIC DECAL
23	1	001102	2RC-10 TERMINAL WIRE
24	1	320363	RELAY PLUG
25	5	320357	NON-INSULATED SPADE CONNECTOR
26	1	404114	WIRING HARNESS
27	1	366973-001	CORD REEL ASSEMBLY
28	7	002603	RD HD SCREW #10-32 NF x 2
29	7	015800	HEX NUT #10-32 NF
30	7	019900	FLAT WASHER #10
31	5	020200	LOCK WASHER 1/4
32	1	005800	HEX HD SCREW 1/4 NC x 1 1/2
33	1	404138	DIN CONNECTOR ASSEMBLY

CRANE WIRING IC

P/N 404149 - 4004H SERIES

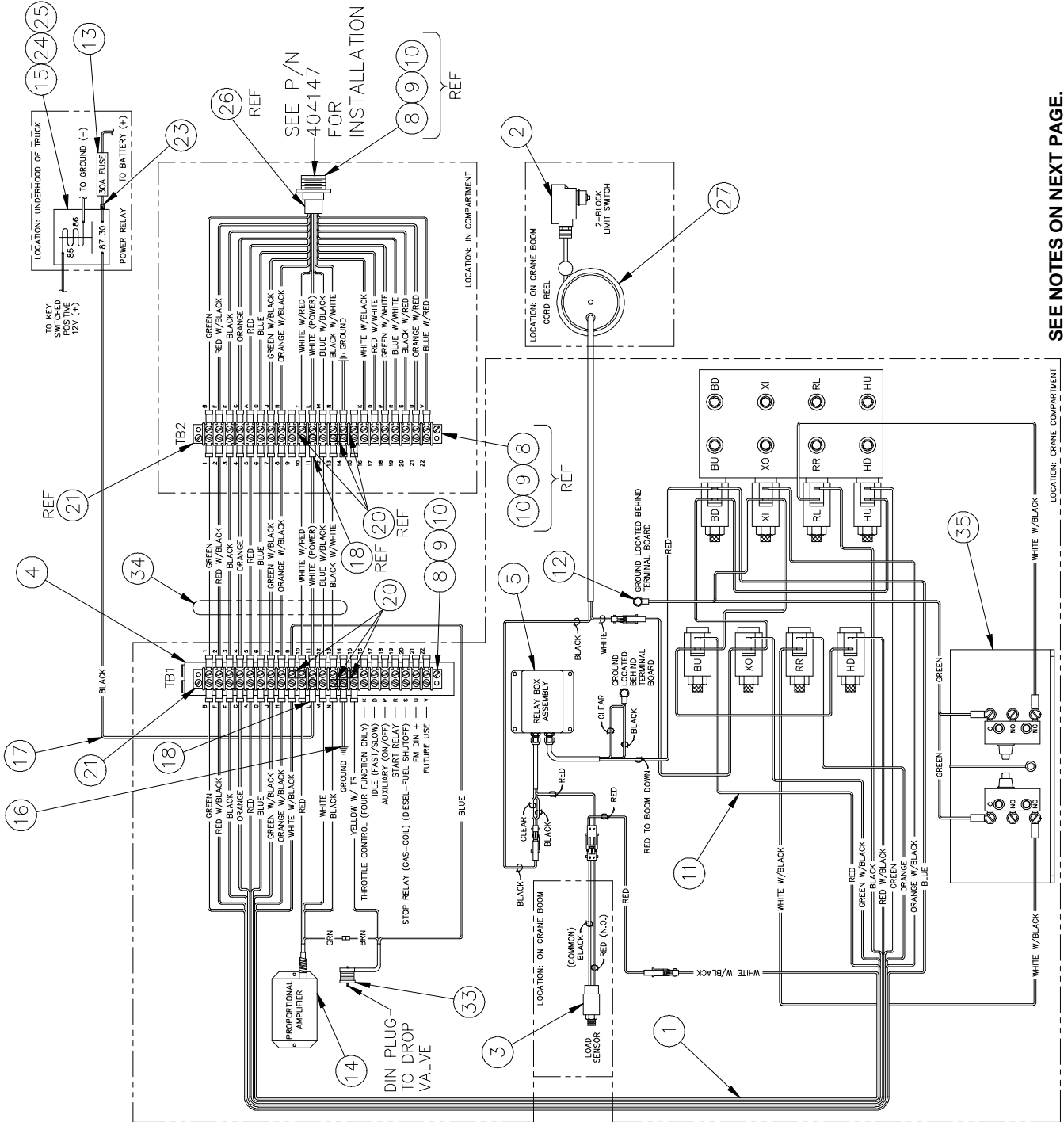

CRANE WIRING IC

P/N 404149 - 4004H SERIES

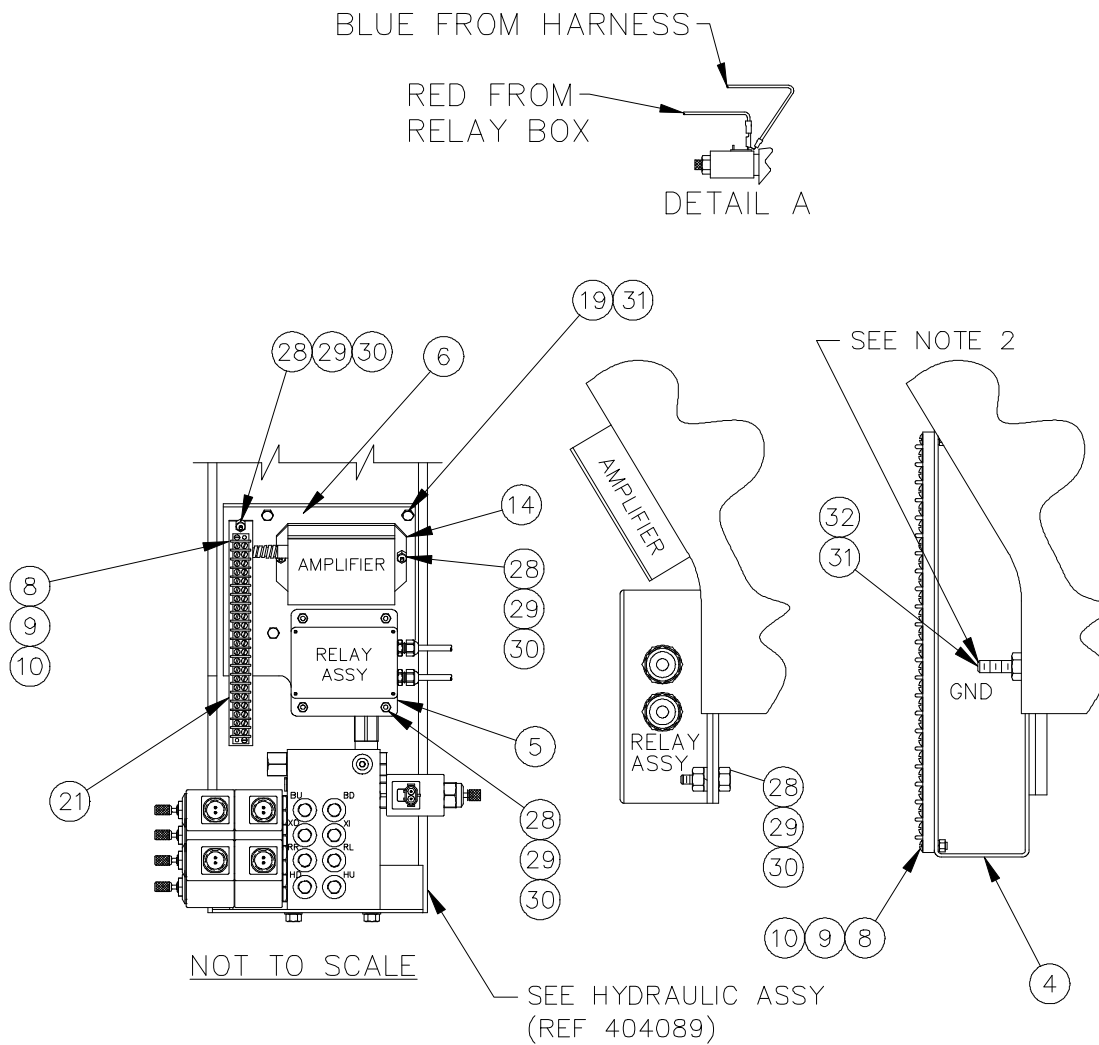

Notes:

1. Mount terminal board bracket, amplifier, & relay assembly with cap screw heads mounted behind wiring harness bracket.
2. 1/4 x 1 1/2 cap screw that mounts terminal bracket is also ground for unit.
3. *Decal is located inside of cover.
4. Mount cover pendant receptacle (Item 7) to bracket on side plate.
5. Similar to 404117.
6. The wiring on this crane are color coded. Do not paint wiring.

CRANE WIRING IC

P/N 404149 - 4004H SERIES

<u>ITEM</u>	<u>QUANTITY</u>	<u>PART NUMBER</u>	<u>DESCRIPTION</u>
1	1	404123	WIRING HARNESS
2	1	646900	SWITCH
3	1	320543	LOAD SENSOR ASSEMBLY
4	1	404142	TERMINAL BOARD BRACKET
5	1	404113	RELAY BOX ASSEMBLY
6	1	404141	WIRING HARNESS BRACKET
7	1	404153	PENDANT RECEPTACLE COVER
8	8	000404	PAN HD SCREW #6 x 5/8
9	8	019600	LOCK WASHER #6
10	8	015400	HEX NUT #6
11	1	404118	WIRE HARNESS w/ WEATHER PACK
12	1	404119	GROUND WIRE HARNESS
13	1	750167	IN LINE 30 AMP FUSE
14	1	404137	PROPORTIONAL AMPLIFIER ASSEMBLY
15	1	320355	RELAY POWER
16	1	480549	16 GA BLACK CONDUCTOR
17	1	340638	POWER CONDUCTOR
18	1	001002	RING TERMINAL
19	4	005500	HEX HD SCREW 1/4 NC x 3/4
20	3	636600	JUMPER
21	1	480494	22 STATION TERMINAL BLOCK
*22	1	404088	ELECTRICAL SCHEMATIC DECAL <i>(not included)</i>
23	1	001102	2RC-10 TERMINAL WIRE
24	1	320363	RELAY PLUG
25	5	320357	NON-INSULATED SPADE CONNECTOR
26	1	680040	WIRING HARNESS <i>(Located inside of cover)</i>
27	1	366973-001	CORD REEL ASSEMBLY
28	7	002603	ROUND HEAD SCREW #10 x 3/4
29	7	015800	NUT #10
30	7	019900	LOCK WASHER #10
31	5	020200	LOCK WASHER 1/4
32	1	005800	CAPSCREW 1/4 UNC x 1 1/2
33	1	404138	DIN CONNECTOR ASSEMBLY
34	1	404148	WIRING HARNESS
35	1	404155	LIMIT SWITCH PANEL ASSEMBLY

IN-COMPARTMENT (IC) PENDANT

P/N 404147

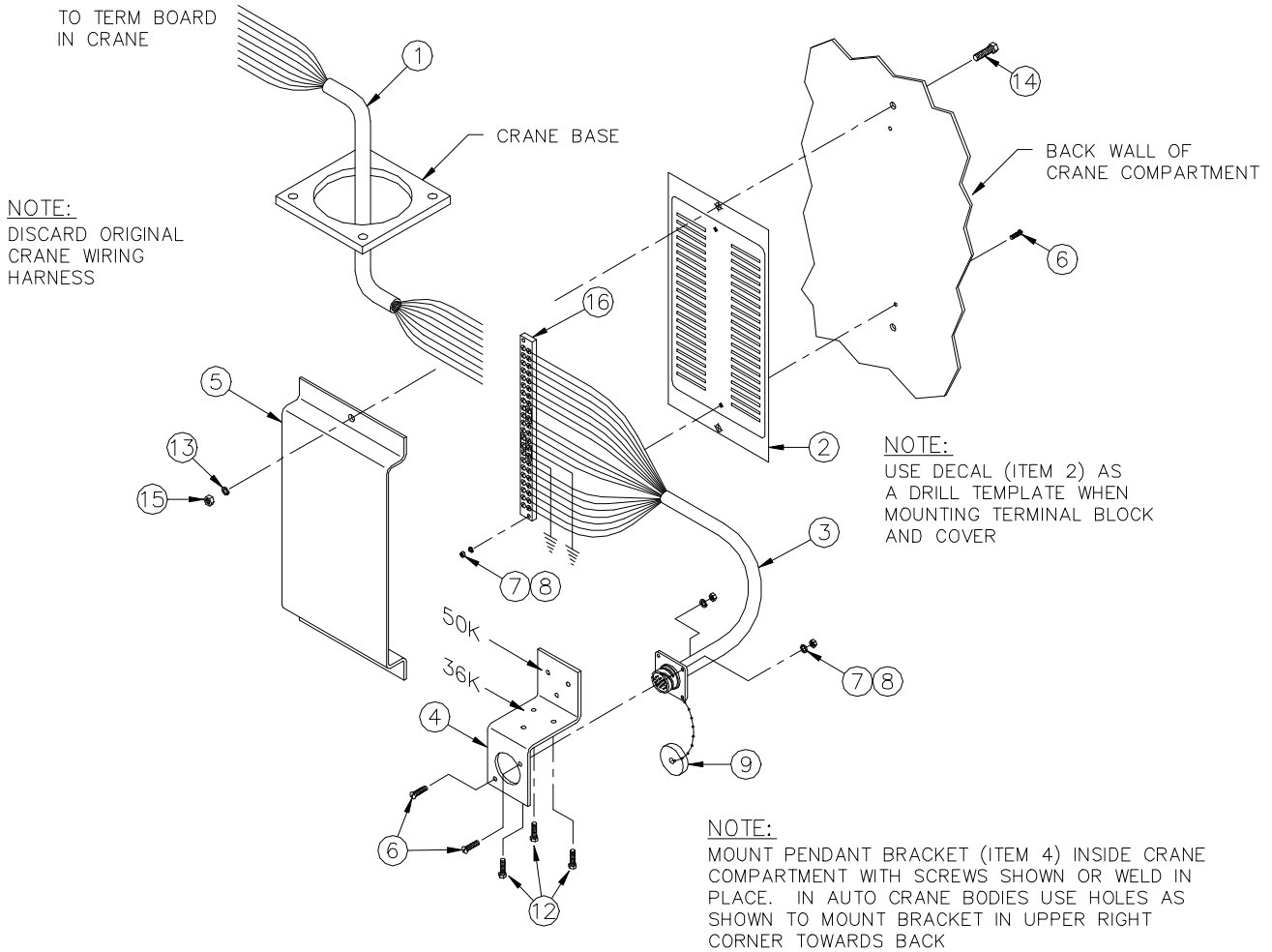

SEE APPROPRIATE CRANE WIRING

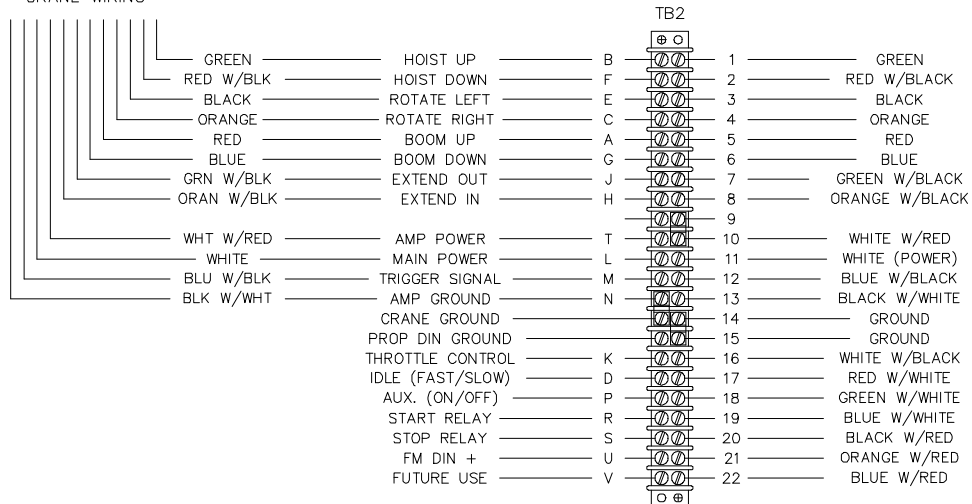

IN-COMPARTMENT (IC) PENDANT

P/N 404147

<u>ITEM</u>	<u>QTY</u>	<u>P/N</u>	<u>DESCRIPTION</u>
1	REF	404148	CRANE PIGTAIL HARNESS
2	1	480490	22 STA TERMINAL BLOCK DECAL
3	1	480491-080	22 STA/19 PIN SOCKET HARNESS
4	1	480626	19 PIN PENDANT BRACKET
5	1	480493	22 STA TERMINAL BLOCK COVER
6	4	000404	RD HD SCREW #6 NC x 5/8
7	4	015400	HEX NUT #6 NC
8	4	019600	SP LK WASHER #6
9	1	366097	19 PIN RECEPTACLE CAP
10	6	750738	STICK ON RETAINER WIRE TIE
11	6	634401	7" WIRE TIE
12	3	330038	HEX HD SELF DRILLING SCREW #10 x 3/4
13	2	020200	SP LK WASHER 1/4
14	2	005500	HEX HD SCREW 1/4 NC x 3/4 GR5
15	2	015900	HEX NUT 1/4 NC
16	1	480494	22 STA TERMINAL BLOCK

PROPORTIONAL 8 FUNCTION PENDANT ASSEMBLY

P/N 680040 - 4004H

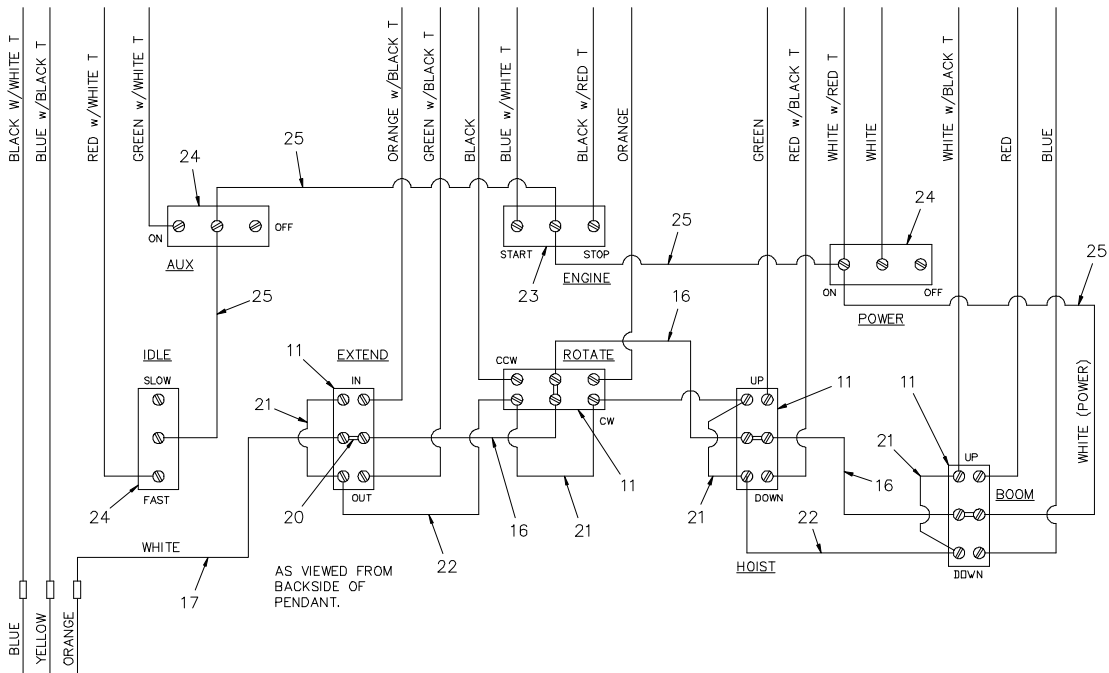
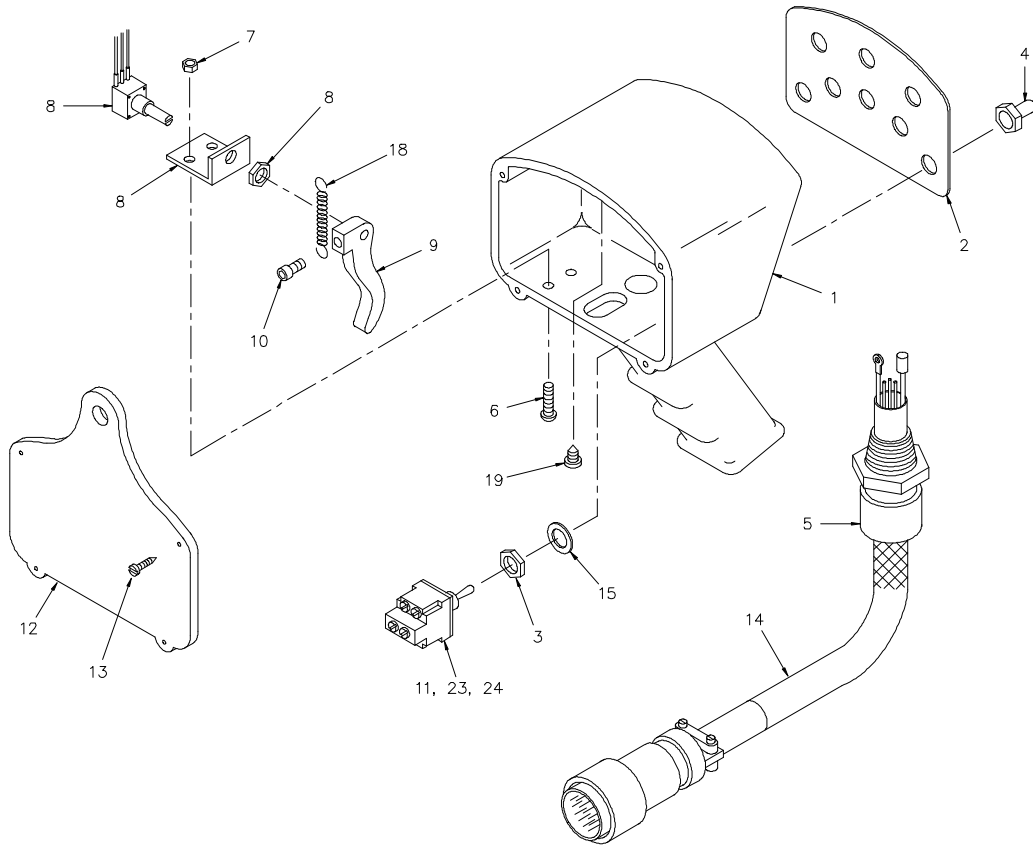

PROPORTIONAL 8 FUNCTION PENDANT ASSEMBLY

P/N 680040 - 4004H

<u>ITEM</u>	<u>QTY</u>	<u>DESCRIPTION</u>
1	1	PENDANT HOUSING
2	1	COVER PLATE DECAL
3	8	NUT
4	8	TOGGLE SWITCH BOOT
5	1	HUBBELL CONNECTOR CORD GRIP
6	2	SCREW #10 NC x 3/4
7	2	HEX LOCK NUT #10 NC
8	1	POTENTIOMETER ASSEMBLY
9	1	TRIGGER
10	1	SOC HD SCREW #10 NF x 5/8
11	4	TOGGLE DPDT SWITCH
12	1	BACK PLATE
13	4	ST RD HD SCREW #6 x 3/4
14	1	CABLE ASSEMBLY
15	8	LOCK WASHER
16	3	CONDUCTOR ASSEMBLY
17	1	CONDUCTOR ASSEMBLY
18	1	TRIGGER RETURN SPRING
19	1	PAN HD ST SCREW #6 x 3/8
20	4	JUMPER
21	4	CONDUCTOR ASSEMBLY 2 1/8
22	3	CONDUCTOR ASSEMBLY 3 1/8
23	1	TOGGLE SPDT SWITCH
24	3	TOGGLE ON/OFF SWITCH
25	1	CONDUCTOR ASSEMBLY
26	2	CABLE TIE

NOTES:

1. Items 5 & 14 may be purchased as replacement Cable Assembly using P/N 380000.
2. Items 6, 7, 8, 9, 10, 18, & 19 may be purchased as a replacement Potentiometer Kit using P/N 380003.
3. Items 1, 2, 12, & 13 may be purchased as a replacement Housing Kit using P/N 380002.
4. Items 3, 4, 11, & 15 may be purchased as a replacement DPDT Switch Kit using P/N 380005.
5. Items 3, 4, 15, & 24 may be purchased as a replacement On/Off Switch Kit using P/N 380001.
6. Items 3, 4, 11, & 23 may be purchased as a replacement SPDT Switch Kit using P/N 380004.

THROTTLE SOLENOID ASSEMBLY

P/N 751140

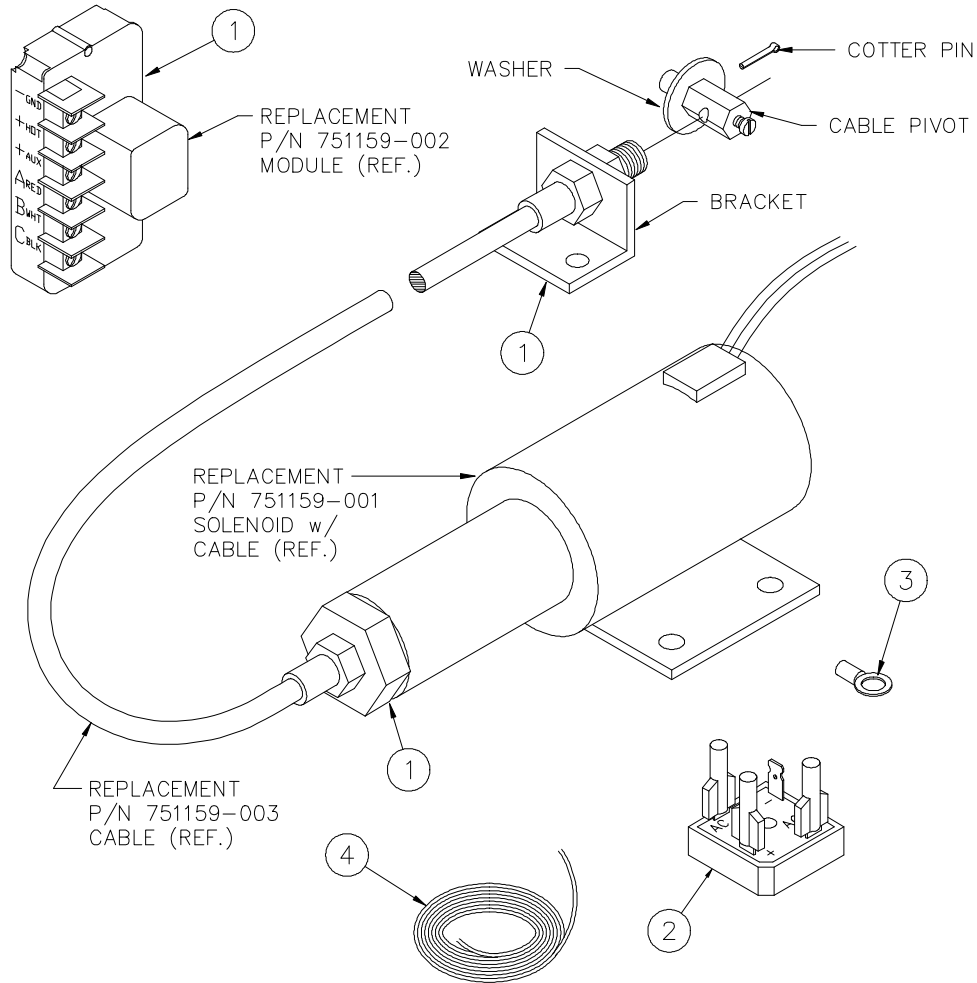

ITEM	QTY	P/N	DESCRIPTION
1	1	751159	12V DC SOLENOID w/ CONTROL MODULE
2	1	751143-001	ISOLATOR MODULE ASSEMBLY
3	8	000101	RING TERMINAL #6
4	15 FT	800603	16 GA WHITE WIRE w/ BLACK TRACER x 15'
5	1	751140-999	WIRING DIAGRAM
6	1	751140-999	INSTALLATION INSTRUCTIONS
7	1	751140-999	TROUBLESHOOTING HINTS

THROTTLE CONTROL SOLENOID

INSTALLATION

LOCATION

Follow these simple rules to properly locate your throttle control kit:

1. Mount the solenoid off the engine but within 46 inches of the throttle lever, to avoid engine vibration and high temperature components (more than 257 °F [125 °C]).
2. Mount control module out of the engine compartment if possible. If not possible, mount the module as far away from high temperature components as possible. Maximum temperature range is 185 °F (85 °C).
3. Route the flexible cable away from high temperature (220 °F [105 °C]) components such as exhaust manifolds.
4. Avoid sharp bends in flexible cable. Bends should form a smooth arc (360° maximum) with a radius of 5 inches minimum.

CONTROLLING THE SOLENOID THROTTLE KIT

The throttle kit can be controlled remotely by applying a low current 12 VDC signal to the module “AUX” terminal.

Examples of activating signals are an air compressor pressure switch or a crane “dump valve” coil.

MOUNTING PROCEDURES

Use the following procedure to mount your throttle controller:

1. Mount the solenoid and control module according to the recommendations in the “LOCATION” instructions
2. Electrically connect the solenoid to the control module and power source according to the wiring diagram.
3. Mount the cable bracket and fasten the cable sheath to the bracket using the collar nut so the sheath does not turn during idle adjustment.

SET HIGH ENGINE IDLE SPEED NOTE:

Do not leave the aluminum adjustment nut tight against the solenoid body since this does not allow the cable to float.

1. Make sure the jam nut is loose and turn the aluminum adjustment nut clockwise until the high engine idle speed is reached.
2. Tighten the jam nut.
3. Check the throttle speed controller operation by rechecking the “normal” engine idle speed with the solenoid deactivated and the high engine idle speed with the solenoid activated.

SYSTEM OPERATION

The control module allows the solenoid to operate as a continuous duty device. When the module is wired as recommended, applying 12 VDC to the “AUX” terminal applies voltage to the hold-in and pull-in coil of the solenoid. After 0.5 to 0.75 seconds, power is automatically removed from the pull-in coil. Power will remain at the hold-in coil until the

THROTTLE CONTROL SOLENOID INSTALLATION

12 VDC signal is removed from the “AUX” terminal.

WARNING!! To avoid control module damage, always disconnect the module when you jump-start the vehicle with voltages that exceed 32 VDC.

TROUBLESHOOTING HINTS

If solenoid will not engage, check the following:

1. Check the stranded pull cable for damage (e.g., melted or crimped sheath)

CONTROL MODULE VOLTAGE MEASUREMENTS

GND	Chassis Ground
+HOT	12 VDC at all times
+AUX	12 VDC required to activate solenoid
A RED	12 VDC when signal is present at “AUX” terminal
B WHT	12 VDC for 0.5 to 0.75 seconds after signal at “AUX” terminal is present
C BLK	Common for solenoid

2. Check the stranded pull cable for binding.
3. Check system voltage at the “+HOT” and “+AUX” terminals.
4. Check module terminals for proper voltage and operation. If the module does not meet the specifications shown below, replace it.
5. Check solenoid resistance (remove wires from module). If resistance is not within specifications listed below, replace the
 - A. White to Black - 0.17 ohms
 - B. Red to Black wire - 13 ohmssolenoid.
6. Make sure you have used the recommended wire length and gage.
7. Be sure cable is not bent beyond guidelines.
8. Check for proper adjustments.
9. Contact Auto Crane Company if you are unable to resolve the problem.

SPEED CONTROL KIT,

P/N 751140

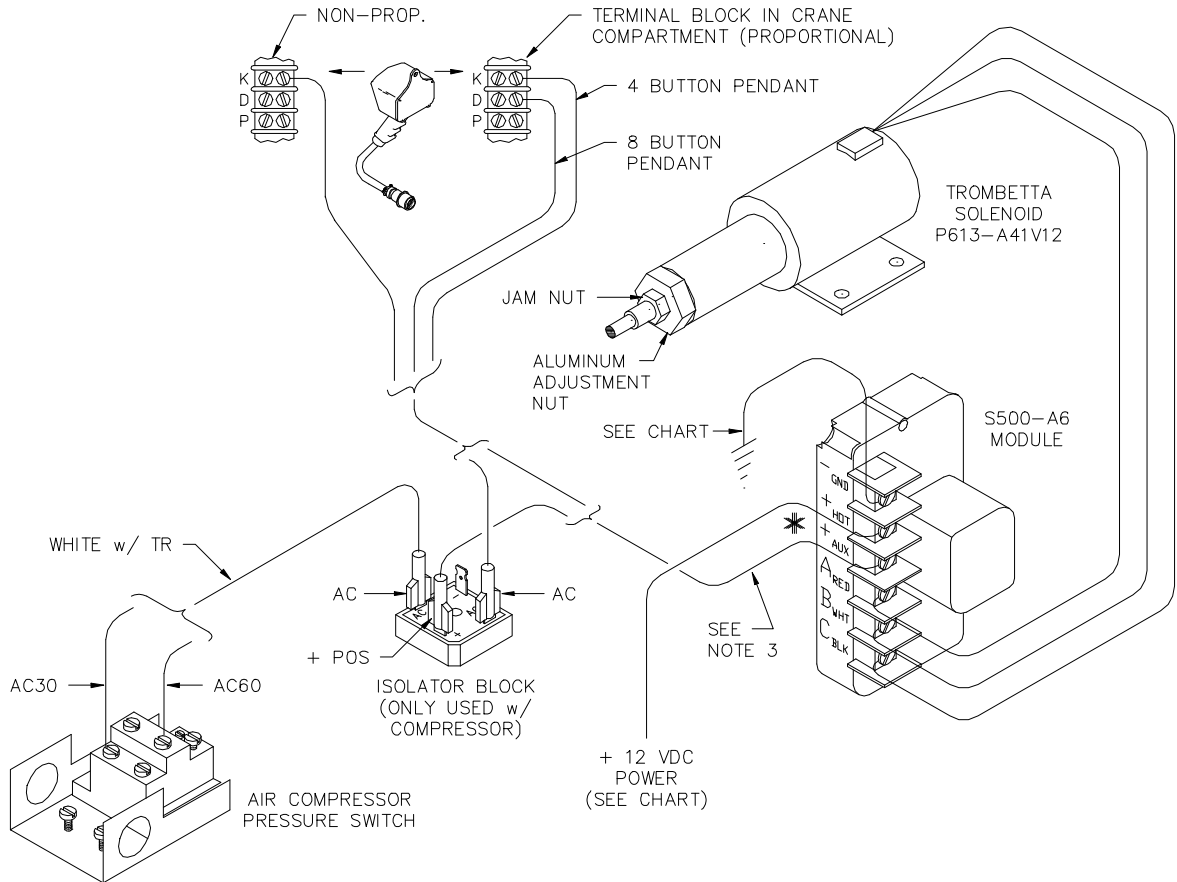

MAXIMUM TOTAL WIRE LENGTH (ft)				
Total of "-GND" and "+HOT" wire length plus "B WHT" and "C BLK" wire length.				
	12 Ga	10 Ga	8 Ga	6 Ga
12VDC	10 ft	16 ft	25 ft	40 ft

NOTES:

1. THIS DIAGRAM SHOWS SPEED CONTROL INSTALLTION WITH OR WITHOUT AN AIR COMPRESSOR. DISREGARD ISOLATOR BLOCK & PRESSURE SWITCH ON DIAGRAM IF NOT USING AN AIR COMPRESSOR.
2. REMOVE METAL JUMPER CLIP FROM CONTROL MODULE IF SO EQUIPPED (S500-A5).
3. * THE WIRE SIZE AND LENGTH TO "AUX" TERMINAL IS NOT CRITICAL BECAUSE OF LOW CURRENT; 16-18 GAGE WIRE MAY BE USED.

ENGINE START/STOP RELAY KIT

P/N 480533

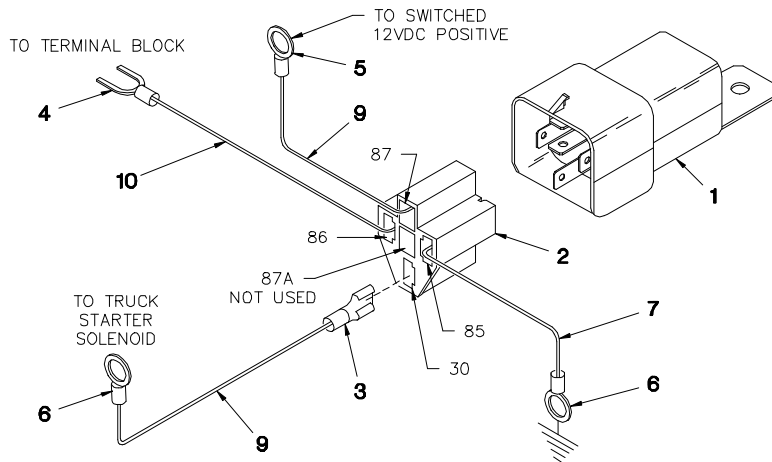

ENGINE START RELAY

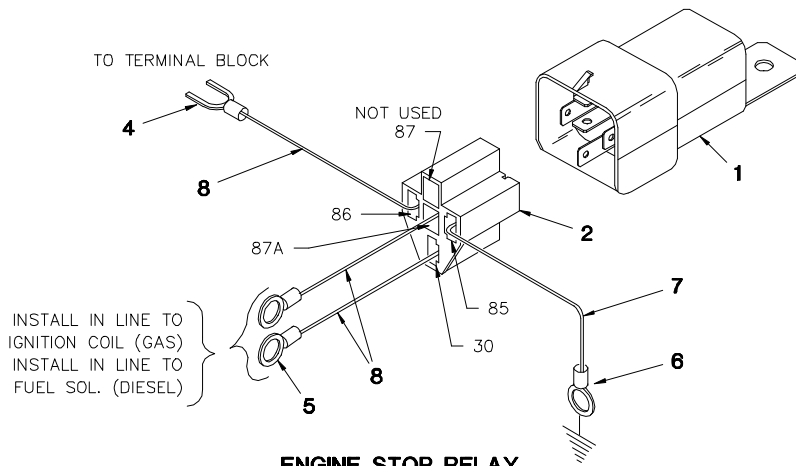

ENGINE STOP RELAY

<u>ITEM</u>	<u>QTY</u>	<u>P/N</u>	<u>DESCRIPTION</u>
1	2	320355	12V RELAY
2	2	320363	RELAY PLUG
3	10	320357	FEMALE SPADE LOCK CONNECTOR
4	2	480495	FLANGED SPADE TERMINAL
5	3	000402	1/4 TERMINAL RING
6	3	000501	5/16 TERMINAL RING
7	6'	800595	GREEN 16 GA WIRE
8	49'	800590	BLACK 16 GA WIRE
9	17'	800593	RED 16 GA WIRE
10	35'	800594	BLUE 16 GA WIRE

AUXILIARY RELAY KIT

P/N 480534

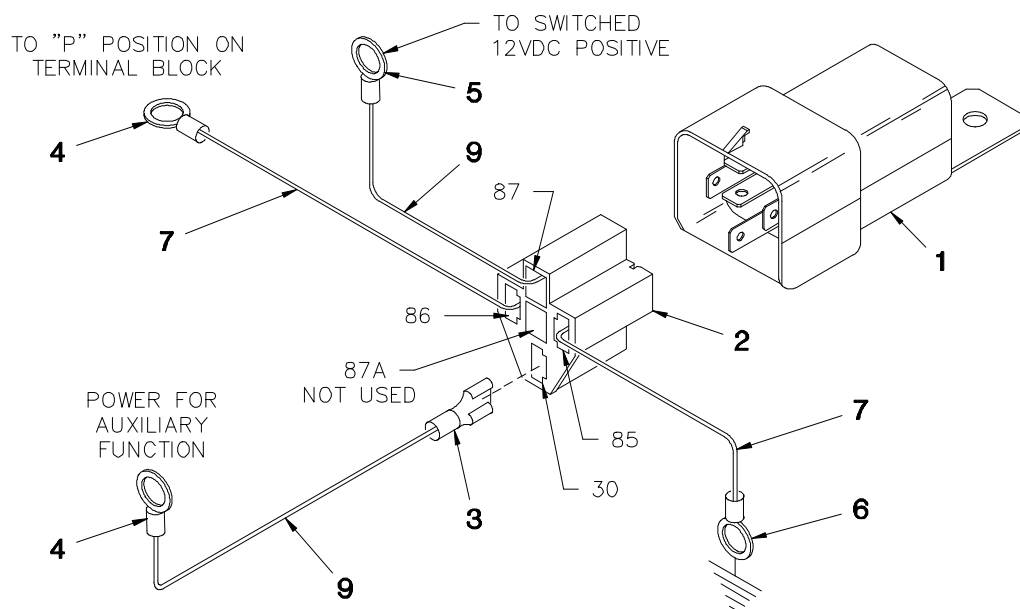

AUXILIARY RELAY

<u>ITEM</u>	<u>QTY</u>	<u>P/N</u>	<u>DESCRIPTION</u>
1	2	320355	12V RELAY
2	2	320363	RELAY PLUG
3	5	320357	FEMALE SPADE LOCK CONNECTOR
4	2	000101	#6 TERMINAL RING
5	1	000402	1/4 TERMINAL RING
6	1	000501	5/16 TERMINAL RING
7	38'	800595	GREEN 16 GA WIRE
8	10'	800593	RED 16 GA WIRE
9	25'	800592	WHITE 16 GA WIRE

HYDRAULIC ASSEMBLY

P/N 404089 - MODEL 4004H

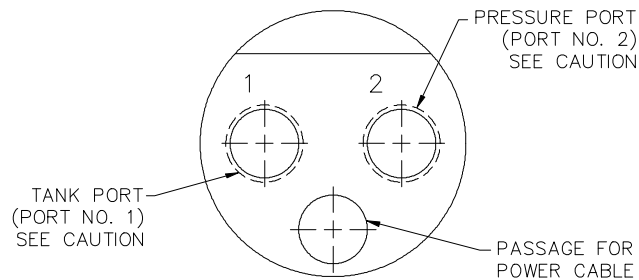
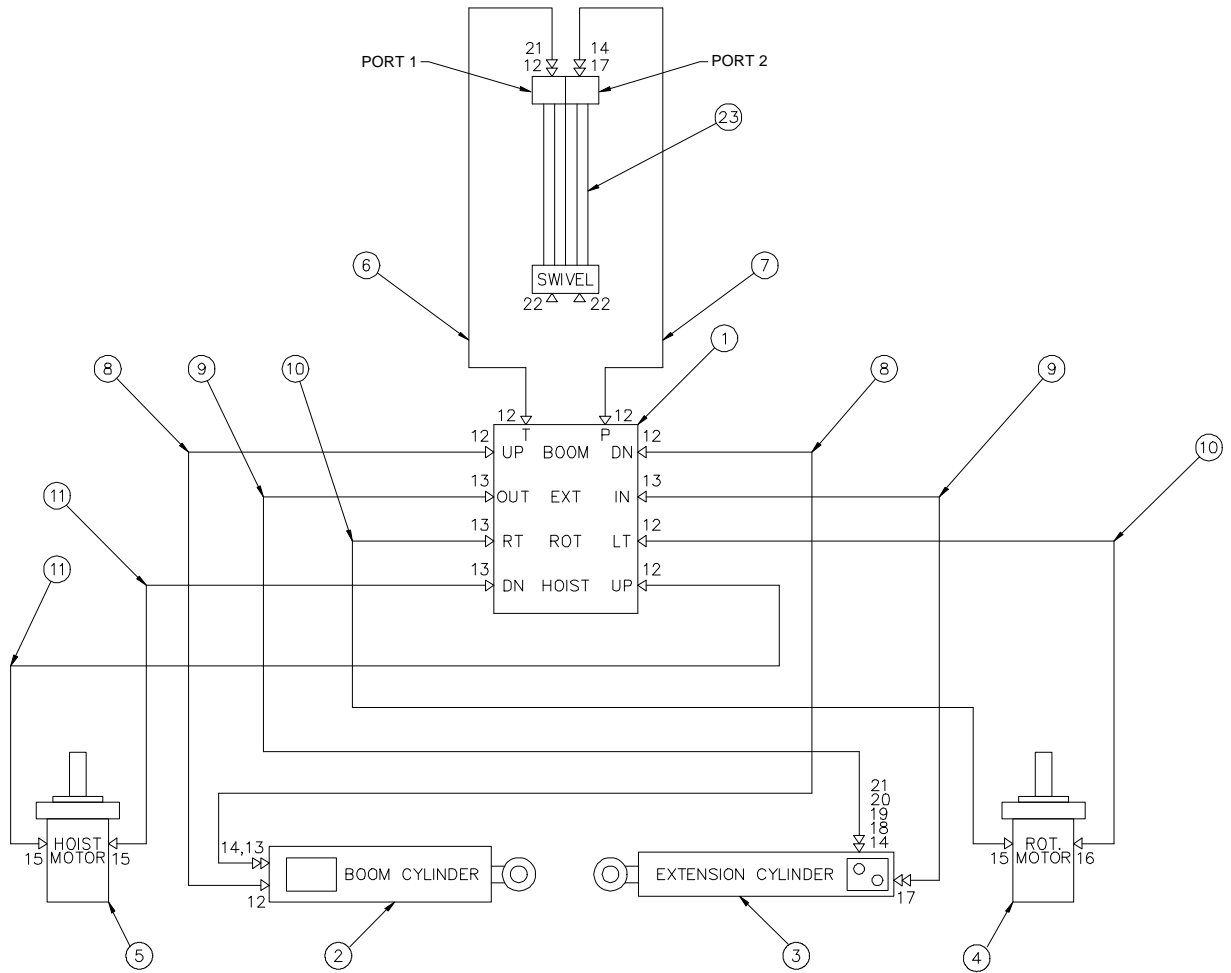

View of Hydraulic Swivel from Bottom of Crane

CAUTION:
Reversing tank and pressure hoses will damage pump.

HYDRAULIC ASSEMBLY

P/N 404089 - MODEL 4004H

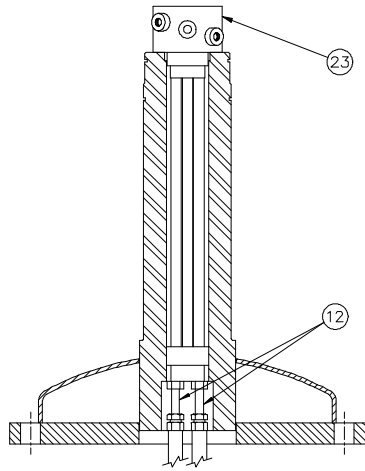

SECTION A-A

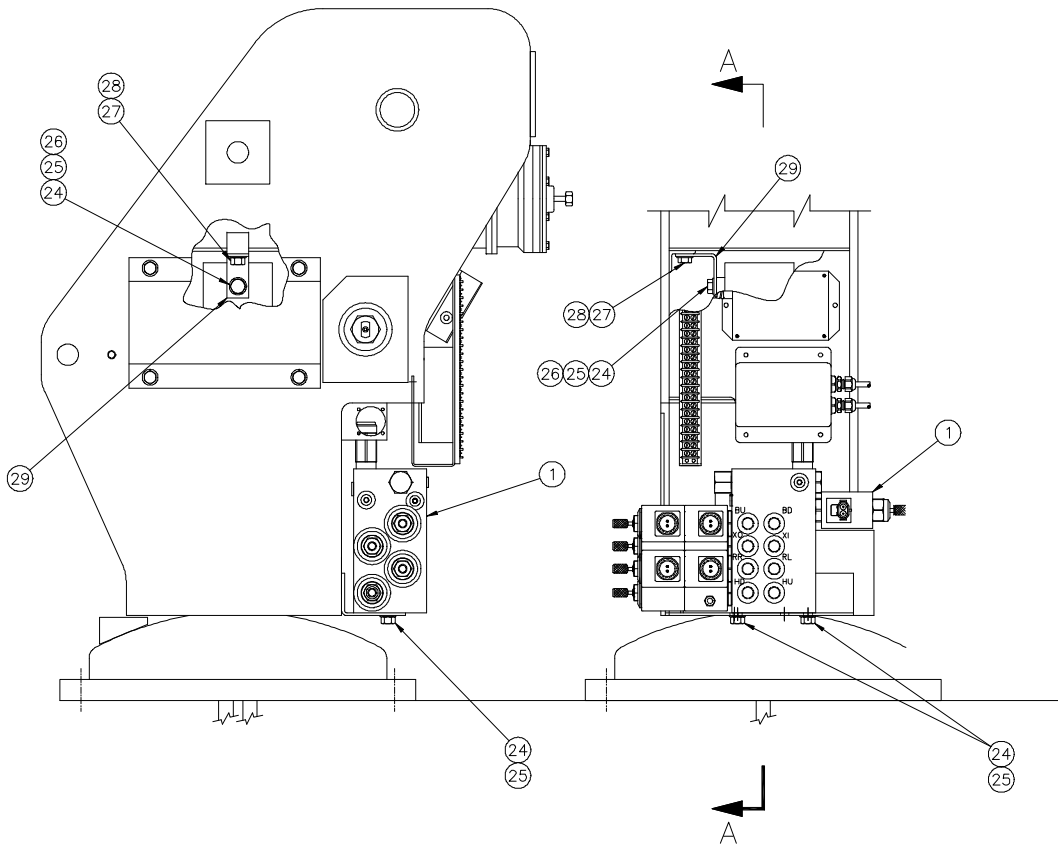
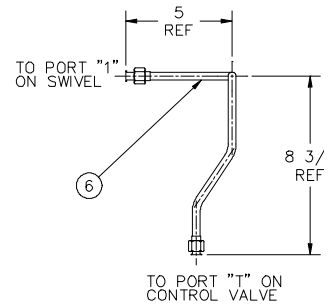
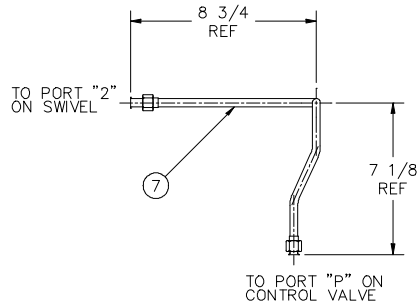

HYDRAULIC ASSEMBLY

P/N 404089 - MODEL 4004H

<u>ITEM</u>	<u>QTY</u>	<u>P/N</u>	<u>DESCRIPTION</u>
1	-	REF	HYDRAULIC MANIFOLD ASSEMBLY (320725)
2	-	REF	CYLINDER BOOM (404005)
3	-	REF	CYLINDER EXTENSION (360152)
4	-	REF	MOTOR ROTATION (320740)
5	-	REF	MOTOR HOIST (320741)
6	1	404108	TUBE ASSEMBLY
7	1	404109	TUBE ASSEMBLY
8	2	812209-036	HOSE ASSEMBLY x 36
9	2	812209-033	HOSE ASSEMBLY x 33
10	1	812209-013	HOSE ASSEMBLY x 13
11	2	812209-029	HOSE ASSEMBLY x 29
12	8	200876	STRAIGHT ADAPTER -6ORM/-6JICM
13	5	373047	STRAIGHT LONG ADAPTER -6OR/-6JICM
14	4	480194	90° ELBOW -6 SWIVEL/-6JIC
15	3	490198	90° ELBOW -10ORM/-6JICM
16	1	372042	90° ELBOW EXTRA LONG -10NPTM/-8JICM
17	3	480195	45° ELBOW -6 OR/-6JIC
18	1	200892	ELBOW 3/8EXT/9/16JIC EXT
19	1	241168	TEE OR/JIC RUN 9/16-18
20	1	480212	TUBE ASSEMBLY EXTENSION
21	1	330647	45° ELBOW SWIVEL -6JIC
22	2	404104	EXTRA LONG ADAPTER -6ORM/-6JICM
23	1	320714	HYDRAULIC SWIVEL
24	3	008400	CAPSCREW 3/8 NC x 3/4
25	4	021100	LOCK WASHER 3/8
26	1	021200	FLAT WASHER 3/8
27	1	008401	HEX HD SCREW 3/8 NC x 1/2
28	1	480188	COUNTERBALANCE CARTRIDGE
29	1	404112	SWIVEL BRACKET
30	1	812210-013	HOSE ASSEMBLY x 13

HYDRAULICS

4004H SERIES

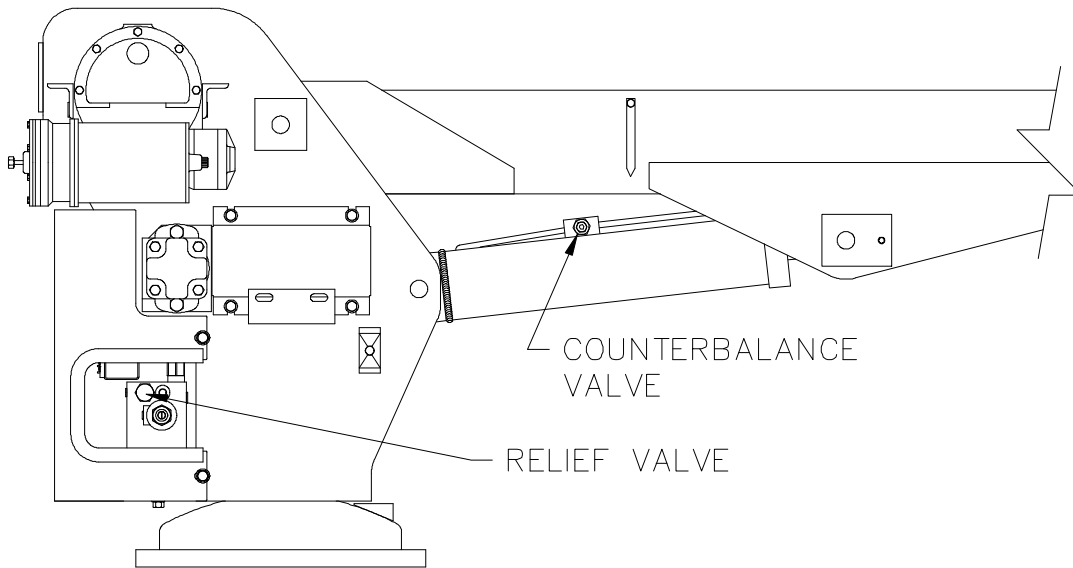

CAUTION:

IF COUNTERBALANCE VALVE IS REPLACED, THE CORRECT PRESSURE SETTING MUST BE MADE BEFORE CRANE IS IN SAFE WORKING CONDITION.

IMPORTANT

Crane boom must be supported and pump system disengaged during the removal and installation of the pressure gage port plug, pressure gage, pressure switch and counterbalance valve.

Valve Setting

To set counterbalance valve:

1. With boom supported, remove -6 ORP plug on cylinder block next to valve and install a pressure gauge; 2500 psi capacity minimum.
2. Boom up until boom cylinder is fully elevated.
3. Boom down in small increments while reading pressure gauge.
4. Loosen the 9/16" nut on end of valve, adjust 5/32" Allen screw and then retighten nut. Repeat procedure until pressure reading is a constant 900 psi. If valve is not set and boom reaches the full down position, boom up and keep trying.
5. Support boom, remove gauge and replace plug when adjustment is complete.

4004H TROUBLESHOOTING GUIDE

1 CRANE FAILS TO OPERATE (ALL FUNCTIONS)

- A. Make sure power switch is set to the "on" position on the pendant.
- B. Check power to crane by checking for truck voltage at terminal #11 on terminal strip. white harness wire.
 - 1. If truck voltage, then go to C.
 - 2. If not check continuity back to battery.
- C. If there is power at terminal #11 and no functions are operable, find proportional valve on the right side of the hydraulic assembly and screw the manual override clockwise to provide flow to manifold. operate a function with the manual override (push or pull).
 - 1. If that function operates properly, then the problem is in the control circuit power wire (pendant or receptacle). Go to D.
 - 2. If that function does not operate properly, go to E.
- D. Electrical problem solutions: pick a specific function and check voltage at the terminal strip by energizing that function using the pendant switch.
 - 1. If voltage is present, then check the ground circuit for continuity.
 - 2. If voltage is not present, then check pendant and harness wiring for a break in the white power wire or the colored function wire.
- E. Hydraulic problem solutions:
 - 1. Make sure the PTO and/or the flow control device(s) are engaged and operable. Noise in pump system or excessive heat in the hydraulic system may indicate a worn or broken pump.

- 2. Check the compensator valve for contamination.

2 HOIST UP, BOOM DOWN, AND EXTEND (OUT) DON'T OPERATE (ALL OTHER FUNCTIONS DO OPERATE). THESE THREE FUNCTIONS ARE TIED INTO THE ANTI-TWO BLOCK AND CRANE OVERLOAD SENSOR SYSTEMS. THE CRANE IS SHUT DOWN WHEN THE SENSORS OPEN THE GROUND CIRCUIT FROM THE FUNCTIONS.

- A. Unplug the anti-two-block system and reconnect din connectors to allow overload system to function (as shown in the manual).
 - 1. If the three functions work, go to B.
 - 2. If the three functions do not work, go to C.
- B. With anti-two-block reconnected, check anti-two-block bail and switch at end of boom to verify they move freely. Switch should make audible click when operated. Try operating crane while pulling cord out of cord reel to check for possible bad spots in cord reel slip rings. Check cord for breaks. A ohmmeter can be used on the two din connectors to test this system while it is unplugged. The system is normally open.
- C. Check load sensor pressure switch by unplugging the din connector and checking for a closed circuit.
 - 1. If circuit is closed and boom is unloaded, replace switch and reconnect anti-two-block circuit.

CAUTION: BE SURE BOOM IS SUPPORTED BEFORE REMOVING SWITCH OR BOOM WILL FALL.

- 2. If circuit is open, go to D.

4004H TROUBLESHOOTING GUIDE

D. Locate timing relay box on back of crane and open lid. Disconnect yellow wire on terminal #1 of the time delay relay.

1. If the three functions do not work, check the ground for overload system through the relay. (The relay may be operated by touching the yellow wire to any ground.)
2. If three functions work, clean terminals #6 and #7 on time delay relay, reconnect yellow wire to #1 terminal and retry the three functions.
 - i. If the three functions still do not work, replace the time delay relay.
 - ii. If the three functions work, spray the terminals with a protective coating and keep them clean.
3. The time delay relay may be operated by removing the connectors from terminals #6 and #7 and shorting the two terminals with a jumper. The interval between make and brake is approximately $\frac{3}{4}$ second.

CAUTION: CONNECTING THE POWER TERMINAL #3 TO TERMINAL #6 MAY CAUSE RELAY FAILURE.

3 SINGLE HYDRAULIC FUNCTION DOES NOT WORK.

A. With trigger pulled, operate the function using the manual override.

1. If it works, check power and ground going to coil at weather pack connector.

- i. Verify ground circuit.
- ii. Verify function power circuit.

2. If it does not work, then remove valve, clean and inspect it.

3. If it still does not work, then check cylinder or motor and connecting hoses for obstructions or failure.

B. Test the proportional activation system also by operating the proportional manual override screw instead of the trigger on the pendant. *Be sure to restore the override to the full out position before using the crane.*

C. If boom retract or boom down functions don't work, then check for low hydraulic pressure at pump. These two functions have the highest pressure requirements for an unloaded crane because they must overcome the pressure settings of the counter balance valves.

D. If hydraulic functions are more intermittent when cylinders are extended, then check hydraulic fluid level.

E. Boom locks up and won't come down when fully raised-this is caused by having the pump relief pressure higher than the pressure that causes the overload system to activate. Set relief pressure to the correct setting of 2200 psi. Unlock boom by using the manual override of the boom down function. If pressure is correct and problem continues, then replace overload pressure switch.

HYDRAULIC DIRECT MOUNT PUMP

P/N 360029 - 4004H SERIES

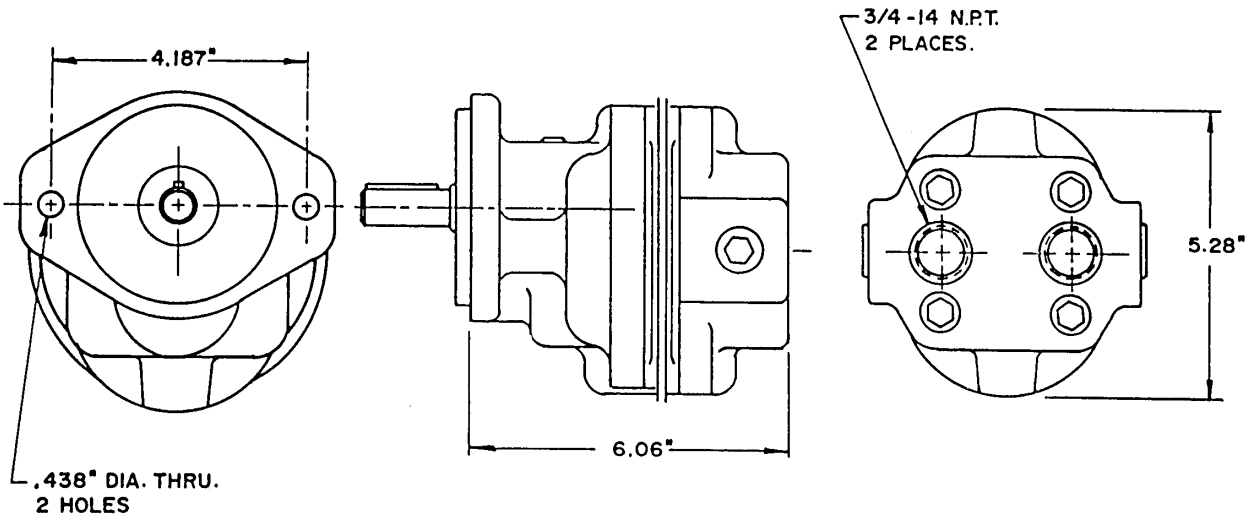

Adapter: SAE "A" 2 bolt flange (direct mount only).
Shaft: Straight shaft key 3/4 dia. x 2 3/4 long.
3/16 sq. key x 1 5/8 long.

NOTES:

1. Pump speed - 800 RPM for 4004H and 950 RPM for 5005H.
2. To order **HYDRAULIC PUMP ASSEMBLY** use **P/N 360030** - which consists of HYDRAULIC PUMP (P/N 360029), 3/4-14NPT/1-5/16-12 JIC ADAPTER (P/N 360055) SUCTION AND 3/4-14 NPT/ 1 1/16-12 JIC (750399) PRESSURE.
3. For **SEAL KIT** use **P/N 480018-001**.
4. For **SERVICE KIT** use **P/N 480018-002**.

LOAD CHART 10-16-20

P/N 404121 - 4004H SERIES

MODEL 4004H 10-16-20 MAXIMUM LOAD CHART

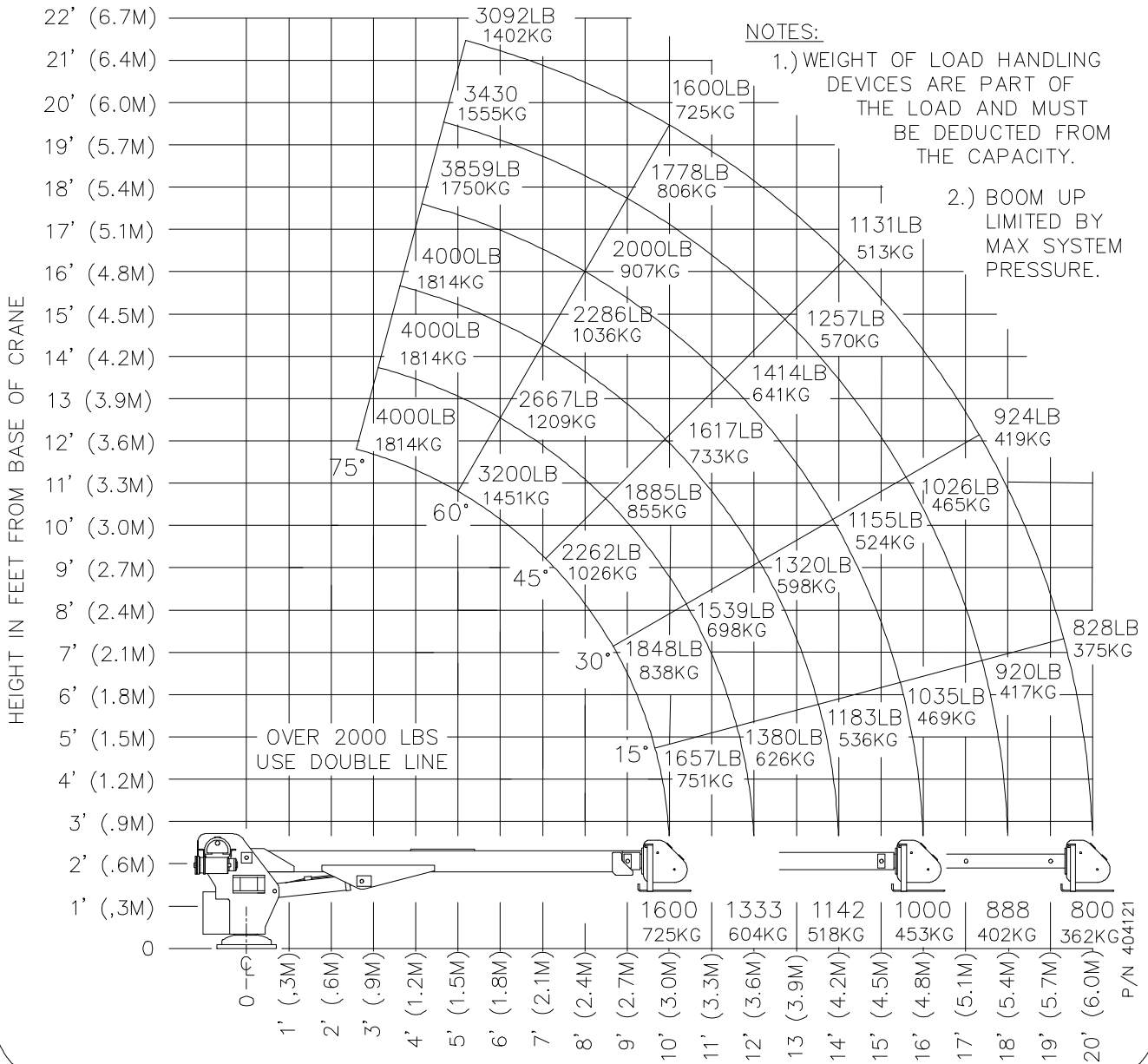

LOAD CHART 10-16

P/N 404120 - 4004H SERIES

MODEL 4004H 10-16 MAXIMUM LOAD CHART

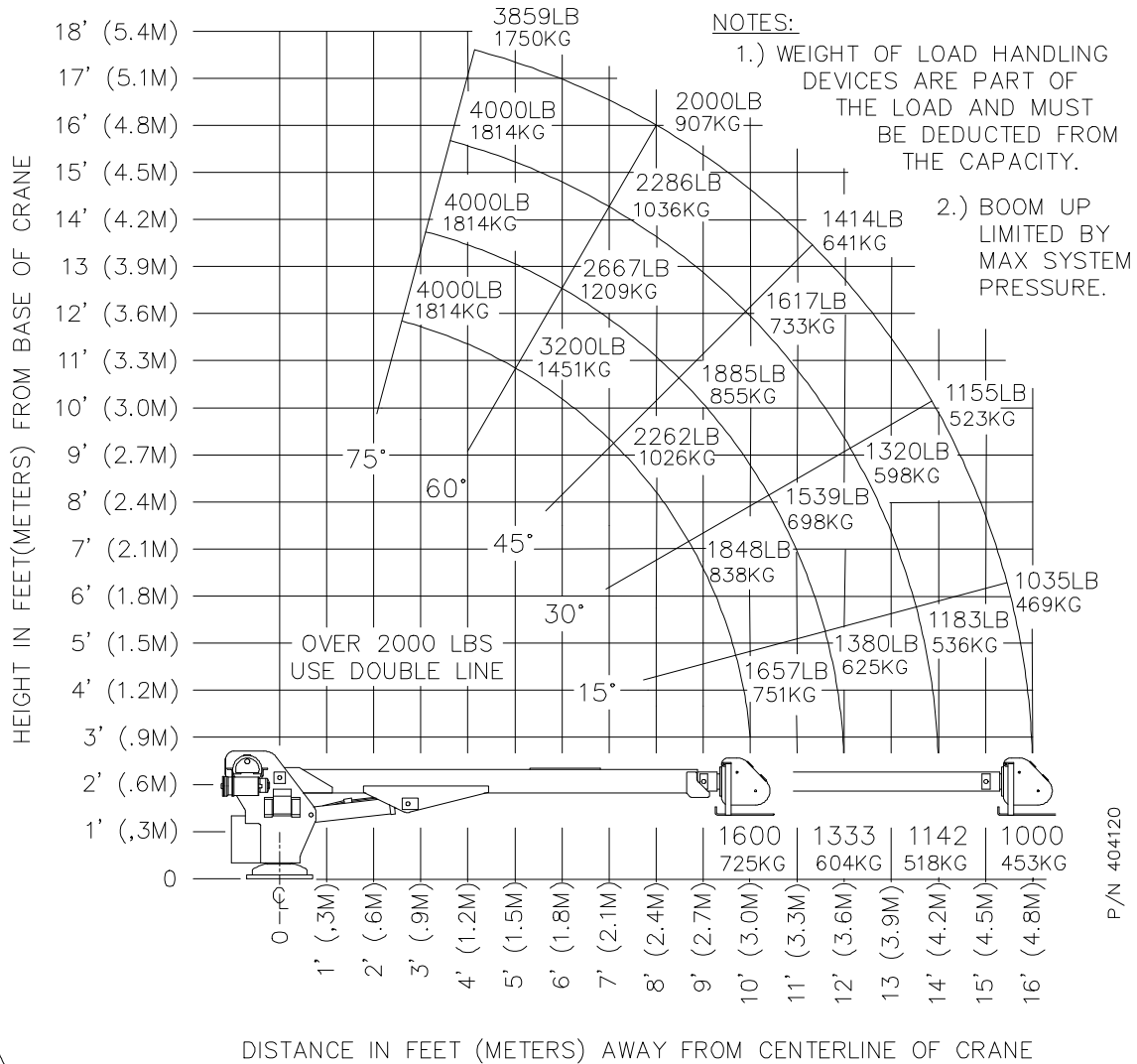

P/N 404120



AUTO CRANE COMPANY

P. O. BOX 581510 • TULSA, OKLAHOMA 74158

Limited Warranty

Auto Crane will warranty to consumer for a period of twelve months from date of purchase that each new Auto Crane product it sells will be free under normal use and service, from defects in material and workmanship. Date of purchase will be honored as either date of purchase by distributor or his date of sale of the product as substantiated by Distributor Delivery Report.

Obligation of Auto Crane under this warranty is limited to replacement or repair of parts that appear to manufacturer after review and / or inspection to be defective. This warranty does not obligate Auto Crane to bear the cost of labor or transportation charges in connection with the replacement or repair of defective parts. Responsibility for customer's claims arising from misapplication, abuse, misuse or alteration of equipment or parts lies with the distributor or user and no warranty obligation is assumed in the circumstances by Auto Crane.

Auto Crane will in no event be liable for any consequential damages or contingent liabilities arising out of the failure of any Auto Crane product or parts to operate properly.

Auto Crane makes no warranty in respect to component accessories, same being subject to the warranties of their respective manufacturers.

If field service, at the request of buyer, is rendered and fault is found not to be with Auto Crane's product, the buyer shall pay the time and expense of the field representative. Claims for service labor or other expenses that have been incurred by the buyer without approval or authorization of Auto Crane will not be accepted.

AUTO CRANE COMPANY IS UNDER NO OBLIGATION TO EXTEND THIS WARRANTY TO ANY CUSTOMER FOR WHICH AN AUTO CRANE WARRANTY REGISTRATION CARD HAS NOT BEEN COMPLETED AND MAILED TO AUTO CRANE COMPANY WITHIN FIFTEEN (15) DAYS AFTER DATE OF PURCHASE.