

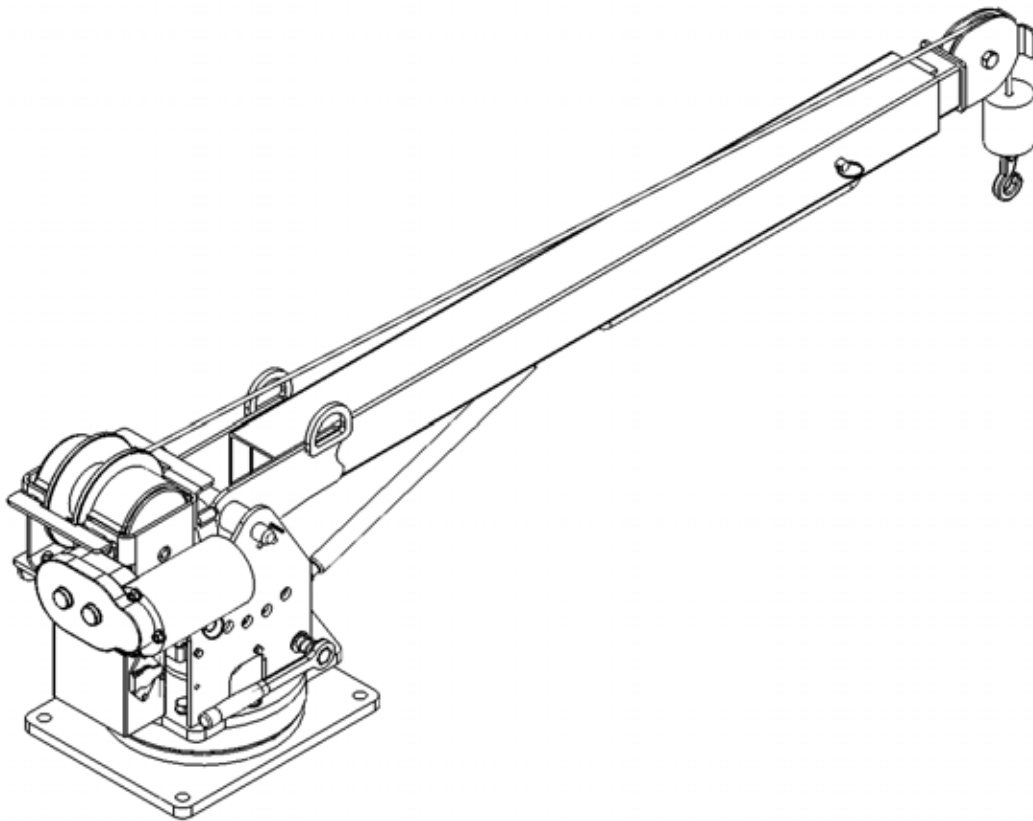

2003 OWNERS MANUAL

Manual No. 999951000
Rev. 3/15/07



Serial No. _____

Mailing Address:
P.O. Box 580697
Tulsa, OK 74158-0697
Physical Address:
4707 N. Mingo Rd.
Tulsa, OK 74117-5904

Phone (918) 836-0463
Fax (918) 834-5979
<http://www.autocrane.com>



Auto Crane Warranty Registration

Fax Transmission

To: Warranty Department Fax: (918) 834-5979
 From: _____ Date: _____
 Re: Product Registration Pages: _____

End User Information: (Required for Warranty Activation)

Name: _____ Phone: _____
 Address: _____
 City: _____ State: _____ Zip: _____
 Contact: _____ E-mail Address: _____

Distributor Information: (Required for Warranty Activation)

Name: _____
 Address: _____
 City: _____ State: _____ Zip: _____
 Contact: _____ E-mail Address: _____

Product Information: (Required for Warranty Activation)

Model No.: _____ Serial No.: _____
 Date Product Delivered: _____ Date Processed:* _____
 VIN # _____ * For Auto Crane use only

ONE REGISTRATION FORM PER UNIT (CRANE OR BODY)

Registration form must be mailed or faxed within 15 days of customer installation.

Mail to:
 Warranty Department
 Auto Crane Company
 P.O. Box 581510
 Tulsa, OK 74158-0697

2003 OWNER'S MANUAL REVISION RECORD

Revision Date	Section(s) Or Page(s)	Description of Change
09/02/03	Last page	New 2-year warranty policy to replace 1-year warranty policy
3/15/07	All	General revisions – Crane Redesign

Notes:

1. The information contained in this manual is in effect at the time of this printing. It does not cover all instructions, configurations, accessories, etc. If you require additional information, please contact **Auto Crane Company** at **(918) 836-0463**.
2. **Auto Crane Company** reserves the right to update this material without notice or obligation.

WARNINGS

WARNING! Federal law (49 cfr part 571) requires that the Final Stage Manufacturer of a vehicle certify that the vehicle complies with all applicable federal regulations. Any modifications performed on the vehicle prior to the final state are also considered intermediate stage manufacturing and must be certified as to compliance. The installer of this crane and body is considered one of the manufacturers of the vehicle. As such a manufacturer, the installer is responsible for compliance with all applicable federal and state regulations, and is required to certify that the vehicle is in compliance.

WARNING! It is the further responsibility of the installer to comply with the OSHA Truck Crane Stability Requirements as specified by 29 CFR part 1910.180 (C) (1).

WARNING! NEVER OPERATE THE CRANE NEAR ELECTRICAL POWER LINES!

Death or serious injury will result from boom, line, or load contacting electric lines. Do not use crane within 10 feet (3.05m) of electric power lines carrying up to 50,000 volts. One-foot additional clearance is required for every additional 30,000 volts or less. **SEE DANGER DECAL (P/N 040529)** in this Owner's Manual.

WARNING! NEVER.....

- ◆ **EXCEED** load chart capacities (centerline of rotation to hoist hook).
- ◆ Un-reel last 5 wraps of cable from drum!
- ◆ Wrap cable around load!
- ◆ Attempt to lift or drag a load from the side! The boom can fail far below its rated capacity.
- ◆ Weld, modify, or use unauthorized components on any Auto Crane unit! This will void any warranty or liability. Also failure of the crane may result.
- ◆ Place a chain link on the tip of the hook and try to lift a load!
- ◆ Use a sling bar or anything larger than the hook throat that could prevent the hook latch from closing, thus negating the safety feature!
- ◆ Hold on any pendant Select Switch that will cause unsafe operating conditions!

WARNING! In using a hook with latch, **ALWAYS** make sure that the hook throat is closed before lifting a load! Proper attention and common sense applied to the use of the hoist hook and various slings will prevent possible damage to material being hoisted and may prevent injury to personnel.

WARNING! Failure to correctly plumb and wire crane can cause inadvertent operation and damage to crane and/or personnel!

WARNING! Auto Crane Company remote controlled cranes are not designed or intended for use for any applications involving the lifting or moving of personnel.

WARNING! ALWAYS operate the crane in compliance with the load capacity chart. **DO NOT USE** the overload shutdown device to determine maximum rated loads, if the crane is equipped with this type of device.

READ THIS PAGE

2003

TABLE OF CONTENTS

INTRODUCTION	1-1.0
GENERAL SPECIFICATIONS	1-3.0
SAFETY TIPS AND PRECAUTIONS	2-1.0
OPERATING PRACTICES & WARNINGS	2-3.0
QUALIFICATIONS FOR OPERATORS	2-4.0
OPERATION OF UNIT / OUTRIGGERS	2-7.0
INSPECTION	3-1.0
TESTING	3-4.0
MAINTENANCE	3-5.0
BATTERIES	3-7.0
LUBRICATION AND MAINTENANCE SCHEDULE	3-9.0
SAFETY DECAL SECTION	4-1.0
GENERAL DIMENSIONS	5-1.0
MOUNTING AND INSTALLATION	5-2.0
OPERATING INSTRUCTIONS	5-3.0
GENERAL ASSEMBLY	6-1.0
HOIST ASSEMBLY	6-5.0
HOIST ACTUATOR	6-6.0
PENDANT ASSEMBLY	7-1.0
RELAY PANEL ASSEMBLY	7-2.0
WIRING DIAGRAM	7-4.0
ELECTRICAL SCHEMATIC	7-5.0
LOAD CHART	8-1.0
WARRANTY	LAST PAGE

2003 INTRODUCTION

Auto Crane products are designed to provide many years of safe, trouble-free, dependable service when properly used and maintained.

To assist you in obtaining the best service from your crane and to avoid untimely crane and/or vehicle failure, this manual provides the following operating and service instructions. It is specifically recommended that all operating and service personnel consider this manual as mandatory material for reading and study before operating or servicing Auto Crane products. It is highly recommended that crane owners, equipment managers, and supervisors also read this manual.

Auto Crane has incorporated several safety features in the 2003 crane for your protection.

For your convenience the overall dimensions of the 2003 crane are included on the General Dimension Drawing. Rotation and turning radius are also listed on that drawing.

Remember, the crane adds weight to the vehicle. Adding weight may change the driving and riding characteristics of the vehicle unless the appropriate overload spring(s) are installed on the truck. The payload of the vehicle is reduced by the weight of the crane. The operator should exercise care when loading the vehicle. Distributing the payload on the vehicle evenly will greatly improve the driving and riding characteristics of the vehicle.

Auto Crane Company issues a limited warranty certificate with each unit sold. See last page for warranty.

The 2003 cranes are attached to your truck electrical system through the Main Power Switch provided. The 2003 is another highly efficient Auto Crane product. The use of a maintenance-free battery is not recommended on any Auto Crane product. The recommended alternator and battery

that will give the longest life with the most useful duty cycle is a 75-amp alternator with a 500 cold cranking amp battery. These specifications should be considered minimum.

It has always been Auto Crane Company policy to handle all warranty claims we receive as promptly as possible. If a warranty claim involves discrepant material or workmanship, Auto Crane will take immediate corrective action. It is understandable that Auto Crane Company cannot assume responsibility of liability when it is obvious that our products have been abused, misused, overloaded or otherwise damaged by inexperienced persons trying to operate the equipment without reading the manual.

Auto Crane will not assume responsibility or liability for any modifications or changes made to unit, or installation of component parts without authorization.

Auto Crane maintains a strong distributor network and a knowledgeable Customer Service Department. In most cases, an equipment problem is solved via phone conversation with our customer service department. The customer service department also has the ability to bring a local distributor, a regional sales manager, or a factory serviceman into the solution of an equipment problem.

If, through no fault of Auto Crane Company, it is necessary to send an experienced factory serviceman on a field service call the rates stated in the Auto Crane Distributor's Flat Rate Manual will apply.

Auto Crane Company's extensive Research and Development Program allow our customers to use the best equipment on the market. Our Engineering Staff and our knowledgeable sales people are always available to our customers in solving crane and winch-type application problems. When in doubt, call the Auto Crane factory.

Note: This manual should remain with the crane at all times.

2003 INTRODUCTION

DISTRIBUTOR ASSISTANCE:

Should you require any assistance not given in this manual, we recommend that you consult your nearest Auto Crane Distributor. Our distributors sell authorized parts and have service departments that can solve almost any needed repair. This manual does not cover all maintenance, operating, or repair instructions pertinent to all possible situations. **If you require additional information, please contact the Auto Crane Company at the following telephone number: (918) 836-0463.** The information contained in the manual is in effect at the time of this printing. Auto Crane Company reserves the right to update this material without notice or obligation.

2003 GENERAL SPECIFICATIONS

DIMENSIONS

Width: 18.43 in (0.47 m)
Height: 23.60 in (0.60 m)
Length: 6 ft 10.56 in (2.10 m)
 [boom(s) stored]
Weight: 346 lbs (157 kg)

REACH

Second boom will reaches to 5 feet 7 inches, 7 feet 3 inches and 9 feet 3 inches.

CABLE

50 ft (15.2 m) of 1/4 in (6.35 mm) diameter aircraft quality cable. This cable has a single line breaking strength of 7,000lbs (3,175 kg).

CAPACITY

6,000 ft-lbs (.8 ton-m)
 [ft-lbs = horizontal distance from centerline of rotation to free hanging weight (feet) x amount of weight (pounds)]

CHASSIS REQUIREMENTS

8,000 lbs (3,628 kg) GVWR minimum

LIFTING CAPACITIES	
ft	lbs
2	2,000
3	2,000
4	1,500
5	1,200
6	1,000
7	855
8	750
9	665

ELECTRICAL SYSTEM REQUIREMENTS

Voltage: 12 VDC
Alternator: 75 amp (minimum)
Battery: 100 minute reserve capacity (minimum)
 Maintenance type

ROTATION

360° continuous manual rotation

--- IMPORTANT ---

SAFETY TIPS AND PRECAUTIONS

1. No unqualified or unauthorized person shall be allowed to operate the crane.
2. **WARNING:** Never weld, modify, or use unauthorized components / parts on any Auto Crane unit. This will void any warranty or liability. Also, failure of the crane may result.
3. Make certain the vehicle meets minimum chassis requirements. (These requirements do not guarantee unit stability.)
4. Make certain the crane is installed per factory specifications. Contact your local distributor or the Auto Crane factory if any questions arise.
5. Visual inspections and tests should be conducted at the beginning of each shift each day to insure that the crane and all its operating systems are in good condition and working order before it is used.
6. Inspect hydraulic hoses frequently for signs of deterioration, and replace them as required.
7. If a hydraulic break occurs, leave the area of the break and do not attempt to stop the break by hand as the hydraulic oil may be hot and under high pressure which can cause serious injury. Shut the system down as soon as possible.
8. Check the hook at least every thirty days for distortions or cracks and replace it as required.
9. Oil gears as required.
10. Stop all operations when cleaning, adjusting or lubricating the machine.
11. Keep dirt and grit out of moving parts by keeping crane clean. Make sure machine is free of excess oil, grease, mud and rubbish, thus reducing accidents and fire hazards.
12. When a new cable is installed, operate first with a light load to let the cable adjust itself.
13. Locate the vehicle at the work site for the best stability possible.
14. Keep the vehicle in a level position while loading or unloading.
15. Observe operating area for obstructions and/or power lines that might be a hazard.
16. **WARNING: NEVER OPERATE THE CRANE NEAR ELECTRICAL POWER LINES.** Auto Crane Company recommends that the crane never be any closer to a power line (including telephone lines) than 10 feet at any point.
17. Allow the vehicle engine to warm up before operating crane.
18. Know the weight of your rigging and load to avoid overloading the crane.
19. Deduct the weight of the load handling equipment from the load rating to determine how much weight can be lifted.
20. All load ratings are based on crane capacity, NOT the vehicle stability. Remember in lifting a heavy load, the weight can create enough tipping moment to overturn the vehicle
21. Always comply with load chart capacities, (centerline of rotation to hook).
22. Secure all loads before lifting.
23. Always set the emergency brake before beginning operation.
24. Keep objects and personnel clear of crane path during operation.
25. Operate control levers slowly and smoothly in order to meter oil flow for safe operation. (Not applicable to electric-hydraulic cranes.)
26. Always extend the outriggers from vehicle to the ground before crane operation. Insure that they are firmly positioned on solid footings. Stand clear of outriggers while they are being extended.
27. If any outrigger, when extended, rests on a curb or other object that prevents it from extending to its maximum distance, shorten bearing or fulcrum point and reduce the maximum load accordingly.
28. When an outrigger will not reach the ground due to holes or grades, it shall be blocked up to provide level and firm support for the truck.
29. When working in soft earth, use wide pads under outrigger feet to prevent sinking.
30. Always store outriggers before transportation.

WARNING!

Auto Crane Company cranes are not designed or intended for use in lifting or moving persons. Any such use shall be considered to be improper and the seller shall not be responsible for any claims arising there from. This sale is made with the express understanding that there is no warranty that the goods shall be fit for the purpose of lifting or moving persons or other improper use and there is no implied warranty or responsibility for such purposes.

--- IMPORTANT ---

SAFETY TIPS AND PRECAUTIONS

31. Always store the crane in its stowed position for transportation.
32. Remember the overall height of the entire unit for garage door clearance or when moving under objects with low overhead clearance
33. Disengage power takeoff (PTO) before moving the vehicle.
(Not applicable to electric-hydraulic cranes.)
34. Always walk around the vehicle before moving.
35. Never drive with a load suspended from crane.
36. Do not take your eyes off a moving load. Look in the direction you are moving.
37. Never swing a load over people.
38. Do not stop the load sharply in midair so that it swings like a pendulum. Meter the control levers to avoid this situation.
(Not applicable to electric-hydraulic cranes.)
39. Crane boom length should be kept as short as possible for maximum lifting capacity and greater safety. Longer booms require additional care in accelerating and decelerating the swing motion, and thus slow down the working cycle and reduce productivity.
40. Keep the load directly and vertically under the boom point at all times. Crane booms are designed to handle vertical loads, not side lifts.
- WARNING:** Never attempt to lift, drag, tow or pull a load from the side. The boom can fail far below its rated capacity.
41. Do not push down on anything with boom extensions; similarly do not lift anything with boom extensions.
42. Do not lift personnel with any wire rope attachment or hook. There is no implied warranty or responsibility for such purposes.
43. **WARNING:** In using a safety hook, ALWAYS close the hook throat before lifting a load. Proper attention and common sense applied to the use of the hook and various slings will prevent possible damage to material being hoisted and may prevent injury to personnel.
44. **WARNING:** Never place a chain link on the tip of the hook and try to lift a load with the hoist.
45. **WARNING:** Never use a sling bar or anything larger than the hook throat which could prevent the safety latch from closing, thus negating the safety feature.
46. Do not wrap the wire rope around sharp objects when using winch.
47. **WARNING:** Never unreel last 5 wraps of cable from drum.

--- IMPORTANT --- OPERATING PRACTICES AND WARNINGS

1. Make certain the vehicle meets minimum chassis requirements. (These requirements do not guarantee unit stability)
2. Make certain the crane is installed per factory specifications. Contact your local Distributor or the Auto Crane factory if any questions arise.
3. Keep the vehicle in as level a position as possible while loading or unloading.
4. **ALWAYS** set the vehicle emergency brake before beginning crane operations.
5. **ALWAYS** use outriggers from vehicle to the ground during crane operation. Make sure they are firmly positioned on solid footings.
6. All load ratings are based on crane capacity, **NOT** truck/crane stability.
7. Keep objects and personnel clear of crane path during operation.
8. Keep hoist cable pulled tight at all times.
9. **REMEMBER**, in lifting a heavy load, the weight can create enough tipping momentum to overturn the vehicle.
10. **ALWAYS** keep load as close to ground as possible.
11. Hydraulic hoses need to be inspected frequently for signs of deterioration, and be replaced as required.
12. The hoist hook is an important item that an operator should consider and use properly. It should be checked on a daily basis for distortion or cracks.
13. **ALWAYS** store outriggers before road travel.
14. **WARNING! NEVER OPERATE THE CRANE NEAR ELECTRICAL POWER LINES!** Death or serious injury will result from boom, line, or load contacting electric lines. Do not use crane within 10 feet (3.05m) of electric power lines carrying up to 50,000 volts. One foot additional clearance is required for every additional 30,000 volts or less.
15. **WARNING! NEVER EXCEED** load chart capacities (centerline of rotation to hoist hook).
16. **WARNING! NEVER** un-reel last 5 wraps of cable from drum!
17. **WARNING! NEVER** wrap cable around load!
18. **WARNING! NEVER** attempt to lift or drag a load from the side! The boom can fail far below its rated capacity.
19. **WARNING! NEVER** weld, modify, or use unauthorized components on any Auto Crane unit! This will void any warranty or liability. Also failure of the crane may result.
20. **WARNING! NEVER** place a chain link on the tip of the hook and try to lift a load!
21. **WARNING! NEVER** use a sling bar or anything larger than the hook throat that could prevent the hook latch from closing, thus negating the safety feature!
22. **WARNING!** In using a hook with latch, **ALWAYS** insure that the hook throat is closed before lifting a load! Proper attention and common sense applied to the use of the hoist hook and various slings will prevent possible damage to material being hoisted and may prevent injury to personnel.
WARNING! NEVER hold any Control Select Switch on that will cause unsafe operating conditions!

WARNING!

Auto Crane Company remote controlled, stiff boom cranes are not designed or intended for use on any applications involving the lifting or moving of personnel.

QUALIFICATIONS FOR AND CONDUCT OF OPERATORS AND OPERATING PRACTICES

REFERENCE ASME B30.5a AND OSHA 1910.180 FOR COMPLETE QUALIFICATION REQUIREMENTS

OPERATORS

1. Crane operation shall be limited to personnel with the following minimum qualifications:
 - A. Designated persons.
 - B. Trainees under the direct supervision of a designated person.
 - C. Maintenance and test personnel (when it is necessary in the performance of their duties).
 - D. Inspectors (crane).
2. No one other than the personnel specified above shall enter the operating area of a crane with the exception of persons such as oilers, supervisors, and those specified persons authorized by supervisors whose duties require them to do so and then only in the performance of their duties and with the knowledge of the operator or other persons.

QUALIFICATIONS FOR OPERATORS

1. Operators shall be required by the employer to pass a practical operating examination. Qualifications shall be limited to the specific type of equipment for which examined.
2. Operators and operator trainees shall meet the following physical qualifications:
 - A. Vision of at least 20/30 Snellen in one eye and 20/50 in the other, with or without corrective lenses.
 - B. Ability to distinguish colors, regardless of position, if color differentiation is required for operation.
 - C. Adequate hearing with or without hearing aid for the specific operation.
3. Evidence of physical defects or emotional instability, which render a hazard to operator or others, which in the opinion of the examiner could interfere with the operator's performance, may be sufficient cause for disqualification. In such cases, specialized clinical or medical judgment and tests may be required.
4. Evidence that operator is subject to seizures or loss of physical control shall be sufficient reason for disqualification. Specialized medical

tests may be required to determine these conditions.

5. Operators and operator trainees should have normal depth perception, coordination, and no tendencies to dizziness or similar undesirable characteristics.
6. In addition to the above listed requirements, the operator shall:
 - A. Demonstrate the ability to comprehend and interpret all labels, operator's manuals, safety codes, and other information pertinent to correct crane operations.
 - B. Posses the knowledge of emergency procedures and implement it.
 - C. Demonstrate to the employer the ability to operate the specific type of equipment.
 - D. Be familiar with the applicable safety regulations.
 - E. Understand the operating procedures as outlined by the manufacturer.
 - F. Be thoroughly familiar with the crane and its control functions.
 - G. Understand the operating procedures as outlined by the manufacturer.

CONDUCT OF OPERATORS

1. The operator shall not engage in any practice, which will divert his attention while actually operating the crane.
2. Each operator shall be responsible for those operations under the operator's direct control. Whenever there is any doubt as to safety, the operator shall consult with the supervisor before handling the loads.
3. The operator should not leave a suspended load unattended unless specific precautions have been instituted and are in place.
4. If there is a warning sign on the switch or engine starting controls, the operator shall not close the switch or start the engine until the warning sign has been removed by the appointed person.
5. Before closing the switch or starting the engine, the operator shall see that all controls are in the "OFF"

QUALIFICATIONS FOR AND CONDUCT OF OPERATORS AND OPERATING PRACTICES

- or neutral position and all personnel are in the clear.
6. If power fails during operation, the operator shall:
 - A. Move power controls to the "OFF" or neutral position.
 - B. Land the suspended load and boom, if practical.
 7. The operator shall be familiar with the equipment and its proper care. If adjustments or repairs are necessary, the operator shall report the same promptly to the appointed person, and shall also notify the next operator.
 8. The operator at the start of each shift shall test all controls. If any controls do not operate properly, they shall be adjusted or repaired before operations are begun.
 9. Stabilizers shall be visible to the operator while extending or setting unless a signal person assists operator.
- C. Means are provided to hold the vehicle stationary while operating the crane.
 - D. Before starting to lift, the hook shall be positioned over the load in such a manner as to minimize swinging.
 - E. During lifting care shall be taken that:
 1. There is no sudden acceleration or deceleration of the moving load.
 2. Load, boom or other parts of the crane do not contact any obstruction.
 - F. Cranes shall not be used for dragging loads sideways.
 - G. This standard recognizes that telescopic boom cranes are designed and intended for handling materials. They do not meet personnel lift or elevator requirements. Therefore, no lifting, lowering, swinging or traveling shall be done while a person is on the hook or load. Hook attached suspended work platforms (baskets) shall not be used with cranes covered by this standard. Crane manufacturer must approve work platforms attached to the boom.
 - H. The operator should avoid carrying loads over people.
 - I. When the crane is so equipped, the stabilizers shall be fully extended and set. Blocking under stabilizers shall meet the requirements as follows:
 1. Strong enough to prevent crushing.
 2. Of such thickness, width and length as to completely support the stabilizer pad.
 - J. Firm footing under all tires, or individual stabilizer pads should be level. Where such a footing is not otherwise supplied, timbers, cribbing, or other structural members to distribute the load so as to not exceed allowable bearing capacity or the underlying material should provide it.
 - K. In transit, the boom shall be carried in stowed position.
 - L. When rotating the crane, sudden starts and stops shall be avoided. Rotational speed shall be such that the load does not swing out beyond the radius at which it can be controlled.
 - M. The crane shall not be transported with a load on the hook unless recommended by the manufacturer.

OPERATING PRACTICES/HANDLING THE LOAD

1. Size of load.
 - A. No crane shall be loaded beyond the rated load except for test purposes.
 - B. The load to be lifted is to be within the rated load of the crane and its existing configuration.
 - C. When loads that are not accurately known are to be lifted, the person responsible for the job shall ascertain that the weight of the load does not exceed the crane rated load at the radius at which the load is to be lifted.
2. Attaching the load.
 - A. The load shall be attached to the hook by means of slings or other devices of sufficient capacity.
 - B. Hoist rope shall not be wrapped around the load.
3. Moving the load.

The operator shall determine that:

 - A. The crane is level and, where necessary, the vehicle/carrier is blocked properly.
 - B. The load is well secured and balanced in the sling or lifting device before it is lifted more than a few inches.

QUALIFICATIONS FOR AND CONDUCT OF OPERATORS AND OPERATING PRACTICES

N. No person should be permitted to stand or pass under a suspended load.

4. Stowing procedure.

Follow the manufacturer's procedure and sequence when stowing and un-stowing the crane.

3. Caution shall be exercised when working near overhead lines, because they can move horizontally or vertically due to wind, moving the danger zone to new positions.

4. In transit with no load and boom lowered the clearance shall be specified in Table 1.

5. A qualified signalperson shall be assigned to observe the clearance and give warning before approaching the above limits.

MISCELLANEOUS

OPERATING NEAR ELECTRICAL POWER LINES

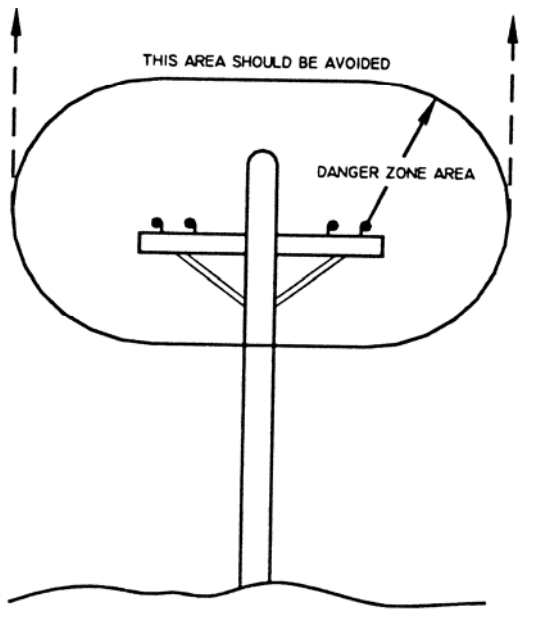

1. Cranes shall be operated so that no part of the crane or load enters into the danger zone shown above.

EXCEPTIONS

A. The danger zone may be entered after confirmation by an appointed person that the electrical distribution and transmission lines have been de-energized and visibly grounded at the point of work; or

B. The danger zone may be entered if insulating barriers (not a part of nor an attachment to the crane) have been erected to prevent physical contact with the lines.

2. For lines rated 50 kV or below, minimum clearance between the lines and any part of the crane or load (including handling appendages) shall be 10-ft. (3m). For higher voltages, see Table 1.

A. Any overhead wire shall be considered to be an energized line unless and until the person owning such line or the electrical utility authorities verify that it is not an energized line.

B. Exceptions to this procedure are allowed, if approved by the administrative or regulatory authority provided the alternate procedure insures equivalent protection and is set forth in writing.

C. Durable signs shall be installed at the operator's station and on the outside of the crane, warning that electrocution or serious bodily injury may occur unless a minimum clearance of 10 ft. (3.0m) between the crane or the load being handled and energized power lines. Greater clearances are required because of higher voltage as stated above. These signs shall be revised but not removed when local jurisdiction requires greater clearances.

TABLE 1

		minimum required clearance	
normal voltage, kV (phase to phase)		ft	(m)
<u>when operating near high voltage power lines</u>			
over	to 50	10	(3.50)
over	50 to 200	15	(4.6)
over	200 to 350	20	(6.1)
over	350 to 500	25	(7.62)
over	500 to 750	35	(10.67)
over	750 to 1000	45	(13.72)
<u>while in transit with no load and boom lowered</u>			
over	to 0.75	4	(1.22)
over	0.75 to 50	6	(1.83)
over	50 to 345	10	(3.83)
over	345 to 750	16	(4.87)
over	750 to 1000	20	(6.1)

--- IMPORTANT --- OPERATION OF UNIT

1. Make sure this manual has been thoroughly read by all crane operating personnel and supervisors.
2. A routine inspection of the crane should be mandatory before each operating day. Any defects should be corrected immediately.
3. At a job site the vehicle should be positioned so that the crane can adequately reach the load within the rated capacity (centerline of rotation to hoist hook).
4. Keep the vehicle as level as possible during operation.
5. For electric cranes, **engage emergency brake** and leave ignition on with transmission in neutral (or in park for automatic transmissions). Activate any crane power switches. For Auto Crane units requiring battery and hydraulic operation, **engage emergency brake**, place gear selector in neutral, press clutch, activate PTO, release clutch and after hydraulic fluid is warm, set throttle control to proper engine speed.
6. Always use outriggers from the truck to the ground. Be sure these are firm and adequately positioned. When rotating, **keep load as low to the ground as possible**.
7. Remove the transmitter from cab or storage area. Power transmitter on. Detach hook from dead man. Crane is now ready for operation.
8. Always boom up before rotating so the boom will clear the required boom support.
9. When extending the boom, always maintain clearance between the boom crown and the traveling block or hoist hook.
10. Always observe safe and practical operation to avoid possible accidents. Refer to Safety Tips and Precautions.
11. After completing lifting operations, return the boom to stowed position on the boom support. Avoid unneeded pressure on the boom support.
12. Store transmitter in proper location (in cab or storage area).
13. Return outriggers to stowed position. Make sure they are pinned in place or jacklegs are returned to compartment.
14. Check work area for any tools or equipment not stored.
15. Release throttle control, depress clutch and disengage PTO. Deactivate any crane power switches.
16. Report any unusual occurrence during crane operation that may indicate required maintenance or repair.
17. **NEVER** use two cranes to support a load too large for either crane.

OPERATION OF OUTRIGGERS

HYDRAULIC OUTRIGGERS

1. Shift crane/outrigger control valve to "outrigger" position.
2. Operate the outrigger control valves to position the outriggers.
3. After outriggers are positioned, return crane/outrigger selector to "crane" position.
4. Crane is now ready to operate.

MANUAL OUTRIGGERS

1. Pull lock pins to release jackleg or drop down outrigger and move to outermost lock position.
2. Make sure lock pins are reinstalled properly.
3. Lower outrigger pad to firm ground and adjust foot to take out slack.
4. Crane is now ready to operate.

INSPECTION REQUIREMENTS

REFERENCE ASME B30.5a AND OSHA 1910.180 FOR COMPLETE INSPECTION REQUIREMENTS

INSPECTION CLASSIFICATION

1. Initial inspection.

Prior to initial use, all new, altered, modified or extensively repaired cranes shall be inspected by a designated person to insure compliance with provisions of this standard.

2. Regular inspection.

Inspection procedure for cranes in regular service is divided into two general classifications based upon the intervals at which inspection should be performed. The intervals in turn are dependent upon the nature of the components of the crane and the degree of their exposure to wear, deterioration, or malfunction. The two general classifications are herein designated as "frequent" and "periodic" with respective intervals between inspections as defined below.

- A. Frequent inspection - daily or before each use
- B. Periodic inspection - one to twelve-month intervals or as specifically recommended by the manufacturer or qualified person.

**DESIGNATED PERSONNEL SHALL
PERFORM INSPECTIONS ONLY.**

FREQUENT INSPECTION

Inspections should also occur during operation for any deficiencies that might appear between regular inspections. Any deficiencies, such as those listed below, shall be carefully examined and a determination made as to whether they constitute a hazard:

1. Inspect control mechanisms for maladjustment that interferes with proper operation.
2. Inspect control mechanisms for excessive wear of components and contamination by lubricants or other foreign matter.

3. Inspect safety devices for malfunction.
4. Visually inspect all hydraulic hoses, particularly those that flex in normal operation of crane functions.
5. Inspect hooks and latches for deformation, chemical damage, cracks, and wear. Refer to ANSI/ASME B30.10.
6. Inspect for proper rope reeving.
7. Inspect electrical wiring and components for malfunctioning, signs of excessive deterioration, dirt and moisture accumulation.
8. Inspect hydraulic system for proper oil level and leaks.
9. Inspect tires for recommended inflation pressure, cuts and loose wheel nuts.
10. Inspect connecting pins and locking device for wear damage and loose retaining bolts.
11. Inspect rope for gross damage, such as listed below, which may be an immediate hazard.
 - A. Distortion such as kinking, crushing, unstranding, birdcaging, main strand displacement, or core protrusion. Loss of rope diameter in a short length or unevenness of outer strands should be replaced.
 - B. General corrosion.
 - C. Broken or cut strands.
 - D. Use care when inspecting sections of rapid deterioration around flange points, crossover points, and repetitive pickup points on drums.
 - E. Inspect number, distribution, and type of visible broken wires. Reference Rope Maintenance section in the owner's manual.

Continued use of rope depends upon good judgment by a designated person in evaluating remaining strength in a used rope after allowance for deterioration disclosed by inspection. Continued rope operation depends upon this remaining strength.

INSPECTION REQUIREMENTS

PERIODIC INSPECTION

Any deficiencies, such as those listed below, shall be carefully examined and determination made as to whether they constitute a hazard:

1. Inspect for deformed, cracked or corroded members in the crane structure and entire boom.
2. Inspect for loose bolts, particularly mounting bolts.
3. Inspect for cracked or worn sheaves and drums.
4. Inspect for worn, cracked, or distorted parts such as pins, bearings, shafts, gears, rollers and devices.
5. Inspect for excessive wear on brake and clutch system parts and lining.
6. Inspect crane hooks for cracks.
7. Inspect travel steering, braking, and locking devices for malfunction.
8. Inspect for excessively worn or damaged tires.
9. Inspect hydraulic hose, fittings, and tubing for the following problems:
 - A. Evidence of leakage at the surface of the flexible hose or its junction with metal and coupling.
 - B. Blistering, or abnormal deformation to the outer covering of the hydraulic or pneumatic hose.
 - C. Leakage at threaded or clamped joints that cannot be eliminated by normal tightening or recommended procedures.
 - D. Evidence of excessive abrasion or scrubbing on the outer surface of a hose, rigid tube, or fitting. Means shall be taken to eliminate the interference of elements in contact or otherwise protect the components.
10. Inspect hydraulic pumps and motors for the following problems:
 - A. Loose bolts and fasteners.
 - B. Leaks at joints between sections.
 - C. Shaft seal leaks.
 - D. Unusual noises or vibrations.
 - E. Loss of operating speed.
 - F. Excessive heating of the fluid.
 - G. Loss of pressure.
11. Inspect hydraulic valves for the following problems:
 - A. Cracks in valve housing.
 - B. Improper return of spool to neutral position.
 - C. Leaks at spools or joints.
 - D. Sticking spools.
 - E. Failure of relief valves to attain or maintain correct pressure setting.
 - F. Relief valve pressure shall be checked as specified by the manufacturers.
12. Inspect hydraulic cylinders for the following problems:
 - A. Drifting caused by fluid leaking across piston.
 - B. Rod seals leaking.
 - C. Leaks at welding joints.
 - D. Scored, nicked, or dented cylinder rods.
 - E. Damaged case (barrel).
 - F. Loose or deformed rod eyes or connecting joints.
13. Inspect hydraulic filters for evidence of rubber particles on the filter elements indicating possible hose, "O" ring, or other rubber component deterioration. Metal chips or pieces on the filter may denote failure in pumps, motors, or cylinders. Further inspection will be necessary to determine the origin of the problem before corrective action can be taken.
14. Inspect labels to confirm correct location and legibility. Reference decal layout in this manual for proper location of decals.
15. **Rope Inspections need not be at equal calendar intervals and should be more frequent as the rope approaches the end of useful life.** A qualified person shall inspect the wire rope based on such factors as:
 - A. Expected rope life as determined by experience on the particular installation or similar installations.
 - B. Severity of environment.
 - C. Percentage of capacity lifts.
 - D. Frequency rates of operation.
 - E. Exposure to shock loads.This inspection shall cover the entire length of the rope. Only the surface wires need to be inspected and no attempt should be made to open the rope. Any deterioration resulting in appreciable loss of original strength shall be noted and determination made as to whether use of the rope would constitute a hazard. A few notable deterioration points are listed below:

INSPECTION REQUIREMENTS

- A. Reduction of rope diameter below nominal diameter due to loss of core support.
- B. Internal or external corrosion.
- C. Wear of outside wires.
- D. Severely corroded, cracked, bent, worn, or improperly applied connections.

CRANES NOT IN REGULAR USE

A crane, which has been idle for a period of over one month or more, shall be given an inspection conforming to the "initial" and "regular" inspection requirements of this section.

INSPECTION RECORDS

Dated records of periodic inspection should be made on critical items such as brakes, crane hooks, rope, cylinders, and relief pressure valves.

TESTING REQUIREMENTS

REFERENCE ASME B30.5a AND OSHA 1910.180 FOR COMPLETE TESTING REQUIREMENTS

TESTING SHALL BE PERFORMED BY DESIGNATED PERSONNEL ONLY.

Prior to initial use, all new, altered, modified, or extensively repaired cranes shall be tested for compliance with the operational requirements of this crane.

Test requirements:

1. Test all functions to verify speed and operation.
2. Check that all safety devices are working properly.
3. Confirm operating controls comply with appropriate function labels.
4. Test loads shall not exceed 110% of the manufacturer's load rating.
5. Written reports shall be maintained showing test procedures and confirming the adequacy of repairs.

GENERAL REPAIRS AND MAINTENANCE

REFERENCE ASME B30.5a AND OSHA 1910.180 FOR COMPLETE MAINTENANCE AND REPAIR REQUIREMENTS

A preventative maintenance program should be established based on this section and all replacement parts should be obtained from AutoCrane Company.

For replacement parts contact your local authorized distributor.

MAINTENANCE PRECAUTIONS

1. Place crane where it will cause the least interference with other equipment or operations.
2. Verify all controls are in the "off" position and all operating features secured from inadvertent motion by brakes, pawls, or other means.
3. The means for starting the crane shall be rendered inoperative.
4. The boom should be secured in place before maintenance.
5. Relieve hydraulic oil pressure from all hydraulic circuits before loosening or removing hydraulic components.
6. Warning or "OUT OF ORDER" signs shall be placed on all crane controls.
7. After adjustments and repairs have been made, the crane shall not be returned to service until all guards have been reinstalled, trapped air removed from hydraulic system (if required), safety devices reactivated, and maintenance equipment removed.

ADJUSTMENTS AND REPAIRS

1. Any hazardous conditions disclosed by the inspection requirements shall be corrected before operation of crane is resumed. Only designated personnel shall do adjustments and repairs.
2. Adjustments shall be maintained to assure correct functioning of components, the following are examples:
 - A. Functional operating mechanism.
 - B. Safety devices.
 - C. Control systems.
3. Repairs or replacements shall be provided as needed for operation, the following are examples:
 - A. Critical parts of functional operating mechanisms which are cracked, broken, corroded, bent, or excessively worn.

- B. Critical parts of the crane structure which are cracked, bent, broken, or excessively corroded.
 - C. Crane hooks showing cracks, damage, or corrosion shall be taken out of service. Repairs by welding are not recommended.
4. If bleeding the hydraulic system is required, run each crane function until smooth operation of that particular function is noticeable.

LUBRICATION

All moving parts of the crane, for which lubrication is specified, should be regularly lubricated per the manufacturer's recommendations and procedures. **Reference Lubrication and Maintenance Schedule in this manual.**

ROPE REPLACEMENT

No precise rules can be given for determination of the exact time for replacement of rope, since many variable factors are involved.

1. Conditions such as the following shall be reason for questioning continued use of the rope or increasing the frequency of inspection:
 - A. In running ropes, six randomly distributed broken wires in one lay or three broken wires in one strand in one lay.
 - B. One outer wire broken at the contact point with the core of the rope structure and protrudes or loops out of the rope structure. Additional inspection of this section is required.
 - C. Wear of one third of the original diameter of the outside individual wire.
 - D. Kinking, crushing, bird caging, or any other damage resulting in distortion of the rope structure.
 - E. Evidence of any heat damage from any cause.
 - F. Reduction from nominal diameter of more than 1/64 in. (0.4mm) for diameters up to and including 5/16 in. (8 mm), 1/32 in. (0.8 mm) for diameter 3/8 in. (9.5 mm) to and including 1/2 in. (13 mm), 3/64 in. (1.2 mm) for diameter 9/16 in. (14.5 mm) to and including 3/4 in. (19 mm). 1/16 in. (1.6 mm) for diameter 7/8 in. (22 mm) to and including 1 1/8 in. (29 mm), 3/32 in.

GENERAL REPAIRS AND MAINTENANCE

(2.4 mm) for diameters 1 1/4 in. (32 mm) to and including 1 1/2 in. (38 mm).

- G. In standing ropes, more than two broken wires in one lay in sections beyond end connections or more than one broken wire at an end connection.
- 2. Replacement rope shall have a strength rating at least as great as the original rope furnished or recommended by AutoCrane. A rope manufacturer, AutoCrane, or a qualified person shall specify any deviation from the original size, grade, or construction.

ROPE MAINTENANCE

1. Rope should be stored to prevent damage or deterioration.
2. Unreeling or uncoiling of rope shall be done as recommended by the rope manufacturer and with care to avoid kinking or inducing twist.
3. Before cutting a rope, seizing shall be placed on each side of the place where the rope is to be cut to prevent unlaying of the strands. On pre-formed rope, one seizing on each side of the cut is required. On non-preformed ropes of 7/8 in. (22 mm) diameter or smaller, two seizings on each side of the cut are required, and for non-preformed rope 1 in. (25 mm) diameter or larger, three seizings on each side of the cut are required.
4. During installation care should be exercised to avoid dragging of the rope in the dirt or around objects that will scrape, nick crush or induce sharp bends in it.
5. Rope should be maintained in a well-lubricated condition. It is important that lubricant applied as a part of a maintenance program shall be compatible with the original lubricant and to this end the rope manufacturer should be consulted. Lubricant applied shall be the type that does not hinder visual inspection. Those sections of rope that are located over sheaves or otherwise hidden during inspection and maintenance procedures require special attention when lubricating rope. The object of rope lubrication is to reduce internal friction and to prevent corrosion.
6. When an operating rope shows greater wear or well-defined localized areas than on the remainder of the rope, rope life can be extended in some cases by shifting the wear to different areas of the rope.

MAINTENANCE OF BATTERIES

Maintenance of Auto Crane unit batteries differs very little from the generally prescribed maintenance of any lead acid battery. All batteries must be kept properly charged, properly filled with water, and relatively clean.

Keep Properly Charged

Many things affect the proper charge to a battery, such as:

1. Regulator settings.
2. Proper tightness of belts on the alternator or generator.
3. Good, clean connections of all cables and wires at the following places:
 - a. Battery.
 - b. Regulator.
 - c. Starting motor.
 - d. Alternator or generator.
 - e. Ground connections (most important).

It is of extreme importance to keep the battery as fully charged as possible without overcharging, especially when vehicles are left outside for extended periods in extremely cold climates. A battery can freeze. Freezing points for various specific gravities of acid are as follows:

Specific Gravity (Corrected to 80°F)	Freezing Temp. Degrees F.
1.280	-90°F
1.250	-62°F
1.200	-16°F
1.150	5°F
1.100	19°F

As shown, a half-charged battery (about 1.100 specific gravity) cannot stand for any length of time at 20°F or it will freeze.

The main reason for keeping the battery as fully charged as possible without over-charging is to insure that power is available even though the vehicle has been standing for some time.

Keep Properly Filled with Water

The battery should *always* be properly filled with water. If the electrolyte level is allowed to fall below the top of the plates, the results become threefold:

1. The exposed portion of the plate will become sulfated.
2. The portion of the plate exposed is not usable.
3. That portion of the acid remaining becomes more concentrated and may cause more rapid

deterioration of the remaining parts of the battery.

Keep A Relatively Clean Battery

The battery should be kept clean. Batteries filled with acid and which are not in use self-discharge to a limited degree because of the nature of the materials within the battery. If dirt is allowed to collect on the top of the battery (and this dirt absorbs moisture) and electrical path can be set up between the various terminals of the battery and the ground. Once such a path has been established, the self-discharge of the battery is accelerated. This also accelerates corrosion of the battery cables at the terminals.

Periodic Maintenance is Needed

A definite program of periodic maintenance of all batteries should be conducted on a regular basis. Periodic maintenance includes:

1. Checking belts for tightness on the charging equipment.
2. Checking battery electrolyte levels.
3. Checking cables for good connections.
4. Cleaning where corrosion is apparent.

When corrosion is cleaned off, the cable terminals and battery terminals should be coated with a light coating of petroleum jelly before they are replaced. When terminals are cleaned, the top of the battery should be cleaned with a mild solution of soda water.

Low Maintenance Batteries (Maintenance Free)

Low maintenance batteries should not be used on AutoCrane Cranes or trucks equipped with AutoCrane Cranes. The batteries are not designed for "deep" discharge.

Testing Your Battery

If the condition of the battery is in question, it should be removed from the vehicle, taken to the shop, and allowed to reach room temperature. It should then be recharged until specific gravity readings taken at one-half hour intervals. If the specific gravity readings are fairly uniform, the battery should be checked with a high rate tester. Use the tester in accordance with the manufacturer's instructions. The high rate tester is the best method to test a questionable battery.

MAINTENANCE OF BATTERIES

If, after charging, it is noted that the specific gravity reading of one cell is 30 points less than any of the other cells, it may be assumed that the cell is bad and that the battery should be replaced. If all cells are uniform but not up to full charge, a low rate of charge should be attempted for an extended time. This usually will recover a badly sulfated battery.

Replacing a Battery

If it is necessary to replace a battery, and a dry charge battery is used, the following procedure applies:

1. Fill the battery with electrolyte of the proper specific gravity.

2. Place the battery on charge according to the manufacturer's instructions.

It is essential that the second step above be followed to ensure that the battery going on the vehicle is fully charged.

It is also very important that the battery hold-downs be checked periodically to insure that the batteries are properly positioned to avoid vibration problems, breakage of cables or terminals. Care must be taken to avoid cracking or breaking containers or covers by tightening hold-down fixtures excessively. They also must not be so loose that breakage results from a hold-down that is too loose.

2003 LUBRICATION & MAINTENANCE SCHEDULE

SERVICE PERFORMED	DAY	WKLY	3 MOS	6 MOS	YEAR	NOTES
LOAD HOOK	X					INSPECT HOOK & LATCH FOR DEFORMATION, CRACKS, & CORROSION
CABLE DRUM	X					MAKE SURE CABLE IS WOUND EVENLY ON DRUM
HOIST / BOOM CABLE	X					CHECK FOR FLATTENING, KINKS, & BROKEN STRANDS, SEE MANUAL
PIN RETAINING BOLTS	X					CHECK TORQUE TO 23 FT-LBS (GRADE 5), 35 FT-LBS (GRADE 8) AS REQUIRED
MOTOR CONNECTIONS		X				CHECK TERMINALS FOR TIGHT CONNECTIONS
MOUNTING BOLTS		X				CHECK TORQUE TO 335 FT-LBS FOR 3/4-16
SHEAVE BEARINGS		X				SEALED BEARING, REPLACE IF ROUGH OR LOOSE
ALL OTHER BOLTS		X				CHECK TIGHTEN AS REQUIRED
BATTERY CONNECTIONS		X				CHECK FOR CORROSION & TIGHT CONNECTIONS. CLEAN & COAT AS REQUIRED
ROTATION BRAKE		X				CHECK ADJUSTMENT
BOOM PIVOTS		X				GREASE WITH MOBILEPLEX EP-2 OR EQUIVALENT @ ZERKS
POWER CABLE			X			CHECK INSULATION FOR DAMAGE OR DETERIORATION
ROTATION BEARING			X			GREASE WITH MOBILEPLEX EP-2 OR EQUIVALENT @ ZERKS
ROTATION BEARING BOLTS			X			CHECK TORQUE TO 170 FT-LBS (HEX HEAD)
HOIST GEARBOX				X		WORM GEAR-EP GEAR LUBE SAE 80-90; SPUR GEAR GEARS-SAE 30 OIL
BOOM SLIDE PADS	PADS GREASED WHEN REPLACED					
FOR ADDITIONAL INFORMATION SEE:	1) OWNER'S MANUAL 2) OSHA SECTION 1910.180 3) ANSI B30.5-1989					

CAUTION: Routine maintenance insures trouble-free operation and protects your investment. All warranties are void if maintenance is neglected.

2003

LUBRICATION & MAINTENANCE SCHEDULE

NOTES:

1. Use only authorized parts. Any damage or malfunction caused by the use of unauthorized parts is not covered by Warranty or Product Liability.
2. Once a bolt has been torqued to its rated capacity and then removed; the bolt should be replaced with a new one.
3. Auto Crane Company recommends that this crane be serviced per "Crane Inspection Log" P/N 999978. These logs should be filled in at the intervals noted and kept as a permanent record. Additional copies are available from your local distributor.

NOTES

2003 SAFETY DECAL SECTION

PART NO.: 040579000
 DECAL: OPERATING INSTRUCTIONS
 FUNCTION: To inform the operator of the proper procedure to follow for safe operation of the crane.
 USED ON: All Cranes
 QUANTITY: 1
 PLACEMENT: Left side of hoist

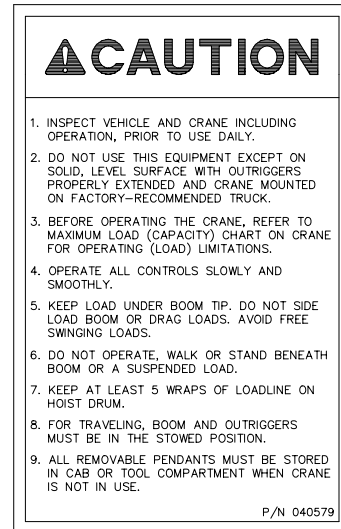

PART NO.: 370496000
 DECAL: OPERATING TRAINING
 FUNCTION: To inform the operator of the need to receive proper training before using the crane.
 USED ON: All Cranes
 QUANTITY: 1
 PLACEMENT: Right side of lower boom

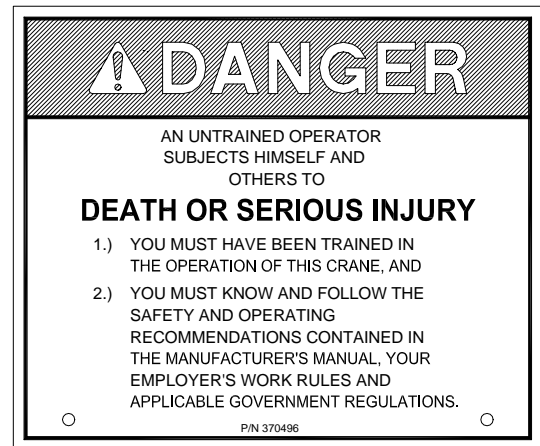

PART NO.: 040529000
 DECAL: ELECTROCUTION HAZARD
 FUNCTION: To inform the operator of the hazard involved with contacting electrical power lines with crane boom.
 USED ON: All Cranes
 QUANTITY: 2
 PLACEMENT: Both sides of lower boom

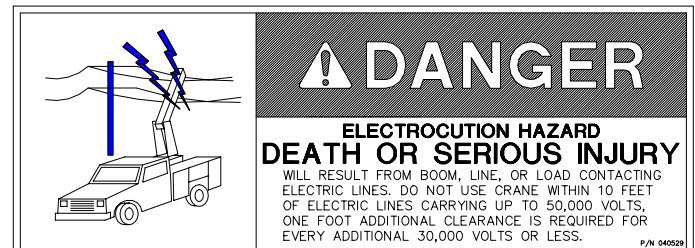

2003 SAFETY DECAL SECTION

PART NO.: 040517000
 DECAL: STAY CLEAR OF BOOM
 FUNCTION: To inform the operator of the hazard of proximity or contact with the crane boom during operation.
 USED ON: All Cranes
 QUANTITY: 2
 PLACEMENT: Both sides of crown

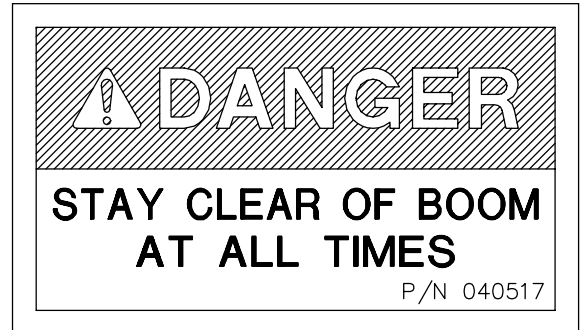

PART NO.: 040518000
 DECAL: STAY CLEAR OF LOAD
 FUNCTION: To inform the operator of the hazard of proximity or contact with the crane load during operation.
 USED ON: All Cranes
 QUANTITY: 2
 PLACEMENT: Both sides of down haul block



PART NO.: 040519000
 DECAL: SCISSORS POINT
 FUNCTION: To inform the operator of possible danger at scissors point on crane.

USED ON: All cranes.
 QUANTITY: 2
 PLACEMENT: Left side of lower boom

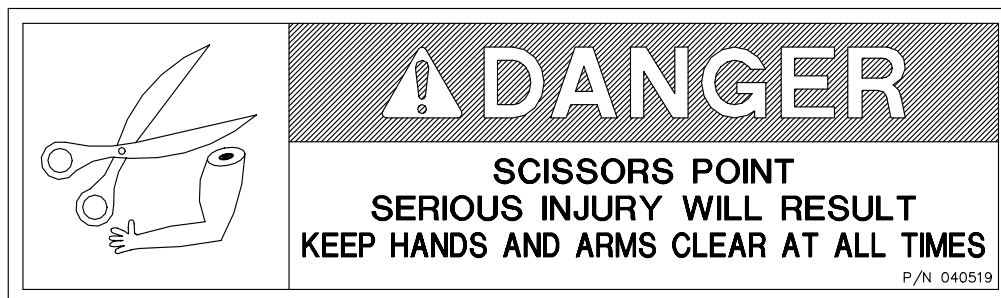

2003 DECAL LAYOUT

P/N: 600934000

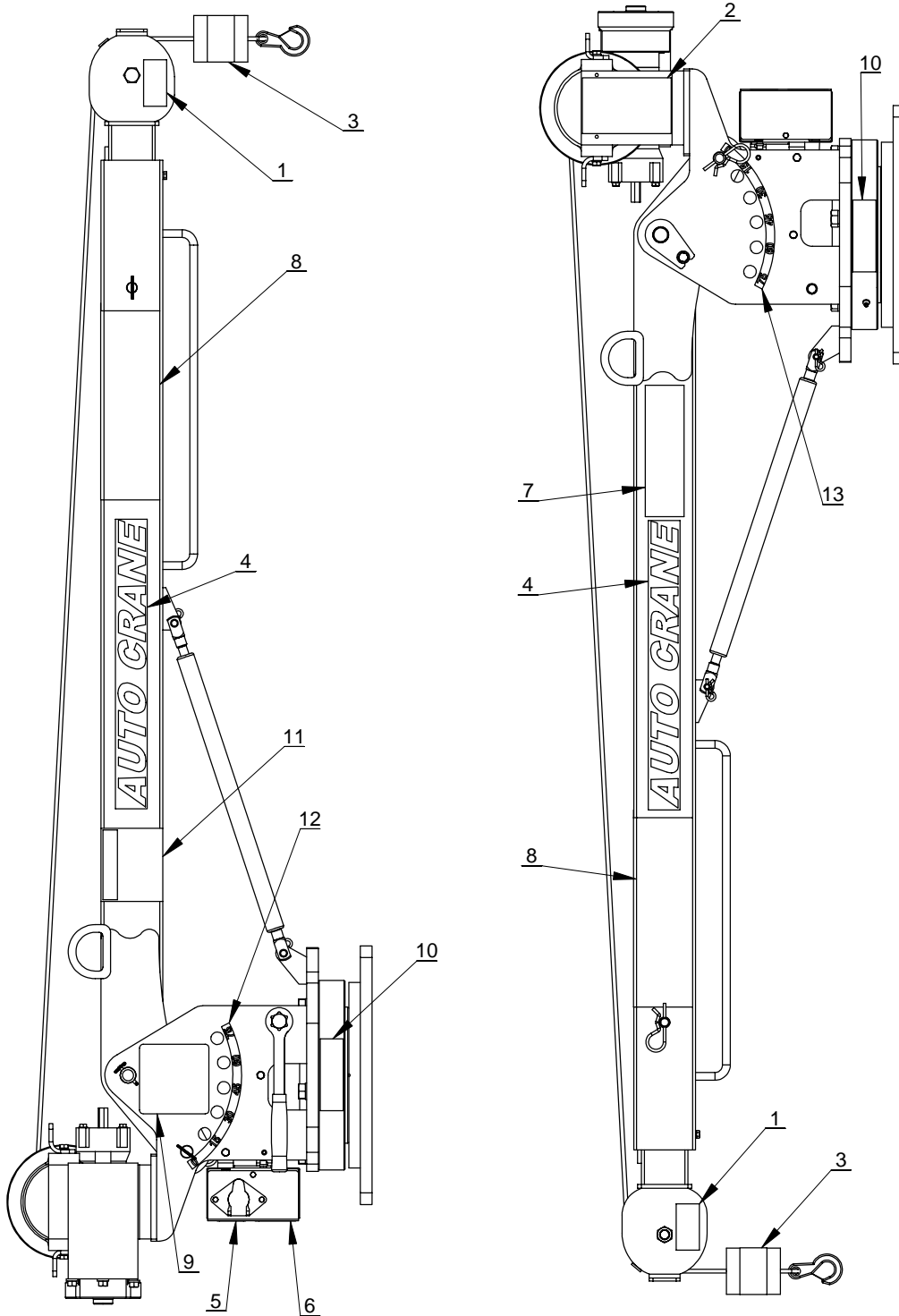

2003 DECAL LAYOUT

P/N: 600934000

ITEM NO.	QTY	PART NUMBER	DESCRIPTION
1	2	040517000	DECAL STAY CLEAR OF BOOM
2	1	040579000	DECAL OPERATION INSTRUCTIONS
3	2	040518000	DECAL STAY CLEAR OF LOAD
4	2	600047000	DECAL AUTO CRANE
5	1	040619001	DECAL AUTO CRANE LOGO
6	1	040824000	DECAL, AMERICAN FLAG, MADE IN THE U.S.A.
7	1	040519000	DECAL DANGER SCISSOR POINT
8	2	040529000	DECAL DANGER "ELECTROCUTION HAZARD" POWER LINE
9	1	600938000	LOAD CHART, 2003
10	2	600939000	2003 DECAL, 2003
11	1	370496000	DECAL, DANGER "UNTRAINED OPERATOR"
12	1	600949000	ANGLE CALLOUT DECAL, CS
13	1	600950000	ANGLE CALLOUT DECAL, SS

2003 GENERAL DIMENSIONS

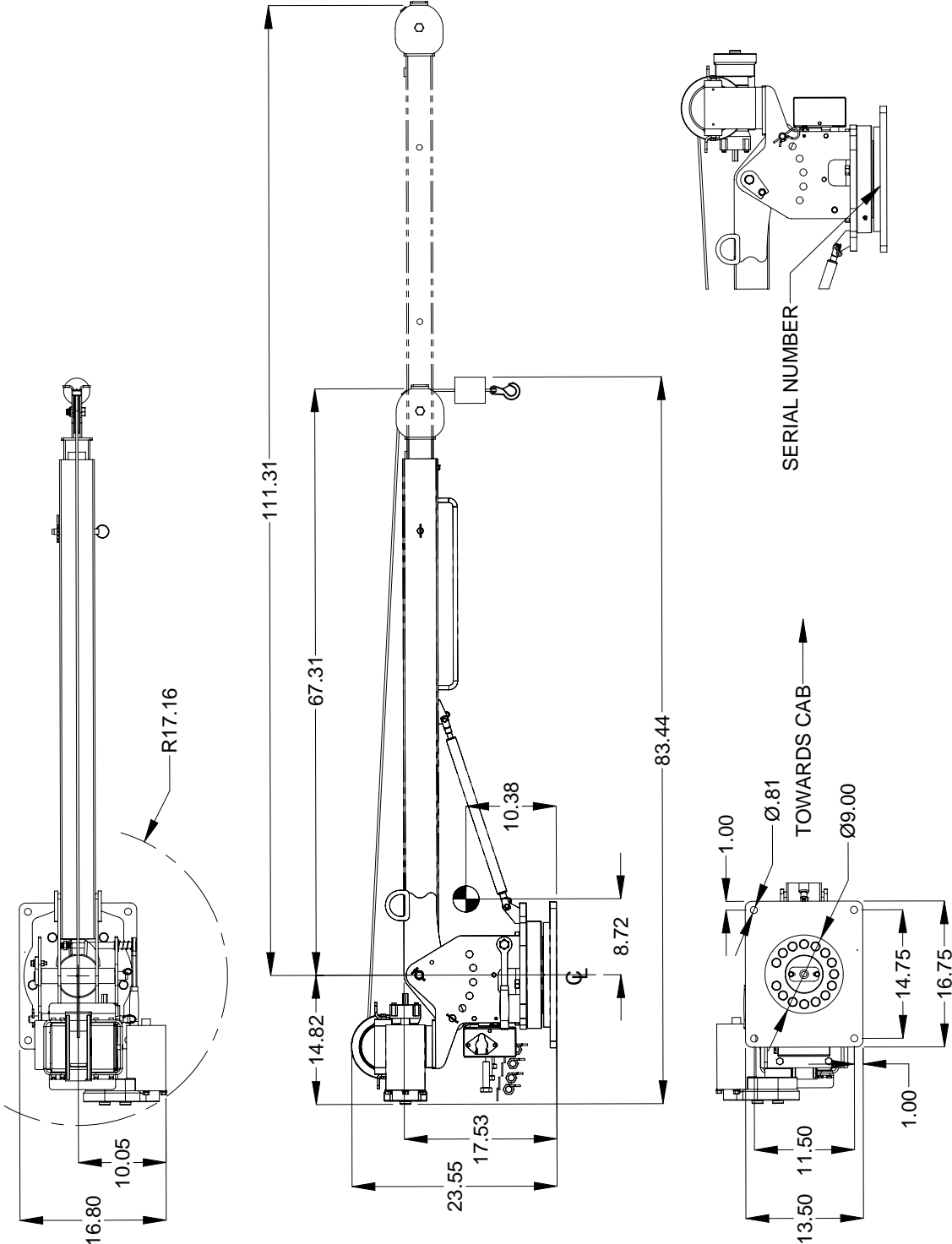

NOTE: CG IS APPROXIMATE

2003 MOUNTING AND INSTALLATION

1. Check to make sure the following items are with your crane.

ITEM	QTY	PART NO.	DESCRIPTION
1	1	999951000	2003 OWNERS MANUAL
2	6	083800000	CLIP, CABLE #838 (FRAME)
3	4	404226000	SCREW, HX HD, 3/4-16UNF X 3" LG. GRADE 8
4	4	404227000	NUT, HX 3/4-16UNF
5	4	022101000	WASHER, SP. LK. 3/4
6	4	022102000	WASHER FL 3/4

2. Vehicle should meet minimum GVW rating of 8,000 pounds. (does not include bodies or accessories)
3. Make sure mounting surface is properly reinforced to withstand 6,000 ft-lbs capacity loading of crane and that outriggers are used to provide total stability for the truck.
4. A 9" diameter hole should be cut out of mounting location (centered with mounting bolts) for access. Reference general dimensions for bolt pattern.
5. Make sure the mounting bolts are 3/4"-16UNF, grade 8UNF. Torque bolts to 335 ft-lbs (dry).
6. Run long cable to positive battery terminal. Run short cable to a suitable chassis ground point. Locate cables so that they will be protected. Avoid sharp edges. Use the frame clips provided to hold the cables securely in place.
Note: If the battery is grounded to the engine it may be necessary to add an additional ground cable from the engine to the chassis frame to obtain maximum power at crane.
7. Load test the crane to ensure proper functioning and truck stability.
8. When crane is not in operation, the hook should be connected to a hook loop.
9. Make certain the owner's manual is delivered to the customer.
10. For additional help: call the service department at the Auto Crane Company. (918) 836-0463 (Tulsa, Oklahoma)

WARNING

FEDERAL LAW (49 CFR PART 571) REQUIRES THAT THE FINAL STAGE MANUFACTURER OF A VEHICLE CERTIFY THAT THE VEHICLE COMPLIES WITH ALL APPLICABLE FEDERAL REGULATIONS. ANY MODIFICATIONS PERFORMED ON THE VEHICLE PRIOR TO THE FINAL STAGE ARE ALSO CONSIDERED INTERMEDIATE STAGE MANUFACTURING AND MUST BE CERTIFIED AS TO COMPLIANCE. THE INSTALLER OF THIS CRANE AND BODY IS CONSIDERED ONE OF THE MANUFACTURERS OF THE VEHICLE. AS SUCH A MANUFACTURER, THE INSTALLER IS RESPONSIBLE FOR COMPLIANCE WITH ALL APPLICABLE FEDERAL AND STATE REGULATIONS, AND IS REQUIRED TO CERTIFY THAT THE VEHICLE IS IN COMPLIANCE.

IT IS THE FURTHER RESPONSIBILITY OF THE INSTALLER OF THE CRANE TO COMPLY WITH THE OSHA TRUCK CRANE STABILITY REQUIREMENTS AS SPECIFIED BY 29 CFR PART 1910.180 (C) (1).

NOTES

OPERATING INSTRUCTIONS

2003 SERIES

To Extend:

Turn Brake Handle (1) counter clock-wise to release brake and turn boom to a convenient location for extending boom. Tighten Brake by turning Brake Handle clock-wise. Use pendant control to let out more cable for boom extension. Remove Boom Extension Pin (2) in lower Boom (3). Slide Upper Boom out of Lower Boom until a new set of pin holes in Upper Boom appear in pin hole in Lower boom. Replace Pin in Lower Boom. Boom is now ready to raise.

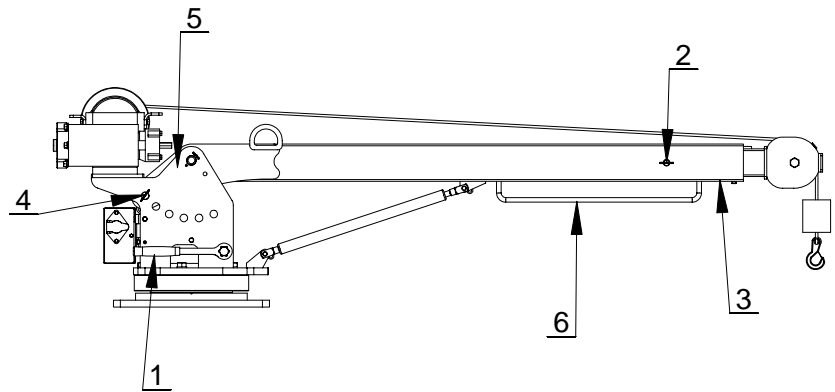

To Raise:

Use pendant control to let out more cable for boom elevation. Remove Hitch Clip from Boom Elevation Pin (4) in Boom Housing (5). Place hand on Lower Boom Handle (6) and gently pull down on handle. Pull Boom Elevation Pin out of Boom to desired elevation. Align tube in Boom with holes in Housing and replace Boom Elevation Pin. Replace Hitch Clip on Boom Elevation Pin. The crane is now ready to lift the load.

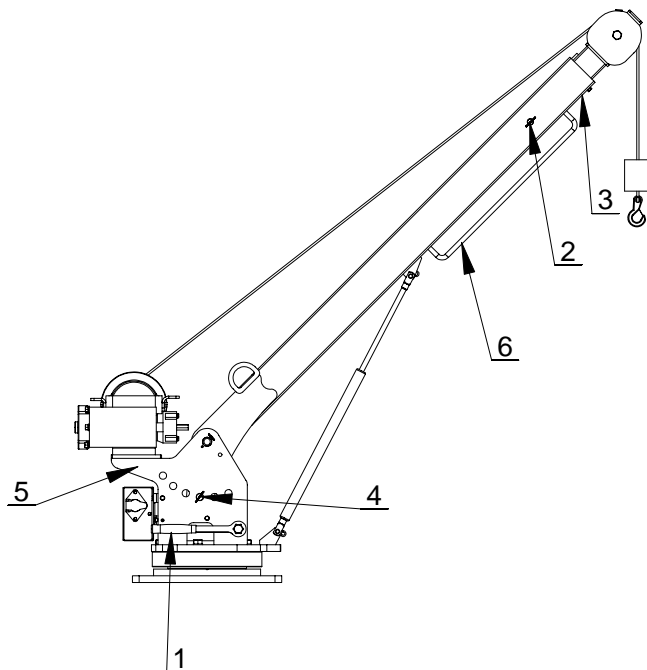

CAUTION:

DO NOT STAND DIRECTLY UNDER BOOM WHEN RAISING OR LOWERING BOOM OR SERIOUS INJURY MAY RESULT.

GENERAL ASSEMBLY

P/N: 60090000

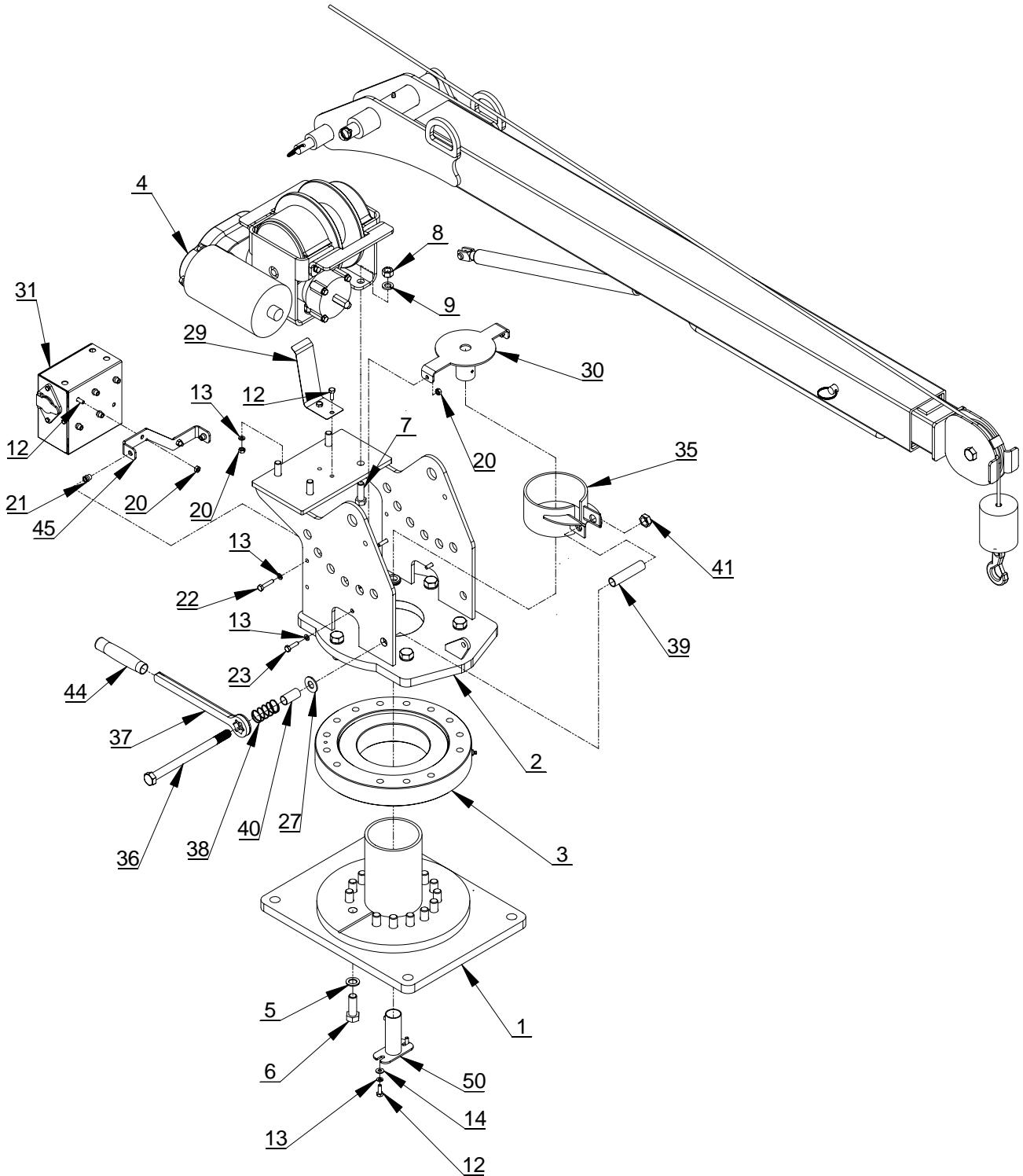

GENERAL ASSEMBLY

P/N: 600900000

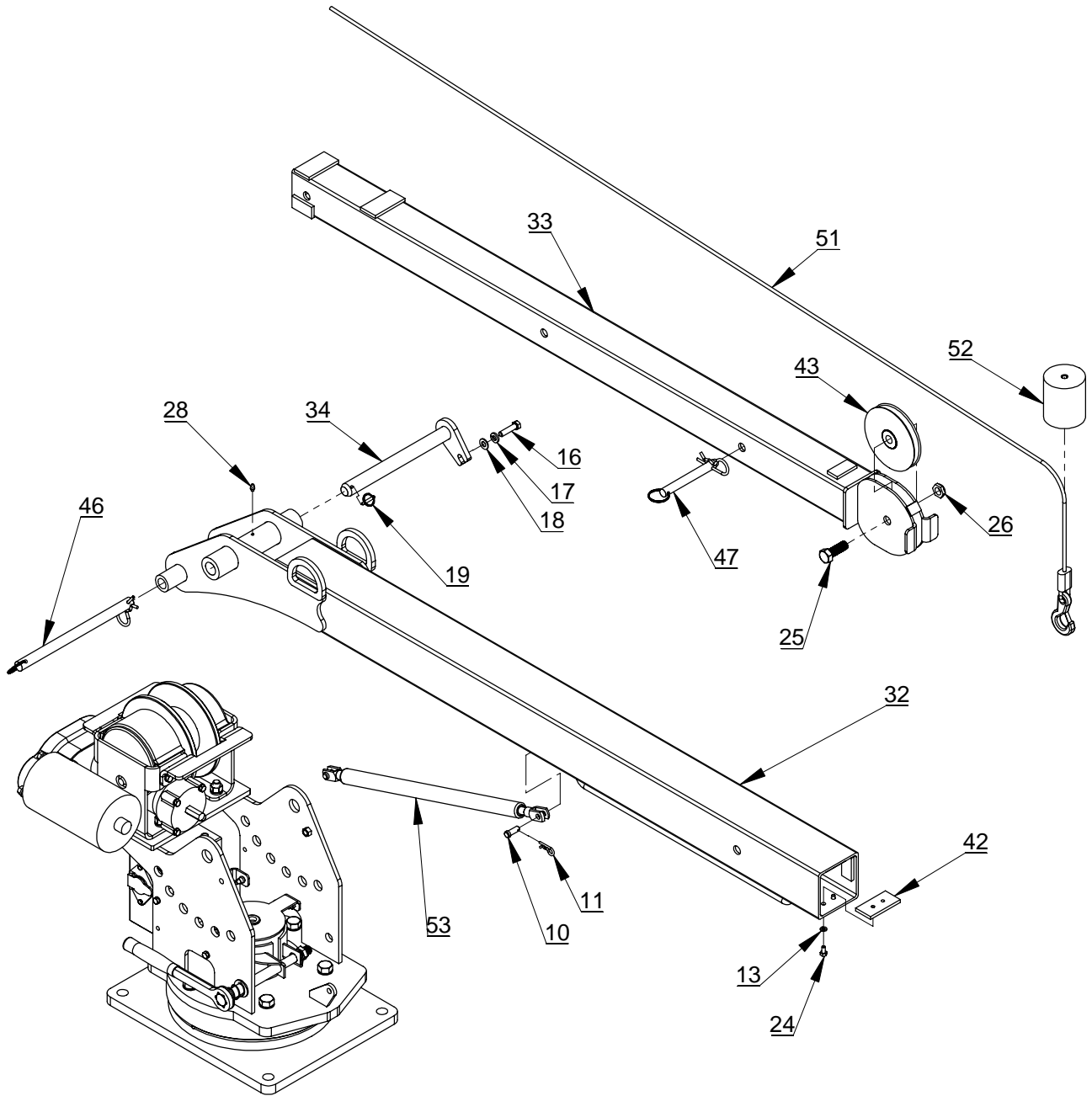

GENERAL ASSEMBLY

P/N: 600900000

ITEM NO.	QTY	PART NUMBER	DESCRIPTION
1	1	600901000	BASE WELDMENT, 2003
2	1	600904000	PEDESTAL WELDMENT, 2003
3	1	320878000	ROTATION BEARING
4	1	110703000	WINCH ASSEMBLY
5	23	023902000	WASHER FL 5/8 HARDENED
6	23	012198000	SCREW HX HD 5/8-11UNC X 1 3/4 LG GR8
7	4	010201000	SCREW HX HD 1/2-13UNC x 1 1/2 LG
8	4	017701000	NUT HX 1/2-13UNC
9	4	021500000	WASHER SP LK 1/2
10	2	600941000	CLEVIS PIN, 3/8 DIA, 2003
11	2	600942000	HAIR PIN COTTER PIN, 1.25", 2003
12	6	005500000	SCREW HX HD 1/4-20UNC X 3/4 LG
13	12	020200000	WASHER SP LK 1/4
14	2	020300000	WASHER FL 1/4
15	1	330372000	NUT HX 3/8-16UNC
16	1	009109000	SCREW HX HD 3/8UNC-16 X 1 1/2 LG
17	1	021100000	WASHER SP LK 3/8
18	1	021200000	WASHER FL 3/8
19	1	360678000	PIN, 3/16 COTTERLESS RING
20	6	015900000	NUT HX 1/4-20UNC SS
21	2	736272000	NUTSERT 1/4-20UNC X .027-.165 GRIP
22	2	005700000	SCREW HX 1/4 NC X 1 1/4
23	2	005604000	SCREW HX HD 1/4-20UNC X 1 LG
24	2	005901000	SCREW HX HD 1/4-20UNC X 1/2 LG
25	1	012200000	SCW HX HD 5/8 X 1 3/4NF GR5
26	1	018100000	5/8-18 HX HALF
27	1	021801000	WASHER FL 5/8X1 5/16O.D.
28	1	239000000	ZERK DRIVE GR
29	1	320442000	GUARD CABLE RETAINER
30	1	600907000	BRACKET ASSY, UPPER, TWECO, 2003
31	1	600945000	RELAY KIT, 2003
32	1	600910000	LOWER BOOM ASSY, 2003
33	1	600917000	UPPER BOOM ASSY, 2003
34	1	404220000	PIN WDMT BOOM/PED
35	1	600924000	BRAKE BAND WELDMENT, 2003
36	1	600927000	CAPSCREW, HEX, GR 5, 5/8-11 UNC-2A
37	1	600057000	BRAKE HANDLE WDMT
38	1	320509000	SPRING, COMPRESSION
39	1	600928000	SPACER, 2003
40	1	330489000	SPACER
41	1	018201000	NUT HX 5/8 NCCP
42	1	600929000	PAD, 3 X 1.5 X .25, 2003
43	1	227401000	SHEAVE ASSY

GENERAL ASSEMBLY

P/N: 60090000

ITEM NO.	QTY	PART NUMBER	DESCRIPTION
44	1	600058000	HAND GRIP, 2003 CRANE
45	1	600909000	BRACKET, RELAY PANEL, 2003
46	1	600930000	PIN ASSY, BOOM PIVOT, 2003
47	1	600931000	PIN ASSY, BOOM EXT, 2003
48	1	600943000	SHIP KIT, 2003
49	1	600934000	DECAL LAYOUT, 2003
50	1	600935000	BRACKET, LOWER TWECO, 2003
51	1	600037000	CABLE 1/4 X 50 FOOT WITH HOOK
52	1	600060000	DOWN HAUL WEIGHT 2003 CRANE
53	1	600923000	GAS SPRING, 15.34 STROKE, 2003
54	1	750169000	GROMMET, RUBBER

2003 HOIST ASSEMBLY

P/N: 110703

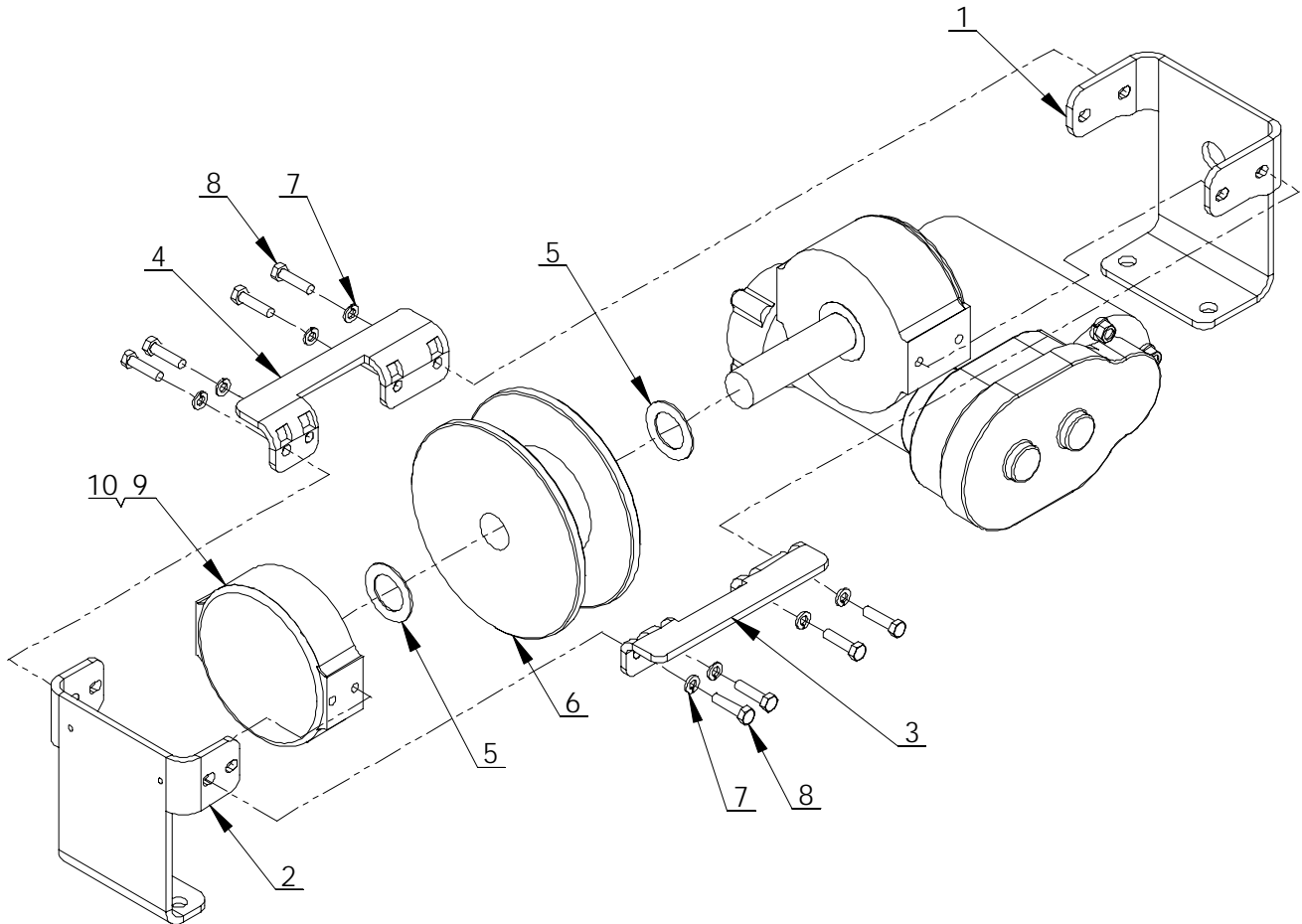

ITEM NO.	QTY.	PART NO.	DESCRIPTION
1	1	320836000	WINCH MOUNTING BRACKET CS
2	1	320837000	WINCH MOUNTING BRACKET SS
3	1	320838000	WINCH TIE BAR
4	1	320838001	WINCH TIE BAR, FRONT
5	2	320887000	BEARING, BRONZE
6	1	320379000	DRUM
7	8	020601000	WASHER SP LK 5/16
8	8	007804000	SCREW HX HD 5/16-18UNC X 1 1/4 LG CP
9	1	412003	FLANGE BEARING
10	1	338053	WINCH END BEARING

2003 HOIST ACTUATOR ASSEMBLY

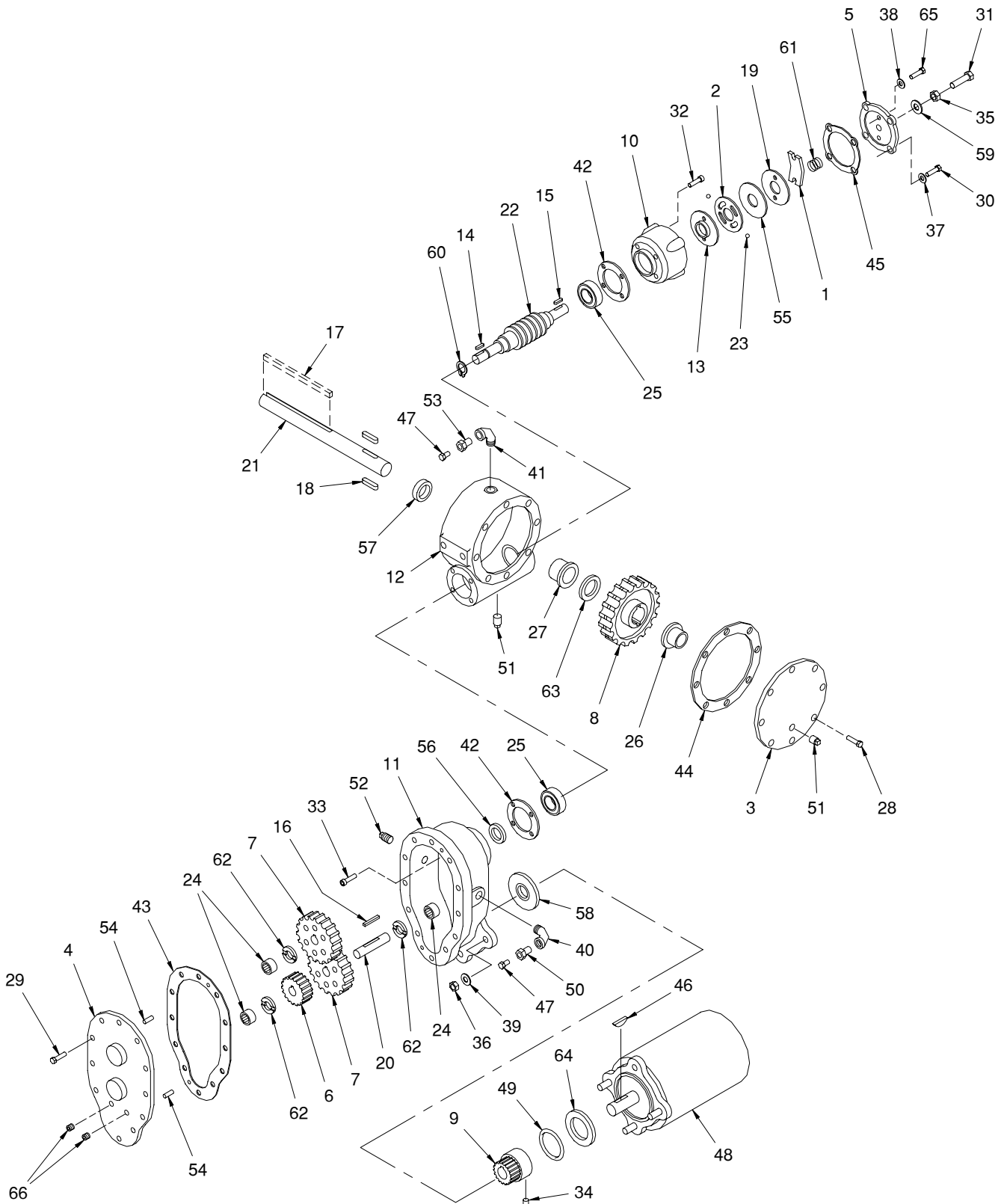

6.6-0

03/15/07

2003 HOIST ACTUATOR ASSEMBLY

ITEM NO.	QTY.	PART NO.	DESCRIPTION
1	1	306034	SPRING FLAT
2	1	314008	PLATE CAM
3	1	328009	COVER GEAR HOUSING
4	1	328106	COVER WORM GEAR HOUSING
5	1	328128	COVER BRAKE
6	1	334001	IDLER GEAR
7	2	334003	SPUR GEAR
8	1	334007	GEAR WORM RH
9	1	334129	GEAR PINION
10	1	338007	HOUSING BRAKE
11	1	338203	SPUR GEAR HOUSING
12	1	338238	GEAR HOUSING
13	1	340002	HUB BRAKE
14	1	342023	KEY 3/16 SQ X 1/2 LG
15	1	342027	KEY 3/16 SQ X 1 LG
16	1	342033	KEY 3/16 SQ X 1 7/16 LG
17	1	342198	KEY 1/4 SQ X 2 1/8 LG
18	2	342075	KEY RD 5/16 X 5/16 X 15/16 LG
19	1	352022	PLATE RETAINER
20	1	356901	SPUR GEAR SHAFT
21	1	357515	OUTPUT SHAFT
22	1	368192	WORM R.H.
23	2	400003	BALL
24	3	402001	BEARING NEEDLE
25	2	402002	BEARING BALL
26	1	412003	BUSHING
27	1	412046	BUSHING
28	8	414020	SCREW HX HD 1/4-20UNC X 3/4 LG NY LK
29	12	414038	SCREW HX HD 1/4-20UNC X 3/4 LG
30	4	414039	SCREW HX HD 1/4-20UNC X 1 LG
31	1	414224	SCREW HX HD 3/8-16UNC X 1 1/2 LG ALL THD
32	4	414821	SCREW BTN HD 1/4-20UNC X 7/8 LG
33	4	414845	SCREW SOC HD 1/4-20UNC X 1 LG
34	1	416029	SCREW SET 1/4-20UNC X 5/16 LG LOC-WEL
35	1	418036	NUT JAM 3/8-16UNC
36	3	418040	NUT HX 3/8-24UNF
37	4	486070	WASHER SP LK 1/4 MED SECT
38	2	418154	WASHER FL 1/4 ALUM
39	3	418177	WASHER SP LK 3/8
40	1	432011	ELL 90 DEG 3/8-18 NPT BOTH ENDS
41	1	432012	ELL 90 DEG 1/4-18 NPT BOTH ENDS
42	2	442184	GASKET BEARING
43	1	442185	GASKET SPUR GEAR HOUSING
44	1	442186	GASKET GEAR HOUSING COVER

2003 HOIST ACTUATOR ASSEMBLY

ITEM NO.	QTY.	PART NO.	DESCRIPTION
45	1	442189	GASKET BRAKE COVER
46	1	450001	KEY WOODRUFF
47	2	456008	FITTING RELIEF
48	1	458071	MOTOR 12V
49	1	462015	O-RING 1" OD X 1/8 THK
50	1	468002	REDUCER -6NPT/-2NPT
51	2	468010	PLUG PIPE -4NPT SQ HD
52	1	468018	PLUG PIPE -6NPT HX SOC HEADLESS
53	1	468024	REDUCER -4NPT/-2NPT
54	2	470001	PIN DOWELL
55	1	474001	PLATE THRUST
56	1	486009	OIL SEAL 3/4 ID X 1 1/4 OD X 1/4 THK
57	1	486017	OIL SEAL 1 1/4 ID X 1 3/4 OD X 1/4 THK
58	1	486023	OIL SEAL 1 1/2 ID X 2 1/4 OD X 5/16 THK
59	1	486069	THREAD SEAL
60	1	490003	SNAP RING
61	1	494007	SPRING
62	3	518002	WASHER THRUST
63	1	518015	WASHER THRUST
64	1	518018	WASHER FIBER
65	1	414021	SCREW HX HD 1/4-20UNC X 1 LG NYLK
66	2	468017	PIPE PLUG SOC HD -4NPT

NOTES

PENDANT ASSEMBLY

P/N: 330519000

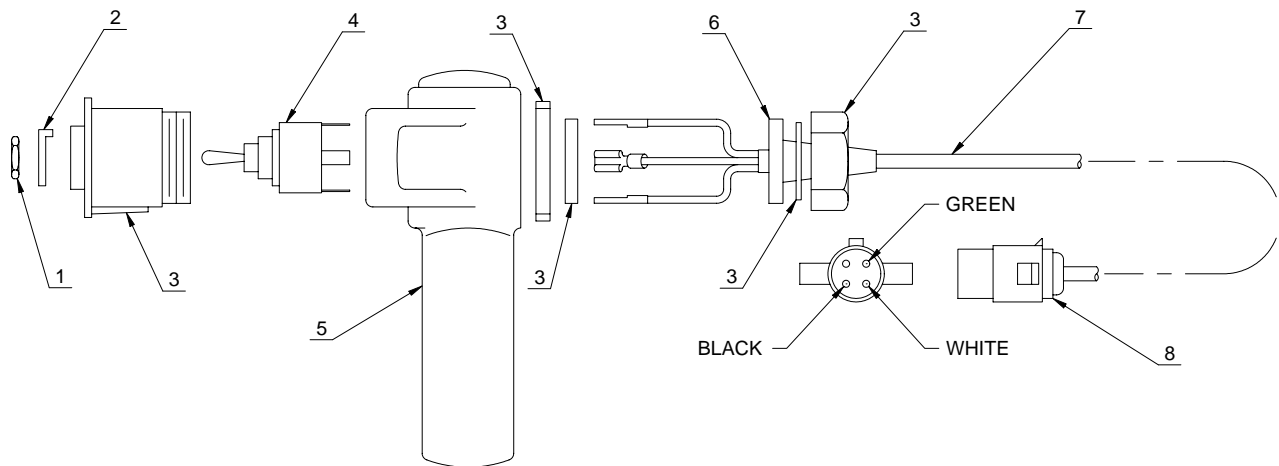

ITEM NO.	QTY.	PART NO.	DESCRIPTION
1	1	675271000	NUT HX
2	1	675281000	WASHER TANG
3	1	675206000	HOUSING KIT
4	1	675202000	SWITCH W/SEAL NUT
5	1	675201000	HOUSING
6	1	675261000	SEAL
7	1	675291000	CABLE PENDANT
8	1	330518000	FEMALE PLUG

2003 RELAY ASSEMBLY

P/N: 600946000

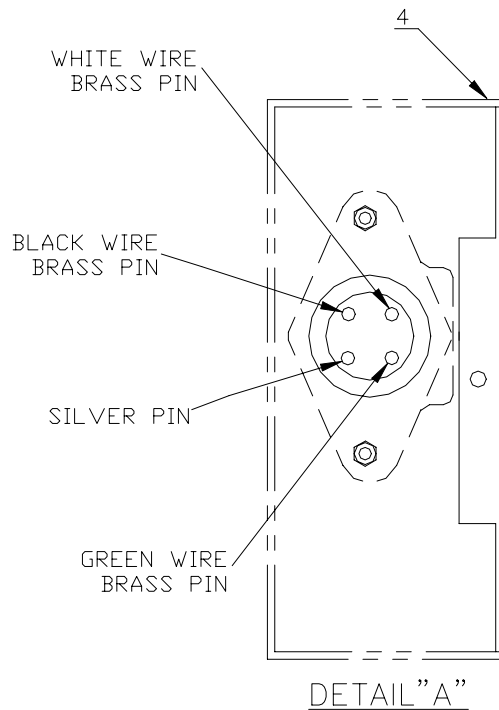
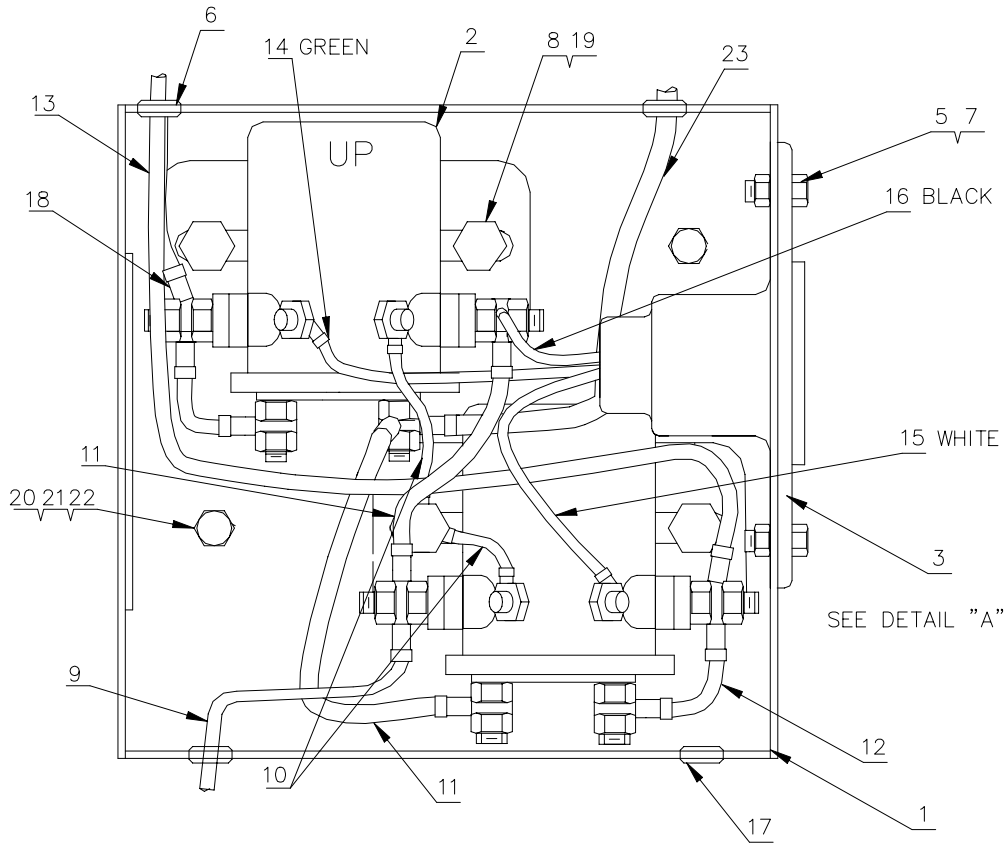

2003 RELAY ASSEMBLY

P/N: 600946000

ITEM NO.	QTY.	PART NO.	DESCRIPTION
1	1	600068000	RELAY GUARD BACK
2	2	330033000	RELAY 12V
3	1	330517000	SOCKET MALE
4	1	600069000	RELAY GUARD FRONT
5	4	001701000	SCREW RD HD #10 NF X 5/16
6	4	600065000	GROMMET 1/2 DIA
7	2	015800000	LOCKNUT #10 NF
8	4	736273000	NUTSERT 5/16 NC X .027-.150 GRIP
9	1	600947000	CONDUCTOR 6 GA X 22 BLK
10	2	600074000	CONDUCTOR 16 GA X 4 1/2 BLK/WHT TRACER
11	1	330037000	CONDUCTOR 8 GA X 3 1/2 BLK
12	3	330036000	CONDUCTOR 8 GA X 2 3/4 BLK
13	1	600951000	CONDUCTOR 6 GA X 26 BLK
14	1	600061000	CONDUCTOR 16 GA X 8 GRN
15	1	600062000	CONDUCTOR 16 GA X 6 WHT
16	1	600063000	CONDUCTOR 16 GA X 6 BLK
17	1	600067000	SNAP PLUG 1/2 DIA
18	1	600952000	CONDUCTOR 6 GA X 23 BLK
19	4	007401000	SCREW HX HD 5/16 NC X 1/2
20	2	015900000	NUT HX HD 1/4 NC
21	2	005604000	SCREW HX HD 1/4 NC X 1
22	2	020300000	WASHER FLAT 1/4
23	1	600948000	CONDUCTOR 6 GA X 24 BLK

WIRING DIAGRAM 2003 SERIES

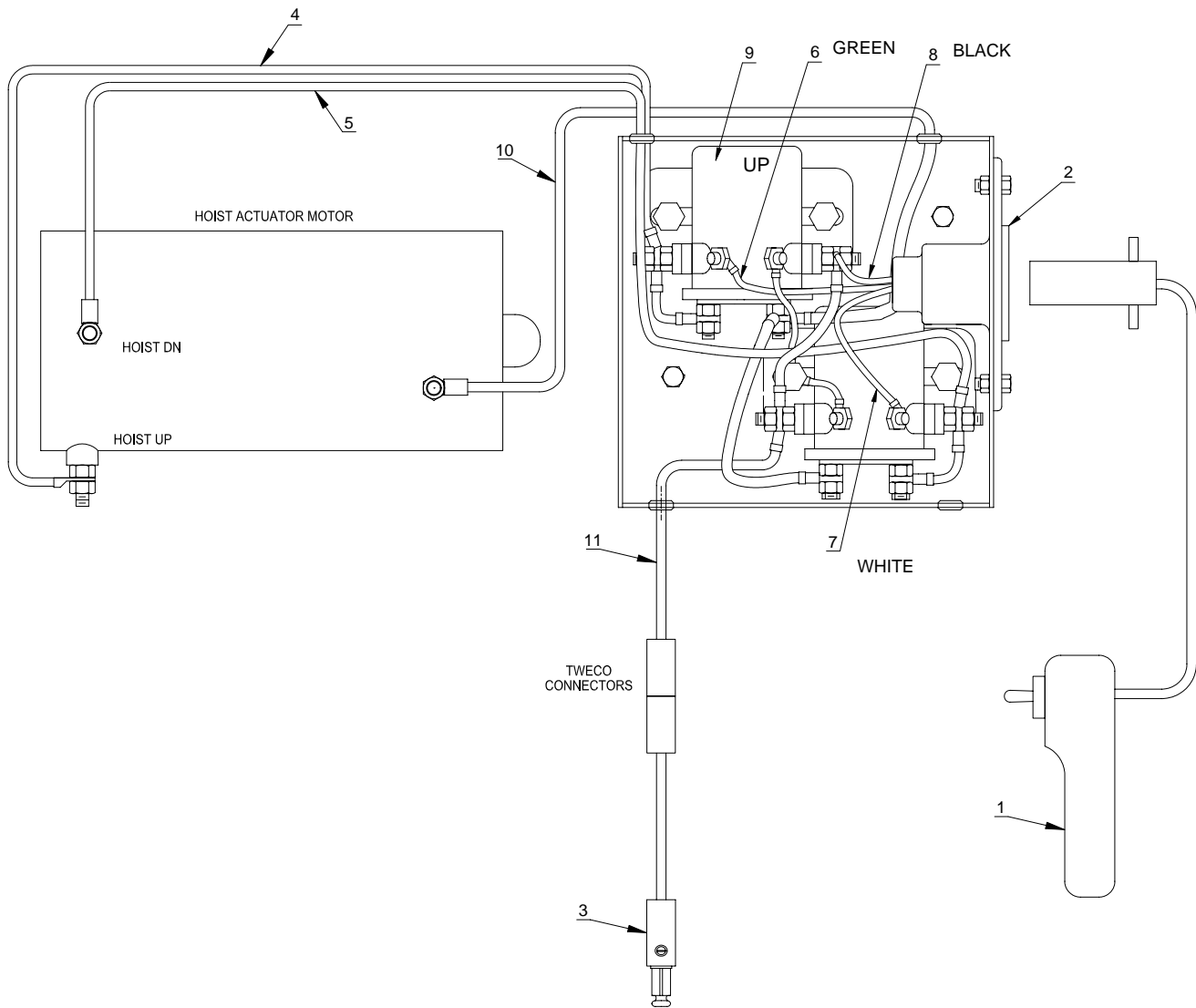

ITEM NO.	QTY.	PART NO.	DESCRIPTION
1	1	330519000	HOIST CONTROL PENDANT
2	1	330517000	FEMALE SOCKET
3	1	600016000	POWER CABLE ASSEMBLY
4	1	600952000	CONDUCTOR 6 GA X 23 BLK
5	1	600951000	CONDUCTOR 6 GA X 26 BLK
6	1	600061000	CONDUCTOR 16 GA ST GREEN X 2 3/4"
7	1	600062000	CONDUCTOR 16 GA ST WHITE X 2 3/4"
8	1	600063000	CONDUCTOR 16 GA ST BLACK X 1 1/4"
9	2	330033000	12V RELAY
10	1	600948000	CONDUCTOR 6 GA X 24 BLK
11	1	600947000	CONDUCTOR 6 GA X 22 BLK

SCHEMATIC 2003 SERIES

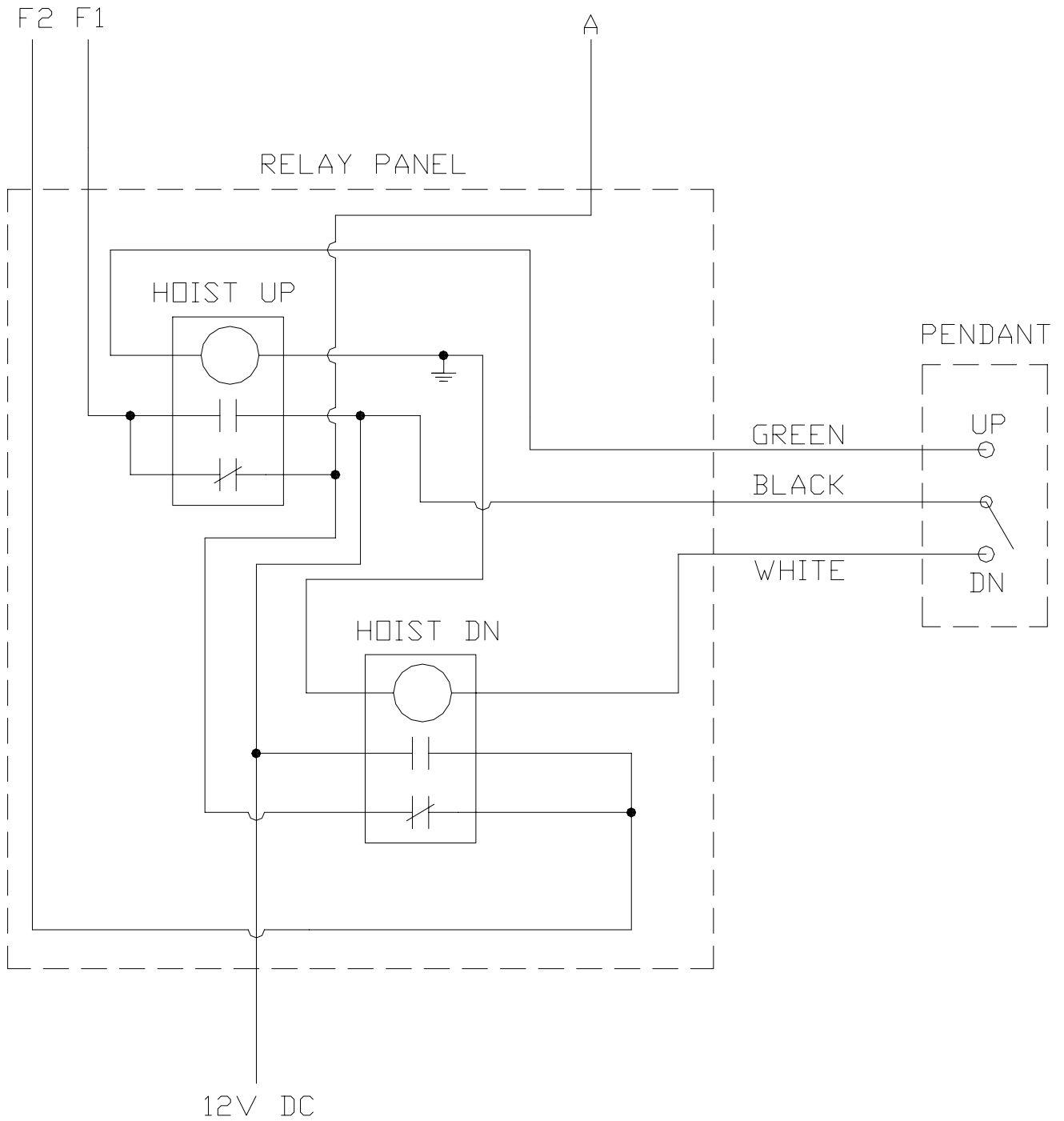

2003 LOAD CHART

P/N: 600938000

2003

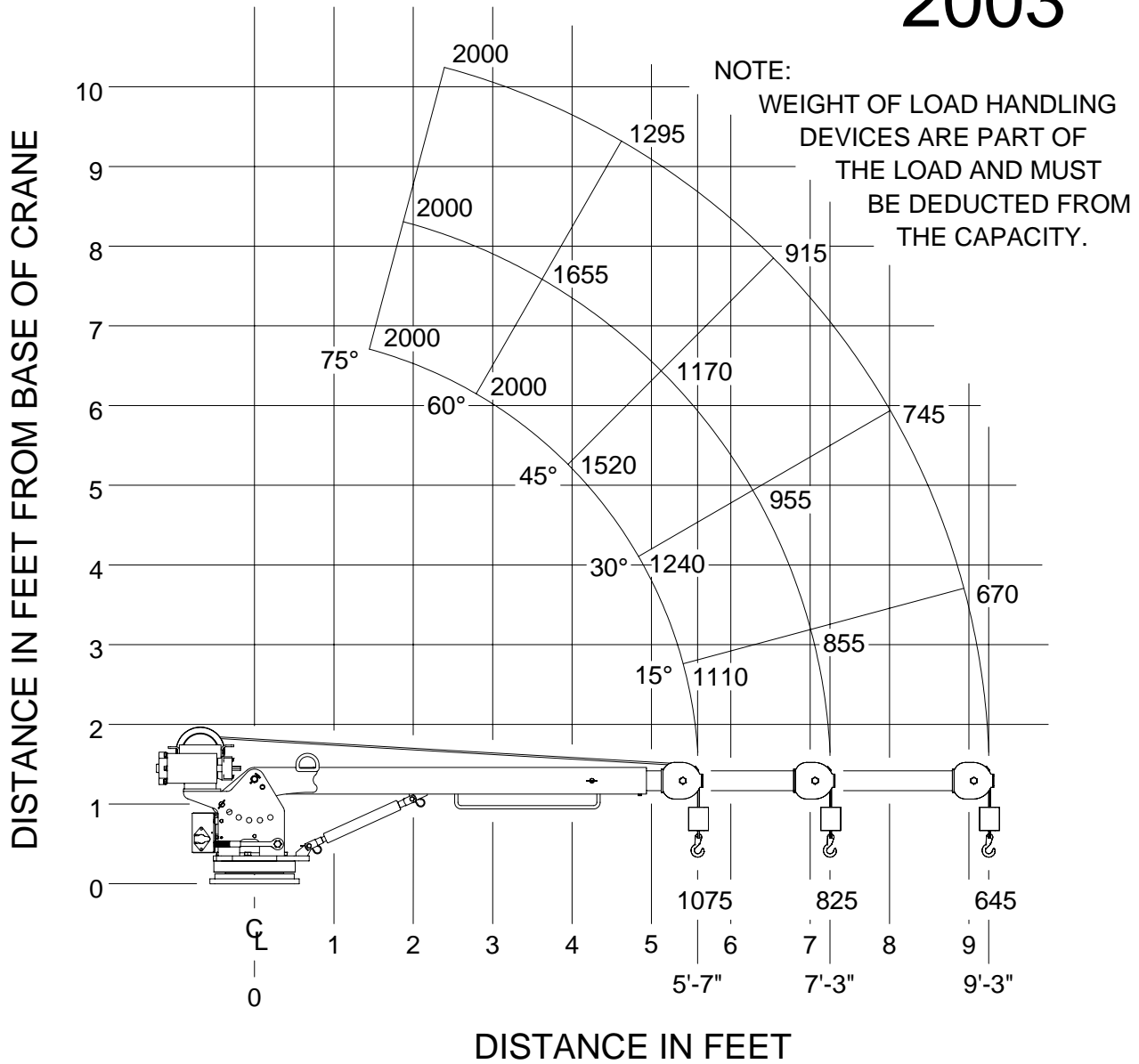

P/N 600938000 A



P.O. Box 580697 * Tulsa, OK 74158-0697
4707 N. Mingo Rd. * Phone (918) 836-0463

LIMITED WARRANTY 2 YEAR PARTS AND LABOR

Auto Crane will warranty to the consumer for a period of (2) years parts and labor from the date of purchase. Each new Auto Crane unit they sell will be free under normal use and service from defects in material and workmanship. Date of purchase will be honored as the date indicated on the Bill of Sale, which must accompany the Warranty Registration and be on file with Auto Crane. Absent a valid Warranty Registration and appropriate documentation, the original date of manufacture, as indicated by the serial number on the product, will be used to determine the effective date of the 2 year warranty.

The obligation of Auto Crane under this warranty is limited to the replacement or repair of parts that appear to the manufacturer after review and/or inspection to be defective and paid flat rate labor for replacing defective parts. This warranty does not obligate Auto Crane to bear the travel time charges in connection with the replacement or repair of defective parts. Responsibility for customer's claims arising from misapplication, abuse, misuse or alteration of equipment or parts lies with the distributor or user and no warranty obligation is assumed in these circumstances by Auto Crane.

Auto Crane will in no event be liable for any consequential damages or contingent liabilities arising out of the failure of any Auto Crane Product or parts to operate properly.

Auto Crane makes no warranty in respect to component accessories, it being subject to the warranties of their respective manufacturers.

If field service, at the request of the distributor, is rendered and fault is found not to be with Auto Crane's product, the distributor shall pay the time and expense of the field representative.

Claims for service labor or other expenses that have incurred by the buyer without approval or authorization or Auto Crane will not be accepted.

When applying for warranty, claims may be handled by contacting your nearest authorized Auto Crane Distributor. All claims are to be filed in writing on an Auto Crane Warranty Claim Form.

AUTO CRANE COMPANY IS UNDER NO OLIGATION TO EXTEND THIS WARRANTY TO ANY CUSTOMER FOR WHICH AN AUTO CRANE DELIVERY REPORT FORM HAS NOT BEEN COMPLETED AND ON FILE WITH AUTO CRANE COMPANY