



The new Titan™ crane body is engineered for the way you work, with enhanced safety performance, improved functionality, and an intuitive design to help you get the job done safer, faster, and more productively than ever.

The Titan features a truck-load of improvements that are second to none in the industry—from flush-mounted LED stop, tail and turn lights, to larger grab handles and highly visible lights on the bumper. What's more, the new interlocked channel design is even lighter and stronger, giving you additional payload.

The features you've asked for. The quality and performance you've come to expect.

The new Titan. Engineered for the way you work.



**Engineered First.  
Engineered to Last.**

**MADE IN THE USA**

## Introducing the New Titan™ Service Truck Work Body



### Ten Titan Advantages

- 1 Patented one-piece 10ga side-pack increases strength and durability
- 2 Interlocking frame reduces weight while increasing rigidity
- 3 Integrated crane box transfers load directly to outriggers – reducing stress on the chassis
- 4 Radius corners distribute stress from loading for maximum body life
- 5 Internal stainless steel hinges reduce potential corrosion points
- 6 Deep T-handles mounted flush to the door prevent catching or snagging
- 7 Extra-large grab handles for safe access even with gloved hands
- 8 Workbench bumper with large integrated step for maximum safety
- 9 Double-panel “slammable tailgate” for quick access from the ground
- 10 Flush-mount LED Stop-Tail-Turn lights for improved safety and visibility

## Chassis - Body - Crane Application

Make	Model	Body	Chassis											
			2003	3203 H	3203 EH	4004 EH	5005 H	5005 EH	6006 EH	6406H	8406H	10006H	14005H	
Ford	F250	n/a	X	X										
	F350	Titan 16	X	X	X									
	F450	Titan 38	X	X	X	X	X	X	X					
	F550	Titan 38	X	X	X	X	X	X	X					
	F650	Titan 50					X	X	X	X				
		Titan 60										X		
F750	Titan 60										X			
	Titan 70												X	
Dodge	Ram 2500	n/a	X	X										
	Ram 3500	Titan 16	X	X	X									
	Ram 4500	Titan 38	X	X	X	X	X	X	X					
	Ram 5500	Titan 38	X	X	X	X	X	X	X					
International	Terra Star	Titan 38	X	X	X	X	X	X	X					
	Dura Star 4100	Titan 38	X	X	X	X	X	X	X					
		Titan 50					X	X	X	X				
	Dura Star	Titan 60										X		
Titan 70													X	
Kenworth	T170	Titan 38	X	X	X	X	X	X	X					
	T270	Titan 50					X	X	X	X				
		Titan 60										X		
T370	Titan 70												X	
Freightliner	M2-106	Titan 38	X	X	X	X	X	X	X					
		Titan 50					X	X	X	X				
		Titan 60										X		
		Titan 70												X
		Titan 70												X
Peterbilt	330-335	Titan 70											X	
	340-389	Titan 70											X	
Crane		Titan 16	X	X	X									
		Titan 38	X	X	X	X	X	X	X					
		Titan 50					X	X	X	X				
		Titan 60										X		
		Titan 70												X

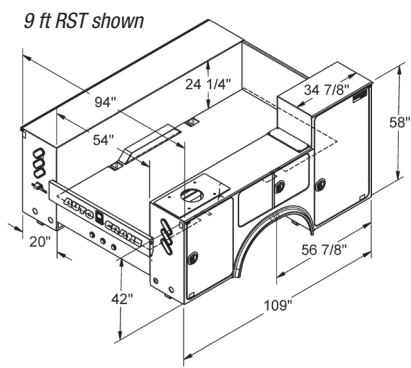

- Titan 16**  
Available in:
- 9 ft and 11 ft body lengths
  - Left Side Tall, Both Sides Tall, Both Sides Standard
  - Right Side Crane and Left Side Crane

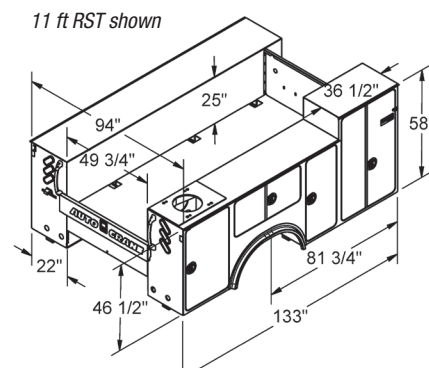

- Titan 38**  
Available in:
- 9 ft and 11 ft body lengths
  - Left Side Tall, Both Sides Tall, Both Sides Standard
  - Right Side Crane and Left Side Crane

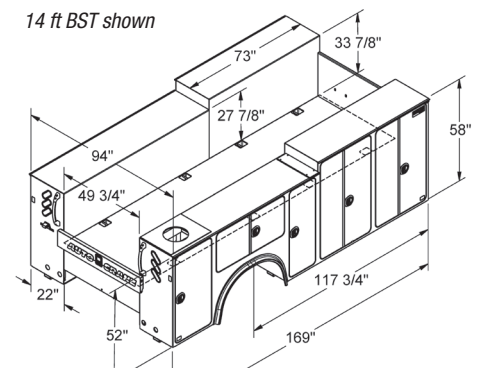

- Titan 50/60/70**  
Available in:
- 11 ft and 14 ft body lengths
  - 52 in & 58 in tall side-packs (11 ft bodies)
  - Both Sides Tall (14 ft bodies)
  - Right Side Crane and Left Side Crane

<p><b>TITAN CODE KEY</b></p> <p>RSC = Right Side Crane LSC = Left Side Crane</p>	<p>STD = Standard Tall (all sidepack compartments standard)</p> <p>RST = Right Side Tall (extra tall front compartment)</p> <p>LST = Left Side Tall (extra tall front compartment)</p> <p>BST = Both Sides Tall (extra tall front compartment)</p> <p>FLT = Full Length Tall (58" tall sidepacks)</p>	<p>CA = Cab to Axle Length</p> <p>60CA fits 9ft body lengths</p> <p>84CA fits 11ft body lengths</p> <p>120CA fits 14ft body lengths</p> <p>Other sizes available as custom</p>
--	---	--

Auto Crane® is a brand of Auto Crane Company, a wholly owned subsidiary of Ramsey Industries, Inc.  
Engineered to be the best, Auto Crane is committed to the ongoing improvement of its products.  
Auto Crane reserves the right to make changes to our products without notice.