



The Original Field Service Crane For More than a Half-Century

As the inventor of the original service crane, which revolutionized safety in equipment service, Auto Crane offers a comprehensive line of electric and hydraulic telescoping cranes to meet the needs of the heavy-equipment industry—whether it's mining, construction, energy, or other industries that require the ultimate in safety and reliability.

As the world innovator of ultimate crane safety, Auto Crane's NexStar™ crane control technology delivers unprecedented control right from the operator's hands and provides a virtual second shield of defense, preventing the operator from unsafe overload conditions even in the harshest environments.

Auto Crane continues to lead the service crane industry through safety-focused innovation and an entrepreneurial drive to solve problems.

We look forward to solving yours.



**Engineered First.
Engineered to Last.**

MADE IN THE USA

2003 Series

2,000 lb (907 kg) capacity @ 3 ft (0.94 m)
645 lb (293 kg) capacity @ 9 ft (2.8 m)



3203EH Series with NexStar™

3,200 lb (1,452 kg) capacity @ 3 ft (0.94 m)
650 lb (295 kg) capacity @ 15 ft (4.6 m)



4004EH Series with NexStar™

4,000 lb (1,814 kg) capacity @ 4 ft (1.2 m)
780 lb (355 kg) capacity @ 20 ft (6.1 m)



5005EH Series

5,000 lb (2,903 kg) capacity @ 5 ft (1.5 m)
1,225 lb (556 kg) capacity @ 20 ft (6.1 m)

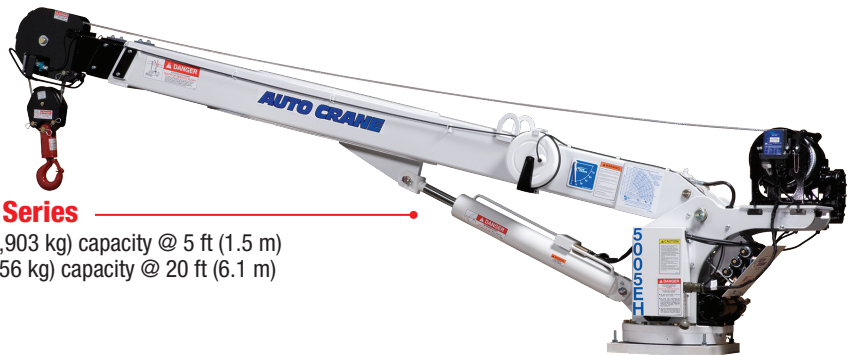

6006EH Series

6,000 lb (2,722 kg) capacity @ 6 ft (1.83 m)
1,770 lb (805 kg) capacity @ 20 ft (6.1 m)

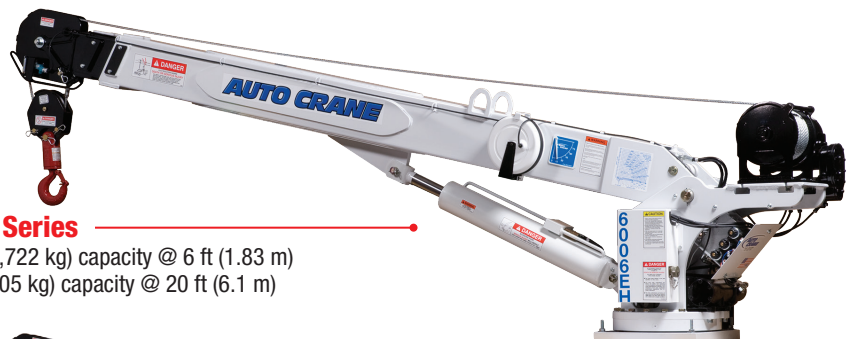

6406H Series with NexStar™

6,400 lb (2,903 kg) capacity @ 6 ft (1.83 m)
1,745 lb (793 kg) capacity @ 20.5 ft (6.3 m)



NexStar™

CRANE MANAGEMENT SYSTEM

- Crane Management System identifies the angle of the truck and the boom, preventing unsafe operation in unstable situations.
- Fully independent proportional control with multiple speed settings enables precise control over load placement.
- LCD display, status lights and audible alarm communicate critical information and diagnostics, keeping the operator informed and in control.

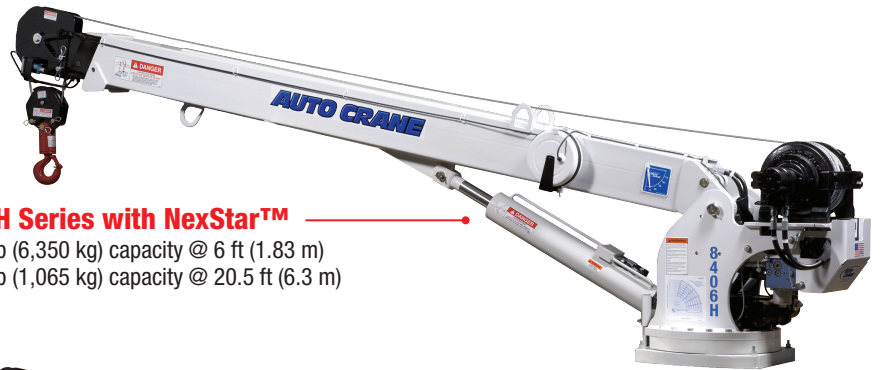

8406H Series with NexStar™
 8,400 lb (6,350 kg) capacity @ 6 ft (1.83 m)
 2,342 lb (1,065 kg) capacity @ 20.5 ft (6.3 m)



10006H Series with NexStar™
 10,000 lb (4,536 kg) capacity @ 6 ft (1.83 m)
 2,325 lb (1,057 kg) capacity @ 24.5 ft (7.5 m)

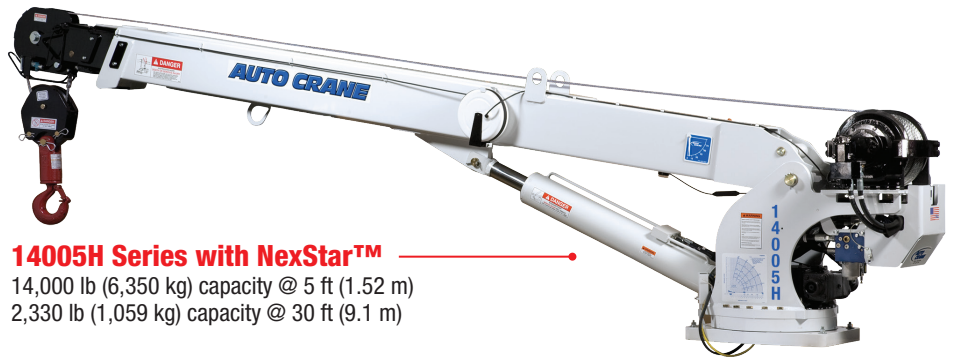

14005H Series with NexStar™
 14,000 lb (6,350 kg) capacity @ 5 ft (1.52 m)
 2,330 lb (1,059 kg) capacity @ 30 ft (9.1 m)

Model	Power Type	Crane Moment	Max Lift	Control Type	Max Reach	Hoist Type	Also Available
		Rating (ft-lb)	Capacity (Lb)				
Econoton II*	Electric	6,500	2,000	Non-Prop HW	5 ft / 7 ft	E	Tall / Short Pedestal Configurations
Econoton IIR*	Electric	6,500	2,000	Non-Prop HW	5 ft / 7 ft	E	Tall / Short Pedestal Configurations
2003	Electric	6,000	2,000	Non-Prop HW	9 ft	E / W	
3203EH	Elec./Hyd.	10,000	3,200	NexStar FM/Tethered	15 ft	H / P E / WG	Boom: Fully Manual / Mid Hydraulic / Fully Hydraulic Non-Proportional FM/HW Control Non-Proportional Electric Hoist
4004EH	Elec./Hyd.	16,000	4,000	NexStar FM/Tethered	16 ft / 20 ft	H / P E / WG	Non-Proportional FM/HW Control Non-Proportional Electric Hoist
5005EH	Elec./Hyd.	25,000	5,000	Non-Prop FM/HW	20 ft	E / WG	Continuous / Non-Continuous Rotation
6006EH	Elec./Hyd.	36,000	6,000	Non-Prop FM/HW	20 ft	E / WG	Continuous / Non-Continuous Rotation
3203H*	Hydraulic	10,000	3,200	Prop FM/HW	15 ft	H / WG	
5005H*	Hydraulic	25,000	5,000	NexStar FM	20 ft	H / P	Proportional HW Control
6406H	Hydraulic	38,000	6,400	NexStar FM	20 ft	H / P	Proportional HW Control
8406H	Hydraulic	50,000	8,400	NexStar FM	20 ft	H / P	Proportional HW Control
10006H	Hydraulic	60,000	10,000	NexStar FM	25 ft	H / P	Proportional HW Control
14006H	Hydraulic	70,000	14,000	NexStar FM	30 ft	H / P	Proportional HW Control

*Not pictured

E = Electric;
 E / WG = Electric/Worm Gear;
 H / P = Hydraulic/Planetary;
 H / WG = Hydraulic/Worm Gear; HW = Hardwired

Auto Crane® is a brand of Auto Crane Company, a wholly owned subsidiary of Ramsey Industries, Inc.

Engineered to be the best, Auto Crane is committed to the ongoing improvement of its products. Auto Crane reserves the right to make changes to our products without notice.