

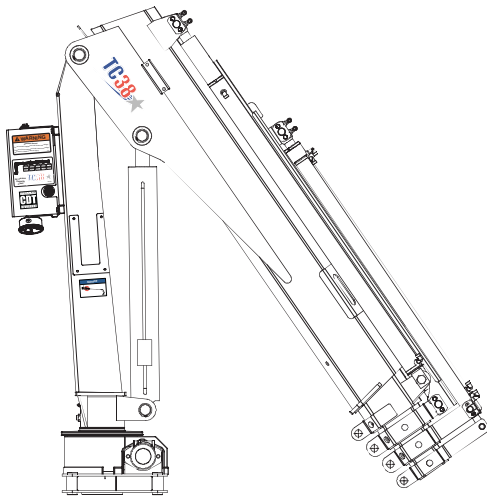

TC Series Telescopic Cranes Owner's Manual

Safety • Operation • Maintenance • Troubleshooting

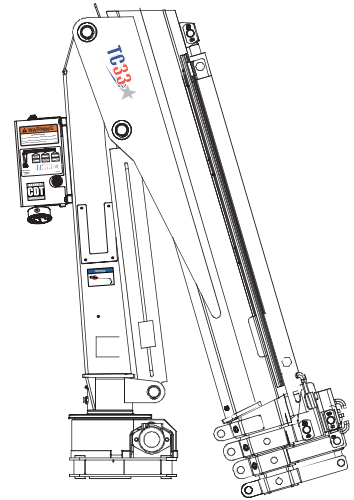
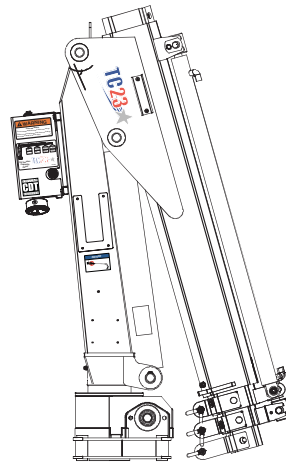
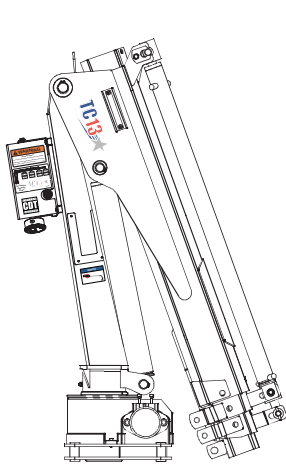

TC Series

Models:

TC13

TC23

TC33

TC38

Notice: A copy of this manual must remain with the equipment at all times.
For a printable download copy, please visit: www.stellarindustries.com

Stellar Industries, Inc.

190 State Street

PO Box 169

Garner, IA 50438

800-321-3741

Fax: 641-923-2811

www.stellarindustries.com

Subject to Change without Notification.
© 2017 Stellar Industries, Inc.

Last Revision: 2/14/17

TC Series Manual Revisions

Date of Revision	Section Revised	Description of Revision

For Technical Questions, Information, Parts, or Warranty, Call Toll-Free at

800-321-3741

Hours: Monday - Friday, 8:00 a.m. - 5:00 p.m. CST

Or email at the following addresses:

Technical Questions, and Information

service@stellarindustries.com

Order Parts

parts@stellarindustries.com

Warranty Information

warranty@stellarindustries.com

Table of Contents

Introduction.....	iv
Chapter 1 - Operation	1
General Operation.....	1
Pre-Operation Inspection	1
Job Site Setup	2
Step 1: Disengage drive axle and set the parking brake.....	2
Step 2: Engage the hydraulic power source.	2
Step 3: Turn on power to the crane.	2
Step 4: Position the stabilizers.	3
Step 5: Operate the crane.....	3
Step 6: Stow the crane.	5
Step 7: Stow the stabilizers.....	5
Step 8: Disengage the PTO and deactivate power.....	5
Step 9: Release the parking brake.	5
Radio Remote Control Functions.....	6
Radio Remote Feedback and Boost Mode.....	7
Boom Down Override Procedure	8
Radio Transmitter/Receiver Pair Procedure	8
Re-Link Radio and Receiver	8
Radio Remote Control Features	9
Safety Decals of Note	10
Mast - Valve Bank Cover.....	10
Chapter 2 - Maintenance.....	13
General Maintenance Guidelines	13
Basic Crane Maintenance Schedule*	13
Hydraulic Oil/Filter Maintenance.....	14
Washing the Crane	14
Paint Maintenance	14
PTO and Pump Maintenance	14
Extension Boom Maintenance.....	14
Load Hold Test Procedure	14
Lubrication Recommendations	15
Chapter 3 - Troubleshooting.....	17
Manual Operation	19

Introduction

Stellar® Cranes are designed to provide safe and dependable service for a variety of operations. With proper use and maintenance, these cranes will operate at peak performance for many years.

To promote this longevity, carefully study the information contained in this manual before putting the equipment into service. Though it is not intended to be a training manual for beginners, this manual should provide solid guidelines for the safe and proper usage of the crane.

Once you feel comfortable with the material contained in this manual, strive to exercise your knowledge as you safely operate and maintain the crane. This process is vital to the proper use of the unit.

A few notes on this manual:

A copy of this manual is provided with every crane and can be found in the hard plastic manual case that is installed on the chassis. A copy of this manual shall remain with the crane at all times.

Throughout the manual, three signal words will be used to bring attention to important items:

NOTICE

A NOTICE signal word indicates a practice not related to physical injury.

⚠ WARNING

A WARNING signal word indicates a hazardous situation which, if not avoided, could result in death or serious injury.

⚠ DANGER

A DANGER signal word indicates a hazardous situation which, if not avoided, will result in death or serious injury.

Information contained within this manual does not cover all maintenance, operating, or repair instructions pertinent to all possible situations. Please be aware that some sections of this manual contain information pertaining to Stellar® manufactured cranes in general and may or may not apply to your specific model.

This manual is not binding. Stellar Industries, Inc. reserves the right to change, at any time, any or all of the items, components, and parts deemed necessary for product improvement or commercial/production purposes. This right is kept with no requirement or obligation for immediate mandatory updating of this manual.

In closing:

If more information is required or technical assistance is needed, or if you feel that any part of this manual is unclear or incorrect, please contact the Stellar Customer Service Department by phone at 800-321-3741 or email at service@stellarindustries.com.

Chapter 1 - Operation

Safety should be the number one thought on every operator's mind. Three factors should exist for safe operation: a qualified operator, well-maintained equipment, and the proper use of this equipment.

This chapter contains information regarding the safety and operation of Stellar® manufactured Telescopic Cranes and should be read and understood completely by everyone working with or near the crane before putting the unit into operation.

⚠ WARNING Failure to follow operating, maintenance, or safety instructions can result in death or serious injury.

General Operation

It is the responsibility of the owner to instruct the operator in the safe operation of the equipment and to provide the operator with properly maintained equipment.

⚠ WARNING Stellar® Crane operators must conform to the qualifications specified in ANSI B30.5 - Chapter 5-3 Operation. Trainees or untrained persons shall be under the direct supervision of qualified persons.

Operators shall consult with the owner of the equipment regarding current safety regulations and required personal protective equipment.

Please take note that Stellar Industries, Inc. is not liable for accidents incurred by the crane because of non-fulfillment from the operator's side of current rules, laws, and regulations.

Pre-Operation Inspection

Before operating the equipment, make sure all regular maintenance has been performed. Each day, inspect the crane for all of the following:

- Vehicle for standard checks such as proper tire inflation and fluid levels.
- Parking brake operation.
- Hydraulic reservoir for proper oil level.
- Hoses and gearboxes for evidence of oil leaks.
- Crane controls for excessive wear, cleanliness and proper operation.
- Operational aids such as decals for placement and legibility.
- All securing hardware such as cotter pins, snap rings, hairpins, and pin keepers for proper installation.
- Crane hook and other loose parts for damage to structures or weld.
- Anti-two block switch for proper function.
- Wire rope for broken wires, extensive wear, distortion, and heat damage.
- All safety guards for proper installation.

Replace/repair as necessary prior to operation. For a more detailed checklist of scheduled inspection points, refer to the Stellar® Crane Inspection Log. This document is an essential guide for the daily, monthly, quarterly and annual inspection tasks that will help maintain the quality of your Stellar product.

Job Site Setup

Thoroughly plan the lift by understanding the work site area and your loads before positioning the vehicle. For a complete and detailed description of job site setup, please refer to the AEM Safety Manual (Form C-70-2). Consider the following:

- The vehicle should be positioned in an area free from bystanders and overhead obstructions. Use a signal person if necessary.
- **⚠ DANGER** Always maintain safe clearance from high voltage power lines in accordance with ANSI B30.5: 5-3.4.5 Operating Near Electric Power Lines. Death or serious injury will result from inadequate clearance if crane, load, or vehicle becomes electrically charged.
- Make certain that the vehicle is parked on stable, flat ground as close to the job as possible. The surface under the service truck must be able to support the weight of the machine and its load.
- Use wheel chocks if parking the vehicle on a slope.
- Always park the vehicle with the grade. If cross-grade parking is required, the load capacity must be decreased appropriately to mitigate tipping risk.
- **⚠ WARNING** Do not operate the crane during electrical storms.
- In dusty work areas, every effort must be taken to keep dust and sand out of the moving parts of the machinery.
- In high humidity work areas, keep parts as dry as possible and well lubricated.

Step 1: Disengage drive axle and set the parking brake.

The drive axle must be disengaged and the parking brake must be set before operating any of the equipment.

Step 2: Engage the hydraulic power source.

1. Make certain that the transmission is in neutral/park.
2. Engage the hydraulic power source. If using a PTO, consult the PTO manual for specific instructions if needed.

Note: Allow the hydraulic system oil to warm before operating any of the hydraulic equipment, especially during cold weather.

Step 3: Turn on power to the crane.

To initiate electrical power to the crane, activate the button labeled 'Main Power' on the control panel. The control panel is commonly mounted on the floor in the middle of the vehicle cab. Feel free to activate any other button functions needed for the job.

Step 4: Position the stabilizers.

Lower the stabilizer(s) using the hand crank located at the rear of the truck.

⚠ WARNING Keep clear of stabilizer legs during operation. Moving stabilizers can cause serious crushing injuries. Make certain that all personnel are clear of the stabilizer and the ground contact point before operating.

⚠ WARNING Do not raise the rear tires of the truck off the ground with the stabilizers. Confirm that the stabilizers are positioned on stable, flat ground and that the truck is as level as possible both front to rear and side to side. Use stabilizer pads to ensure the proper distribution of weight.

Step 5: Operate the crane.

Operators should have a firm understanding of ANSI B30.5 - Section 5-3.2 Operating Practices and AEM Safety Manual (Form C-70-2) prior to operating of the crane.

Using the Radio Remote:

To operate the crane using the radio remote control:

1. Activate and hold the desired toggle switch
2. While holding the toggle, gently pull the variable speed trigger until the crane begins to move. The speed of the crane will vary in direct correlation to how much or how little the trigger is engaged.



Note: The radio remote allows for simultaneous functions. With practice, it is possible to use more than one toggle at the same time (Extension Out/Winch Down for example).

Unstowing the Crane:

To unstow the crane and prepare it for a lift:

- Raise the boom high enough to clear the truck bed and any other obstructions from the chassis.
- Rotate the crane until it clears the side of the truck body.

Note: The radio remote allows for simultaneous functions. With practice, it is possible to use more than one toggle at the same time (Extension Out/Winch Down for example).

Attaching the load:

- Position the crane with the hook centered directly over the load to avoid side loading.

- Attach the load to the hook by means of slings or other approved devices.

⚠ WARNING Never use a sling bar or anything larger than the hook throat that could prevent the hook latch from closing. This would negate the safety feature.

Lifting the load:

Lift the load slightly off the ground to check the safety of the cargo. Consider the following:

- Make certain that the stabilizers are positioned on flat, stable ground.

⚠ WARNING Never exceed manufacturer's capacity charts and ratings. These ratings are based on the machine's hydraulic, mechanical, and structural design rather than stability.

- Never perform a lift that can induce a dynamic force greater than the capacity of the crane.

• It is the responsibility of the operator to know the weight of both the rigging and the handled load to avoid overloading the crane. Do not rely on the overload device to determine maximum rated loads. If the crane is picking more than the maximum rated load, the overload protection device may be malfunctioning. Discontinue use immediately and contact Stellar Customer Service for support.

⚠ WARNING Do not use a crane to lift personnel without factory approved lifting device.

- Do not attempt to lift fixed loads.

Moving the load:

Ensure that the load is secure and balanced within the sling before moving. Consider the following:

- Be sure that the crane is level and stable before moving the load.

• Always look for any changes to the surroundings since the job site setup. Be aware of any new or missed overhead obstructions (branches, power lines, etc) and bystanders. Use a signal person if necessary.

⚠ WARNING Never operate the crane with personnel under any part the boom or load. Do not extend or rotate a load over anyone. Never allow personnel to place themselves under any part of the boom or load.

⚠ WARNING Never leave a crane load suspended or unattended.

- Do not use the boom to drag a load.
- Do not use the crane boom to push downward onto anything.
- Avoid sudden starts and stops when moving a load.

Step 6: Stow the crane.

Once you have performed your lift and are ready to shut down the work site:

- Retract all extensions.
- Rotate the crane until it aligns with the stowed position.
- Lower the boom gently into the stored position.
- Store the radio remote control, preferably in the cab of the truck.

Step 7: Stow the stabilizers.

After stowing the crane, return to the stabilizer crank and fully retract the stabilizer(s).

Step 8: Disengage the PTO and deactivate power.

- Depress the clutch on manual transmission vehicles.
- Disengage the PTO. Consult the PTO manual for specific instructions if needed.
- Slowly release the clutch on a manual transmission vehicle. Note: Make sure the PTO indicator light turns off.
- Turn off all switches on the control panel.

Step 9: Release the parking brake.

The parking brake must be released before moving the truck.

⚠ WARNING Make certain that any air tanks are completely drained before moving the truck.

Radio Remote Control Functions



- A. Optional Speed Control/Compressor Start/Stop Toggle:** Push up to start or stop the optional speed control. Push down to start or stop the compressor.
- B. E-Stop Button:** Push to immediately stop all crane functionality. Note: The E-stop button is not intended to be an on/off switch. This is also the first item to check if the crane is not responding to toggle and trigger activation. Make sure the red E-Stop button is in the up or disengaged position.
- C. Engine Start/Stop Toggle:** Push to start or stop the engine.
- D. Link/Boost Button:** Push and hold for 5 seconds to engage boost mode (See the following page for details on 'Boost Mode'). If the remote loses connection with the transmitter, use this button to reconnect.
- E. Boom Up/Down Toggle:** Push up to raise the boom. Push down to lower the boom.
- F. Extension In/Out Toggle:** Push up to extend the extension. Push down to retract the extension.
- G. Optional**
- H. Rotate Clockwise/Counterclockwise:** Push up to rotate the boom clockwise. Push down to rotate the boom counterclockwise.

Radio Remote Feedback and Boost Mode

CDT Remote Feedback

If the crane starts to approach full capacity or an overload situation, the Stellar CDT sensory feedback system will respond:

0-79% Capacity

LEDs: Green Steady

Vibration: None

System Function: Normal



80-89% Capacity

LEDs: Green Steady, Yellow Flashing

Vibration: Short Pulsing

System Function: Normal



90-99% Capacity

LEDs: Green Steady, Yellow and Red Flashing

Vibration: Long Pulsing

System Function: Normal



100% Capacity

LEDs: Green Steady, Yellow and Red Alternate Flashing

Vibration:

Long Pulsing

System Function:

Overload Shutdown.



When the crane reaches 100% capacity, an overload shutdown will be initiated. The operator will need to set the load down and reposition the truck or activate the Stellar CDT Boost Mode (If equipped).

Activating Boost Mode (If applicable)

Boost Mode allows the crane to operate at 118% of its rated capacity for 30 seconds. This will give the operator adequate time to move the crane out of the shutdown condition without having to set the load down and reposition the truck.

Follow the steps below to activate boost mode:

1. Press and hold the Link/Boost Button for 5 seconds. This button is located on the right side of the handheld controller. You will know that boost mode is activated by an indicator light located near the boost/link button.
2. The crane will go from the 'standard mode' to 'boost mode' for 30 seconds.
3. During this minute, the capacity of the crane is increased to 118% of standard capacity.

Note: Boost Mode can be reset multiple times after a 15 second delay.

See the troubleshooting section of this manual for information regarding troubleshooting the Stellar® CDT Remote System.

NOTICE

If the 118% capacity boost is not enough to temporarily suspend the overload shutdown, the operator will need to set the load down and reposition the truck.

Boom Down Override Procedure

One of the safety features of the TC series crane is to disable the boom down function when there is an overload condition. However, a false overload condition can occur when the boom up cylinder is fully extended. The control system is designed to allow the operator to override this false overload condition. Push the "boost" button on the radio until the boost light illuminates. The operator will then have 30 seconds to boom down.

Radio Transmitter/Receiver Pair Procedure

With both the transmitter and receiver powered up, press and hold the star logo button (A) on the receiver, and then simultaneously press and hold the "boost" button (B) on the transmitter for a two seconds. You may hear a relay click inside the receiver and the "RF Signal" indicator will start flashing. Press the "boost" button on the transmitter one more time to close the main contact relay and complete the pair/learn procedure.

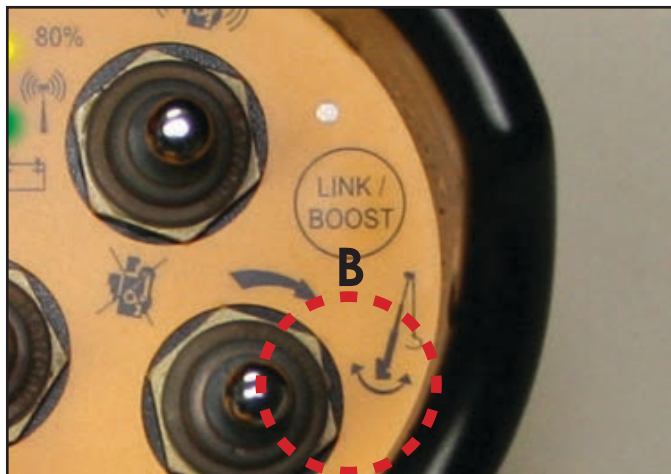

First, press and hold the star logo button (A) on the receiver, and then simultaneously press and hold the "boost" button (B) on the transmitter for a two seconds.

Re-Link Radio and Receiver

If the radio transmitter and receiver become disconnected from one another, push the Link /Boost Button for two seconds to re-link the two devices.

Radio Remote Control Features

Radio Remote Sleep Mode

The radio remote control enters sleep mode after two minutes of inactivity. Activate a toggle switch to re-link the transmitter to the receiver. After re-linking, activate the desired toggle to continue operation.

E-Stop Button

The Radio remote control is equipped with an emergency stop button. If a situation arises that requires the immediate stoppage of crane functionality, press down on the red Emergency Stop button located on the top of the remote control. To resume operation, activate any function to restart the transmitter.

Power on Demand Mode (P.O.D)

When the optional engine speed control is toggled on, the crane controller will automatically ramp the engine speed up to high idle while the crane is actively being operated. During periods of inactivity the engine speed will be returned to low idle. See the Installation, Assembly Drawings, and Parts Manual for mode selection wiring.

Radio Remote Battery Replacement

Occasionally the batteries in the handheld transmitter will need to be changed. The AA Alkaline batteries are located in the handle portion of the radio transmitter. Release the button and slide the battery holder out. Replace the batteries and return the holder back into the handheld transmitter until the button latches.



Magnet

A single magnet is integrated into the back housing of the radio remote. This magnet allows you to temporarily attach the radio to metal surfaces for your convenience.

Radio Remote Backup Cord

If the handheld transmitter has a system problem that makes the radio function un-usable, use of the back-up cord may be necessary.

⚠ DANGER Death or serious injury will result from touching tethered remote if the crane, load, or vehicle becomes electrically charged. Always maintain safe clearance from high voltage power sources.

1. Locate the backup control cord. Most likely it is in the crane compartment, or in the cab behind the seat.

2. Remove the battery holder from the remote handle and place the similar looking end of the back-up cord in the bottom of the transmitter handle.



3. Attach the other end of the back-up cord to the connector currently used by the antenna on the control receiver. The control receiver is located on the back of the crane mast.



Safety Decals of Note

Safety decals serve to inform the viewer of the hazard type, how to avoid the hazard, and the consequences of not avoiding the hazard.

Decals are considered safety equipment. They must be maintained, as would other safety devices. All safety instruction plates, notices, capacity charts and any other decal applied to the crane or service body must be kept legible and in good condition. Replace any decals that are missing, damaged, or illegible.

Detailed below are a number of key safety decals related to this equipment. Use the decal placement drawing in the Installation, Assembly Drawings, and Parts Manual to note the actual location of the safety decals on the equipment.

Mast - Valve Bank Cover

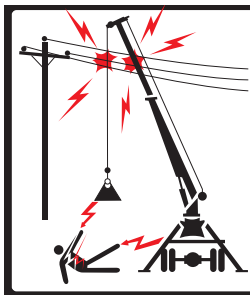

⚠ DANGER
Electrocution Hazard
 Death or serious injury will result from inadequate clearance if crane, load, or vehicle becomes electrically charged.

- Maintain safe clearance from high voltage power sources.
- Never approach vehicle or load if equipment is near a high voltage power source.

77735

Decal Part Number: 77735
Decal Location: On mast valve bank cover
Hazard Type: Electrocution Hazard
Consequences: Will result in death or serious injury.
Avoidance: Maintain safe clearance from high voltage power sources. Never approach vehicle or load if equipment is near a high voltage power source.

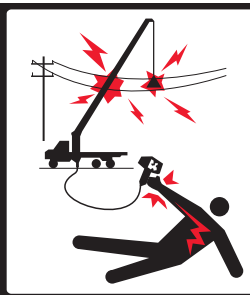

⚠ DANGER
Electrocution Hazard
 Death or serious injury will result from touching tethered remote if crane, load, or vehicle becomes electrically charged.

Maintain safe clearance from high voltage power sources.

78078

Decal Part Number: 78078
Decal Location: On mast valve bank cover
Hazard Type: Electrocution Hazard
Consequences: Will result in death or serious injury.
Avoidance: Maintain safe clearance from high voltage power sources.

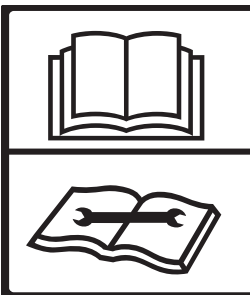

⚠ WARNING
Untrained Operator Hazard
 Read and understand all manuals and safety signs before operating or servicing this equipment.

Failure to follow operating, maintenance, or safety instructions can result in death or serious injury.

77734

Decal Part Number: 77734
Decal Location: On mast valve bank cover
Hazard Type: Untrained Operator Hazard
Consequences: Can result in death or serious injury.
Avoidance: Read and understand all manuals and safety signs before operating or servicing equipment.



⚠ WARNING
Fall Hazard
 Hoisting personnel on boom, hook, load, or loadline can result in death or serious injury.

- Never use crane to hoist personnel.
- Never ride the boom, hook, load, or any device attached to crane boom or load line.

77733

Decal Part Number: 77733
Decal Location: On mast valve bank cover
Hazard Type: Fall Hazard
Consequences: Can result in death or serious injury.
Avoidance: Never use the crane to hoist personnel. Never ride the boom, hook, load, or any device attached to the crane boom or load line.

Mast - Valve Bank Cover Continued...



! WARNING

Free Falling Boom Hazard

Free falling manual boom extensions can result in death or serious injury.

- Properly install retention pins prior to operation.
- Do not stand in front of extension when removing retention pin.
- Do not allow extensions to free fall.

78079

Decal Part Number: 12452

Decal Location: On mast valve bank cover

Hazard Type: Free Falling Boom Hazard

Consequences: Can result in death or serious injury.

Avoidance: Properly install retention pins prior to operation. Do not stand in front of extension when removing retention pin. Do not allow extensions to free fall.

! WARNING

Movement Hazard

After stowing the crane, always return the valve bank manual overrides to the neutral position.

Failure to return the manual overrides to the neutral position can result in death or serious injury.

25159

Decal Part Number: 25159

Decal Location: On mast valve bank cover

Hazard Type: Movement Hazard

Consequences: Can result in death or serious injury.

Avoidance: After stowing the crane, always return the valve bank manual overrides to the neutral position.

! WARNING

Overload Hazard

Do not exceed equipment load charts and ratings.

Failure to follow equipment load charts and ratings can result in death or serious injury.

4189

Decal Part Number: 4189

Decal Location: On mast valve bank cover

Hazard Type: Movement Hazard

Consequences: Can result in death or serious injury.

Avoidance: Do not exceed equipment capacity charts and ratings.

This page intentionally left blank.

Chapter 2 - Maintenance

Maintenance is an important part of extending the life of any Stellar® Telescopic Crane. Performing key maintenance items on a scheduled program will prevent unnecessary downtime.

General Maintenance Guidelines

Before performing any maintenance to the crane, consider the following:

- **⚠️ WARNING** Only qualified service personnel are to perform maintenance on the crane. Never modify or alter any of the equipment, whether mechanical, electrical, or hydraulic, without explicit approval from Stellar Industries.
- Position the crane where it will be out of the way of other operations or vehicles in the area.
- Lower the boom fully or stow in the cradle to prevent uncontrolled movement.
- Place all controls in the off position and secure operating features from inadvertent motion. Follow all company directed lockout/tagout procedures.
- Before any service or repair is performed, disengage the hydraulic power source and shut off the engine.
- Allow systems to cool before performing any maintenance.
- Before performing any maintenance on electrical components, disconnect the power source.
- Before performing any maintenance on hydraulic components, relieve hydraulic oil pressure from all hydraulic circuits. Move pedals and control levers repeatedly through their operating positions to relieve all pressures.
- **⚠️ WARNING** Do not disconnect hydraulic hoses while there is still pressure in those components.
- Replace parts with Stellar® approved parts only.
- Keep the crane and service body clean and free from grease build-up, oil and dirt to prevent slippery conditions.
- Label or tag parts when disassembling.
- Immediately repair or have repaired any components found to be inadequate.

Basic Crane Maintenance Schedule*

Maintenance Operation	Daily	Weekly	Monthly	Hourly
Check hydraulic reservoir oil level.	X			
Grease rotation gear inner race bearings.		X		
Grease rotation gear worm drive bearings.			3 months	
Grease rotation gear open gear teeth.			X	
Grease all cylinder pivot points.			X	
Lubricate extension booms.			X	
Drain and replace hydraulic oil.				6500
Tighten all hydraulic lines.			6 months	

* For a more detailed outline of scheduled inspection points, refer to the Stellar® Crane Inspection Log. The Stellar® Crane Inspection Log is an essential guide for the daily, monthly, quarterly and annual inspection tasks that will help maintain the quality of your Stellar product.

Hydraulic Oil/Filter Maintenance

Stellar Industries recommends the first filter change to occur after the first 250 hours of service. The second, and every subsequent change, should occur after every 1,000 hours of service. By following these guidelines, the hydraulic oil should last up to 6,500 hours.

Note: These recommendations are based on normal working parameters. If operating in less than favorable conditions (excessive dust, moisture, etc.), be sure to check the filter gauge often for filter change notice.

Washing the Crane

Important: Prior to washing the Stellar crane, all electrical components must be covered to prevent any water from being injected into the plastic housing. Avoid any direct water pressure to any of the electrical components.

Paint Maintenance

Touch up any chips or scratches to prevent further paint damage.

PTO and Pump Maintenance

Every six (6) months, remove the hydraulic pump from the PTO and lubricate the splines using Stellar PN 20885. Failure to lubricate shaft splines will cause damage to the PTO and Hydraulic pump.

Extension Boom Maintenance

While operating the crane, extend and retract the extension booms. If the extension weldments are noisy during operation, it is necessary to lubricate the booms. Stellar® Model Cranes feature a metal coating which will require an aerosol lubricant. Stellar Industries recommends aerosol style lubricant Stellar PN 44512.

Load Hold Test Procedure

Fully extend a load (65-70% of crane's rated capacity) at a boom angle of approximately 60°. With the load at 3-5 inches off the ground, use a tape measure to mark the load from a specific flat/level spot on the ground (Note: Use a board/pad if necessary). Also at this time, use a grease pen to make a temporary mark on the main cylinder rod and another mark on the winch drum in reference to the housing. Finally, measure the stabilizer legs from the ground.

After waiting five minutes, measure the load from the same specific spot on the ground. If the load movement is within 1/4", the test has passed. If the load has moved more than 1/4", wait another five minutes and re-measure. If the load continues to move, check the other marks (main cylinder rod, winch drum) and re-measure the stabilizers to narrow down the potential drifting issue. Please refer to the troubleshooting section at the end of this manual for further detailed instructions.

Lubrication Recommendations

Crane Lubrication

Component	Location	Recommendation
Hydraulic System	Reservoir	
	Below -5°F	High VI, low pour, ISO 22, AW hydraulic oil
	-5°F to 90°F	High VI, low pour, ISO 32, AW hydraulic oil
	Above 90°F	ISO 46, AW hydraulic oil
Open Gear Teeth	Crane Rotation Gear	Moly Grease 936SF Heavy (Stellar PN 4460)
Worm Drive Bearings (including turntable bearing inner race)	Crane Rotation Gear, Inside Crane Compartment	EP2 Lithium Complex Grease (Stellar PN 78090)
Cylinders	Crane Pivot Areas	EP2 Lithium Complex Grease (Stellar PN 78090)
Crane Pins & Bushings	Crane Pivot Points	EP2 Lithium Complex Grease (Stellar PN 78090)
Wear Pad Lubrication	Extension Booms	Synthetic lubricant containing Teflon®

Compressor Lubrication

Component	Location	Recommendation
Reciprocating Single Stage	Compressor Crankcase	ISO 100 compressor oil
Reciprocating Double Stage	Compressor Crankcase	ISO 100 compressor oil
Screw Compressor	Compressor Crankcase	
	-15°F to 86°F	Synthetic performing ISO 32 compressor oil
	-23°F to 100°F	Synthetic performing ISO 46 compressor oil
	32°F to 113°F	Synthetic performing ISO 68 compressor oil

This page intentionally left blank.

Chapter 3 - Troubleshooting

This chapter will list a number of potential problems that may occur while operating the crane. Most problems are easily solved using the solutions portion of this chapter. If problems persist, please contact Customer Service at Stellar Industries 1-800-321-3741.

Serial Tag Location

STELLAR[®] DATE _____

PATENT INFORMATION
<http://www.stellarindustries.com/ip>

MODEL NO. SERIAL NO.

MADE IN THE U.S.A. BY STELLAR INDUSTRIES, INC.
PN C5942

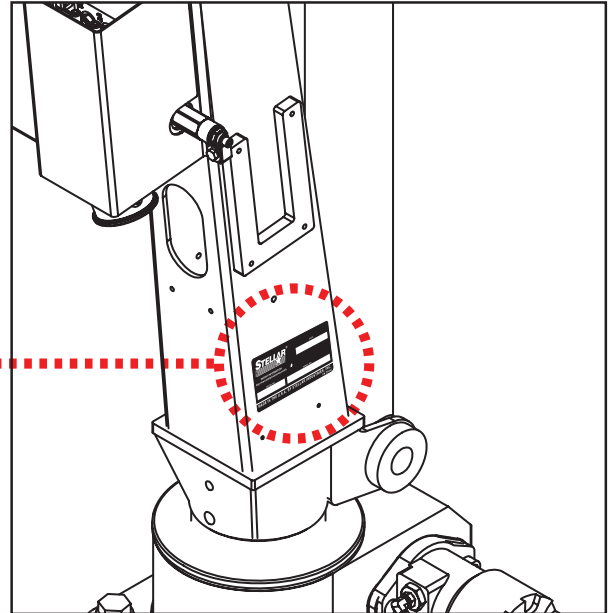

Prior to troubleshooting:

Always make sure the parking brake is engaged and the PTO is engaged (if equipped).

To determine if there is an electrical or hydraulic problem, first try to operate the crane manually. This is done by turning the manual override knob on the flow valve, then operating the individual solenoid valves located along the valve bank. If the crane operates, there will be an electrical problem to trace. If the crane does not operate using the manual overrides, there is a problem within the hydraulic circuit.

Problem: Crane will not operate.

Solutions:

- Make sure that the parking brake is engaged.
- Make sure that the PTO is engaged.
- Make sure that there is 12V power going to the radio receiver. If there is no power going to the receiver, trace back to the power source and check for a blown fuse or loose ground connection. Refer to radio remote troubleshooting guide at the end of this chapter.
- Make sure that the transmitter batteries are fully charged.
- Make sure that the hydraulic pump is operating at its rated flow or GPMs. Check the flow by using the flow meter to determine the GPMs. It is possible that the hydraulic pump is getting weak. If this is suspected, contact Stellar Customer Service.

Problem: Crane will operate manually but will not operate by radio remote.

Solutions:

- Make sure that there is 12V power going to the radio receiver. If there is no power going to

the receiver, trace back to the power source and check for a blown fuse or loose ground connection. Refer to radio remote troubleshooting guide at the end of this chapter.

- Make sure that the parking brake is engaged.
- Make sure that the parking brake switch is working properly. Check the parking brake switch by performing a continuity test. If the switch is defective, simply replace it.

Problem: Not all crane functions operate using the radio remote transmitter or crane operates intermittently.

Solutions:

- Make sure that the toggle switch is working properly. If the switch is defective, simply replace it.
- Make sure that there is power going to the valve bank coil solenoid of the function that will not operate. If no power is going to the coil solenoid, check wiring connections on wire harness plug connector for broken wires, loose connection or poor crimp. If power is going to the solenoid valve, it may not be opening to allow hydraulic oil to the function that is not operating. Remove stem valve, thoroughly clean, lubricate, and reinstall valve. Do not over tighten. If the valve will not close, simply replace it.

Problem: Two functions operate at the same time while only toggling one function.

Solutions:

- Make sure that the solenoid valves are all latched in the center position to ensure that they do not move while operating the crane.
- Determine the function that is operating on its own. Check to see if there is power going to the solenoid valve from a function that should not be operating. If voltage is present at the solenoid valve without operating the function, the toggle switch has failed and is stuck in the “on” function. If no voltage is present, the solenoid valve may be partially open. Remove the stem valve, thoroughly clean, lubricate, and reinstall the valve. Do not over tighten. If valve will not close, simply replace it.

Problem: Crane only operates at full speed.

Solutions:

- Check to see if there is 12V power constantly going to the proportional valve. If 12 volts are showing up at the proportional valve without pulling on the transmitter trigger, the handle/trigger assembly may be defective. If 8 volts are showing at the proportional valve, it is possible that the valve is stuck open and will not close. Remove the valve, clean it thoroughly and reinstall. Do not over tighten. If the problem persists, replace the proportional valve.
- Check to see if the manual override on the proportional valve is turned out. Turn the manual override on the flow valve in (7621 thru 12630 models only).

Problem: Crane operates slowly.

Solutions:

- Make sure that the crane is receiving the recommended hydraulic flow to operate.
- Check the level of hydraulic fluid in the reservoir. Add fluid as needed.
- Check hydraulic fluid temperature.
- Check to see if the valve bank orifice is plugged. If so, replace the orifice. Call Stellar Customer Service for instructions.
- Make sure the proportional valve is receiving 12V power when fully engaging the transmitter trigger. If there is not 12V power while pulling the trigger, check for loose connections inside the transmitter or replace the handle trigger assembly. If the proportional valve is receiving 12 volts, loosen the solenoid holding nut and check to

see if the solenoid coil is magnetizing. If no polarity is present, replace the coil. If coil is magnetizing, remove the stem valve, thoroughly clean, lubricate, and reinstall the valve.

Problem: Cylinder drifts outward or downward.

Solutions:

- Check to see if there is air in the hydraulic system. Operate all cylinders connected to the hydraulic system. Start with the extension cylinder, then operate the main boom, winch, rotation, and ending with the hydraulic stabilizers, if installed. When operating, extend each cylinder halfway out, retract all the way in, and then extend until the cylinder rod is at the end of its stroke. Operate cylinders slowly so air is pushed thru the system to the reservoir. Repeat this cycle 2-3 times.
- Make sure the holding valves are operating properly. Note: Before performing any maintenance on hydraulic components, relieve hydraulic oil pressure from all hydraulic circuits. Remove, clean, and then inspect each holding valve. When removing a holding valve, always relieve the pressure inside the cylinder by loosening jam nut of the holding valve and turning set screw inward/clockwise. Count the number of turns until the set screw is seated. When reinstalling the holding valve, make sure the valve is reset by turning the set screw the number of turns it took to relieve the pressure. Finish by tightening the jam nut.
- Check the cylinder rod for scratches. If a scratch is located on the cylinder rod, hydraulic fluid can pass thru and cause a loss of pressure. Replace cylinder rod or cylinder.
- Check to see if the piston seals are damaged. If they show signs of damage, install a new cylinder seal kit.

Manual Operation

If the remote control malfunctions, follow these steps to operate the crane manually:

- 1. Activate Flow Control.** Turn the override screw on proportional flow control counter-clockwise. Full adjustment is between three and five turns.
- 2. Operate Solenoids.** Using the identification decal as a guide, slide the knurled sleeve out and then push or pull to operate the desired function. Be sure the sleeve is in the center, locked, position before returning to remote operation.
- 3. Deactivate Flow Control.** Turn the override screw clockwise until stopped. Full adjustment is between 3 and 5 turns.
- 4. Return the valve bank manual overrides to the neutral position.**

⚠ WARNING Failure to return the valve bank manual overrides to the neutral position can result in unexpected crane movement.

- 5. Have the unit serviced immediately to restore remote control functionality.**

