

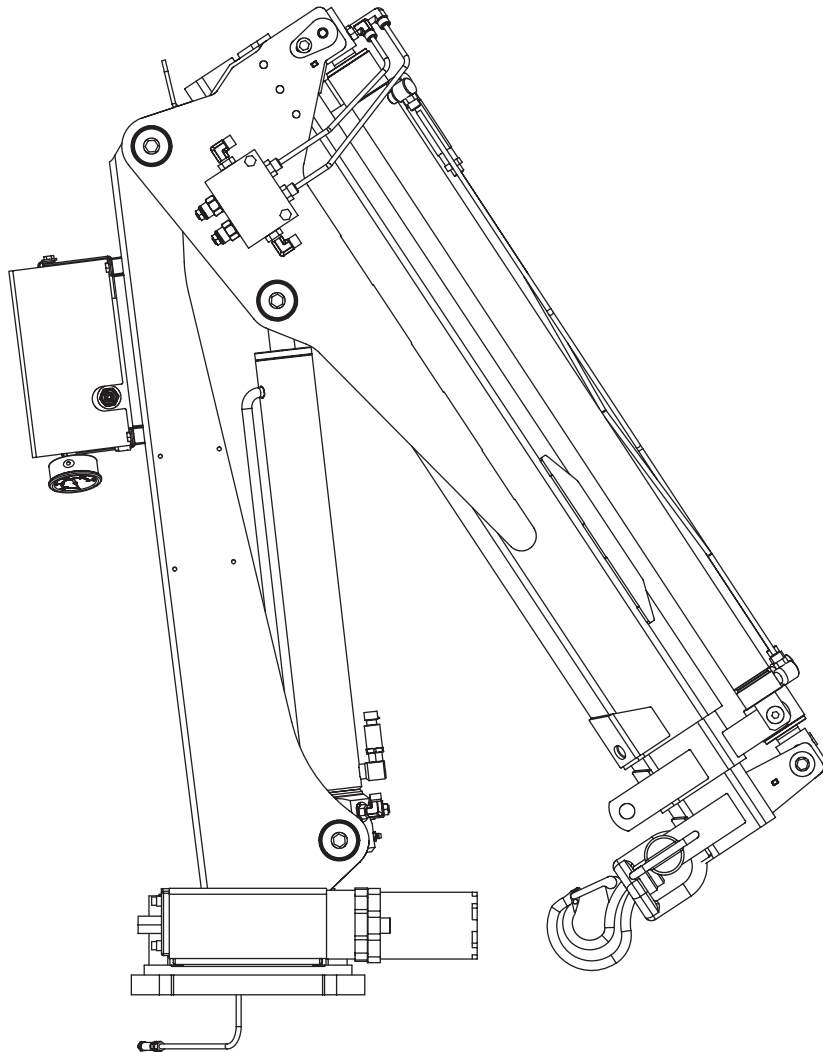

# Model TC13 Telescopic Crane Owner's Manual

Installation • Assembly Drawings • Parts



**Notice:** A copy of this manual must remain with the equipment at all times.  
For a printable download copy, please visit: [www.stellarindustries.com](http://www.stellarindustries.com)

**Stellar Industries, Inc.**

**190 State Street**

**PO Box 169**

**Garner, IA 50438**

**800-321-3741**

**Fax: 641-923-2811**

**[www.stellarindustries.com](http://www.stellarindustries.com)**

# Model TC13 Manual Revisions

Date of Revision	Section Revised	Description of Revision

## Serial Tag Location

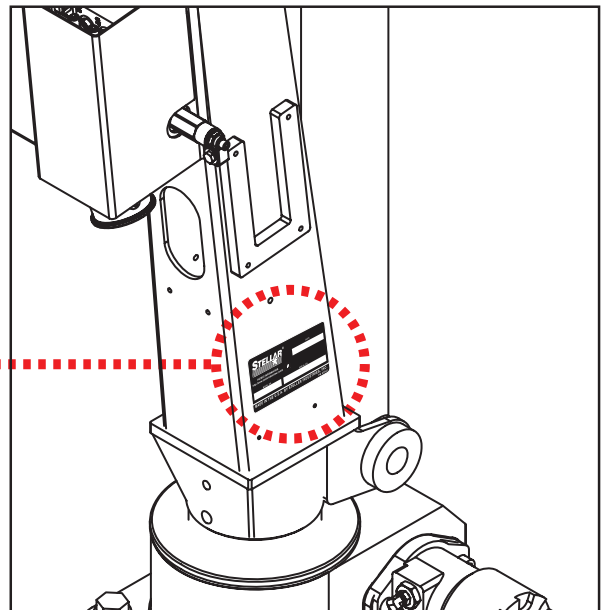
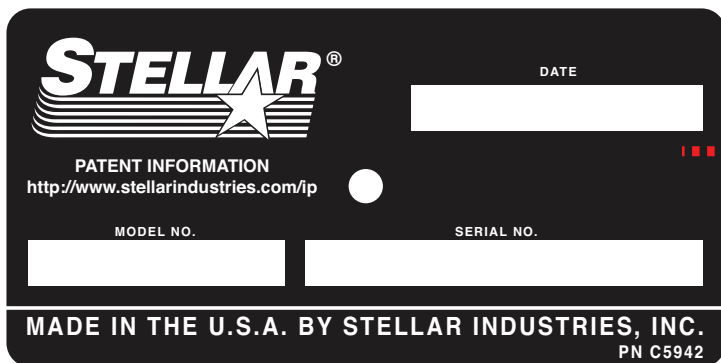

# Table of Contents

---

Introduction.....	iv
<b>Chapter 1 - Specifications.....</b>	<b>1</b>
Model TC13 Specifications .....	1
Model TC13 w/ Winch Specifications .....	2
TC13 Capacity .....	3
<b>Chapter 2 - Installation .....</b>	<b>5</b>
General Installation .....	5
Installer Notice .....	5
Torque Data Chart .....	6
Installation Overview .....	7
TC13 Mounting Detail.....	7
TC13 Installation Drawing - PN 90459 .....	8
Flatbed Body Reinforcement.....	8
Control Kit - PN 96174.....	9
Control Kit Installation Drawing - PN 96175.....	10
Control Kit with Winch Installation Drawing - PN 96175.....	11
TC Series Wiring Diagram.....	12
Hydraulic Kit - PN 96494 .....	13
Hydraulic Kit w/ Winch - PN 96495.....	14
TC13 Hydraulic Schematic .....	15
Hydraulic Kit Installation Drawing - PN 90469 .....	16
Hyd. Kit w/ Winch Installation Drawing - PN 94137 .....	17
Optional Power Unit Assembly - PN 77897 .....	18
Face Seal/O-Ring Size Chart.....	19
Stability Procedure .....	20
Crane Load Level Indicator.....	21
Decal Placement - PN 76875 .....	22
<b>Chapter 3 - Assembly Drawings .....</b>	<b>23</b>
Base Assembly - PN 88695 .....	23
Gear Bearing Assembly - PN 41640 .....	24
Mast Assembly - PN 88884.....	25
Boom Assembly - PN 88944 .....	26
Boom Bill - PN 88944 .....	27
Boom w/ Winch Assembly - PN 92671 .....	28
Boom w/ Winch Bill - PN 92671 .....	29
Winch Kit Assembly - PN 75172 .....	30
Winch Kit Bill - PN 75172.....	31

# Introduction

A copy of this manual is provided with every crane and can be found in the hard plastic manual case that is installed on the chassis. A copy of this manual shall remain with the crane at all times.

Throughout the manual, three signal words will be used to bring attention to important items:

## **NOTICE**

A NOTICE signal word indicates a practice not related to physical injury.

## **⚠ WARNING**

A WARNING signal word indicates a hazardous situation which, if not avoided, could result in death or serious injury.

## **⚠ DANGER**

A DANGER signal word indicates a hazardous situation which, if not avoided, will result in death or serious injury.

Information contained within this manual does not cover operation, maintenance, or troubleshooting. Please refer to the General Light Duty Crane Manual for details on these items.

This manual is not binding. Stellar Industries, Inc. reserves the right to change, at any time, any or all of the items, components, and parts deemed necessary for product improvement or commercial/production purposes. This right is kept with no requirement or obligation for immediate mandatory updating of this manual.

In closing:

If more information is required or technical assistance is needed, or if you feel that any part of this manual is unclear or incorrect, please contact the Stellar Customer Service Department by phone at 800-321-3741 or email at [service@stellarindustries.com](mailto:service@stellarindustries.com).

**For Technical Questions, Information, Parts, or Warranty, Call Toll-Free at  
800-321-3741**

Hours: Monday - Friday, 8:00 a.m. - 5:00 p.m. CST

Or email at the following addresses:

**Technical Questions, and Information**

[service@stellarindustries.com](mailto:service@stellarindustries.com)

**Order Parts**

[parts@stellarindustries.com](mailto:parts@stellarindustries.com)

**Warranty Information**

[warranty@stellarindustries.com](mailto:warranty@stellarindustries.com)

# Chapter 1 - Specifications

## Model TC13 Specifications

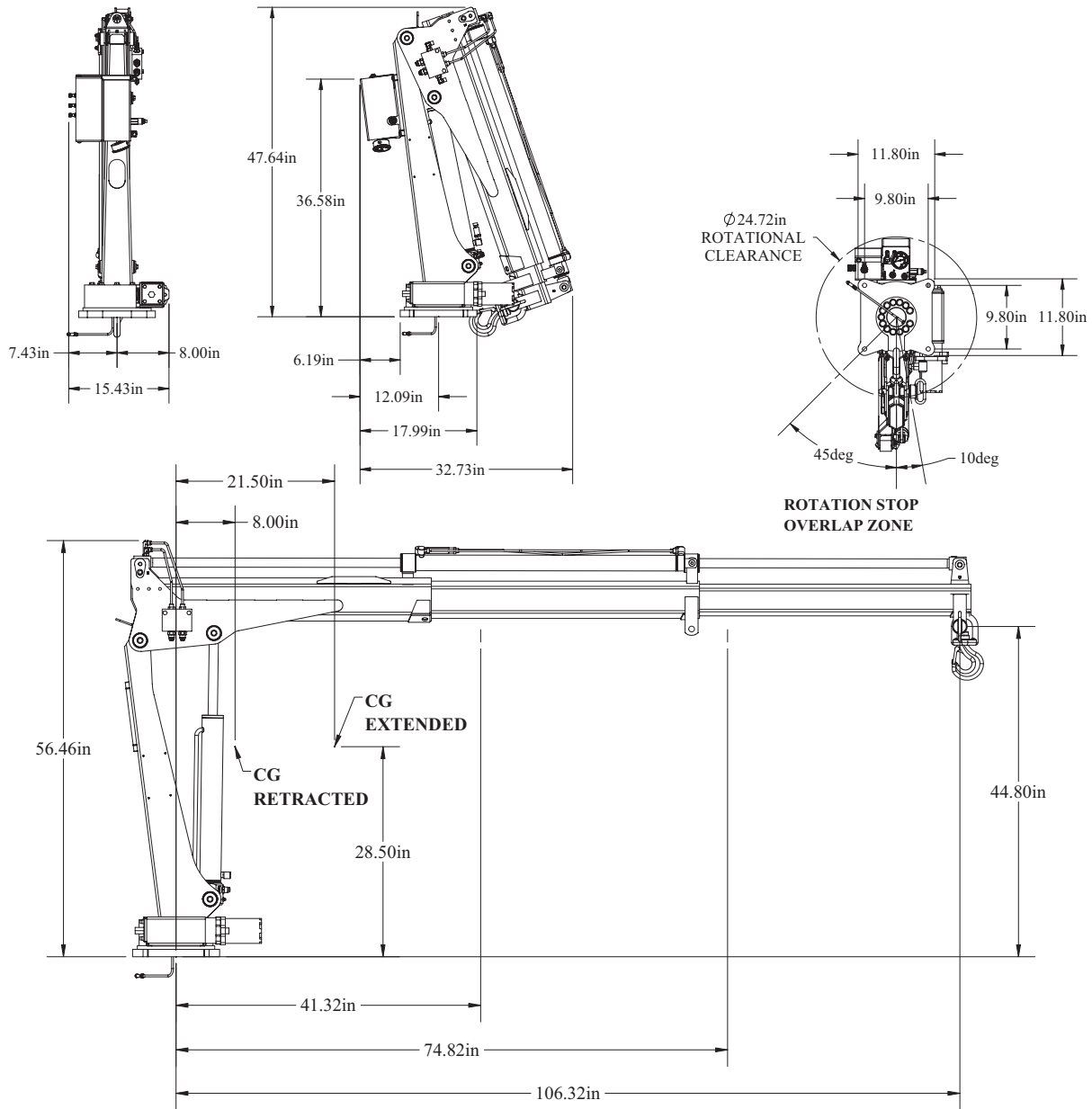

TC13 Crane	
Crane Rating:	8,600 ft.lbs (11.66 kNm)
Max Lifting Capacity:	2,400 lbs (1,090 kg)
Max Reach:	8.86 ft (2.7 m)
Slewing Angle:	410°
Operating Pressure:	2,755 psi 19.0 Mpa (190 bar)
Pump Capacity:	2.5 gpm (9.5 lpm)
Shipping Weight:	370 lbs (168 kg)

# Model TC13 w/ Winch Specifications

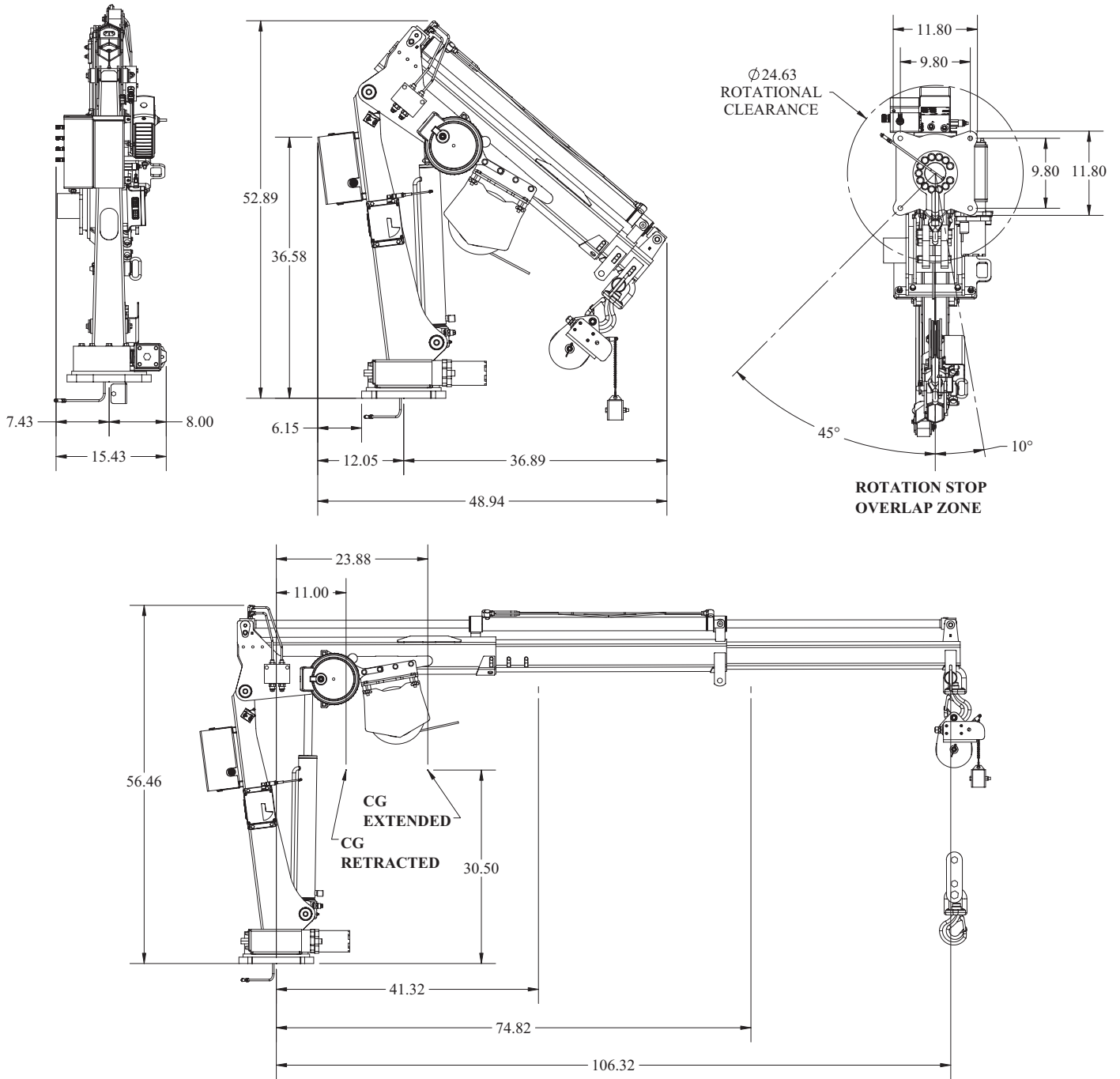

## TC13 Crane w/ Winch

Crane Rating:	8,600 ft.lbs (11.66 kNm)
Max Lifting Capacity:	1,600 lbs (725 kg)
Max Reach:	8.86 ft (2.7 m)
Slewing Angle:	410°
Operating Pressure:	2,755 psi 19.0 Mpa (190 bar)
Pump Capacity:	2.5 gpm (9.5 lpm)
Shipping Weight:	545 lbs (247 kg)
Wire Rope:	1/4" (0.63 cm) 7X19 GAC X 65' (19.81 m)

# TC13 Capacity

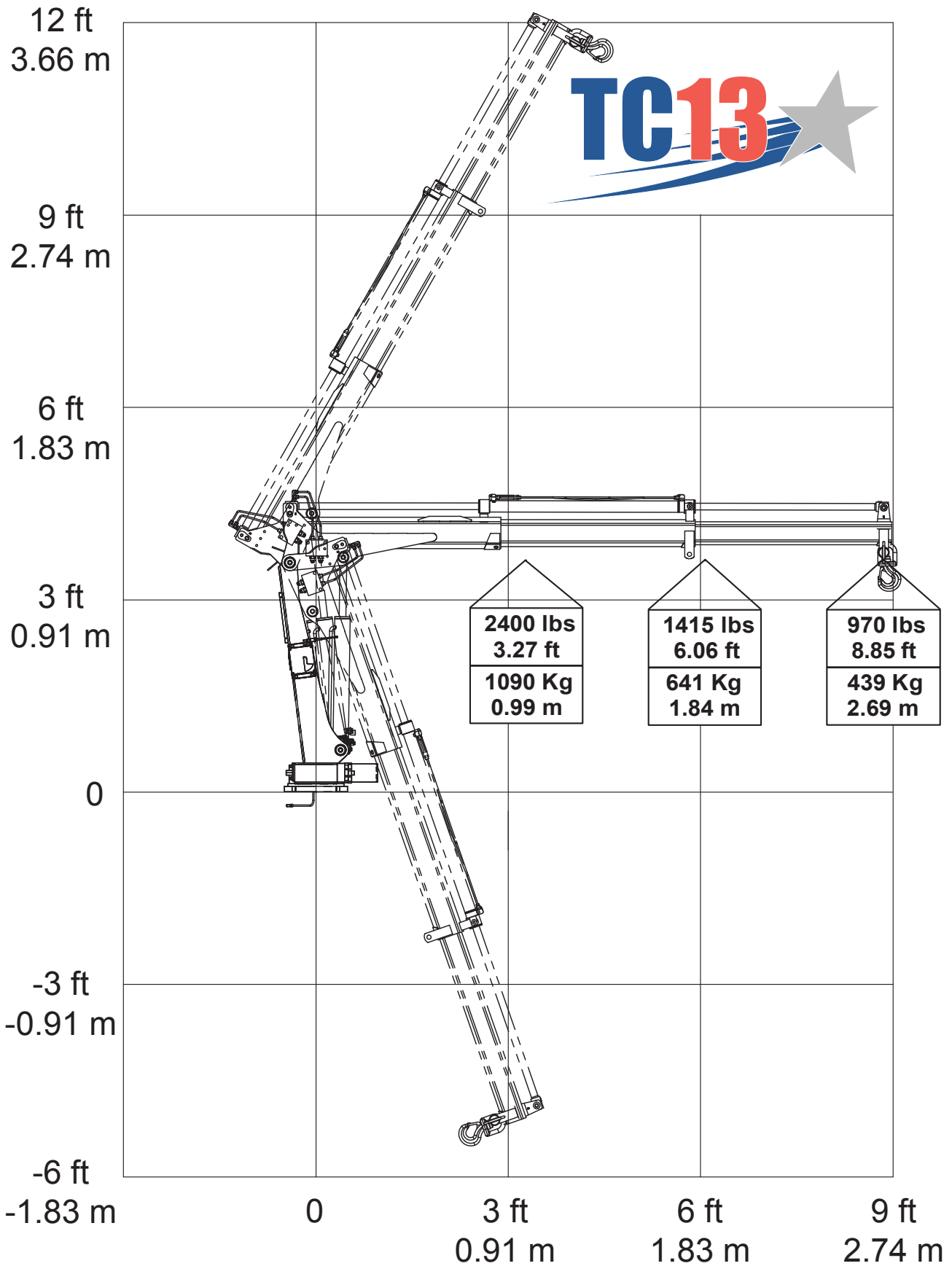

**This page intentionally left blank.**



# Chapter 2 - Installation

## General Installation

This chapter is designed to serve as a general guide for the installation of a Stellar TC13 Crane on a Stellar Service Body. Each installation is considered unique so certain portions of this chapter may or may not apply to your direct application. If a question should arise during the installation process, please contact Stellar Customer Service at (800) 321 3741.

This crane is designed for use with a Stellar Service Body installed on a vehicle that meets the minimum chassis requirements of the crane. It is the installer's responsibility to assure that the crane is mounted on a platform that will support the maximum crane rating of this crane.

**⚠ WARNING** Do not install this crane on a body not capable of handling the loads imposed on it. Failure to do so may result in serious injury or death.

**NOTICE** When installing welder units to the service bodies, it is highly recommended that a surge protector is installed on the chassis batteries to protect the crane radio receiver, wiring and other electronic devices from an unexpected electrical spike or surge. Failure to do so could result in extensive damage to the service body and crane electrical circuit.

## Installer Notice

According to Federal Law (49 cfr part 571), each final-stage manufacturer shall complete the vehicle in such a manner that it conforms to the standards in effect on the date of manufacture of the incomplete vehicle, the date of final completion, or a date between those two dates. This requirement shall, however, be superseded by any conflicting provisions of a standard that applies by its terms to vehicles manufactured in two or more stages.

Therefore, the installer of Stellar® Cranes and Bodies is considered one of the manufacturers of the vehicle. As such a manufacturer, the installer is responsible for compliance with all applicable federal and state regulations. They are required to certify that the vehicle is in compliance with the Federal Motor Vehicle Safety Standards and other regulations issued under the National Traffic and Motor Vehicle Safety Act.

Please reference the Code of Federal Regulations, title 49 - Transportation, Volume 5 (400-999), for further information, or visit <http://www.gpoaccess.gov/nara/index.html> for the full text of Code of Federal Regulations.

## Torque Data Chart

When using the torque data in the chart, the following rules should be observed:

- Bolt manufacturer's particular specifications should be consulted when provided.

- Flat washers of equal strength must be used.

- All torque measurements are given in foot-pounds. To convert to inch-pounds, multiply by 12.

- Torque values specified are for bolts with residual oils or no special lubricants applied. If special lubricants of high stress ability, such as Never-Seez compound graphite and oil, molybdenum disulphite, colloidal copper or white lead are applied, multiply the torque values in the charts by the factor .90. The use of Loctite does not affect the torque values listed above.

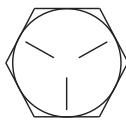
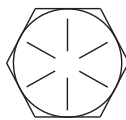
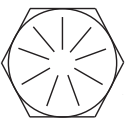
		GRADE 5		GRADE 8		GRADE 9
						
Size (DIA-TPI)	Bolt DIA (Inches)	Plain (Ft-Lb)	Plated (Ft-Lb)	Plain (Ft-Lb)	Plated (Ft-Lb)	Plated (Ft-Lb)
5/16-18	0.3125	17	13	25	18	22
3/8-16	0.3750	31	23	44	33	39
7/16-14	0.4375	49	37	70	52	63
1/2-13	0.5000	75	57	105	80	96
9/16-12	0.5625	110	82	155	115	139
5/8-11	0.6250	150	115	220	160	192
3/4-10	0.7500	265	200	375	280	340
7/8-9	0.8750	395	295	605	455	549
1-8	1.000	590	445	910	680	823
1 1/8-7	1.1250	795	595	1290	965	1167
1 1/4-7	1.2500	1120	840	1815	1360	1646
1 3/8-6	1.3750	1470	1100	2380	1780	2158
1 1/2-6	1.500	1950	1460	3160	2370	2865

- Torque values for socket-head capscrews are the same as for Grade 8 capscrews.
- Do not use these values if a different torque value or tightening procedure is given for a specific application. Torque values listed are for general use only. Check tightness of fasteners periodically.
- Shear bolts are designed to fail under predetermined loads. Always replace shear bolts with identical grade.
- Fasteners should be replaced with the same or higher grade. If higher grade fasteners are used, these should only be tightened to the strength of the original.
- Tighten plastic insert or crimped steel-type lock nuts to approximately 110 percent of the dry torque values shown in the chart below, applied to the nut, not to the bolt head. Tighten toothed or serrated-type lock nuts to the full torque value. *Note: "Lubricated" means coated with a lubricant such as engine oil, or fasteners with phosphate and oil coatings. "Dry" means plain or zinc plated without lubrication. Tighten lubricated bolts to approximately 80% of dry bolts.*

## Installation Overview

1. Use the dimensional specifications to properly size and position the crane for mounting.
2. Use the detail on the following page to drill .82" diameter holes into the mounting plate.
3. Use a crane or lifting device capable of lifting the weight of the TC13 (See specifications for shipping weight details).
4. Connect straps or chain from the lifting device to the main boom of the TC13.
5. Remove motor to allow installation of the mounting bolts.
6. Use four (4) 0.75-10 UNC Grade 8 bolts, washers, and nuts. (See install drawing for details)
7. Using the lifting device, lower the TC13 just above the mounting surface and start the bolts. Have someone assist in leveling the crane.
8. Secure the crane using the mounting hardware provided. Note: longer or shorter bolts may be required – recommended thread engagement into crane base is 0.75" – use grade 8, zinc plated bolts only.
9. Torque the bolts to proper torque.
10. Remove supporting crane.
11. Hook up hydraulics and electrical using the schematics provided later in this chapter.

## TC13 Mounting Detail

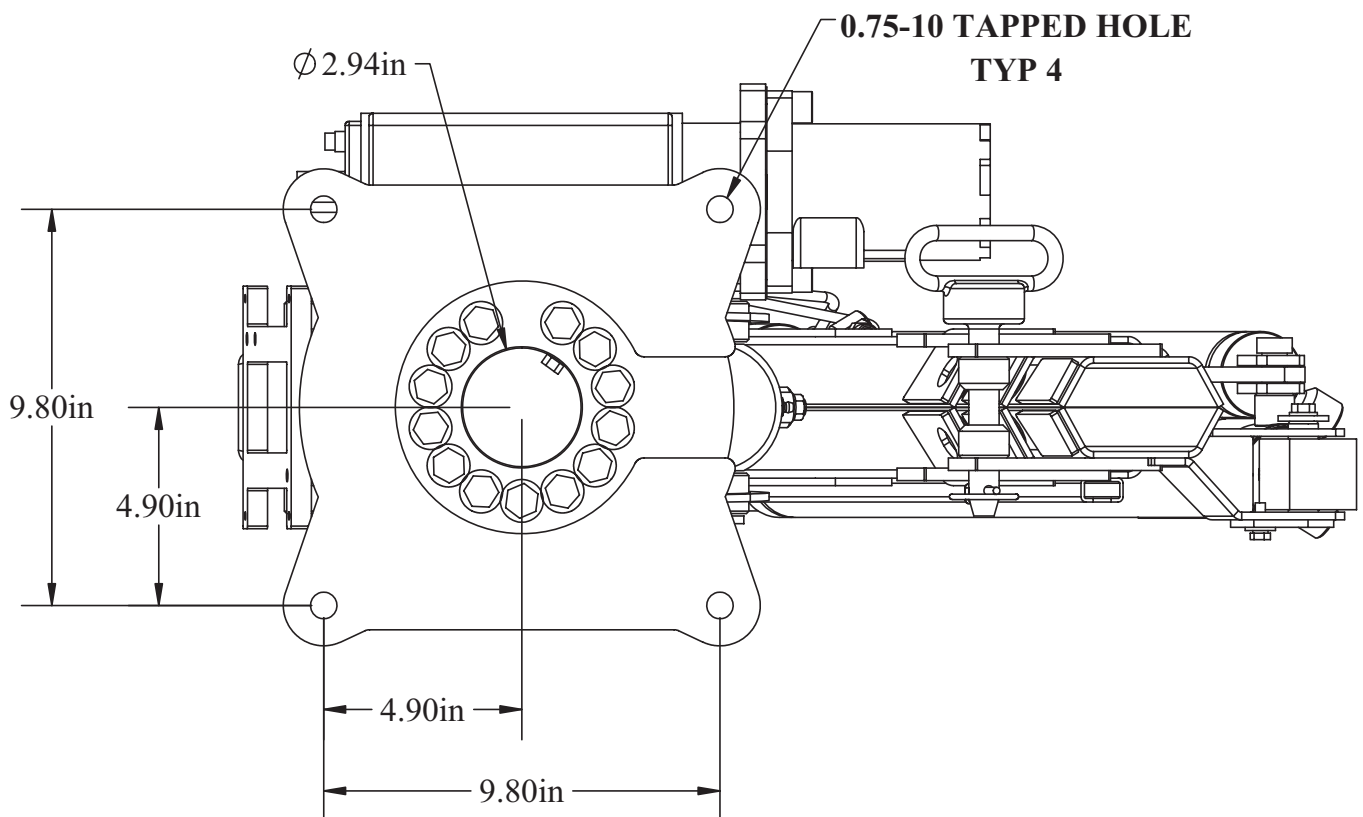

# TC13 Installation Drawing - PN 90459

**USE 0.75-10 UNC GRADE 8 BOLTS, WASHERS, & NUTS**  
NOTE: LENGTH NOT SPECIFIED DUE TO VARYING MOUNTING REQUIREMENTS

**PN 90459**

ITEM	PART	DESCRIPTION	QTY.
1	C5942	PLATE SERIAL # TRUCK (NOT SHOWN)	1
2	8176	SCREW DRIVE #4X0.31 RND HD U ZINC	1

**NOT SHOWN:**  
DECAL KIT 76875  
LEVEL 76483  
MANUAL KIT 76364

## Flatbed Body Reinforcement

If it has been determined that the destination body won't support the crane with a fully rated load, the body must be reinforced. Use 1/4" fillet welds and an AWS qualified welder to proceed as shown in this drawing:

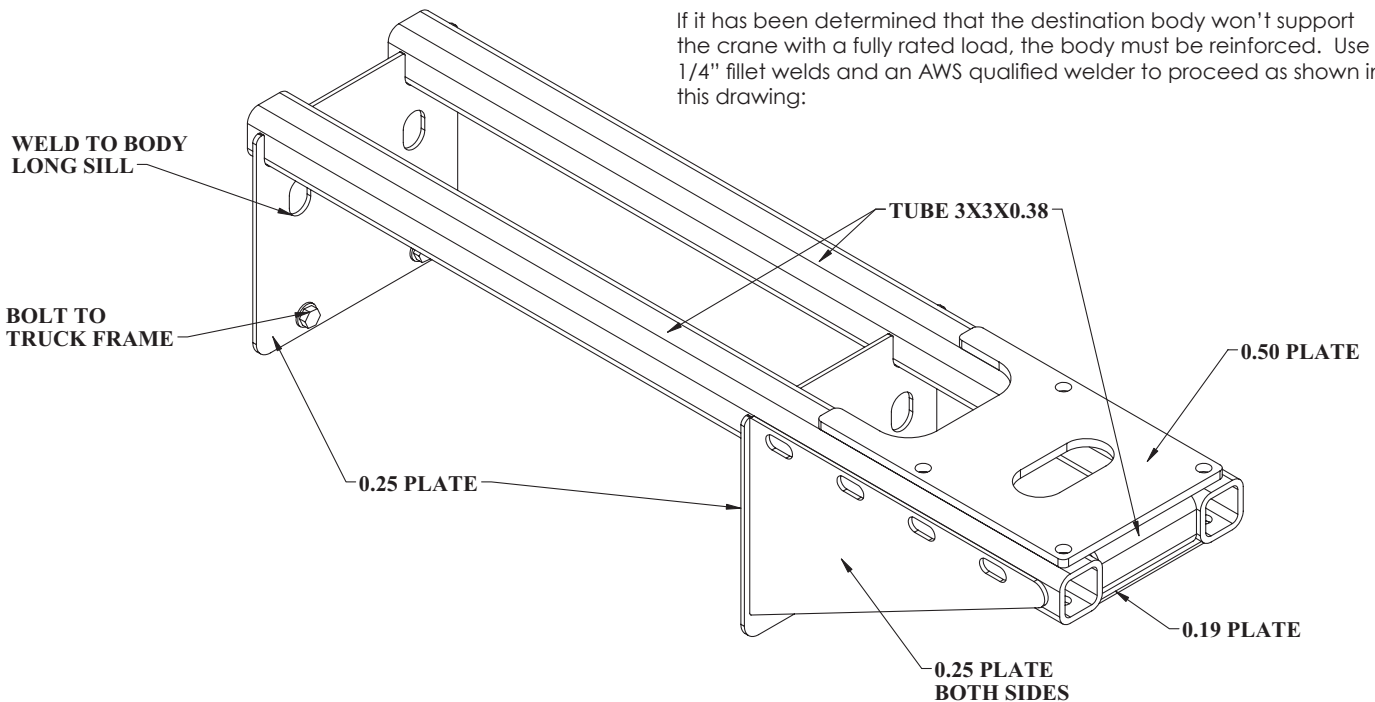

# Control Kit - PN 96174

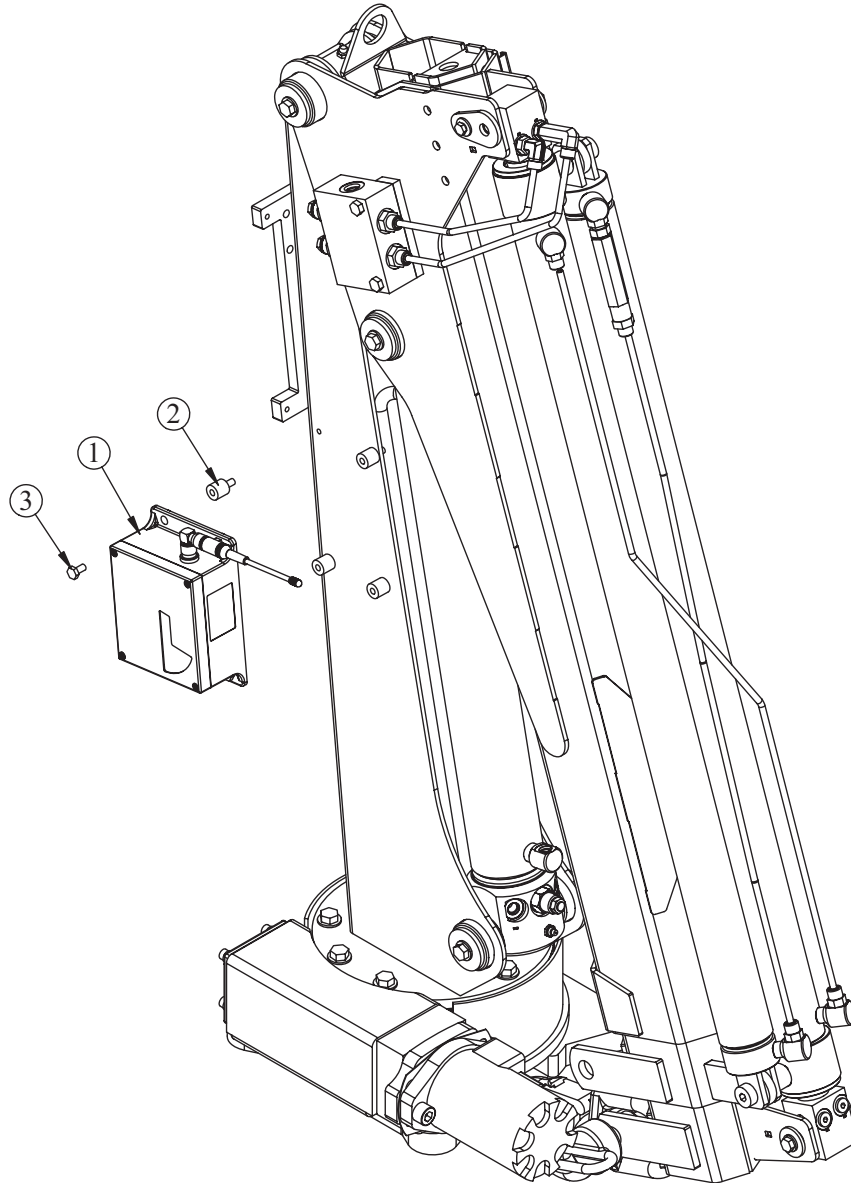

## PN 96174

ITEM	PART	DESCRIPTION	QTY.
1	96172	RADIO CTRL ASM 7 FCTN CDT TC CRANES V3	1
2	76554	ISOLATOR RUBBER 0.25-20X1.13	4
3	0478	CAP SCR 0.25-20X0.50 HHGR5	4

**NOT SHOWN:  
WIRE HARNESS 76678  
BACKUP CABLE 84201  
DOCKING STATION 75105**

# Control Kit Installation Drawing - PN 96175

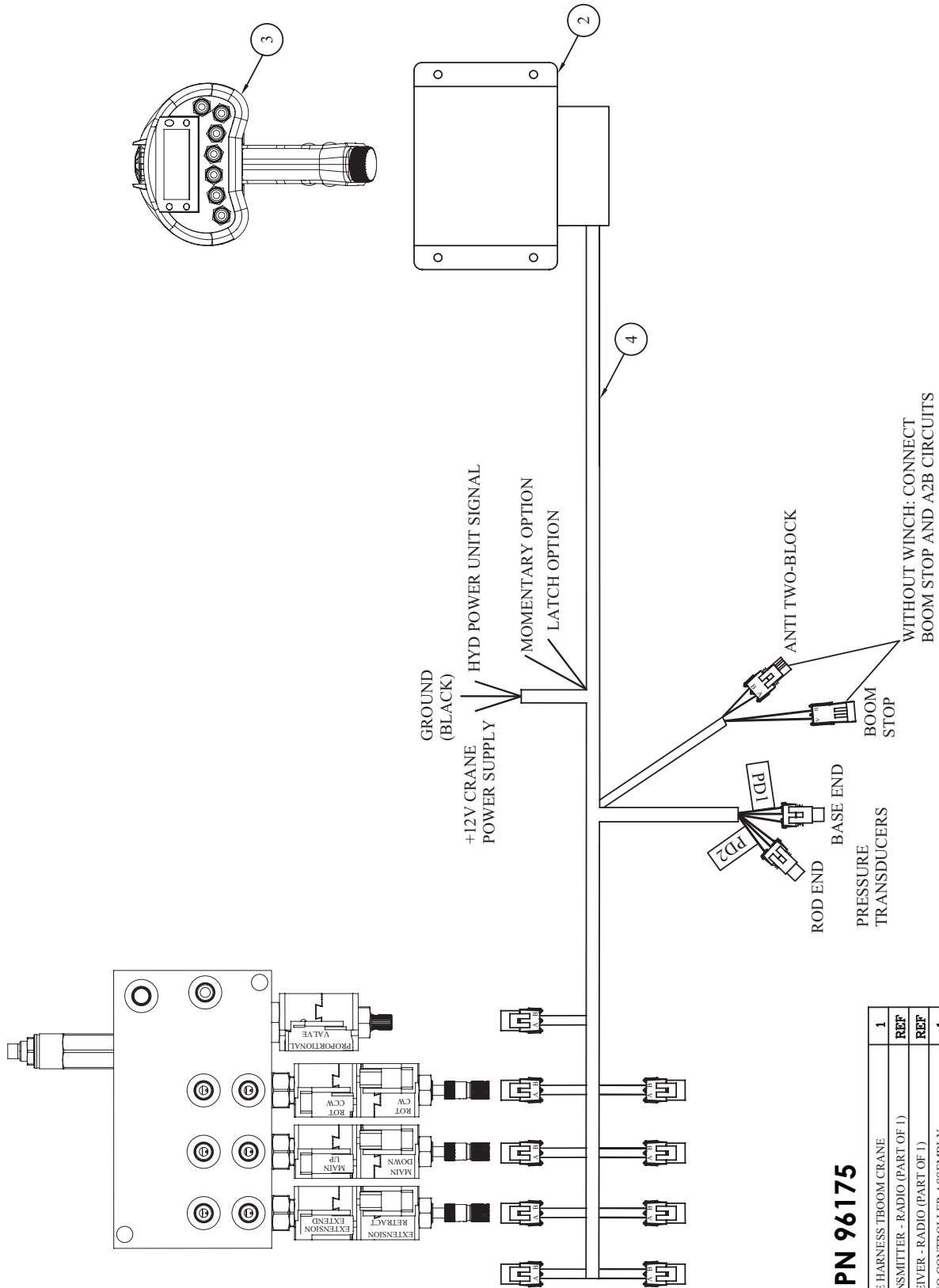

## PN 96175

ITEM	PART No.	DESCRIPTION	QTY
04	76678	WIRE HARNESS TBOOM CRANE	1
03	.	TRANSMITTER - RADIO (PART OF 1)	REF
02	.	RECEIVER - RADIO (PART OF 1)	REF
01	96172	RADIO CONTROLLER ASSEMBLY	1

# Control Kit with Winch Installation Drawing - PN 96175

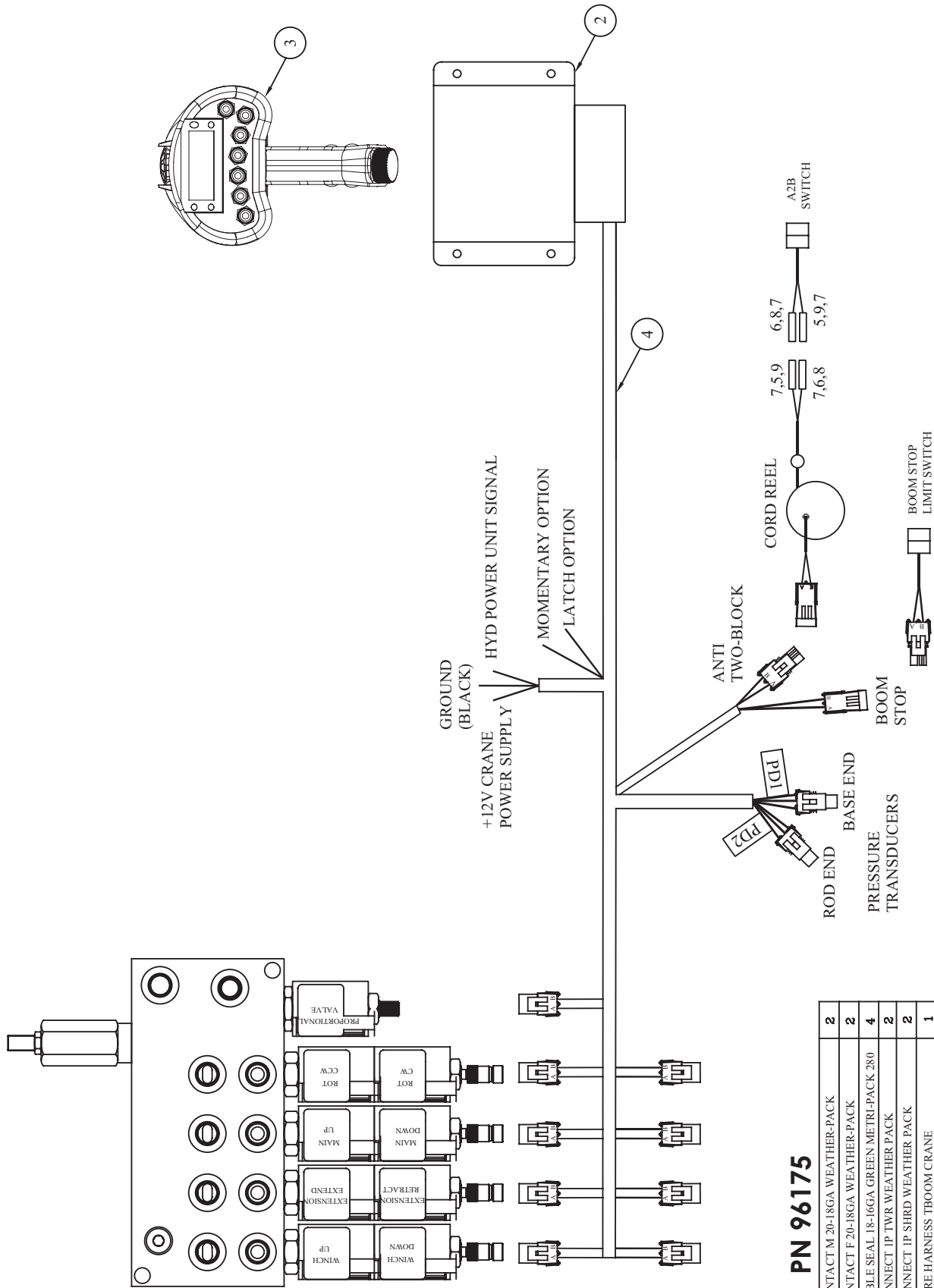

## PN 96175

ITEM	PART No.	DESCRIPTION	QTY
09	9756	CONTACT M 20-18GA WEATHER-PACK	2
08	8383	CONTACT F 20-18GA WEATHER-PACK	2
07	8384	CABLE SEAL 18-16GA GREEN METRI-PACK 280	4
06	12174	CONNECT IP TWR WEATHER PACK	2
05	12173	CONNECT IP SHRD WEATHER PACK	2
04	76678	WIRE HARNESS TBOOM CRANE	1
03	.	TRANSMITTER - RADIO (PART OF 1)	REF
02	.	RECEIVER - RADIO (PART OF 1)	REF
01	96172	RADIO CONTROLLER ASSEMBLY	1

# TC Series Wiring Diagram

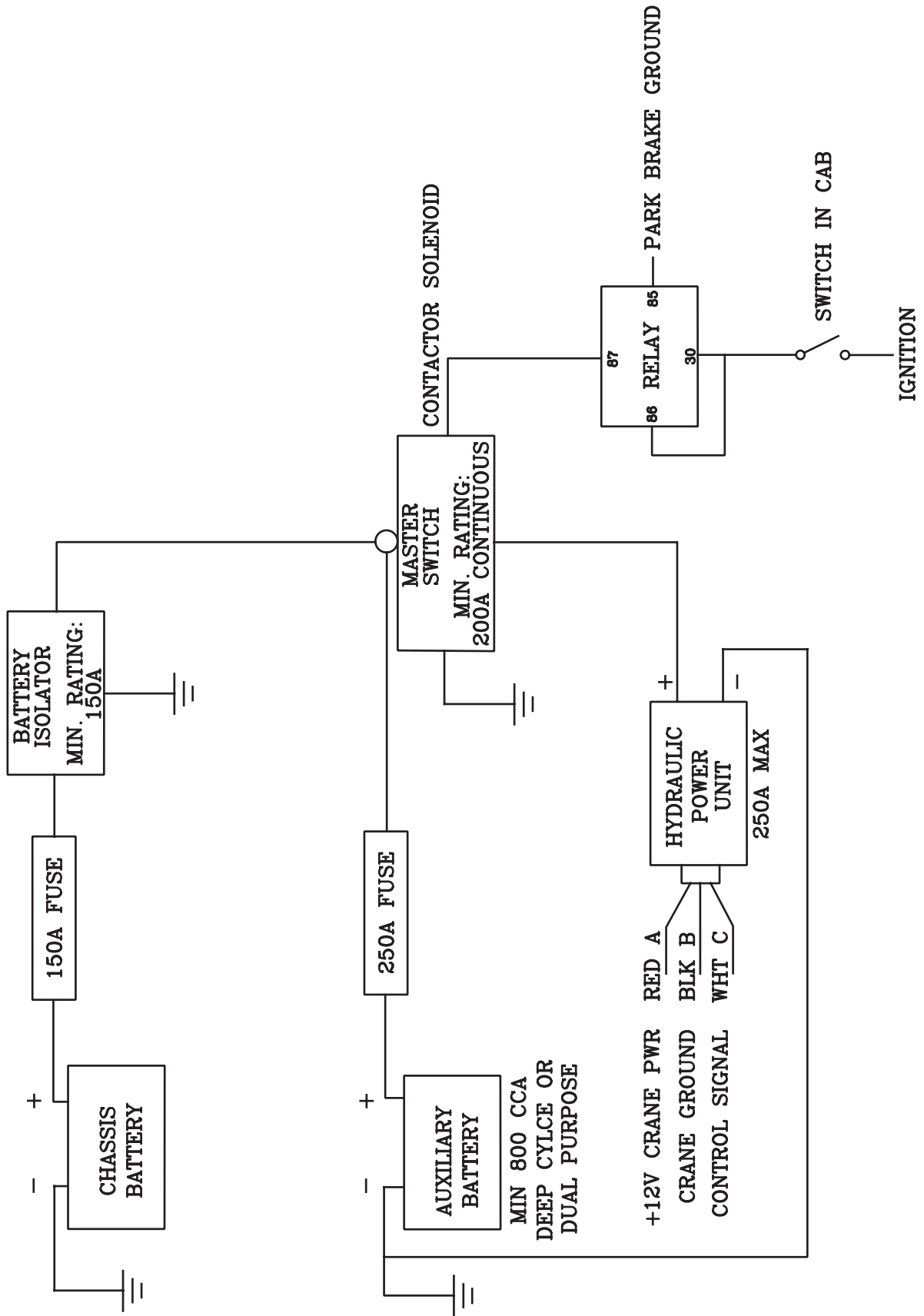



# Hydraulic Kit - PN 96494

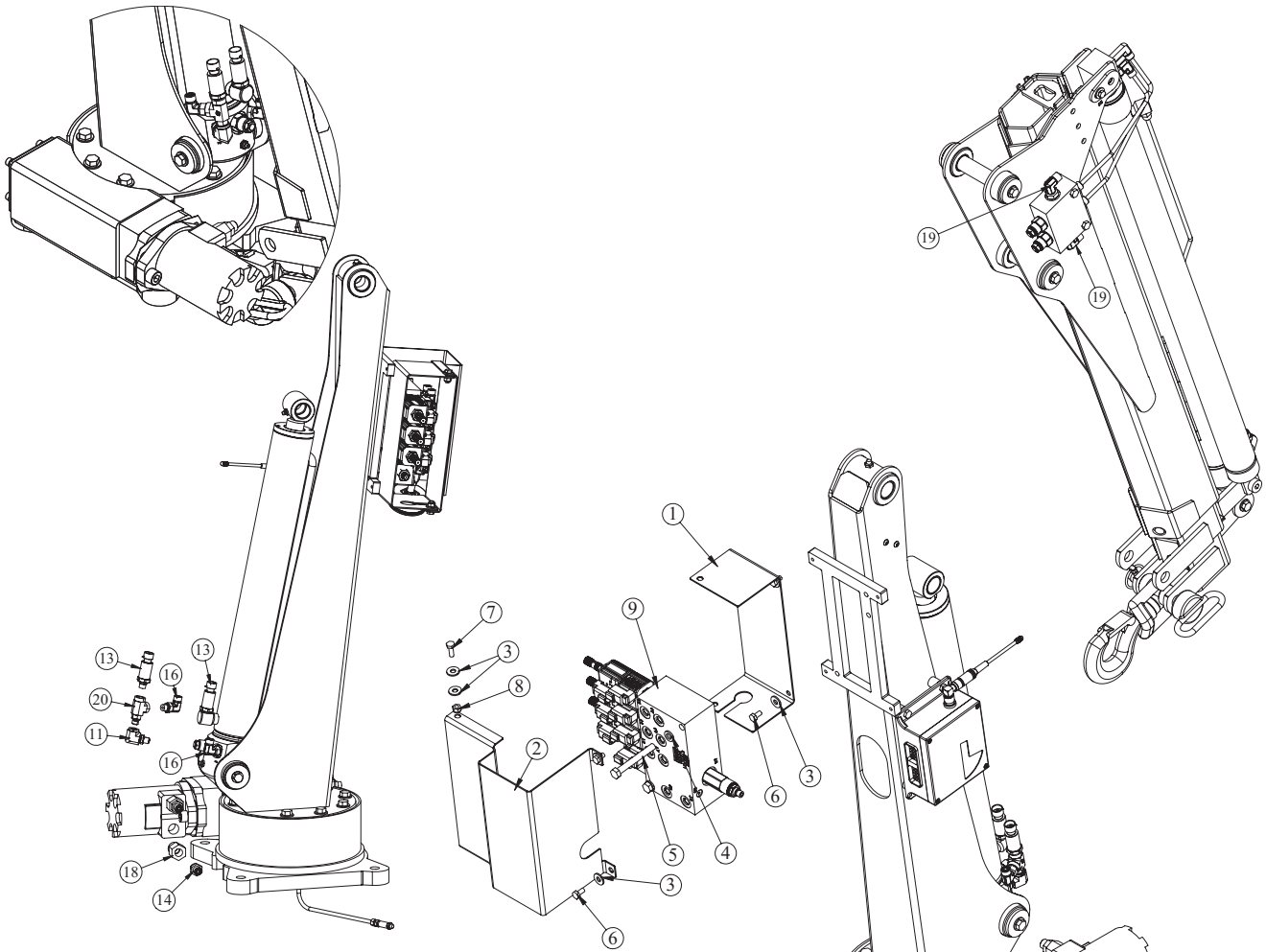

## PN 96494

ITEM	PART	DESCRIPTION	QTY.
1	73946	COVER BACK TC CRANES	1
2	73947	COVER FRONT TC CRANES	1
3	0340	WASHER 0.25 USS FLAT	8
4	0523	WASHER 0.38 LOCK	2
5	C0949	CAP SCR 0.38-16X3.00 HHGR5	2
6	0478	CAP SCR 0.25-20X0.50 HHGR5	4
7	0479	CAP SCR 0.25-20X0.75 HHGR5	2
8	0333	NUT 0.25-20 HHGR5 NYLOC	2
9	73943	VB 3 SECT W/PROP STER4GPM-8 VALVE DEUTSCH	1
10	D0511	FTG 4 MORB PLUG HOLLOW HEX	1
11	51817	FTG 4-4 MAORB-FORB 90	2
12	39780	GAUGE OIL LF 2.5 0-6000 CBM SAE	1
13	28485	TRANSDUCER PRESSURE 5000 PSI	2
14	C4922	FTG 4-6 MFS-MORB STRAIGHT	3
15	0279	FTG 6-6 MFS-MORB STRAIGHT	1
16	C1198	FTG 4-4 MFS-MAORB 90	4
17	D1291	FTG 4-4 MFS-MORB STRAIGHT	4
18	C1111	FTG 10-6 MORB-FORB STRAIGHT REDUCER	2
19	3338	FTG 4-6 MFS-MAORB 90	2
20	96171	FTG 4-4-4 MAORB-FORB-FORB TEE	1

### PART NUMBERS NOT SHOWN:

- 90462 - HOSE KIT TC13
- 4043 - HOSE PROTECTOR 0.50 AS-B-17 WIDTH 2.25 X 20FT
- 32302 - FTG 4-4 MFS-MFS SWIVEL STRAIGHT X 1
- 12171 - FTG 6-6 MFS-MFS SWIVEL STRAIGHT X 1
- 0882 - FTG 6 FFS CAP X 1
- C2032 - FTG 4 FFS CAP X 1

REFER TO INST DWG 90469

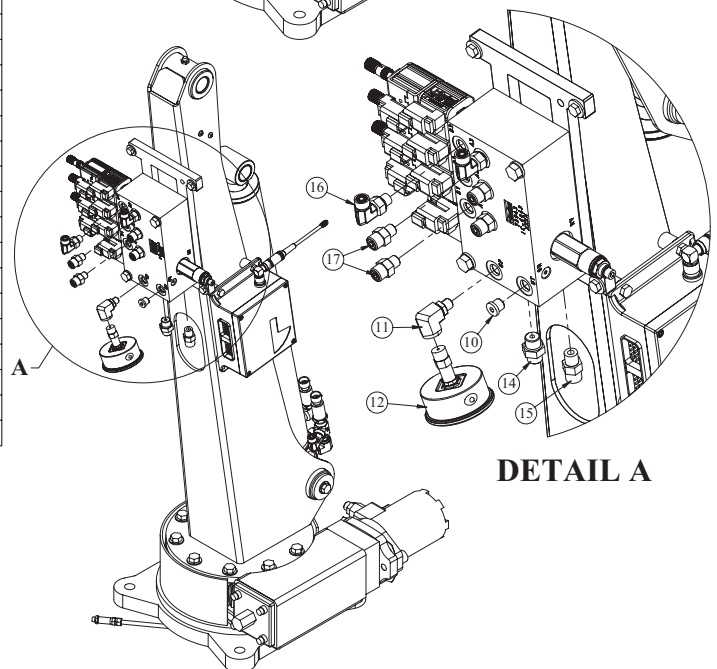

DETAIL A

# Hydraulic Kit w/ Winch - PN 96495

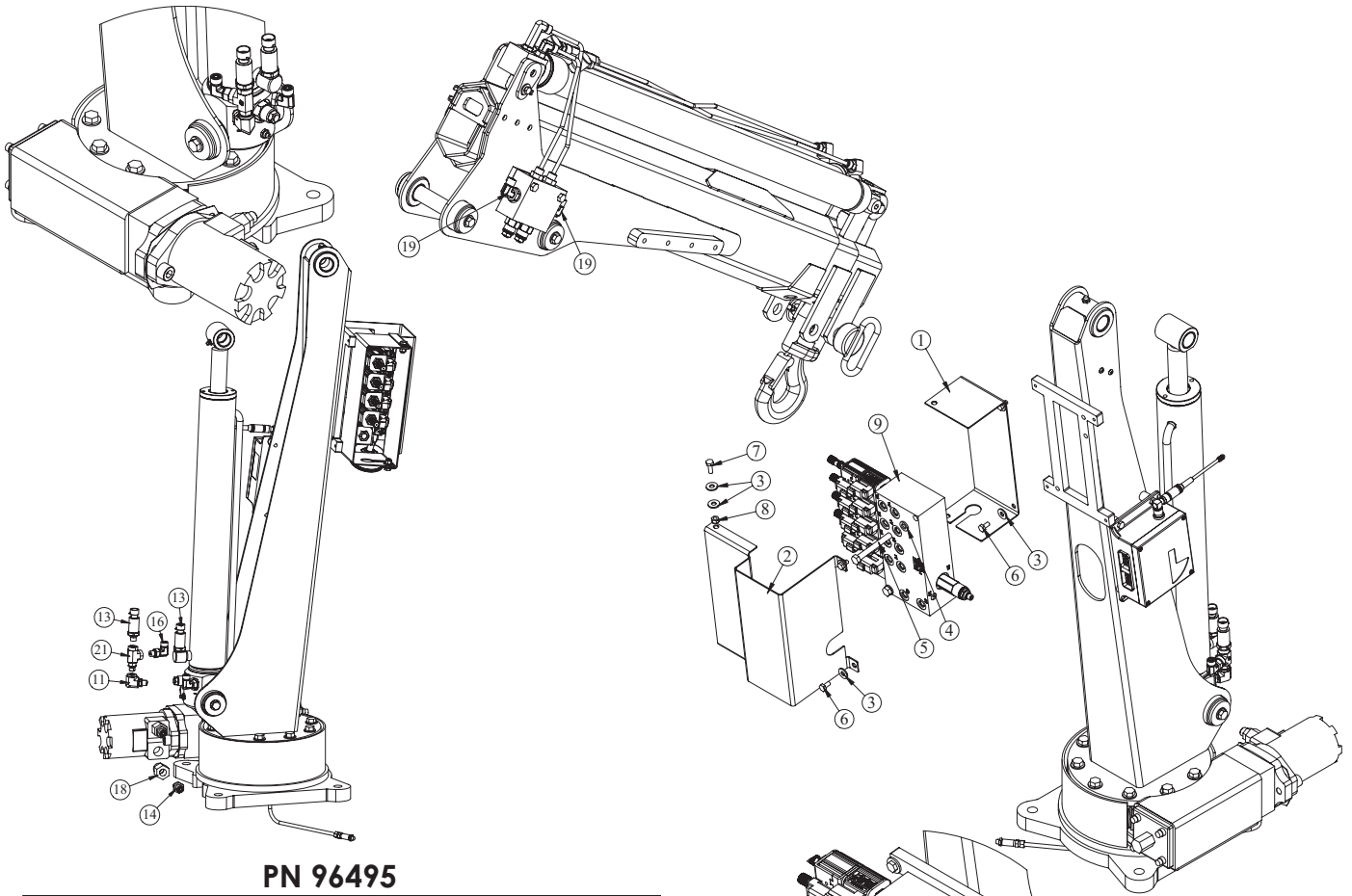

## PN 96495

ITEM	PART	DESCRIPTION	QTY.
1	73946	COVER BACK TC CRANES	1
2	73947	COVER FRONT TC CRANES	1
3	0340	WASHER 0.25 USS FLAT	8
4	0523	WASHER 0.38 LOCK	2
5	C0949	CAP SCR 0.38-16X3.00 HHGR5	2
6	0478	CAP SCR 0.25-20X0.50 HHGR5	4
7	0479	CAP SCR 0.25-20X0.75 HHGR5	2
8	0333	NUT 0.25-20 HHGR5 NYLOC	2
9	72666	VB 4 SECT W/PROP STER4GPM-8 VALVE DEUTSCH	1
10	D0511	FTG 4 MORB PLUG HOLLOW HEX	1
11	51817	FTG 4-4 MAORB-FORB 90	2
12	39780	GAUGE OIL LF 2.5 0-6000 CBM SAE	1
13	28485	TRANSDUCER PRESSURE 5000 PSI	2
14	C4922	FTG 4-6 MFS-MORB STRAIGHT	3
15	0279	FTG 6-6 MFS-MORB STRAIGHT	1
16	C1198	FTG 4-4 MFS-MAORB 90	4
17	D1291	FTG 4-4 MFS-MORB STRAIGHT	6
18	C1111	FTG 10-6 MORB-FORB STRAIGHT REDUCER	2
19	3338	FTG 4-6 MFS-MAORB 90	2
20	D1314	FTG 4-4 MFS-FFSS 90	2
21	96171	FTG 4-4-4 MAORB-FORB-FORB TEE	1

### PART NUMBERS NOT SHOWN:

90462 - HOSE KIT TC13

4043 - HOSE PROTECTOR 0.50 AS-B-17 WIDTH 2.25 X 30FT

32302 - FTG 4-4 MFS-MFS SWIVEL STRAIGHT X 1

12171 - FTG 6-6 MFS-MFS SWIVEL STRAIGHT X 1

0882 - FTG 6 FFS CAP X 1

C2032 - FTG 4 FFS CAP X 1

C4922 - FTG 4-6 MFS-MORB STRAIGHT X 2

REFER TO INST DWG 94137

### MAKE WINCH HOSES:

85358 - HOSE 0.25(3000PSI)-4FFSS SHORT-4FFSS 90 SHORT-50CL

94136 - HOSE 0.25(3000PSI)-4FFSS SHORT-4FFSS 90 LONG-50CL

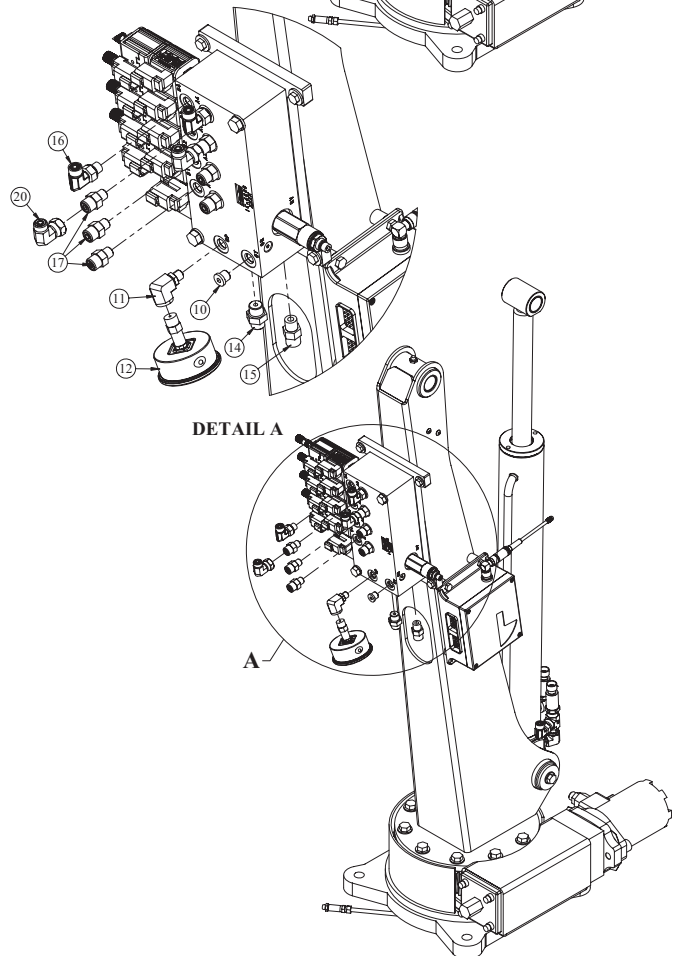

# TC13 Hydraulic Schematic

TC13 Standard

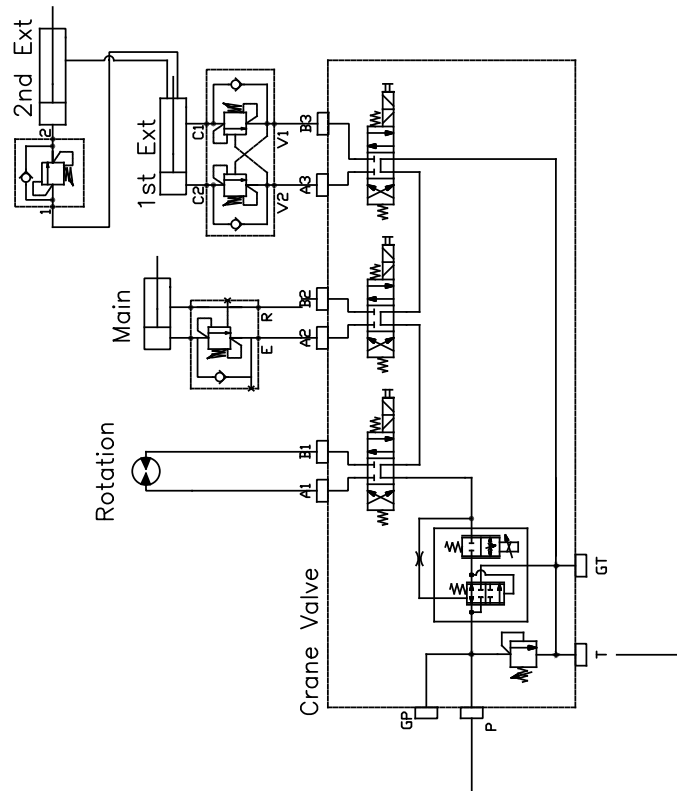

TC13 with Winch

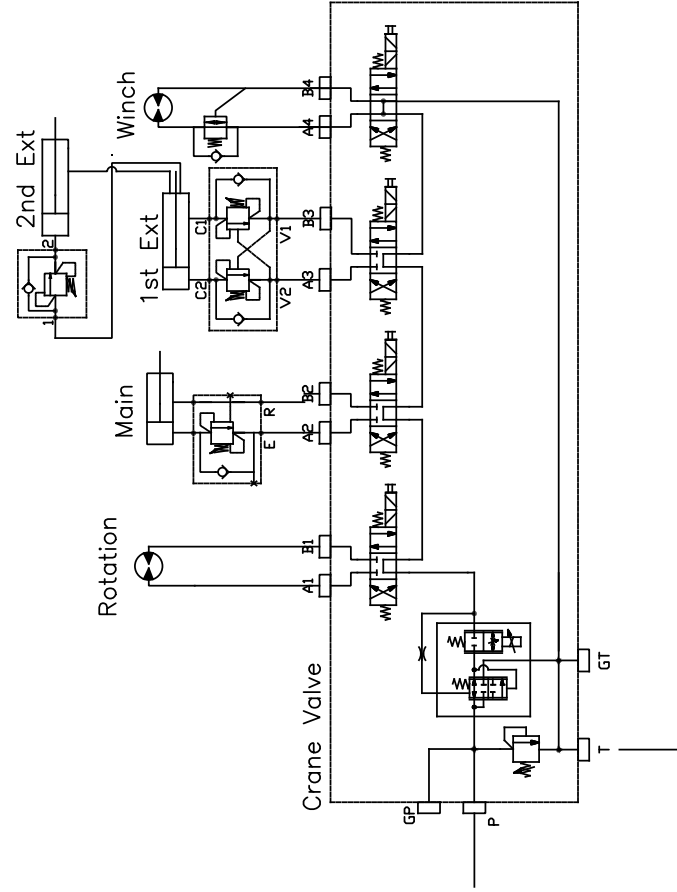

# Hydraulic Kit Installation Drawing - PN 90469

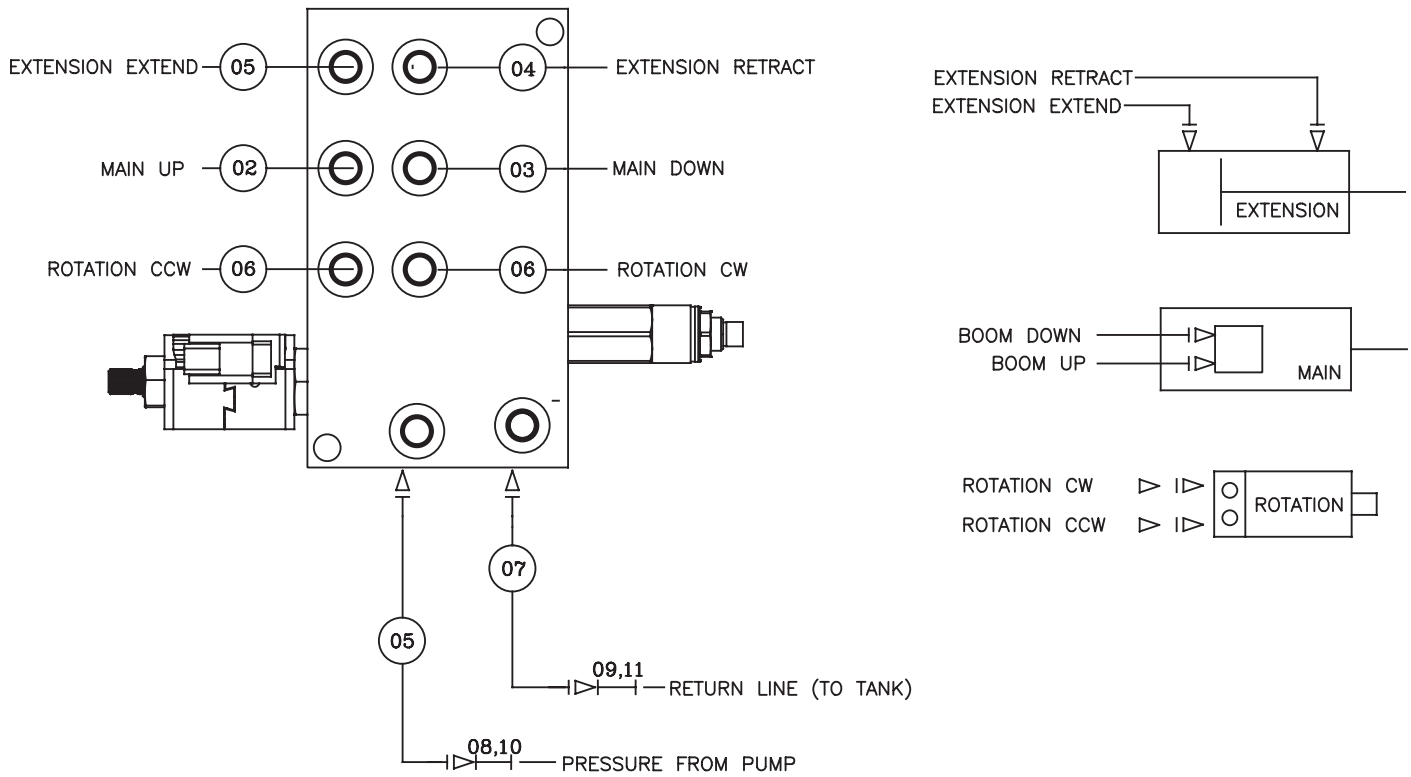

## PN 90469

12	4043	HOSE PROTECTOR 0.50 AS-B-17	20'
11	0882	FTG 6 FFS CAP	1
10	C2032	FTG 4 FFS CAP	1
09	12171	FTG 6-6 MFS-MFS SWIVEL STRAIGHT	1
08	32302	FTG 4-4 MFS-MFS SWIVEL STRAIGHT	1
07	90468	HOSE-HYD .38 X 34	1ref
06	90467	HOSE-HYD .25 X 54	2ref
05	90466	HOSE-HYD .25 X 34	2ref
04	90465	HOSE-HYD .25 X 28	1ref
03	90464	HOSE-HYD .25 X 40	1ref
02	90463	HOSE-HYD .25 X 38	1ref
01	90462	HOSE KIT TC13 (incl:2-7)	1
ITEM	PART No.	DESCRIPTION	QTY

NOTE: USE HOSE PROTECTOR  
P/N 4043 OVER ALL HOSES

# Hyd. Kit w/ Winch Installation Drawing - PN 94137

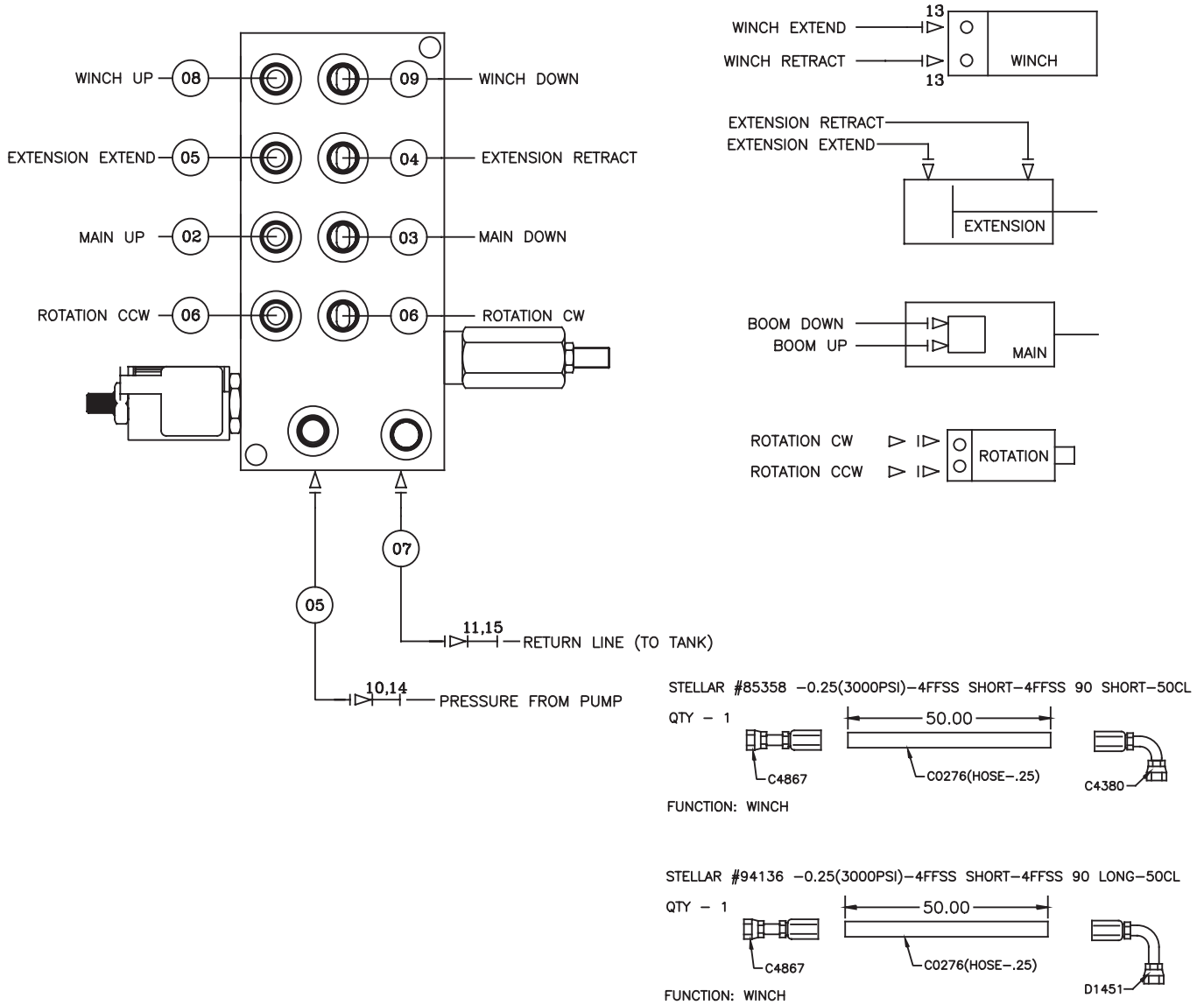

## PN 94137

15	0882	FTG 6 FFS CAP	1
14	C2032	FTG 4 FFS CAP	1
13	C4922	FTG 4-6 MFS-MORB STRAIGHT	2
12	4043	HOSE PROTECTOR 0.50 AS-B-17	30'
11	12171	FTG 6-6 MFS-MFS SWIVEL STRAIGHT	1
10	32302	FTG 4-4 MFS-MFS SWIVEL STRAIGHT	1
09	94136	HOSE-HYD .25 X 50	1
08	85358	HOSE-HYD .25 X 50	1
07	90438	HOSE-HYD .38 X 34	1ref
06	90467	HOSE-HYD .25 X 54	2ref
05	90466	HOSE-HYD .25 X 34	2ref
04	90465	HOSE-HYD .25 X 28	1ref
03	90464	HOSE-HYD .25 X 40	1ref
02	90463	HOSE-HYD .25 X 38	1ref
01	90462	HOSE KIT TC13 (incl:2-7)	1
ITEM	PART No.	DESCRIPTION	QTY

NOTE: USE HOSE PROTECTOR  
P/N 4043 OVER ALL HOSES

# Optional Power Unit Assembly - PN 77897

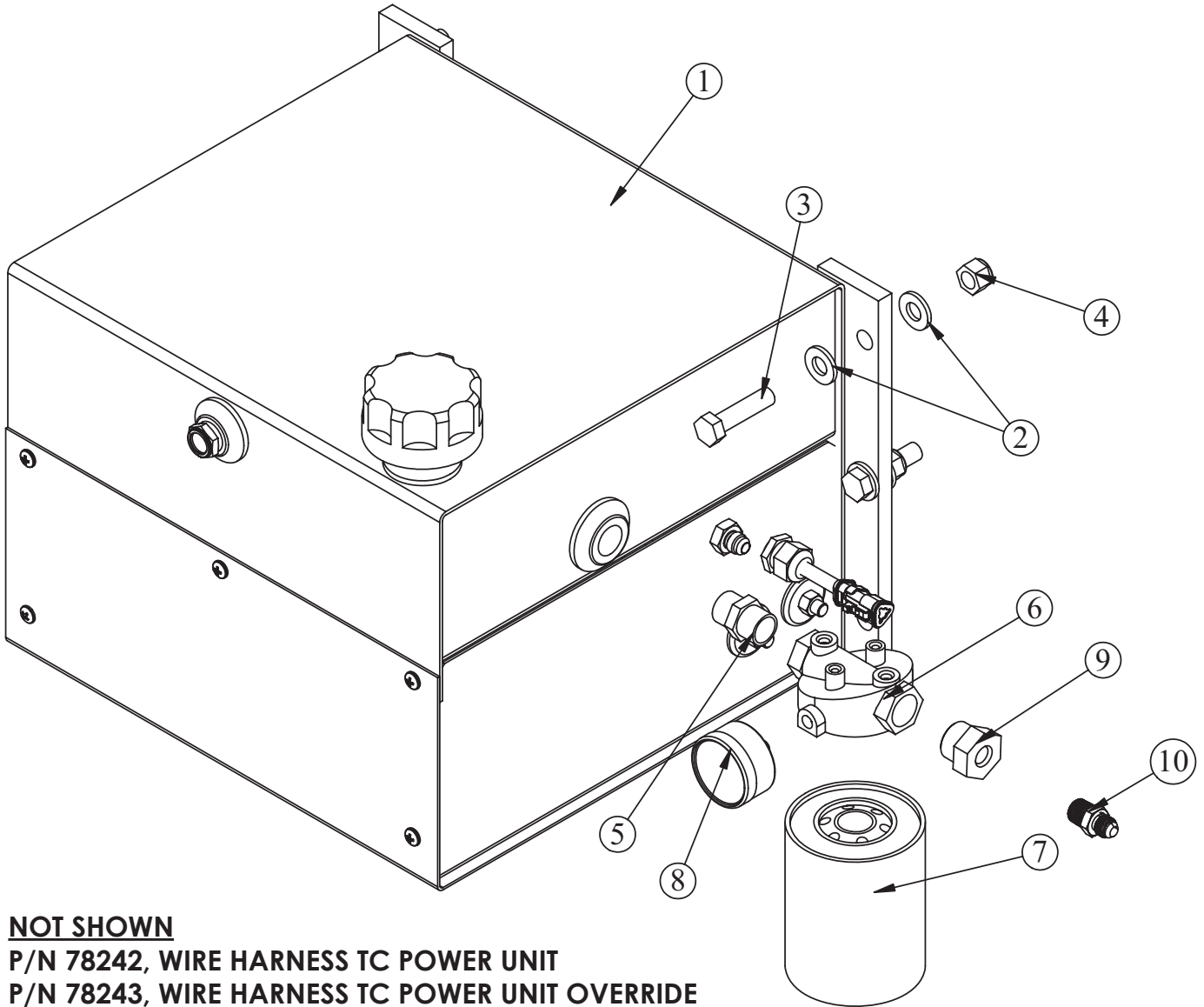

**NOT SHOWN**  
P/N 78242, WIRE HARNESS TC POWER UNIT  
P/N 78243, WIRE HARNESS TC POWER UNIT OVERRIDE

## PN 77897

ITEM	PART	DESCRIPTION	QTY.
1	77896	POWER UNIT 12V 2.5GPM 4 GAL RSRVR	1
2	D0790	WASHER 0.50 SAE FLAT YELLOW GR8	8
3	8833	CAP SCR 0.50-13X2.00 HHGR8	4
4	5468	NUT 0.50-13 HHGR8 NYLOC	4
5	C6162	FTG 12-12 MP-MP HEX NIPPLE STRAIGHT	1
6	C6226	FILTER HEAD	1
7	C6227	FILTER SHORT	1
8	16145	GAUGE PRES FILTER SERVICE CI20	1
9	53485	FTG 12-6 MP-FP REDUCER BUSHING	1
10	77898	FTG 6-6 MJ-MP STRAIGHT	1

**NOTE: ALL PARTS TO BE SHIPPED LOOSE**

## Face Seal/O-Ring Size Chart

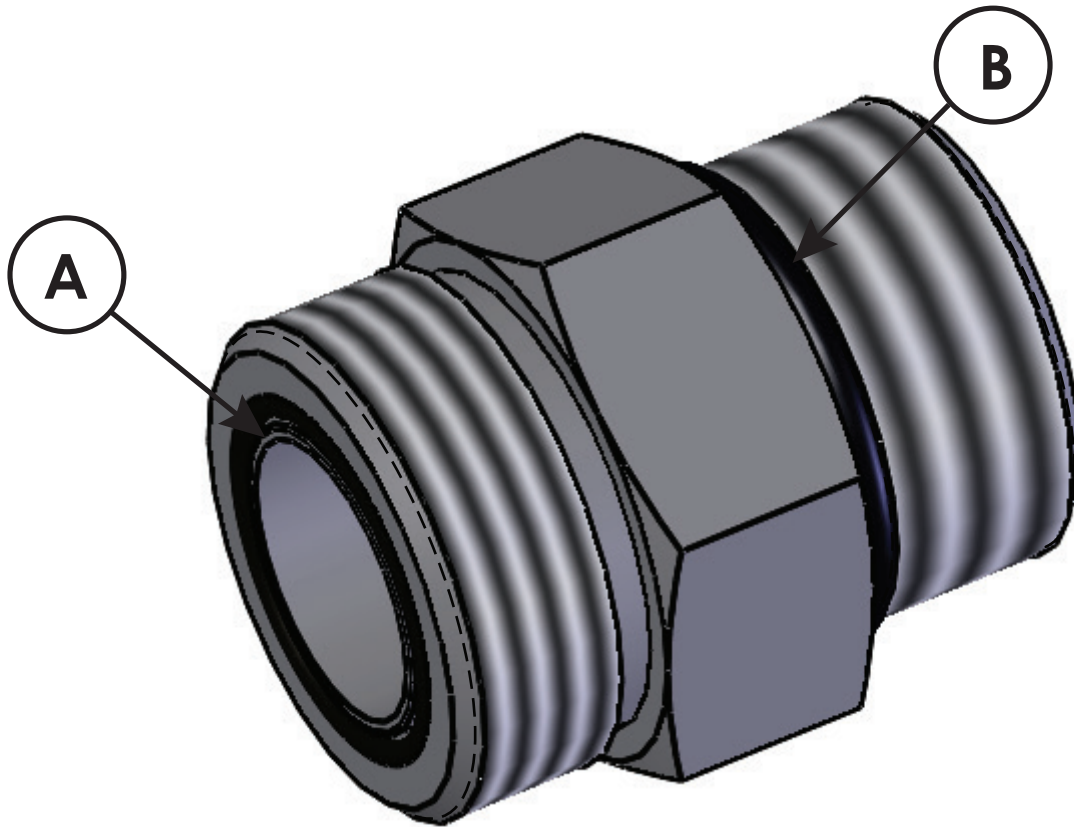

Hose Size	Fitting Size	Face Seal (A) Stellar® PN	O-ring Boss (B) Stellar® PN
1/4"	#4	C2027	D1245
3/8"	#6	C2028	D1246
1/2"	#8	C2029	D1247
5/8"	#10	32223	D1248
3/4"	#12	D1244	D1249
1"	#16		D1250

# Stability Procedure

## Definition of Stability for the Stellar® Telescopic Crane Products:

A truck is stable until the load cannot be lifted off the ground with the winch, without tipping over the truck. Every Stellar® Crane installed must be tested for stability to determine the actual load capacity of the final truck package. The actual test data must be recorded and supplied with the truck at the time of in-service and should be kept with the truck at all times. The following procedure will test the truck package for stability and will provide a stability capacity chart. The load limit information shown on the stability capacity chart is formulated on 85% tipping.

## Set Up:

1. Locate the truck on a test course in position for loading and engage travel brakes.
2. Set stabilizers so that they make contact with firm, level footing.
3. Operate the crane under partial load to assure operator proficiency and proper machine function.
4. Put the radio into Stability Test Mode:
  - A. Push the bottom four switches up and hold until all lights come on (approximately 5 seconds.)



- B. At this point, the crane will have enough capacity to handle the weight for the stability test.
- C. The radio will timeout of stability mode after 30 minutes or when the E-Stop button is pushed.

*Note: The radio can only be put into stability mode five times. After that, the radio would have to be returned to Stellar to be reprogrammed to allow additional stability testing. All other radio functions will work properly even if stability mode is not available.*



# Stability Procedure Continued...

TC13 Stability Data		
Model	Max Horiz. Reach	Test Weight
TC13	8.86 ft	1,145 lbs

## Test Procedure

1. Rotate the crane into Zone 1 position.
2. With the crane fully retracted and the boom horizontal, winch the test weight off the ground. Note: Keep weight within six inches of the ground at all times.
3. Extend the boom outward until full extension has been reached or until the truck becomes unstable (Again, use the winch to keep the weight within six inches of the ground.)
4. If the boom goes full extension without becoming unstable, the crane is termed stable for this zone and 100% can be written in the Zone 1 data box.
5. If the truck becomes unstable prior to going full extension, retract the boom until the truck becomes stable and measure the horizontal reach in this position (center of rotation to boom tip). This is the stable horizontal reach for this zone. Stable horizontal reach divided by Maximum horizontal reach multiplied by 100 equals the percentage of rated capacity for this zone. Use the following formula to determine the percentage of rated capacity:

$$\frac{\text{Stable Horizontal Reach}}{\text{Max Horizontal Reach}} \times 100 = \text{Percentage of Rated Capacity}$$

6. Record this number in the data box for Zone 1. This is the revised capacity due to stability for this zone.
7. Repeat this procedure for each zone until the worksheet is completed.
8. This is the revised capacity based on stability of this package.

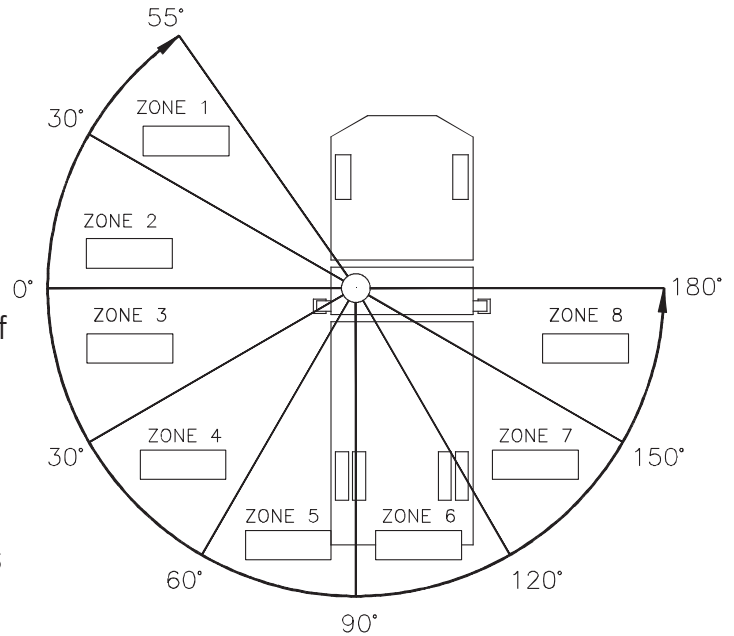

## Crane Load Level Indicator

Stellar® Cranes are shipped with a load level indicator that is used to determine if the truck is level (side to side) before using the crane to pick/move a load. This level should be installed in the isolated crane compartment of the body. If level indicator is missing or damaged, please contact Stellar Customer Support for a replacement.



PN 76483

# Decal Placement - PN 76875

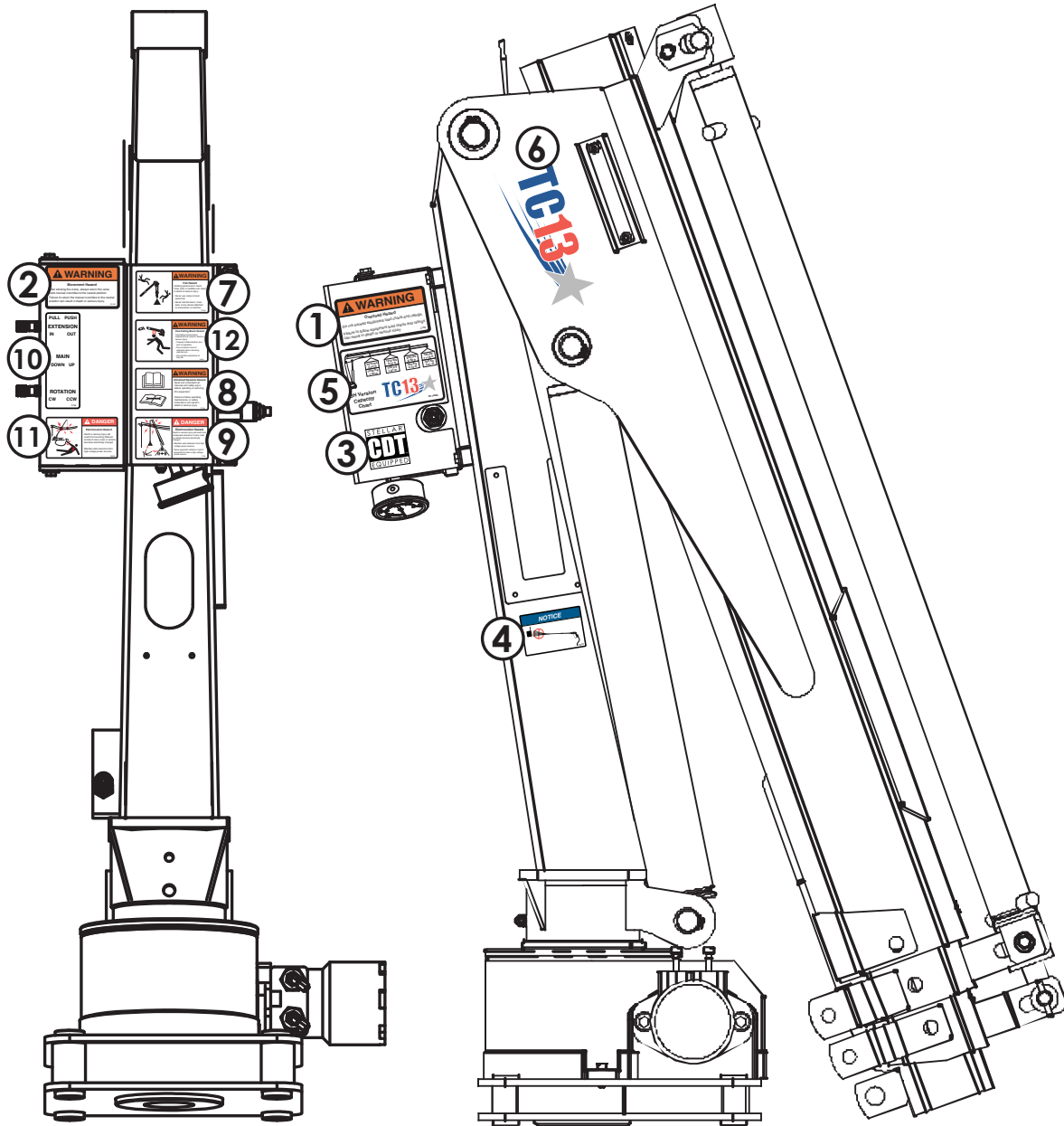

**PN 76875**  
Rev B - 03/08/16

For use with Crane Package

ITEM	PN	DESCRIPTION	LOCATION	QTY
01	4189	DECAL WARNING OVERLOAD	On mast valve bank cover - side	1
02	25159	DECAL WARNING MANUAL OVERRIDES	On mast next to valve bank controls	1
03	54588	DECAL CDT 2.00 x 2.00	On mast valve bank cover - side	1
04	73929	DECAL PRESSURE WASH	On mast under receiver box	1
05	76879	DECAL CAPACITY TC13 2H	On mast valve bank cover - side	1
06	77086	DECAL IDENTIFICATION TC13	Crane boom - both sides	2
07	77733	DECAL WARNING HOISTING PERSONNEL	On mast valve bank cover - back	1
08	77734	DECAL WARNING UNTRAINED OPERATOR	On mast valve bank cover - back	1
09	77735	DECAL DANGER ELECTROCUTION SMALL	On mast valve bank cover - back	1
10	77736	DECAL VB 3 SECTION TC	On mast next to valve bank controls	1
11	78078	DECAL DANGER ELECTROCUTION REMOTE 2.00 X 3.50	On mast next to valve bank controls	1
12	78079	DECAL WARNING MANUAL EXT 2.00 X 3.50	On mast valve bank cover - back	1

# Chapter 3 - Assembly Drawings

## Base Assembly - PN 88695

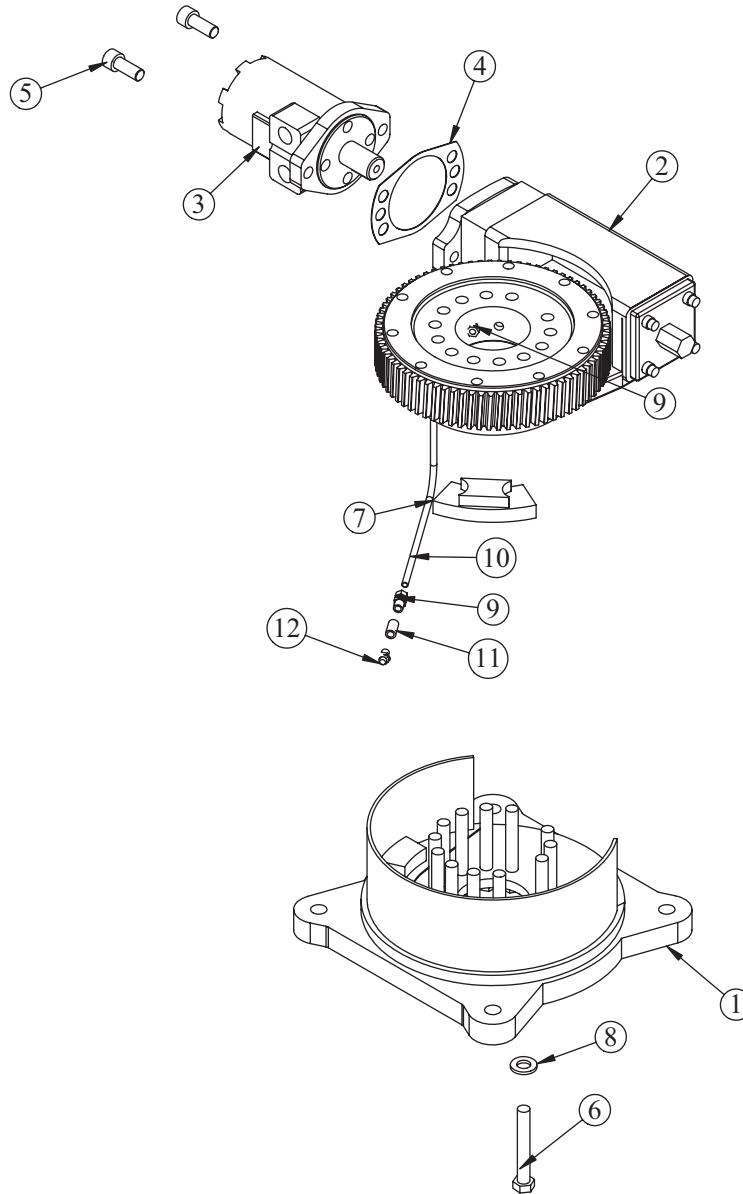

### PN 88695

ITEM	PART	DESCRIPTION	QTY.
1	88882	BASE TC13	1
2	41640	BEARING SWING DRIVE 170-00058-1	1
3	62487	ROTATION MOTOR EC3200	1
4	21151	GASKET MOTOR 008-10056-1	1
5	D1307	CAP SCR 0.50-13X1.25 SHGR8 W/ RED PATCH	2
6	30750	CAP SCR 0.50-13X3.50 HHGR8	13
7	42795	STOP SLIDING EC3200	1
8	D0790	WASHER 0.50 FLAT GR8	13
9	D1345	FTG CPRSN 0.12NPT/0.25 TUBE	2
10	D1810	TBE AIR SAEJ844 TYPE A .25 (RM)	2.5
11	22161	FTG 2-2 FP-FP COUPLER STRAIGHT BRASS	1
12	56589	ZERK 1/8 NPT STRAIGHT LONG THREAD	1

# Gear Bearing Assembly - PN 41640

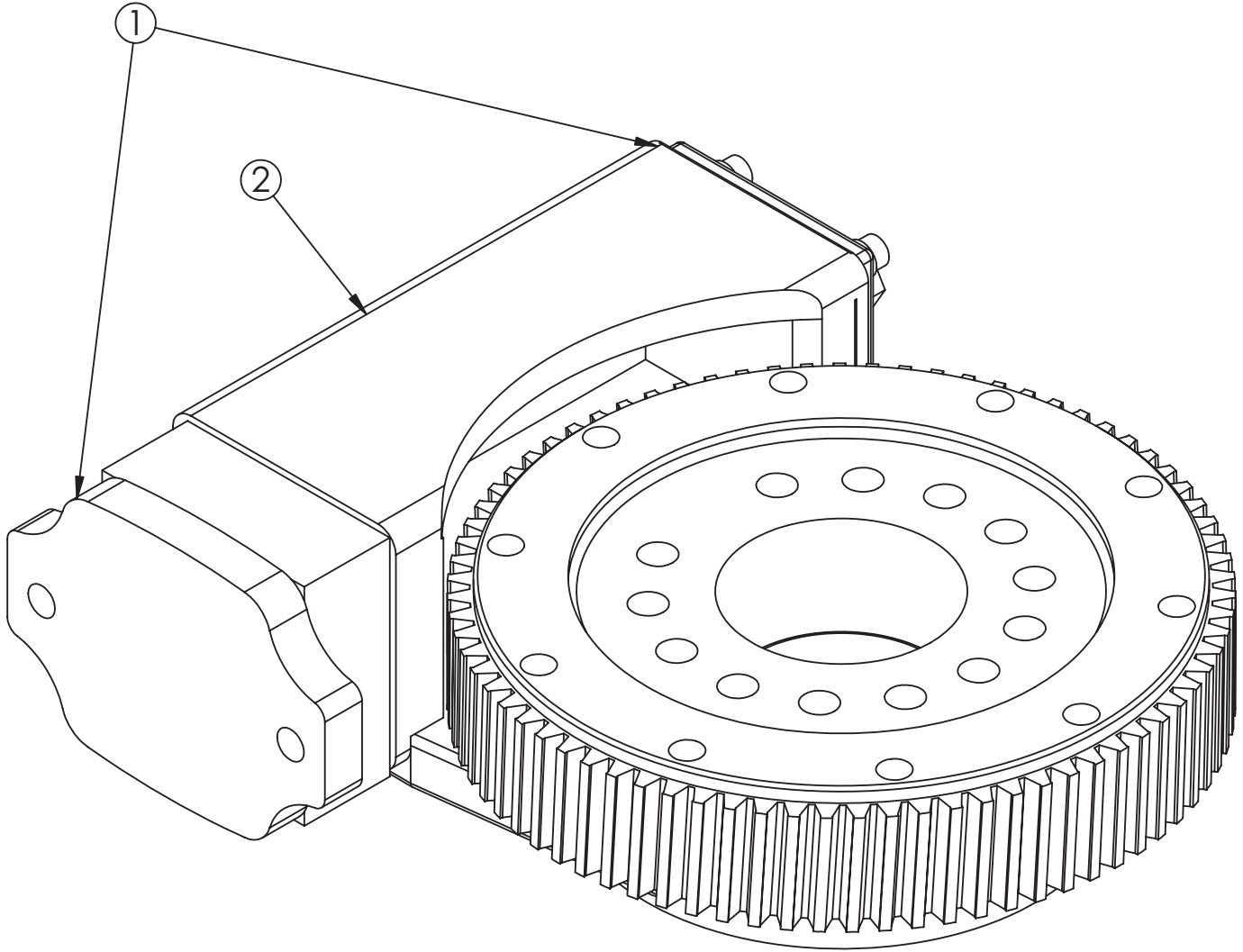

## PN 41640

ITEM	PART	DESCRIPTION	QTY.
1	44383	BEARING AND SEAL KIT EC3200 GP	1
2	44375	WORM EC3200 GEAR PROD 170-10081-1	1

ITEM	PART	DESCRIPTION	QTY.
1	77737	BEARING AND SEAL KIT EC3200 KNMTS	1
2	77738	WORM EC3200 KNMTS	1

# Mast Assembly - PN 88884

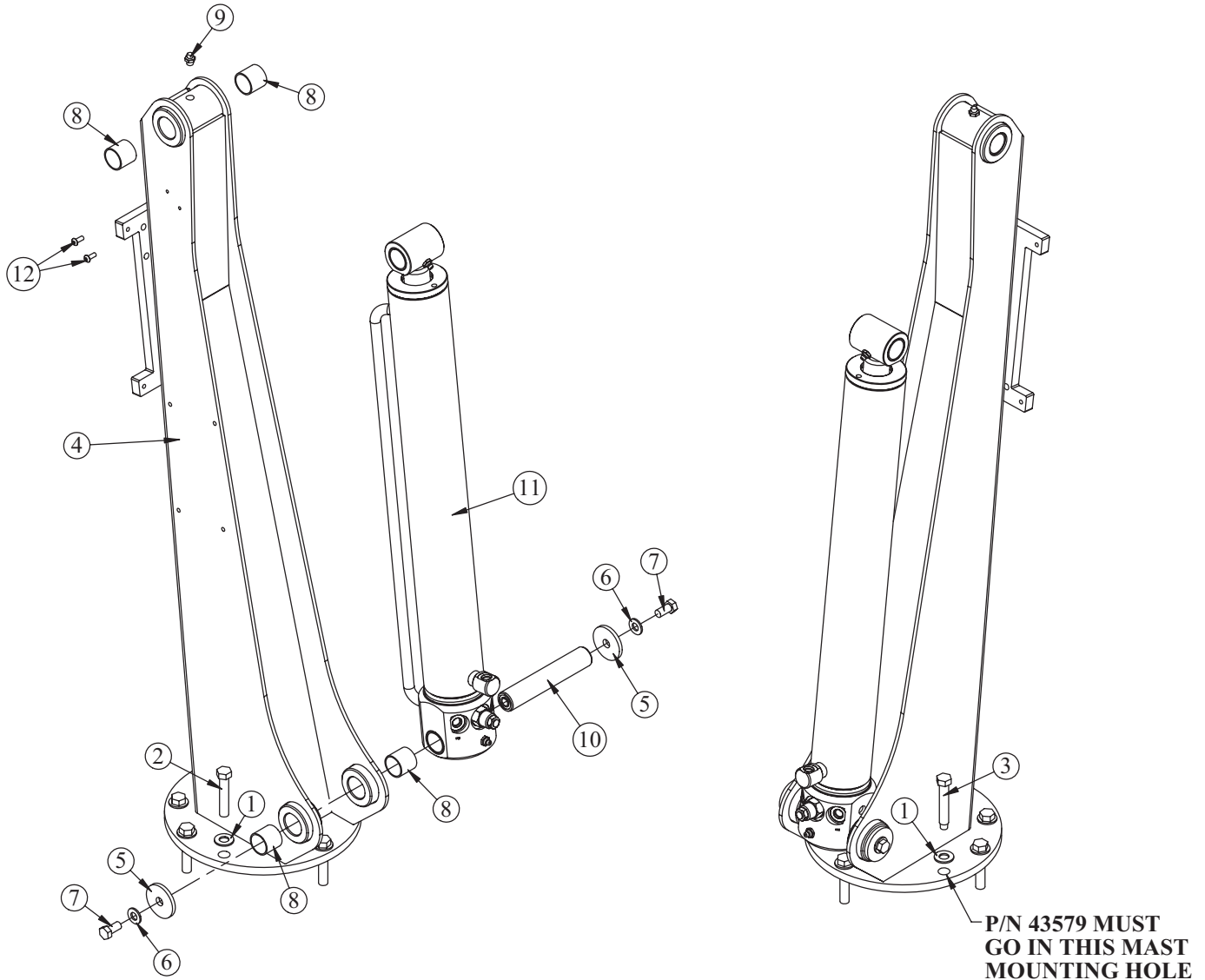

## PN 88884

ITEM	PART	DESCRIPTION	QTY.
1	42788	WASHER 0.44 SAE FLAT YELLOW GR8	8
2	42789	CAP SCR 0.44-14X2.25 HHGR8 ZY	7
3	43579	CAP SCR 0.44-14X2.63 EC3200 STOP	1
4	88885	MAST TC13	1
5	9320	PIN CAP 0.44X1.75X0.19 YZ	2
6	C6353	WASHER 0.38 SAE FLAT YELLOW GR8	2
7	9843	CAP SCR 0.38-16X0.75 HHGR8	2
8	0069	BUSHING BPC16DXR16 1.00X1.00	4
9	c1592	ZERK 1/8 NPT STRAIGHT	1
10	88937CR	PIN 1.00X5.38 D&T ZC	1
11	89038	CYLINDER 2.50X18.13	1
12	D1711	CAP SCR #10-24X0.50 BTNHD SS	2

# Boom Assembly - PN 88944

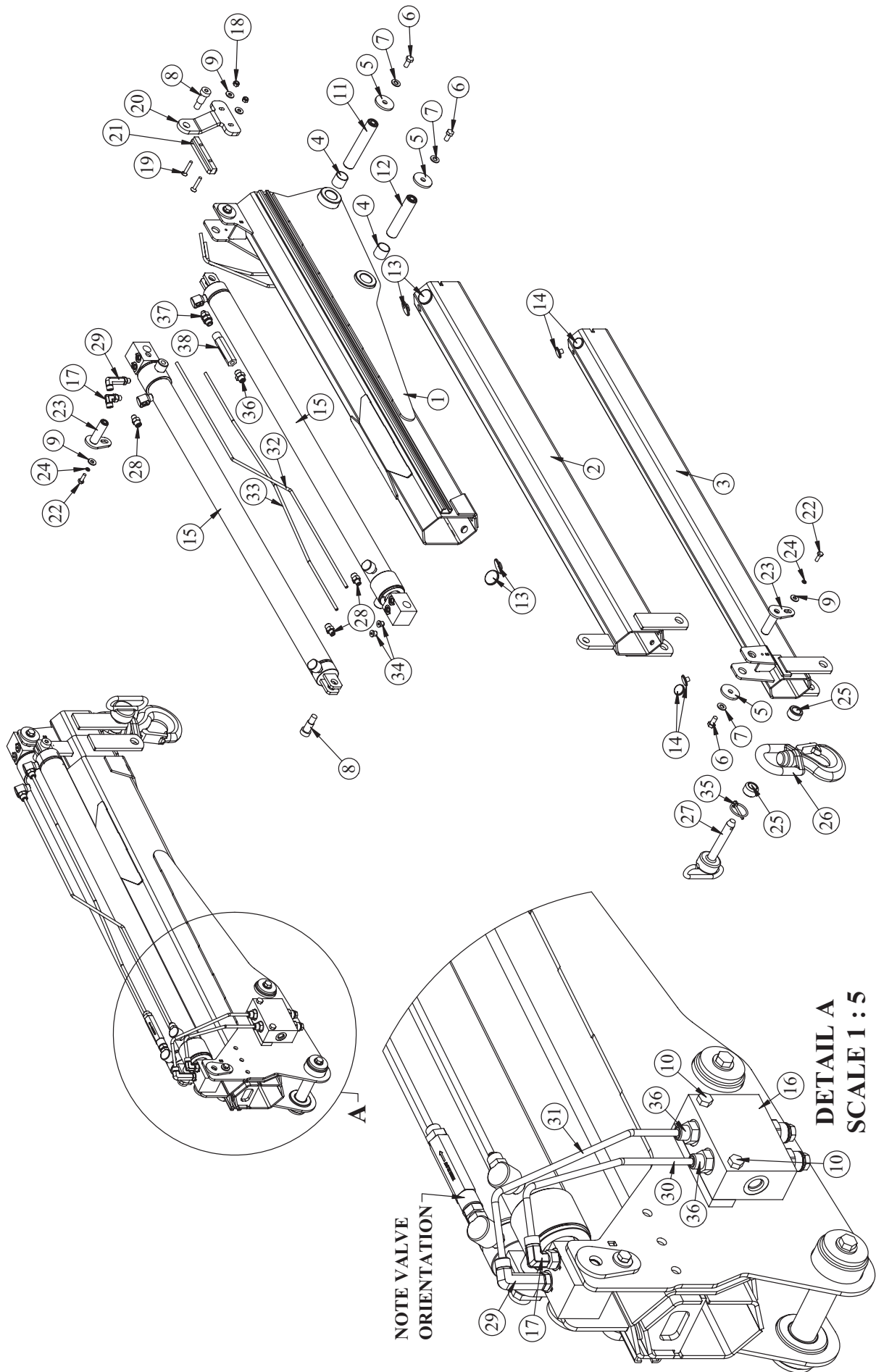

# Boom Bill - PN 88944

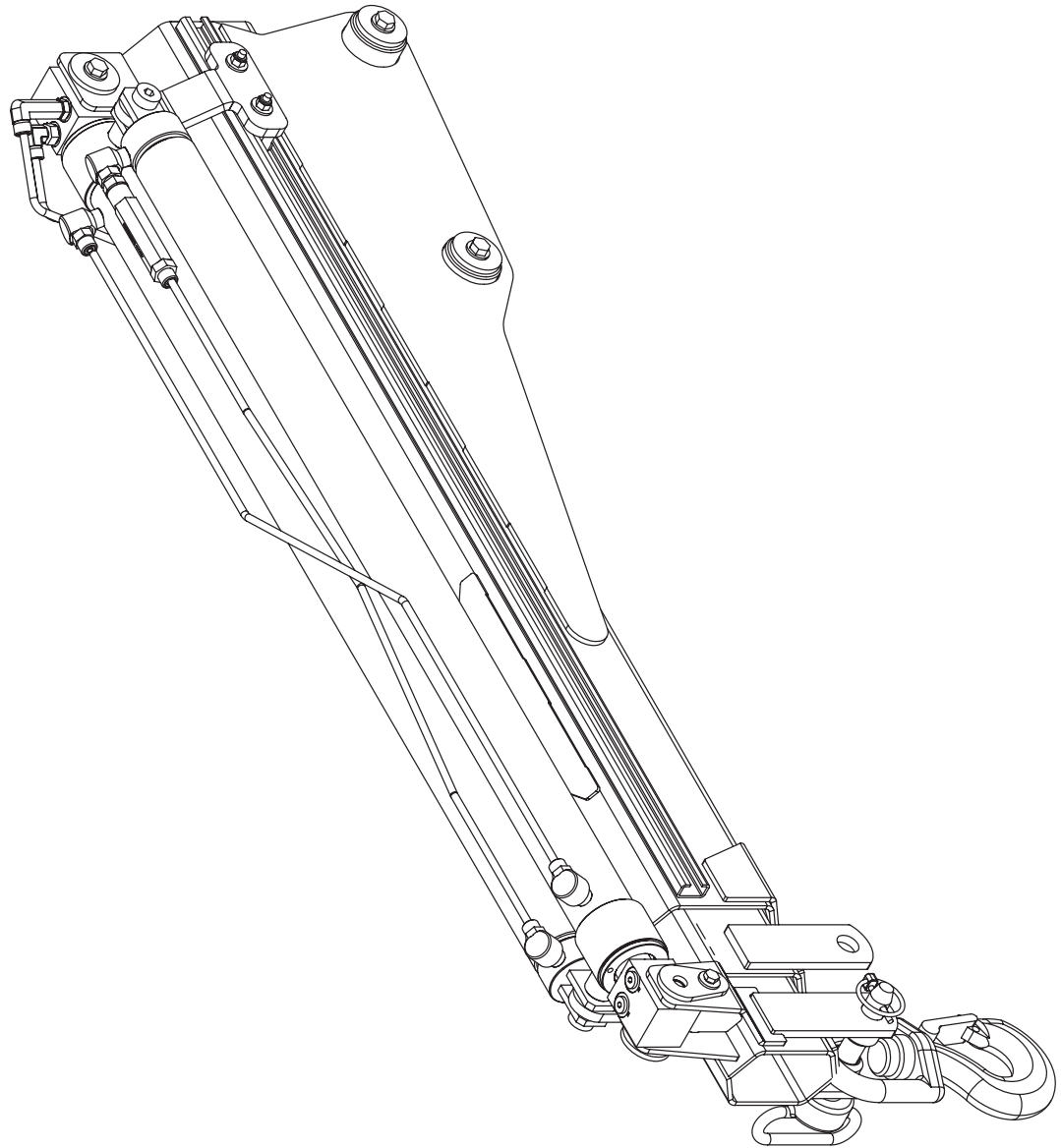

ITEM	PART	DESCRIPTION	QTY.
1	88943	INNER BOOM TC13	1
2	88989	BOOM WLDMT 1ST EXT TC13	1
3	88990	BOOM WLDMT 2ND EXT TC13	1
4	0069	BUSHING BPC16DXR16.1.00X1.00	4
5	9320	PIN CAP 0.44X1.75X0.19 YZ	6
6	9843	CAP SCR 0.38-1.6X0.75 HHGR8	6
7	C6353	WASHER 0.38 SAE FLAT YELLOW GR8	6
8	42155	BOLT SHOULDER 0.63X1.00 0.50-13X0.75	2
9	0340	WASHER 0.25 USS FLAT	4
10	0487	CAP SCR 0.31-1.8X1.75 HHGR5	2
11	88937CR	PIN 1.00X5.38 D&T ZC	1
12	89752CR	PIN 1.00X4.50 D&T ZC	1
13	19457	WEAR PAD 0.16X1.38 RND	4
14	25393	WEAR PAD 0.38X1.00 RND	4
15	88997	CYLINDER 1.50X33.50	2
16	89378	MANIFOLD ASM C'BAL DOUBLE CBBDLJNZ4U	1
17	C1198	FIG 4-4 MFS-MAORB 90	1
18	0333	NUT 0.25-20 HHGR5 NYLOC	2
19	76182	CAP SCR 0.25-20X1.50 FHSB	2
20	90004	PLATE CYLINDER GUIDE TC13	1
21	90120	WEAR PAD GUIDE CYL TC13	1
22	0479	CAP SCR 0.25-20X0.75 HHGR5	2
23	89702CR	PIN TEAR DROP .75X2.44 ZC	2
24	0521	WASHER 0.25 LOCK	2
25	89903	COLLAR 0.78X1.25X0.81	2
26	25842	HOOK 3 TON SWIVEL CROSBY 1028618	1
27	17007	PIN HITCH 0.75X4.00	1
28	D1291	FIG 4-4 MFS-MORB STRAIGHT	3
29	73948	FIG 4-4 MFS-MAORB 90	1
30	90211	TUBE ASM 0.25 TC13 BOOM VALVE RETRACT ZC	1
31	90212	TUBE ASM 0.25 TC13 BOOM VALVE EXTEND ZC	1
32	90213	TUBE ASM 0.25 TC13 BOOM CYL EXTEND ZC	1
33	90214	TUBE ASM 0.25 TC13 BOOM CYL RETRACT ZC	1
34	D0511	FIG 4 MORB PLUG HOLLOW HEX	2
35	5753	PIN 0.19X1.56 LYNCH	1
36	C4922	FIG 4-6 MFS-MORB STRAIGHT	3
37	92067	FIG 6-4 MAORB-MORB STRAIGHT	1
38	92949	VALVE SEQUENCE 5 GPM	1

# Boom w/ Winch Assembly - PN 92671

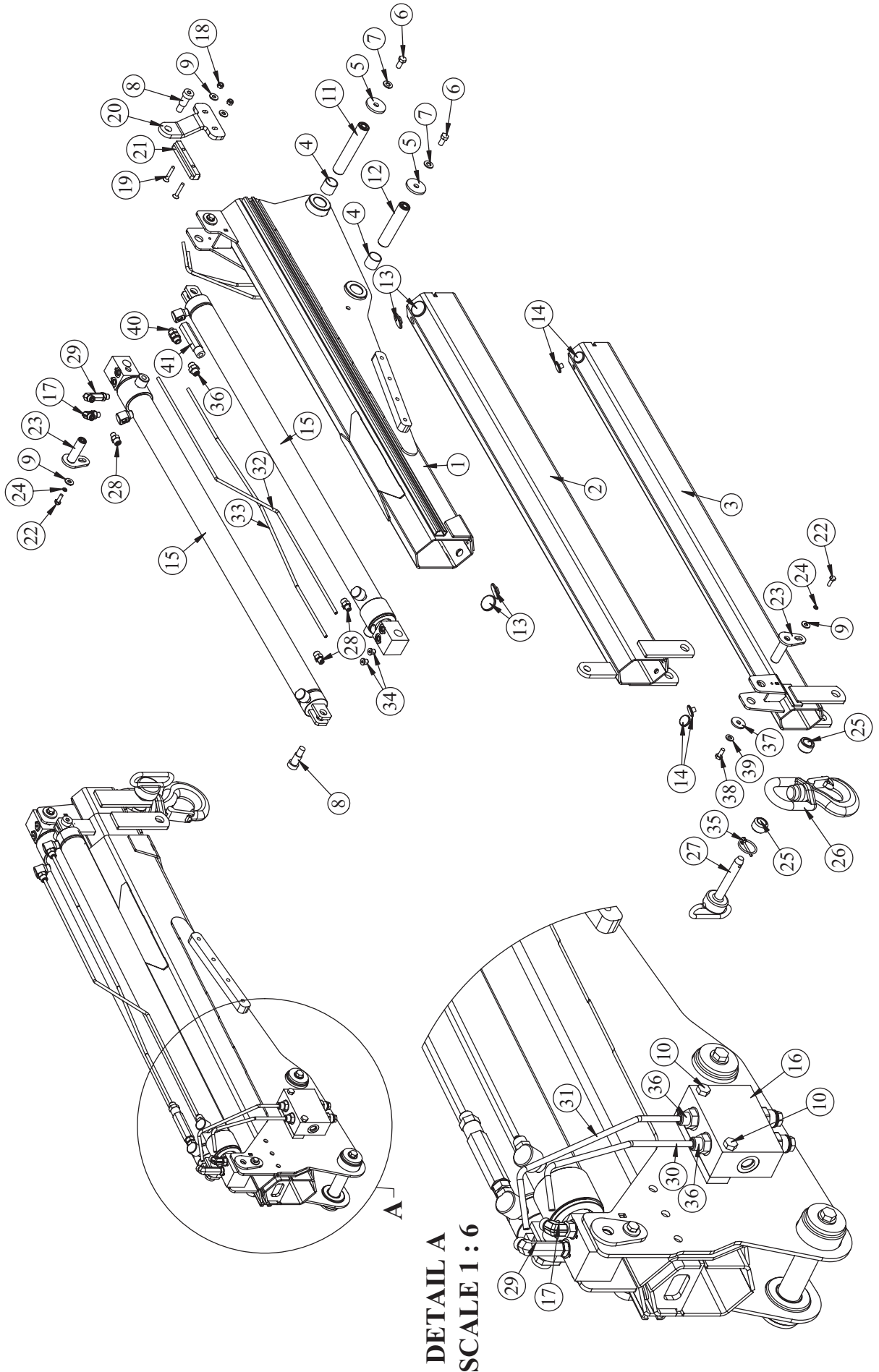

DETAIL A  
SCALE 1:6



# Boom w/ Winch Bill - PN 92671

ITEM	PART	DESCRIPTION	QTY.	ITEM	PART	DESCRIPTION	QTY.
41	92949	VALVE SEQUENCE 5 GPM	1	1	92672	INNER BOOM TC13 W/WINCH	1
				2	88989	BOOM WIDMT 1ST EXT TC13	1
				3	88990	BOOM WIDMT 2ND EXT TC13	1
				4	0069	BUSHING BPC16DXR16 1.00X1.00	4
				5	9320	PIN CAP 0.44X1.75X0.19 YZ	4
				6	9843	CAP SCR 0.38-16X0.75 HHGR8	4
				7	C6353	WASHER 0.38 SAE FLAT YELLOW GR8	4
				8	42155	BOLT SHOULDER 0.63X1.00 0.50-13X0.75	2
				9	0340	WASHER 0.25 USS FLAT	4
				10	0487	CAP SCR 0.31-18X1.75 HHGR5	2
				11	88937CR	PIN 1.00X5.38 D&T ZC	1
				12	89752CR	PIN 1.00X4.50 D&T ZC	1
				13	19457	WEAR PAD 0.16X1.38 RND	4
				14	25393	WEAR PAD 0.38X1.00 RND	4
				15	88997	CYLINDER 1.50X33.50	2
				16	89378	MANIFOLD ASM CBAL DOUBLE CBBDLJNZ4U	1
				17	C1198	FIG 4-4 MFS-MAORB 90	1
				18	0333	NUT 0.25-20 HHGR5 NYLOC	2
				19	76182	CAP SCR 0.25-20X1.50 FHSH	2
				20	90004	PLATE CYLINDER GUIDE TC13	1
				21	90120	WEAR PAD GUIDE CYL TC13	1
				22	0479	CAP SCR 0.25-20X0.75 HHGR5	2
				23	89702CR	PIN TEAR DROP .75X2.44 ZC	2
				24	0521	WASHER 0.25 LOCK	2
				25	89903	COLLAR 0.78X1.25X0.81	2
				26	25842	HOOK 3 TON SWIVEL CROSBY 1028618	1
				27	17007	PIN HITCH 0.75X4.00	1
				28	D1291	FIG 4-4 MFS-MORB STRAIGHT	3
				29	73948	FIG 4-4 MFS-MAORB 90	1
				30	90211	TUBE ASM 0.25 TC13 BOOM VALVE RETRACT ZC	1
				31	90212	TUBE ASM 0.25 TC13 BOOM VALVE EXTEND ZC	1
				32	90213	TUBE ASM 0.25 TC13 BOOM CYL EXTEND ZC	1
				33	90214	TUBE ASM 0.25 TC13 BOOM CYL RETRACT ZC	1
				34	D0511	FIG 4 MORB PLUG HOLLOW HEX	2
				35	5753	PIN 0.19X1.56 LYNCH	1
				36	C4922	FIG 4-6 MFS-MORB STRAIGHT	3
				37	92668	PIN CAP 0.38X1.25X0.14 YZ	2
				38	0420	CAP SCR 0.31-18X0.75 HHGR5	2
				39	5591	WASHER 0.31 SAE FLAT YELLOW GR8	2
				40	92067	FIG 6-4 MAORB-MORB STRAIGHT	1

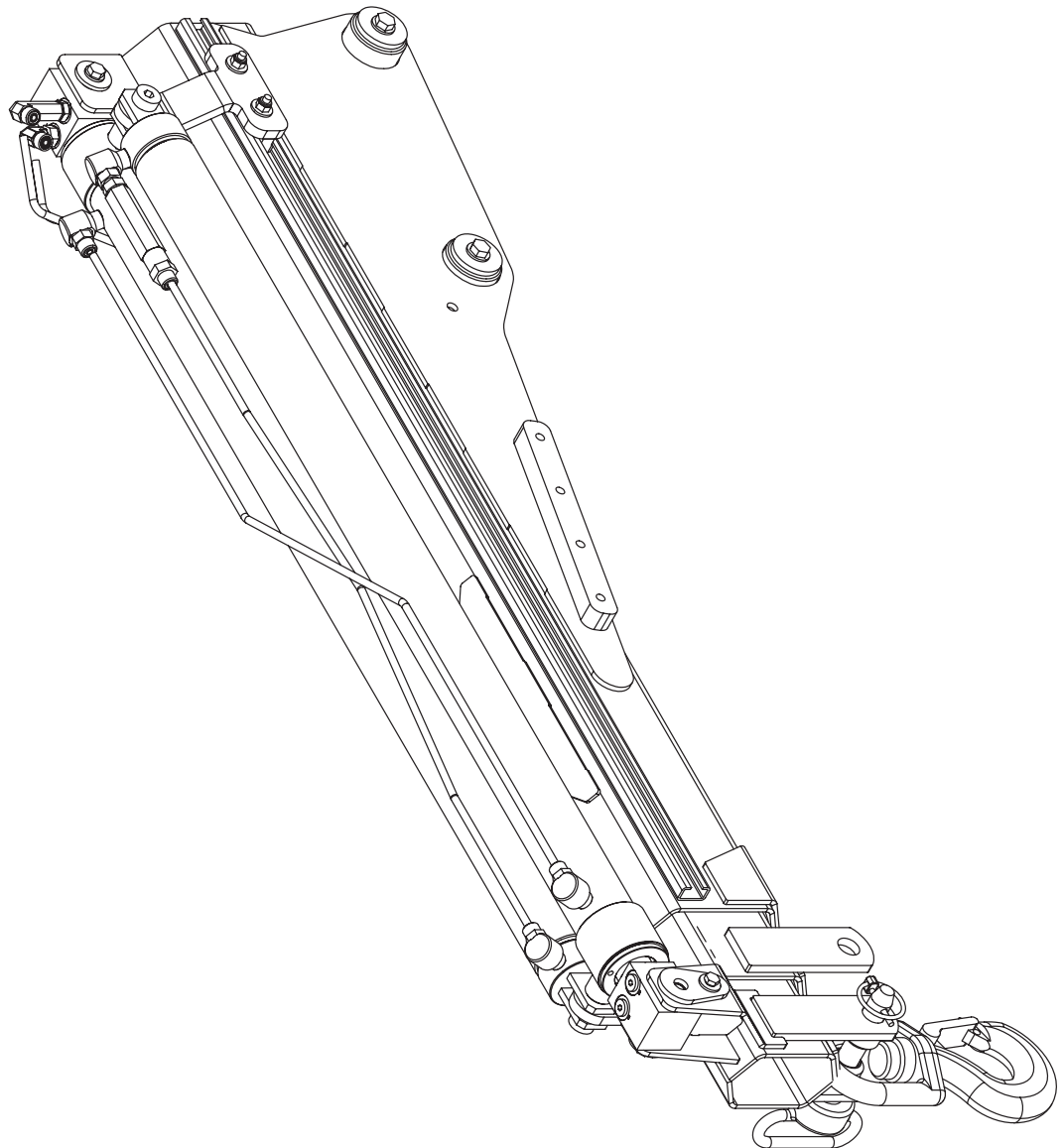

# Winch Kit Assembly - PN 75172

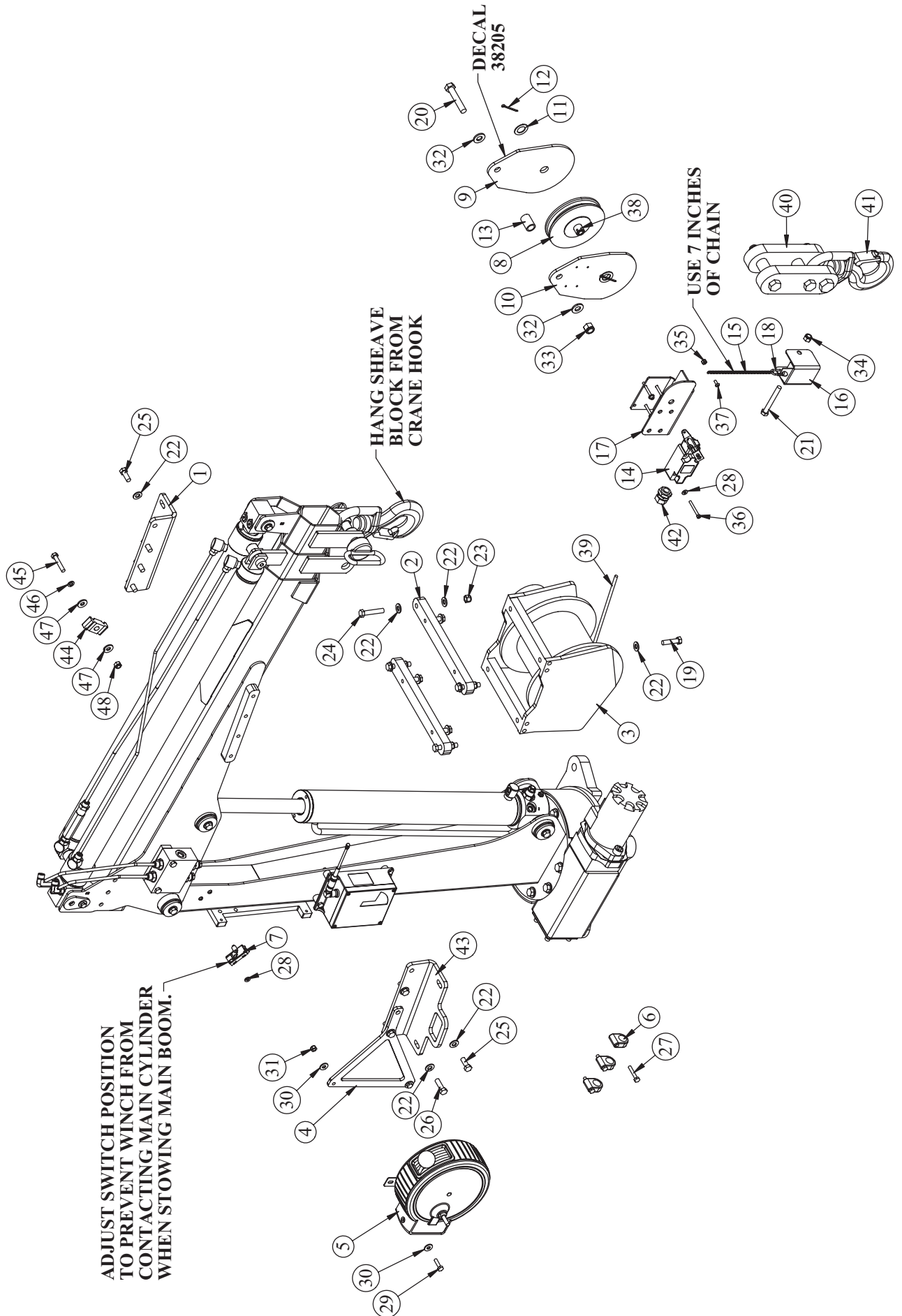

# Winch Kit Bill - PN 75172

**CRANE SHOWN FOR REFERENCE**

**SEE SHEET 2 OF INST DWG 88055  
FOR ELECTRICAL INST PARTS**

**NOT SHOWN:  
41068 DECAL VB CONTROL  
38205 DECAL LOAD BLOCK**

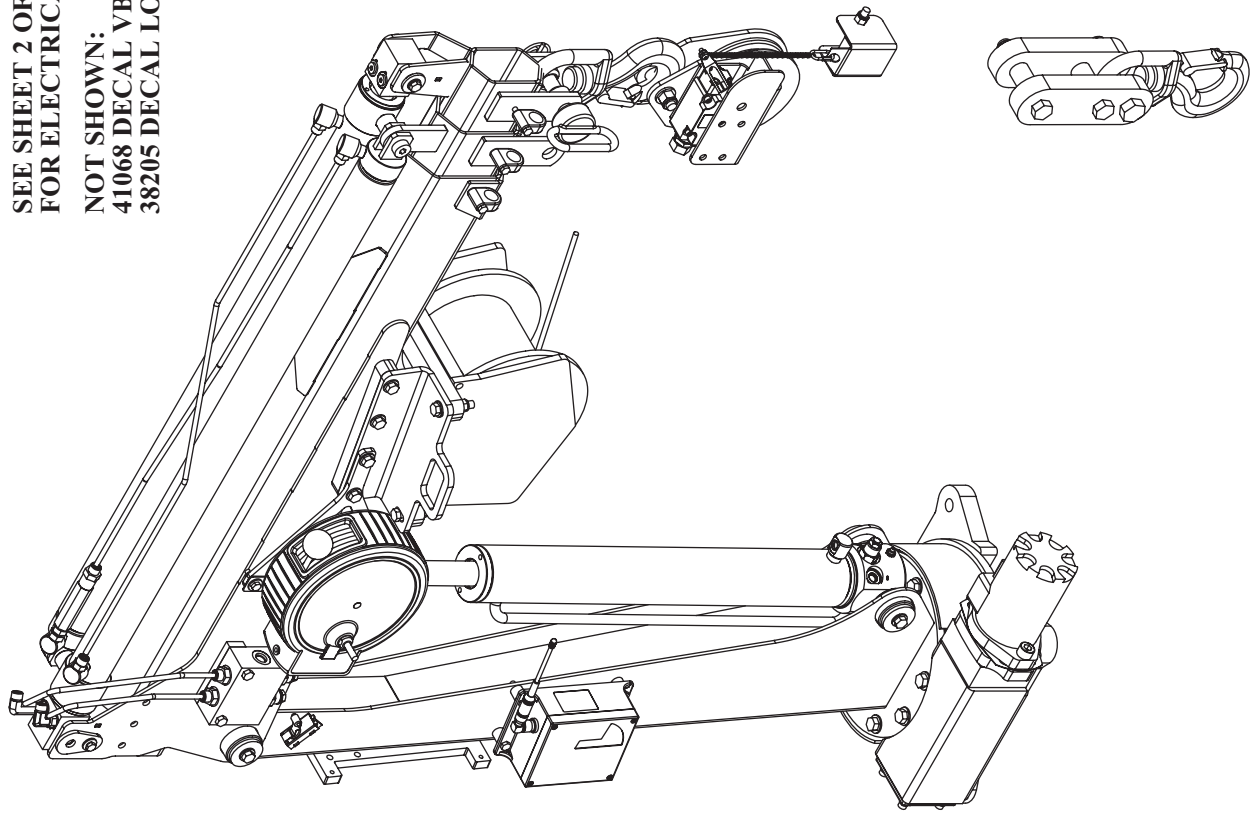

ITEM	PART	DESCRIPTION	QTY.
1	85514	ANGLE FORMED WINCH MOUNT TC23	1
2	85784	PLATE WINCH MOUNT TC CRANE	2
3	19511	WINCH 1600 3315 CRANE	1
4	92669	PLATE CORD REEL MOUNTING TC13	1
5	72602	CORD REEL ASM 15/21 FT CRANE	1
6	0337	HOSE CLAMP LN 3160 PP	3
7	35105	SWITCH LIMIT E1117-B9111-6C	1
8	16494	SHEAVE 3515 5.25 DIA .25R/1.12 THK	1
9	85786	PLATE SHEAVE ASM TC CRANE	1
10	85787	PLATE SHEAVE ASM TC CRANE	1
11	0375	MACHY WASHER 0.75ID 14GA	2
12	37824	COITER PIN .125X1.00	2
13	16607	SPACER 3315 SNATCH BLOCK	1
14	11938	SWITCH LIMIT A2B FURNAS 3SE3170	1
15	10972	CHAIN 0.105 (RM) 2607-21201	1
16	35264	WEIGHT ANTI 2 BLOCK PC RED	1
17	33081	COVER ANTI 2 BLOCK RH PC WHITE	1
18	37850	CONNECTOR QUICK LINK 0.13	1
19	16962	CAP SCR 0.38-16X1.50 HHGR8	4
20	47868	CAP SCR 0.50-13X2.75 HHGR8	1
21	C0949	CAP SCR 0.38-16X3.00 HHGR5	1
22	C6353	WASHER 0.38 SAE FLAT YELLOW GR8	20
23	56673	NUT 0.38-16 HHGR8 NYLOC	4
24	C1006	CAP SCR 0.38-16X2.00 HHGR8	4
25	13573	CAP SCR 0.38-16X1.00 HHGR8	6
26	13576	CAP SCR 0.38-16X1.25 HHGR8	2
27	0220	CAP SCR 0.25-20X1.50 HHGR5	3
28	D0178	WASHER #10 SAE FLAT	6
29	0480	CAP SCR 0.25-20X1.00 HHGR5	2
30	0340	WASHER 0.25 USS FLAT	4
31	0333	NUT 0.25-20 HHGR5 NYLOC	2
32	D0790	WASHER 0.50 SAE FLAT YELLOW GR8	2
33	5468	NUT 0.50-13 HHGR8 NYLOC	1
34	0347	NUT 0.38-16 HHGR5 NYLOC	1
35	C4956	NUT #10-24 HH NYLOC SS	1
36	33749	CAP SCR #10-24X1.75 SH	4
37	D1711	CAP SCR #10-24X0.50 BTNHD SS	1
38	42524CR	PIN 0.75X2.50 COITER ZC	1
39	17006	WIRE ROPE 1/4 7X19 GAC 65FT	1
40	39027	DOWN HAUL WEIGHT ASSEMBLY	1
41	25842	HOOK 3 TON SWIVEL CROSBY 1028618	1
42	10965	STRAIN RELIEF .50 NPT .20-.35 CABLE	1
43	85933	ANGLE FORMED WINCH MOUNT TC23 HOOK STOW	1
44	8622	CLAMP HOSE/TUBE AG-2	1
45	0487	CAP SCR 0.31-18X1.75 HHGR5	1
46	0522	WASHER 0.31 LOCK	1
47	0343	WASHER 0.31 USS FLAT	2
48	0342	NUT 0.31-18 HHGR5 NYLOC	1



Subject to Change without Notification.  
© 2018 Stellar Industries, Inc.