

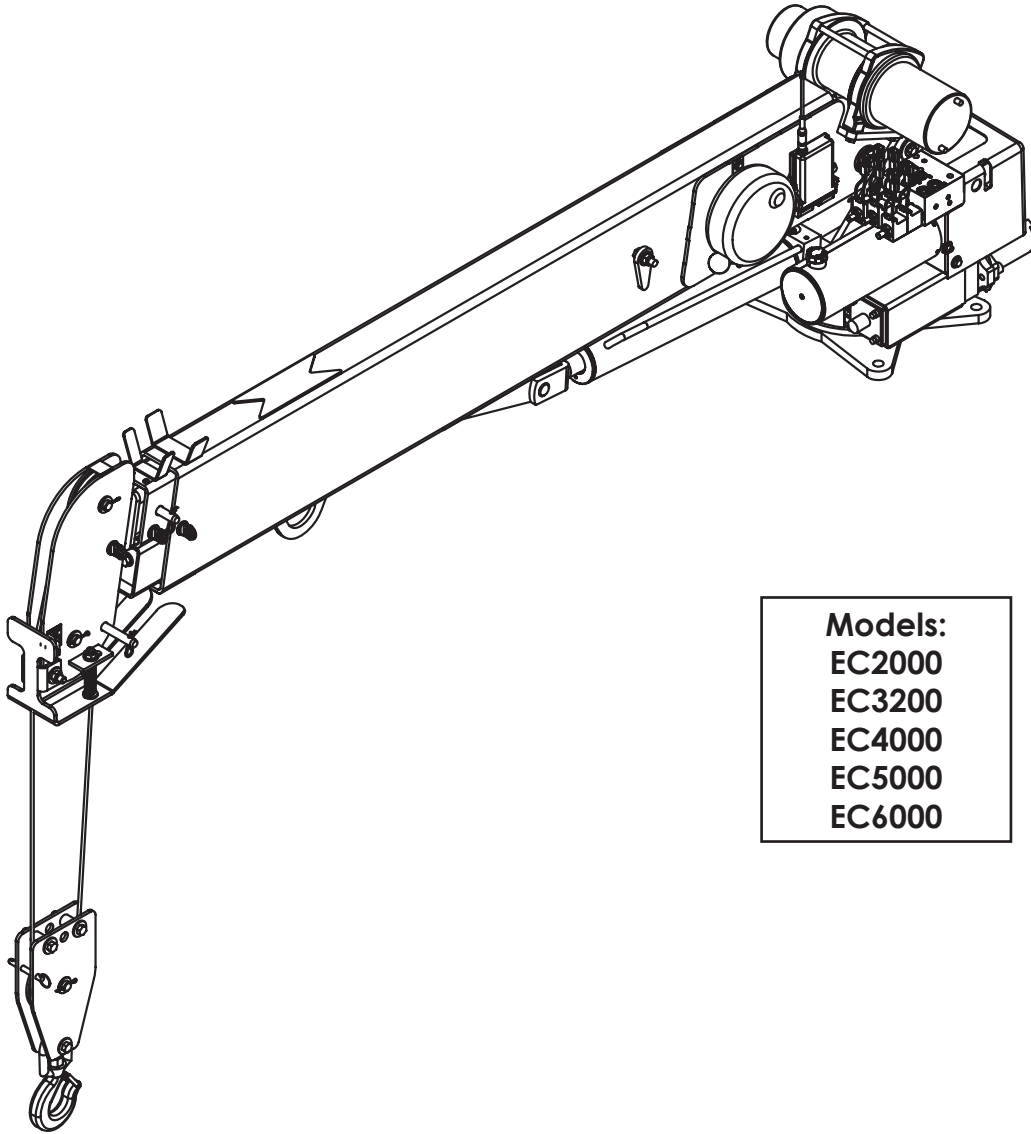

# EC SERIES CRANE

## OWNERS' MANUAL

Safety • Operation • Maintenance • Troubleshooting



Models:  
EC2000  
EC3200  
EC4000  
EC5000  
EC6000

Notice: A copy of this manual must remain with the equipment at all times.  
For a printable download copy, please visit: [www.stellarindustries.com](http://www.stellarindustries.com)

**Stellar Industries, Inc.**

190 State Street

PO Box 169

Garner, IA 50438

800-321-3741

Fax: 641-923-2811

[www.stellarindustries.com](http://www.stellarindustries.com)

Subject to Change without Notification.  
© 2017 Stellar Industries, Inc.

Rev 1  
PN 65775

# EC Series Crane Manual Revisions

Date of Revision	Section Revised	Description of Revision

**For Technical Questions, Information, Parts, or Warranty, Call Toll-Free at  
800-321-3741**

Hours: Monday - Friday, 8:00 a.m. - 5:00 p.m. CST

Or email at the following addresses:

**Technical Questions, and Information**

[service@stellarindustries.com](mailto:service@stellarindustries.com)

**Order Parts**

[parts@stellarindustries.com](mailto:parts@stellarindustries.com)

**Warranty Information**

[warranty@stellarindustries.com](mailto:warranty@stellarindustries.com)

# Table of Contents

---

Introduction.....	ii
<b>Chapter 1 - Operation .....</b>	<b>1</b>
General Operation.....	1
Pre-Operation Inspection .....	1
Job Site Setup .....	2
Step 1: Disengage drive axle and set the parking brake.....	2
Step 2: Turn on power to the crane.....	2
Step 3: Position the stabilizers.....	3
Step 4: Operate the crane.....	3
Step 5: Stow the crane.....	5
Step 6: Stow the stabilizers.....	5
Step 7: Release the parking brake.....	5
Radio Remote Control Features .....	6
Radio Remote Control Functions.....	7
Wire Rope/Sheave Configurations.....	8
Safety Decals of Note .....	9
Body/Chassis.....	9
Stabilizers .....	9
Crane Compartment.....	10
Main Boom.....	11
Crane Horse Head .....	12
Valve Bank.....	12
Main Cylinder.....	12
<b>Chapter 2 - Maintenance.....</b>	<b>13</b>
Basic Crane Maintenance Schedule* .....	13
General Maintenance Guidelines.....	13
Hydraulic Oil Maintenance .....	14
Recharging the Auxiliary Battery .....	14
Washing the Crane.....	14
Wire Rope Maintenance .....	14
Winch Maintenance .....	14
Extension Boom Maintenance .....	14
Load Hold Test Procedure .....	14
Rotation Gear Bearing Maintenance.....	15
Gear-Bearing Bolt Maintenance .....	16
Rotation Gear Bearing Thread Tightening Procedure .....	16
Torque Data Chart .....	17
Rotation Gear Bearing Tilt Test .....	18
Rotation Gear Bearing Worm End Play & Backlash.....	19
Lubrication Recommendations .....	20
<b>Chapter 3 - Troubleshooting.....</b>	<b>21</b>
Crane Hoist Troubleshooting .....	23
5 Function Hetric Radio Remote Troubleshooting.....	24
Transmitter Troubleshooting.....	25
Receiver Troubleshooting .....	25
Manual Operation.....	26

# Introduction

Stellar® Cranes are designed to provide safe and dependable service for a variety of operations. With proper use and maintenance, these cranes will operate at peak performance for many years.

To promote this longevity, carefully study the information contained in this manual before putting the equipment into service. Though it is not intended to be a training manual for beginners, this manual should provide solid guidelines for the safe and proper usage of the crane.

Once you feel comfortable with the material contained in this manual, strive to exercise your knowledge as you safely operate and maintain the crane. This process is vital to the proper use of the unit.

## A few notes on this manual:

A copy of this manual is provided with every crane and can be found in the hard plastic manual case that is installed on the chassis. A copy of this manual shall remain with the crane at all times.

Throughout the manual, three signal words will be used to bring attention to important items:

### **NOTICE**

A NOTICE signal word indicates a practice not related to physical injury.

### **⚠ WARNING**

A WARNING signal word indicates a hazardous situation which, if not avoided, could result in death or serious injury.

### **⚠ DANGER**

A DANGER signal word indicates a hazardous situation which, if not avoided, will result in death or serious injury.

Information contained within this manual does not cover all maintenance, operating, or repair instructions pertinent to all possible situations. Please be aware that some sections of this manual contain information pertaining to Stellar® manufactured cranes in general and may or may not apply to your specific model.

This manual is not binding. Stellar Industries, Inc. reserves the right to change, at any time, any or all of the items, components, and parts deemed necessary for product improvement or commercial/production purposes. This right is kept with no requirement or obligation for immediate mandatory updating of this manual.

## In closing:

If more information is required or technical assistance is needed, or if you feel that any part of this manual is unclear or incorrect, please contact the Stellar Customer Service Department by phone at 800-321-3741 or email at [service@stellarindustries.com](mailto:service@stellarindustries.com).

# Chapter 1 - Operation

Safety should be the number one thought on every operator's mind. Three factors should exist for safe operation: a qualified operator, well-maintained equipment, and the proper use of this equipment.

This chapter contains information regarding the safety and operation of Stellar® manufactured EC Series Telescopic Cranes and should be read and understood completely by everyone working with or near the crane before putting the unit into operation.

**⚠ WARNING** Failure to follow operating, maintenance, or safety instructions can result in death or serious injury.

## General Operation

It is the responsibility of the owner to instruct the operator in the safe operation of the equipment and to provide the operator with properly maintained equipment.

**⚠ WARNING** Stellar® Crane operators must conform to the qualifications specified in *ANSI B30.5 - Chapter 5-3 Operation*. Trainees or untrained persons shall be under the direct supervision of qualified persons.

Operators shall consult with the owner of the equipment regarding current safety regulations and required personal protective equipment.

Please take note that Stellar Industries, Inc. is not liable for accidents incurred by the crane because of non-fulfillment from the operator's side of current rules, laws, and regulations.

## Pre-Operation Inspection

Before operating the equipment, make sure all regular maintenance has been performed. Each day, inspect the crane for all of the following:

- Vehicle for standard checks such as proper tire inflation and fluid levels.
- Parking brake operation.
- Hydraulic reservoir for proper oil level.
- Hoses and gearboxes for evidence of oil leaks.
- Crane controls for excessive wear, cleanliness and proper operation.
- Operational aids such as decals for placement and legibility.
- All securing hardware such as cotter pins, snap rings, hairpins, and pin keepers for proper installation.
- Crane hook and other loose parts for damage to structures or weld.
- Anti-two block switch for proper function.
- Wire rope for broken wires, extensive wear, distortion, and heat damage.
- All safety guards for proper installation.
- Auxiliary crane battery (If used) for adequate charge. See Chapter 2: Maintenance for auxiliary battery recharge instructions.

Replace/repair as necessary prior to operation. For a more detailed checklist of scheduled inspection points, refer to the Stellar® Crane Inspection Log. This document is an essential guide for the daily, monthly, quarterly and annual inspection tasks that will help maintain the quality of your Stellar product.

## Job Site Setup

Thoroughly plan the lift by understanding the work site area and your loads before positioning the vehicle. For a complete and detailed description of job site setup, please refer to the AEM Safety Manual (Form C-70-2). Consider the following:

- The vehicle should be positioned in an area free from bystanders and overhead obstructions. Use a signal person if necessary.
- **⚠ DANGER** Always maintain safe clearance from high voltage power lines in accordance with *ANSI B30.5: 5-3.4.5 Operating Near Electric Power Lines*. Death or serious injury will result from inadequate clearance if crane, load, or vehicle becomes electrically charged.
- Make certain that the vehicle is parked on stable, flat ground as close to the job as possible. The surface under the service truck must be able to support the weight of the machine and its load.
- Use wheel chocks if parking the vehicle on a slope.
- Always park the vehicle with the grade. If cross-grade parking is required, the load capacity must be decreased appropriately to mitigate tipping risk.
- **⚠ WARNING** Do not operate the crane during electrical storms.
- In dusty work areas, every effort must be taken to keep dust and sand out of the moving parts of the machinery.
- In high humidity work areas, keep parts as dry as possible and well lubricated.

### Step 1: Disengage drive axle and set the parking brake.

The drive axle must be disengaged and the parking brake must be set before operating any of the equipment.

### Step 2: Turn on power to the crane.

To initiate electrical power to the crane, activate the button labeled 'Main Power', usually located in the cab of the truck.

## Step 3: Position the stabilizers.

Lower the stabilizer(s) using the hand crank located at the rear of the truck.

**⚠ WARNING** Keep clear of stabilizer legs during operation. Moving stabilizers can cause serious crushing injuries. Make certain that all personnel are clear of the stabilizer and the ground contact point before operating.

**⚠ WARNING** Do not raise the rear tires of the truck off the ground with the stabilizers. Confirm that the stabilizers are positioned on stable, flat ground and that the truck is as level as possible both front to rear and side to side. Use stabilizer pads to ensure the proper distribution of weight.

## Step 4: Operate the crane.

Operators should have a firm understanding of *ANSI B30.5 - Section 5-3.2 Operating Practices* and *AEM Safety Manual (Form C-70-2)* prior to operating of the crane.

**NOTICE** The truck should always remain running while operating the crane to maintain battery charge. Stellar recommends the use of an auxiliary battery when operating the crane indoors or in an environment that prevents to the truck from running.

### Using the Radio Remote:

To operate the crane using the radio remote control, activate the desired toggle function. The radio remote allows for simultaneous functions. With practice, it is possible to use more than one toggle at the same time (Extension Out/Winch Down for example). See the Radio Remote Control Functions and Features pages later in this chapter for more information.

### Unstowing the Crane:

To unstow the crane and prepare it for a lift:

- Winch down slightly.
- Raise the boom high enough to clear the boom rest and any other obstructions from the chassis.
- Rotate the crane until it clears the side of the truck body.
- Lower the crane boom down far enough so that the snatch block is within comfortable reach.
- Winch down to create slack in the wire rope and unhook the snatch block.

### Attaching the load:

- Position the crane with the hook centered directly over the load avoid side loading.
- Attach the load to the hook by means of slings or other approved devices.

**⚠ WARNING** Never use a sling bar or anything larger than the hook throat that could prevent the hook latch from closing. This would negate the safety feature.

- Maintain a minimum of 3 full wraps of wire rope on the winch drum at all times.

**⚠ WARNING** Do not wrap the wire rope around the load.

### Lifting the load:

Lift the load slightly off the ground to check the safety of the cargo. Consider the following:

- Make certain that the stabilizers are positioned on flat, stable ground.

**⚠ WARNING** Never exceed manufacturer's load charts and ratings. These ratings are based on the machine's hydraulic, mechanical, and structural design rather than stability.

- It is the responsibility of the operator to know the weight of both the rigging and the handled load to avoid overloading the crane. Do not rely on the overload device to determine maximum rated loads. If the crane is picking more than the maximum rated load, the overload protection device may be malfunctioning. Discontinue use immediately and contact Stellar Customer Service for support.

**⚠ WARNING** Do not use a crane to lift personnel.

- Do not attempt to lift fixed loads.

### Moving the load:

Ensure that the load is secure and balanced within the sling before moving. Consider the following:

- Be sure that the crane is level and stable before moving the load.

• Always look for any changes to the surroundings since the job site setup. Be aware of any new or missed overhead obstructions (branches, power lines, etc) and bystanders. Use a signal person if necessary.

**⚠ WARNING** Never operate the crane with personnel under any part the boom or load. Do not extend or rotate a load over anyone. Never allow personnel to place themselves under any part of the boom or load.

**⚠ WARNING** Never leave a crane load suspended or unattended.

- Do not use the boom or the winch to drag a load.



- Do not use the crane boom to push downward onto anything.
- Avoid sudden starts and stops when moving a load.
- Do not drag loads with the crane.

## Step 5: Stow the crane.

Once you have performed your lift and are ready to shut down the work site:

- Retract all extensions.
- Winch up to bring the snatch block within 3 feet of the boom tip.
- Lower the crane boom down far enough so that the snatch block is within comfortable reach.
- Hook the snatch block to the stow hook on the main boom. Maintain control to avoid personal injury or damage to any equipment.

**⚠ WARNING** Never use the stow hook for anything other than stowing the snatch block.

- Tighten the winch line so that the snatch block comes within a few inches of the main boom. Avoid activating the anti-two block switch when tightening slack.
- Raise the boom slightly above the boom rest.
- Rotate the boom counter-clockwise until it aligns with the boom rest.
- Lower the boom gently into the boom rest.
- Store the radio remote control, preferably in the cab of the truck.

## Step 6: Stow the stabilizers.

After stowing the crane, return to the stabilizer crank and fully retract the stabilizer(s).

## Step 7: Release the parking brake.

The parking brake must be released before moving the truck.

**⚠ WARNING** Make certain that any air tanks are completely drained before moving the truck.

# Radio Remote Control Features

## Radio Remote Sleep Mode

The radio remote control enters sleep mode after about 15 seconds of inactivity. Activate a toggle switch to re-link the transmitter to the receiver. After re-linking, activate the desired toggle to continue operation.

## E-Stop Button

The Radio remote control is equipped with an emergency stop button. If a situation arises that requires the immediate stoppage of crane functionality, press down on the red Emergency Stop button located in the center of the remote control.

**NOTICE** The E-stop button is not intended to be an on/off switch. This is also the first item to check if the crane is not responding to toggle and trigger activation. Make sure the red E-Stop button is in the up or disengaged position.

## Radio Remote Battery Replacement

Occasionally the batteries in the handheld transmitter will need to be changed. The AA Alkaline batteries are located in the handle portion of the radio transmitter. Release the button and slide the battery holder out. Replace the batteries and return the holder back into the handheld transmitter until the button latches.



## Radio Remote Backup Cord

If the handheld transmitter has a system problem that makes the radio function un-usable, use of the back-up cord may be necessary.

**DANGER** Death or serious injury will result from touching tethered remote if the crane, load, or vehicle becomes electrically charged. Always maintain safe clearance from high voltage power sources.

1. Locate the backup control cord. Most likely it is in the crane compartment, or in the cab behind the seat.

2. Remove the battery holder from the remote handle and place the similar looking end of the back-up cord in the bottom of the transmitter handle.



3. Attach the other end of the back-up cord to the connector currently used by the antenna on the control receiver. The control receiver is located on the back of the crane mast.



# Radio Remote Control Functions

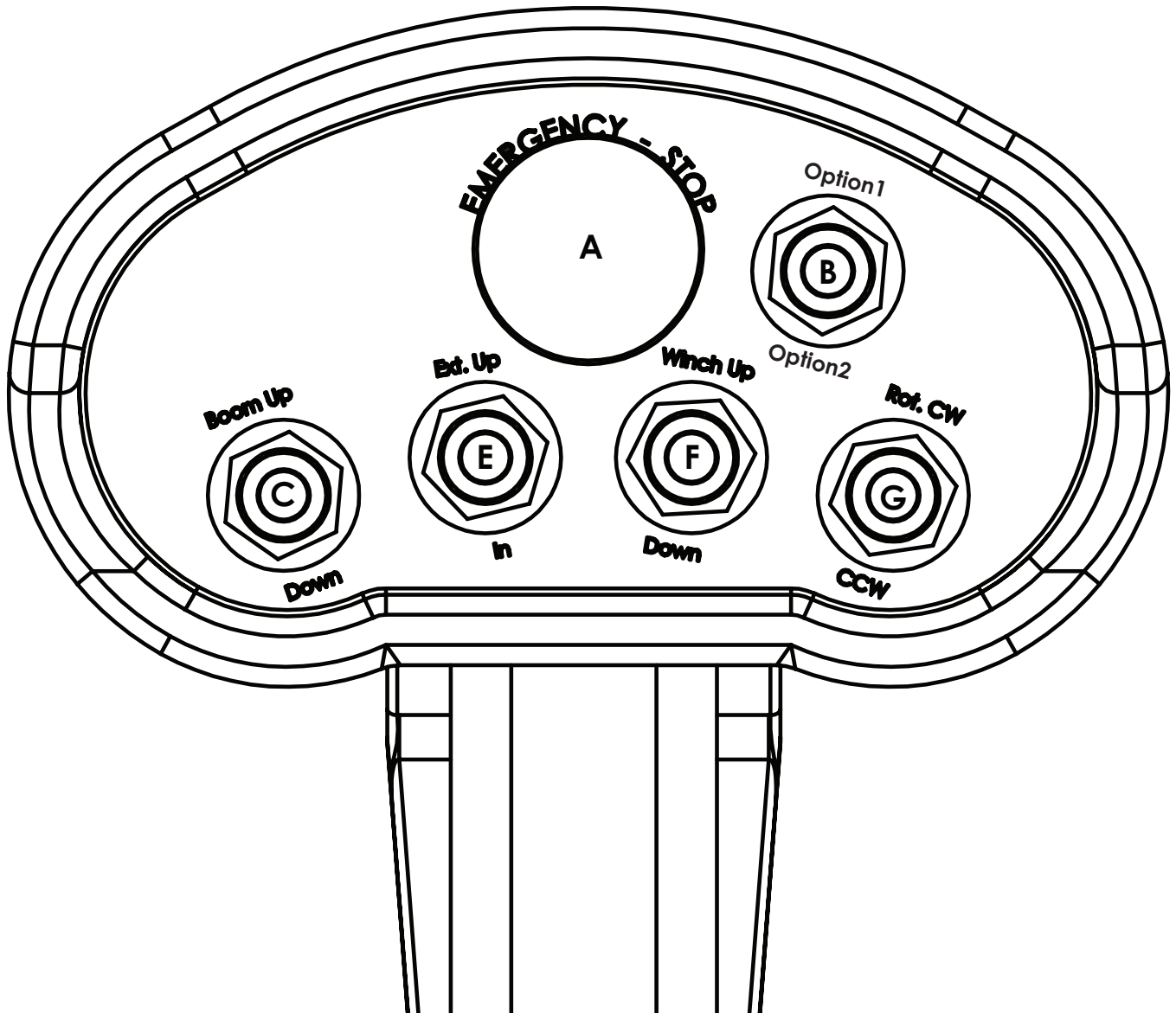

- A. E-Stop Button:** Push in/down to immediately stop all crane functionality. Pull up/out to restore functionality.
- B. Option1/Option2:** Provides signal for optional equipment
- C. Boom Up/Down Toggle:** Push up to raise the boom. Push down to lower the boom.
- D. Extension In/Out Toggle:** Push up to extend the extension. Push down to retract the extension.
- F. Winch Up/Down Toggle:** Push up to raise the winch. Push down to lower the winch.
- G. Rotate Clockwise/Counterclockwise:** Push up to rotate the boom clockwise. Push down to rotate the boom counterclockwise.

# Wire Rope/Sheave Configurations

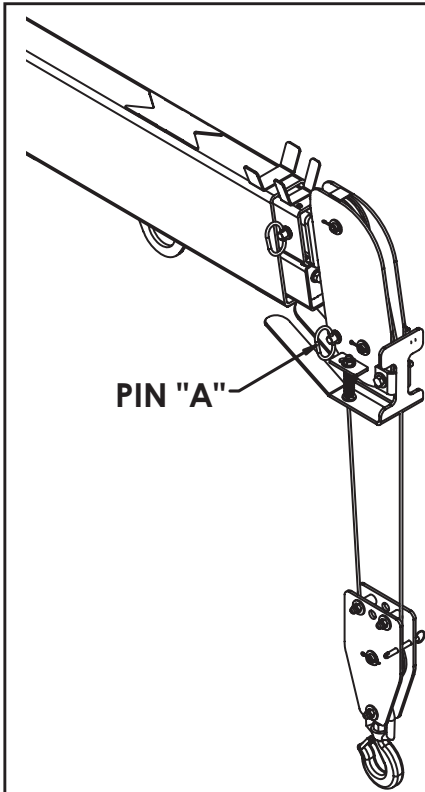

## Standard 2-Part Line

Capacities as shown on load chart.

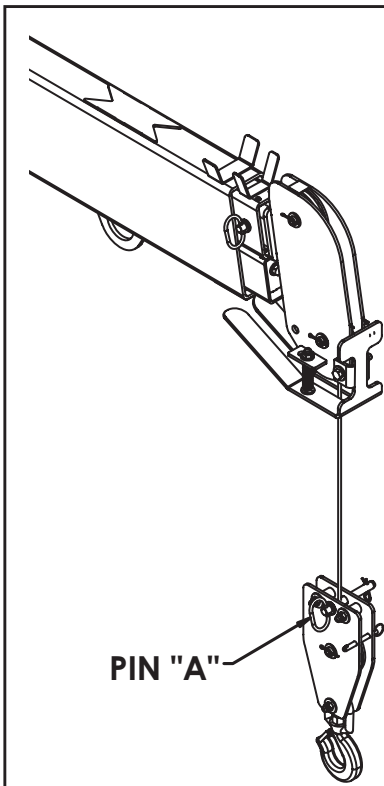

## Single Part Line

- 1) Remove PIN "A" from boom tip.
- 2) Route wire rope through snatch block.
- 3) Pin wire rope to snatch block as shown with PIN "A"

# Safety Decals of Note

Safety decals serve to inform the viewer of the hazard type, how to avoid the hazard, and the consequences of not avoiding the hazard.

Decals are considered safety equipment. They must be maintained, as would other safety devices. All safety instruction plates, notices, load charts and any other decal applied to the crane or service body must be kept legible and in good condition. Replace any decals that are missing, damaged, or illegible.

Detailed below are a number of key safety decals related to this equipment. Use the decal placement drawing in the *Installation, Assembly Drawings, and Parts Manual* to note the actual location of the safety decals on the equipment.

## Body/Chassis

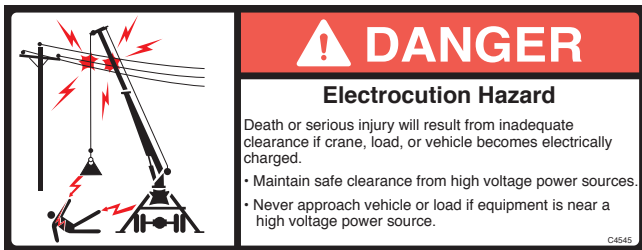

**Decal Part Number:** C4545

**Decal Location:** Four corners of the body/chassis

**Hazard Type:** Electrocutation Hazard

**Consequences:** Will result in death or serious injury.

**Avoidance:** Maintain safe clearance from high voltage power sources. Never approach vehicle or load if equipment is near a high voltage power source.

## Stabilizers



**Decal Part Number:** C4795

**Decal Location:** Each stabilizer leg

**Hazard Type:** Crush Hazard

**Consequences:** Can result in death or serious injury.

**Avoidance:** Keep clear of stabilizer legs during operation.

# Crane Compartment



## **⚠ DANGER**

### **Electrocution Hazard**

Death or serious injury will result from touching tethered remote if crane, load, or vehicle becomes electrically charged.

Maintain safe clearance from high voltage power sources.

4186

**Decal Part Number:** 4186

**Decal Location:** Crane Compartment

**Hazard Type:** Electrocution Hazard

**Consequences:** Will result in death or serious injury.

**Avoidance:** Maintain safe clearance from high voltage power sources.

## **⚠ WARNING**

### **Overload Hazard**

Do not exceed equipment load charts and ratings.

Failure to follow equipment load charts and ratings can result in death or serious injury.

4189

**Decal Part Number:** 4189

**Decal Location:** Crane Compartment

**Hazard Type:** Movement Hazard

**Consequences:** Can result in death or serious injury.

**Avoidance:** Do not exceed equipment load charts and ratings.

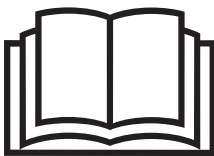

## **⚠ WARNING**

### **Untrained Operator Hazard**

Read and understand all manuals and safety signs before operating or servicing this equipment.

Failure to follow operating, maintenance, or safety instructions can result in death or serious injury.

68024



**Decal Part Number:** 68024

**Decal Location:** Crane Compartment

**Hazard Type:** Untrained Operator Hazard

**Consequences:** Can result in death or serious injury.

**Avoidance:** Read and understand all manuals and safety signs before operating or servicing equipment.

# Main Boom



## ⚠️ WARNING

### Fall Hazard

Hoisting personnel on boom, hook, load, or loadline can result in death or serious injury.

- Never use crane to hoist personnel.
- Never ride the boom, hook, load, or any device attached to crane boom or load line.

12451

**Decal Part Number:** 12451  
**Decal Location:** Main Boom  
**Hazard Type:** Fall Hazard  
**Consequences:** Can result in death or serious injury.  
**Avoidance:** Never use the crane to hoist personnel. Never ride the boom, hook, load, or any device attached to the crane boom or load line.

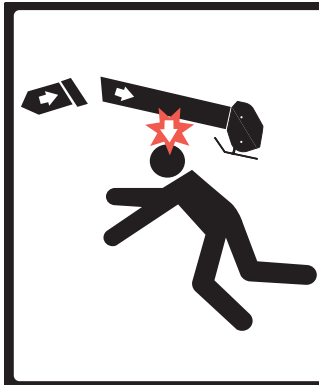

## ⚠️ WARNING

### Free Falling Boom Hazard

Free falling manual boom extensions can result in death or serious injury.

- Properly install retention pins prior to operation.
- Do not stand in front of extension when removing retention pin.
- Do not allow extensions to free fall.

12452

**Decal Part Number:** 12452  
**Decal Location:** Main Boom  
**Hazard Type:** Free Falling Boom Hazard  
**Consequences:** Can result in death or serious injury.  
**Avoidance:** Properly install retention pins prior to operation. Do not stand in front of extension when removing retention pin. Do not allow extensions to free fall.

## ⚠️ WARNING

### Misuse Hazard

Do not use stow hook for any lifting applications.

Using the stow hook for anything other than hook stowage can result in death or serious injury.

24712

**Decal Part Number:** 24712  
**Decal Location:** Main Boom  
**Hazard Type:** Misuse Hazard  
**Consequences:** Can result in death or serious injury.  
**Avoidance:** Do not use stow hook for any lifting applications.

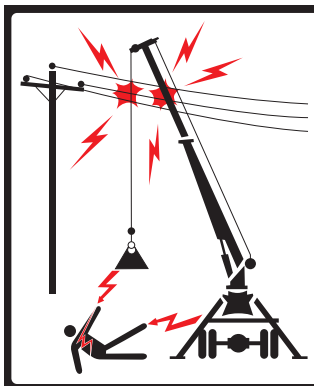

## ⚠️ DANGER

### Electrocution Hazard

Death or serious injury will result from inadequate clearance if crane, load, or vehicle becomes electrically charged.

- Maintain safe clearance from high voltage power sources.
- Never approach vehicle or load if equipment is near a high voltage power source.

C1179

**Decal Part Number:** C1179  
**Decal Location:** Main Boom  
**Hazard Type:** Electrocution Hazard  
**Consequences:** Will result in death or serious injury.  
**Avoidance:** Maintain safe clearance from high voltage power sources. Never approach vehicle or load if equipment is near a high voltage power source.

## Crane Horse Head

**WARNING**

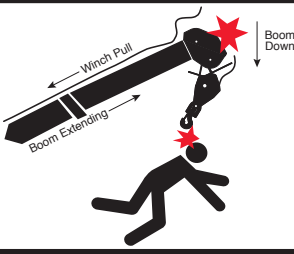

**Misuse Hazard**

Two blocking the crane can result in death or serious injury.

Never allow the hook block to contact the boom tip by hoisting up, extending or lowering the boom.

12300

**Decal Part Number:** 12300

**Decal Location:** Crane Horse Head

**Hazard Type:** Misuse Hazard

**Consequences:** Can result in death or serious injury.

**Avoidance:** Never allow the hook block to contact the boom tip by hoisting up, extending or lowering the boom.

## Valve Bank

**WARNING**

**Movement Hazard**

After stowing the crane, always return the valve bank manual overrides to the neutral position.

Failure to return the manual overrides to the neutral position can result in death or serious injury.

25159

**Decal Part Number:** 25159

**Decal Location:** Valve Bank

**Hazard Type:** Movement Hazard

**Consequences:** Can result in death or serious injury.

**Avoidance:** After stowing the crane, always return the valve bank manual overrides to the neutral position.

## Main Cylinder

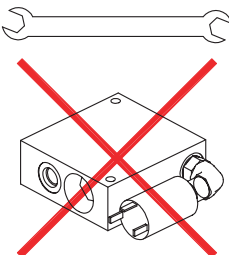

**WARNING**

**Overload Hazard**

Bypassing the overload condition by tampering with the overload device can result in death or serious injury.

Never tamper with overload device.

28256

**Decal Part Number:** 28256

**Decal Location:** Main Cylinder

**Hazard Type:** Overload Hazard

**Consequences:** Can result in death or serious injury.

**Avoidance:** Never tamper with the overload device.



# Chapter 2 - Maintenance

Maintenance is an important part of extending the life of any Stellar® Telescopic Crane. Performing key maintenance items on a scheduled program will prevent unnecessary downtime.

## Basic Crane Maintenance Schedule\*

Maintenance Operation	Daily	Weekly	Monthly	Hourly
Check hydraulic reservoir oil level.	X			
Grease rotation gear inner race bearings.		X		
Grease rotation gear worm drive bearings.			3 months	
Grease rotation gear open gear teeth.			X	
Grease all cylinder pivot points.			X	
Lubricate extension booms.			X	
Check winch gear grease level.			X	
Drain and replace hydraulic oil.				6500
Tighten all hydraulic lines.			6 months	

\* For a more detailed outline of scheduled inspection points, refer to the Stellar® Crane Inspection Log. The Stellar® Crane Inspection Log is an essential guide for the daily, monthly, quarterly and annual inspection tasks that will help maintain the quality of your Stellar product.

## General Maintenance Guidelines

Before performing any maintenance to the crane, consider the following:

- ⚠ WARNING** Only qualified service personnel are to perform maintenance on the crane. Never modify or alter any of the equipment, whether mechanical, electrical, or hydraulic, without explicit approval from Stellar Industries.
- Position the crane where it will be out of the way of other operations or vehicles in the area.
- Lower the boom fully or stow in the cradle to prevent uncontrolled movement.
- Place all controls in the off position and secure operating features from inadvertent motion.
- Before any service or repair is performed, shut off the engine.
- Before performing any maintenance on electrical components, disconnect the power source.
- Before performing any maintenance on hydraulic components, relieve hydraulic oil pressure from all hydraulic circuits. Move pedals and control levers repeatedly through their operating positions to relieve all pressures.
- ⚠ WARNING** Do not disconnect hydraulic hoses while there is still pressure in those components.
- Replace parts with Stellar® approved parts only.
- Keep the crane and service body clean and free from grease build-up, oil and dirt to prevent slippery conditions.

- Label or tag parts when disassembling.
- Immediately repair or have repaired any components found to be inadequate.

## Hydraulic Oil Maintenance

Add hydraulic oil as needed. Stellar Industries recommends the hydraulic oil be changed after 6,500 hours.

## Recharging the Auxiliary Battery

To recharge the auxiliary battery, engage the battery charge switch (located in the truck cab or the crane box) while the truck is running. When operating the crane while the truck is not running, disengage the battery charge switch to prevent the crane from draining the main truck battery.

## Washing the Crane

Important: Prior to washing the Stellar crane, the radio remote receiver located on the crane must be covered to prevent any water from entering the plastic housing. Avoid any direct water pressure to the radio remote receiver.

## Wire Rope Maintenance

Proper maintenance is key in ensuring a long lasting rope. Refer to ANSI B30.5 for details on maintaining your wire rope.

## Winch Maintenance

Refer to winch manual supplied with crane.

## Extension Boom Maintenance

While operating the crane, extend and retract the extension booms. If the extension weldments are noisy during operation, it is necessary to lubricate the booms. Stellar® Model Cranes feature a metal coating which will require an aerosol lubricant. Stellar Industries recommends aerosol style lubricant Stellar PN 44512.

## Load Hold Test Procedure

Fully extend a load (65-70% of crane's rated capacity) at a boom angle of approximately 60°. With the load at 3-5 inches off the ground, use a tape measure to mark the load from a specific flat/level spot on the ground (Note: Use a board/pad if necessary). Also at this time, use a grease pen to make a temporary mark on the main cylinder rod and another mark on the winch drum in reference to the housing. Finally, measure the stabilizer legs from the ground.

After waiting five minutes, measure the load from the same specific spot on the ground. If the load movement is within 1/4", the test has passed. If the load has moved more than 1/4", wait another five minutes and re-measure. If the load continues to move, check the other marks (main cylinder rod, winch drum) and re-measure the stabilizers to narrow down the potential drifting issue. Please refer to the troubleshooting section at the end of this manual for further detailed instructions.

# Rotation Gear Bearing Maintenance



## Rotation Worm Gear and Open Gear Teeth

Use a heavy Moly Lube grease (Stellar PN 4460) to lubricate the worm gear and open gear teeth of the rotation bearing. Slowly rotate the crane while pumping the grease between the worm and rotation gear. This should be greased every month or sooner depending on the usage of the crane. Another way of applying the grease would be to remove the gear guard and brush the Molube grease between the gear teeth of the rotation bearing.

### NOTICE

Do not lubricate the worm and rotation gear teeth with EP2 grease. EP2 grease will wipe the Molube grease clean causing excessive wear.



## Worm Gear Bearings and Races

Apply three (3) pumps of EP2 grease to the two grease zerks located on the side of the Rotation Gear bearing; every three months. After adding the EP2 grease, rotate the crane fully.



## Inner Gear Bearing Race

To lubricate the inner race of the large rotation gear bearing, open the compartment door just below the crane. The grease zerk for the inner race bearing is located on the compartment drip tray. The inner race will need to be lubricated with EP2 Grease weekly. The first week grease the inner race bearing at the one (1), three (3), five (5), seven (7), nine (9), and eleven (11) o'clock positions. The following week, grease the inner race bearing in the two (2), four (4), six (6), eight (8), ten (10) and twelve (12) o'clock positions. Rotate lubrication points every week.

# Gear-Bearing Bolt Maintenance

Once a bolt has been torqued to 75% of its proof load and then removed, the torque coefficient may no longer be the same as when the bolt was new thus giving indeterminate damp loads after torquing.

**⚠ WARNING** Anytime a gear-bearing bolt is removed, it must be replaced with a new bolt of the identical grade and size.

**NOTICE** Always use Red Loctite Threadlocker sealant to secure the new bolt.

## Rotation Gear Bearing Thread Tightening Procedure

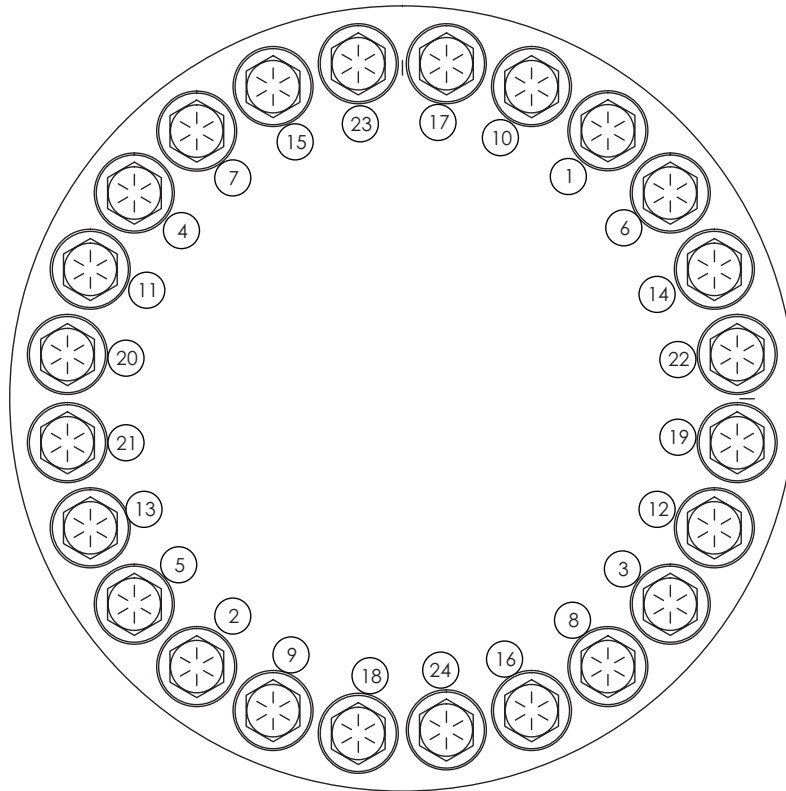

**Step 1:** Refer to the Torque Data Chart on the previous page to determine the proper torque value based on the size of bolt used.

**Step 2:** Torque all bolts to approximately 40% of the specified torque value using the tightening sequence shown above. Note: The number of bolts may be different than shown in the diagram but the sequence will work using the same pattern in relation to Bolt #1.

**Step 3:** Torque all bolts to 75% of the specified torque value using the tightening sequence shown above.

**Step 4:** Torque all bolts to the listed torque value using the tightening sequence shown above.

# Torque Data Chart

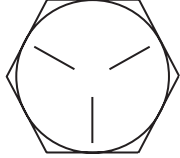
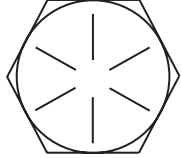
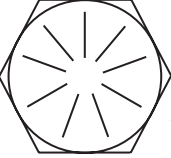
		<b>GRADE 5</b>		<b>GRADE 8</b>		<b>GRADE 9</b>
						
<b>Size (DIA-TPI)</b>	<b>Bolt DIA (Inches)</b>	<b>Plain (Ft-Lb)</b>	<b>Plated (Ft-Lb)</b>	<b>Plain (Ft-Lb)</b>	<b>Plated (Ft-Lb)</b>	<b>Plated (Ft-Lb)</b>
5/16-18	0.3125	17	13	25	18	22
3/8-16	0.3750	31	23	44	33	39
7/16-14	0.4375	49	37	70	52	63
1/2-13	0.5000	75	57	105	80	96
9/16-12	0.5625	110	82	155	115	139
5/8-11	0.6250	150	115	220	160	192
3/4-10	0.7500	265	200	375	280	340
7/8-9	0.8750	395	295	605	455	549
1-8	1.000	590	445	910	680	823
1 1/8-7	1.1250	795	595	1290	965	1167
1 1/4-7	1.2500	1120	840	1815	1360	1646
1 3/8-6	1.3750	1470	1100	2380	1780	2158
1 1/2-6	1.500	1950	1460	3160	2370	2865

When using the torque data in the chart, the following rules should be observed:

- Bolt manufacturer's particular specifications should be consulted when provided.
- Flat washers of equal strength must be used.
- All torque measurements are given in foot-pounds. To convert to inch-pounds, multiply by 12.
- Torque values specified are for bolts with residual oils or no special lubricants applied. If special lubricants of high stress ability, such as Never-Seez compound graphite and oil, molybdenum disulphite, colloidal copper or white lead are applied, multiply the torque values in the charts by the factor .90. The use of Loctite does not affect the torque values listed above.
- Torque values for socket-head capscrews are the same as for Grade 8 capscrews.



# Rotation Gear Bearing Tilt Test

**Step 1:** Place crane in vertical position.

**Step 2:** Place a dial indicator on the pinion cover plate at the back side of the mast.

**Step 3:** Set the dial indicator to 0.

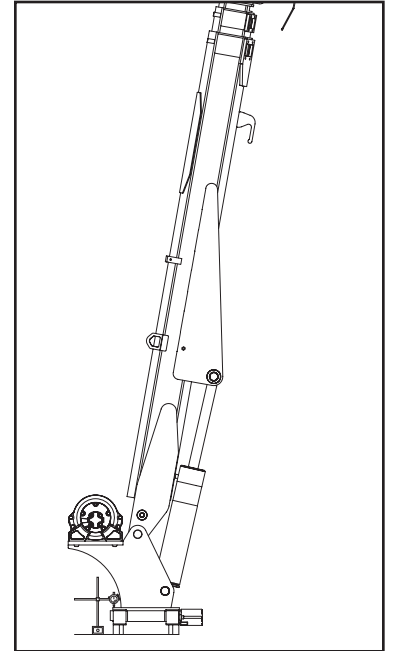

**Step 4:** Lower the crane to the horizontal position.

**Step 5:** Check and record the dial indicator change. It should not exceed the following tilt measurements:

- Stellar Models EC3200-EC6000 = 0.060" (1.524 mm)

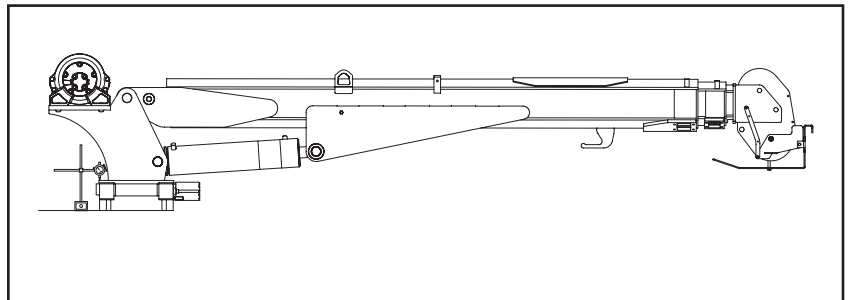

**Step 6:** Return the crane to vertical position. The dial indicator should return to calibration.

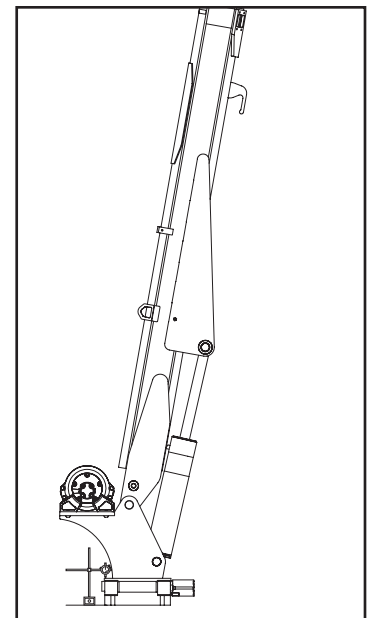

# Rotation Gear Bearing Worm End Play & Backlash

Stellar® Telescopic Cranes have an integral base and worm drive rotation system.

Backlash is the shortest distance between non-driving tooth surfaces in mating gears. Measure backlash using a feeler gauge at or near the pitch diameter and tangent to the gear.

## Locate High Tooth

To set both Worm End Play and Backlash, first locate the high tooth on the gear. This spot is marked by the manufacturer with light blue paint. If the paint mark cannot be found, use a dial indicator with a magnetic base and a round steel pin large enough to contact the bearing near the pitch line of the bearing tooth to locate the high tooth:

**Step 1:** Set the indicator base on the face of the bearing race with no teeth.

**Step 2:** Place the pin between two of the teeth.

**Step 3:** Set the indicator probe on the pin and adjust the dial to zero.

**Step 4:** Rotate the bearing, checking every third tooth until you find the highest indicator reading.

**Step 5:** Check three teeth in both directions in this area to determine the highest tooth. The amount of run-out varies depending on the diameter of the bearing.

**Step 6:** Once you find the high tooth, mark it for future reference.

## Set Worm End Play

**Step 1:** Locate the high tooth on the gear (See above)

**Step 2:** Screw a bolt into the threaded hole nearest the high tooth. Screw additional bolts into threaded holes at 90° from the high tooth.

**Step 3:** Mount a magnetic base with an indicator attached on top of the worm housing and at the opposite end from the motor mount.

**Step 4:** Adjust the indicator to read from the end of the worm shaft. Set the indicator to 0.

**Step 5:** Using two of the bolts as handles, rotate the outer race back and forth. Read the total indicator movement. This measurement is the end play of the worm. The specification for end play is +0.000/-0.004" (+0.000/-0.1016mm). If end play does not meet this specification, remove the bearing retainer and add or remove shims from the unit. Repeat this procedure until the end play meets specification.

## Set Gear Bearing Backlash

**Step 1:** Locate the high tooth on the gear (See above)

**Step 2:** Rotate the bearing until the high tooth is engaged with the worm. Loosen the three bearing retaining allen head bolts just enough to be able to move the bearing toward or away from the worm. Screw a bolt into the threaded hole in the bearing nearest the worm.

**Step 3:** Set the magnetic indicator base on the worm housing with the indicator probe against the bolt. Set the indicator dial to zero.

**Step 4:** Move the bearing back and forth. Watch the indicator dial and adjust the bearing in or out of the worm until the total indicator movement is 0.005" (0.127 mm). Notice: Be sure to deduct any end play in the worm from the indicator reading.

**Step 5:** Rotate the bearing 180°. Recheck the backlash. The total backlash should be 0.005" to 0.012" (0.127 to 0.3048 mm).

**Step 6:** After setting the backlash, torque the bearing retaining allen head bolts while watching the indicator dial so the correct backlash setting is maintained. Use the Torque Data Chart and Rotation Gear Bearing Thread Tightening Procedure for specifications.

# Lubrication Recommendations

## Crane Lubrication

Component	Location	Recommendation
Hydraulic System	Reservoir	
	Below -5°F	High VI, low pour, ISO 22, AW hydraulic oil
	-5°F to 90°F	High VI, low pour, ISO 32, AW hydraulic oil
	Above 90°F	ISO 46, AW hydraulic oil
Open Gear Teeth	Crane Rotation Gear	Moly Grease 936SF Heavy (Stellar PN 4460)
Worm Drive Bearings (including turntable bearing inner race)	Crane Rotation Gear, Inside Crane Compartment	EP2 Lithium Complex Grease (Stellar PN 78090)
Cylinders	Crane Pivot Areas	EP2 Lithium Complex Grease (Stellar PN 78090)
Crane Pins & Bushings	Crane Pivot Points	EP2 Lithium Complex Grease (Stellar PN 78090)
Wear Pad Lubrication	Extension Booms	Synthetic lubricant containing Teflon®

## Compressor Lubrication

Component	Location	Recommendation
Reciprocating Single Stage	Compressor Crankcase	ISO 100 compressor oil
Reciprocating Double Stage	Compressor Crankcase	ISO 100 compressor oil
Screw Compressor	Compressor Crankcase	
	-15°F to 86°F	Synthetic performing ISO 32 compressor oil
	-23°F to 100°F	Synthetic performing ISO 46 compressor oil
	32°F to 113°F	Synthetic performing ISO 68 compressor oil

**Greasing the Crane**  
**Lubricate all grease gun points with**  
**Extreme Pressure Grease - Stellar P/N: 22059.**



# Chapter 3 - Troubleshooting

This chapter will list a number of potential problems that may occur. Most problems are easily solved using the solutions portion of this manual. If you are unable to solve a problem, please contact Customer Service at Stellar Industries 1-800-321-2222.

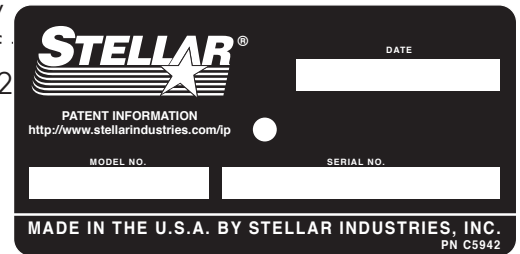

## Prior to troubleshooting:

Always make sure the emergency brake is engaged.

To determine if there is an electrical or hydraulic problem, first manually operate the crane. This is done by pushing the manual override button on the solenoid valves located along the valve bank (See the manual operation procedure page at the end of this chapter). If the crane operates, there will be an electrical problem to trace. If the crane does not operate using the manual overrides, there is a problem within the hydraulic circuit.

## Problem: Crane will not operate.

### Solutions:

- Make sure that the parking brake is engaged.
- Make sure that there is electrical power going to the radio receiver. If there is no power going to the receiver, trace back to the power source and check for a blown fuse or loose ground connection. Refer to radio remote troubleshooting guide at the end of this chapter.
- Make sure that the transmitter batteries are fully charged.

## Problem: Crane will operate manually but will not operate by radio remote.

### Solutions:

- Make sure that there is electrical power going to the radio receiver. If there is no power going to the receiver, trace back to the power source and check for a blown fuse or loose ground connection. Refer to radio remote troubleshooting guide at the end of this chapter.
- Make sure that the parking brake is engaged.
- Make sure that the parking brake switch is working properly. Check the parking brake switch by performing a continuity test. If the switch is defective, simply replace it.

## Problem: Not all crane functions operate using the radio remote transmitter or crane operates intermittently.

### Solutions:

- Make sure that the toggle switch on the transmitter is working properly. If the switch is defective, simply replace it.
- Make sure that there is power going to the valve bank coil solenoid of the function that will not operate. If no power is going to the coil solenoid, check wiring connections on wire harness plug connector for broken wires, loose connection or poor crimp. If power is going to the solenoid valve, it may not be opening to allow hydraulic oil to the function that is not operating. Remove stem valve, thoroughly clean, lubricate, and reinstall valve. Do not over tighten. If the valve will not close, simply replace it.

## Problem: Two functions operate at the same time while only toggling one function.

### Solutions:

- Make sure that the solenoid valves are all latched in the center position to ensure that they do not move while operating the crane.
- Determine the function that is operating on its own. Check to see if there is power going to the solenoid valve from a function that should not be operating. If voltage is present at the

solenoid valve without operating the function, the toggle switch has failed and is stuck in the “on” function. If no voltage is present, the solenoid valve may be partially open. Remove the stem valve, thoroughly clean, lubricate, and reinstall the valve. Do not over tighten. If valve will not close, simply replace it.

**Problem: Winch will not lift load.**

**Solutions:**

- Make sure that the object being lifted does not exceed the rated capacity of the winch. Refer to the capacity chart. If the object is within the rated capacity, reposition the truck and try to lift the object without using the crane boom extensions. Refer to “Crane Hoist Troubleshooting” later in this chapter.

**Problem: Crane operates slowly.**

**Solutions:**

- Check the level of hydraulic fluid in the reservoir. Add fluid as needed.
- Check hydraulic fluid temperature.

**Problem: Winch “Up”, Main Cylinder “Down”, and Extension Cylinder “Out” are the only functions that don’t operate.**

**Solutions:**

- Make sure that the anti-two block limit switch on the end of the boom is adjusted properly or operating per adjustment (If applicable).
- Make sure that the limit switch is working properly. Disconnect the two wires connected to the limit switch and tie them together. If all functions operate, replace the limit switch.
- Make sure that the cord for the cord reel is undamaged. Check the continuity of the cord. Disconnect the cord reel from the crane harness and bypass the harness connection. If the crane operates properly, replace cord reel.

**Problem: Cylinder drifts outward or downward.**

**Solutions:**

- Check to see if there is air in the hydraulic system. Operate all cylinders connected to the hydraulic system. Start with the extension cylinder, then operate the main boom, winch, rotation, and ending with the hydraulic stabilizers, if installed. When operating, extend each cylinder halfway out, retract all the way in, and then extend until the cylinder rod is at the end of its stroke. Operate cylinders slowly so air is pushed thru the system to the reservoir. Repeat this cycle 2-3 times.
- Make sure the holding valves are operating properly. Note: Before performing any maintenance on hydraulic components, relieve hydraulic oil pressure from all hydraulic circuits. Remove, clean, and then inspect each holding valve. When removing a holding valve, always relieve the pressure inside the cylinder by loosening jam nut of the holding valve and turning set screw inward/clockwise. Count the number of turns until the set screw is seated. When reinstalling the holding valve, make sure the valve is reset by turning the set screw the number of turns it took to relieve the pressure. Finish by tightening the jam nut.
- Check the cylinder rod for scratches. If a scratch is located on the cylinder rod, hydraulic fluid can pass thru and cause a loss of pressure. Replace cylinder rod or cylinder.
- Check to see if the piston seals are damaged. If they show signs of damage, install a new cylinder seal kit.

# Crane Hoist Troubleshooting

For detailed information on the crane hoist, please refer to the *WARN Industrial Hoists Installation and Operator's Guide (WARN PN 72561 A1)*.

PROBLEM	PROBABLE CAUSE	CORRECTION
Hoist won't operate in either direction or motor doesn't operate.	Power is not connected..	Check wiring connections. Check for electrical power at positive terminal on controller. Check for voltage on the controller terminals with remote switch in either direction.
	Emergency on/off switch (optional) is in "off" position.	Check position of emergency on/off switch (optional).
Hoist will power-out but not power-in.	Failure of components or wiring inside controller.	Check for electrical power at center pin of remote socket on controller. Check continuity of remote lead connector from center pin to either side pin with remote control on/off switch in both positions.
	Hoist Relay is malfunctioning.	Replace relay if defective.
Hoist will power-in but not power-out.	Power to remote control pendant has been interrupted.	Check for electrical power at center pin of remote socket on controller. Check continuity of remote lead connector from center pin to either side pin with remote control on/off switch in both positions. Check continuity on crane wiring harness.
Motor tries to power-out but hoist stalls or locks up.	Load brake failure.	Service or replace load brake.
Hoist operates in both directions but will not lift rated load.	Low voltage at hoist.	Be sure wiring cable size guidelines have been met.
		Check condition of battery.
		Check all power wiring and connections for corrosion. Clean and tighten connections.
Hoist slows down and stalls during power-out.	Brake needs servicing.	Service or replace load brake.
Hoist vibrates badly or is noisy during lifting or lowering of load.	Brake needs servicing.	Service or replace load brake.
	Mounting surface is not flat. Tie rod or tie bar is bent.	Check to make sure mounting surface is flat to within +/- 0.020 in. (0.50 mm). Replace tie rod or tie bar if necessary. Check for bent or cracked housings.

# 5 Function Hetric Radio Remote Troubleshooting

If the system does not operate after normal start-up, follow the recommended troubleshooting sequence to help isolate the cause and determine corrective action.

<b>Transmitter</b> <ul style="list-style-type: none"> <li>• Is the E-Stop push button pulled out?</li> <li>• Are all the switches in their center (neutral) position.</li> <li>• Are the batteries in the transmitter fully charged?</li> <li>• Is the transmitter inside its operating range?</li> </ul>	<b>Receiver</b> <ul style="list-style-type: none"> <li>• Is the antenna plug securely connected?</li> <li>• If there is an external antenna, is the antenna connection assembly outside the enclosure secure?</li> <li>• Are the power supply and ground wires securely fastened?</li> <li>• Are the signal wires separated from the power supply wires?</li> </ul>
---	---

PROBLEM	PROBABLE CAUSE	CORRECTION
System will not operate after normal start-up procedure.	E-Stop switch engaged	Pull out E-Stop switch.
	Batteries fully discharged	Check batteries to ensure a full charge. Replace with new batteries if necessary.
	No power to the receiver	Check the diagnostic LED on the receiver to be sure power is applied. Ensure that the system is properly grounded.
Transmitter is transmitting (Power LED flashing), but crane will not respond	E-Stop switch engaged	Pull out the E-Stop push button and activated switch on transmitter.
	Transmitter out of range	Take the transmitter back into the range of the receiver.
	Receiver power off	Turn on power to receiver.
	E-Stop failure in transmitter	Check E-Stop push button for damage. Check wiring to contact element for broken or disconnected wires. Repair or replace E-Stop push button or wiring.
Receiver will not respond to transmitter(No LED flashing)	E-Stop failure in transmitter	Replace E-Stop Switch
	Battery dead	Replace battery
All crane motions operate intermittently	Receiver antenna is loose, corroded or missing	Tighten, clean or replace antenna.
	External antenna (if used) has loose connection, poor grounding or interference	Tighten antenna and ground connection.
	Ground wiring is poor. Conductor is too small, or receiver is grounded to chassis.	Ground wiring must be connected to machine power source ground. Minimum diameter of conductor ground is 12 AWG.
Some crane motions operate intermittently	Crane motion wiring may be loose	Check wiring from receiver to plug and from plug to crane motion actuator.

# Transmitter Troubleshooting

Notice: When testing the transmitter, the receiver may become active resulting in system operation. Always assume the system is working and will respond when testing a transmitter.

## Status LED Troubleshooting

LED Indication	Possible Cause
LED is off	Transmitter is off
LED flashes	Transmitter is operating in a normal mode
LED will not light when any button is pushed, or LED remains on continuously	Replace batteries. Check for a faulty or worn E-Stop switch. If these do not correct the problem, the transmitter must be returned for repair.

## Transmitter Repairs

Notice: The transmitter electronic components are exposed when the back of the case is removed. Take caution to prevent dirt or other contaminants from entering the case. Do not allow the circuit to be scraped or damaged in any way.

# Receiver Troubleshooting

The following steps should be followed when troubleshooting the receiver.

1. Check the LED indicator. If it is not lit:
  - a. Make sure electrical and ground are present at the connecting wires.
  - b. If using the AC power, check for AC power on the connecting wires.
  - c. If input power is present and the LED is off, check for moisture damage.
  - d. If input power is present, the LED is off, and there is no moisture damage, the receiver may be faulty. Contact Customer Service at Stellar Industries.
2. Activate the transmitter by pressing any command switch.
  - a. If the receiver LED does not flash, test the transmitter.
  - b. Verify the identity code is the same for the transmitter and receiver. use the learn button to re-program the receiver for the transmitter.
  - c. Contact Customer Service at Stellar Industries.
3. Only some functions are operating:
  - a. Check to make sure the common wires for the relays are connected properly. (See Installation drawings for details.
  - b. Check output voltage of the respective wires and the electrical circuits.
  - c. Check the fuses inside the receiver case.
  - d. Check the receiver label to verify the function has been programmed to the needs of the equipment.
4. You are experiencing intermittent operation:
  - a. Check antenna connections and antenna location.
  - b. On AC systems, ensure noise suppression devices have been placed across the coils of all contacts.
  - c. Ensure you are inside the operating range of the receiver and have line of sight to the receiver antenna.
5. Operating Range is short:
  - a. Check all antenna connections and transmitter operation.
  - b. On new installations, verify the receiver antenna is placed properly. If necessary, use an antenna mounting kit to relocate the antenna to a more favorable location.

## Receiver Testing

LED Indication	Receiver Action
LED on continuous	Receiver operating voltage is present, no signal is being received.
LED flashes	Signal is being received that matches the decoders address.
LED goes off	Signal is being received, but address is wrong.



# Manual Operation

If the remote control malfunctions, follow these steps to operate the crane manually:

1. **Operate Solenoids/Winch Switch.** Press and hold the manual override switch and then push or pull to operate the desired function, as shown below:

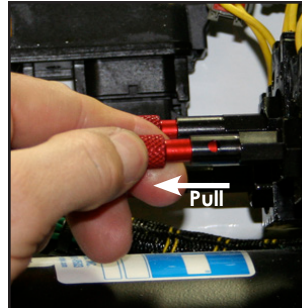

## Manual Override Pull Function

While pushing down the manual override switch (shown above), the knurled sleeve is pulled all the way out to manually override the pull solenoid function.

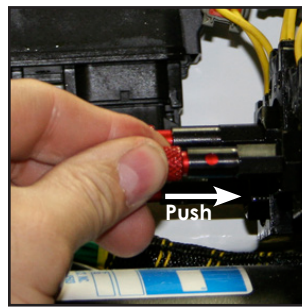

## Manual Override Push Function

While pushing down the manual override switch (shown above), the knurled sleeve should be pushed all the way in to override the push solenoid function.

To manually operate the winch, toggle the winch switch up and down as shown:

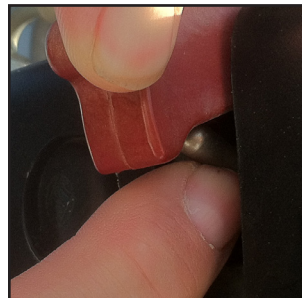
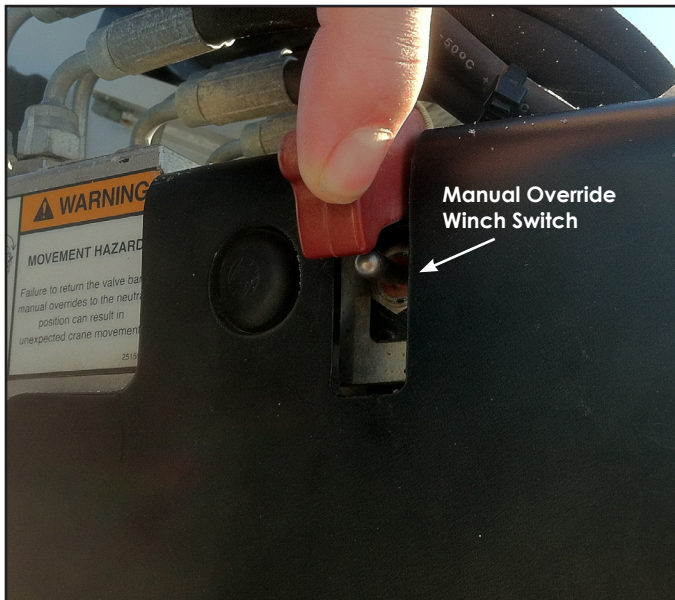

## Manual Winch Up

Push the manual winch switch up to raise the cable and hook.

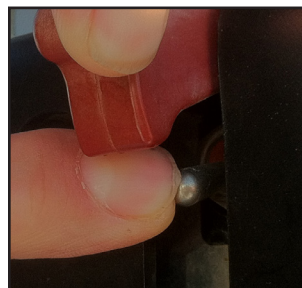

## Manual Winch Down:

Push the manual winch switch down to lower the cable and hook.

2. **Return the valve bank manual overrides to the neutral position.**

**WARNING** Failure to return the valve bank manual overrides to the neutral position can result in unexpected crane movement.

3. **Have unit serviced immediately to restore remote control functionality.**





Subject to Change without Notification.  
© 2016 Stellar Industries, Inc.