

Owner's Manual

Safety, Installation, Maintenance, and Operation

9628 Telescopic Crane

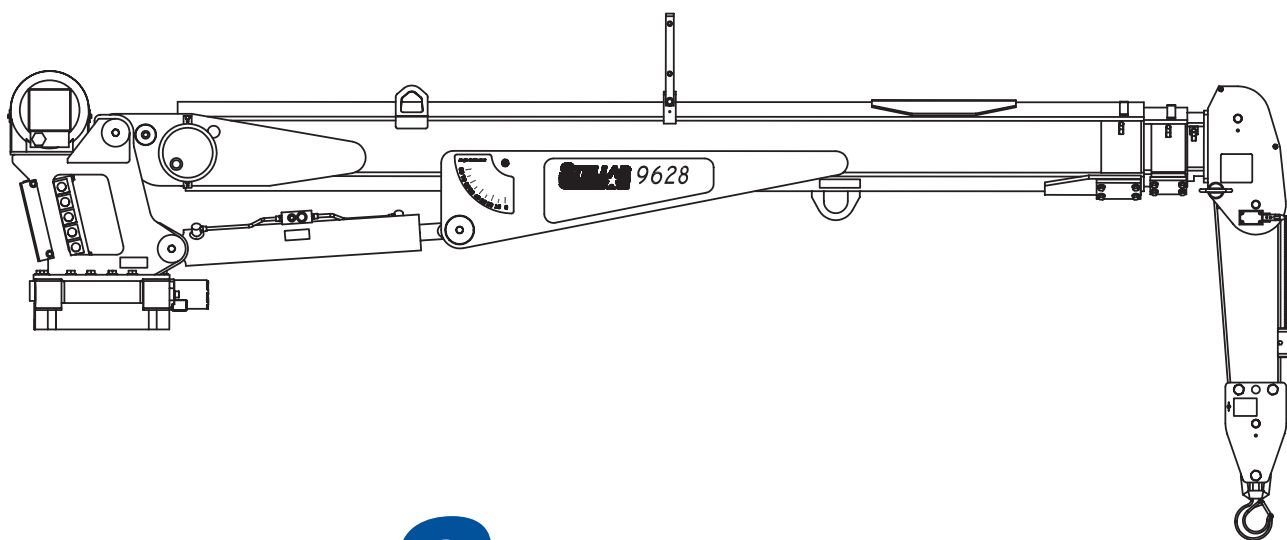

Stellar Industries, Inc.
190 State Street
PO Box 169
Garner, IA 50438
800-321-3741
Fax: 641-923-2811
www.stellarindustries.com

Introduction

Stellar cranes are designed to provide safe and dependable service for a variety of operations. With proper use and maintenance, Stellar cranes will operate at peak performance for many years.

This manual contains information vital to the safe use and efficient operation of this unit. Following the information provided within this manual can ensure the longevity of the crane. Carefully read and study the operator's manual before using the unit. Failure to adhere to the instructions could result in property damage or even serious bodily injury to the operator or others close to the crane.

A copy of this manual is provided with every crane and shall remain with the crane at all times. Information contained within this manual does not cover all maintenance, operating, or repair instructions pertinent to all possible situations. This manual is not binding. Stellar Industries, Inc. reserves the right to change, at any time, any or all of the items, components, and parts deemed necessary for product

improvement or commercial/production purposes. This right is kept with no requirement or obligation for immediate mandatory updating of this manual.

This product manual is not intended as a training manual for beginners or unskilled operators. This manual offers guidelines for correct and safe usage of the crane, maintenance, and troubleshooting. If more information is required or technical assistance is needed, please contact the Stellar Customer Service Department.

Some sections of this manual contain information pertaining to all Stellar manufactured cranes and may or may not apply to your specific model.

If this manual becomes damaged, misplaced, or unreadable at any point, or if you feel that any part of this manual is unclear or incorrect, please contact the Stellar Customer Service Department at 800-321-3741 or email at service@stellarindustries.com

**For Technical Questions, Information, Parts, or Warranty, Call Toll-Free at
800-321-3741**

Hours: Monday - Friday, 8:00 a.m. - 5:00 p.m. CST

Or email at the following addresses:

Technical Questions, and Information

service@stellarindustries.com

Order Parts

parts@stellarindustries.com

Warranty Information

warranty@stellarindustries.com

Table of Contents

Chapter 1 - Safety	1-1
Chapter 2 - Operation	2-1
Chapter 3 - Maintenance	3-1
Chapter 4 - Specifications	4-1
Chapter 5 - Decals	5-1
Chapter 6 - Installation	6-1
Chapter 7 - Assembly Drawings	7-1
Chapter 8 - Hydraulics/Electrical	8-1
Chapter 9 - Replacement Parts	9-1
Chapter 10 - Troubleshooting	10-1

Chapter 1 - Safety

Please Read the Following Carefully! This portion of the manual contains information regarding all Stellar manufactured cranes. Some items contained within this chapter may not apply to your specific equipment.

Safety should be the number one thought on every Stellar crane operator's mind. Three factors should exist for safe operation: a qualified operator, well-maintained equipment, and the proper use of this equipment. The following information should be read and understood completely by everyone working with or near the crane before beginning.

Stellar Industries, Inc. is not liable for accidents occurred during the usage of the crane caused by non-fulfillment from the operator's side of current rules, laws, and regulations.

GENERAL

It is the responsibility of the owner to instruct the operator in the safe operation of your equipment and to provide the operator with properly maintained equipment.

Trainees or untrained persons shall be under the direct supervision of qualified persons.

Do not operate equipment under the adverse influence of alcohol, drugs, or medication.

PERSONAL SAFETY

Keep clear of all moving parts.

Always wear the prescribed personal safety devices.

Always wear approved accident-prevention clothing such as: protective helmets, anti-slip shoes with steel toes, protective gloves, anti-noise headphones, protective glasses, and reflective jackets with breathing apparatus. Consult your employer regarding current safety

regulations and accident-prevention equipment.

Do not wear rings, wristwatch, jewelry, loose-fitting or hanging clothing such as ties, torn garments, scarves, unbuttoned jackets or unzipped overalls, which could get caught up in the moving parts of the crane.

Keep a first-aid box and a fire extinguisher readily available on the truck. Regularly check to make sure the fire extinguisher is fully charged and the first-aid kit is stocked.

Do not use controls and hoses as handholds. These parts move and cannot provide stable support.

Never allow anyone to ride the crane hook or load.

MAINTENANCE SAFETY

Never modify or alter any of the equipment, whether mechanical, electrical, or hydraulic, without Stellar Industries' approval.

Do not perform any maintenance or repair work on the crane unless authorized and trained to do so.

Release system pressure before attempting to make adjustments or repairs.

Do not attempt service or repair when PTO is engaged.

Failure to correctly plumb and wire the crane can cause a malfunction and damage to the crane and/or operator.

Decals are considered safety equipment. They must be maintained, as would other safety devices. Do not remove any decals. Replace any decals that are missing, damaged, or not legible.

The safety instruction plates, notices, load charts and any other sticker applied to the crane or service body must be kept legible and in good condition. If necessary, replace them.

STABILITY

Know the crane components and their capabilities and limitations. Overloading the crane may result in serious damage of self, others, equipment or the surroundings.

Never exceed manufacturer's load ratings. These ratings are based on the machine's hydraulic, mechanical, and structural design rather than stability.

The supporting surface under the service truck must be able to support the weight of the machine and its load. Use outrigger pads if necessary.

Park the vehicle on level ground and extend the outriggers fully out and then down.

Keep feet and legs clear when lowering outrigger jacks.

Never operate the crane without making sure the outriggers are positioned on stable, flat ground.

Set the parking break and disengage the drive axle before attempting a lift.

LOAD SAFETY

Operate the crane in compliance with the load capacity chart at all times. Know the weight of the load being lifted. Do not rely on the overload device to determine maximum rated loads.

Never use a sling bar or anything larger than the hook throat that could prevent the hook latch from closing, thus negating the safety feature.

Do not apply side loads to the booms.

Do not leave a crane load suspended or unattended.

Do not walk under suspended loads.

Do not position any load over a person nor should any person be permitted to place him or herself under a load.

Do not use the boom or the winch to drag a load. No crane is designed for these types of loads.

Do not use the crane boom to push downward onto anything.

ELECTROCUTION

Allow extra space for swaying power lines in windy conditions.

Keep a minimum of ten feet between any portion of the crane and an electrical line. Add an additional 12" for every additional 30,000 Volts or less.

Remember - Death or serious injury can occur when working near power lines or during electrical storms.

Use a signal person when operating near electrical sources.

ENVIRONMENT

Do not operate the crane during electrical storms.

In extreme cold, allow adequate time to warm the truck before engaging the PTO. Do not rev the truck engine and over speed the hydraulic pumps as permanent damage to the pumps may occur. Follow the vehicle owner's manual regarding operating the vehicle in such adverse conditions.

In dusty work areas, every effort must be taken to keep dust and sand out of the moving parts of the machinery.

In high humidity work areas, keep parts as dry as possible and well lubricated.

Chapter 2 - Operation

Job-Site Set-Up

Thoroughly plan the lift before positioning the vehicle. Consider the following:

1. The vehicle should be positioned in an area free from overhead obstructions to eliminate the need for repositioning.
2. Position the vehicle so that it is impossible for any portion of the equipment to come within the minimum required safe distance of any power line. Maintain a clearance of at least 10 feet between any part of the crane, load line, or load, and any electrical line or apparatus carrying up to 50,000 volts. One foot additional clearance is required for every additional 30,000 volts or less. Remember to allow for winds that cause power lines to sway. It is recommended that a signal person be used when the vehicle is set-up near power lines.
3. The vehicle should also be positioned on a firm and level surface that will provide adequate support for the outrigger loading. Use extreme caution when setting up near overhanging banks or excavations.
4. The parking break must be set on the vehicle and the drive axle disengaged before performing a crane operation.
5. The outriggers must be extended to stabilize the truck before beginning operation.

Unit Operation Overview

1. Engage the PTO
2. Turn on Power to Crane
3. Position Outriggers
4. Operate Crane
5. Store Outriggers
6. Turn Off Power to Crane
7. Disengage the PTO

1. Engage the PTO

- A. Engage the parking brake.
- B. Place the transmission in the Neutral position.
- C. Make certain the PTO switch is in the 'off' position.
- D. Start the vehicle engine.
- E. Depress the clutch on manual transmission vehicles.
- F. Engage the PTO switch for cable and air type shifters. Turn on dash switch for electrical operated style. Consult vehicle owner's manual for location and operation of OEM style in-dash PTO switch.
- G. Slowly release the clutch on a manual transmission vehicle.
- H. Warm engine and hydraulic system oil. Let system run for 10-20 minutes for warm-up. This is especially important in cold weather.
- I. Proceed with the outrigger and crane operation.



PTO Switch

2. Turn on Power to Crane

Activate power to the crane and outriggers. The power switch is located on the control panel in the vehicle cab.

3. Position Outriggers

Once the PTO is engaged, extend the outriggers using the control levers or switches marked 'outrigger'. These may be located on the crane base or in the compartment under the crane. See photo below.



Outrigger control panel, located in the crane compartment.

6 Function Remote

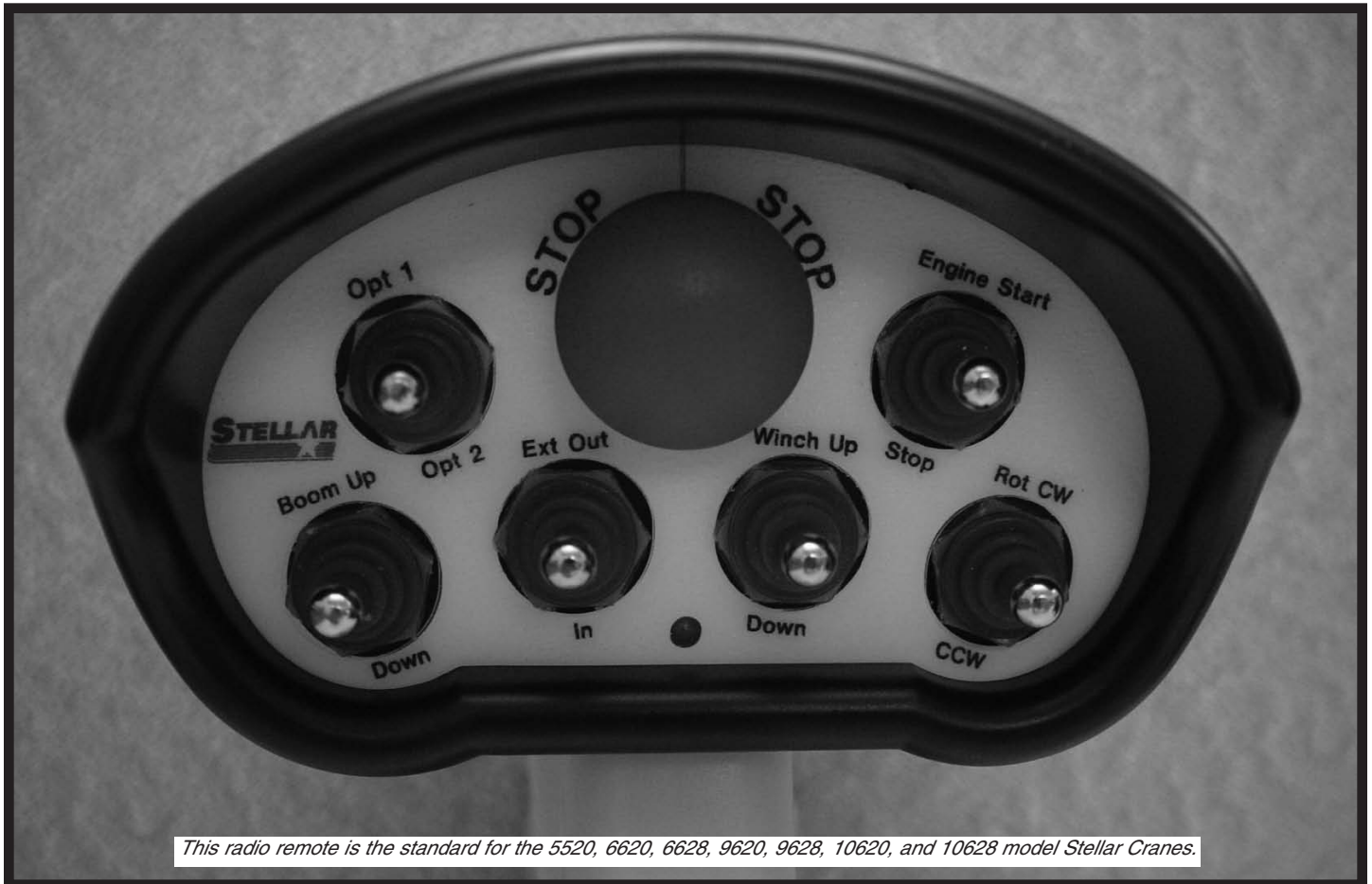

4. Operate Crane

- A. Turn on necessary power to the crane.
- B. Activate toggle switch for desired crane function. See Figures 1-a, 1-b, 1-c, 1-d.
- D. Activate the push button switch located off of the index finger to operate the function.
- E. When operation is complete, store remote handle in a safe, dry location.

5. Store Outriggers

- Retract outriggers using the control levers or switches marked 'outrigger'.
6. Turn Off Power to Crane
Deactivate power to crane and outriggers.
 7. Disengage the PTO
 - A. On manual transmission vehicles, depress the clutch pedal completely.
 - B. Disengage the PTO switch.
 - C. If vehicle is a manual transmission, release the clutch pedal gradually.

NOTE: The radio control is an electrical device. Please Handle With Care!

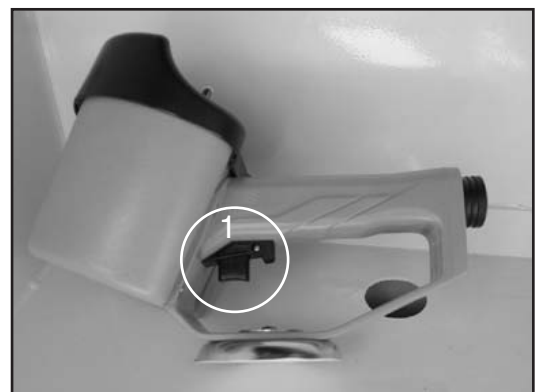

Variable Speed Trigger on remote.

The crane should not function until the trigger has been activated. The speed of the crane will vary in direct correlation with how much or how little the trigger is engaged.

4 Function Remote

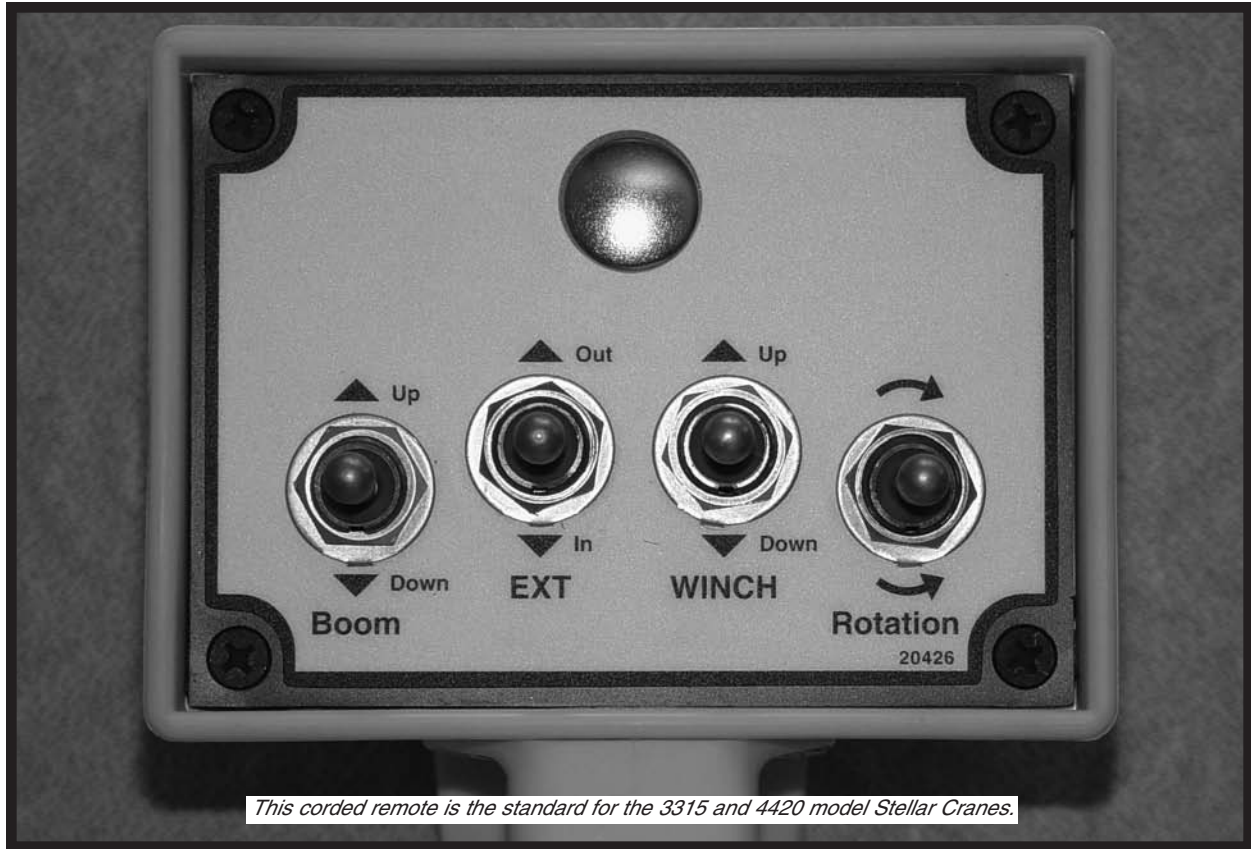

This corded remote is the standard for the 3315 and 4420 model Stellar Cranes.

6 Function Remote

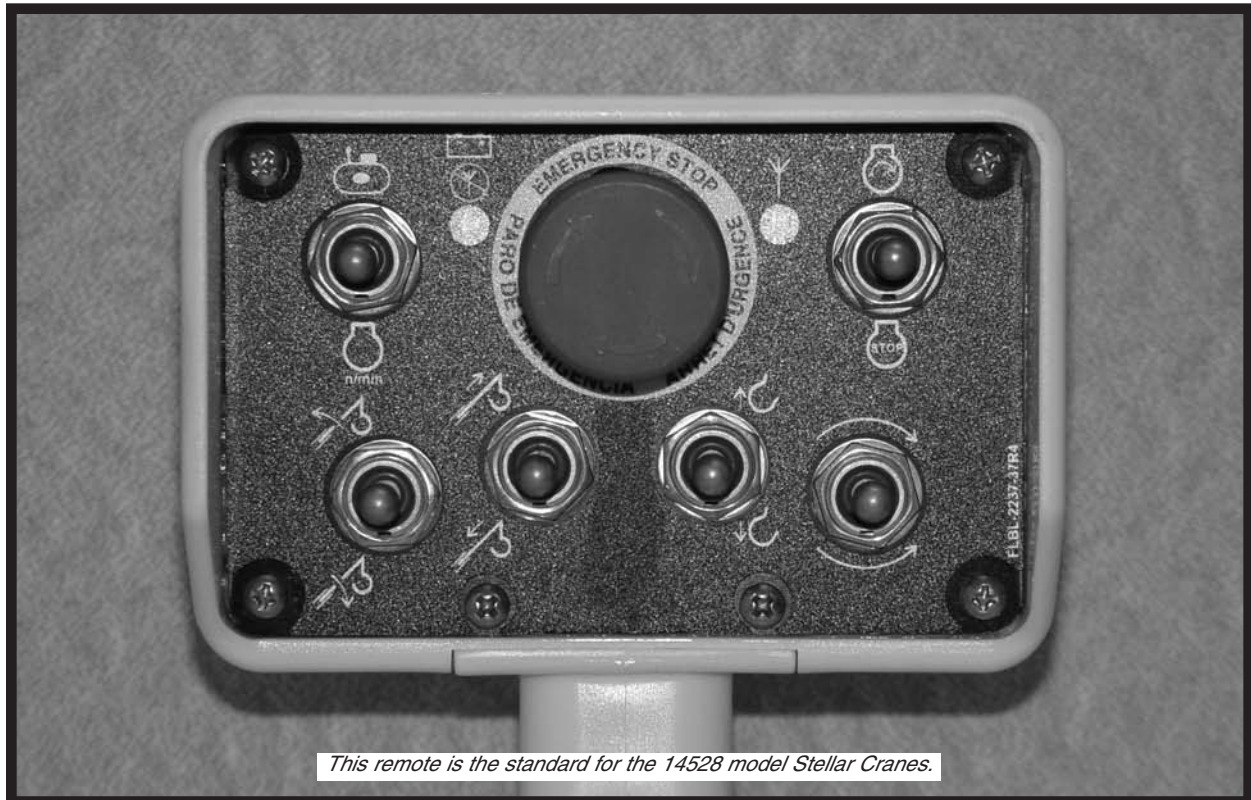

This remote is the standard for the 14528 model Stellar Cranes.

Manual Operation

If the remote control malfunctions, follow these steps to operate the crane manually:

- 1. Activate Flow Control.** Turn the override screw on flow control counter-clockwise. Full adjustment is between three and five turns.
- 2. Operate Solenoids.** Slide the knurled sleeve out and then push or pull to operate, as shown below. Be sure the sleeve is in the center, locked, position before returning to remote operation.
- 3. Deactivate flow control.** Turn the override screw clockwise until stopped. Full adjustment is between 3 and 5 turns.
- 4. Have unit serviced immediately to restore remote control functionality.**

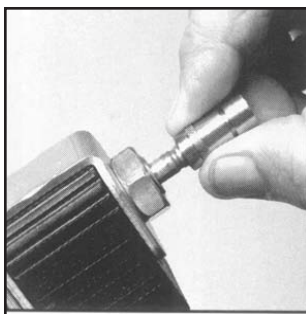
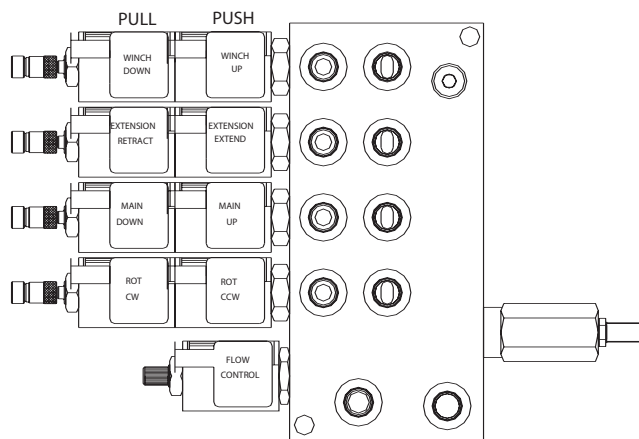

Manual Override Pull Function

The knurled sleeve is pulled all the way out together with the knob to manually override the pull solenoid function.

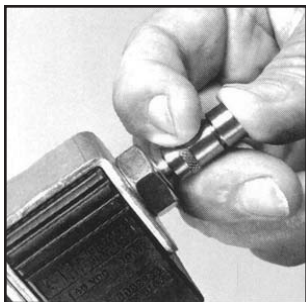

Manual Override Push Function

The knurled sleeve should first be pulled to unlatch the ball latching mechanism and then, while holding the sleeve back, the override knob should be pushed all the way in to override the push solenoid.

Crane Precautions

1. Movement of the control levers should be slow and smooth to meter oil flow for safe operation. Avoid jerky and sudden movements.
2. The crane controls should be clearly marked with decals. If these are missing or illegible, replace immediately. (See Chapter 5: Decals)
3. Lift load slightly off the ground to check the safety of the cargo. Do not use stability to determine the safety. Consult the capacity charts and strictly adhere to them.
4. Be constantly aware of the boom position when operating the controls.
5. The boom tip should be centered directly over the load before making the lift to avoid swinging.
6. Do not drag loads with the crane.
7. Do not attempt to lift fixed loads.
8. Do not load boom in a sideways direction.
9. Know the weight of the rigging and load to avoid overloading the crane.
10. Do not extend or rotate a load over anyone.
11. Wear protective gear such as hardhat, safety glasses, steel-toed boots, and gloves.

Hook Precautions

1. Hooks are designed and manufactured to lift specific loads. The specified rated load of a hook applies to loads held uniformly in direct tension and does not take into account shock loads, hook tip loading, side loading, bending, torsional, or related loads.
2. Do not attempt to lift a load that is larger than the load rating of the hook.
3. Never use a hook's yield point as an indicator of its capacity.
4. Do not use a hook to lift personnel.
5. Know the rated load of the hook in use.
6. Never weld attachments to a finished hook in field applications. This will alter and destroy the design properties of the hook material.
7. Keep fingers, hands, body, and loose clothing from between the hook and the load.
8. Avoid shock loading.
9. Inspect the hook regularly for excessive wear and maintain it in safe operating condition.

Operator Information

OPERATOR REQUIREMENTS

1. Operation is limited to the following people:

- A. Designated individual.
- B. Trainees under direct supervision of the designated individual.
- C. Test or maintenance individual.
- D. Crane Inspector.

2. Operators must meet the following physical qualifications:

- A. Vision of at least 20/30 Snellen in one eye and 20/50 in the other, with or without corrective lenses.
- B. Ability to distinguish colors if color differentiation is required.
- C. Adequate hearing, with or without a hearing aid.
- D. No physical or emotional defects that may create a hazard to the operator or others.
- E. Normal depth perception and coordination.

3. In addition to the physical qualifications, Operators must:

- A. Demonstrate the ability to understand all decals, the owner's manual, and any other information required for safe operation of the crane.
- B. Be able to demonstrate the ability to safely control the crane.
- C. Know all safety regulations.
- D. Be responsible for maintenance requirements.
- E. Understand and be fully capable of implementing all emergency procedures.
- F. Understand the operating procedures as outlined by this manual, Ansi B30.5, and Federal/State Laws.

OPERATOR CONDUCT

1. Operators will not engage in any operation that would cause them to divert attention away from the operation of the crane.
2. Operators are responsible for all operations under their direct control.
3. Operators will not leave a suspended load unattended.
4. Operators will be familiar with the equipment and the maintenance required for proper care.

HANDLING THE LOAD

1. Size of the load:

- A. Do not load the crane beyond the rated capacity.
- B. It is the responsibility of the operator to know the weight of the handled load.

2. Attaching the load:

- A. Attach the load to the hook by means of slings or other approved devices.
- B. Do not wrap the hoist rope around the load.

3. Moving the load:

- A. Make certain that the crane is level and properly blocked.
- B. Ensure that the load is secure and balanced within the sling before moving it.
- C. Be sure that the crane is stable before moving the load. Use stabilizer pads to ensure the proper distribution of weight.
- D. Do not drag the load sideways.
- E. Make sure the hook is brought over the load to minimize swinging.
- F. No suspended load should pass over a person.
- G. Avoid sudden starts and stops when moving a load.

Chapter 3 - Maintenance

WARNING - Read the Following before performing any maintenance on the crane.

1. Only authorized service personnel are to perform maintenance on the crane.
2. Disengage the PTO before any service or repair is performed.
3. Do not disconnect hydraulic hoses while there is still pressure in those components.
4. Before disconnecting hydraulic components, place the boom on the ground or have it supported, shut off the engine, release any air pressure on the hydraulic reservoir, and move pedals and control levers repeatedly through their operating positions to relieve all pressures.
5. Keep the crane and service body clean and free from grease build-up, oil and dirt to prevent slippery conditions.
6. Perform all safety and maintenance checks before each period of use.
7. Replace parts with Stellar Industries, Inc. approved parts only.
8. Immediately repair or have repaired any components found to be inadequate.

Maintenance Procedures

1. Position the crane where it will be out of the way of other operations or vehicles in the area.
2. Be sure boom is lowered to the ground or otherwise secured from dropping.
3. Place all controls in the off position and secure operating features from inadvertent motion.
4. Disconnect power source.
5. Relieve hydraulic oil pressure from all hydraulic circuits before loosening or removing hydraulic components.
6. Label or tag parts when disassembling.

Daily Inspection

Daily Inspection should occur each day before the crane is put into use. Each day, inspect the crane for all of the following:

1. Hydraulic oil level.
2. Loose parts or damage to structures or weld.
3. Cylinder movement due to leakage.
4. Hoses and gearboxes for evidence of oil leaks.
5. Controls, including hand throttle for malfunction or adjustment.
6. Truck hand brake operation.
7. All securing hardware such as cotter pins, snap rings, hairpins, and pin keepers for proper installation.
8. All safety covers for proper installation.
9. Cylinder holding valves for proper operation.
10. Wire rope for broken wires, extensive wear, distortion, and heat damage.

Periodic Inspection

Periodic Inspection should occur while the crane is in use. For the duration of the usage, inspect the crane for all of the following:

1. Loose bolts and fasteners.
2. All pins, bearings, shafts, and gears for wear, cracks, or distortion to include all pivots, outriggers, sheave pins, and bearings.
3. Hydraulic systems for proper operating pressure.
4. Main frame mount bolts.
5. Cylinders for:
 - A. Damaged rods.
 - B. Dented barrels.
 - C. Drift from oil leaking internally.
 - D. Leaks at rod seals or holding valves.
6. PTO drive line system for proper alignment, lubrication, and tightness.
7. Hydraulic hose and tubing for evidence of damage such as blistering, crushing, or abrasion.

Weekly Inspection

Weekly Inspection should occur at the beginning of every work week. Each week, inspect the crane for all of the following:

1. Lubrication of points required by lubrication chart. See chart at the end of this chapter.
2. Proper operation of load hook safety latch.
3. Presence of this owner's manual.

Monthly Inspection

Monthly Inspection should occur at the beginning of every work month. Each month, inspect the crane for all of the following:

1. Frame bolt tightness - turn barrel nuts and mounting bolts during the first month of operation on new machines and then quarterly thereafter.
2. Cylinders and valves for leaks.
3. Lubrication.
4. Load hook for cracks or having more than 15 percent normal throat opening or 10 degrees twist.
5. Structural members for bends, cracks, or broken members.
6. All welds for breaks and cracks.
7. All pins and keepers for proper installation.
8. All control, safety, and capacity placards for readability and secure attachment.
9. Inspect all electrical wires and connections for worn, cut, or deteriorated insulation and bare wire. Replace or repair wires as required.
10. Tightness of all boom wear, pad-retaining bolts.

Cleanliness

An important item in preserving the long life of the crane is keeping dirt, grime, and corrosive material out of the working parts. Thoroughly wash the crane periodically.

Service

The following general suggestions should be helpful in analyzing and servicing your crane. Using the following systematic approach should be helpful in finding and fixing problems:

1. Determine the problem.
2. List and record possible causes.
3. Devise checks.
4. Conduct checks in a logical order to determine the cause.
5. Consider the remaining service life of components against the cost of parts and labor necessary to replace them.
6. Make the necessary repair.
7. Recheck to ensure that nothing has been overlooked.
8. Functionally test the new part in its system.

Inspection Checklist

For a more detailed outline of scheduled inspection points, refer to the Stellar Inspection Checklist at the end of this chapter. This list is an excellent guide for the inspection tasks that will help maintain the quality of your Stellar product. Feel free to photocopy the checklist as needed.



Follow these guidelines to maintain the quality of your Stellar product.

Stellar Lubrication Recommendations :

Component	Location	Recommendation
Engine	Crankcase	Apply Manufacturer's Recommendations
Hydraulic System Below -5°F -5°F to 90°F Above 90°F	Reservoir	Petro-Canada Arctic MV 15 (ISO 22) Petro-Canada HYDREX 32 (ISO 32) Petro-Canada HYDREX 46 (ISO 46)
Open Gears	Hand	Precision XL3 Moly EP 2 (NLGI 2 grease with moly)
Bearings, grease (including turntable bearing inner race)	Gun	Precision XL EP 2 (NLGI 2)
Worm Drive Gearbox	Gearbox	Precision Synthetic EP 00 (NLGI 00)
Planetary Gearbox (including winch)	Gearbox	Traxon Synthetic 75W-90 (API GL-5)
Wear Pad Lubrication	Spray	Gearshield NC
Compressor Fluids		
Reciprocating Single Stage Reciprocating Double Stage	Crankcase Crankcase	Compro 100 (ISO 100) Compro 100 (ISO 100)
Screw -15°F to 86°F -23°F to 100°F 32°F to 113°F	Crankcase	Compro XL-S 32 (ISO 32) Compro XL-S 46 (ISO46) Compro XL-S 68 (ISO68)

Greasing the Crane

Lubricate all grease gun points with Extreme Pressure Grease - Stellar P/N: 22059.

Wire Rope Maintenance

Wire Rope Inspection Points

While inspection of the entire rope is required, attention should be directed to these critical points:

1. **Pick-up Points** for signs of wear due to stress from repeated lifts.
2. **End Attachments** for corrosion and broken wires at both ends of the rope.
3. **Drums** for signs of corrugation and wear that may lead to wire damage.
4. **Sheaves** to ensure that each sheave has the proper groove size and contour.
5. **Abuse Points** for heavy amounts of scuffing and scraping.

It is important to perform detailed inspections of all ropes associated with the crane. These inspections can be divided into two types:

1. Frequent Inspection

- A. All running ropes should be inspected once each working day. These visual observations will be concerned with discovering damage that may be an immediate hazard. The following concerns should be addressed:
 1. Distortion of the rope.
 2. General corrosion.
 3. Broken or cut strands.
- B. Use caution while inspecting sections of rapid deterioration.
- C. Use caution while inspecting boom hoist ropes. Proper inspection is critical but difficult.

2. Periodic Inspection

- A. Inspection frequency will be determined by a qualified person and will be based on such factors as expected rope life, environment conditions, capacity of typical lifts, rates of usage, and exposure to shock loads. Periodic inspection needs to be performed at least annually.
- B. Periodic inspections will be performed by a qualified individual and will cover the entire length of the rope.

Only the surface wires of the rope need to be inspected. This inspection will be concerned with discovering damage that may be an immediate hazard. The following concerns should be addressed:

1. Distortion of the rope.
 2. General corrosion.
 3. Broken or cut strands.
 4. Reduction of rope diameter.
 5. Corroded or broken wires at end connections.
 6. Corroded, cracked, bent, worn, or improperly applied end connections.
- C. Use caution when inspecting the following:
1. Sections in contact with saddles, equalizer sheaves, or other sheaves where rope travel is limited.
 2. Sections of the rope at or near ends with corroded or broken wires.

Wire Rope Replacement

Rope replacement guidelines are as follows:

1. Broken wires, including standing ropes with more than two broken wires in one lay or more than one broken wire at an end connection.
2. Wear of one-third the original diameter of the outside wires.
3. Distortion of the rope structure.
4. Evidence of heat damage.
5. Reductions from nominal diameters of more than 1/64 in. (0.4 mm) for diameters from 5/16 in. (19.0 mm) and 1/32 in. (0.8 mm) for diameters from 3/8 in. (9.5 mm) to and including 1/2 in. (13.0 mm).

Wire Rope Maintenance

Proper maintenance is key in ensuring a long lasting rope. These three tips will help:

1. Store the rope to prevent damage.
2. Avoid objects that may scrape, bend, or crush the wires of the rope.
3. Always keep the rope well-lubricated.

Holding Valve Inspection Procedure

The cylinders are equipped with holding valves that prevent sudden movement of the cylinder rods in the event of a hydraulic hose or hydraulic component failure. The valve is checked in the following manner:

1. Identify the cylinder in question.
2. Identify the holding valves and the cylinder direction in question.
 - a. Cylinder Extend.
 - b. Cylinder Retract.
3. Place the machine so that the cylinder will be located in the appropriate testing position.
4. Pick the load (Do not exceed capacity, rated or stability).
5. Disengage hydraulics.
6. Operate crane functions.
 - A. If the cylinder creeps (lowering the load), replace the holding valve.
 - B. If the cylinder does not creep (load stays suspended), the valve is operational.

Gear-Bearing Bolt Maintenance

Anytime a gear-bearing bolt is removed, it must be replaced with a new bolt of the identical grade and size. Once a bolt has been torqued to 75% of its proof load and then removed, the torque coefficient may no longer be the same as when the bolt was new thus giving indeterminate damp loads after torquing.

Warning!

Failure to replace gear-bearing bolts may result in bolt failure due to metal fatigue causing serious injury or even death.

Torque Data Chart

Grade 5

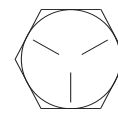

Grade 8

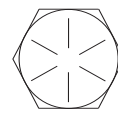

Grade 9

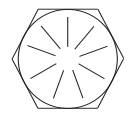

Size (DIA-TPI)	Bolt DIA (Inches)	Plain (Ft-Lb)	Plated (Ft-Lb)	Plain (Ft-Lb)	Plated (Ft-Lb)	Plated (Ft-Lb)
5/16-18	0.3125	17	13	25	18	22
3/8-16	0.3750	31	23	44	33	39
7/16-14	0.4375	49	37	70	52	63
1/2-13	0.5000	75	57	105	80	96
9/16-12	0.5625	110	82	155	115	139
5/8-11	0.6250	150	115	220	160	192
3/4-10	0.7500	265	200	375	280	340
7/8-9	0.8750	395	295	605	455	549
1-8	1.000	590	445	910	680	823
1 1/8-7	1.1250	795	595	1290	965	1167
1 1/4-7	1.2500	1120	840	1815	1360	1646
1 3/8-6	1.3750	1470	110	2380	1780	2158
1 1/2-6	1.500	1950	1460	3160	2370	2865

When using the torque data in the charts above, the following rules should be observed.

1. Bolt manufacturer's particular specifications should be consulted when provided.
2. Flat washers of equal strength must be used.
3. All torque measurements are given in foot-pounds. To convert to inch-pounds, multiply by 12.
4. Torque values specified are for bolts with residual oils or no special lubricants applied. If special lubricants of high stress ability, such as Never-Seez compound graphite and oil, molybdenum disulphite, colloidal copper or white lead are applied, multiply the torque values in the charts by the factor .90. The use of Loctite does not affect the torque values listed above.
5. Torque values for socket-head capscrews are the same as for Grade 8 capscrews.

Stellar Industries Inspection Checklist for Telescopic Boom Cranes

Use of this checklist is subject to terms of the Stellar Warranty information. Additional copies of this checklist can be obtained by contacting Stellar Customer Service at (800) 321-3741 or by download at: <http://www.stellarindustries.com/pages/downloads.htm>

Type of Inspection (check one)

- Daily (if deficiency found) Quarterly
 Monthly Annual

Owner/Company:

Contact Person:

Crane Make/Model:

Crane Serial:

Date Inspected:

Hour Meter Reading:

Inspected by: (print)

Signature of Inspector:

Type of Inspection Information

Daily and monthly inspections are to be performed by a “designated” person, who has been selected by the employer or the employer’s representative as being competent to perform specific duties.

Quarterly and annual inspections are to be performed by a “qualified” person who, by possession of a recognized degree in an applicable field or certificate of professional standing, or who, by extensive knowledge, training and experience has successfully demonstrated the ability to solve or resolve problems related to the subject matter and work.

One hour of normal crane operation assumes 20 complete cycles per hour. If operation exceeds 20 cycles per hour, inspection frequency should be increased accordingly.

Consult the Stellar Owner’s Manual for additional inspection items.

Before inspecting and operating the crane, make certain that the crane is set up away from power lines and leveled with outriggers fully extended.

Daily (D): Before each day of operation, those items with a (D) must be inspected. This inspection need not be recorded unless a deficiency is found.

Monthly (M): Monthly inspections or 100 hours of normal operation (which ever comes first) includes all daily and monthly inspection items plus items designated with a (Q). This inspection must be recorded.

Quarterly (Q): Every three months or 300 hours of normal operation (which ever comes first) includes all daily and monthly inspection items plus items designated with an (M). This inspection must be recorded.

Annual (A): Each year or 1200 hours of normal operation (which ever comes first) includes all items on this form which encompasses daily, monthly, and quarterly inspections plus those items designated by (A). this inspection must be recorded.

Monthly Inspection

Frequency	Key	Inspection Description	Status
M	Daily	All Daily Inspections.	
M	Cylinders	Visual inspection of cylinders for leakage at rod, fittings, & welds. Damage to rod & case.	
M	Valves	Holding valves for proper operation.	
M	Valves	Control valve for leaks at fittings & between sections.	
M	Valves	Control valve linkages for wear, smoothness of operation & tightness of fasteners. Relief valve for proper pressure settings.	
M	General	Bent, broken or significantly rusted/corroded parts.	
M	Electrical	Electrical systems for presence of dirt, moisture & frayed wires.	
M	Structure	All structural members for damage.	
M	Welds	All welds for breaks & cracks.	
M	Pins	All pins for proper installation & condition.	
M	Hardware	All bolts, fasteners & retaining rings for tightness, wear & corrosion.	
M	Wear Pads	Condition of wear pads.	
M	Pump & Motor	Hydraulic pumps & motors for leakage at fittings, seals & between sections. Check tightness of mounting bolts.	
M	PTO	Transmission/PTO for leakage, abnormal vibration & noise, alignment & mounting bolt torque.	
M	Hyd Fluid	Quality of hydraulic fluid and for presence of water.	
M	Hyd Lines	Hoses & tubes for leakage, abrasion damage, blistering, cracking, deterioration, fitting leakage, & secured properly.	
M	Hook	Load hook for abnormal throat distance, twist, wear, & cracks.	
M	Rope	Condition of load line.	
M	Manual	Presence of operator's manuals with the unit.	
M	Chassis	Tire wear and air pressure.	
M	Chassis	Working backup alarm.	
M	Station	Fire extinguisher at cab or machinery housing.	

Quarterly Inspection

Frequency	Key	Inspection Description	Status
Q	Daily	All daily inspections.	
Q	Monthly	All monthly inspections.	
Q	Rotation Sys	Rotation bearing for proper torque of all mounting bolts.	
Q	Hardware	Base mounting bolts for proper torque.	
Q	Structure	All structural members for deformation, cracks, & corrosion.	
		Base	
		Outrigger beams & legs	
		Mast	
		Inner boom	
		Outer boom	
		Extension(s)	
		Jib boom	
		Jib extension(s)	
		Other	
		Other	
Q	Hardware	Pins, bearings, shafts, gears, rollers, & locking devices for wear, cracks, corrosion, & distortion.	
		Inner boom pivot pin(s) & retainer(s)	
		Outer boom pivot pin(s) & retainer(s)	
		Inner boom cylinder pin(s) & retainer(s)	
		Outer boom cylinder pin(s) & retainer(s)	
		Extension cylinder pin(s) & retainer(s)	
		Jib boom pin(s) & retainer(s)	
		Jib cylinder pin(s) & retainer(s)	
		Jib extension cylinder pin(s) & retainer(s)	
		Boom tip attachments	
		Other	
		Other	

Quarterly Inspection Continued...

Frequency	Key	Inspection Description	Status
Q	Hyd Lines	Hoses, fittings, & tubing for proper routing, leakage, blistering, deformation, & excessive abrasion.	
		Pressure line(s) from pump to control valve	
		Return line(s) from control valve to reservoir	
		Suction line(s) from reservoir to pump	
		Pressure line(s) from control valve to each function	
		Load holding valve pipe(s) and hose(s)	
		Other	
Q	Pumps&Motors	Pumps and motors for loose bolts/fasteners, leaks, noise, vibration, loss of performance, heating and excess pressure.	
		Winch motor(s)	
		Rotation motor(s)	
		Other	
Q	Valves	Hydraulic valves for cracks, spool return to neutral, sticking spools, relief valve failure.	
		Main control valve	
		Load holding valve(s)	
		Outrigger or auxiliary control valve(s)	
		Other	
Q	Cylinders	Hydraulic cylinders for drifting & leakage. Rods for nicks, scores, & dents. Castor damage. Case & rod ends for damage & abnormal wear.	
		Outrigger cylinder(s)	
		Inner boom cylinder(s)	
		Outer boom cylinder(s)	
		Extension cylinder(s)	
		Rotation cylinder(s)	
		Jib lift cylinder(s)	
		Jib extension cylinder(s)	
		Other	
Q	Winch	Winch, sheaves, & drums for damage, abnormal wear, abrasion, & other irregularities.	
Q	Hyd Filter	Hydraulic filters for replacement per maintenance schedule.	

Chapter 4 - Specifications

Model 9628 Crane SPECIFICATION SHEET

Crane Rating:	55,000 ft-lbs (7.6 ton-meters)
Standard Boom Length:	12' 4" (3.28 m) from CL of Crane
Boom Extension:	1st stage: Hydraulic 96" (244 cm) 2nd stage: Hydraulic 96" (244 cm)
Maximum Horizontal Reach:	28' 4" (8.64 m) from CL of Crane
Maximum Vertical Lift: (from crane base)	29' 4" (8.94 m)
Boom Elevation:	-5 to +80 degrees
Stowed Height: (crane only)	34 inches (86.4 cm)
Mounting Space Required:	20" x 21" (50.8 x 53.3 cm)
Approximate Shipping Weight:	2850 lbs (1295 kg)
Controls:	Radio control standard for all functions.
Winch Specifications	
Rope Diameter:	3/8" (.953 cm)
Line pull speed:	60 ft/min (18.29 m/min)
Max. single part line:	4300 lbs (1950 kg)
Max. double part line:	8600 lbs (3900 kg)
Rotation: (worm gear)	400 degree power
Lifting Capacities:	4450 lbs @ 12' 4" (2020 kg @ 3.28 m) 1925 lbs @ 28' 4" (875 kg @ 8.64 m)
Power Supply Required:	PTO & Pump (8 gpm @ 3000 psi) (30.3 lpm @ 207 bars)

*Subject to change without notification

CAPACITY CHART

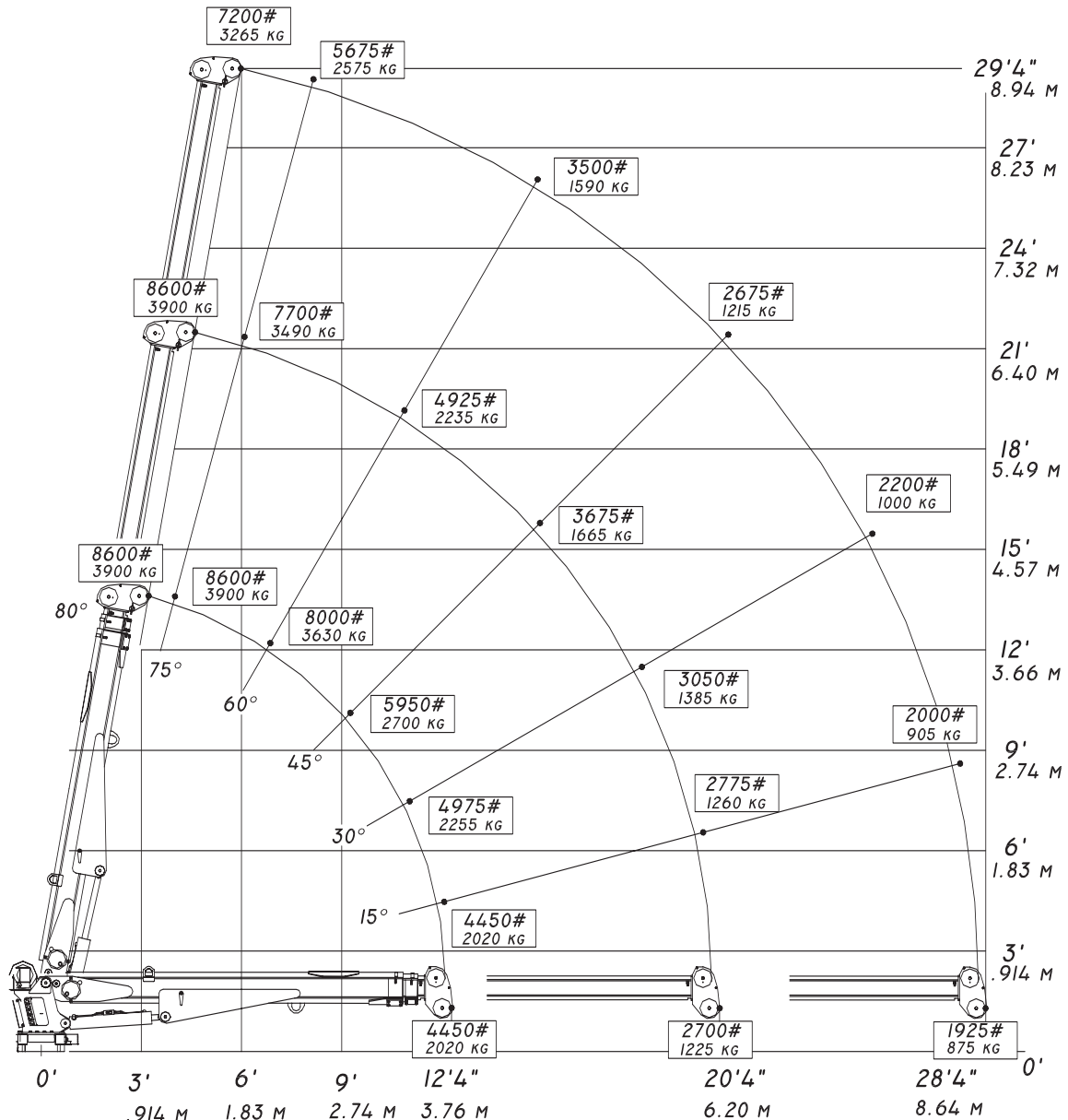

Maximum 1-part line capacity is 4300 lbs (1950 kg).
For greater loads, use 2-part line.

Weight of load handling devices are part of the load lifted and must be deducted from the capacity.

REACH IN FEET/METERS
CAPACITY IN POUNDS/KILOGRAMS

STELLAR 9628

23513

Chapter 5 - Decals

Decals of Note



Foot Crushing Hazard Decal

Location: On each outrigger leg.

Function: To inform the operator and other personnel in the work area of the hazard associated with the operation of the outriggers, the possible consequences should the hazard occur, and how to avoid the hazard. PN: C4795

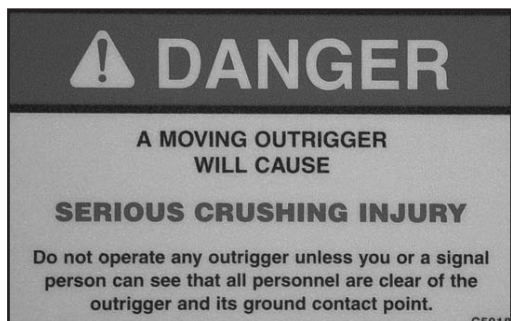

Moving Outrigger Hazard Decal

Location: On each outrigger

Function: To inform the operator of the hazard associated with outrigger operation, the possible consequences should the hazard occur, and how to avoid the hazard. PN: C5918



Instructional Decal

Location: At Stow Hook area

Function: To caution the operator not to use the stow hook for any lifting applications. PN: 24712

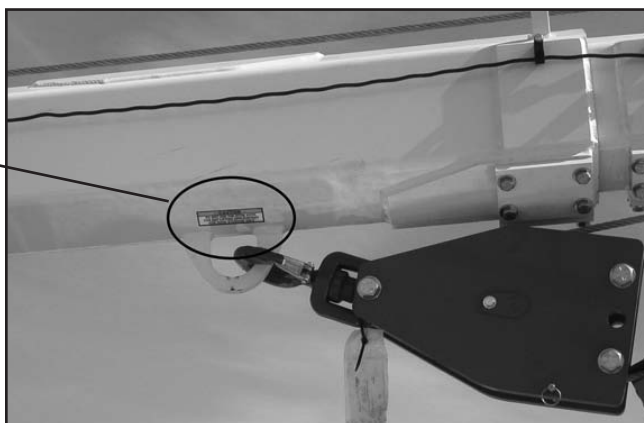



Electrocution Hazard Decal
Location: Each side of truck body, Front & Rear Bumper
Function: To inform the operator and other personnel in the work area of the hazard associated with contact or proximity to electrical lines, the possible consequences should the hazard occur and how to avoid the hazard.
 PN: C4545

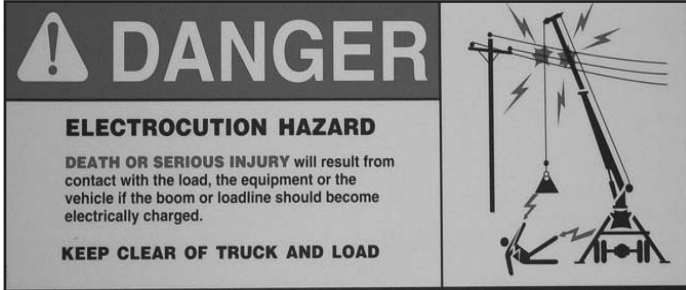

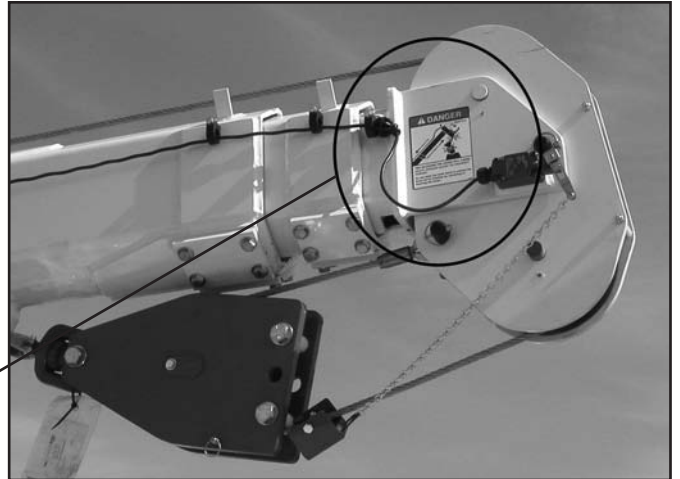
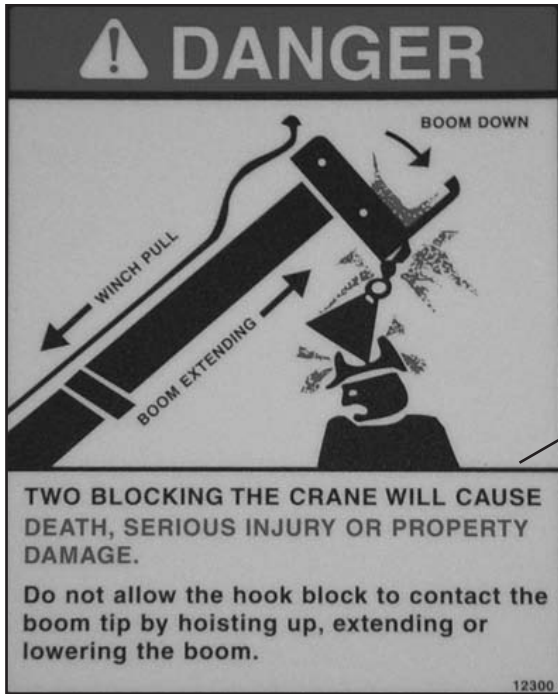

Two Block Hazard Decal

Location: At Boom Tip

Function: To inform the operator of the hazard associated with bringing the sheave(s) into contact with the hook, snatch block or load, the possible consequences should the hazard occur and how to avoid the hazard. PN: 12300

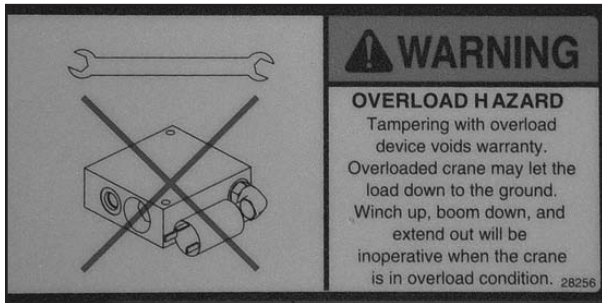

Instructional Decal

Location: At Overload Switch

Function: To inform the operator that tampering with the overload device may cause a unit failure.

PN: 28256





Free Falling Manual Boom Decal

Location: Inside Crane Compartment, on Compartment Door

Function: To inform the operator of the hazard associated with free falling manual boom extensions, the possible consequences should the hazard occur, and how to avoid the hazard.
PN: 12452

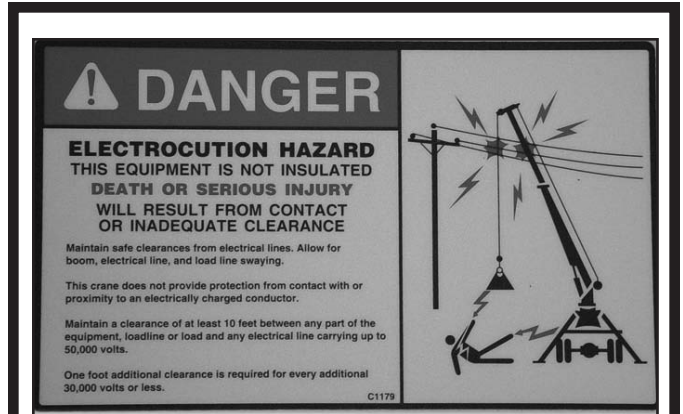

Electrocution Hazard Decal

Location: Inside Crane Compartment, on Compartment Door

Function: To inform the operator of the hazard associated with overloading the crane, the possible consequences should the hazard occur, and how to avoid the hazard.
PN: C1179

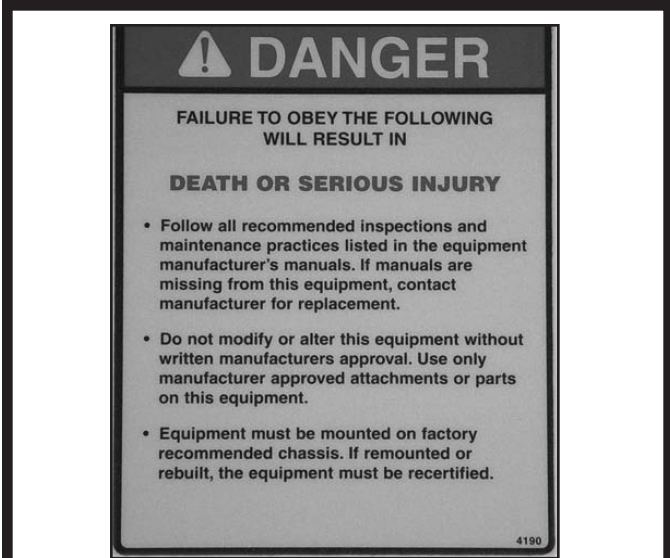

Operation Hazard Decal

Location: Inside Crane Compartment, on Compartment Door

Function: To inform the operator and other personnel in the work area of the hazard associated with improper maintenance and unauthorized modifications, the possible consequences should the hazard occur, and how to avoid the hazard.
PN: 4190

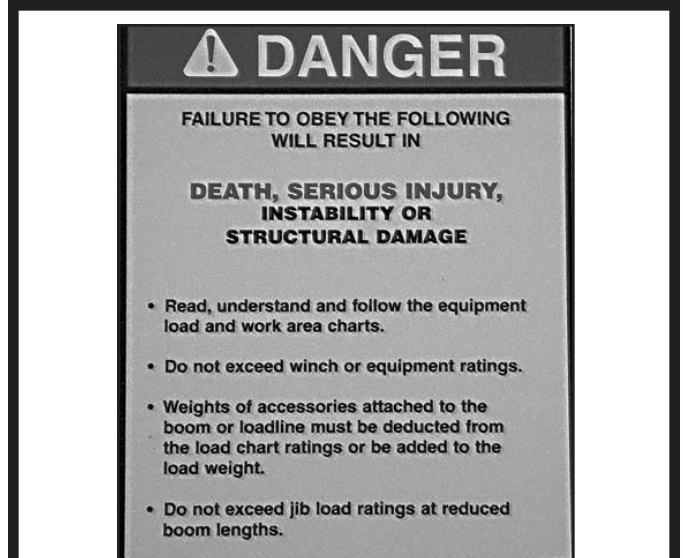

Operation Hazard Decal

Location: Inside Crane Compartment, on Compartment Door

Function: To inform the operator of the hazard associated with overloading the crane, the possible consequences should the hazard occur, and how to avoid the hazard.
PN: 4189

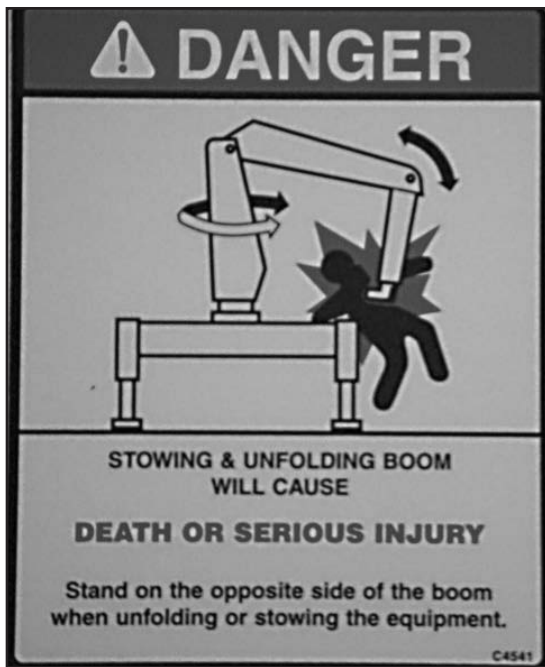

Moving Boom Hazard Decal

Location: Inside Crane Compartment, on Compartment Door

Function: To inform the operator and other personnel in the work area of the hazard associated with a moving boom, especially while stowing and unfolding the crane, the possible consequences should the hazard occur, and how to avoid the hazard.

PN: C4541

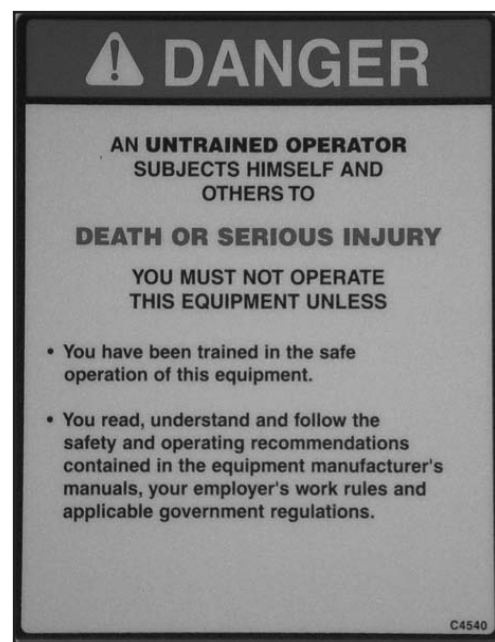

Operation Hazard Decal

Location: Inside Crane Compartment, on Compartment Door

Function: To inform the operator of the need for proper training, familiarity with safe operating procedures and, the possible consequences without training.

PN: C4540

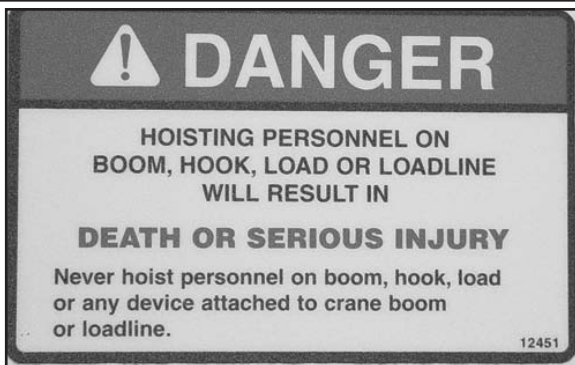

Hoisting Decal:

Location: Inside Crane Compartment, on Compartment Door

Function: To inform the operator of the hazard associated with lifting personnel with the boom, boom hook, the load or winch loadline, the possible consequences of lifting personnel, and how to avoid the hazard. PN: 12451

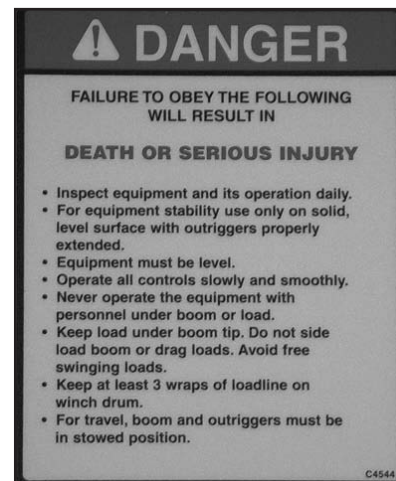

Training Decal:

Location: Inside Crane Compartment, on Compartment Door

Function: To inform the operator of the need for proper training, familiarity with safe operating procedures, and the possible consequences of operation without training. PN: C4544

Decal Placement

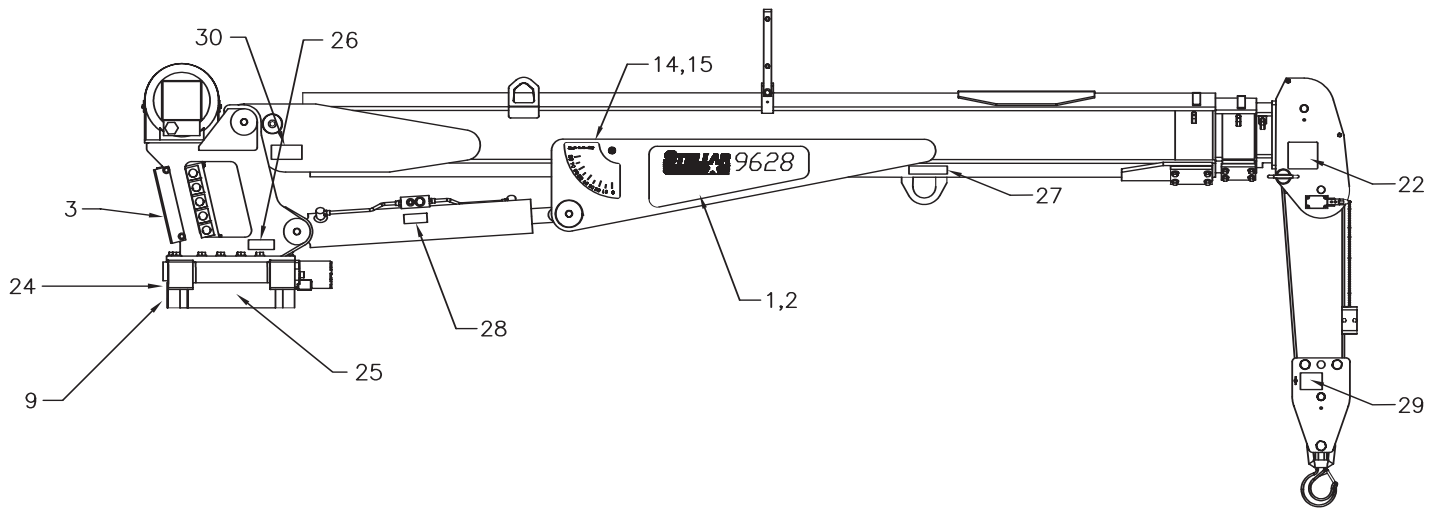

*USE THESE DECALS WITH BODY PACKAGE

15	D1197	DECAL-ANGLE INDICATOR SS	1	**30	35234	DECAL STELLAR MADE IN THE USA	1
14	D1196	DECAL ANGLE INDICATOR CS	1	29	34225	DECAL SNATCH BLOCK CAP 5 TON	1
*13	C1179	DECAL-ELECTROCUTION 4.5x7.5	2	28	28256	DECAL WARNING OVERLOAD DEVICE	1
*12	C5918	DECAL-DANGER MOVING O.R.	2	27	24712	DECAL CAUTION STOW HOOK	1
*11	C4795	DECAL-DANGER O.R.	2	26	15172	DECAL ASME/ANSI B30.22/B30.5	1
*10	4190	DECAL-DANGER	1	25	15171	DECAL GREASE WORM DRIVE BEARINGS	1
09	9188	DECAL-ROTATE/GREASE	1	24	4188	DECAL-ROTATION ALIGNMENT	1
*08	4189	DECAL-DANGER	1	*23	C4541	DECAL-CRANE STOWING	1
07	4186	DECAL-ELECTROCUTION 2x2.75	1	22	12300	DECAL-TWO BLOCKING	1
*06	C4544	DECAL-DANGER	1	*21	4214	DECAL-SERVICE	1
*05	C4540	DECAL-DANGER	1	*20	C0568	DECAL-DIESEL	2
*04	C4545	DECAL-ELECTROCUTION 5x13	4	*19	12452	DECAL MANUAL EXT	1
*03	23513	DECAL CAPACITY	2	*18	C5911	DECAL-STELLAR 2x4.5	3
02	23512	DECAL IDENTIFICATION SS	1	*17	C5910	DECAL-STELLAR 4x9.5	1
01	23511	DECAL IDENTIFICATION CS	1	*16	12451	DECAL HOISTING PERSONNEL	1
ITEM	PART No.	DESCRIPTION	QTY	ITEM	PART No.	DESCRIPTION	QTY

Chapter 7 - Assembly Drawings

Base Assembly

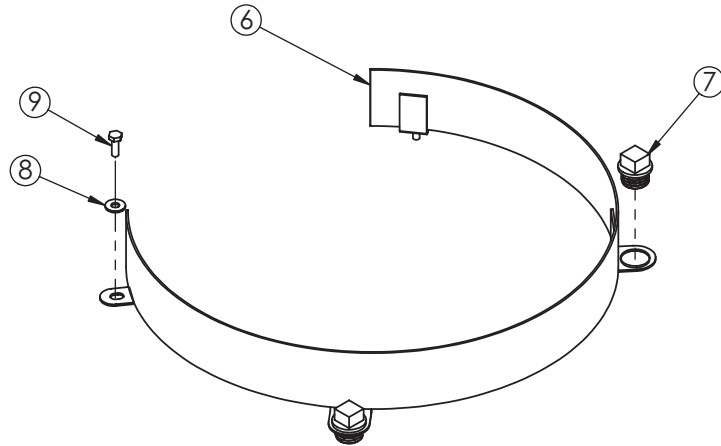

GASKET SHOWN AS REFERENCE

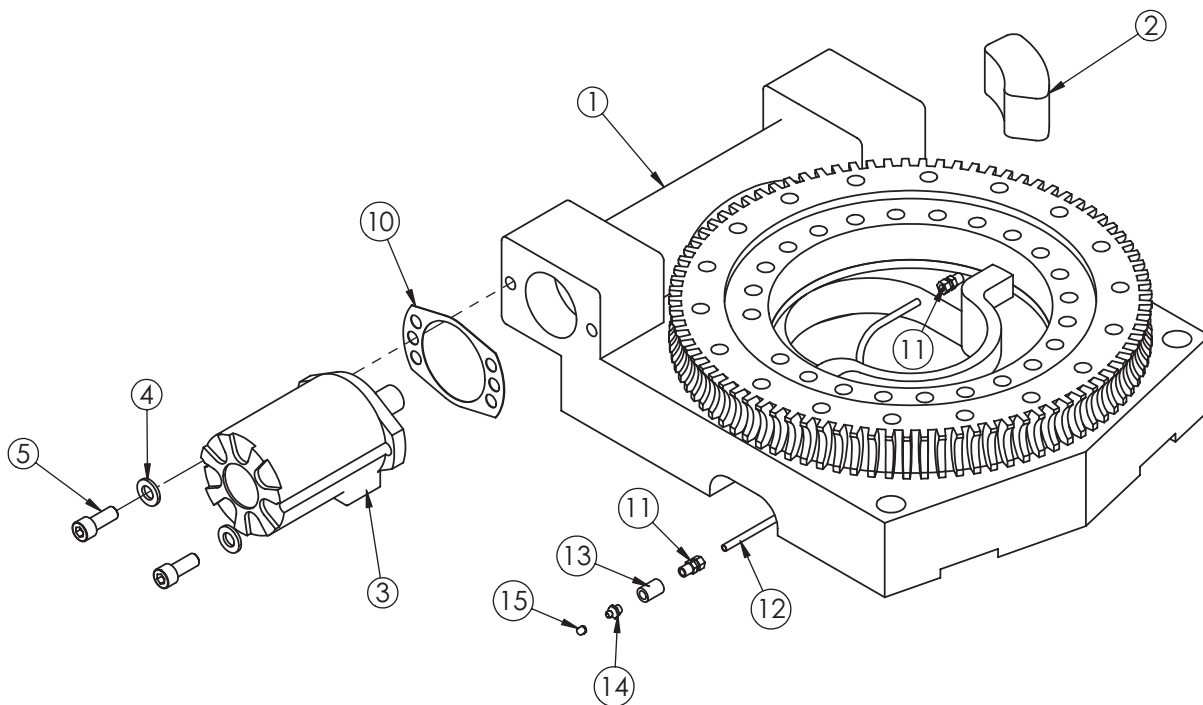

P/N 18027

ITEM	PART	DESCRIPTION	QTY.
1	11453	BEARING SWING DRIVE CAST BASE 6620	1
2	11542	STOP 3820 400 SLIDE	1
3	C6069	MOTOR HYD ROSS MK080613AAAB	1
4	D0790	WASHER 0.50 FLAT GR8	2
5	D1307	CAP SCR 0.50-13X1.25 SH	2
6	12730	GUARD TTB 6620 CRANE	1
7	13959	CAP SCR 1.00-8 X .63 PLASTIC	2
8	0340	WASHER 0.25 FLAT	2
9	0479	CAP SCR 0.25-20X0.75 HHGR5	2
10	21151	GASKET MOTOR 008-10056-1	1
11	D1345	FTG CPRSN 0.12NPT/0.25 TUBE	2
12	D1810	TBE AIR SAEJ844 TYPE A .25 (28")	1
13	C2256	FTG COUPLER PIPE 0.13	1
14	c1592	ZERK 1/8 NPT STRAIGHT	1
15	C4808	CAP PLASTIC (RED)	1

Mast Assembly

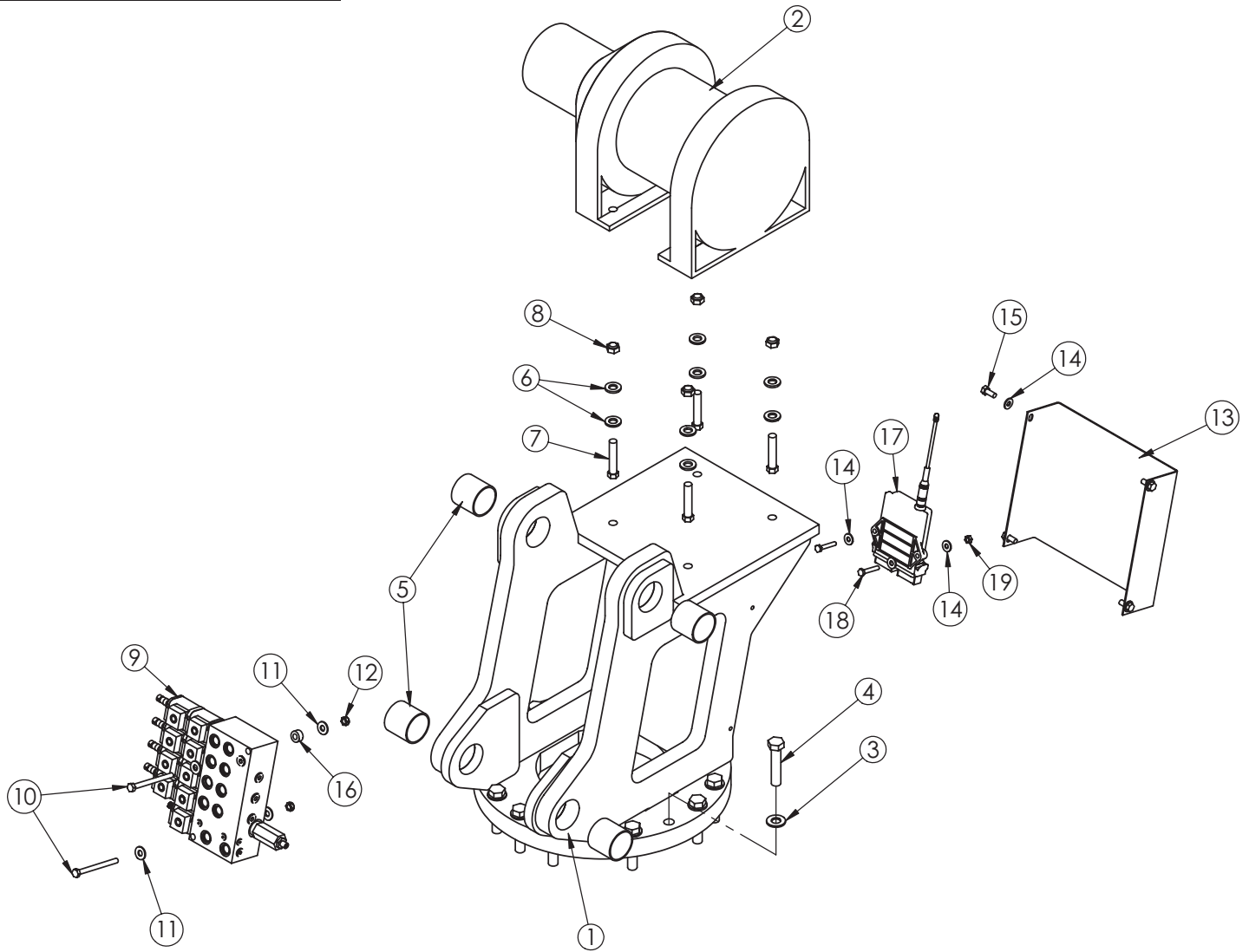

P/N 18028

ITEM	PART	DESCRIPTION	QTY.
1	12967	MAST 9620 CRANE	1
2	12968	WINCH 5000	1
3	C5902	WASHER 0.63 SAE FLAT YELLOW GR8	14
4	D1034	CAP SCR 0.63-11 X 3.00 HHGR8 ZY	14
5	4381	BUSHING 32DXR32 2.00X2.00 GARLOCK	4
6	D0790	WASHER 0.50 FLAT GR8	8
7	10662	CAP SCR 0.50-13X2.50 HHGR8 ZY	4
8	C6106	NUT 0.50-13 HHGR5 NYLOC	4
9	24685	VB 4 SECT ELECT W/PROP STERLING8GPM	1
10	24139	CAP SCR 0.31-18X3.75 HHGR5	2
11	0343	WASHER 0.31 USS FLAT ZINC	4
12	0342	NUT 0.31-18 HH NYLOC	2
13	13391	COVER 9620 MAST	1
14	0340	WASHER 0.25 FLAT	8
15	0420	CAP SCR 0.31-18X0.75 HHGR5	4
16	27813	COLLAR 0.38X0.75X0.38 UHMW	2
17	34103	RECEIVER RADIO CONTROL 6 FCTN H2	1
18	0220	CAP SCR 0.25-20 X 1.50 HHGR5	2
19	0333	NUT 0.25-20 HHGR5 NYLOC	2

Mast Assembly - 2 Speed Winch Version

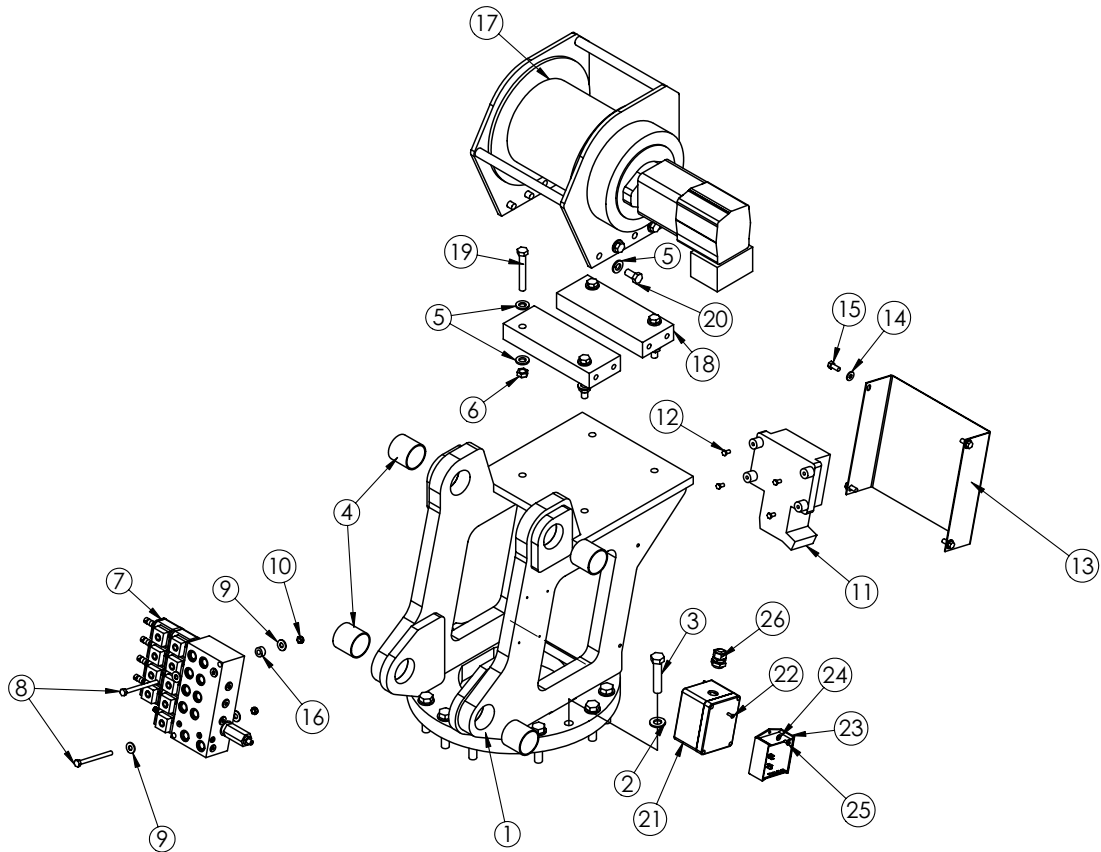

PN 27840

ITEM	PART	DESCRIPTION	QTY.
1	27971	MAST 9628 2-SPEED	1
2	C5902	WASHER 0.63 SAE FLAT YELLOW GR8	14
3	D1034	CAP SCR 0.63-11 X 3.00 HHGR8 ZY	14
4	4381	BUSHING 32DXR32 2.00X2.00 GARLOCK	4
5	D0790	WASHER 0.50 FLAT GR8	16
6	C6106	NUT 0.50-13 HHGR5 NYLOC	4
7	24685	VB 4 SECT ELECT W/PROP STERLING8GPM	1
8	24139	CAP SCR 0.31-18X3.75 HHGR5	2
9	0343	WASHER 0.31 USS FLAT ZINC	4
10	0342	NUT 0.31-18 HH NYLOC	2
11	11847	RADIO RECEIVER	1
12	10976	CAP SCR 6MMX12MM HHGR8	4
13	13391	COVER 9620 MAST	1
14	0340	WASHER 0.25 FLAT	4
15	0420	CAP SCR 0.31-18X0.75 HHGR5	4
16	27813	COLLAR 0.38X0.75X0.38 UHMW	2
17	27165P	WINCH 5000 505W 2 SPEED	1
18	27841	FLAT WINCH MTG 9628 2 SPEED	2
19	30750	CAP SCR 0.50-13X3.50 HHGR8	4
20	10172	CAP SCR 0.50-13X1.00 HHGR8 ZY	8
21	27970	ENCLOSURE 9628 2 SPEED	1
22	27973	CAP SCR #8-32X0.50 BTNHD	4
23	14066	RELAY LATCHING MODULE TSD LRM02	1
24	5290	WASHER #8 SAE FLAT ZP	2
25	8649	SCREW #8X0.38 SHEET MTL PHIL PH	2
26	12869	STRAIN RELIEF .50 NPT .24-.47 CABLE	1

Main Boom

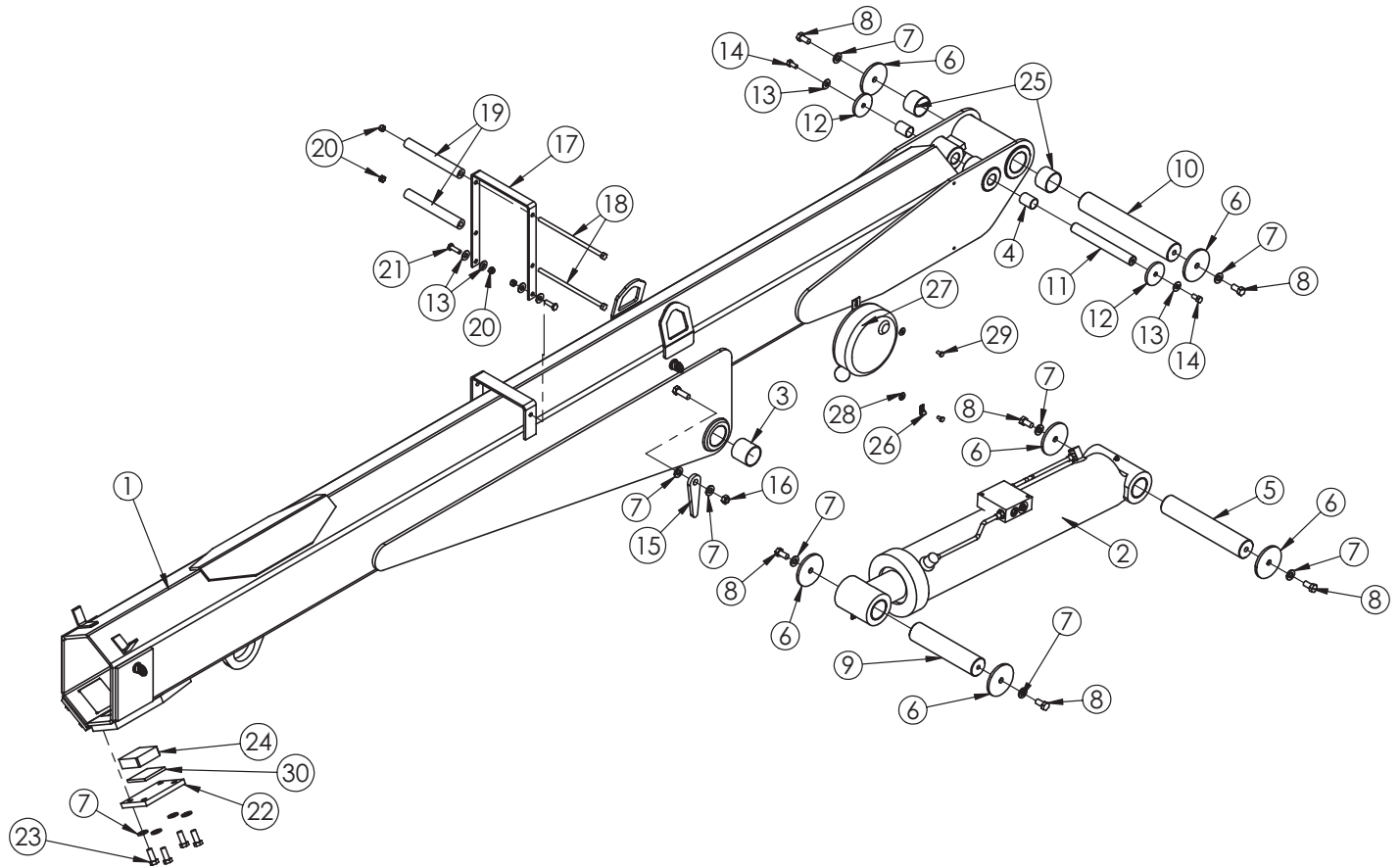

P/N 23451

ITEM	PART	DESCRIPTION	QTY.	ITEM	PART	DESCRIPTION	QTY.	ITEM	PART	DESCRIPTION	QTY.
1	34784	BOOM INNER 5728	1	11	9712	PIN 1.00X8.38 D&T	1	21	0335	CAP SCR 0.38-16X1.25 HHGR5	2
2	24144	CYLINDER ASM 9620 INNER	1	12	7403	PIN CAP 0.44X2.50X.252	2	22	13398	PLATE WEAR PAD SUPPORT 9620	2
3	4381	BUSHING 32DXR32 2.00X2.00 GARLOCK	2	13	C6353	WASHER 0.38 FLAT GR8	6	23	10666	CAP SCR 0.50-13X1.25 HHGR8	8
4	0068	BUSHING QSI-1618-24	2	14	9843	CAP SCR 0.38-16X0.75 HHGR8	2	24	13395	WEAR PAD 3.00X3.00X1.00 NYLATRON	2
5	13363	PIN 2.00X11.19 D&T	1	15	D1194	PLATE ANGLE INDICATOR	2	25	4380	BUSHING 32DXR24 2.00X1.50 GARLOCK	2
6	8377	PIN CAP 0.56X3.50X.25	6	16	C6106	NUT 0.50-13 HHGR5 NYLOC	2	26	C5606	CLAMP 0.25 BLK VINYL	1
7	D0790	WASHER 0.50 FLAT GR8	18	17	13435	BRKT ROPE GUIDE 9620	1	27	19166	CORD REEL 5728	1
8	10172	CAP SCR 0.50-13X1.00 HHGR8 ZY	6	18	12168	CAP SCR 0.38-16X9.00 HHGR5	2	28	0340	WASHER 0.25 FLAT	2
9	9711	PIN 2.00X8.88 D&T	1	19	27720	SPACER ROPE GUIDE 6620 UHMW	2	29	0478	CAP SCR 0.25-20X0.50 HHGR5	2
10	13364	PIN 2.00X12.69 D&T	1	20	0347	NUT 0.38-16 HH NYLOC	4	30	35451	PLATE AL 0.25X2.88X2.88	2

Extension Boom Assembly

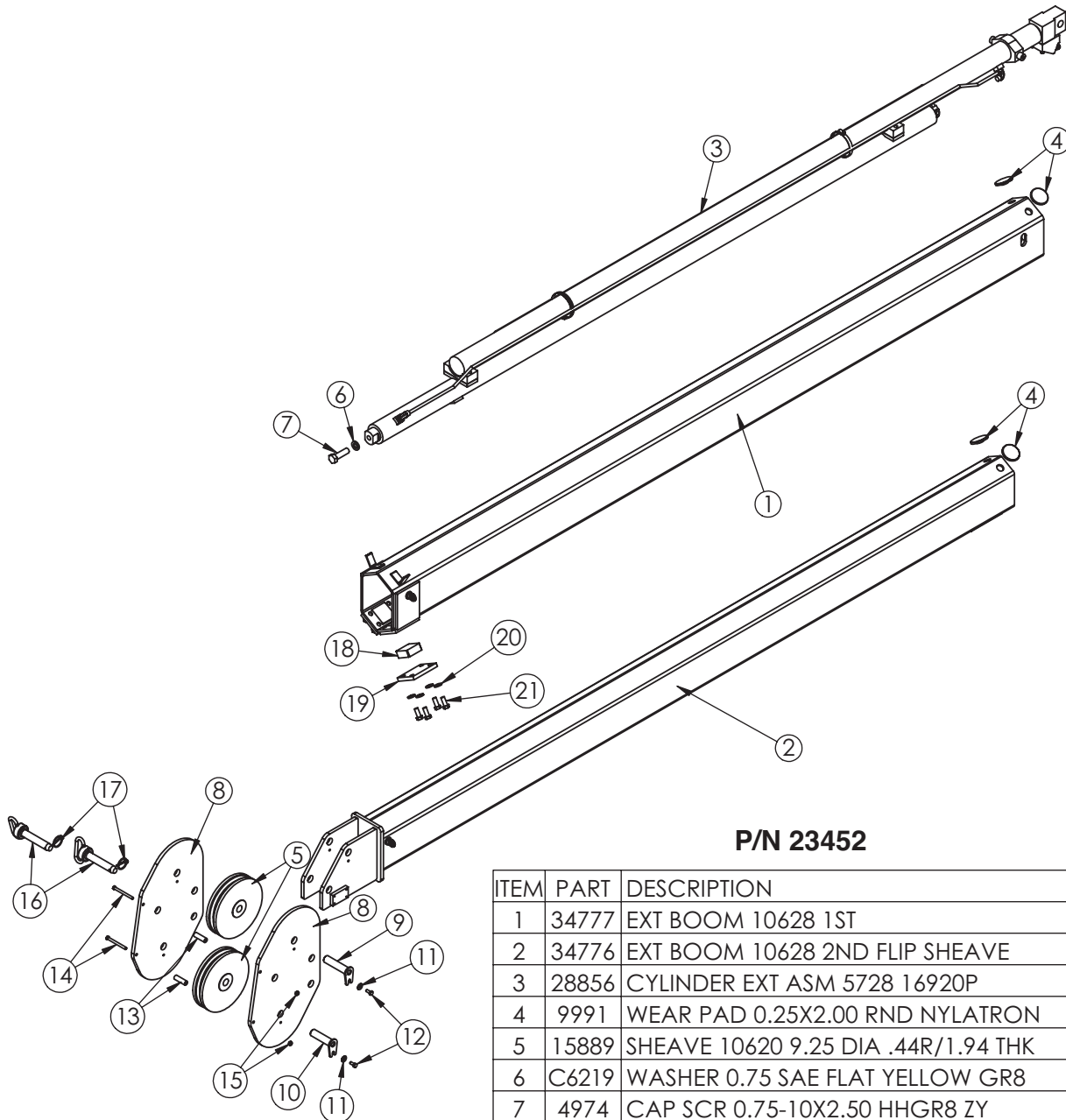

P/N 23452

ITEM	PART	DESCRIPTION	QTY.
1	34777	EXT BOOM 10628 1ST	1
2	34776	EXT BOOM 10628 2ND FLIP SHEAVE	1
3	28856	CYLINDER EXT ASM 5728 16920P	1
4	9991	WEAR PAD 0.25X2.00 RND NYLATRON	4
5	15889	SHEAVE 10620 9.25 DIA .44R/1.94 THK	2
6	C6219	WASHER 0.75 SAE FLAT YELLOW GR8	1
7	4974	CAP SCR 0.75-10X2.50 HHGR8 ZY	1
8	15998	PLATE SHEAVE MOUNTING 10620	2
9	13400	PIN TEAR DROP 1.00X4.38	1
10	13399	PIN TEAR DROP 1.00X3.81	1
11	0343	WASHER 0.31 USS FLAT ZINC	2
12	0420	CAP SCR 0.31-18X0.75 HHGR5	2
13	27719	SPACER BOOM TIP 6620 UHMW	2
14	0490	CAP SCR 0.31-18X3.50 HHGR5	2
15	0342	NUT 0.31-18 HH NYLOC	2
16	12824	PIN HITCH 1.00X4.50	2
17	5753	PIN 0.19X1.56 LYNCH	2
18	13396	WEAR PAD 2.50X2.50X1.00 NYLATRON	2
19	13397	PLATE 1ST EXT 9620 WEAR PAD	2
20	D0790	WASHER 0.50 FLAT GR8	8
21	10666	CAP SCR 0.50-13X1.25 HHGR8	8

Main Cylinder Assembly

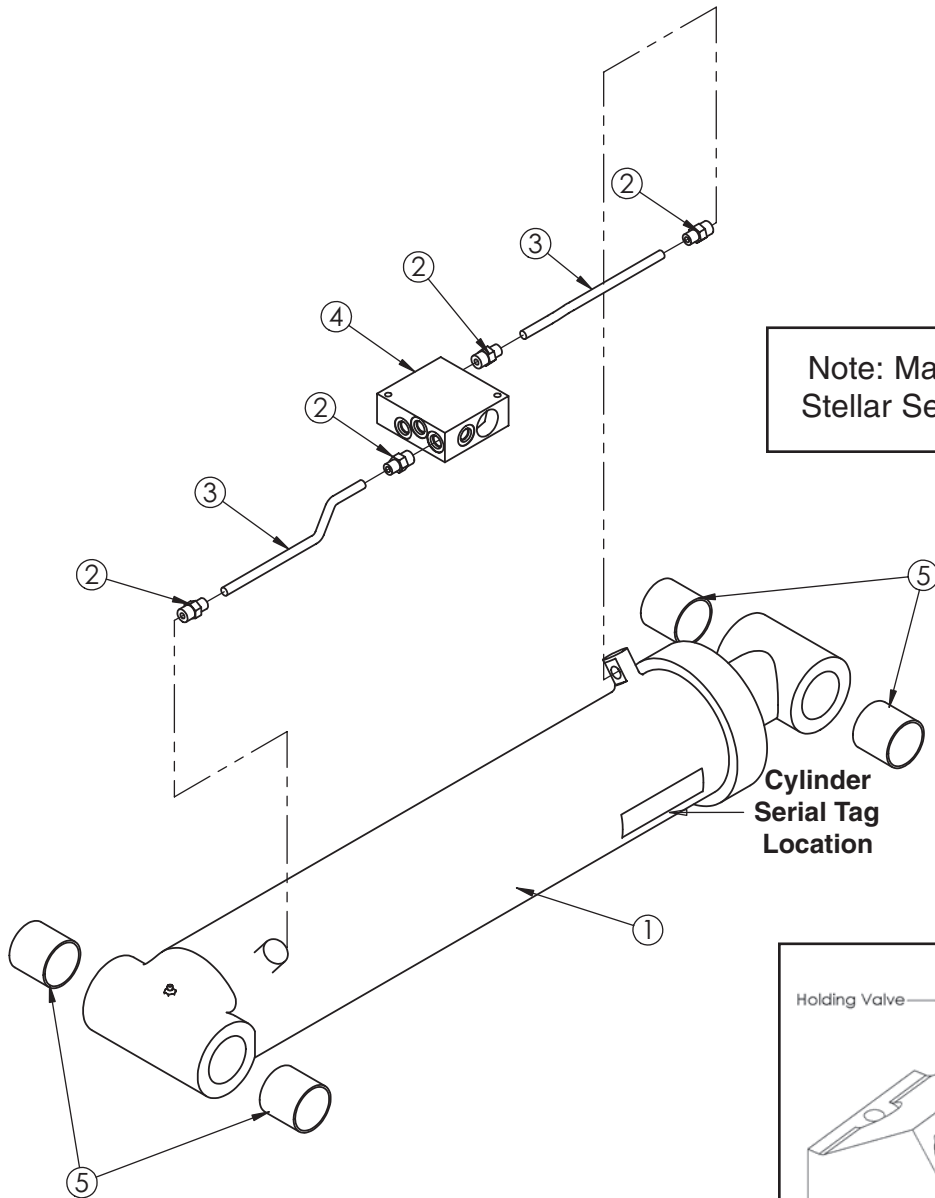

Note: Main Cylinder uses Stellar Seal Kit P/N 25081

Holding Valve Removal Procedure:

- Locate Holding Valve to be removed.
- Unlock Jam Nut, as shown.
- Turn center screw, as shown, ClockWise Direction. Important - Count the turns it takes until stopping.
- Holding valve can now be removed from manifold. Important - Before replacing valve, reset by turning the center screw the same amount of turns Counter ClockWise as in previous step.
- Reset Jam Nut.
- Valve is now removed and set at Factory Specifications.

P/N 24144

ITEM	PART	DESCRIPTION	QTY.
1	12970	CYLINDER INNER 9620 5.00X21.38	1
2	0279	FTG ADAPT 6-F5OLO-S	4
3	12158	TUBE ASM 0.38X8.88 MAIN CYL 6620	2
4	13080	MANIFOLD ASM 6620 INNER HOLDING	1
5	4381	BUSHING 32DXR32 2.00X2.00 GARLOCK	4

Extension Cylinder Assembly

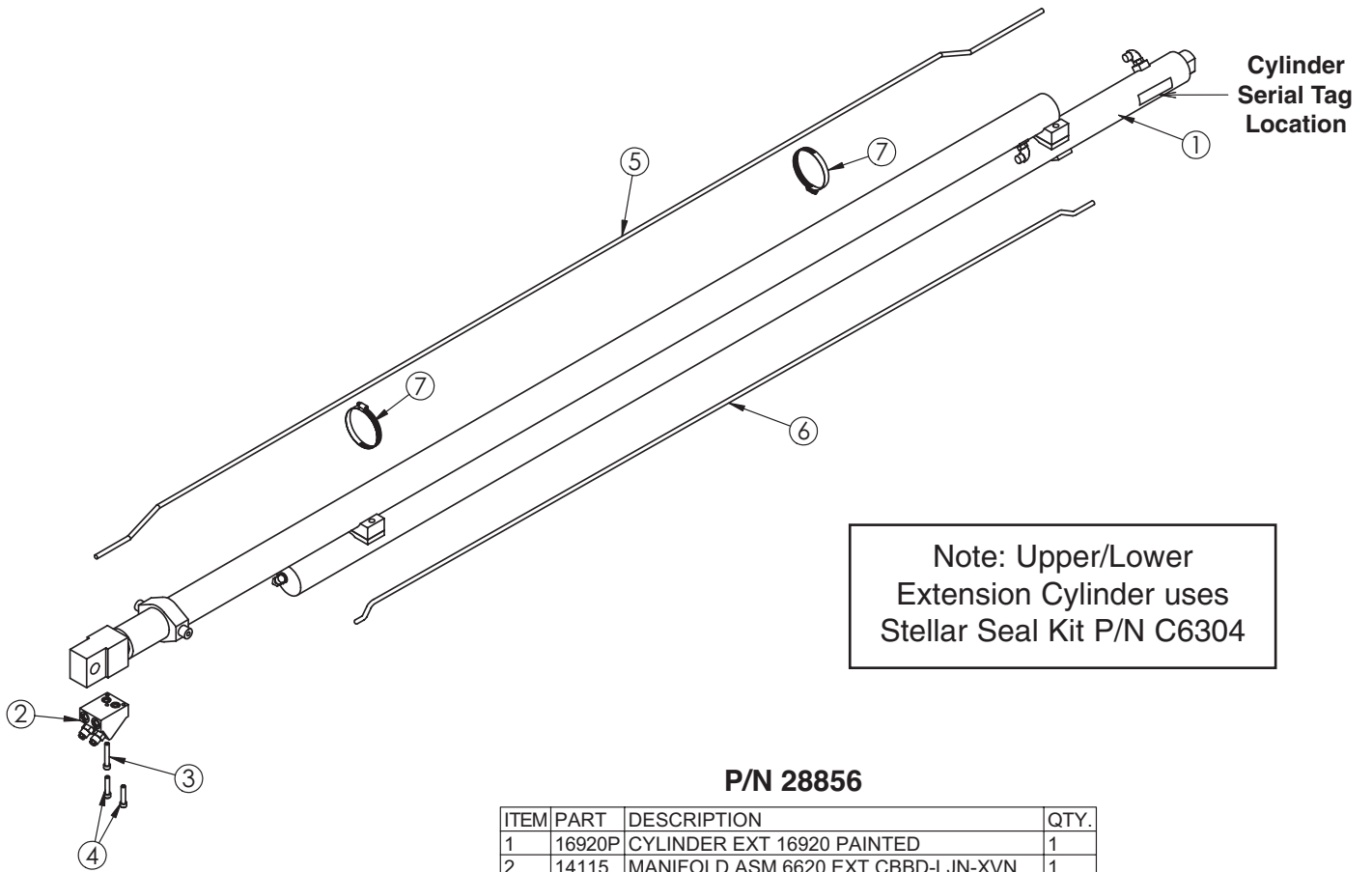

P/N 28856

ITEM	PART	DESCRIPTION	QTY.
1	16920P	CYLINDER EXT 16920 PAINTED	1
2	14115	MANIFOLD ASM 6620 EXT CBBB-LJN-XVN	1
3	14601	CAP SCR 0.38-16X2.25 SH ZC	1
4	11882	CAP SCR 0.38-16X1.75 SH ZC	2
5	17286	TUBE ASM 0.38 X LONG EXT CYL 3628	1
6	17285	TUBE ASM 0.38 X SHORT EXT CYL 5728	1
7	24729	HOSE CLAMP #52 3.00 - 3.75	2

Cable & Hook Assembly

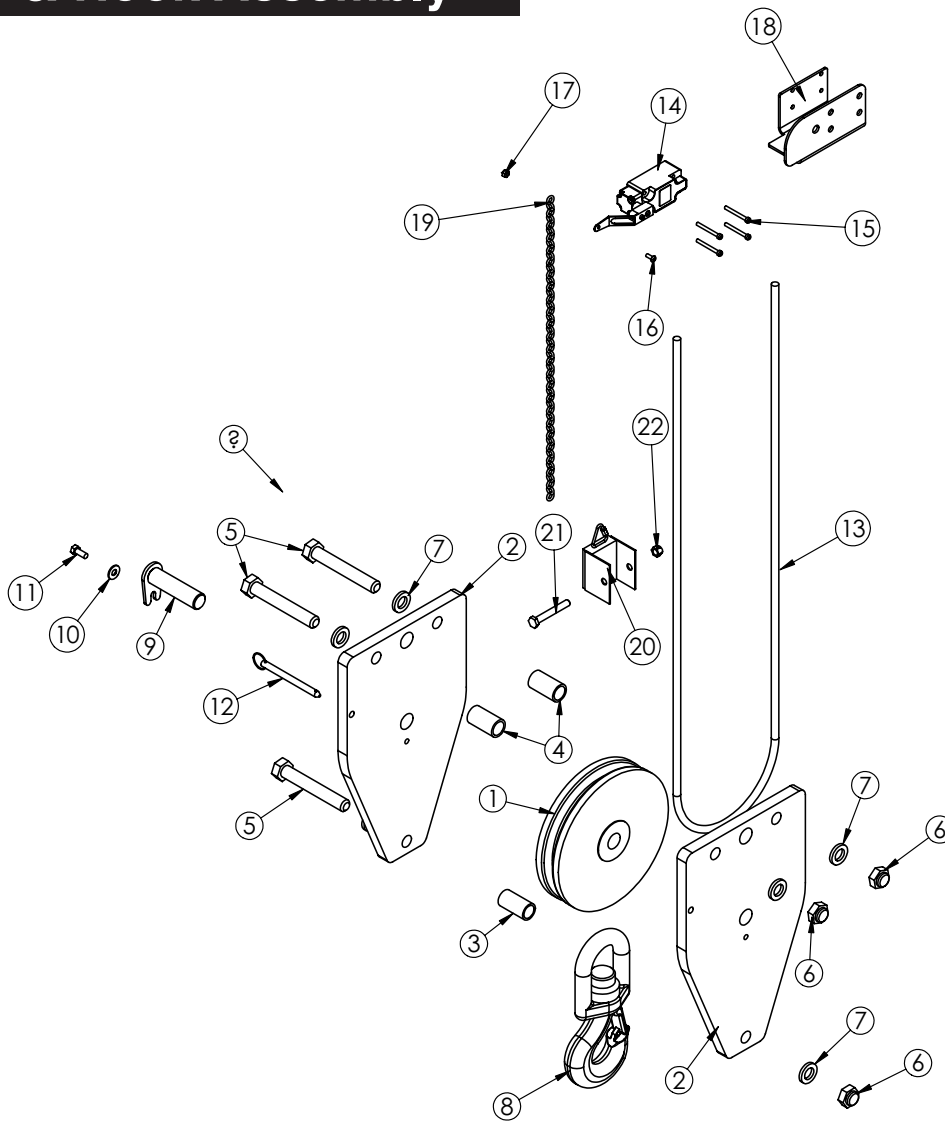

P/N 24209

ITEM	PART	DESCRIPTION	QTY.
1	15889	SHEAVE 10620 9.25 DIA .44R/1.94 THK	1
2	16000	PLATE 10620 SNATCH BLOCK	2
3	13394	SPACER 9620 SNATCH BLOCK	1
4	27811	SPACER 9620 SNATCH BLOCK UHMW	2
5	C1030	CAP SCR 0.75-10X5.00 HHGR8	3
6	C0538	NUT 0.75-10 HHGR8 NYLOC	3
7	C6219	WASHER 0.75 SAE FLAT YELLOW GR8	6
8	25831	HOOK 5 TON SWIVEL GROSSBY 1028623	1
9	13399	PIN TEAR DROP 1.00X3.81	1
10	0343	WASHER 0.31 USS FLAT ZINC	1
11	0420	CAP SCR 0.31-18X0.75 HHGR5	1
12	13436	PIN .38X4.00 QUICK RELEASE	1
13	24208	WIRE ROPE .44 6X25 IWRC-XIP 100FT	1
14	11938	SWITCH LIMIT A2B FURNAS 3SE3170	1
15	33749	SCREW #10-24X1.75 SHGR8 ZINC	4
16	D1711	CAP SCR #10-24X0.50 BTNHD SS	1
17	C4956	NUT #10-24 HH NYLOC SS	1
18	34354	ANTI 2 BLOCK COVER LH	1
19	18454	CHAIN 0.105X21.50	1
20	19994PC	WEIGHT ANTI 2 BLCK 19994 POWDERCOAT	1
21	0530	CAP SCR 0.38-16X2.75 HHGR5	1
22	0347	NUT 0.38-16 HH NYLOC	1

WIRE ROPE / SHEAVE CONFIGURATIONS

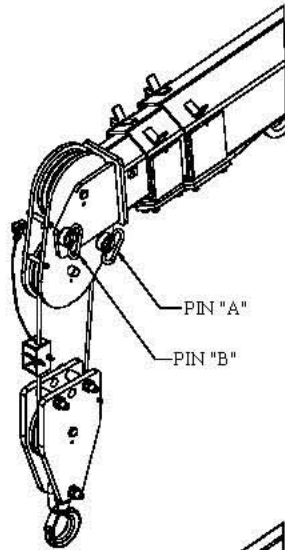

STANDARD 2 PART LINE
SHEAVE FLIPPED DOWN
CAPACITIES AS SHOWN ON
LOAD CHART

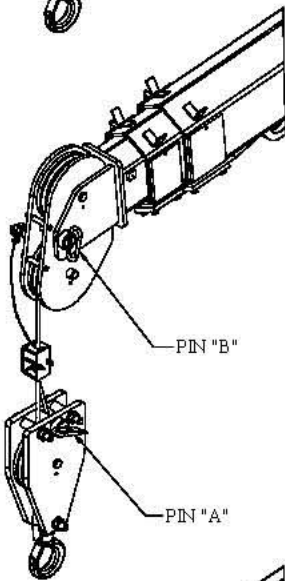

SINGLE PART LINE
SHEAVE FLIPPED DOWN

- 1.) REMOVE PIN A FROM BOOM TIP
- 2.) ROUTE WIRE ROPE THROUGH SNATCH BLOCK
- 3.) PIN WIRE ROPE TO SNATCH BLOCK AS SHOWN WITH PIN "A"

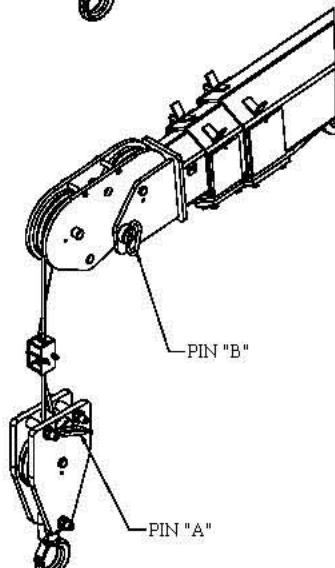

SINGLE PART LINE
SHEAVE FLIPPED UP

- 1.) REMOVE PIN B
- 2.) FLIP SHEAVE
- 3.) INSERT PIN B WITH SHEAVE IN UP POSITION

Chapter 6 - Installation

Notice: Read this Page Before Installation of the Crane

General Installation

This chapter is designed to serve as a general guide for the installation of a Stellar 9628 Telescopic Crane on a Stellar Service Body. Each installation is considered unique so certain portions of this chapter may or may not apply to your direct application. If a question should arise during the installation process, please contact Stellar Customer Service at (800) 321 3741.

This crane is designed for use with a Stellar Service Body installed on a vehicle that meets the minimum chassis requirements of the crane. Check with Stellar Industries before installing this crane on a body other than a Stellar Service Body.

WARNING!

The use of this crane on a body not capable of handling the loads imposed on it may result in serious injury or death.

Optimal Service Body for the 9628 Crane: *T2-11 Service Body*

Applicable Chassis:	19000 GVWR and up.
Cab to Axle:	84" (213.36 cm)
Body Length Nominal:	133" (337.82 cm)
Body Height:	52" (132.08 cm)
Body Width:	94" (238.76 cm)
Compartment Depth:	22" (55.88 cm)
Floor Width:	50" (127 cm)
Net Weight:	3600 lbs (1632.93 kg)

Installation Notice

According to Federal Law (49 cfr part 571), each final-stage manufacturer shall complete the vehicle in such a manner that it conforms to the standards in effect on the date of manufacture of the incomplete vehicle, the date of final completion, or a date between those two dates. This requirement shall, however, be superseded by any conflicting provisions of a standard that applies by its terms to vehicles manufactured in two or more stages.

Therefore, the installer of Stellar cranes and bodies is considered one of the manufacturers of the vehicle. As such a manufacturer, the installer is responsible for compliance with all applicable federal and state regulations. They are required to certify that the vehicle is in compliance with the Federal Motor Vehicle Safety Standards and other regulations issued under the National Traffic and Motor Vehicle Safety Act.

Please reference the Code of Federal Regulations, title 49 - Transportation, Volume 5 (400-999), for further information, or visit <http://www.gpoaccess.gov/nara/index.html> for the full text of Code of Federal Regulations.

Notice:

PTO and Pump installation instructions are provided by the proper manufacturers. For more information on which PTO and Pump fit your application, please contact your local Stellar Distributor or Stellar Customer Service.

The following pages will give a basic overview of the installation process for the Stellar 9628. Please read thru them entirely and obtain a clear understanding of the process before proceeding.

Installation Overview

1. Determine that the mounting location for the 9628 crane is at least 20" x 21" (50.8 x 50.8 cm).
2. Use the detail on page 6-2 to drill 1.06" diameter holes into the mounting plate. Run tap on the threads of the base to be sure they are clean.
3. Use a crane or lifting device capable of lifting the weight of the Stellar crane. The Stellar 9628 weighs approximately 2850 lbs (1295 kg). **Note: cranes are shipped with rotation positioned at 200 degrees of 400 degree system.** This will allow for easy installation of the crane and permanent connection of all hydraulic and electrical components prior to repositioning into the crane saddle.
4. Connect straps or chain from the lifting device to the lifting rings on the Stellar 9628.
5. Use six (6) 3" x 1" #8 bolts and six (6) #8 flat washers.
6. Install a washer on each bolt.
7. Apply Loctite Thread locker #277 to the bolts.
8. Using the lifting device, lower the Stellar 9628 just above the crane compartment and start the bolts. Have someone assist in leveling the crane. **Note: the rotation motor should be to the door side of crane compartment and the boom should be extended back over the rear bumper.**
9. Secure the crane using the mounting hardware provided (see the detail on page 6-2). **Note: longer or shorter cap screws may be required – recommended thread engagement into crane base is 1.75" – use grade 8, zinc plated cap screws only.**
10. Torque the cap screws to 680 ft-lbs.
11. Remove supporting crane.
12. Hook-up hydraulics and electrical using the schematics provided in *Chapter 8 - Hydraulics - Electrical*. **Note: If questions should arise during any portion of this installation, please contact Stellar Customer Service at (800) 321-3741.**

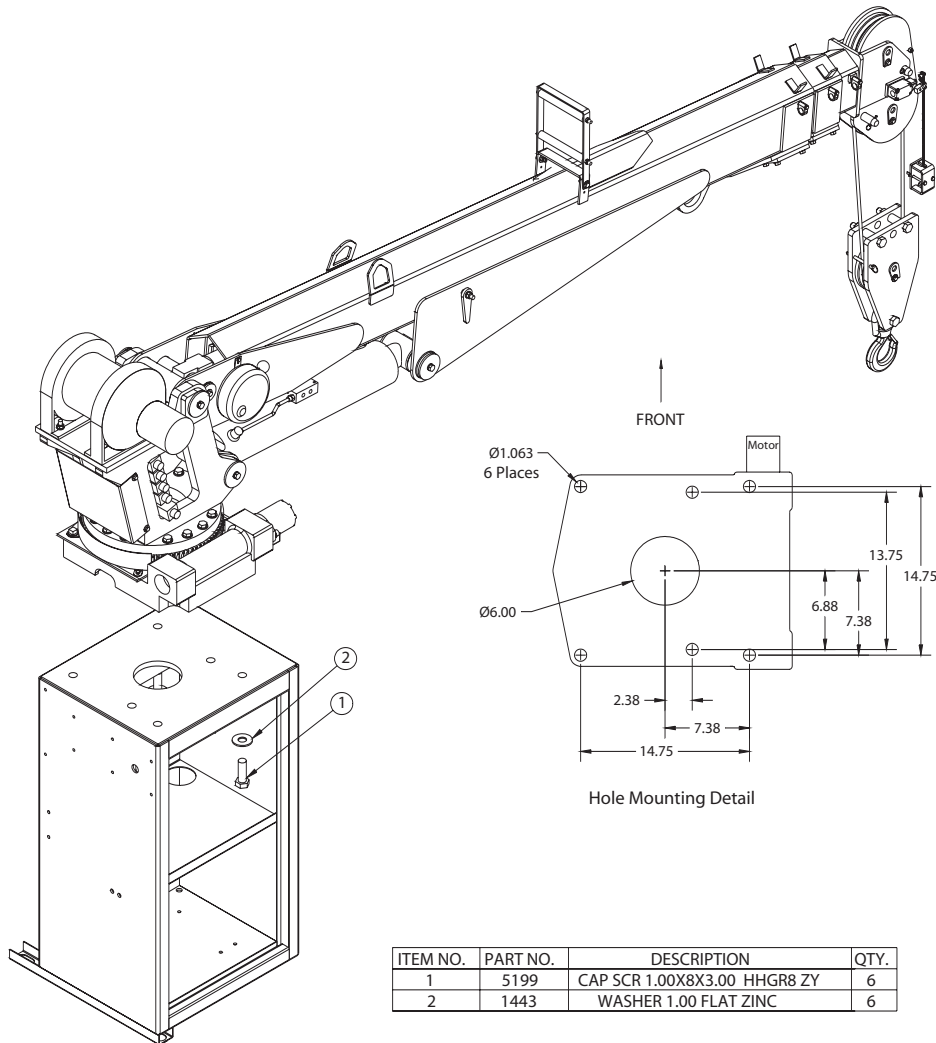

Installation Details

1. Determine that the mounting location for the 9628 crane is at least 20" x 21" (50.8 x 53.3 cm).

2. Use the detail on page 6-2 to drill 1.06" diameter holes into the mounting plate. Run tap on the threads of the base to be sure they are clean.



3. Use a crane or lifting device capable of lifting the weight of the Stellar crane. The Stellar 9628 weighs approximately 2850 lbs (1295 kg). **Note: cranes are shipped with rotation positioned at 200 degrees of 400 degree system.** This will allow for easy installation of the crane and permanent connection of all hydraulic and electrical components prior to repositioning into the crane saddle.



4. Connect straps or chain from the lifting device to the lifting rings on the Stellar 9628.

5. Use six (6) 3" x 1" #8 bolts and six (6) #8 flat washers.

6. Install a washer on each bolt.

7. Apply Loctite Thread locker #277 to the bolts.

8. Using the lifting device, lower the Stellar just above the crane compartment and start the bolts. Have someone assist in leveling the crane. **Note: the rotation motor should be to the door side of crane compartment and the boom should be extended back over the rear bumper.**



Installation Details Continued...

9. Secure the crane using the mounting hardware provided (see the detail on page 6-2). **Note: longer or shorter cap screws may be required – recommended thread engagement into crane base is 1.75” – use grade 8, zinc plated cap screws only.**

10. Torque the cap screws to 680 ft-lbs.



11. Remove supporting crane.



12. Hook-up hydraulics and electrical using the schematics provided in *Chapter 8 - Hydraulics - Electrical*.

Note: If questions should arise during any portion of this installation, please contact Stellar Customer Service at (800) 321-3741.

Stability Procedure

Definition of Stability for the Stellar Telescopic Crane Products:

A truck is stable until the load cannot be lifted off the ground with the winch, without tipping over the truck. Every Stellar crane installed must be tested for stability to determine the actual load capacity of the final truck package. The actual test data must be recorded and supplied with the truck at the time of in-service and should be kept with the truck at all times. The following procedure will test the truck package for stability and will provide a stability capacity chart. The load limit information shown on the stability capacity chart is formulated on 85% tipping.

Set Up:

1. Locate the truck on a test course in position for loading and engage travel brakes.
2. Set outriggers so that they make contact with firm, level footings.
3. Operate the crane under partial load to assure operator proficiency and proper machine function.

9628 Stability Data

Max Horizontal Reach: 339" (From the center of rotation to boom tip)
Stability Test Weight: 2270 lbs.

Test Procedure

1. Rotate the crane into Zone 1 position.
2. With the crane fully retracted and the boom horizontal, winch the test weight off the ground. Note: Keep weight within six inches of the ground at all times.
3. Extend the boom outward until full extension has been reached or until the truck becomes unstable (Again, use the winch to keep the weight within six inches of the ground.)
4. If the boom goes full extension without becoming unstable, the crane is termed stable for this zone and 100% can be written in the Zone 1 data box.
5. If the truck becomes unstable prior to going full extension, retract the boom until the truck becomes stable and measure the horizontal reach in this position (center of rotation to boom tip). This is the stable horizontal reach for this zone. Stable horizontal reach divided by Maximum horizontal reach multiplied by 100 equals the percentage of rated capacity for this zone. Use the following formula to determine the percentage of rated capacity:

$$\frac{\text{Stable Horizontal Reach}}{\text{Max Horizontal Reach}} \times 100 = \text{Percentage of Rated}$$

6. Record this number in the data box for Zone 1. This is the revised capacity due to stability for this zone.
7. Repeat this procedure for each zone until the worksheet is completed.
8. This is the revised capacity based on stability of this package.

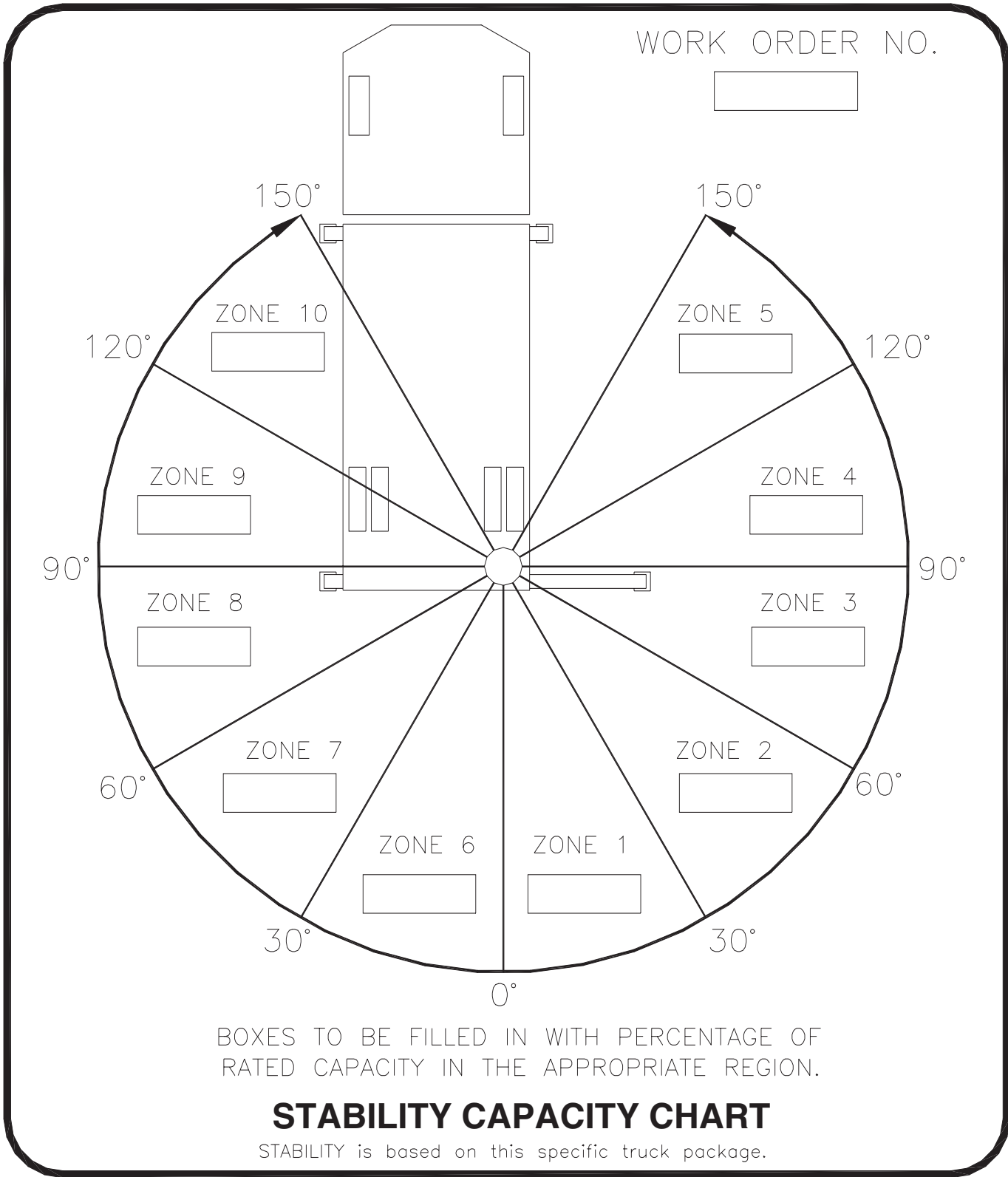

For a decal version of this capacity chart, please contact Stellar Customer Service at (800) 321-3741

Chapter 8 - Hydraulics - Electrical

Control Kit

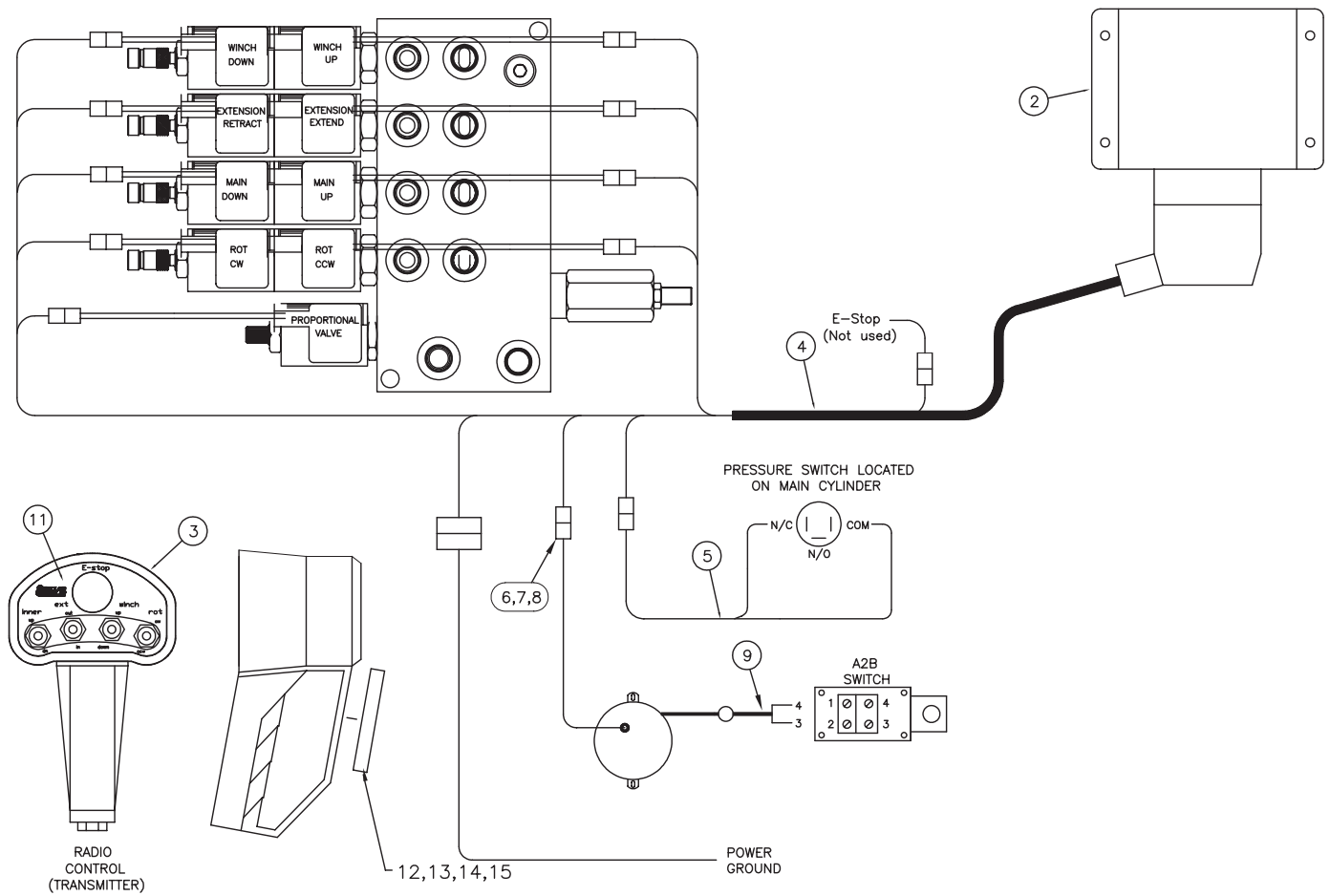

P/N 18932

15	0333	NUT 0.25-20 HHGR5 NYLOC	1
14	C6021	CAP SCR 0.25-20X0.75 BTNHD SS	1
13	6832	DECAL MAGNET COVER-2.94DIA	1
12	6629	MAGNET 70# 2.80 DIA	1
11	18469	Decal - 4 function - Mech Cranes	1
10	16255	BATTERY CHARGER W/BTRY 110-3.6V	1
09	10965	CABLE GROMMET	1
08	10978	CONTACT M/TERM SHROUD	2
11	18469	Decal - 4 function - Mech Cranes	1
10	16255	BATTERY CHARGER W/BTRY 110-3.6V	1
09	10965	CABLE GROMMET	1
08	10978	CONTACT M/TERM SHROUD	2
07	8384	CABLE SEAL	2
06	9752	CONNECT 2 PIN SHROUD	1
05	13004	WIRE HARNESS PRESSURE SWITCH 6620	1
04	17744	WIRE HARNESS RADIO/VB	1
03	11833	TRANSMITTER - RADIO (PART OF 1)	REF
02	11847	RECEIVER - RADIO (PART OF 1)	REF
01	11832	RADIO CONTROLLER ASSEMBLY	1
ITEM	PART No.	DESCRIPTION	QTY

Control Kit - 2 Speed Winch Version

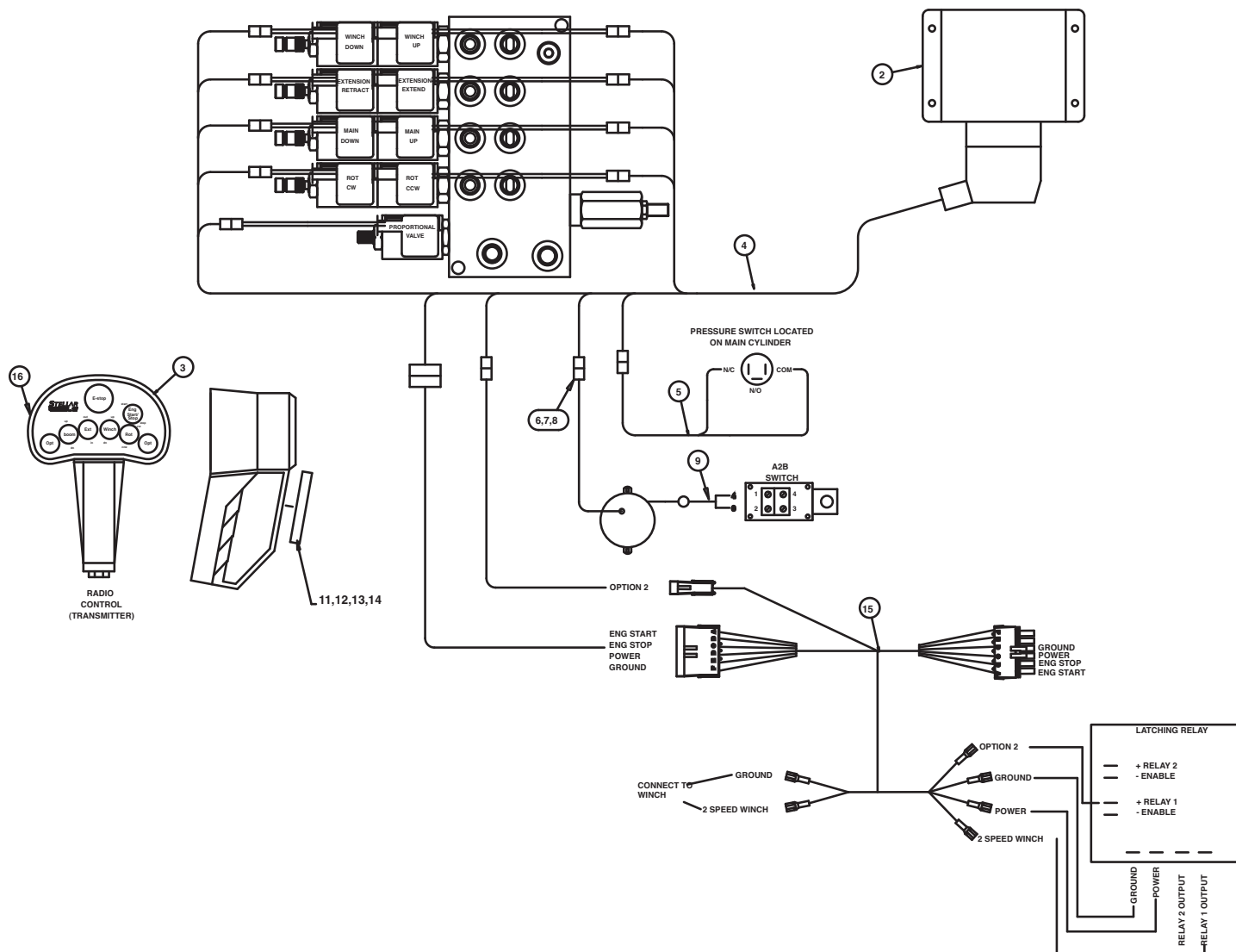

PN 27974

16	27975	DECAL 2-SPEED OPERATION	1
15	27969	WIRE HARNESS 9628 2 SPEED WINCH	1
14	0333	NUT 0.25-20 HHGR5 NYLOC	1
13	C6021	CAP SCR 0.25-20X0.75 BTNHD SS	1
12	6832	DECAL MAGNET COVER-2.94DIA	1
11	6629	MAGNET 70# 2.80 DIA	1
10	16255	BATTERY CHARGER W/BTRY 110-3.6V	1
09	10965	CABLE GROMMET	1
08	10978	CONTACT M/TERM SHROUD	2
07	8384	CABLE SEAL	2
06	9752	CONNECT 2 PIN SHROUD	1
05	13004	WIRE HARNESS PRESSURE SWITCH 6620	1
04	12134	WIRE HARNESS RADIO/VB	1
03	11834	TRANSMITTER - RADIO (PART OF 1)	REF
02	11847	RECEIVER - RADIO (PART OF 1)	REF
01	11835	RADIO CONTROLLER ASSEMBLY	1
ITEM	PART No.	DESCRIPTION	QTY

Hydraulic Kit

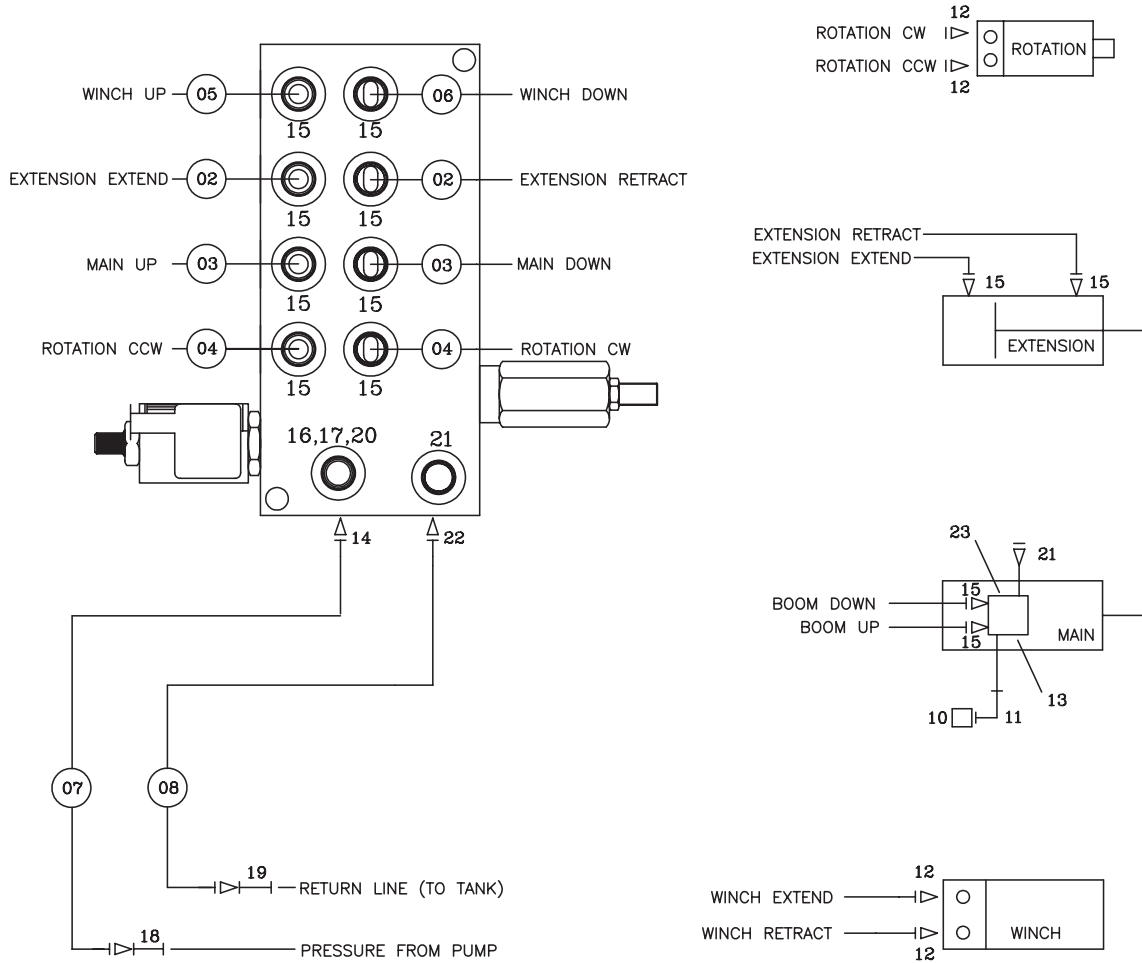

P/N 13971

24			
23	9803	VALVE C-BAL	REF
22	C1175	FTG ELL 8-V5OLO-S	1
21	C4961	PLUG STR HOLLOW HEX 0.38 6-HP50N	2
20	D1430	FTG ADAPT O'RING FMP 6-1/4 F50G-S	1
19	12172	FTG SWIVEL 0.50 FS/FS PS81 JMJM-8-8	1
18	12171	FTG SWIVEL 0.38 FS/FS PS81 JMJM-6-6	1
17	6397	GAUGE OIL LF 2.5" 0-5000 CBM	1
16	C5908	FTG 0.25 ML ELL	1
15	0279	FTG ADAPT 6 F5OLO-S	12
14	D1193	FTG ADAPT 6-V5OLO-S	1
13	11991	VALVE C-BAL PLUG	REF
12	D1302	FTG ST TH ELB 90 DEG 6-10 C5OLO	4
11	3861	FTG ML FM O'RING 90 DEG	1
10	4587	SWITCH PRES OVERLD 744.6-S03R-3200N	1
09			
08	25022	HOSE-HYD .50 X 5	1ref
07	25021	HOSE-HYD .38 X 6	1ref
06	14638	HOSE-HYD .38 X 16	1ref
05	14637	HOSE-HYD .38 X 14	1ref
04	13030	HOSE-HYD .38 X 39	2ref
03	13029	HOSE-HYD .38 X 22.50	2ref
02	13028	HOSE-HYD .38 X 17	2ref
01	13027	HOSE KIT,9620 CRANE (incl:2-11)	1
ITEM	PART No.	DESCRIPTION	QTY

Hydraulic Kit - 2 Speed Winch Version

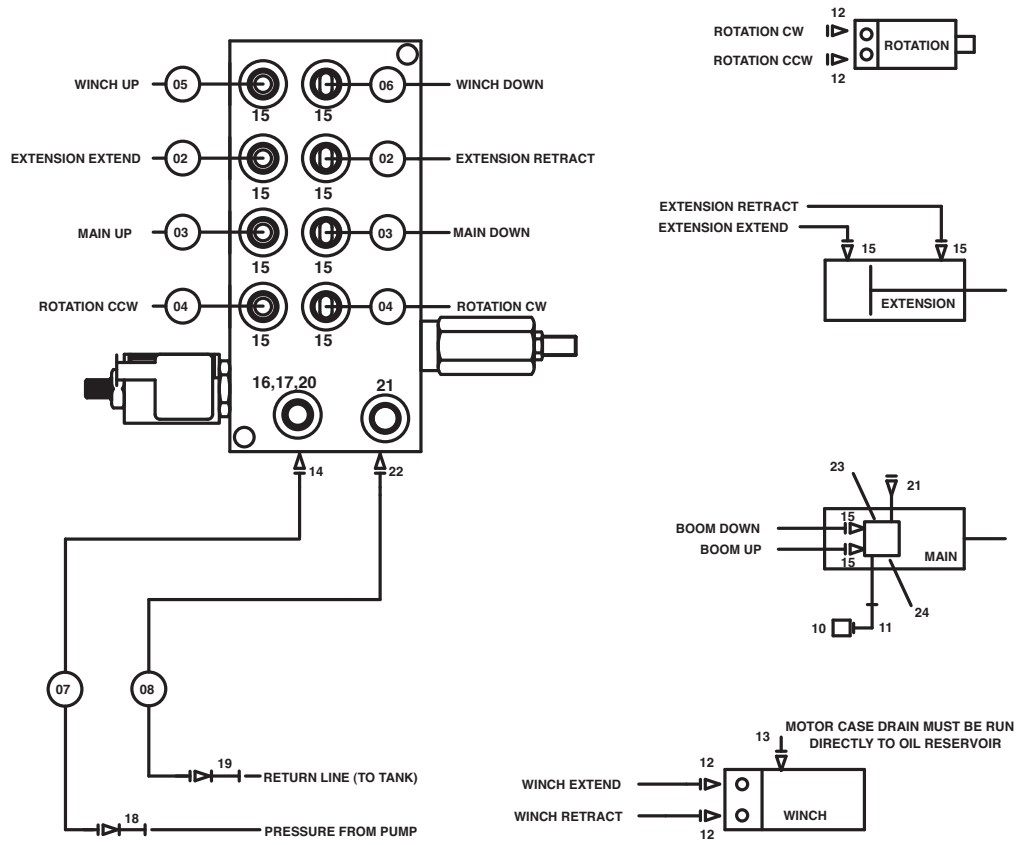

PN 27976

ITEM	PART No.	DESCRIPTION	QTY
24	11991	VALVE C-BAL PLUG	REF
23	9803	VALVE C-BAL	REF
22	C1175	FTG ELL 8-V5OLO-S	1
21	C4961	PLUG STR HOLLOW HEX 0.38 6-HP5ON	2
20	D1430	FTG ADAPT O'RING FMP 6-1/4 F50G-S	1
19	12172	FTG SWIVEL 0.50 FS/FS PS81 JMJM-8-8	1
18	12171	FTG SWIVEL 0.38 FS/FS PS81 JMJM-6-6	1
17	6397	GAUGE OIL LF 2.5" 0-5000 CBM	1
16	C5908	FTG 0.25 ML ELL	1
15	0279	FTG ADAPT 6 F5OLO-S	12
14	D1193	FTG ADAPT 6-V5OLO-S	1
13	C0338	FTG MF/MSTR 90 6-C5OLO-S	1
12	D1302	FTG ST TH ELB 90 DEG 6-10 C5OLO	4
11	3861	FTG ML FM O'RING 90 DEG	1
10	4587	SWITCH PRES OVERLD 744.6-S03R-3200N	1
09	.	.	.
08	25022	HOSE-HYD .50 X 5	1ref
07	25021	HOSE-HYD .38 X 6	1ref
06	27978	HOSE-HYD .38 X 20	1ref
05	27979	HOSE-HYD .38 X 13	1ref
04	13030	HOSE-HYD .38 X 39	2ref
03	13029	HOSE-HYD .38 X 22.50	2ref
02	13028	HOSE-HYD .38 X 17	2ref
01	27977	HOSE KIT,9628 2-SPEED (incl:2-8)	1
ITEM	PART No.	DESCRIPTION	QTY

Valve Bank

P/N 24685

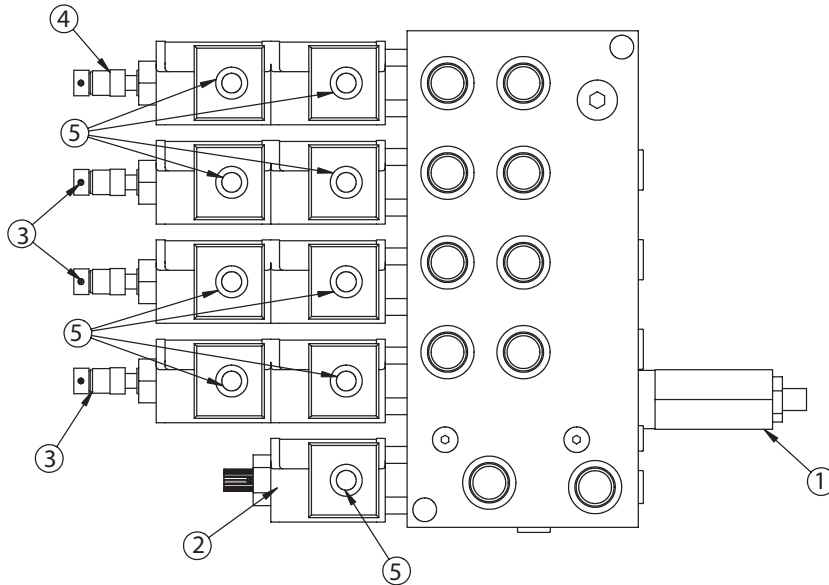

Valve Identification

Valve Item #3 P/N 25371-GS0457

Valve Item #4 P/N 25372-GS0459

ITEM	PART	DESCRIPTION	QTY
1	25367	RELIEF VALVE 24685/24690	1
	25368	SEAL KIT 25367	
2	24960	VALVE FLW CTRL PRP/JP04C3150N 0-8	1
	25369	SEAL KIT 24960/25381	
3	25371	VALVE SOLND 3 POS 4 WAY TAND G04571	3
4	25372	VALVE SOLND 3 POS 4 WAY OPEN G04591	1
	25373	SEAL KIT 25371/25372	
5	25370	COIL 12VDC PACKARD MALE 24685/24690	9

HYDRAULIC SCHEMATIC

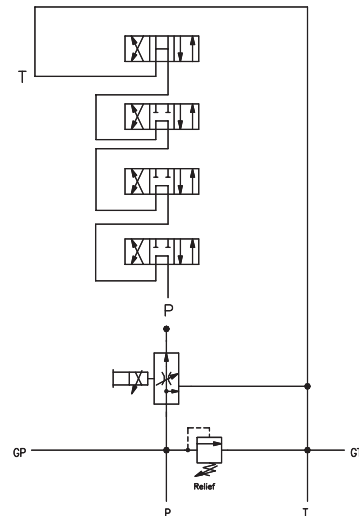
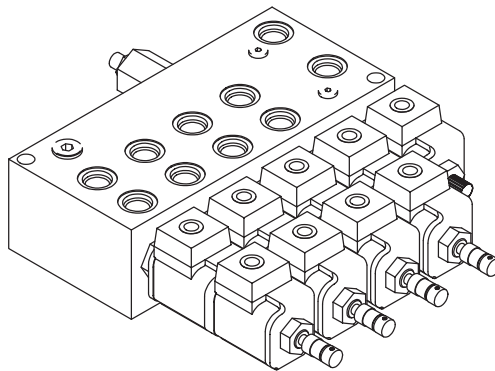

Hydraulic Installation

1. After mounting, locate the pressure and return lines. Note: Pressure line is 3/8" hose; Return line is 1/2" hose. Hoses are terminated using swivel fittings.
2. Install hydraulic lines per diagram below. Note: Outrigger valve supplies oil to crane using the Power Beyond feature.
3. Install hydraulic reservoir with return filter. Attach pump pressure line to valve, return link to tank.
4. Fill system with hydraulic oil (Mobil DTE-13M is recommended).

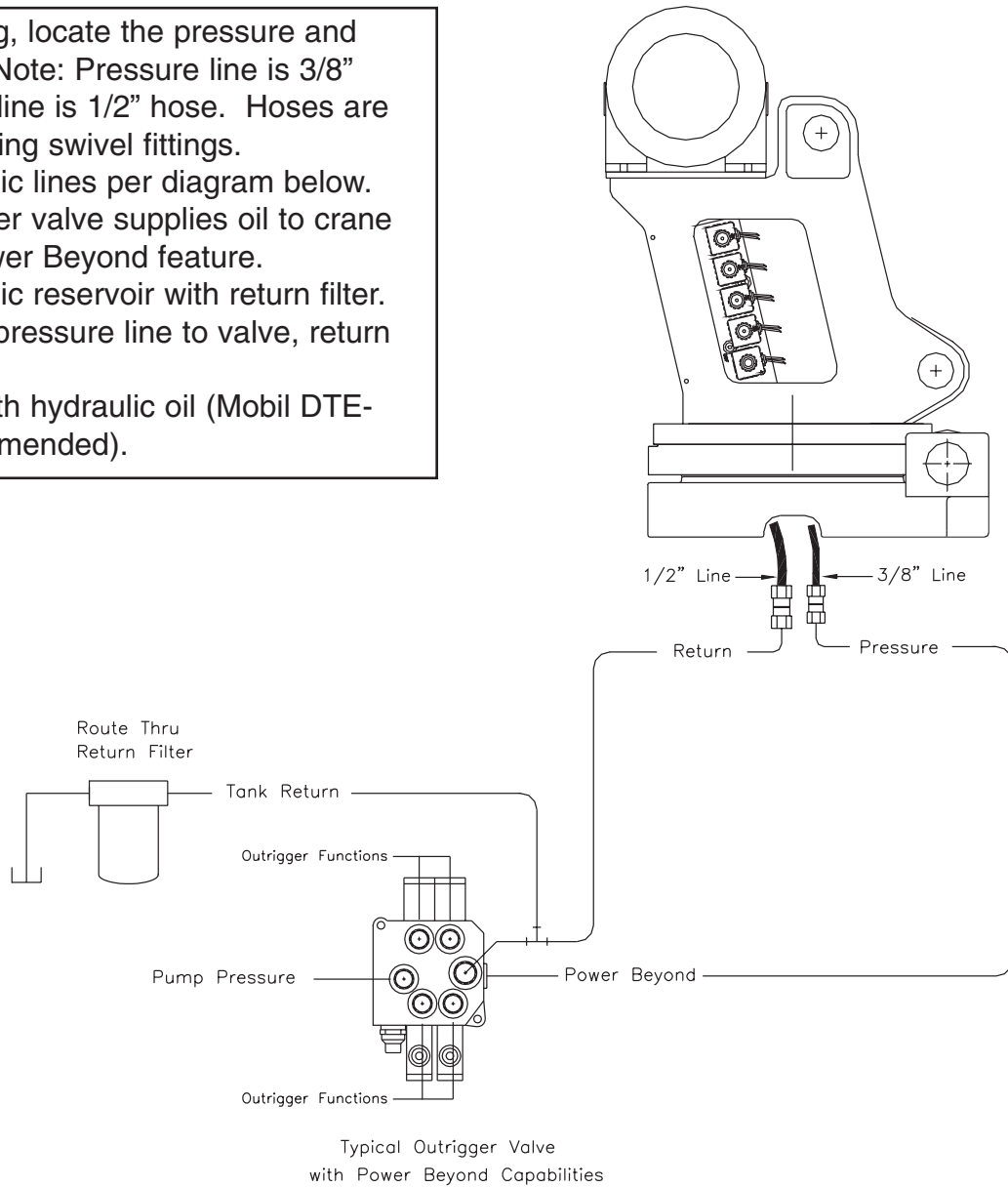

Hydraulic System

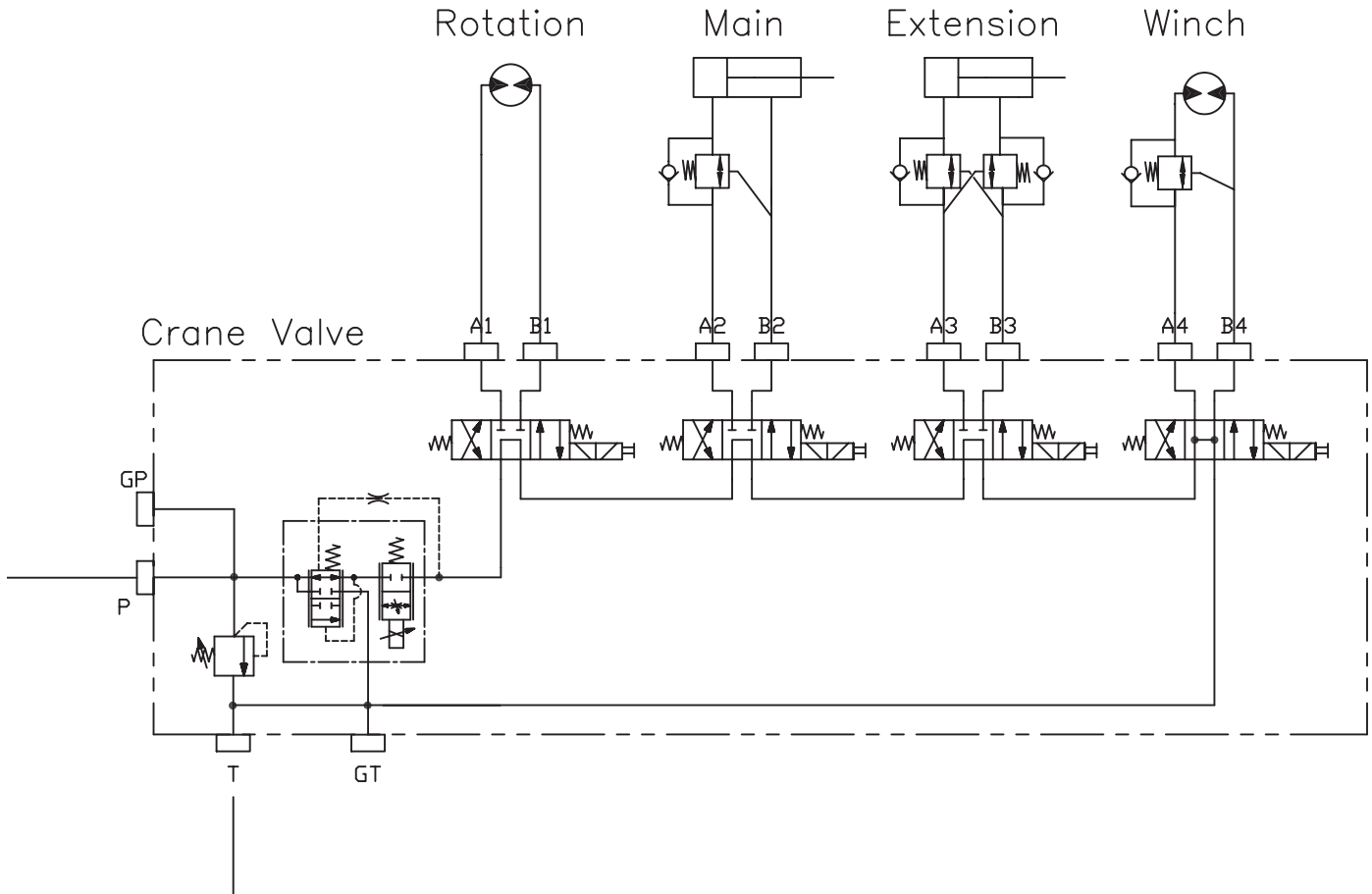

Chapter 9 - Replacement Parts

PART#	DESCRIPTION	SUGGESTED QTY
C6069	HYDRAULIC SWING MOTOR	1
25367	RELIEF VALVE	1
25368	SEAL KIT - RELIEF VALVE	1
24960	FLOW CONTROL VALVE	1
25369	SEAL KIT - FLOW CONTROL VALVE	1
25371	SOLENOID VALVE TAND G04571	2
25372	SOLENOID VALVE OPEN G04591	1
25373	SEAL KIT - SOLENOID VALVE	2
25370	COIL - 12VDC	1
25081	SEAL KIT - MAIN CYLINDER	1
C6304	SEAL KIT - UPPER/LOWER EXTENSION CYLINDER	2
13080	MANIFOLD ASM - MAIN CYLINDER	
9803	C-BALANCE VALVE	1
11991	PLUG - C-BALANCE	1
14115	MANIFOLD ASM - EXTENSION CYLINDER	
14390	O'RING - MANIFOLD ASM EXT. CYLINDER	2
4587	PRESSURE SWITCH	1
6397	HYD PRESSURE GUAGE	1
C2027	O'RING - # 4 FACE SEAL	4
C2028	O'RING - # 6 FACE SEAL	4
C2029	O'RING - # 8 FACE SEAL	4
D1245	O'RING - # 4 SAE	4
D1246	O'RING - # 6 SAE	4
D1247	O'RING - # 8 SAE	4
12158	TUBE ASM - MAIN CYLINDER	1
17285	TUBE ASM - EXTENSION CYLINDER	1
17286	TUBE ASM - EXTENSION CYLINDER	1
4380	BUSHING 2.00" x 1.50"	2
4381	BUSHING 2.00" x 2.00"	2
#0068	BUSHING	2
13395	WEAR PAD 3.00"X3.00"X1.00"	2
13396	WEAR PAD 2.50"X2.50"X1.00"	2
9991	WEAR PAD 2.50" ROUND	4
8377	PIN CAP .56 X 3.50 X .25	2
7403	PIN CAP .44 X 2.50 X .25	2
D0790	WASHER 0.50 FLAT GR8	4
10172	CAP SCR. 0.50-13 X 1.00"	4
15889	SHEAVE	1
24208	WIRE ROPE	1
12824	HITCH PIN 1.00" X 4.50"	1
13436	QUICK RELEASE PIN .38 X 4.00"	1
11938	LIMIT SWITCH	1
19166	CORD REEL	1
12280	3.6V BATTERY	1
19994PC	ANTI - 2 BLOCK WEIGHT	1
5753	LYNCH PIN	1

Call 800-321-3741 to Order

Chapter 10 - Troubleshooting

This chapter will list a number of potential problems that may occur while operating the crane. Most problems are easily solved using the solutions portion of this chapter. If problems persist, please contact Customer Service at Stellar Industries 1-800-321-3741.

Problem: Crane will not operate.

Solutions:

- Make sure that the parking brake is engaged.
- Make sure that the PTO is engaged.
- Make sure that there is 12V power going to the radio receiver. If there is no power going to the receiver, trace back to the power source and check for a blown fuse or loose ground connection. Refer to radio remote troubleshooting guide at the end of this chapter.
- Make sure that the transmitter batteries are fully charged. (Rechargeable batteries are good for 11 months or 200 charges)
- Make sure that the hydraulic pump is operating at its rated flow or GPMs. Check the flow by using the flow meter to determine the GPMs. It is possible that the hydraulic pump is getting weak. If this is suspected, contact Stellar Customer Service.

Problem: Crane will operate manually but will not operate electrically.

Solutions:

- Make sure that there is 12V power going to the radio receiver. If there is no power going to the receiver, trace back to the power source and check for a blown fuse or loose ground connection. Refer to radio remote troubleshooting guide at the end of this chapter.
- Make sure that the parking break is engaged.
- Make sure that the parking break switch is working properly. Check the parking break switch by performing a continuity test. If the switch is defective, simply replace it.

Problem: Not all crane functions operate using the radio remote transmitter or crane operates intermittently.

Solutions:

- Make sure that the toggle switch is working properly. If the switch is defective, simply replace it.
- Make sure that there is power going from the valve bank coil solenoid or to the function that will not operate. If no power is going to the coil solenoid, check wiring connections on wire harness plug connector for broken wires, loose connection or poor crimp. If power is going to the solenoid valve, it may not be opening to allow hydraulic oil to the function that is not operating. Remove stem valve, thoroughly clean, lubricate, and reinstall valve. Do not over tighten. If the valve will not close, simply replace it.

Problem: Two functions operate at the same time while only toggling one function.

Solutions:

- Make sure that the solenoid valves are all in the center position.
- Determine the function that is operating on its own. Check to see if there is power going to the solenoid valve from a function that should not be operating. If voltage is present at the solenoid valve without operating the function, the toggle switch has failed and is stuck in the "on" function. If no voltage is present, the solenoid valve may be partially open. Remove the stem valve, thoroughly clean, lubricate, and reinstall the valve. Do not over tighten. If valve will not close, simply replace it.

Problem: Winch brake will not hold.

Solutions:

- Check to see if the back pressure on the return line of the winch is greater than 50 psi. Try operating a function other than the winch. Operate the function both ways and then stop. Now operate the winch. If the brake still does not hold, contact Customer Service at Stellar.

Problem: Winch will not hold load.**Solutions:**

- Make sure that the object being lifted does not exceed the rated capacity of the winch. Refer to the capacity chart. If the object is within the rated capacity, reposition the truck and try to lift the object without using the crane boom extensions.
- Make sure that the relief valve on the winch is set correctly. Readjust the relief valve if necessary.

Problem: Crane only operates at full speed.**Solutions:**

- Check to see if there is 12V power constantly going to the proportional valve. If 12 volts are showing up at the proportional valve without pulling on the transmitter trigger, the handle/trigger assembly may be defective. If 8 volts are showing at the proportional valve, it is possible that the valve is stuck open and will not close. Remove the valve, clean it thoroughly and reinstall. Do not over tighten. If the problem persists, replace the proportional valve.
- Check to see if the manual override on the proportional valve is turned out. Turn the manual override on the flow valve in.

Problem: Crane operates slowly.**Solutions:**

- Make sure that the crane is receiving the recommended GPMs to operate.
- Check the level of hydraulic fluid in the reservoir. Add fluid as needed.
- Check to see if the valve bank orifice is plugged. If so, replace the orifice. Call Stellar Customer Service for instructions.
- Make sure the proportional valve is receiving 12V power when fully engaging the transmitter trigger. If there is not 12V power while pulling the trigger, check for loose connections inside the transmitter or replace the handle trigger assembly. If the proportional valve is receiving 12 volts, loosen the solenoid holding nut and check to see if the solenoid coil is magnetizing. If no polarity is present, replace the coil. If coil is magnetizing, remove the stem valve, thoroughly clean, lubricate, and reinstall the valve.

Problem: Winch “Up”, Main Cylinder “Down”, and Extension Cylinder “Out” are the only functions that don’t operate.**Solutions:**

- Make sure that the unit 2-block weight and chain on the end of the boom are straight so they slide easily along the wire rope cable.
- Make sure that the limit switch is working properly. Disconnect the two wires connected to the limit switch and tie them together. If all functions operate, replace the limit switch.
- Make sure that the cord for the cord reel is undamaged. Check the continuity of the cord. Disconnect the cord reel from the crane harness and bypass the harness connection. If the crane operates properly, replace cord reel.

Problem: Cylinder drifts outward or downward.**Solutions:**

- Check to see if there is air in the hydraulic system. Operate all cylinders connected to the hydraulic system. Start with the extension cylinder, then operate the main boom, winch, rotation, and ending with the hydraulic outriggers, if installed. When operating, extend each cylinder halfway out, retract all the way in, and then extend until the cylinder rod is at the end of its stroke. Operate cylinders slowly so air is pushed thru the system to the reservoir. Repeat this cycle 2-3 times.
- Make sure the holding valves are operating properly. Remove, clean, and then inspect each holding valve. When removing a holding valve, always relieve the pressure inside the cylinder by loosening jam nut of the holding valve and turning set screw inward/clockwise. Count the number of turns until the set screw is seated. When reinstalling the holding valve, make sure the valve is reset by turning the set screw the number of turns it took to relieve the pressure. Finish by tightening the jam nut.
- Check the cylinder rod for scratches. If a scratch is located on the cylinder rod, hydraulic fluid can pass thru and cause a loss of pressure. Replace cylinder rod or cylinder.
- Check to see if the piston seals are damaged. If they show signs of damage, install a new cylinder seal kit.

6 Function Hetric Radio Remote Troubleshooting

If the system does not operate after normal start-up, follow the recommended troubleshooting sequence to help isolate the cause and determine corrective action.

Transmitter

- Is the E-Stop pushbutton pulled out?
- Are all the switches in their center (neutral) position.
- Are the batteries in the transmitter fully charged?
- Is the transmitter inside its operating range?

Receiver

- Is the antenna plug securely connected?
- If there is an external antenna, is the antenna connection assembly outside the enclosure secure?
- Are the power supply and ground wires securely fastened?
- Are the signal wires separated from the power supply wires?

PROBLEM	PROBABLE CAUSE	CORRECTION
System will not operate after normal start-up procedure.	E-Stop switch engaged	Pull out E-Stop switch.
	Batteries fully discharged	Check batteries to ensure a full charge. Replace with new batteries if necessary.
	No power to the receiver	Check the diagnostic LED on the receiver to be sure power is applied. Ensure that the system is properly grounded.
Transmitter is transmitting (Power LED flashing), but crane will not respond	E-Stop switch engaged	Pull out the E-Stop push button and activated switch on transmitter.
	Transmitter out of range	Take the transmitter back into the range of the receiver.
	Receiver power off	Turn on power to receiver.
	E-Stop failure in transmitter	Check E-Stop pushbutton for damage. Check wiring to contact element for broken or disconnected wires. Repair or replace E-Stop push button or wiring.
All crane motions operate intermittently	Receiver antenna is loose or missing	Tighten or replace antenna.
	External antenna (if used) has loose connection, poor grounding or interference	Tighten antenna and ground connection.
	Ground wiring is poor. Conductor is too small, or receiver is grounded to chassis.	Ground wiring must be connected to machine power source ground. Minimum diameter of conductor ground is 12 AWG.
Some crane motions operate intermittently	Crane motion wiring may be loose.	Check wiring from receiver to plug and from plug to crane motion actuator.

Transmitter Troubleshooting

Notice: When testing the transmitter, the receiver may become active resulting in system operation. Always assume the system is working and will respond when testing a transmitter.

Status LED Troubleshooting

LED Indication	Possible Cause
LED is off	Transmitter is off
LED flashes	Transmitter is operating in a normal mode
LED will not light when any button is pushed, or LED remains on continuously	Replace batteries. If this does not correct the problem, the transmitter must be returned for repair.

Transmitter Repairs

Notice: The transmitter electronic components are exposed when the back of the case is removed. Take caution to prevent dirt or other contaminants from entering the case. Do not allow the circuit to be scraped or damaged in any way.

Receiver Troubleshooting

The following steps should be followed when troubleshooting the receiver.

1. Check the LED indicator. If it is not lit:
 - a. Make sure 12 VDC and ground is present at the connecting wires.
 - b. If using the AC power, check for AC power on the connecting wires.
 - c. If input power is present and the LED is off, check the fuse inside the receiver case.
 - d. If input power is present and the LED is off, and the fuse inside the receiver case is OK, contact Customer Service at Stellar Industries.
2. Activate the transmitter by pressing any command switch.
 - a. If the receiver LED does not flash, test the transmitter.
 - b. Verify the identity code is the same for the transmitter and receiver. use the learn button to re-program the receiver for the transmitter.
 - c. Contact Customer Service at Stellar Industries.
3. Only some functions are operating:
 - a. Check to make sure the common wires for the relays are connected properly. (See Installation drawings for details.
 - b. Check output voltage of the respective wires and the electrical circuits.
 - c. Check the fuses inside the receiver case.
 - d. Check the receiver label to verify the function has been programmed to the needs of the equipment.
4. You are experiencing intermittent operation:
 - a. Check antenna connections and antenna location.
 - b. On AC systems, ensure noise suppression devices have been placed across the coils of all contacts.
 - c. Ensure you are inside the operating range of the receiver and have line of sight to the receiver antenna.
5. Operating Range is short:
 - a. Check all antenna connections and transmitter operation.
 - b. On new installations, verify the receiver antenna is placed properly. If necessary, use an antenna mounting kit to relocate the antenna to a more favorable location.

Receiver Testing

LED Indication	Receiver Action
LED on continuous	Receiver operating voltage is present, no signal is being received.
LED flashes	Signal is being received that matches the decoders address.
LED goes off	Signal is being received, but address is wrong.

4 & 7 Function Hetric Radio Remote Troubleshooting

Problem:

Transmitter will not communicate with the Receiver.

(Note: Make sure the PTO is fully engaged when troubleshooting the problem.)

1. Is the main power switch on? (Control panel located inside the cab.)
2. Is the emergency brake engaged?
3. Is the transmitter battery fully charged? (Note: When the battery is fully charged, there should be a quick beep sound from the transmitter when toggling a function. A longer or constant steady beep indicates that the battery charge is weak or going dead.)
4. Is the E-Stop switch button pulled out or engaged?

Check the receiver functions.

(Note: Remove the receiver cover located on the crane mast)

With the main power on, check the following functions:

1. Is the yellow light flashing in the upper left hand corner of the receiver?

- a. Yes –
 - i. Check the signal functions using the transmitter toggle functions - go to step 2.
- b. No –
 - i. Check the 7.5 fuse located inside the receiver. Replace the fuse if it has blown.
 - ii. If the 7.5 fuse is ok, check the crane power fuse. (Usually located under the chassis hood near the 300 amp continuous duty solenoid.)

2. Does the green light in the upper left hand corner of the receiver flash when operating a toggle switch on the transmitter?

- a. Yes –
 - i. Go to step 3.
- b. No –
 - i. Carefully remove the switch face plate housing from the transmitter and check the following areas:
 1. Check to see if a jumper spade, from the CS458 TX-RF module, is loose or laying inside the transmitter, either laying on, or beneath the coder board.
 2. Check for broken wires on the CS458 TX-RF Module. (Blue, Red, and White with blue stripes - Three wires total.
 3. Check to make sure that the E-Stop 2 Wire connector plug (Located in the upper right hand corner of the coder board) isn't loose or disconnected. (Usually a grey and white with brown stripe wire.)
 4. Check for loose, corroded, or broken wires on the toggle switches. Note: If the green light inside the receiver flashed constantly without engaging a toggle switch, the coder board has failed or a toggle switch may be weak or broken.

3. Are the red LED function lights coming on when activating a toggle on the transmitter?

- a. Yes –
 - i. Go to Step 4.
- b. No –
 - i. The E-Stop switch or coder board has failed.

4. All lights are working properly?

- a. Note: Radio system is functioning correctly - check the following areas:
 - i. Check for loose ground wires.
 - ii. Check for loose or broken wires on the crane valve bank wiring harness.
 - iii. Check to make sure the flow control valve on the valve bank is actuating properly, using the trigger assembly of the transmitter.
 - iv. Check the anti-2-blocking electrical circuit (Limit switch, cord reel, and pressure switch - if applicable) for proper operation.
- b. If problem cannot be determined, contact customer service at Stellar Industries.



Limited Warranty Statement

Stellar Industries, Inc. (Stellar) warrants products designed and manufactured by Stellar to be free from defects in material and workmanship under proper use and maintenance. Products must be installed and operated in accordance with Stellar's written instructions and capacities. The warranty period shall cover the following:

Twelve (12) month warranty on parts,
Twelve (12) month repair labor, and
Thirty-six (36) month warranty on all Stellar Crane and Hooklift structural parts.

The warranty period shall begin from the date recorded by Stellar as the in-service date. This date will be derived from the completed warranty registration card. In the event a warranty registration card is not received by Stellar, the factory ship date will be used. Regardless of in-service date, warranty coverage does not extend beyond twenty-four (24) months from date of manufacture.

Stellar's obligation under this warranty is limited to, and the sole remedy for any such defect shall be, the repair and/or replacement (at Stellar's option) of the unaltered part and/or component in question. Stellar after-sales service personnel must be notified by telephone, fax, or letter of any warranty-applicable damage within fourteen (14) days of its occurrence. If at all possible, Stellar will ship the replacement part within 24-hours of notification by the most economical, yet expedient, means possible. Expedited freight delivery will be at the expense of the owner.

Warranty claims must be submitted and shall be processed in accordance with Stellar's established warranty claim procedure. Stellar after-sales service personnel must be contacted prior to any warranty claim. A return materials authorization (RMA) account number must be issued to the claiming party prior to the return of any warranty parts. Parts returned without prior authorization will not be recognized for warranty consideration. All damaged parts must be returned to Stellar freight prepaid; freight collect returns will be refused. Freight reimbursement of returned parts will be considered as part of the warranty claim.

Warranty service will be performed by any Stellar new equipment distributor, or by any Stellar-recognized service center authorized to service the type of product involved, or by the Stellar factory in the event of a direct sale. At the time of requesting warranty service, the owner must present evidence of date of delivery of the product. The owner shall be obligated to pay for any overtime labor requested of the servicing company by the owner, any field service call charges, and any towing and/or transportation charges associated with moving the equipment to the designated repair/service provider.

All obligations of Stellar and its authorized dealers and service providers shall be voided if someone other than an authorized Stellar dealer provides other than routine maintenance service without prior written approval from Stellar. In the case repair work is performed on a Stellar-manufactured product, original Stellar parts must be used to keep the warranty in force. The warranty may also be voided if the product is modified or altered in any way not approved, in writing, by Stellar.

The owner/operator is responsible for furnishing proof of the date of original purchase of the Stellar product in question. Warranty registration is the ultimate responsibility of the owner and may be accomplished by the completion and return of the Stellar product registration card provided with the product. If the owner is not sure of registration, he is encouraged to contact Stellar at the address below to confirm registration of the product in question. This warranty covers only defective material and workmanship. It does not cover depreciation or damage caused by normal wear and tear, accident, mishap, untrained operators, or improper or unintended use. The owner has the obligation of performing routine care and maintenance duties as stated in Stellar's written instructions, recommendations, and specifications. Any damage resulting from owner/operator failure to perform such duties shall void the coverage of this warranty. The owner will pay the cost of labor and supplies associated with routine maintenance.

The only remedies the owner has in connection with the breach or performance of any warranty on the Stellar product specified are those set above. In no event will Stellar, the Stellar distributor/dealer, or any company affiliated with Stellar be liable for business interruptions, costs of delay, or for any special, indirect, incidental, or consequential costs or damages. Such costs may include, but are not limited to, loss of time, loss of revenue, loss of use, wages, salaries, commissions, lodging, meals, towing, hydraulic fluid, or any other incidental cost.

All products purchased by Stellar from outside vendors shall be covered by the warranty offered by that respective manufacturer only. Stellar does not participate in, or obligate itself to, any such warranty.

Stellar reserves the right to make changes in design or improvement upon its products without imposing upon itself the same upon its products theretofore manufactured.

This warranty will apply to all Stellar Hooklifts, Stellar Tire Service Trucks, & Truck-mounted Cranes shipped from Stellar's factory after July 1, 2005. The warranty is for the use of the original owner only and is not transferable without prior written permission from Stellar.

THIS WARRANTY IS EXPRESSLY IN LIEU OF ANY OTHER WARRANTIES, EXPRESS OR IMPLIED, INCLUDING ANY WARRANTY OF MERCHANTABILITY OR FITNESS FOR A PARTICULAR PURPOSE. REMEDIES UNDER THIS WARRANTY ARE LIMITED TO THE PROVISION OF MATERIAL AND SERVICES, AS SPECIFIED HEREIN. STELLAR INDUSTRIES, INC. IS NOT RESPONSIBLE FOR INCIDENTAL OR CONSEQUENTIAL DAMAGES.

Revision Date: March 2006

Document Number: 37040



Limited Warranty Statement

Stellar Industries, Inc. (Stellar) warrants products designed and manufactured by Stellar to be free from defects in material and workmanship under proper use and maintenance. Products must be installed and operated in accordance with Stellar's written instructions and capacities. The warranty period shall cover the following:

Twelve (12) month warranty on parts,
Twelve (12) month repair labor, and
Thirty-six (36) month warranty on all Stellar Crane and Hooklift structural parts.

The warranty period shall begin from the date recorded by Stellar as the in-service date. This date will be derived from the completed warranty registration card. In the event a warranty registration card is not received by Stellar, the factory ship date will be used. Regardless of in-service date, warranty coverage does not extend beyond twenty-four (24) months from date of manufacture.

Stellar's obligation under this warranty is limited to, and the sole remedy for any such defect shall be, the repair and/or replacement (at Stellar's option) of the unaltered part and/or component in question. Stellar after-sales service personnel must be notified by telephone, fax, or letter of any warranty-applicable damage within fourteen (14) days of its occurrence. If at all possible, Stellar will ship the replacement part within 24-hours of notification by the most economical, yet expedient, means possible. Expedited freight delivery will be at the expense of the owner.

Warranty claims must be submitted and shall be processed in accordance with Stellar's established warranty claim procedure. Stellar after-sales service personnel must be contacted prior to any warranty claim. A return materials authorization (RMA) account number must be issued to the claiming party prior to the return of any warranty parts. Parts returned without prior authorization will not be recognized for warranty consideration. All damaged parts must be returned to Stellar freight prepaid; freight collect returns will be refused. Freight reimbursement of returned parts will be considered as part of the warranty claim.

Warranty service will be performed by any Stellar new equipment distributor, or by any Stellar-recognized service center authorized to service the type of product involved, or by the Stellar factory in the event of a direct sale. At the time of requesting warranty service, the owner must present evidence of date of delivery of the product. The owner shall be obligated to pay for any overtime labor requested of the servicing company by the owner, any field service call charges, and any towing and/or transportation charges associated with moving the equipment to the designated repair/service provider.

All obligations of Stellar and its authorized dealers and service providers shall be voided if someone other than an authorized Stellar dealer provides other than routine maintenance service without prior written approval from Stellar. In the case repair work is performed on a Stellar-manufactured product, original Stellar parts must be used to keep the warranty in force. The warranty may also be voided if the product is modified or altered in any way not approved, in writing, by Stellar.

The owner/operator is responsible for furnishing proof of the date of original purchase of the Stellar product in question. Warranty registration is the ultimate responsibility of the owner and may be accomplished by the completion and return of the Stellar product registration card provided with the product. If the owner is not sure of registration, he is encouraged to contact Stellar at the address below to confirm registration of the product in question. This warranty covers only defective material and workmanship. It does not cover depreciation or damage caused by normal wear and tear, accident, mishap, untrained operators, or improper or unintended use. The owner has the obligation of performing routine care and maintenance duties as stated in Stellar's written instructions, recommendations, and specifications. Any damage resulting from owner/operator failure to perform such duties shall void the coverage of this warranty. The owner will pay the cost of labor and supplies associated with routine maintenance.

The only remedies the owner has in connection with the breach or performance of any warranty on the Stellar product specified are those set above. In no event will Stellar, the Stellar distributor/dealer, or any company affiliated with Stellar be liable for business interruptions, costs of delay, or for any special, indirect, incidental, or consequential costs or damages. Such costs may include, but are not limited to, loss of time, loss of revenue, loss of use, wages, salaries, commissions, lodging, meals, towing, hydraulic fluid, or any other incidental cost.

All products purchased by Stellar from outside vendors shall be covered by the warranty offered by that respective manufacturer only. Stellar does not participate in, or obligate itself to, any such warranty.

Stellar reserves the right to make changes in design or improvement upon its products without imposing upon itself the same upon its products theretofore manufactured.

This warranty will apply to all Stellar Hooklifts, Stellar Service Trucks, & Truck-mounted Cranes shipped from Stellar's factory after July 1, 2005. The warranty is for the use of the original owner only and is not transferable without prior written permission from Stellar.

THIS WARRANTY IS EXPRESSLY IN LIEU OF ANY OTHER WARRANTIES, EXPRESS OR IMPLIED, INCLUDING ANY WARRANTY OF MERCHANTABILITY OR FITNESS FOR A PARTICULAR PURPOSE. REMEDIES UNDER THIS WARRANTY ARE LIMITED TO THE PROVISION OF MATERIAL AND SERVICES, AS SPECIFIED HEREIN. STELLAR INDUSTRIES, INC. IS NOT RESPONSIBLE FOR INCIDENTAL OR CONSEQUENTIAL DAMAGES.

Revision Date: March 2006

Document Number: 37040