

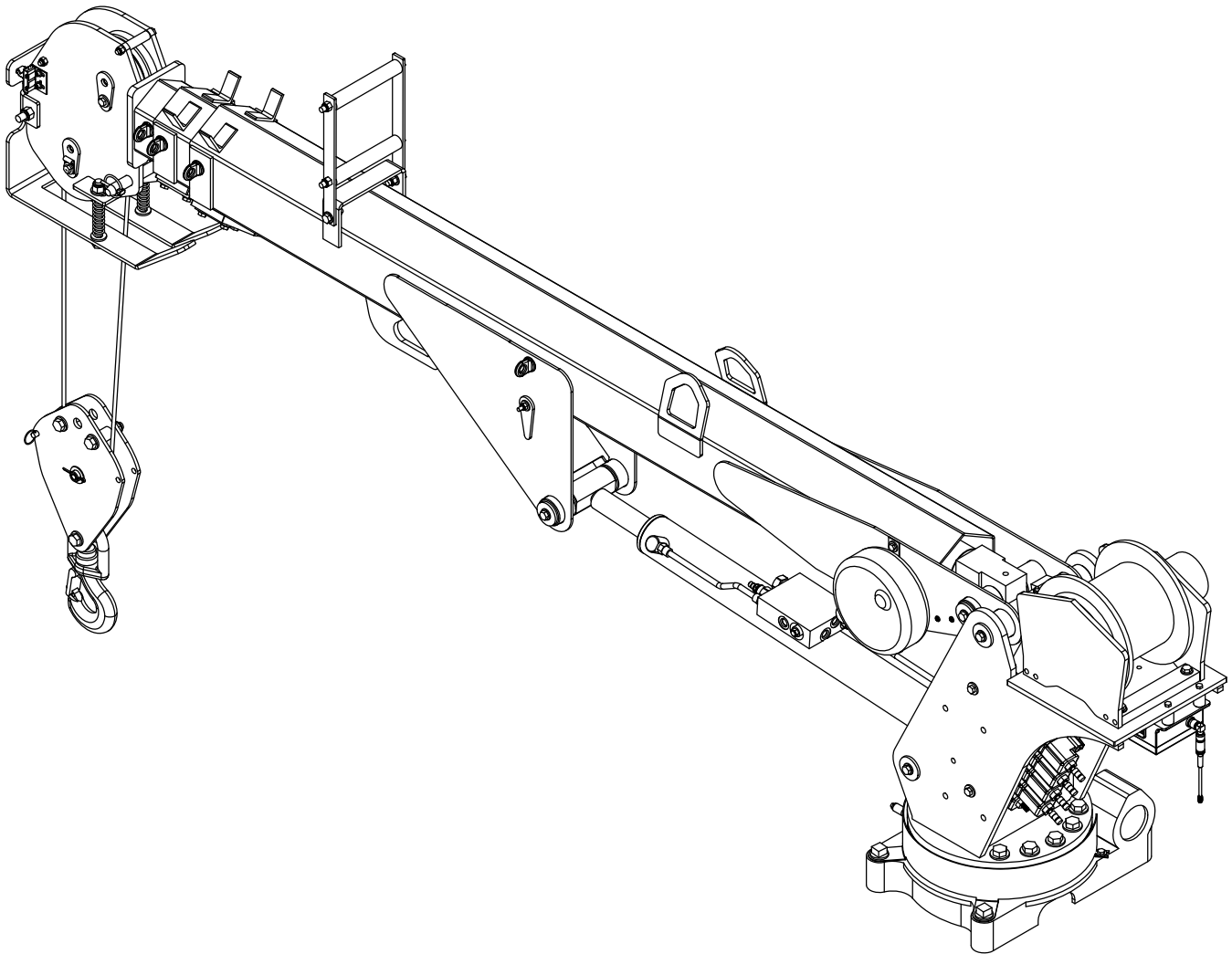

# Model 3315 Telescopic Crane Owner's Manual

Installation • Assembly Drawings • Parts



**Notice:** A copy of this manual must remain with the equipment at all times.  
For a printable download copy, please visit: [www.stellarindustries.com](http://www.stellarindustries.com)

**Stellar Industries, Inc.**

**190 State Street**

**PO Box 169**

**Garner, IA 50438**

**800-321-3741**

**Fax: 641-923-2811**

**[www.stellarindustries.com](http://www.stellarindustries.com)**

Subject to Change without Notification.  
© 2018 Stellar Industries, Inc.

Rev 1  
PN 89643

# Model 3315 Manual Revisions

Date of Revision	Section Revised	Description of Revision

**Serial Tag  
Location**

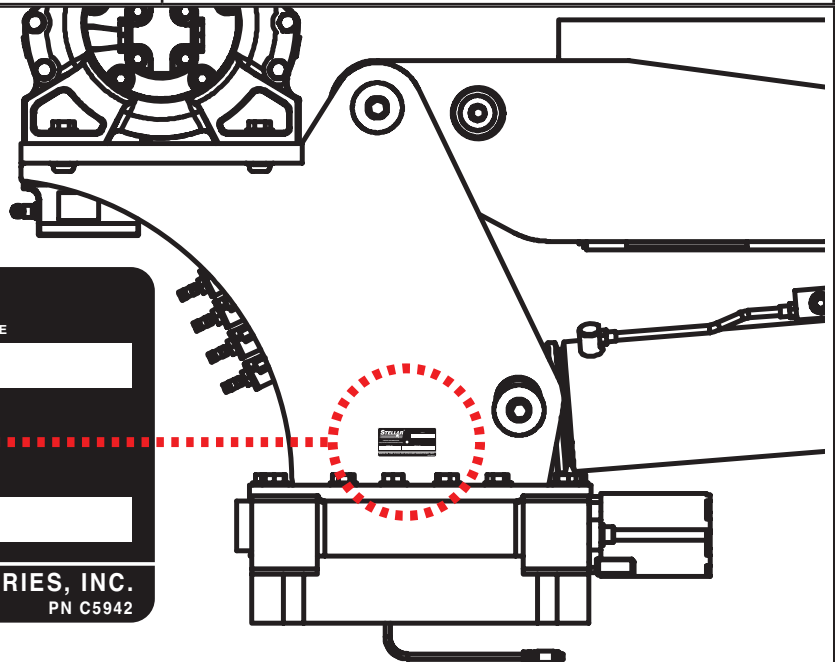
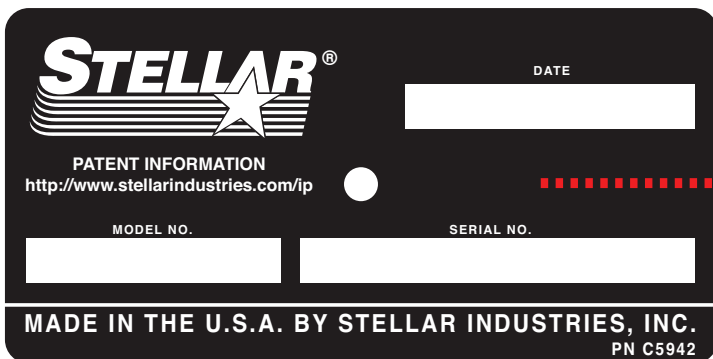

# Table of Contents

---

Introduction .....	iv
<b>Chapter 1 - Specifications .....</b>	<b>1</b>
Model 3315 Specifications .....	1
Capacity Chart - Decal PN 70304 .....	2
Dimensional Drawing 1 .....	3
Dimensional Drawing 2 .....	4
<b>Chapter 2 - Installation .....</b>	<b>5</b>
General Installation .....	5
Installer Notice .....	5
Torque Data Chart .....	6
Installation Overview .....	7
Control Kit (12V CDT Non-Boost) - PN 69983 .....	8
Control Kit (Cradle CDT Non-Boost) - PN 69985 .....	9
Control Kit (V2 Cradle 12V) - PN 70022 .....	10
Control Kit (V2 Cradle) - PN 70023 .....	11
Wiring Diagram (Electrical Version) .....	12
Hydraulic Kit (V2 12V CDT) - PN 70005 .....	13
Hydraulic Kit - PN 70006 .....	14
Hydraulic Kit - PN 70018 .....	15
Hydraulic Kit - PN 70019 .....	16
Valve Bank - PN 50591 .....	17
Valve Bank - PN 72666 .....	18
Hydraulic Installation .....	19
Hydraulic System .....	20
Face Seal/O-Ring Size Chart .....	21
Stability Procedure .....	22
Crane Load Level Indicator .....	23
Decal Placement - PN 70303 .....	24
<b>Chapter 3 - Assembly Drawings .....</b>	<b>25</b>
Base Assembly - PN 19998 .....	25
Gear Bearing - PN 16653 .....	26
Mast Assembly (CDT Version) - PN 69785 .....	27
Mast Assembly (Non-CDT Version) - PN 70072 .....	28
Power Unit Assembly (Electric Version Only) - PN 57939 .....	29
Main Boom Assembly (CDT Version) - PN 69786 .....	30
Main Boom Assembly (Non-CDT Version) - PN 70080 .....	31
Extension Boom Assembly - PN 69787 .....	32
Extension Boom Assembly (1 Hyd/1 Manual) - PN 69902 .....	33
Main Cylinder Assembly - PN 70081 .....	34
Extension Cylinder Assembly - PN 69817 .....	35
Extension Cylinder Assembly (1 Hyd/1 Manual) - PN 69911 .....	36
Cable & Hook Assembly - PN 69978 .....	37
5-Function Radio Transmitter Assembly - PN 67894 .....	38
<b>Chapter 4 - Replacement Parts .....</b>	<b>39</b>

# Introduction

A copy of this manual is provided with every crane and can be found in the hard plastic manual case that is installed on the chassis. A copy of this manual shall remain with the crane at all times.

Throughout the manual, three signal words will be used to bring attention to important items:

## **NOTICE**

A NOTICE signal word indicates a practice not related to physical injury.

## **⚠ WARNING**

A WARNING signal word indicates a hazardous situation which, if not avoided, could result in death or serious injury.

## **⚠ DANGER**

A DANGER signal word indicates a hazardous situation which, if not avoided, will result in death or serious injury.

Information contained within this manual does not cover operation, maintenance, or troubleshooting. Please refer to the General Light Duty Crane Manual for details on these items.

This manual is not binding. Stellar Industries, Inc. reserves the right to change, at any time, any or all of the items, components, and parts deemed necessary for product improvement or commercial/production purposes. This right is kept with no requirement or obligation for immediate mandatory updating of this manual.

In closing:

If more information is required or technical assistance is needed, or if you feel that any part of this manual is unclear or incorrect, please contact the Stellar Customer Service Department by phone at 800-321-3741 or email at [service@stellarindustries.com](mailto:service@stellarindustries.com).

**For Technical Questions, Information, Parts, or Warranty, Call Toll-Free at  
800-321-3741**

Hours: Monday - Friday, 8:00 a.m. - 5:00 p.m. CST

Or email at the following addresses:

**Technical Questions, and Information**

[service@stellarindustries.com](mailto:service@stellarindustries.com)

**Order Parts**

[parts@stellarindustries.com](mailto:parts@stellarindustries.com)

**Warranty Information**

[warranty@stellarindustries.com](mailto:warranty@stellarindustries.com)

# Chapter 1 - Specifications

## Model 3315 Specifications

Crane Rating*:	11,500 ft-lb (1.59 TM)	
Standard Boom Length:	7' 0" (2.13 m) from CL of Crane	
Boom Extension:	1st Stage: Hydraulic 48" (121.9 cm) 2nd Stage: Manual 48" (121.9 cm) / Optional Hyd.	
Maximum Horizontal Reach:	15' (4.57 m) from CL of Crane	
Maximum Vertical Lift:	17' 8" (5.40 m) from Crane Base	
Stowed Height (Crane Only):	31.2" (79.2 cm)	
Required Mounting Space:	18" x 15" (45.7 x 38.1 cm)	
Approximate Crane Weight:	3315 (Electric)	2H: 940 lbs (426 kg) 1H1M: 860 lbs (390 kg)
	3315 (Hydraulic)	2H: 850 lbs (386 kg) 1H1M: 770 lbs (349 kg)
Controls:	Radio control standard for all functions.	
Wire Rope:	1/4" (0.63 cm) 7X19 GAC X 65' (19.81 m)	
Boom Elevation:	-10° to +80°	
Winch Specifications		
Line Pull Speed:	30 ft/min (9.1 m/min)	
Max. Single Part Line:	1,600 lbs (725 kg)	
Max. Double Part Line:	3,200 lbs (1,450 kg)	
Rotation (Worm Gear):	370° Power	
Lifting Capacity**:	3,200 lbs @ 3'7" (1451 kg @ 1.10 m)	
	765 lbs @ 15' (345 kg @ 4.6 m)	
Power Supply:	12V Power Unit:	2 gpm @ 2,600 psi (7.6 lpm @ 179 bar)
	PTO & Pump:	3 gpm @ 2,600 psi (11.4 lpm @ 179 bar)

\*Subject to change without notification.

\*\*Subject to change without notification.

# Capacity Chart - Decal PN 70304

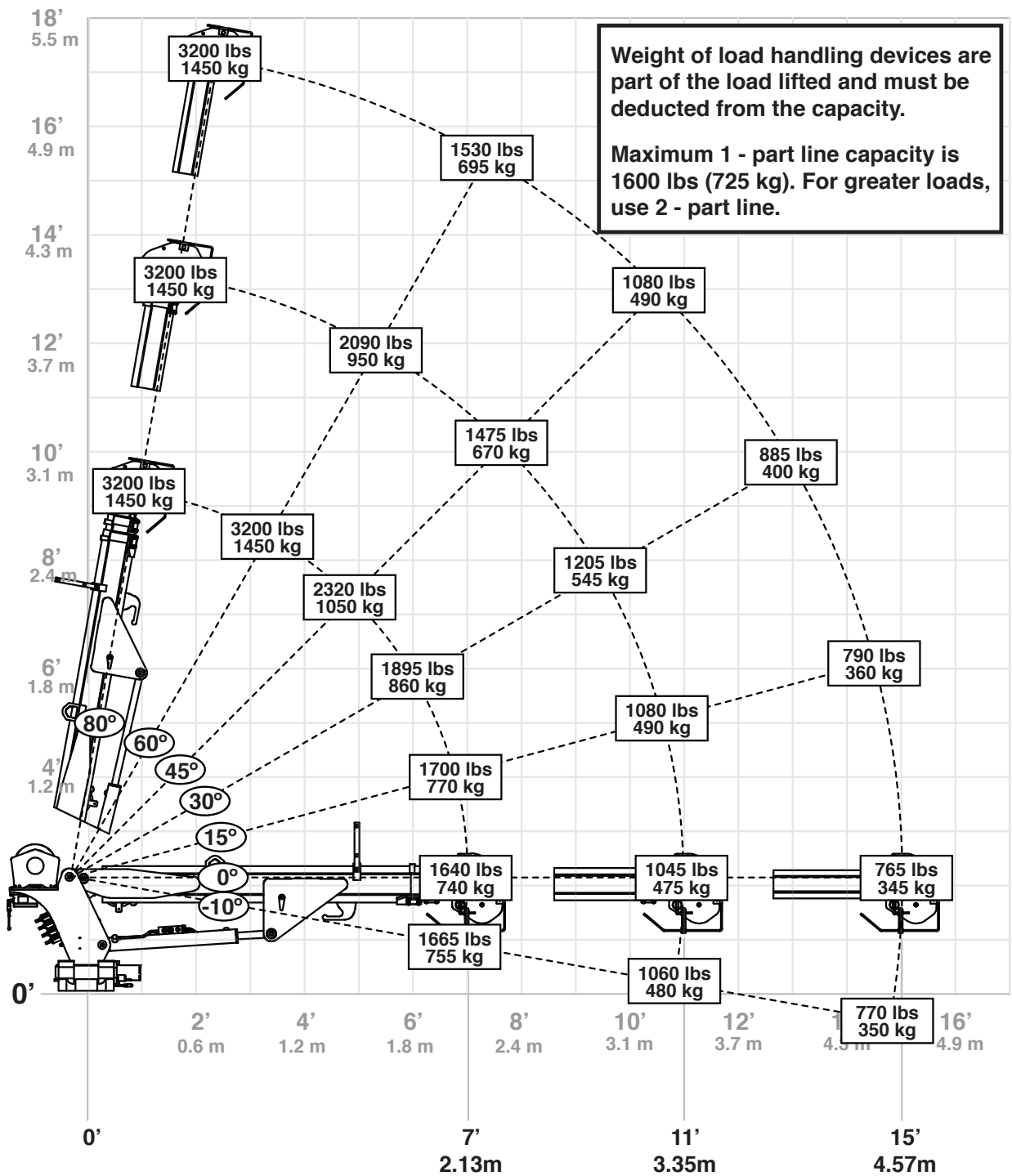

# 3315

PN 70304 - Rev A

# Dimensional Drawing 1

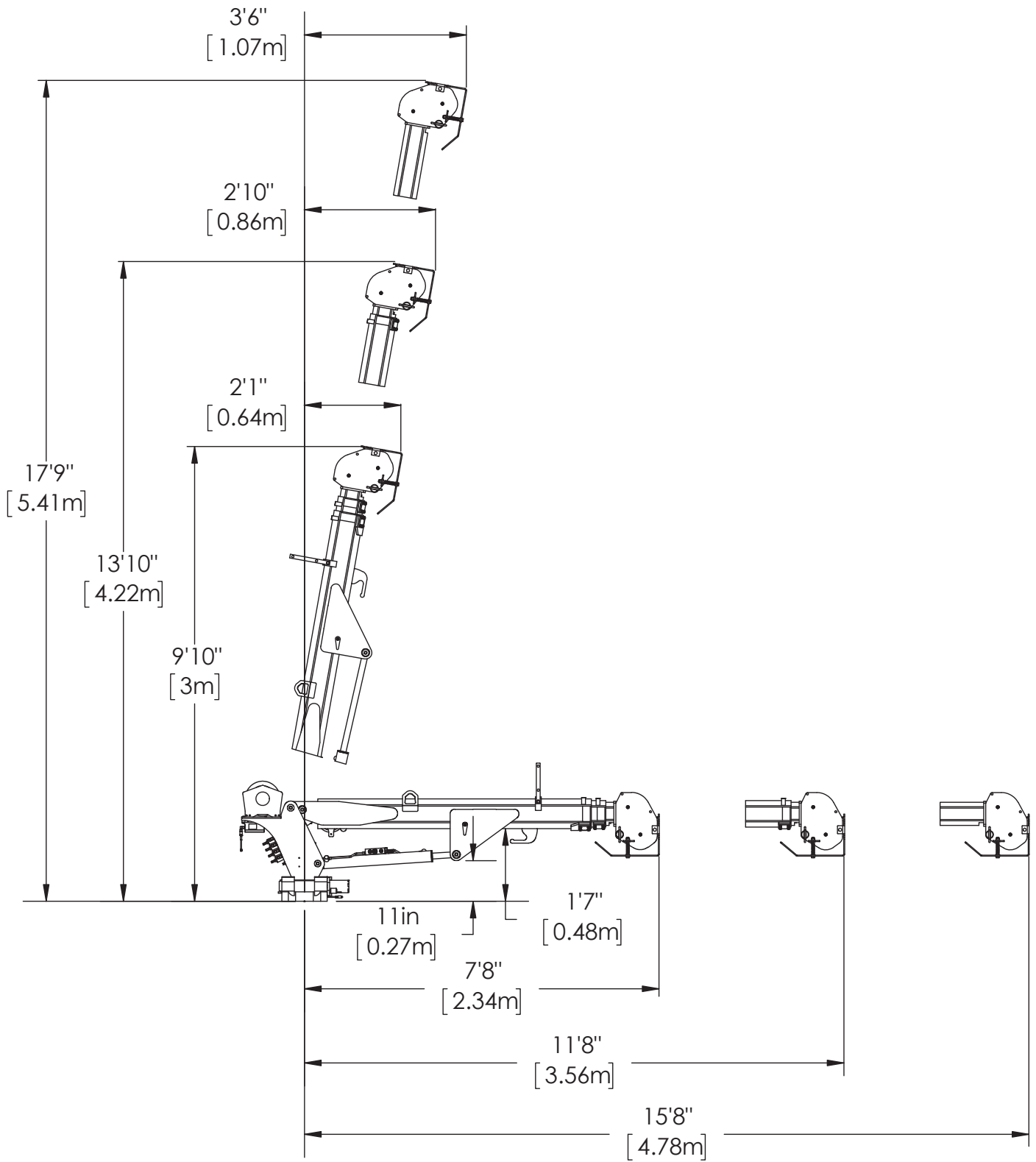

# Dimensional Drawing 2

$\phi 47.20\text{in}$   
 [3.93ft]  
 12V

$\phi 34.63\text{in}$   
 [2.89ft]  
 HYD

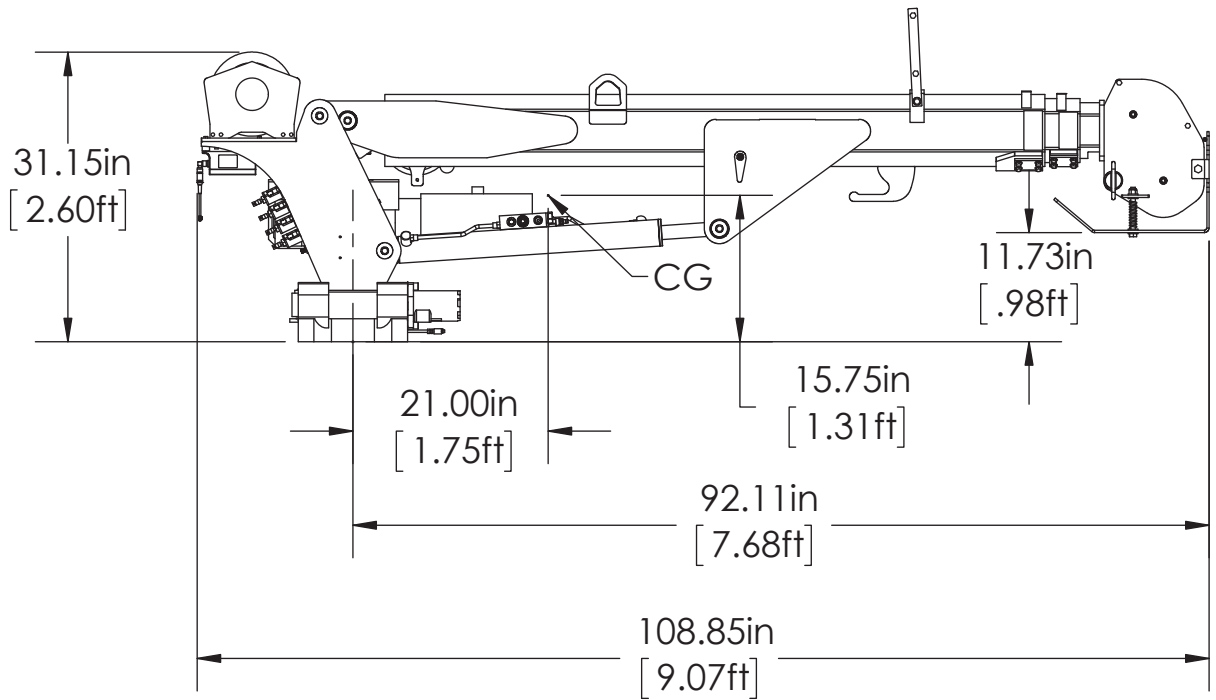
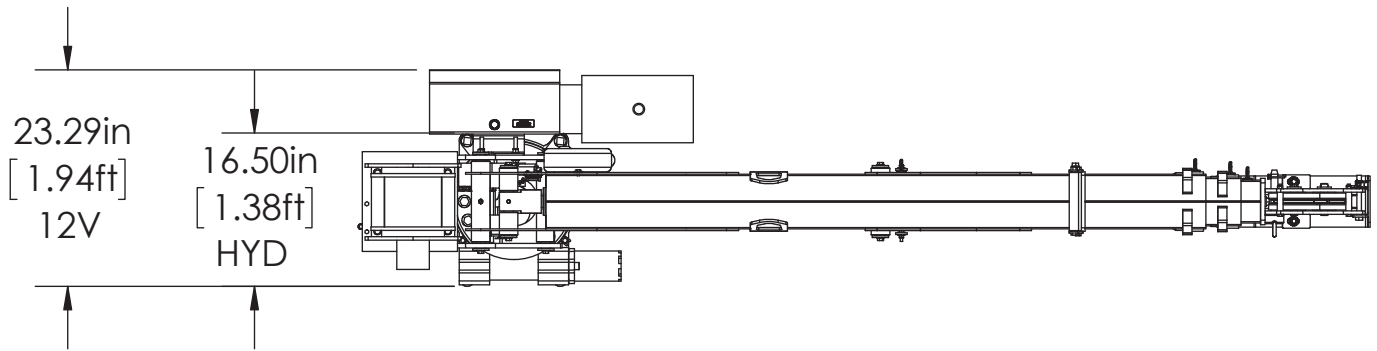
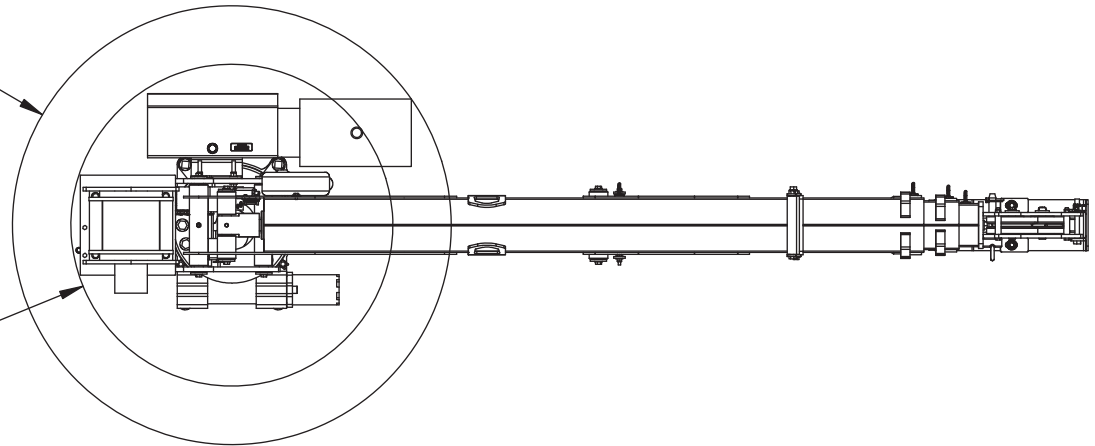



# Chapter 2 - Installation

## General Installation

This chapter is designed to serve as a general guide for the installation of a Stellar 3315 Crane on a Stellar Service Body. Each installation is considered unique so certain portions of this chapter may or may not apply to your direct application. If a question should arise during the installation process, please contact Stellar Customer Service at (800) 321 3741.

This crane is designed for use with a Stellar Service Body installed on a vehicle that meets the minimum chassis requirements of the crane. It is the installer's responsibility to assure that the crane is mounted on a platform that will support the maximum crane rating of this crane.

**⚠ WARNING** Do not install this crane on a body not capable of handling the loads imposed on it. Failure to do so may result in serious injury or death.

**NOTICE** When installing welder units to the service bodies, it is highly recommended that a surge protector is installed on the chassis batteries to protect the crane radio receiver, wiring and other electronic devices from an unexpected electrical spike or surge. Failure to do so could result in extensive damage to the service body and crane electrical circuit.

## Installer Notice

According to Federal Law (49 cfr part 571), each final-stage manufacturer shall complete the vehicle in such a manner that it conforms to the standards in effect on the date of manufacture of the incomplete vehicle, the date of final completion, or a date between those two dates. This requirement shall, however, be superseded by any conflicting provisions of a standard that applies by its terms to vehicles manufactured in two or more stages.

Therefore, the installer of Stellar® Cranes and Bodies is considered one of the manufacturers of the vehicle. As such a manufacturer, the installer is responsible for compliance with all applicable federal and state regulations. They are required to certify that the vehicle is in compliance with the Federal Motor Vehicle Safety Standards and other regulations issued under the National Traffic and Motor Vehicle Safety Act.

Please reference the Code of Federal Regulations, title 49 - Transportation, Volume 5 (400-999), for further information, or visit <http://www.gpoaccess.gov/nara/index.html> for the full text of Code of Federal Regulations.

## Torque Data Chart

When using the torque data in the chart, the following rules should be observed:

- Bolt manufacturer's particular specifications should be consulted when provided.

- Flat washers of equal strength must be used.

- All torque measurements are given in foot-pounds. To convert to inch-pounds, multiply by 12.

- Torque values specified are for bolts with residual oils or no special lubricants applied. If special lubricants of high stress ability, such as Never-Seez compound graphite and oil, molybdenum disulphite, colloidal copper or white lead are applied, multiply the torque values in the charts by the factor .90. The use of Loctite does not affect the torque values listed above.

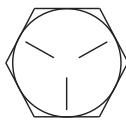
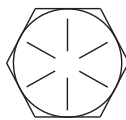
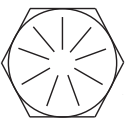
		GRADE 5		GRADE 8		GRADE 9
						
Size (DIA-TPI)	Bolt DIA (Inches)	Plain (Ft-Lb)	Plated (Ft-Lb)	Plain (Ft-Lb)	Plated (Ft-Lb)	Plated (Ft-Lb)
5/16-18	0.3125	17	13	25	18	22
3/8-16	0.3750	31	23	44	33	39
7/16-14	0.4375	49	37	70	52	63
1/2-13	0.5000	75	57	105	80	96
9/16-12	0.5625	110	82	155	115	139
5/8-11	0.6250	150	115	220	160	192
3/4-10	0.7500	265	200	375	280	340
7/8-9	0.8750	395	295	605	455	549
1-8	1.000	590	445	910	680	823
1 1/8-7	1.1250	795	595	1290	965	1167
1 1/4-7	1.2500	1120	840	1815	1360	1646
1 3/8-6	1.3750	1470	1100	2380	1780	2158
1 1/2-6	1.500	1950	1460	3160	2370	2865

- Torque values for socket-head capscrews are the same as for Grade 8 capscrews.
- Do not use these values if a different torque value or tightening procedure is given for a specific application. Torque values listed are for general use only. Check tightness of fasteners periodically.
- Shear bolts are designed to fail under predetermined loads. Always replace shear bolts with identical grade.
- Fasteners should be replaced with the same or higher grade. If higher grade fasteners are used, these should only be tightened to the strength of the original.
- Tighten plastic insert or crimped steel-type lock nuts to approximately 110 percent of the dry torque values shown in the chart below, applied to the nut, not to the bolt head. Tighten toothed or serrated-type lock nuts to the full torque value. *Note: "Lubricated" means coated with a lubricant such as engine oil, or fasteners with phosphate and oil coatings. "Dry" means plain or zinc plated without lubrication. Tighten lubricated bolts to approximately 80% of dry bolts.*

## Installation Overview

1. Determine that the mounting location for the 3315 is at least 18" x 15" (45.7 x 38.1 cm).
2. Use the detail below to drill .938" diameter holes into the mounting plate. Run tap on the threads of the base to be sure they are clean.
3. Use a crane or lifting device capable of lifting the weight of the Stellar® Crane. The 3315 crane weighs approximately 900 lbs (407 kg) to 1,025 lbs (465 kg) - See specs page for your specific model. **Note: Cranes are shipped with rotation positioned at 180 degrees from normal stowed travel position (See photo above).** This will allow for easy installation of the crane and permanent connection of all hydraulic and electrical components prior to repositioning into the crane saddle.
4. Connect straps or chain from the lifting device to the lifting rings on the 3315.
5. Use four (4) 7/8 x 2 1/4 #8 bolts and four (4) #8 flat washers.
6. Install a washer on each bolt.
7. Apply Loctite Thread locker #277 to the bolts.
8. Using the lifting device, lower the 3315 just above the crane compartment and start the bolts. Have someone assist in leveling the crane. **Note: the rotation motor should be to the door side of crane compartment and the boom should be extended back over the rear bumper.**
9. Secure the crane using the mounting hardware provided. **Note: longer or shorter cap screws may be required – recommended thread engagement into crane base is 1.00" – use grade 8, zinc plated cap screws only.**
10. **Torque the cap screws to 454 ft-lbs.**
11. Remove supporting crane.
12. Hook-up hydraulics and electrical using the schematics provided in this chapter.

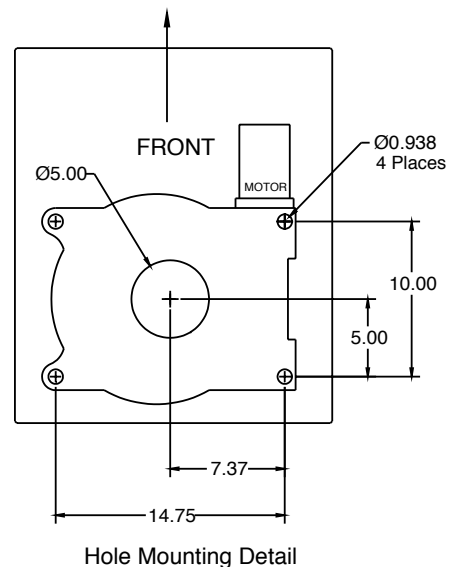
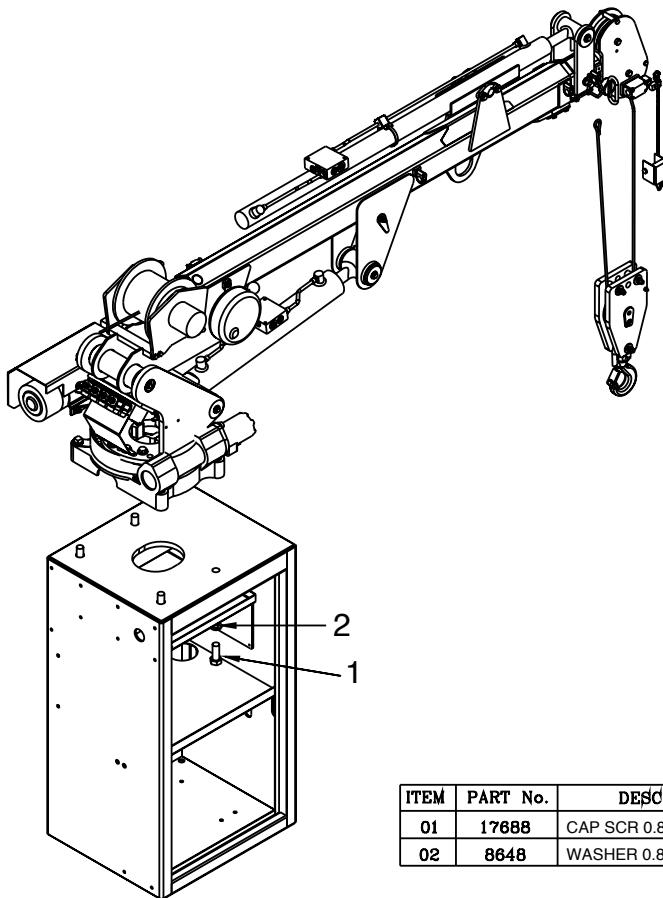

ITEM	PART No.	DESCRIPTION	QTY
01	17688	CAP SCR 0.88-9x2.25 HHGR8	4
02	8648	WASHER 0.88 SAE GR8	4

# Control Kit (12V CDT Non-Boost) - PN 69983

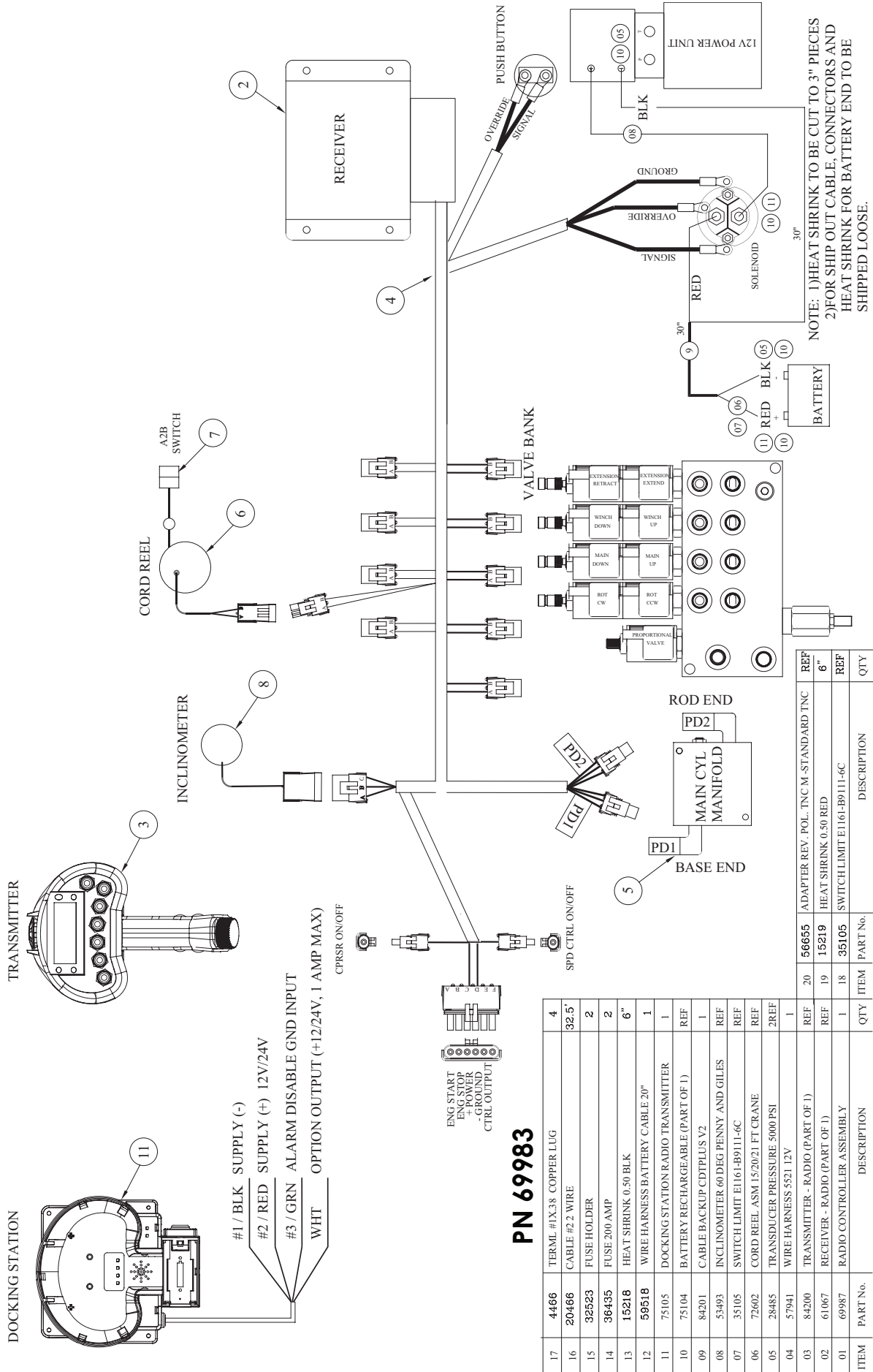

# Control Kit (Cradle CDT Non-Boost) - PN 69985

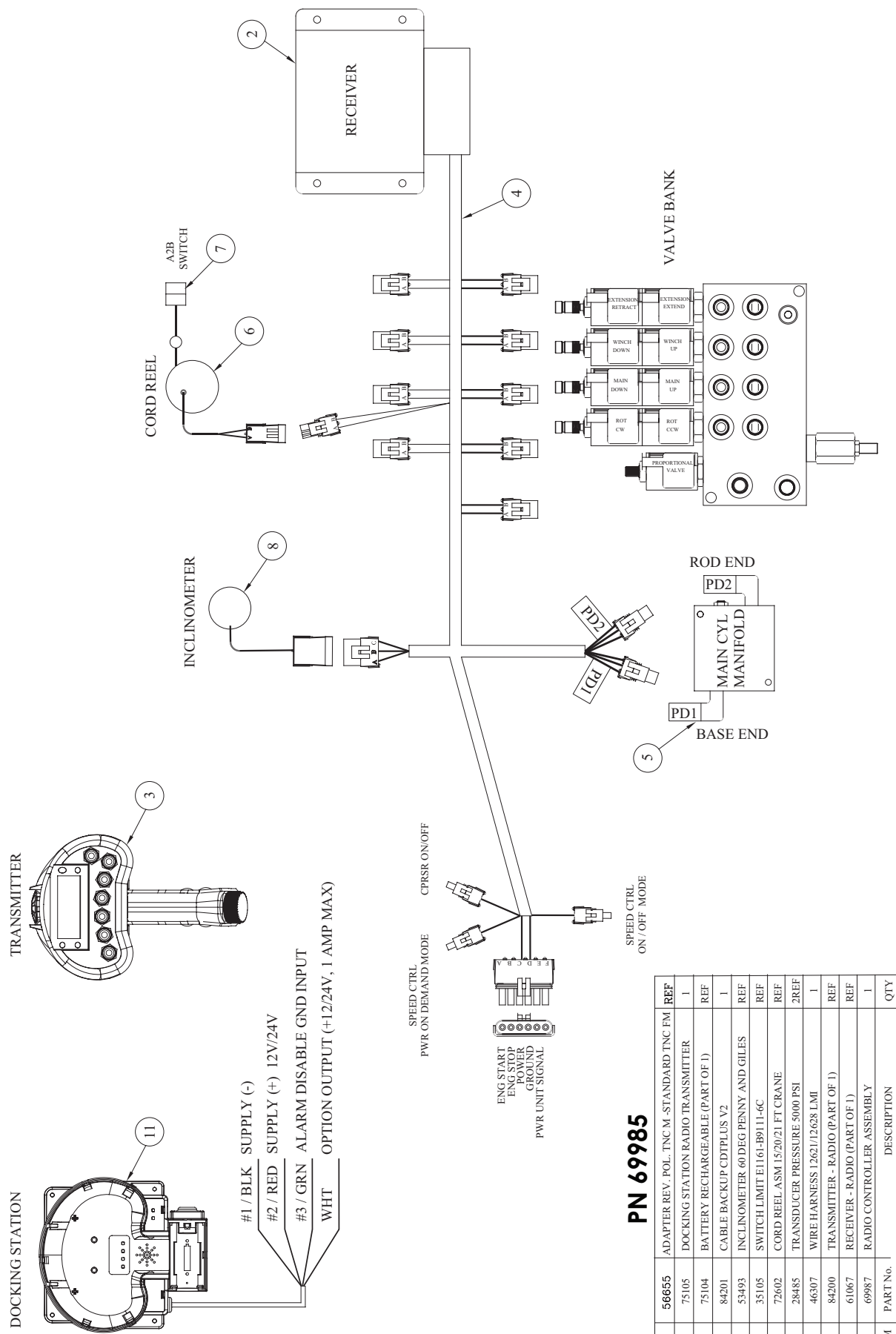

## PN 69985

ITEM	PART No.	DESCRIPTION	QTY
12	56655	ADAPTER REV. POL. TNC M-STANDARD TNC FM	REF
11	75105	DOCKING STATION RADIO TRANSMITTER	1
10	75104	BATTERY RECHARGEABLE (PART OF 1)	REF
09	84201	CABLE BACKUP CDTPLUS V2	1
08	53493	INCLINOMETER 60 DEG PENNY AND GILES	REF
07	35105	SWITCH LIMIT E1161-B9111-6C	REF
06	72602	CORD REEL ASM 15/20/21 FT CRANE	2REF
05	28485	TRANSducer PRESSURE 5000 PSI	REF
04	46307	WIRE HARNESS 12621/12628 LMI	1
03	84200	TRANSMITTER - RADIO (PART OF 1)	REF
02	61067	RECEIVER - RADIO (PART OF 1)	REF
01	69987	RADIO CONTROLLER ASSEMBLY	1

# Control Kit (V2 Cradle 12V) - PN 70022

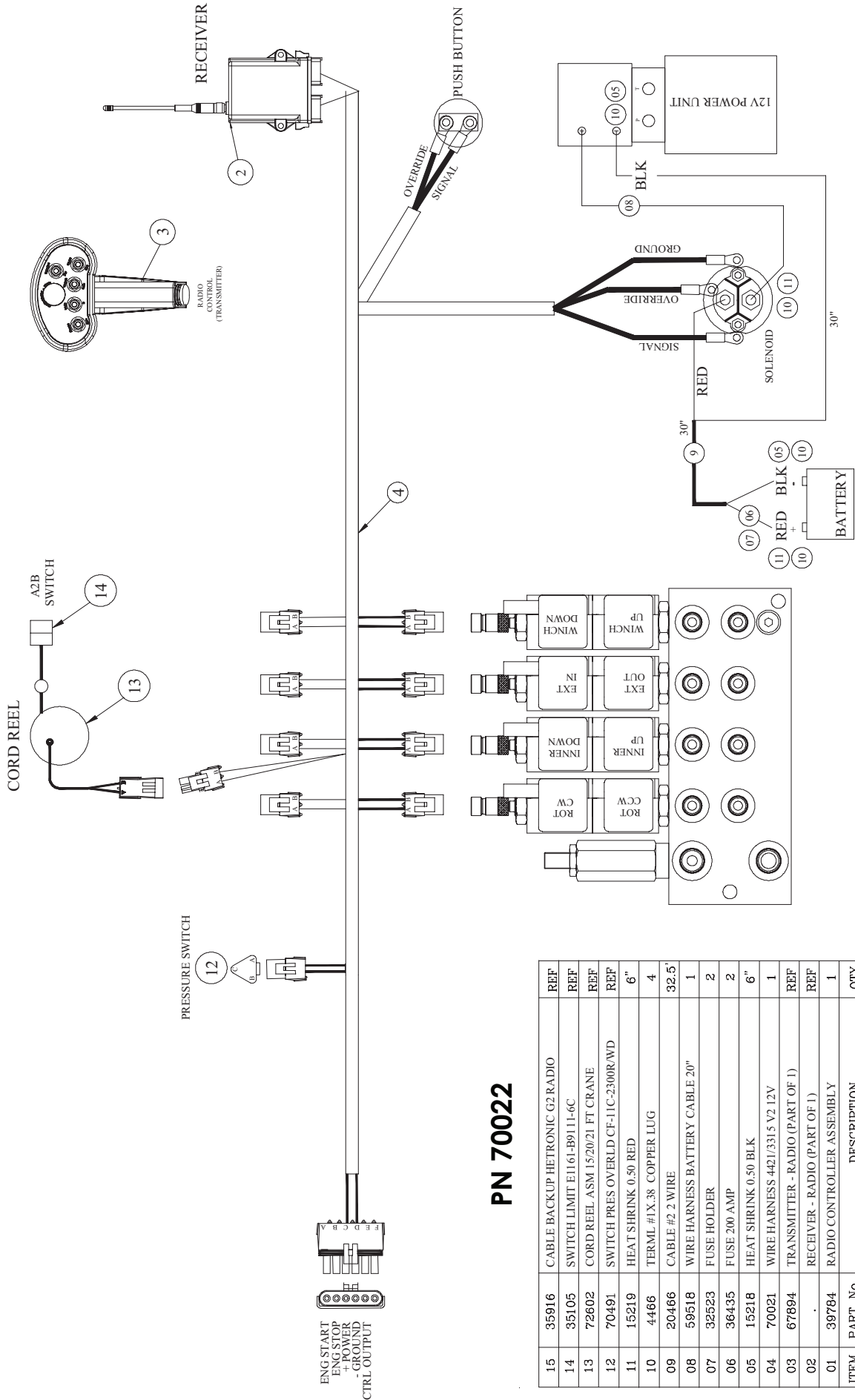

## PN 70022

ITEM	PART No.	DESCRIPTION	QTY
15	35916	CABLE BACKUP HETRONIC G2 RADIO	REF
14	35105	SWITCH LIMIT E1161-B9111-6C	REF
13	72602	CORD REEL ASM 15/20/21 FT CRANE	REF
12	70491	SWITCH PRES OVERLD CF-11C-2300R/WD	REF
11	15219	HEAT SHRINK 0.50 RED	6"
10	4466	TERML #1X.38 COPPER LUG	4
09	20466	CABLE #2 2 WIRE	32.5'
08	59518	WIRE HARNESS BATTERY CABLE 20"	1
07	32523	FUSE HOLDER	2
06	36435	FUSE 200 AMP	2
05	15218	HEAT SHRINK 0.50 BLK	6"
04	70021	WIRE HARNESS 4421/331.5 V2 12V	1
03	67894	TRANSMITTER - RADIO (PART OF 1)	REF
02	.	RECEIVER - RADIO (PART OF 1)	REF
01	39784	RADIO CONTROLLER ASSEMBLY	1
ITEM	PART No.	DESCRIPTION	QTY

NOTE:

1. HEAT SHRINK TO BE CUT TO 3" PIECES
2. FOR SHIP OUT CABLE, CONNECTORS AND HEAT SHRINK FOR BATTERY END TO BE SHIPPED LOOSE.

# Control Kit (V2 Cradle) - PN 70023

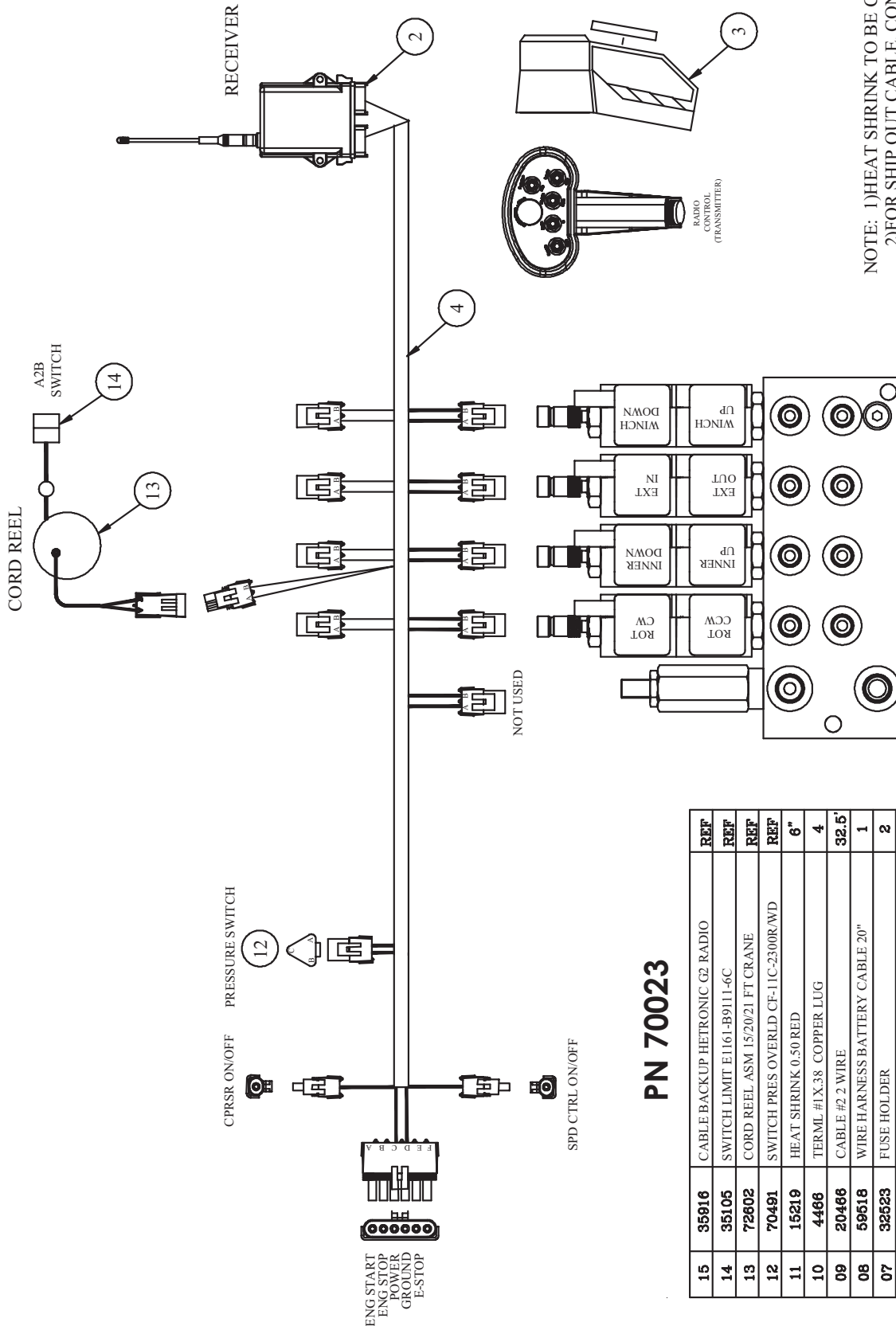

## PN 70023

ITEM	PART No.	DESCRIPTION	QTY
15	35916	CABLE BACKUP HETRONIC G2 RADIO	REF
14	35105	SWITCH LIMIT E1161-B9111-6C	REF
13	72602	CORD REEL ASM 15/20/21 FT CRANE	REF
12	70491	SWITCH PRES OVERLD CF-11C-2300R/WD	REF
11	15219	HEAT SHRINK 0.50 RED	6"
10	4466	TERML #1X.38 COPPER LUG	4
09	20466	CABLE #2 WIRE	32.5'
08	59516	WIRE HARNESS BATTERY CABLE 20"	1
07	32523	FUSE HOLDER	2
06	36435	FUSE 200 AMP	2
05	15218	HEAT SHRINK 0.50 BLK	6"
04	44067	WIRE HARNESS 12621/12628	1
03	67894	TRANSMITTER - RADIO (PART OF 1)	REF
02	REF	RECEIVER - RADIO (PART OF 1)	REF
01	39764	RADIO CONTROLLER ASSEMBLY	1

NOTE: 1)HEAT SHRINK TO BE CUT TO 3" PIECES  
2)FOR SHIP OUT CABLE, CONNECTORS AND  
HEAT SHRINK FOR BATTERY END TO BE  
SHIPPED LOOSE.

# Wiring Diagram (Electrical Version)

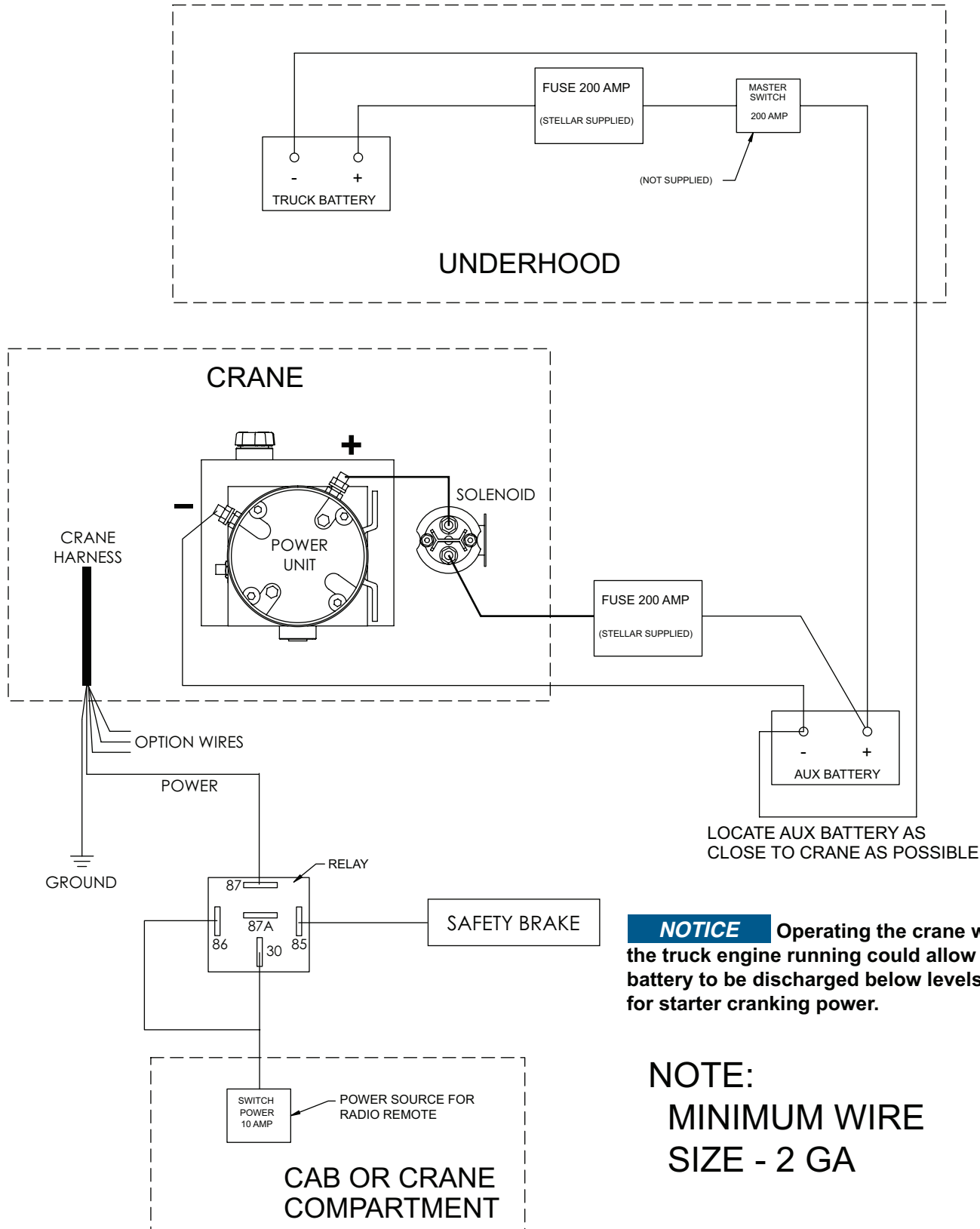

**NOTICE** Operating the crane without the truck engine running could allow the truck battery to be discharged below levels required for starter cranking power.

**NOTE:**  
MINIMUM WIRE  
SIZE - 2 GA



# Hydraulic Kit (V2 12V CDT) - PN 70005

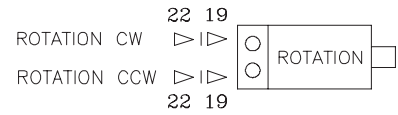
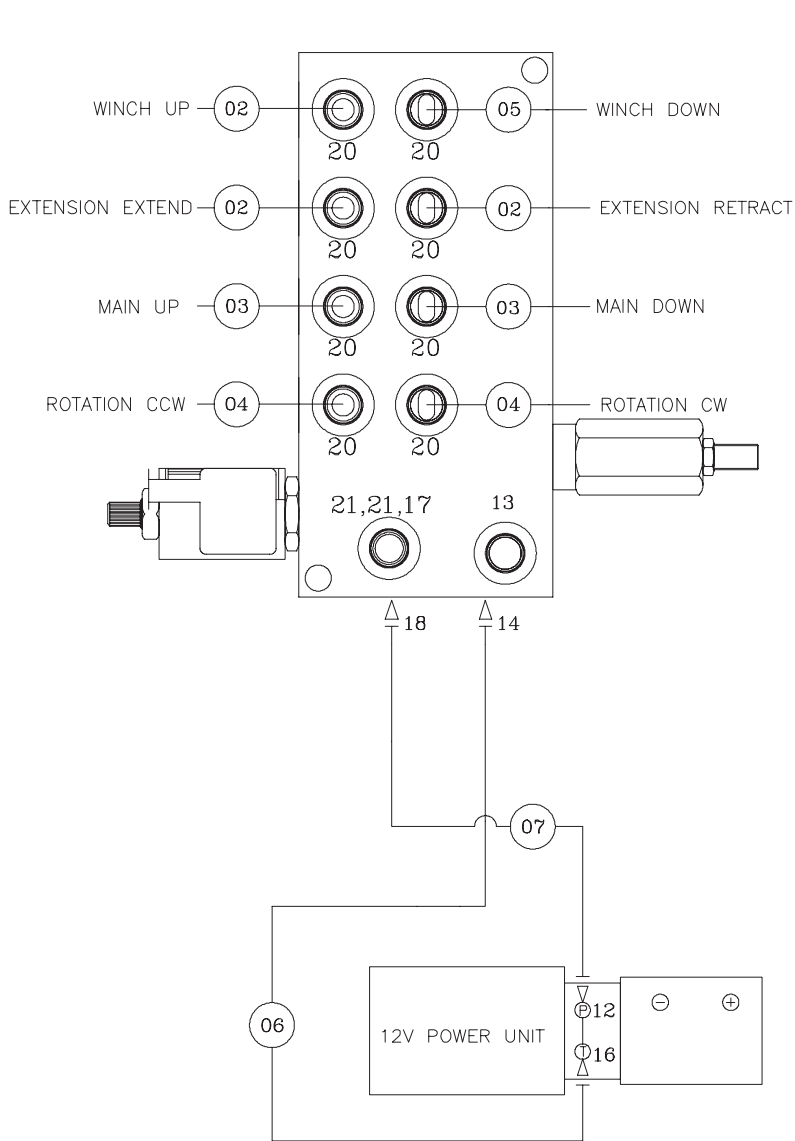

NOTE: USE 32" OF HOSE PROTECTOR P/N 4043 OVER THE ROTATION HOSES

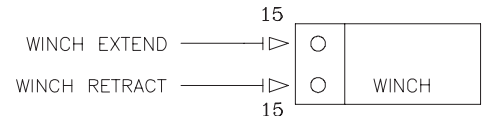
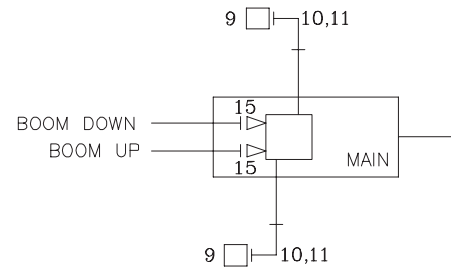
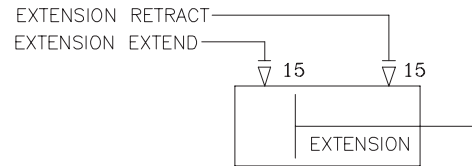

NOTE: USE 12" OF HOSE PROTECTOR P/N 4043 OVER THE 2 WINCH HOSES

## PN 70005

11	3861	FTG 6-6 MAORB-FORB 90	2	22	C1198	FTG 4-4 MFS-MAORB 90	2
10	15111	FTG 6-4 MORB-FORB STRAIGHT REDUCER	2	21	51817	FTG 4-4 MAORB-FORB 90	2
09	28485	TRANSDUCER PRESSURE 5000 PSI	2	20	D1291	FTG 4-4 MFS-MORB STRAIGHT	8
08	4043	HOSE PROTECTOR 0.50 AS-B-17	44"	19	55833	FTG 10-4 MORB-FORB STRAIGHT REDUCER	2
07	13438	HOSE-HYD .25 X 26	1ref	18	D1190	FTG 4-6 MFS-MAORB 45	1
06	70020	HOSE-HYD .38 X 29	1ref	17	39780	GAUGE OIL LF 2.5 0-5000 CBM SAE	1
05	70011	HOSE-HYD .25 X 19	1ref	16	C0338	FTG 6-6 MFS-MAORB 90	1
04	21158	HOSE-HYD .25 X 34	2ref	15	C4922	FTG 4-6 MFS-MORB STRAIGHT	6
03	70010	HOSE-HYD .25 X 22.50	2ref	14	D1193	FTG 6-6 MFS-MAORB 45	1
02	70009	HOSE-HYD .25 X 17	3ref	13	D0511	FTG 4 MORB PLUG HOLLOW HEX	1
01	70007	HOSE KIT 4421/3315 V2 12V (incl:2-7)	1	12	3338	FTG 4-6 MFS-MAORB 90	1
ITEM	PART No.	DESCRIPTION	QTY	ITEM	PART No.	DESCRIPTION	QTY

# Hydraulic Kit - PN 70006

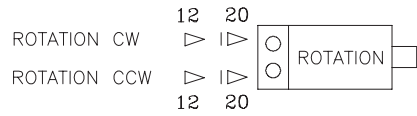
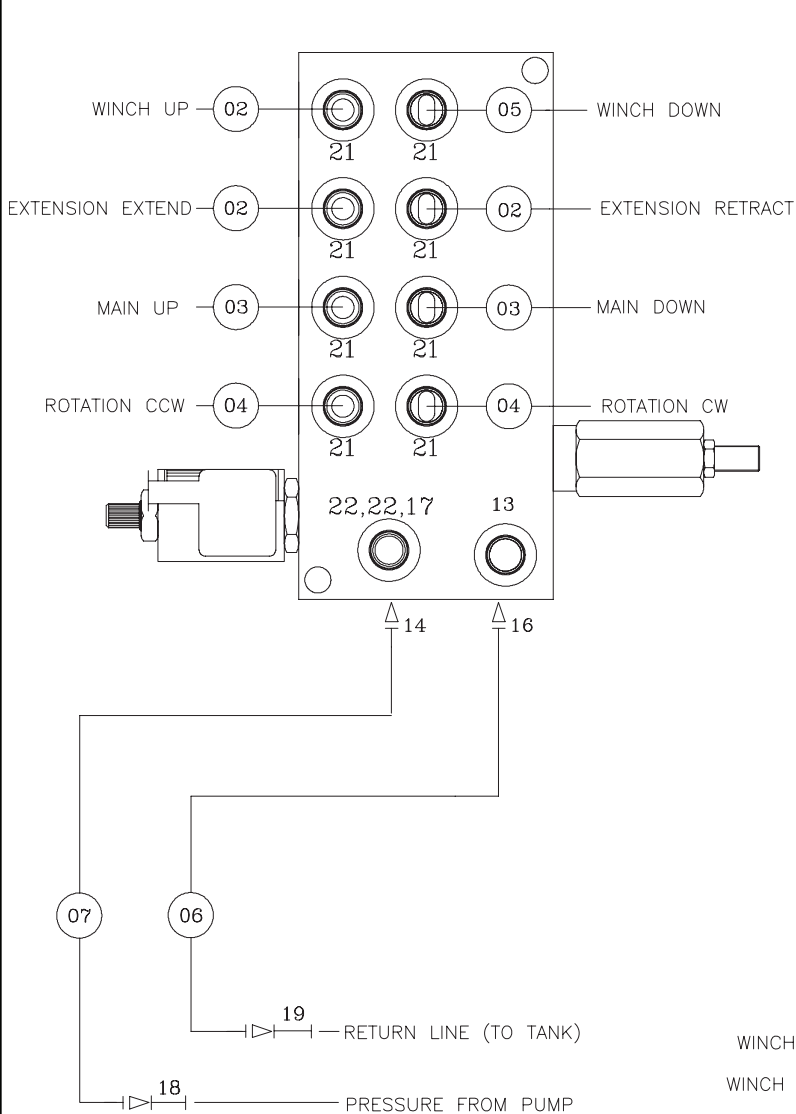

NOTE: USE 32" OF HOSE PROTECTOR P/N 4043 OVER THE ROTATION HOSES

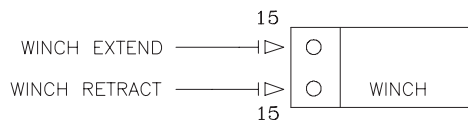
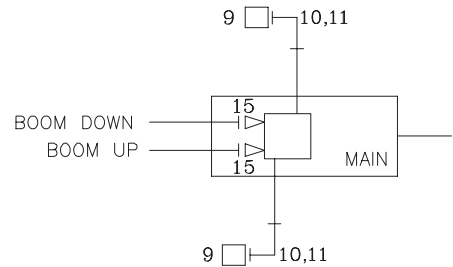
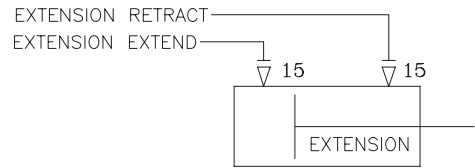

NOTE: USE 12" OF HOSE PROTECTOR P/N 4043 OVER THE 2 WINCH HOSES

## PN 70006

11	3861	FTG 6-6 MAORB-FORB 90	2	22	51817	FTG 4-4 MAORB-FORB 90	2
10	15111	FTG 6-4 MORB-FORB STRAIGHT REDUCER	2	21	D1291	FTG 4-4 MFS-MORB STRAIGHT	8
09	28485	TRANSDUCER PRESSURE 5000 PSI	2	20	55833	FTG 10-4 MORB-FORB STRAIGHT REDUCER	2
08	4043	HOSE PROTECTOR 0.50 AS-B-17	44"	19	12171	FTG 6-6 MFS-MFS SWIVEL STRAIGHT	1
07	70012	HOSE-HYD .25 X 9	1ref	18	32302	FTG 4-4 MFS-MFS SWIVEL STRAIGHT	1
06	70779	HOSE-HYD .38 X 9	1ref	17	39780	GAUGE OIL LF 2.5" 0-5000 CBM	1
05	70011	HOSE-HYD .25 X 19	1ref	16	D1193	FTG 6-6 MFS-MAORB 45	1
04	21158	HOSE-HYD .25 X 34	2ref	15	C4922	FTG 4-6 MFS-MORB STRAIGHT	6
03	70010	HOSE-HYD .25 X 22.50	2ref	14	D1190	FTG 4-6 MFS-MAORB 45	1
02	70009	HOSE-HYD .25 X 17	3ref	13	D0511	FTG 4 MORB PLUG HOLLOW HEX	1
01	70008	HOSE KIT 4421/3315 V2 (incl:2-7)	1	12	C1198	FTG 4-4 MFS-MAORB 90	2
ITEM	PART No.	DESCRIPTION	QTY	ITEM	PART No.	DESCRIPTION	QTY

# Hydraulic Kit - PN 70018

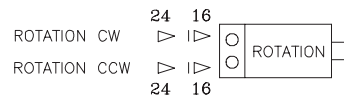
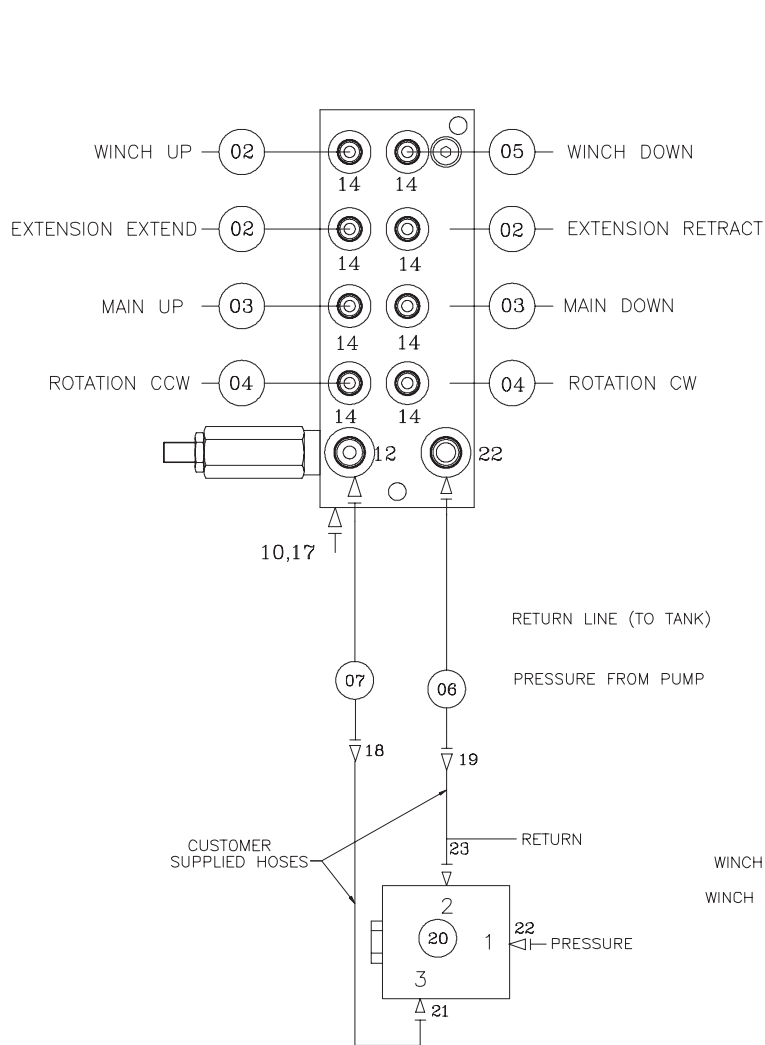

NOTE: USE 32" OF HOSE PROTECTOR P/N 4043 OVER THE ROTATION HOSES

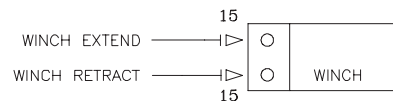
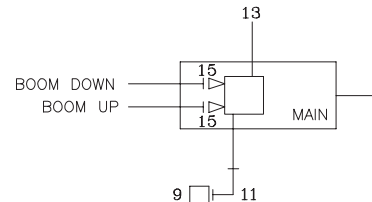
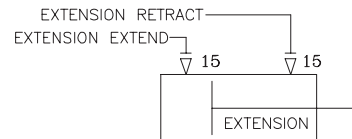

NOTE: USE 12" OF HOSE PROTECTOR P/N 4043 OVER THE 2 WINCH HOSES

## PN 70018

12	3338	FTG 4-6 MFS-MAORB 90	1	24	C1198	FTG 4-4 MFS-MAORB 90	2
11	3861	FTG 6-6 MAORB-FORB 90	1	23	C2345	FTG 6-6-6 MFS-MFS-MAORB TEE	1
10	51817	FTG 4-4 MAORB-FORB 90	1	22	C0338	FTG 6-6 MFS-MAORB 90	2
09	70491	SWITCH PRES OVERLD CD-11C-2300R/WD	1	21	0279	FTG 6-6 MFS-MORB STRAIGHT	1
08	4043	HOSE PROTECTOR 0.50 AS-B-17	44"	20	26196	VALVE FLW CTRL/PR FRCA-XAN-ECI-3GPM	1
07	70012	HOSE-HYD .25 X 9	1ref	19	12171	FTG 6-6 MFS-MFS SWIVEL STRAIGHT	1
06	70779	HOSE-HYD .38 X 9	1ref	18	32302	FTG 4-4 MFS-MFS SWIVEL STRAIGHT	1
05	70011	HOSE-HYD .25 X 19	1ref	17	39780	GAUGE OIL LF 2.5" 0-5000 CBM	1
04	21158	HOSE-HYD .25 X 34	2ref	16	55833	FTG 10-4 MORB-FORB STRAIGHT REDUCER	2
03	70010	HOSE-HYD .25 X 22.50	2ref	15	C4922	FTG 4-6 MFS-MORB STRAIGHT	6
02	70009	HOSE-HYD .25 X 17	3ref	14	D1291	FTG 4-4 MFS-MORB STRAIGHT	8
01	70008	HOSE KIT 4421/3315 V2 (incl:2-7)	1	13	C4961	FTG 6 MORB PLUG HOLLOW HEX	1
ITEM	PART No.	DESCRIPTION	QTY	ITEM	PART No.	DESCRIPTION	QTY

# Hydraulic Kit - PN 70019

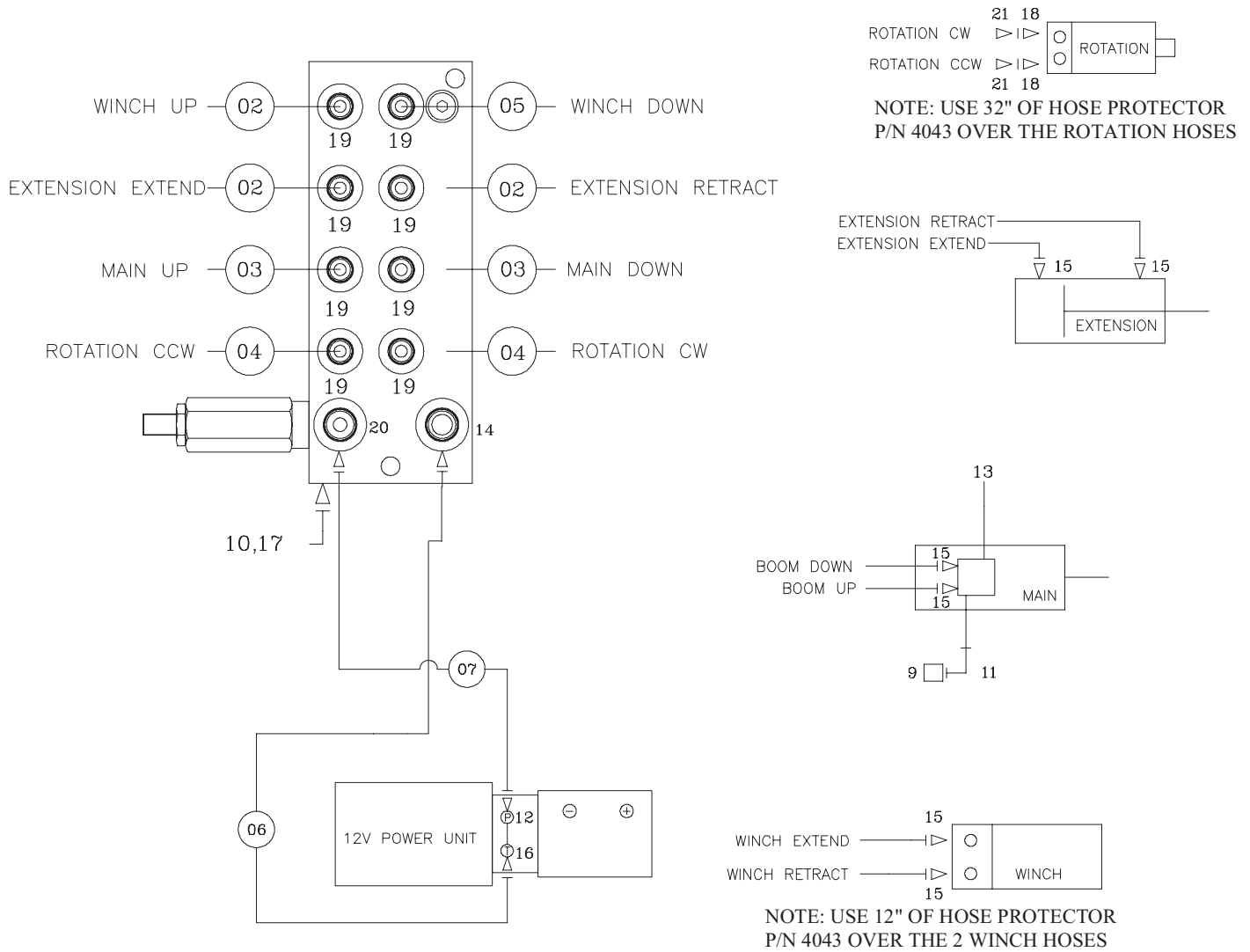

## PN 70019

11	3861	FTG 6-6 MAORB-FORB 90	1				
10	51817	FTG 4-4 MAORB-FORB 90	1	21	C1198	FTG 4-4 MFS-MAORB 90	2
09	70491	SWITCH PRES OVERLD CD-11C-2300R/WD	1	20	D1190	FTG 4-6 MFS-MAORB 45	1
08	4043	HOSE PROTECTOR 0.50 AS-B-17	44"	19	D1291	FTG 4-4 MFS-MORB STRAIGHT	8
07	13438	HOSE-HYD .25 X 26	1ref	18	55833	FTG 10-4 MORB-FORB STRAIGHT REDUCER	2
06	70020	HOSE-HYD .38 X 29	1ref	17	39780	GAUGE OIL LF 2.5 0-5000 CBM SAE	1
05	70011	HOSE-HYD .25 X 19	1ref	16	C0338	FTG 6-6 MFS-MAORB 90	1
04	21158	HOSE-HYD .25 X 34	2ref	15	C4922	FTG 4-6 MFS-MORB STRAIGHT	6
03	70010	HOSE-HYD .25 X 22.50	2ref	14	D1193	FTG 6-6 MFS-MAORB 45	2
02	70009	HOSE-HYD .25 X 17	3ref	13	C4961	FTG 6 MORB PLUG HOLLOW HEX	1
01	70007	HOSE KIT 4421/3315 V2 12V (incl:2-7)	1	12	3338	FTG 4-6 MFS-MAORB 90	1
ITEM	PART No.	DESCRIPTION	QTY	ITEM	PART No.	DESCRIPTION	QTY

# Valve Bank - PN 50591

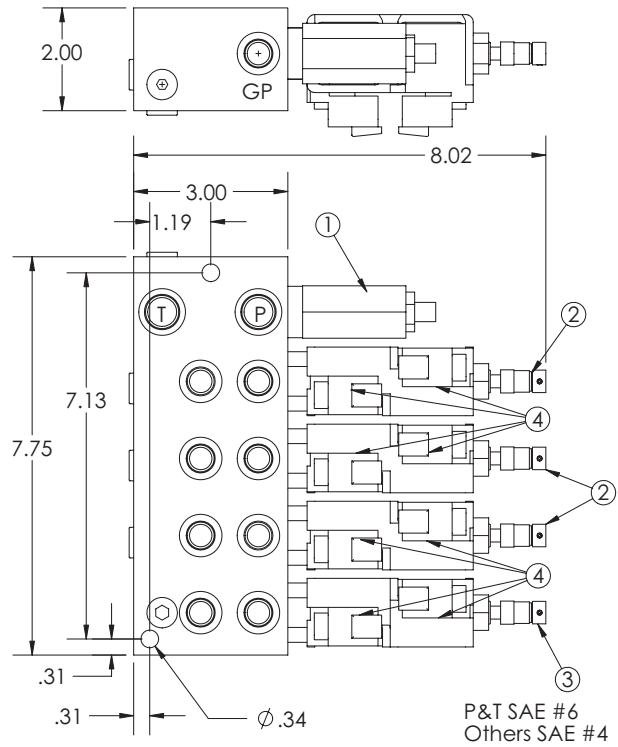
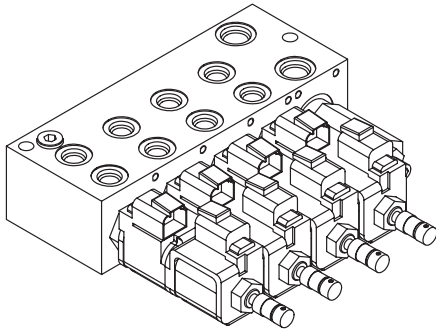

## HYDRAULIC SCHEMATIC

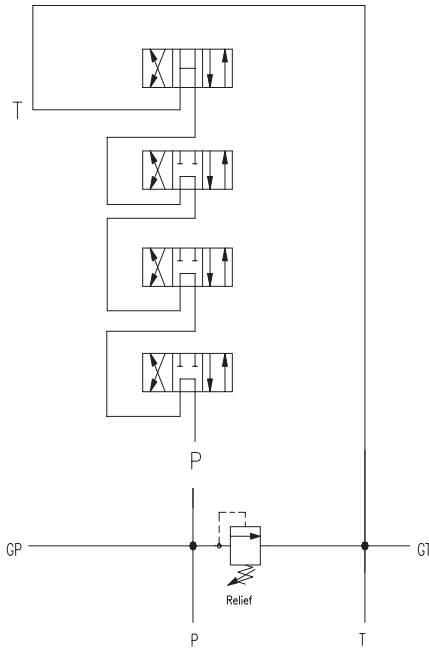

## PN 50591

ITEM	PART	DESCRIPTION	QTY	TORQUE
1	25375	RELIEF VALVE 24957	1	23-27 FT-LBS
	25376	SEAL KIT 25375		
2	25377	VALVE SOLND 3 POS 4 WAY TAND G02571	3	22 FT-LBS
3	25378	VALVE SOLND 3 POS 4 WAY OPEN G02591	1	22 FT-LBS
	25379	SEAL KIT 25377/25378		
4	55126	COIL 12VDC DUETSCH CCP012H	8	3 FT-LBS

# Valve Bank - PN 72666

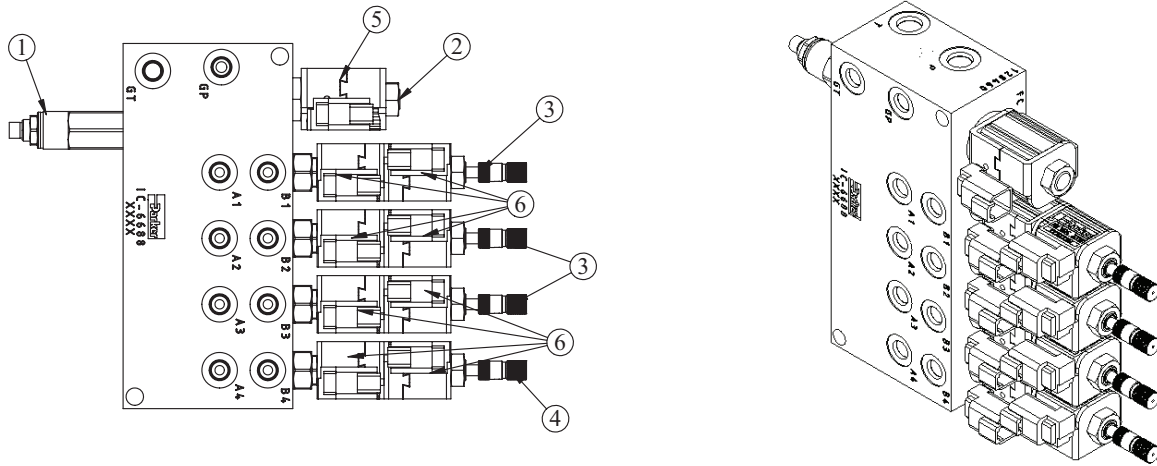

P&T SAE #6  
Others SAE #4

## HYDRAULIC SCHEMATIC

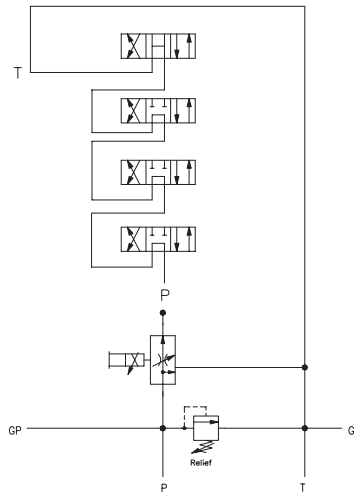

## PN 72666

ITEM	PART	DESCRIPTION	QTY	TORQUE
1	25375	RELIEF VALVE 24957	1	23-27 FT LBS
	25376	SEAL KIT 25375		
2	25381	VALVE FLW CTRL PRP/JP04C3150N 0-4	1	20-22 FT LBS
	25369	SEAL KIT 24960/25381		
3	25377	VALVE SOLND 3 POS 4 WAY TAND G02571	3	22FT LBS
4	25378	VALVE SOLND 3 POS 4 WAY OPEN G02591	1	22 FT LBS
	25379	SEAL KIT 25377/25378		
5	44532	COIL 12VDC DUETSCH CAP012H	1	3 FT LBS
6	55126	COIL 12VDC DUETSCH CCP012H	8	3 FT LBS

# Hydraulic Installation

1. After mounting, locate the pressure and return lines. Note: Pressure line is 1/4" hose; Return line is 3/8" hose. Hoses are terminated using swivel fittings.
2. Install hydraulic lines per diagram below. Note: Stabilizer valve supplies oil to crane using the Power Beyond feature.
3. Install hydraulic reservoir with return filter. Attach pump pressure line to valve, return link to tank.
4. Fill system with hydraulic oil (See Stellar® Lubrication Recommendations for fluid details).

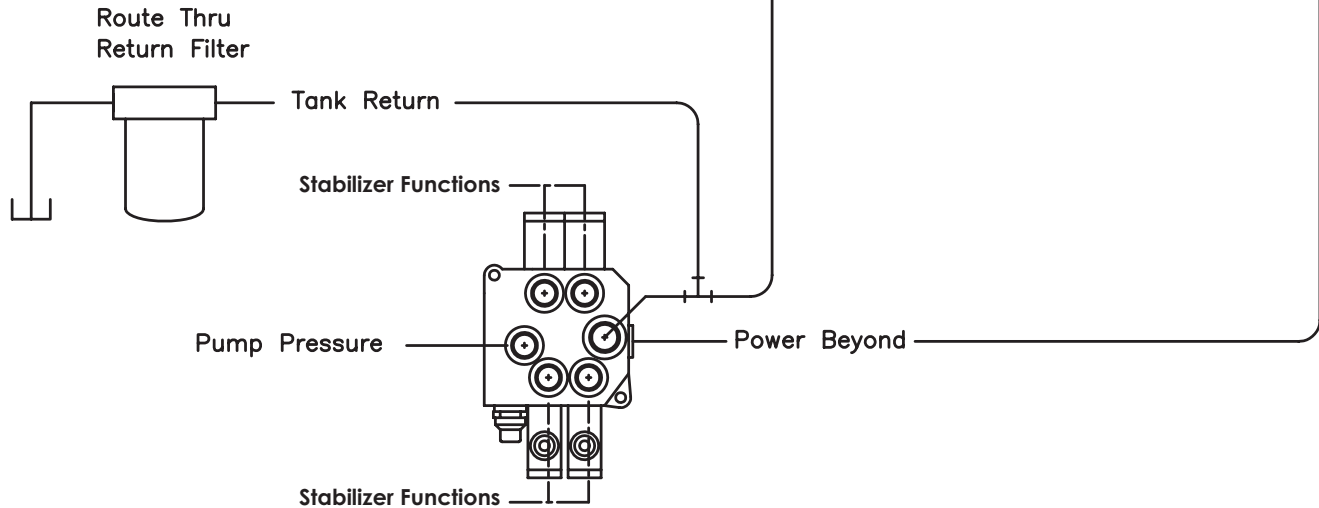
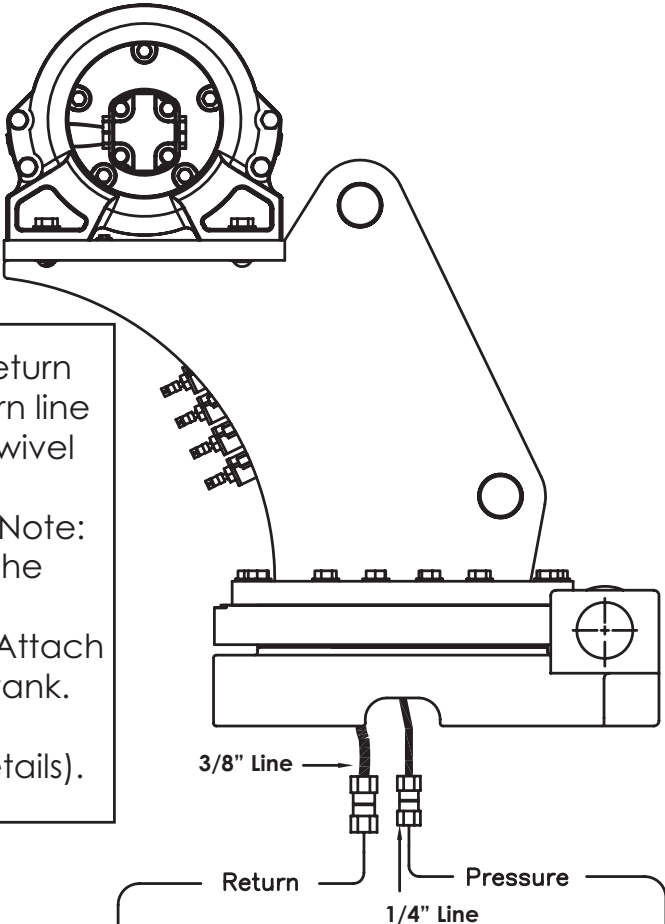

**Typical Stabilizer Valve  
with Power Beyond Capabilities**

# Hydraulic System

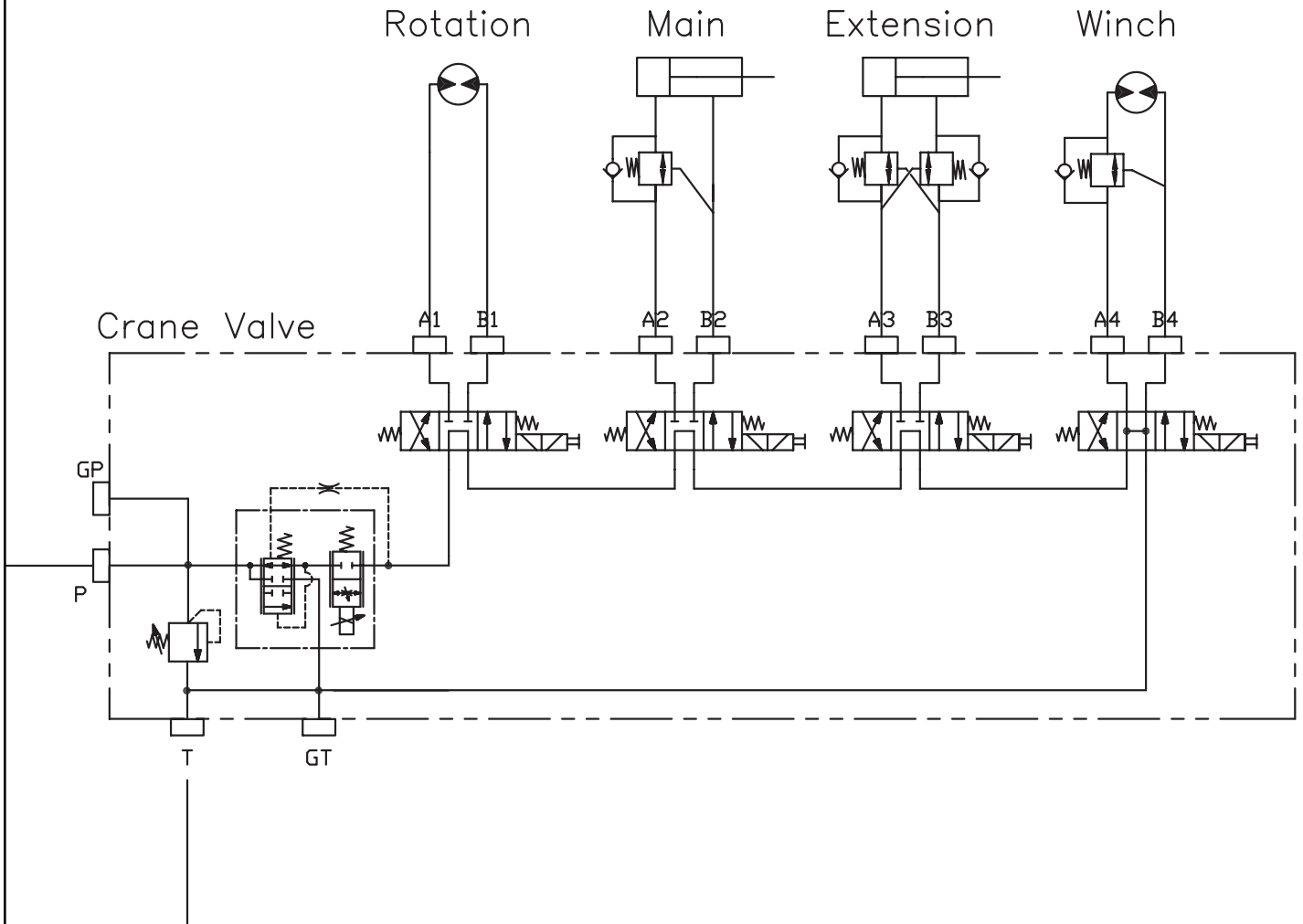



## Face Seal/O-Ring Size Chart

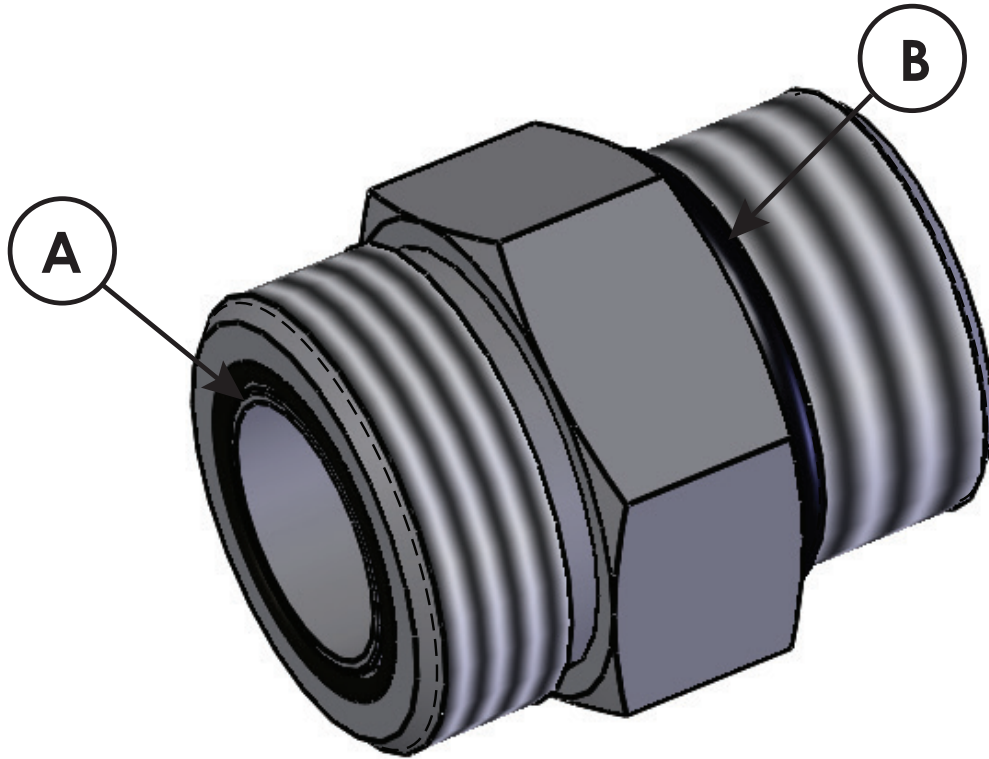

Hose Size	Fitting Size	Face Seal (A) Stellar® PN	O-ring Boss (B) Stellar® PN
1/4"	#4	C2027	D1245
3/8"	#6	C2028	D1246
1/2"	#8	C2029	D1247
5/8"	#10	32223	D1248
3/4"	#12	D1244	D1249
1"	#16		D1250

# Stability Procedure

## Definition of Stability for the Stellar Telescopic Crane Products:

A truck is stable until the load cannot be lifted off the ground with the winch, without tipping over the truck. Every Stellar crane installed must be tested for stability to determine the actual load capacity of the final truck package. The actual test data must be recorded and supplied with the truck at the time of in-service and should be kept with the truck at all times. The following procedure will test the truck package for stability and will provide a stability capacity chart. The load limit information shown on the stability capacity chart is formulated on 85% tipping.

## Set Up:

1. Locate the truck on a test course in position for loading and engage travel brakes.
2. Set stabilizers so that they make contact with firm, level footing.
3. Operate the crane under partial load to assure operator proficiency and proper machine function.
4. Put the radio into Stability Test Mode:
  - A. Push the middle four switches up and hold until "STB" appears on the screen (approximately 5 seconds.)



- B. At this point, the crane will have enough capacity to handle the weight for the stability test.
- C. The radio will timeout of stability mode after 30 minutes or when the E-Stop button is pushed.

*Note: The radio can only be put into stability mode five times. After that, the radio would have to be returned to Stellar to be reprogrammed to allow additional stability testing. All other radio functions will work properly even if stability mode is not available.*

# Stability Procedure Continued...

## 3315 Stability Data

**Max Horizontal Reach:** 188" (From the center of rotation to boom tip)

**Stability Test Weight:** 905 lbs.

## Test Procedure

1. Rotate the crane into Zone 1 position.
2. With the crane fully retracted and the boom horizontal, winch the test weight off the ground. Note: Keep weight within six inches of the ground at all times.
3. Extend the boom outward until full extension has been reached or until the truck becomes unstable (Again, use the winch to keep the weight within six inches of the ground.)
4. If the boom goes full extension without becoming unstable, the crane is termed stable for this zone and 100% can be written in the Zone 1 data box.
5. If the truck becomes unstable prior to going full extension, retract the boom until the truck becomes stable and measure the horizontal reach in this position (center of rotation to boom tip). This is the stable horizontal reach for this zone. Stable horizontal reach divided by Maximum horizontal reach multiplied by 100 equals the percentage of rated capacity for this zone. Use the following formula to determine the percentage of rated capacity:

$$\frac{\text{Stable Horizontal Reach}}{\text{Max Horizontal Reach}} \times 100 = \text{Percentage of Rated Capacity}$$

6. Record this number in the data box for Zone 1. This is the revised capacity due to stability for this zone.
7. Repeat this procedure for each zone until the worksheet is completed.
8. This is the revised capacity based on stability of this package.

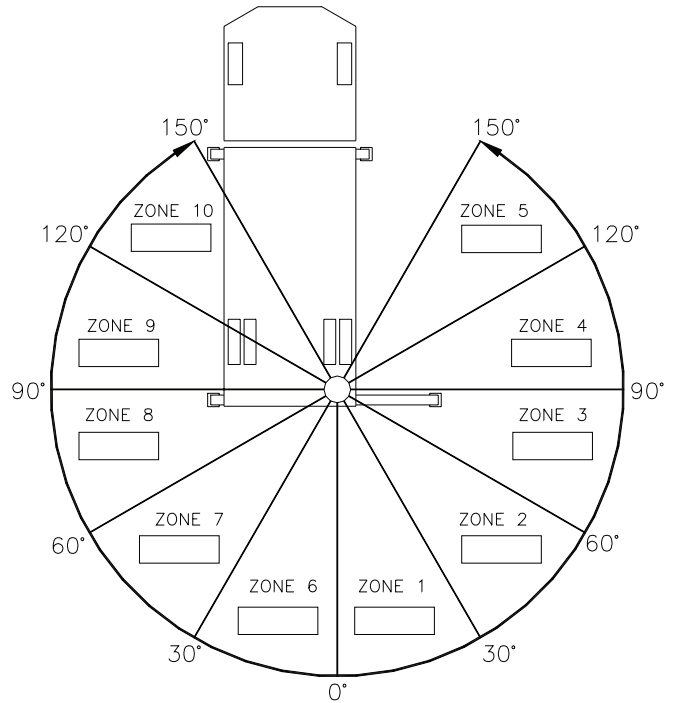

## Crane Load Level Indicator

Stellar® Cranes are shipped with a load level indicator that is used to determine if the truck is level (side to side) before using the crane to pick/move a load. This level should be installed in the isolated crane compartment of the body. If level indicator is missing or damaged, please contact Stellar Customer Support for a replacement.



PN 76483

# Decal Placement - PN 70303

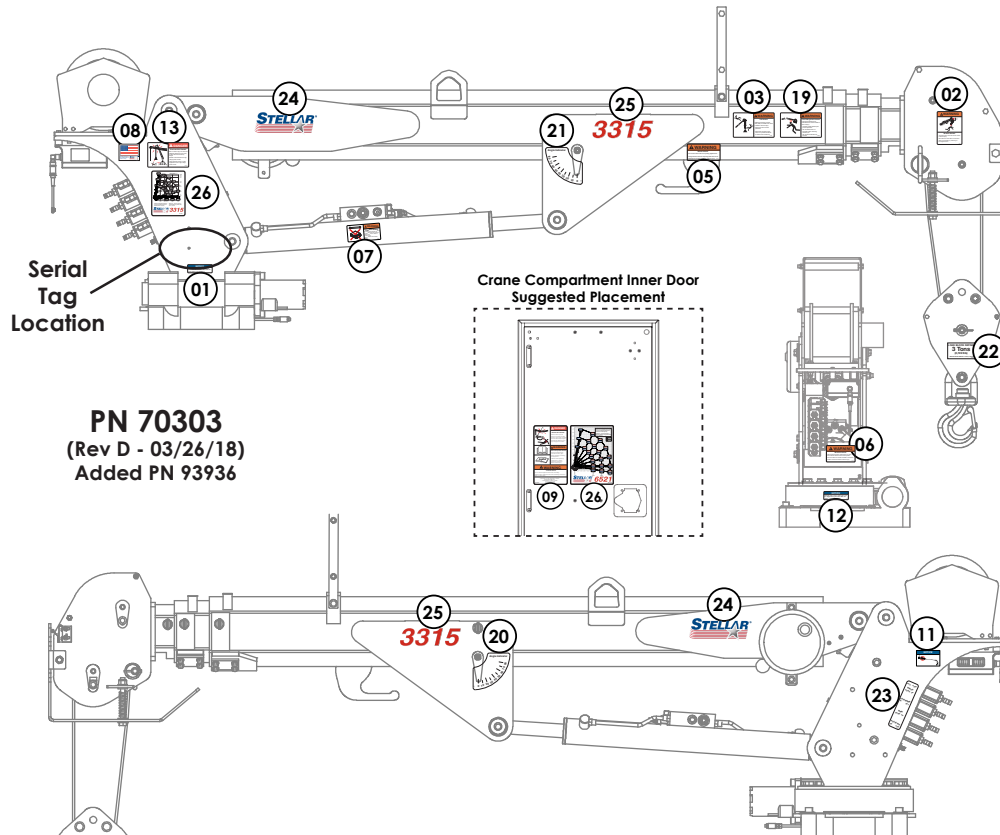

**PN 70303**  
(Rev D - 03/26/18)  
Added PN 93936

## GENERAL DECAL PACKAGE - PN 90470

ITEM	PN	DESCRIPTION	LOCATION	QTY
01	15172	DECAL ASME/ANSI B30.22/B30.5	Crane Mast	1
02	12300	DECAL WARNING TWO BLOCKING	Crane Horse Head	1
03	12451	DECAL WARNING HOISTING PERSONNEL	Main Boom	1
04	15171	DECAL GREASE WORM	Crane Base	1
05	24712	DECAL WARNING STOW HOOK	Crane Boom above stow hook	1
06	25159	DECAL WARNING MANUAL OVERRIDES	Under Valve Bank	1
07	28256	DECAL WARNING OVERLOAD DEVICE	Main Cylinder	1
08	35234	DECAL STELLAR MADE IN THE USA	Main Boom	1
09	93936	DECAL SAFETY & SERVICE MECH BODY DOOR	Crane Compartment	1
10	4188	DECAL ROTATION ALIGNMENT	Crane Base	1
11	73929	DECAL PRESSURE WASH	Crane Mast	1
12	9188	DECAL ROTATE/GREASE	Crane Base	1
13	C1179	DECAL DANGER ELECTROCUTION SMALL	Crane Mast	1
14*	C4545	DECAL DANGER ELECTROCUTION LARGE	Four corners of the body/chassis	4
15*	C5910	DECAL STELLAR 4x9.5	Suggested: Rear body/tailgate	1
16*	C5911	DECAL STELLAR 2x4.5	Suggested: Side corners of body	3
17	D1196	DECAL ANGLE INDICATOR CS	Main Boom	1
18	D1197	DECAL ANGLE INDICATOR SS	Main Boom	1

## 3315 DECAL PACKAGE - PN 90472

ITEM	PN	DESCRIPTION	LOCATION	QTY
19	12452	DECAL WARNING MANUAL EXT	Main Boom	1
20	13819	DECAL ANGLE INDICATOR SS	Main Boom	1
21	13820	DECAL ANGLE INDICATOR CS	Main Boom	1
22	38205	DECAL SNATCH BLOCK 3 TON	Snatch Block	1
23	41068	DECAL VB CONTROL MECH CRANE	On side of Crane Mast	1
24	55128	DECAL STELLAR LOGO 2.75 x 7.75	Main Boom (Both Sides)	2
25	55129	DECAL IDENTIFICATION 3315	Main Boom (Both Sides)	2
26	70304	DECAL CAPACITY 3315	Main Boom and Crane Compartment	2

\*Not Shown

# Chapter 3 - Assembly Drawings

## Base Assembly - PN 19998

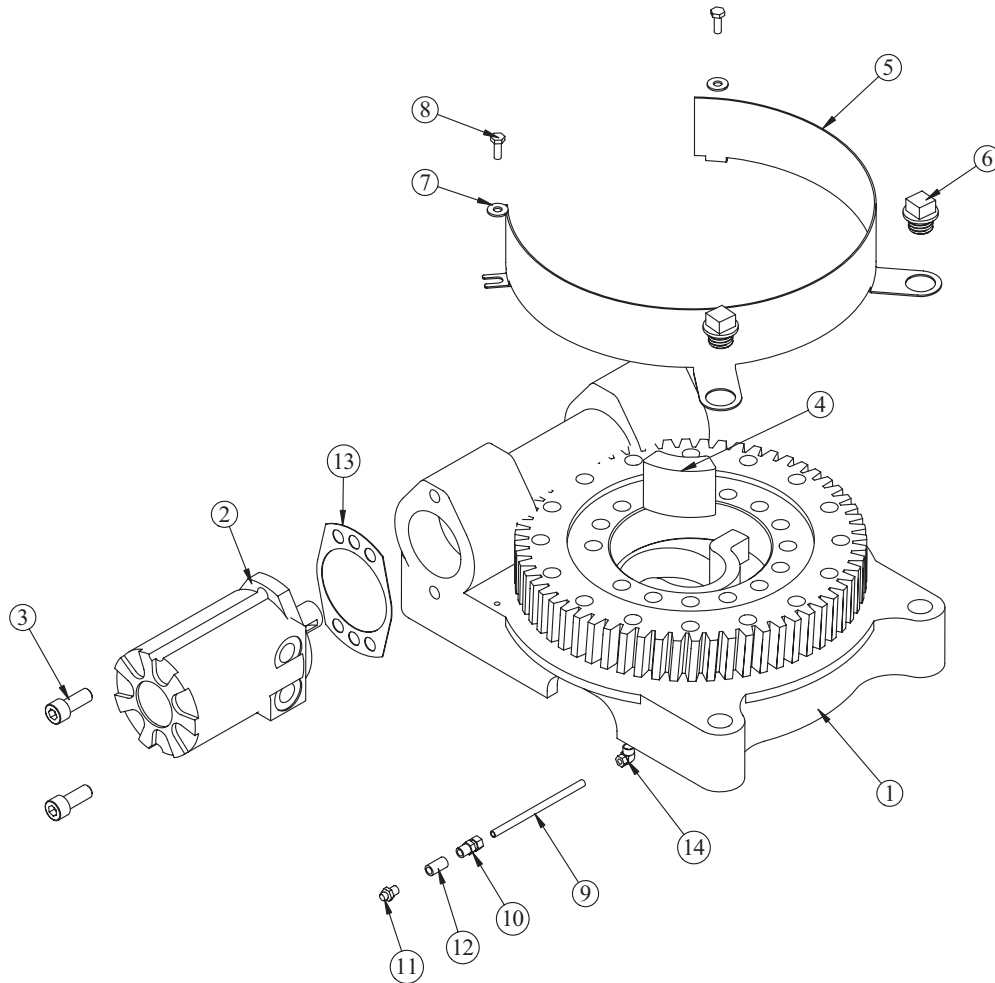

### PN 19998

ITEM	PART	DESCRIPTION	QTY.
1	16653	BEARING SWING DRIVE CAST	1
2	C6069	MOTOR HYD ROSS MK080613AAAB	1
3	D1307	CAP SCR 0.50-13X1.25 SHGR8 W/ RED PATCH	2
4	17750	STOP 3515	1
5	44601PC	GUARD TTB 5520 CRANE LZR	1
6	18948	CAP SCR 0.88-9 X .63 PLASTIC	2
7	0340	WASHER 0.25 FLAT	2
8	0479	CAP SCR 0.25-20X0.75 HHGR5	2
9	22393	TUBE AIR	1
10	D1345	FTG CPRSN 0.12NPT/0.25 TUBE	1
11	56589	ZERK 1/8 NPT STRAIGHT LONG THREAD	1
12	22161	FTG 2-2 FP-FP COUPLER STRAIGHT BRASS	1
13	21151	GASKET MOTOR 008-10056-1	1
14	D0240	FTG 4-2 CPRSN-MP 90	1

**GASKET SHOWN AS REFERENCE**

**D0240 SHOWN AS REFERENCE  
(INCLUDED WITH GEAR BEARING)**

**NOT SHOWN: TRIM EDGE C4759 (3FT)**

# Gear Bearing - PN 16653

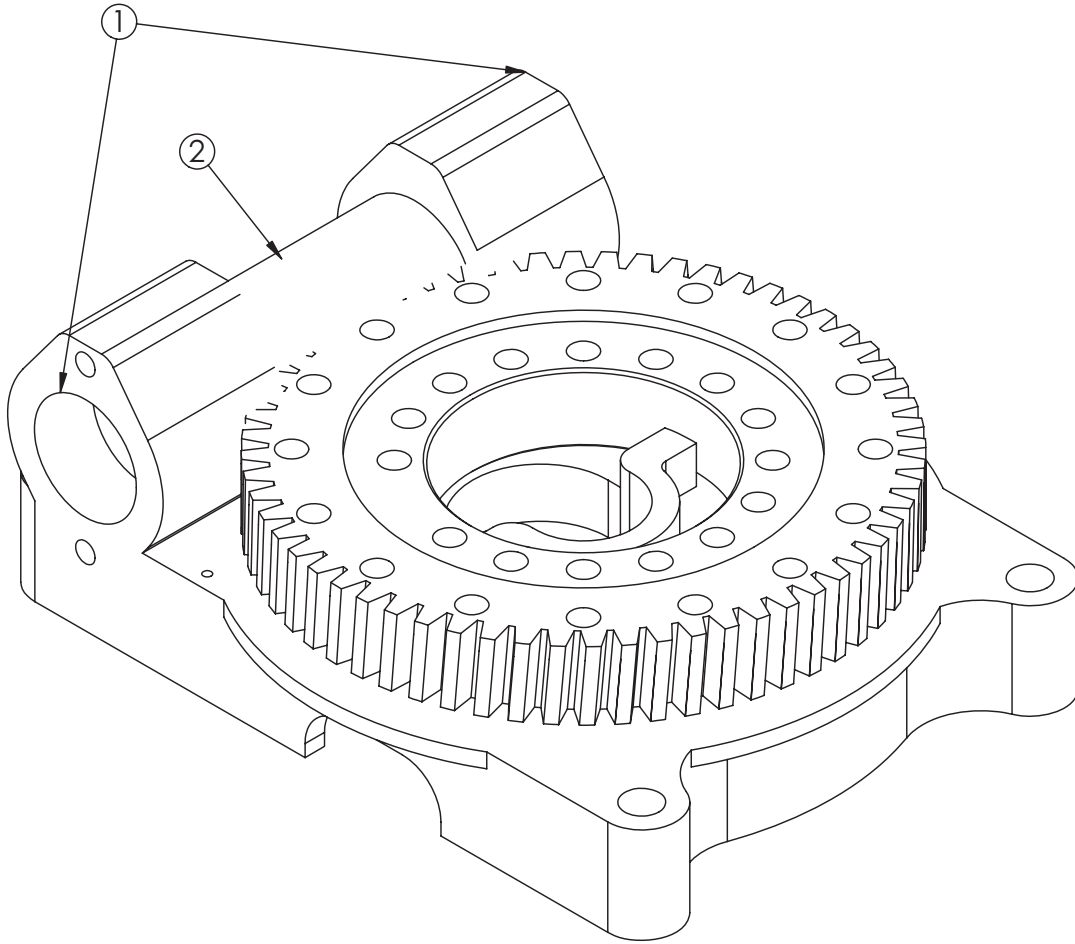

## PN 16653

ITEM	PART	DESCRIPTION	QTY.
1	27184	BEARING AND SEAL KIT	1
2	62488	WORM 3315/4420/5520 GEAR PROD 170-10058-1	1

# Mast Assembly (CDT Version) - PN 69785

**RADIO RECEIVER  
RUBBER MOUNT  
64977**

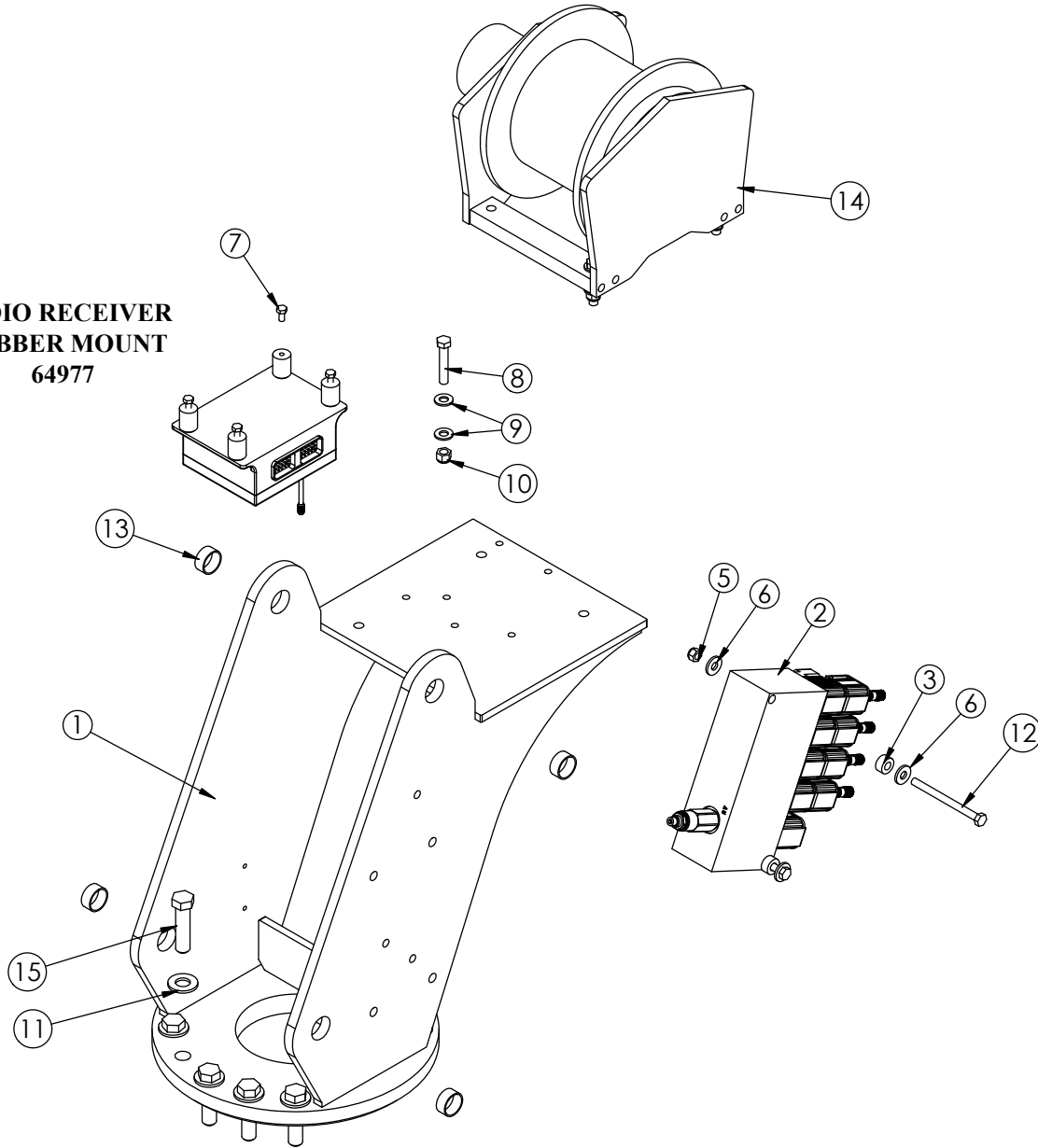

**PN 69785**

ITEM	PART	DESCRIPTION	QTY.
1	69373	MAST 4421	1
2	72666	VB 4 SECT W/PROP STER4GPM-8 VALVE DEUTSCH	1
3	27813	COLLAR 0.38X0.75X0.38 UHMW	2
5	0342	NUT 0.31-18 HHGR5 NYLOC	2
6	0343	WASHER 0.31 USS FLAT ZINC	4
7	10976	CAP SCR 6MMX12MM HH 10.9(GR8)	4
8	C1006	CAP SCR 0.38-16X2.00 HHGR8	4
9	C6353	WASHER 0.38 SAE FLAT YELLOW GR8	8
10	56673	NUT 0.38-16 HHGR8 NYLOC	4
11	C5902	WASHER 0.63 SAE FLAT YELLOW GR8	10
12	0491	CAP SCR 0.31-18X4.00 HHGR5	2
13	20362	BUSHING BPC16DXR08 1.00X.50	4
14	19511	WINCH 1600 3315 CRANE	1
15	66838	CAP SCR 0.63-11X2.50 HHGR8 W/RED PATCH	10

# Mast Assembly (Non-CDT Version) - PN 70072

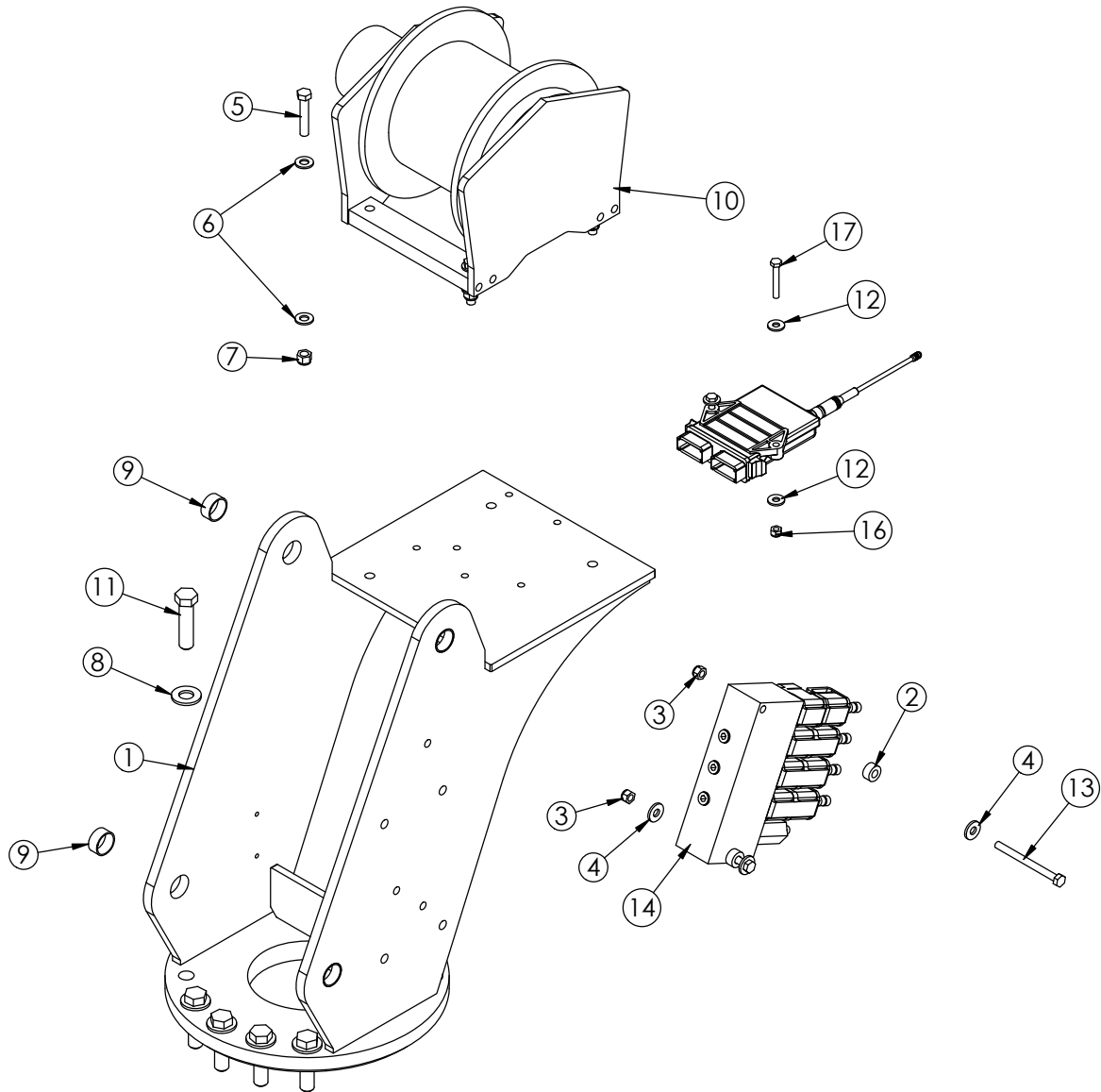

## PN 70072

ITEM	PART	DESCRIPTION	QTY.
1	69373	MAST 4421	1
2	27813	COLLAR 0.38X0.75X0.38 UHMW	2
3	0342	NUT 0.31-18 HHGR5 NYLOC	2
4	0343	WASHER 0.31 USS FLAT ZINC	3
5	C1006	CAP SCR 0.38-16X2.00 HHGR8	4
6	C6353	WASHER 0.38 SAE FLAT YELLOW GR8	8
7	56673	NUT 0.38-16 HHGR8 NYLOC	4
8	C5902	WASHER 0.63 SAE FLAT YELLOW GR8	10
9	20362	BUSHING BPC16DXR08 1.00X.50	4
10	19511	WINCH 1600 3315 CRANE	1
11	66838	CAP SCR 0.63-11X2.50 HHGR8 W/RED PATCH	10
12	0340	WASHER 0.25 USS FLAT ZINC	4
13	24139	CAP SCR 0.31-18X3.75 HHGR5	2
14	50591	VB 4 SECT ELECT ON/OFF STERLING4GPM	1
16	0333	NUT 0.25-20 HHGR5 NYLOC	2
17	0332	CAP SCR 0.25-20X1.75 HHGR5	2



# Power Unit Assembly (Electric Version Only) - PN 57939

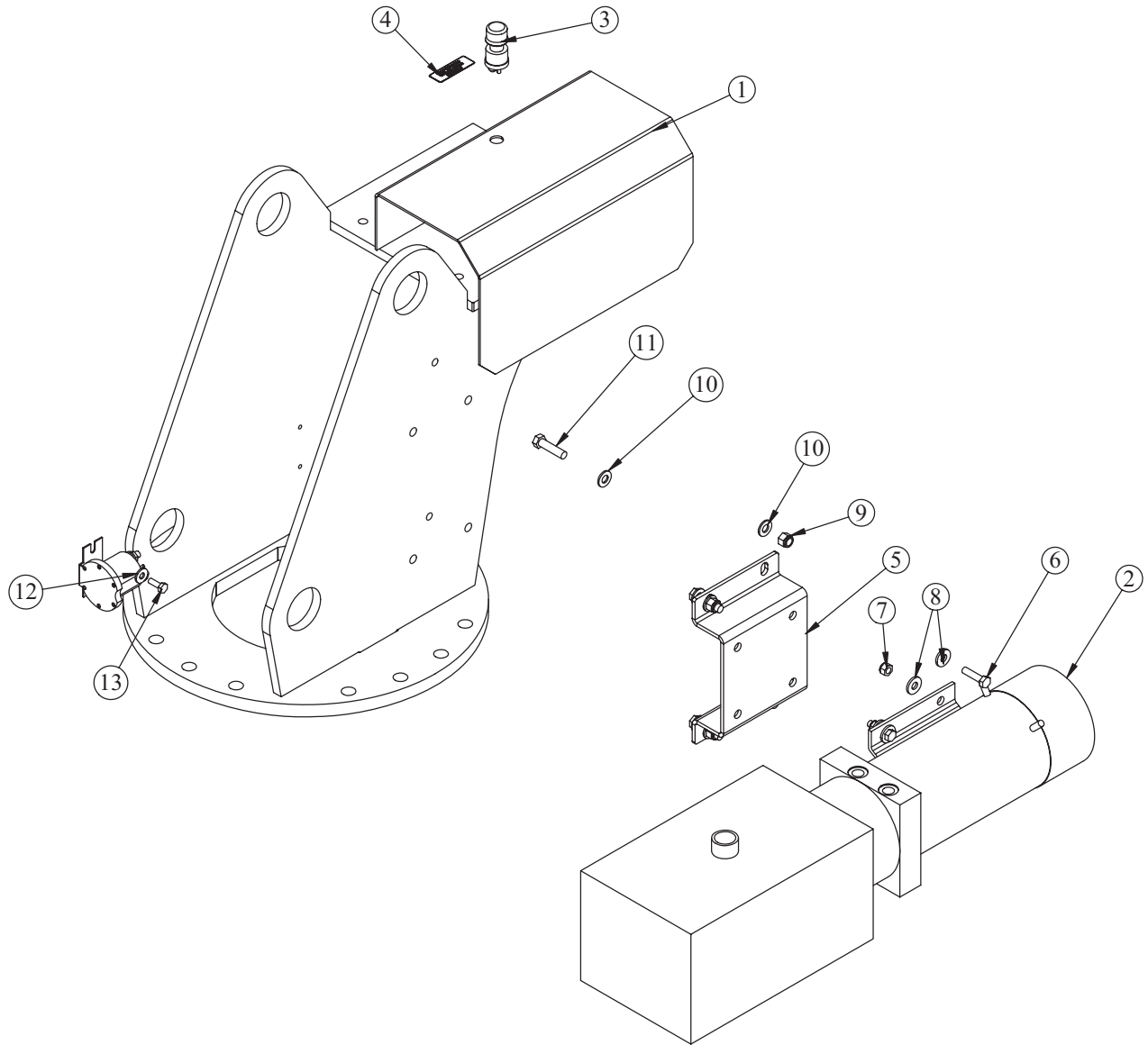

## PN 57939

ITEM	PART	DESCRIPTION	QTY.
1	19997	COVER POWER UNIT 5520	1
2	16994	POWER UNIT 12V 5520 HORIZ	1
3	17771	SWITCH PUSH BUTTON 9216-03	1
4	18472	DECAL MANUAL OPERATION 5520	1
5	59136	BRACKET POWER UNIT 5521	1
6	0485	CAP SCR 0.31-18X1.25 HHGR5	4
7	0342	NUT 0.31-18 HHGR5 NYLOC	4
8	0343	WASHER 0.31 USS FLAT	8
9	56673	NUT 0.38-16 HHGR8 NYLOC	4
10	C6353	WASHER 0.38 SAE FLAT YELLOW GR8	8
11	16962	CAP SCR 0.38-16X1.50 HHGR8	4
12	0340	WASHER 0.25 USS FLAT	2
13	0479	CAP SCR 0.25-20X0.75 HHGR5	2

### NOTES:

**SOLENOID 12V 24956**

# Main Boom Assembly (CDT Version) - PN 69786

**NOTE: INCLINOMETER MOUNTS  
INSIDE THE BOOM. VIEW SHOWS  
POSITION OF INCLINOMETER**

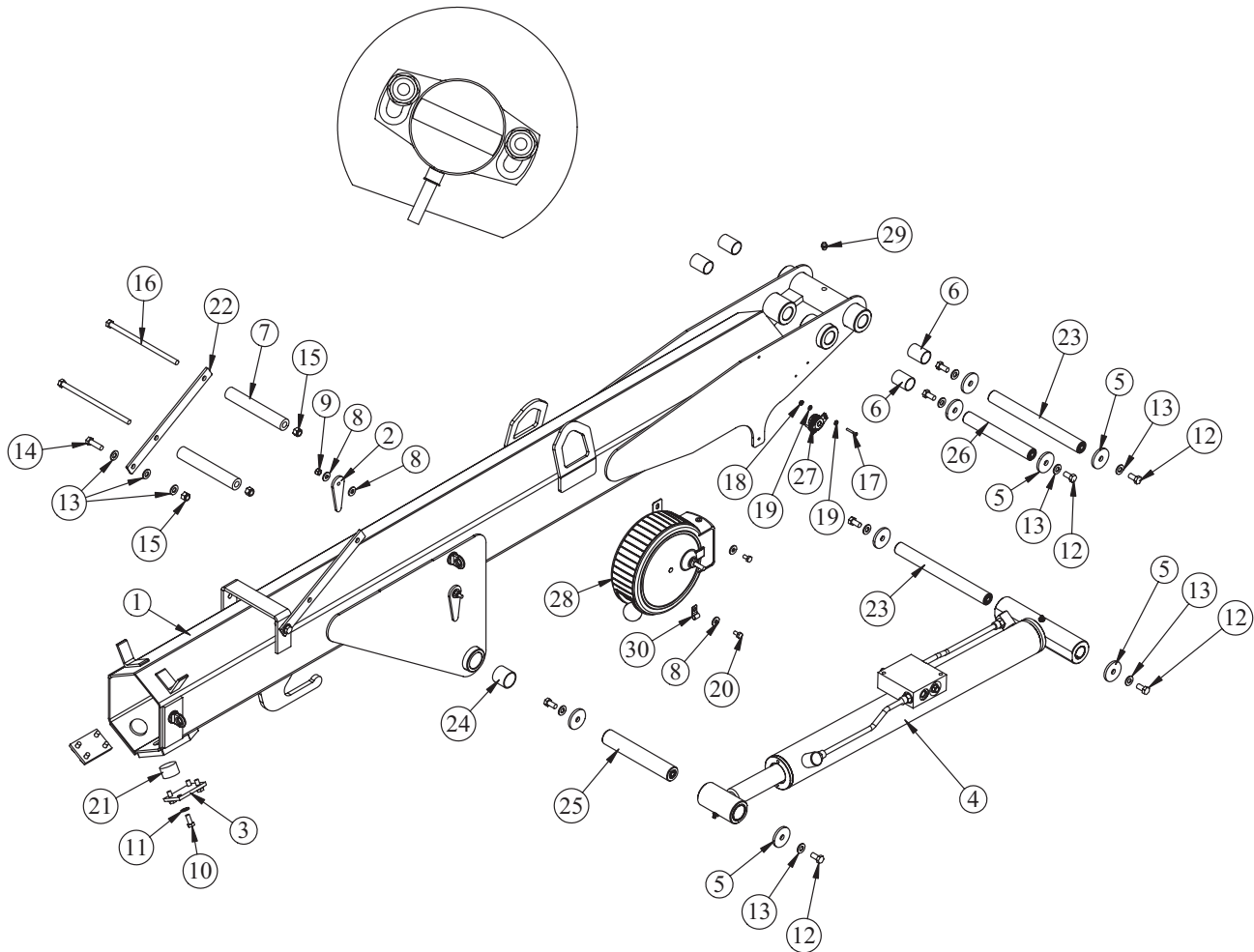

## PN 69786

ITEM	PART	DESCRIPTION	QTY.	ITEM	PART	DESCRIPTION	QTY.
1	69819	INNER BOOM 3315	1	14	0335	CAP SCR 0.38-16X1.25 HHGR5	2
2	19881PC	PLATE ANGLE INDICATOR 3315	2	15	0347	NUT 0.38-16 HHGR5 NYLOC	4
3	19497	PLATE 1ST EXT 3315 WEAR PAD	2	16	70213	CAP SCR 0.38-16X7.50 HHGR5	2
4	70081	CYLINDER ASM 3315 INNER	1	17	18618	SCREW #6-32X1.00 PHMS PH	2
5	9320	PIN CAP 0.44X1.75X0.19 YZ	8	18	D0076	NUT #6-32 HH NYLOC SS	2
6	0068	BUSHING BPC16DXR24 1.00X1.50	4	19	18765	WASHER #6 SAE FLAT	4
7	69472	SPACER ROPE GUIDE 4421 UHMW	2	20	0478	CAP SCR 0.25-20X0.50 HHGR5	2
8	0340	WASHER 0.25 USS FLAT	6	21	19496	WEAR PAD .88X1.38 RND	2
9	0333	NUT 0.25-20 HHGR5 NYLOC	2	22	69470	BRKT ROPE GUIDE 4421	2
10	0420	CAP SCR 0.31-18X0.75 HHGR5	8	23	69682CR	PIN 1.00X10.13 SR/D&T	2
11	5591	WASHER 0.31 SAE FLAT YELLOW GR8	8	24	0249	BUSHING BPC20DXR20 1.25X1.25	2
12	9843	CAP SCR 0.38-16X0.75 HHGR8	8	25	72606CR	PIN 1.25X7.38 D&T	1
13	C6353	WASHER 0.38 SAE FLAT YELLOW GR8	14	26	69681CR	PIN 1.00X7.38 SR/D&T	1
				27	53493	INCLINOMETER 60 DEG	1
				28	72602	CORD REEL ASM 15/21 FT CRANE	1
				29	c1592	ZERK 1/8 NPT STRAIGHT	1
				30	C5606	CLAMP 0.25 BLK VINYL	1

# Main Boom Assembly (Non-CDT Version) - PN 70080

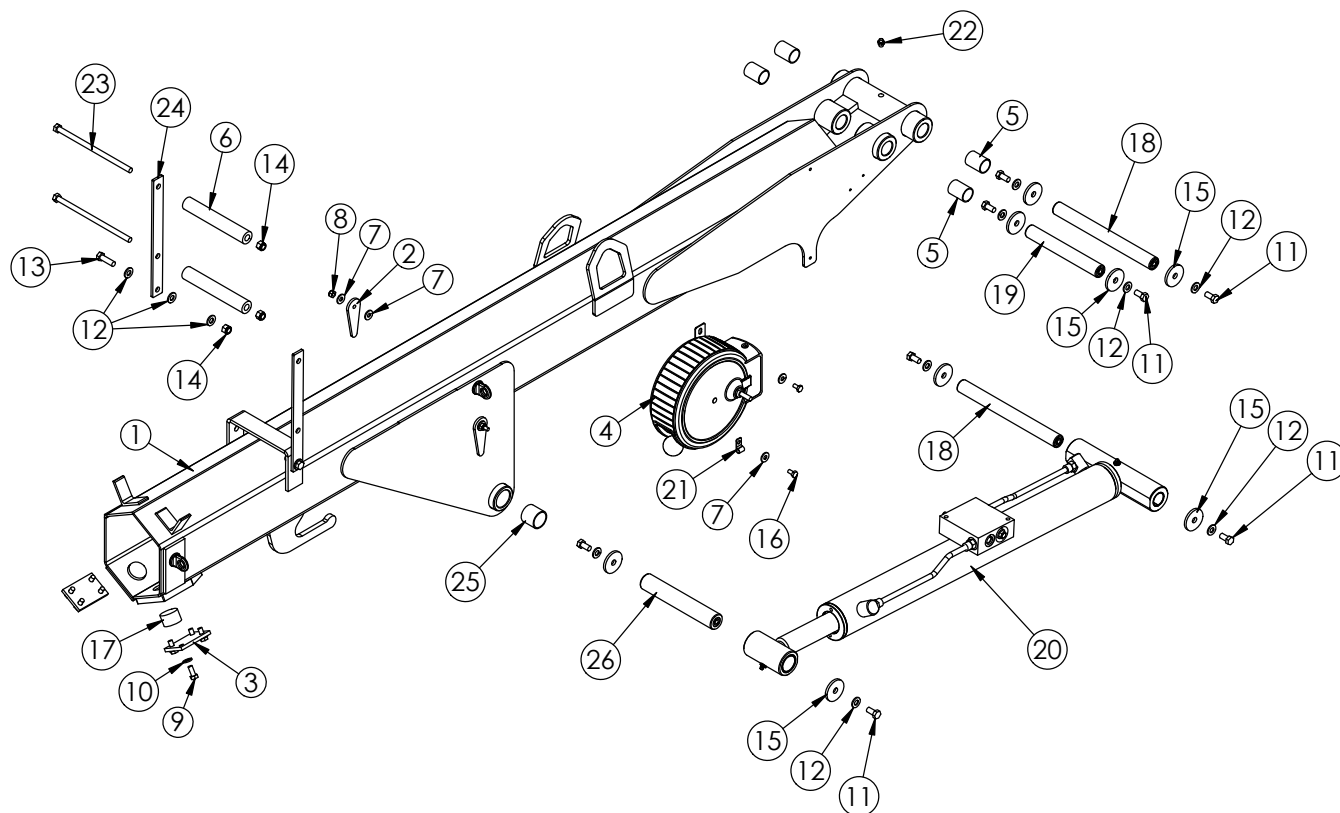

## PN 70080

ITEM	PART	DESCRIPTION	QTY.	ITEM	PART	DESCRIPTION	QTY.
1	69819	INNER BOOM 3315	1	14	0347	NUT 0.38-16 HHGR5 NYLOC	4
2	19881PC	PLATE ANGLE INDICATOR 3315	2	15	9320	PIN CAP 0.44X1.75X0.19 SS	8
3	19497PC	PLATE 1ST EXT 3315 WEAR PAD	2	16	0478	CAP SCR 0.25-20X0.50 HHGR5	2
4	72602	CORD REEL ASM 15/21 FT CRANE	1	17	19496	WEAR PAD .88X1.38 RND	2
5	0068	BUSHING BPC16DXR24 1.00X1.50	4	18	69682ZP	PIN 1.00X10.13 SR/D&T	2
6	69472	SPACER ROPE GUIDE 4421 UHMW	2	19	69681ZP	PIN 1.00X7.38 SR/D&T	1
7	0340	WASHER 0.25 USS FLAT ZINC	6	20	70081	CYLINDER ASM 3315 INNER	1
8	0333	NUT 0.25-20 HHGR5 NYLOC	2	21	C5606	CLAMP 0.25 BLK VINYL	1
9	0420	CAP SCR 0.31-18X0.75 HHGR5	8	22	c1592	ZERK 1/8 NPT STRAIGHT	1
10	5591	WASHER 0.31 SAE FLAT YELLOW GR8	8	23	70213	CAP SCR 0.38-16X7.50 HHGR5	2
11	9843	CAP SCR 0.38-16X0.75 HHGR8	8	24	69470PC	BRKT ROPE GUIDE 4421	2
12	C6353	WASHER 0.38 SAE FLAT YELLOW GR8	14	25	0249	BUSHING BPC20DXR20 1.25X1.25	2
13	0335	CAP SCR 0.38-16X1.25 HHGR5	2	26	72606CR	PIN 1.25X7.38 D&T	1

# Extension Boom Assembly - PN 69787

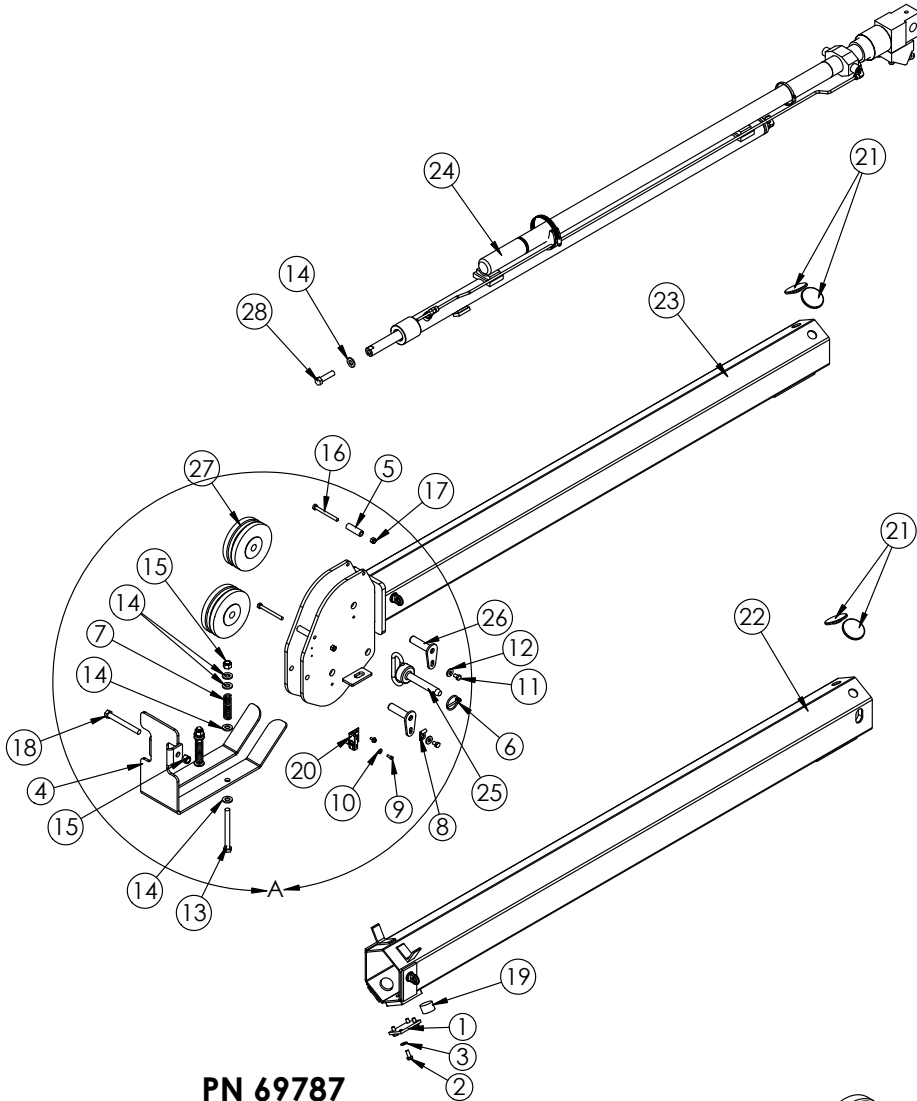

## PN 69787

ITEM	PART	DESCRIPTION	QTY.
1	19497PC	PLATE 1ST EXT 3315 WEAR PAD	2
2	0420	CAP SCR 0.31-18X0.75 HHGR5	8
3	5591	WASHER 0.31 SAE FLAT YELLOW GR8	8
4	51903PC	PLATE CRADDLE 6620/6628	1
5	27719	SPACER BOOM TIP 6620 UHMW	2
6	5753	PIN 0.19X1.56 LYNCH	1
7	27710	SPRING ANTI 2 BLOCK CRADLE A2B	2
8	31279	CLAMP 0.31 BLK VINYL	1
9	31132	CAP SCR #10-24X0.550 SH SS 18-8	2
10	D0178	WASHER #10 SAE FLAT ZINC	2
11	0484	CAP SCR 0.31-18X0.50 HHGR5	2
12	0343	WASHER 0.31 USS FLAT ZINC	2
13	C1000	CAP SCR 0.50-13X5.00 HHGR5	2
14	D0790	WASHER #10 SAE FLAT YELLOW GR8	9
15	C6106	NUT 0.50-13 HHGR5 NYLOC	3
16	12178	CAP SCR 0.31-18X3.25 HHGR5	2
17	0342	NUT 0.31-18 HHGR5 NYLOC	2
18	0507	CAP SCR 0.50-13X4.50 HHGR5	1
19	19496	WEAR PAD .88X1.38 RND	2
20	35105	SWITCH LIMIT E1117-B9111-6C	1
21	9991	WEAR PAD 0.19X2.50 RND NYLATRON	4
22	69788	EXT BOOM 1ST 3315	1
23	69792	EXT BOOM 2ND 3315	1
24	69817	CYLINDER EXT ASM 3315 1.5/1.5	1
25	17007	PIN HITCH 0.75X4.00	1
26	19996ZP	PIN TEAR DROP .75X2.88	2
27	16363	SHEAVE 3515 5.50 DIA .25R/1.94THK	2
28	10548	CAP SCR 0.50-13X1.50 HHGR8	1

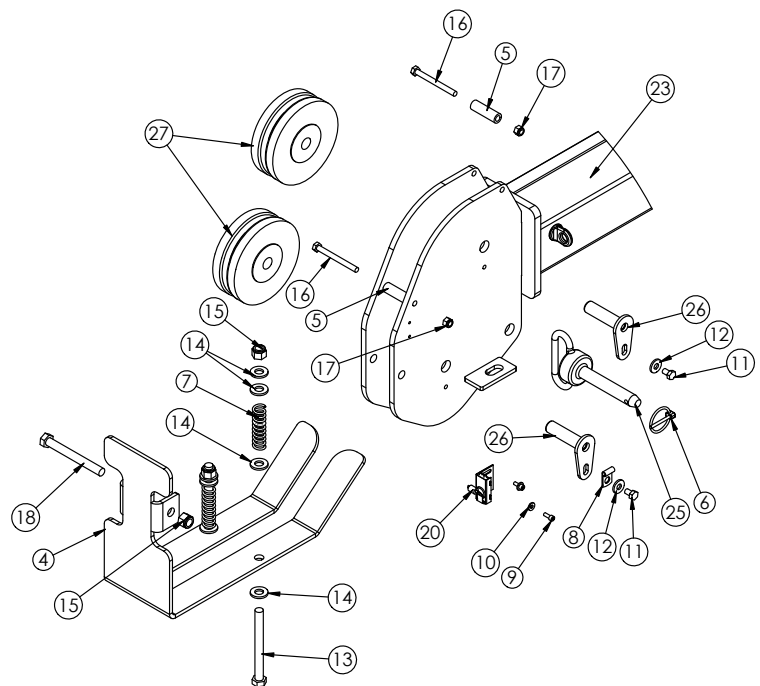

# Extension Boom Assembly (1 Hyd/1 Manual) - PN 69902

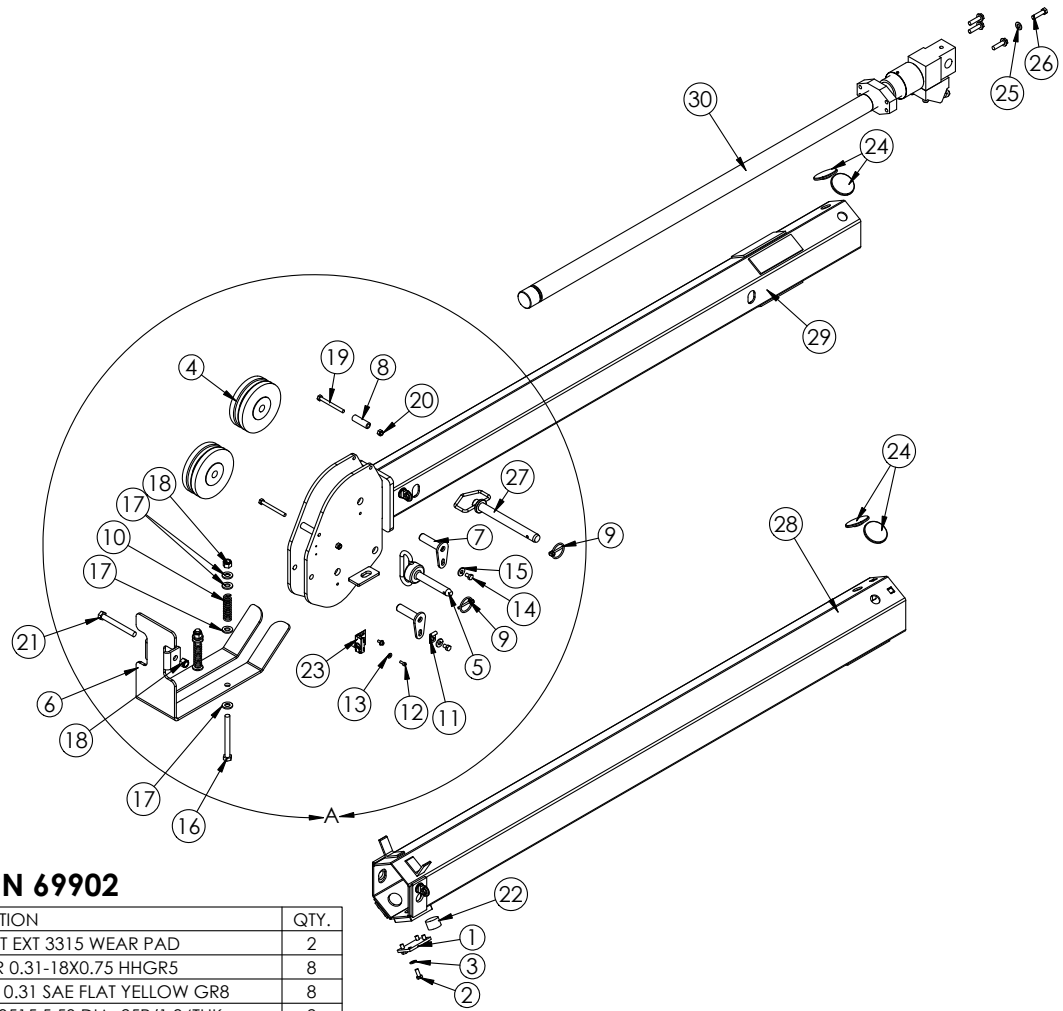

## PN 69902

ITEM	PART	DESCRIPTION	QTY.
1	19497PC	PLATE 1ST EXT 3315 WEAR PAD	2
2	0420	CAP SCR 0.31-18X0.75 HHGR5	8
3	5591	WASHER 0.31 SAE FLAT YELLOW GR8	8
4	16363	SHEAVE 3515 5.50 DIA .25R/1.94THK	2
5	17007	PIN HITCH 0.75X4.00	1
6	51903PC	PLATE CRADLE 6620/6628	1
7	19996ZP	PIN TEAR DROP .75X2.88	2
8	27719	SPACER BOOM TIP 6620 UHMW	2
9	5753	PIN 0.19X1.56 LYNCH	2
10	27710	SPRING ANTI 2 BLOCK CRADLE A2B	2
11	31279	CLAMP 0.31 BLK VINYL	1
12	31132	CAP SCR #10-24X0.550 SH SS 18-8	2
13	D0178	WASHER #10 SAE FLAT ZINC	2
14	0484	CAP SCR 0.31-18X0.50 HHGR5	2
15	0343	WASHER 0.31 USS FLAT ZINC	2
16	C1000	CAP SCR 0.50-13X5.00 HHGR5	2
17	D0790	WASHER 0.50 SAE FLAT YELLOW GR8	8
18	C6106	NUT 0.50-13 HHGR5 NYLOC	3
19	12178	CAP SCR 0.31-18X3.25 HHGR5	2
20	0342	NUT 0.31-18 HHGR5 NYLOC	2
21	0507	CAP SCR 0.50-13X4.50 HHGR5	1
22	19496	WEAR PAD .88X1.38 RND	2
23	35105	SWITCH LIMIT E1117-B9111-6C	1
24	9991	WEAR PAD 0.19X2.50 RND NYLATRON	4
25	C6353	WASHER 0.38 SAE FLAT YELLOW GR8	4
26	16962	CAP SCR 0.38-16X1.50 HHGR8	4
27	57937	PIN HITCH 0.75X8.00	1
28	69903	EXT BOOM 1ST 3315 1H1M	1
29	69907	EXT BOOM 2ND 3315 CRADLE A2B 1H1M	1
30	69911	CYLINDER ASM 3315 1H1M	1

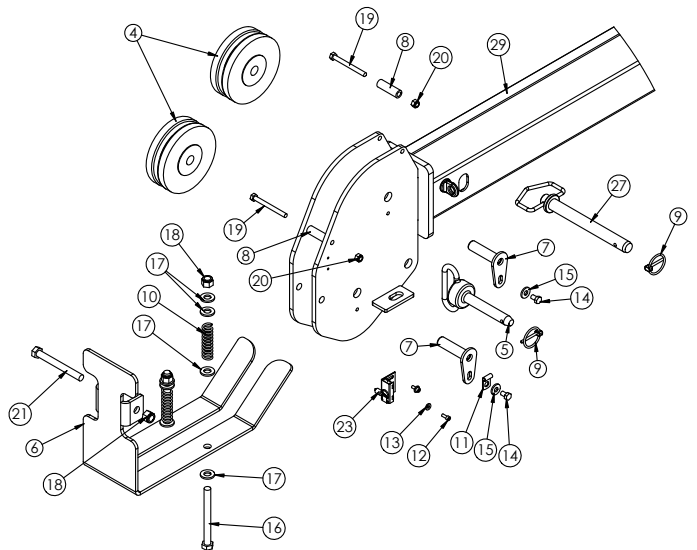

# Main Cylinder Assembly - PN 70081

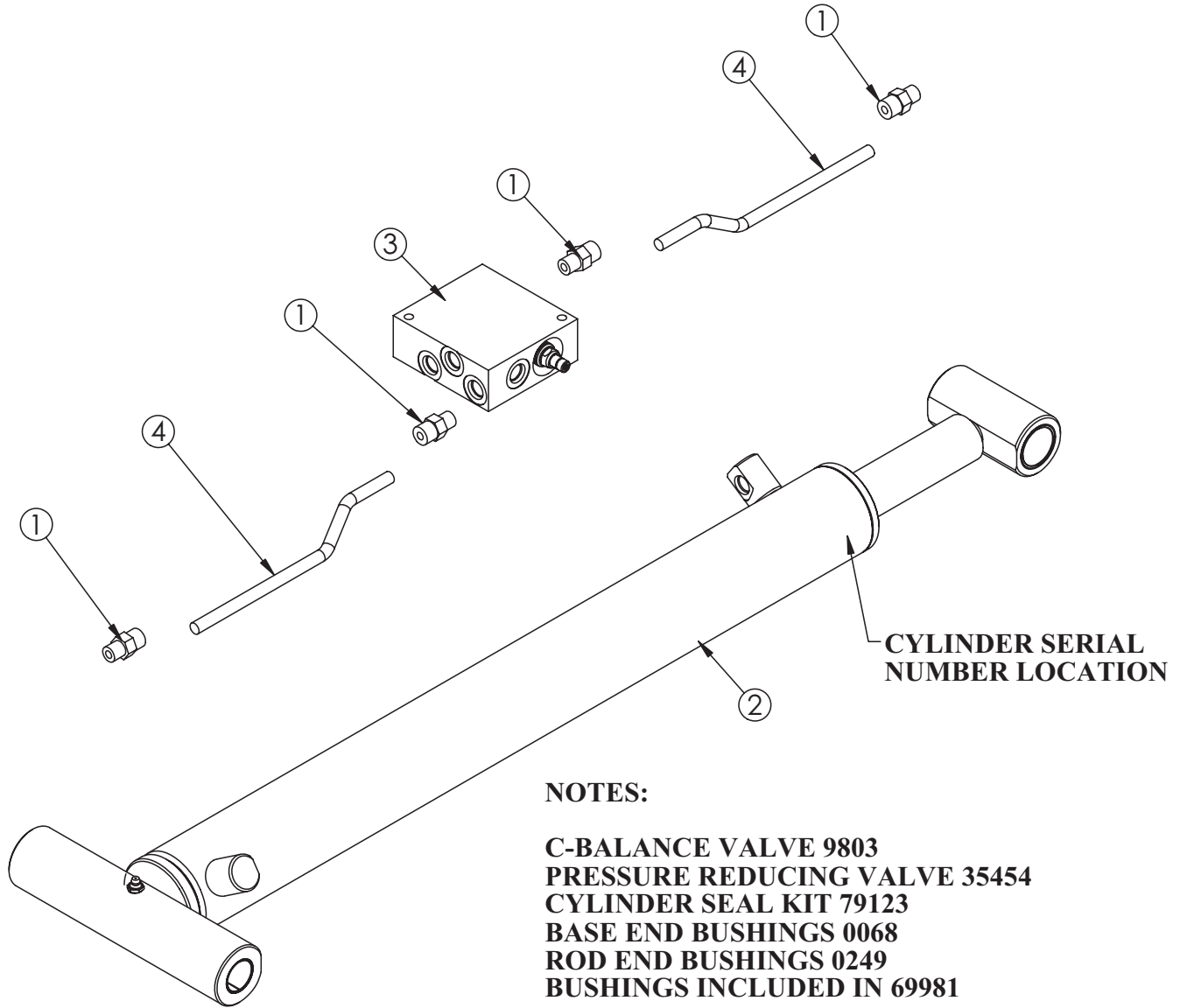

**NOTES:**

- C-BALANCE VALVE 9803**
- PRESSURE REDUCING VALVE 35454**
- CYLINDER SEAL KIT 79123**
- BASE END BUSHINGS 0068**
- ROD END BUSHINGS 0249**
- BUSHINGS INCLUDED IN 69981**

## PN 70081

ITEM	PART	DESCRIPTION	QTY.
1	0279	FTG 6-6 MFS-MORB STRAIGHT	4
2	69981	CYLINDER 2.50X22.50	1
3	13080	MANIFOLD SINGLE T1 1A 3500 PSI	1
4	12158	TUBE ASM 0.38X8.88 MAIN CYL 6620 YZ	2

# Extension Cylinder Assembly - PN 69817

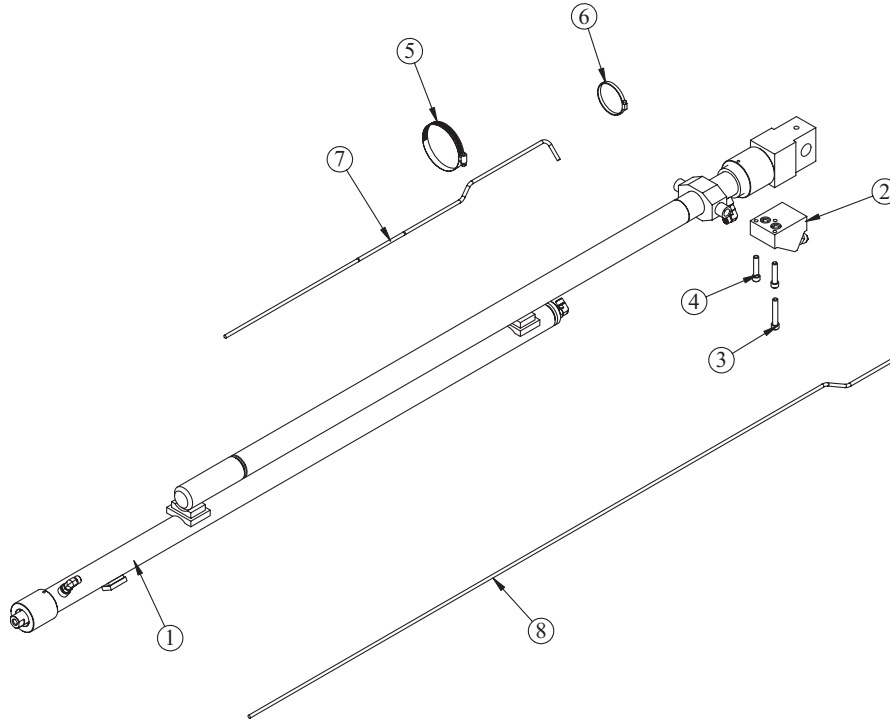

## PN 69817

ITEM	PART	DESCRIPTION	QTY.
1	69818	CYLINDER EXT 3315 2 STAGE 1.5/1.5	1
2	14115	MANIFOLD ASM 6620 EXT CBBB-LJN-XVN	1
3	14601	CAP SCR 0.38-16X2.25 SH ZC	1
4	11882	CAP SCR 0.38-16X1.75 SH ZC	2
5	24729	HOSE CLAMP #52 3.00 - 3.75	1
6	D0655	HOSE CLAMP #36 WRM GEAR	1
7	69954	TUBE ASM 0.25X33.50 EXT CYL 3315	1
8	69955	TUBE ASM 0.25X66.88 EXT CYL 3315	1

CYLINDER SERIAL NUMBER LOCATION

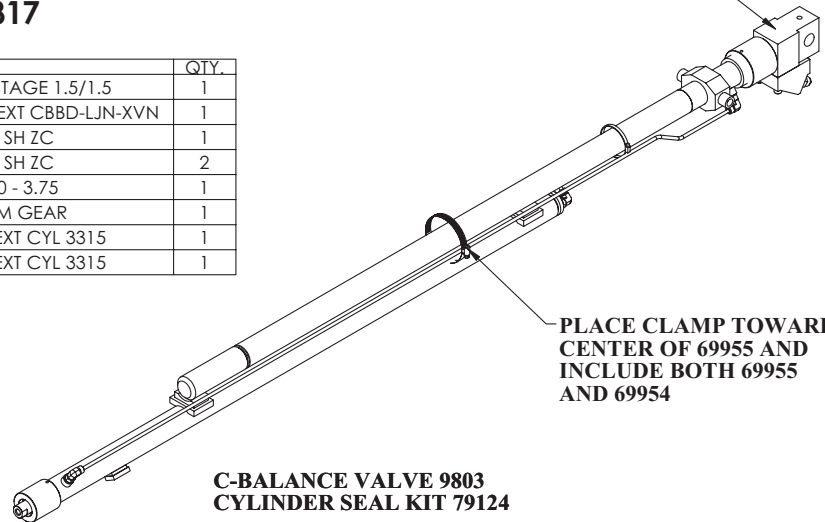

# Extension Cylinder Assembly (1 Hyd/1 Manual) - PN 69911

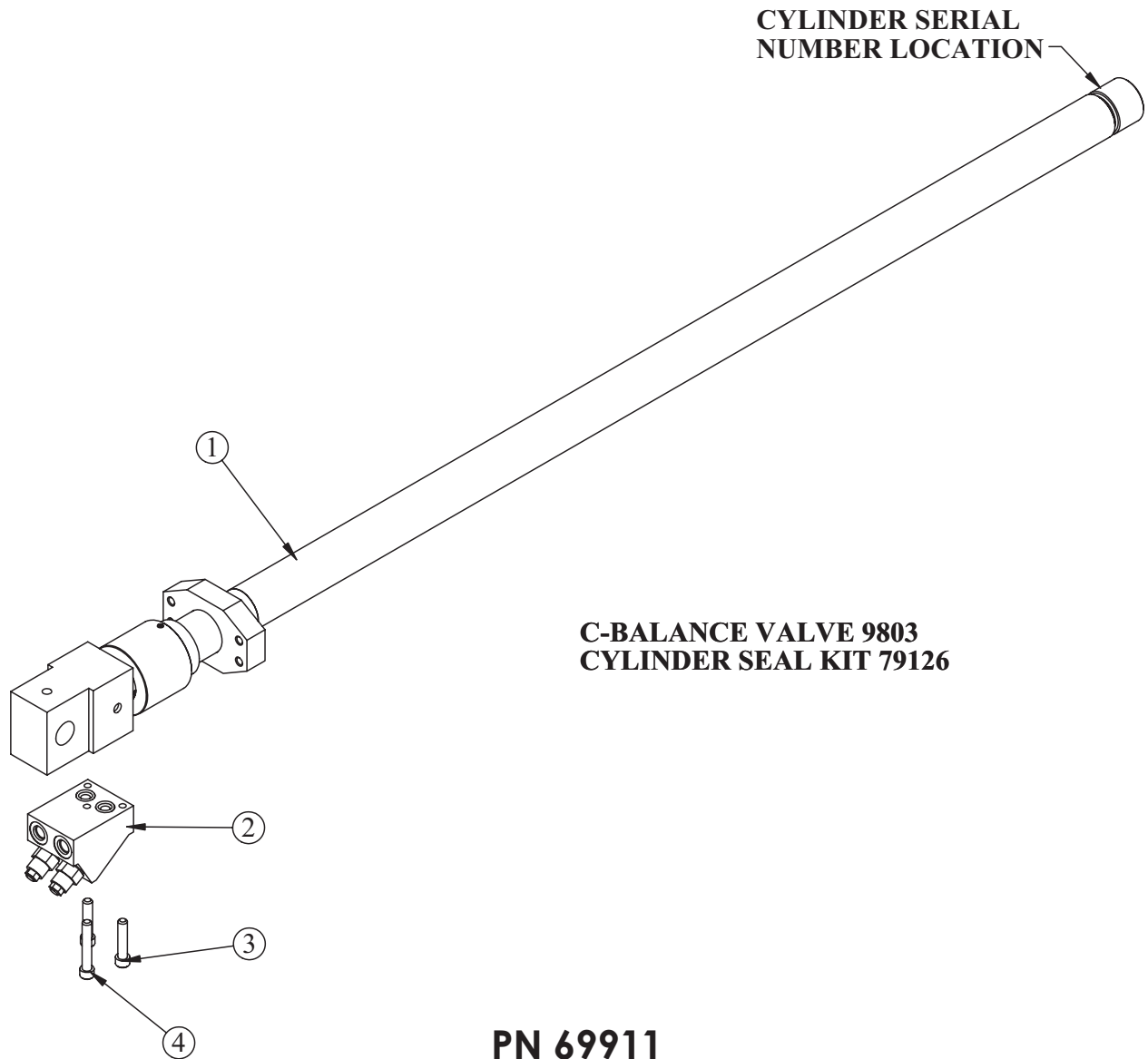

ITEM	PART	DESCRIPTION	QTY.
1	69953	CYLINDER 1.50X48.00 3315 MANUAL	1
2	14115	MANIFOLD ASM 6620 EXT CBBB-LJN-XVN	1
3	11882	CAP SCR 0.38-16X1.75 SH ZC	2
4	14601	CAP SCR 0.38-16X2.25 SH ZC	1



# Cable & Hook Assembly - PN 69978

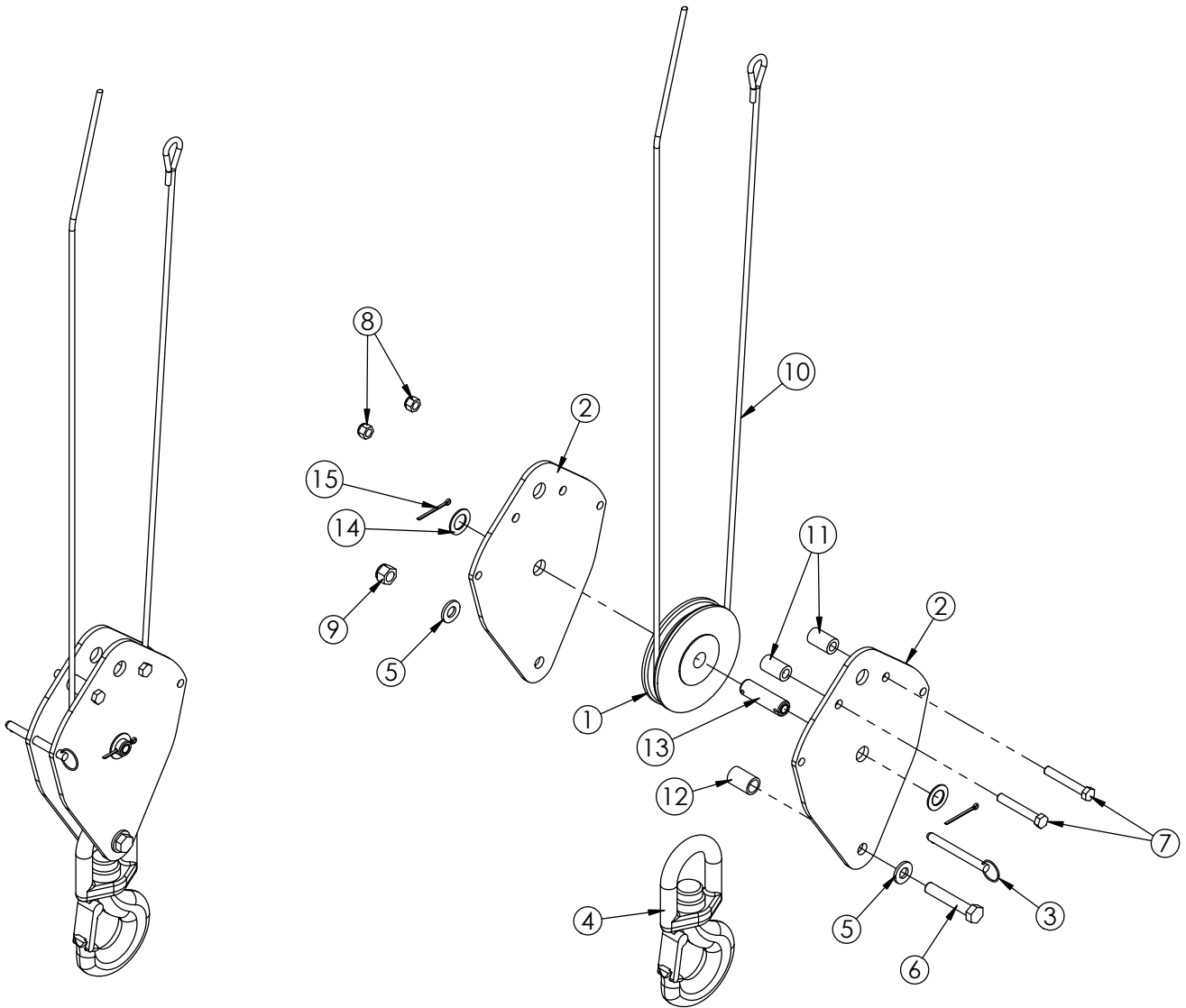

## PN 69978

ITEM	PART	DESCRIPTION	QTY.
1	16494	SHEAVE 3515 5.25 DIA .25R/1.12 THK	1
2	69979PC	PLATE SNATCH BLOCK 3315	2
3	9263	PIN .38X3.00 QUICK RELEASE	1
4	25842	HOOK 3 TON SWIVEL CROSBY 1028618	1
5	D0790	WASHER 0.50 SAE FLAT YELLOW GR8	2
6	0503	CAP SCR 0.50-13X2.75 HHGR5	1
7	0529	CAP SCR 0.38-16X2.50 HHGR5	2
8	0347	NUT 0.38-16 HHGR5 NYLOC	2
9	5468	NUT 0.50-13 HHGR8 NYLOC	1
10	17006	WIRE ROPE 1/4 7X19 GAC 65FT	1
11	72514	COLLAR 0.44X0.75X1.25 ZINC COATED	2
12	16607PC	SPACER 3315 SNATCH BLOCK	1
13	42524ZP	PIN 0.75X2.50 COTTER	1
14	0375	MACHY WASHER 0.75ID 14GA	2
15	37824	COTTER PIN .125X1.00	2

# 5-Function Radio Transmitter Assembly - PN 67894

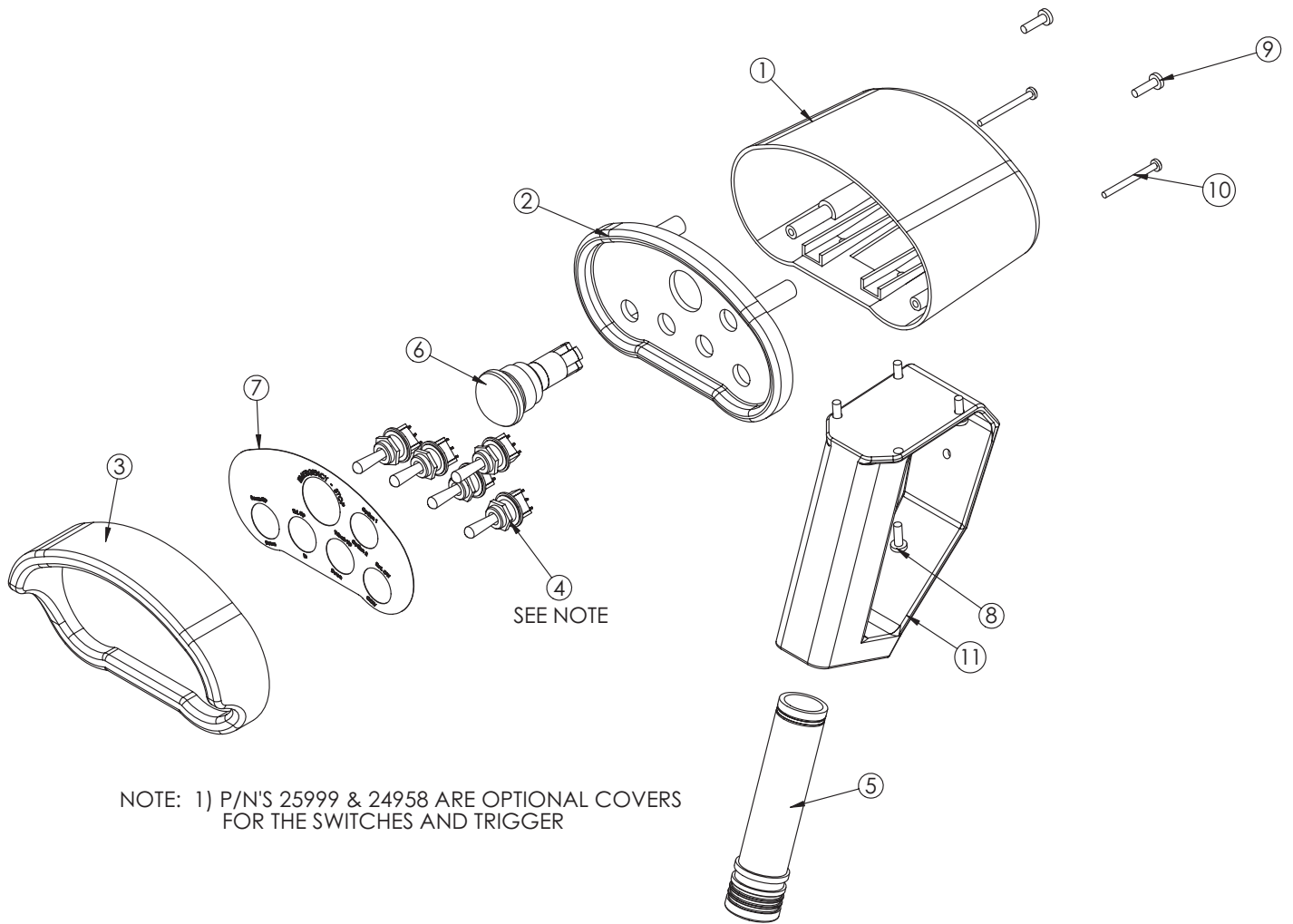

NOTE: 1) P/N'S 25999 & 24958 ARE OPTIONAL COVERS FOR THE SWITCHES AND TRIGGER

## PN 67894

ITEM	PART	DESCRIPTION	QTY.
1	20088	CONTROL HANDLE HOUSING 4 FCTN HET	1
2	51830	CONTROL HANDLE FACE PLT 5 FCTN	1
3	24385	GUARD RADIO SWITCH 4 FCTN	1
4	22600	SWITCH TOGGLE HET RADIO 63019300	5
5	35441	BATTERY TUBE AA HETRONIC RADIO	1
6	16975	SWITCH E STOP ASM HETRONIC RADIO	1
7	51831	DECAL CONTROL HANDLE 5 FCTN	1
8	38475	SCREW 4MMX12MM PHMS PH	4
9	36156	SCREW 4MMX14MM PHMS PH	2
10	29460	SCREW 3MMX35MM PHMS PH	2
11	50932	CONTROL HANDLE GRIP LESS TRIGGER HET H2	1

# Chapter 4 - Replacement Parts

---

Part Number	Description	Qty
D1204	Rotation Motor	1
25375	Relief Valve	1
35376	Seal Kit - Relief Valve	1
25381	Proportional Valve	1
25377	Solenoid Valve - Tandem G04571	3
25378	Solenoid Valve - Open G04591	1
25379	Seal Kit - Solenoid Valve	1
55126	Coil	8
13080	Manifold ASM - Main Lift Cylinder	1
9803	C-Balance Valve	2
11991	Plug - C-Balalance Valve	1
14115	Manifold ASM - Extension Cylinder	1
79123	Seal Kit - Main Lift Cyl	1
79124	Seal Kit - Extension Cyl	1
70491	Pressure Switch	1
28485	Pressure Transducer (CDT Radio Systems)	2
53493	Inclineometer	1
37980	Hydraulic Pressure Gauge	1
32302	FTG 4-4 MFS-MFS Swivel Straight	1
12171	FTG 6-6 MFS-MFS Swivel Straight	1
16363	Sheave	2
16494	Sheave	1
17006	Wire Rope	1
17007	Hitch Pin .75 x 4.00	1
57937	Hitch Pin .50 x 5.50	1
9263	Quick Release Pin .38 x 3.00	1
35105	Limit Switch	1
72602	Cord Reel	1
18468	12v Solenoid - 12v Hydraulic System	1
36435	200A Fuse	1
17771	Push Button Switch	1
44030	Start Solenoid Power Unit Motor	1
56648	O-Ring Power Unit Reservoir	1
44025	Power Unit Fill Cap	1
25842	Hook	1



Subject to Change without Notification.  
© 2018 Stellar Industries, Inc.