

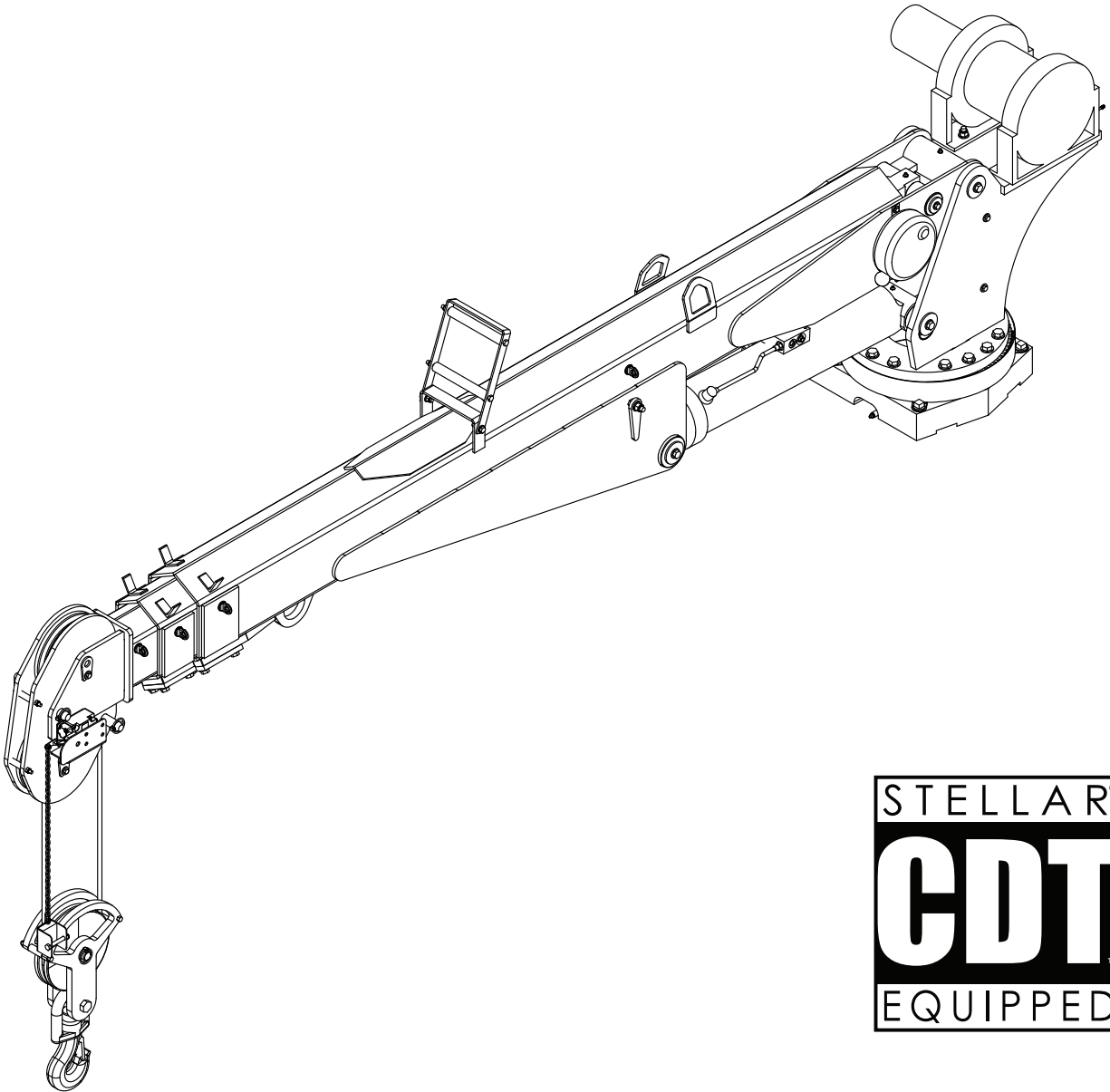

MODEL 10621

TELESCOPIC CRANE OWNERS' MANUAL

Installation • Assembly Drawings • Parts



Stellar Industries, Inc.

190 State Street

PO Box 169

Garner, IA 50438

800-321-3741

Fax: 641-923-2811

www.stellarindustries.com

Subject to Change without Notification.
© 2011 Stellar Industries, Inc.

Last Revision: 04/25/11

10621 Manual Revisions

Date of Revision	Section Revised	Description of Revision

Table of Contents

Chapter 1 - Specifications	1
Capacity Chart - Decal PN 54622	2
Chapter 2 - Installation	3
Installation Overview	4
Control Kit (Flip Sheave Version) - PN 52475	5
Control Kit (Cradle A2B Version) - PN 52861	6
Control Kit (Flip Sheave/Non-Boost) - PN 56566	7
Control Kit (Cradle A2B/Non-Boost) - PN 56642	8
Hydraulic Kit - PN 52264	9
Valve Bank - PN 52265	10
Hydraulic Installation	11
Winch Case Drain Installation	12
Hydraulic System	13
Stability Procedure	14
Decal Kit Placement - PN 54761	15
Chapter 3 - Assembly Drawings	17
Base Assembly - PN 18027	17
Mast Assembly - PN 52488	18
Main Boom - PN 52489	19
Extension Boom Assembly - PN 41546	20
Extension Boom Assembly Flip Sheave - PN 46309	21
Main Cylinder Assembly - PN 43839	22
Extension Cylinder Assembly - PN 28859	23
Cable & Hook Assembly - PN 44813	24
CDT™ Radio Transmitter Assembly - PN 56647	25
Chapter 4 - Replacement Parts	27

Find a Dealer Near You:

<http://www.stellarindustries.com/pages/dist/distsearch.htm>

For Technical Questions, Information, Parts, or Warranty, Call Toll-Free at

800-321-3741

Hours: Monday - Friday, 8:00 a.m. - 5:00 p.m. CST

Or email at the following addresses:

Technical Questions, and Information
Order Parts
Warranty Information

service@stellarindustries.com
 parts@stellarindustries.com
 warranty@stellarindustries.com

Chapter 1 - Specifications

Model 10621 Crane SPECIFICATION SHEET

Crane Rating:	60,000 ft-lb (8.29 TM)
Standard Boom Length:	11'0" (3.35 m) from CL of Crane
Boom Extension:	1st stage: Hydraulic 60"(152.4 cm) 2nd stage: Hydraulic 60"(152.4 cm)
Maximum Horizontal Reach:	21'0" (6.40 m) from CL of Crane
Maximum Vertical Lift: (from crane base)	23' (7.01 m)
Boom Elevation:	-5 to +80 degrees
Stowed Height (crane only)	35.5" (90.2 cm)
Mounting Space Required	20 x 21 inches (50.8 x 53.3 cm)
Approximate Crane Weight	2150 lbs (975 kg)
Controls	Radio control standard for all functions.
Winch Specification	
Rope Diameter:	7/16" (1.11 cm)
Line pull speed:	60 ft/min (18.29 m/min)
Max. single part line:	4500 lbs (2040 kg)
Max. double part line:	9000 lbs (4080 kg)
Rotation: (worm gear)	400 degree power
Lifting Capacities	5455 lbs @ 11'0" (2475 kg @ 3.35m) 3750 lbs @ 16'0" (1700 kg @ 4.88m) 2855 lbs @ 21'0" (1295 kg @ 7.01m)
Power Supply Required	PTO & Pump (8 gpm @ 3000 psi) (30.3 lpm @ 207 bar)

*Subject to change without notification

Capacity Chart - Decal PN 54622

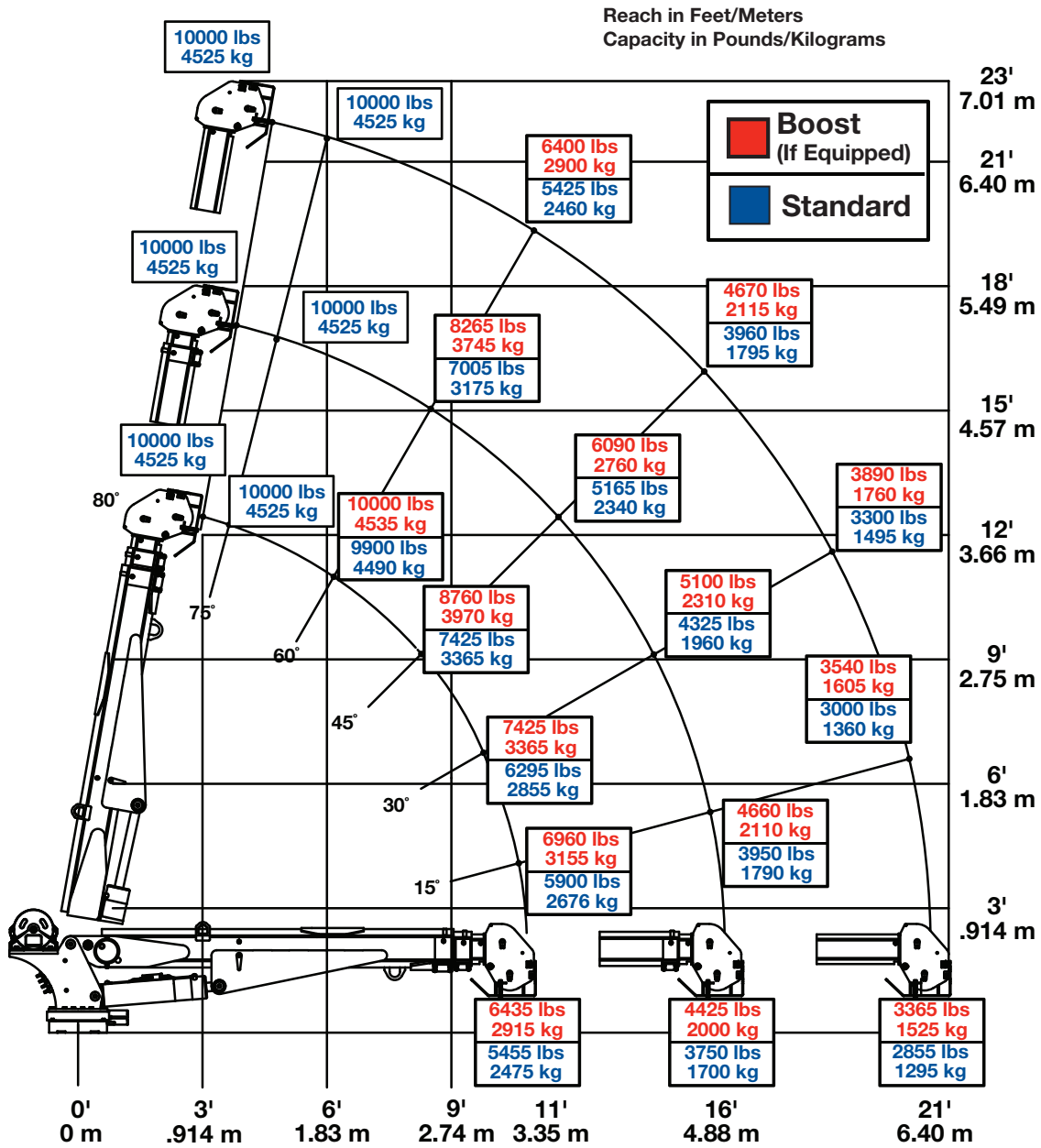

Weight of load handling devices are part of the load lifted and must be deducted from the capacity.

Maximum 1 - part line capacity is 5000 lbs (2265 kg). For greater loads, use 2 - part line.



Chapter 2 - Installation

Notice: Read this Page Before Installation of the Crane

General Installation

This chapter is designed to serve as a general guide for the installation of a Stellar 10621 Telescopic Crane on a Stellar Service Body. Each installation is considered unique so certain portions of this chapter may or may not apply to your direct application. If a question should arise during the installation process, please contact Stellar Customer Service at (800) 321 3741.

This crane is designed for use with a Stellar Service Body installed on a vehicle that meets the minimum chassis requirements of the crane. It is the installer's responsibility to assure that the crane is mounted on a platform that will support the maximum crane rating of this crane.

Notice:

PTO and Pump installation instructions are provided by the corresponding manufacturers. For more information on which PTO and Pump fit your application, please contact your local Stellar Distributor or Stellar Customer Service.

Important: When installing welder units to the service bodies, it is highly recommended that a surge protector is installed on the chassis batteries to protect the crane radio receiver, wiring and other electronic devices from an unexpected electrical spike or surge. Failure to do so could result in extensive damage to the service body and crane electrical circuit.

Installation Notice

According to Federal Law (49 cfr part 571), each final-stage manufacturer shall complete the vehicle in such a manner that it conforms to the standards in effect on the date of manufacture of the incomplete vehicle, the date of final completion, or a date between those two dates. This requirement shall, however, be superseded by any conflicting provisions of a standard that applies by its terms to vehicles manufactured in two or more stages.

Therefore, the installer of Stellar cranes and bodies is considered one of the manufacturers of the vehicle. As such a manufacturer, the installer is responsible for compliance with all applicable federal and state regulations. They are required to certify that the vehicle is in compliance with the Federal Motor Vehicle Safety Standards and other regulations issued under the National Traffic and Motor Vehicle Safety Act.

Please reference the Code of Federal Regulations, title 49 - Transportation, Volume 5 (400-999), for further information, or visit <http://www.gpoaccess.gov/nara/index.html> for the full text of Code of Federal Regulations.

Installation Overview

1. Determine that the mounting location for the 10621 crane is at least 20" x 21" (50.8 x 50.8 cm).
2. Use the detail below to drill 1.06" diameter holes into the mounting plate. Run tap on the threads of the base to be sure they are clean.
3. Use a crane or lifting device capable of lifting the weight of the Stellar crane. The Stellar 10621 weighs approximately 2150 lbs (975 kg). **Note: cranes are shipped with rotation positioned at 200 degrees of 400 degree system.** This will allow for easy installation of the crane and permanent connection of all hydraulic and electrical components prior to repositioning into the crane saddle.
4. Connect straps or chain from the lifting device to the lifting rings on the Stellar 10621.
5. Use six (6) 3" x 1" #8 bolts and six (6) #8 flat washers.
6. Install a washer on each bolt.
7. Apply Loctite Thread locker #277 to the bolts.
8. Using the lifting device, lower the Stellar 10621 just above the crane compartment and start the bolts. Have someone assist in leveling the crane. **Note: the rotation motor should be to the door side of crane compartment and the boom should be extended back over the rear bumper.**
9. Secure the crane using the mounting hardware provided. **Note: longer or shorter cap screws may be required – recommended thread engagement into crane base is 1.75" – use grade 8, zinc plated cap screws only.**
10. Torque the cap screws to 680 ft-lbs.
11. Remove supporting crane.
12. Hook-up hydraulics and electrical using the schematics provided in *Chapter 8 - Hydraulics - Electrical*.
Note: If questions should arise during any portion of this installation, please contact Stellar Customer Service at (800) 321-3741.

WARNING!
 The use of this crane on a body not capable of handling the loads imposed on it may result in serious injury or death.

NOTE:
 STABILITY DECAL P/N 16881
 IS PART OF THIS KIT

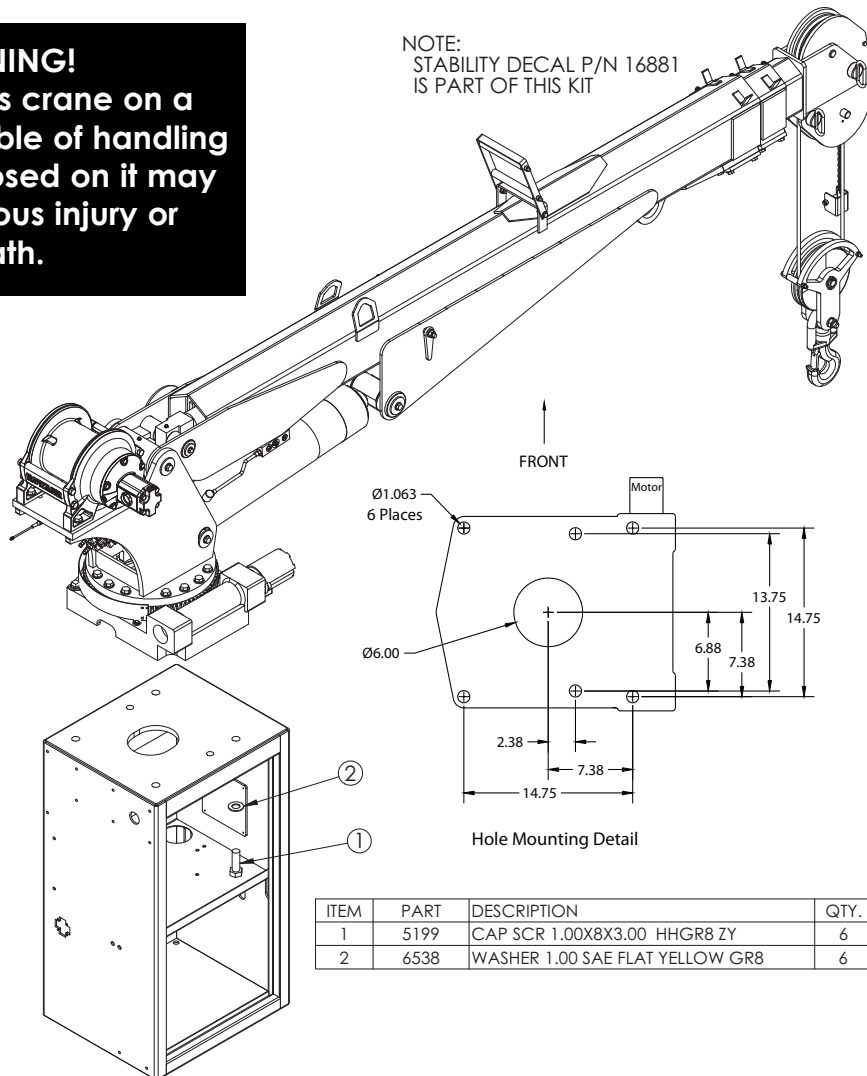

ITEM	PART	DESCRIPTION	QTY.
1	5199	CAP SCR 1.00X8X3.00 HHGR8 ZY	6
2	6538	WASHER 1.00 SAE FLAT YELLOW GR8	6

Control Kit (Flip Sheave Version) - PN 52475

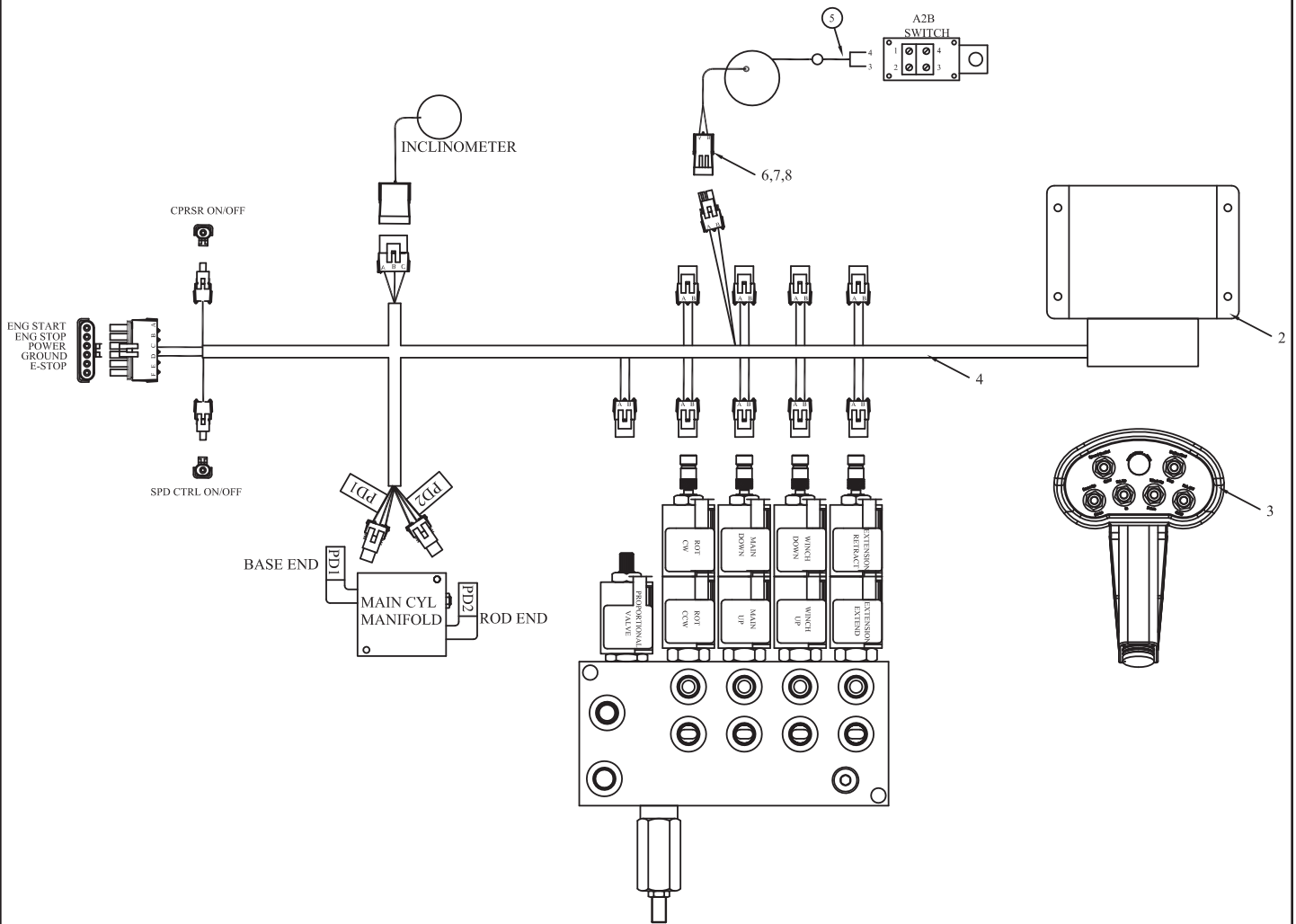

PN 52475

09			
08	10978	CONTACT M/TERM SHROUD	2
07	8384	CABLE SEAL	2
06	9752	CONNECT 2 PIN SHROUD	1
05	10965	CABLE GROMMET	1
04	46307	WIRE HARNESS 12621/12628 LMI	1
03	.	TRANSMITTER · RADIO (PART OF 1)	REF
02	.	RECEIVER · RADIO (PART OF 1)	REF
01	52263	RADIO CONTROLLER ASSEMBLY	1
ITEM	PART No.	DESCRIPTION	QTY

Control Kit (Cradle A2B Version) - PN 52861

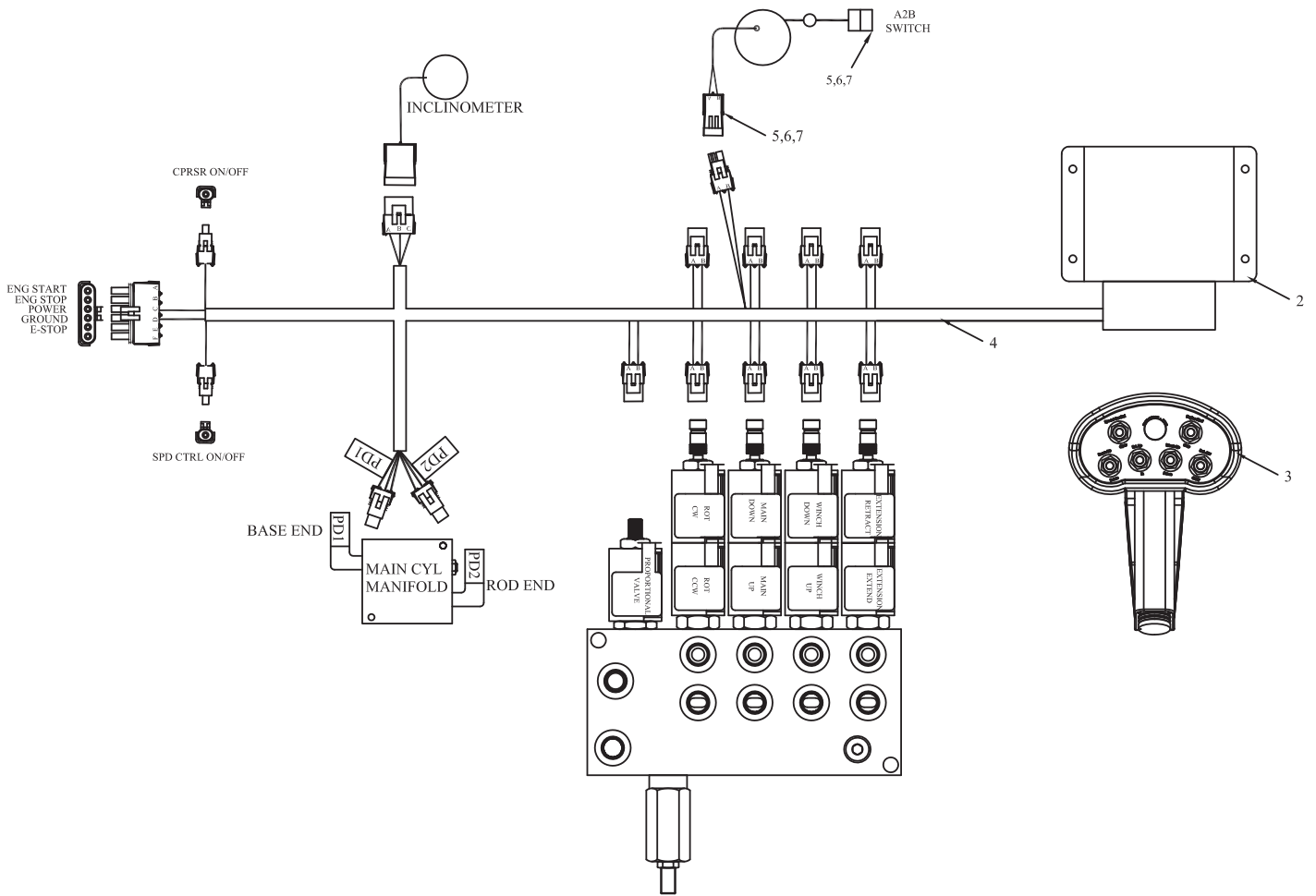

PN 52861

09			
08			
07	8384	CABLE SEAL	4
06	9752	CONNECT 2 PIN SHROUD	2
05	10978	CONTACT M/TERM SHROUD	4
04	46307	WIRE HARNESS 12621/12628 LMI	1
03	.	TRANSMITTER · RADIO (PART OF 1)	REF
02	.	RECEIVER · RADIO (PART OF 1)	REF
01	52263	RADIO CONTROLLER ASSEMBLY	1
ITEM	PART No.	DESCRIPTION	QTY

Control Kit (Flip Sheave/Non-Boost) - PN 56566

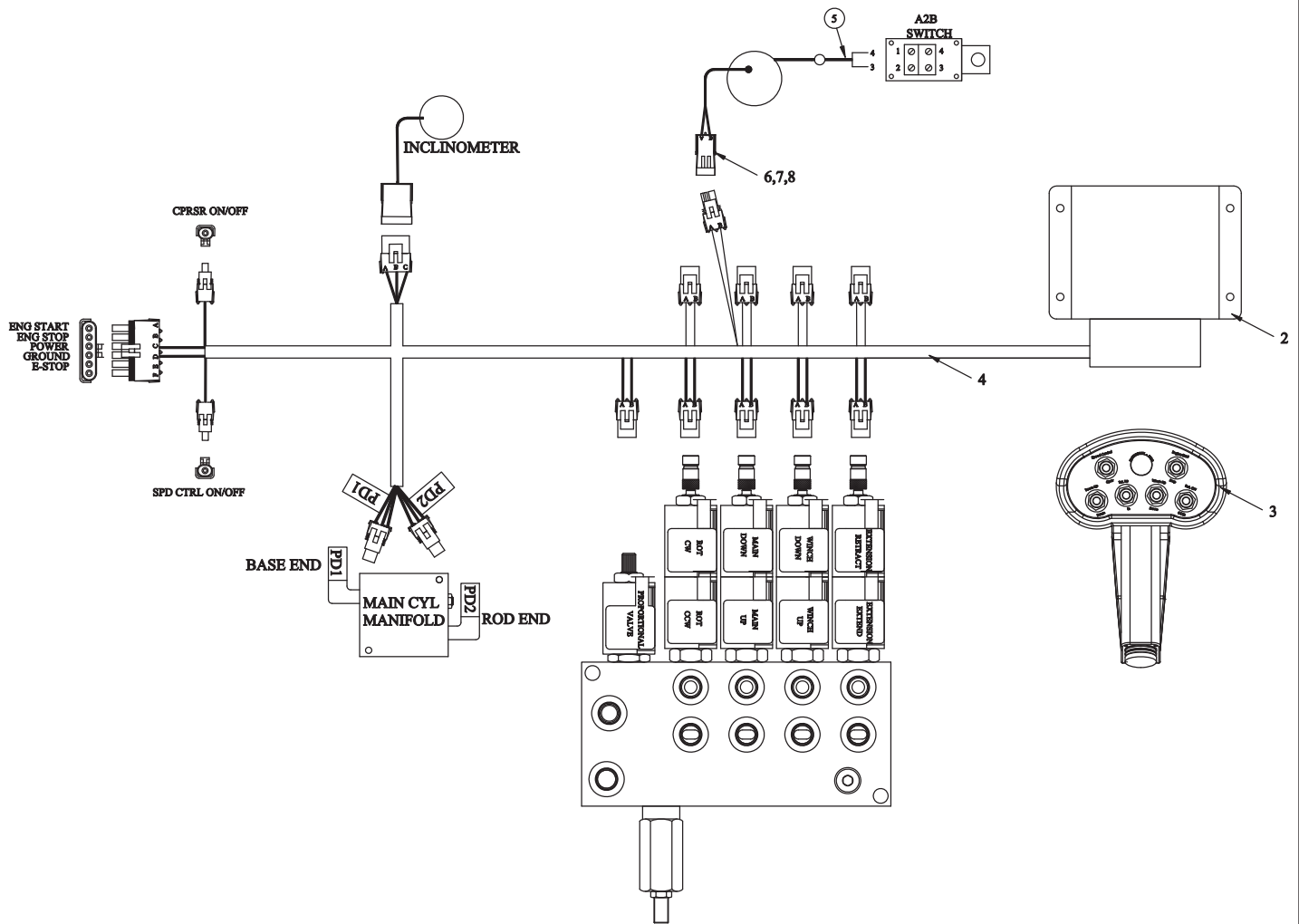

PN 56566

08	10978	CONTACT M/TERM SHROUD	2
07	8384	CABLE SEAL	2
06	9752	CONNECT 2 PIN SHROUD	1
05	10965	CABLE GROMMET	1
04	46307	WIRE HARNESS 12621/12628 LMI	1
03	.	TRANSMITTER - RADIO (PART OF 1)	REF
02	.	RECEIVER - RADIO (PART OF 1)	REF
01	56643	RADIO CONTROLLER ASSEMBLY	1
ITEM	PART No.	DESCRIPTION	QTY

Control Kit (Cradle A2B/Non-Boost) - PN 56642

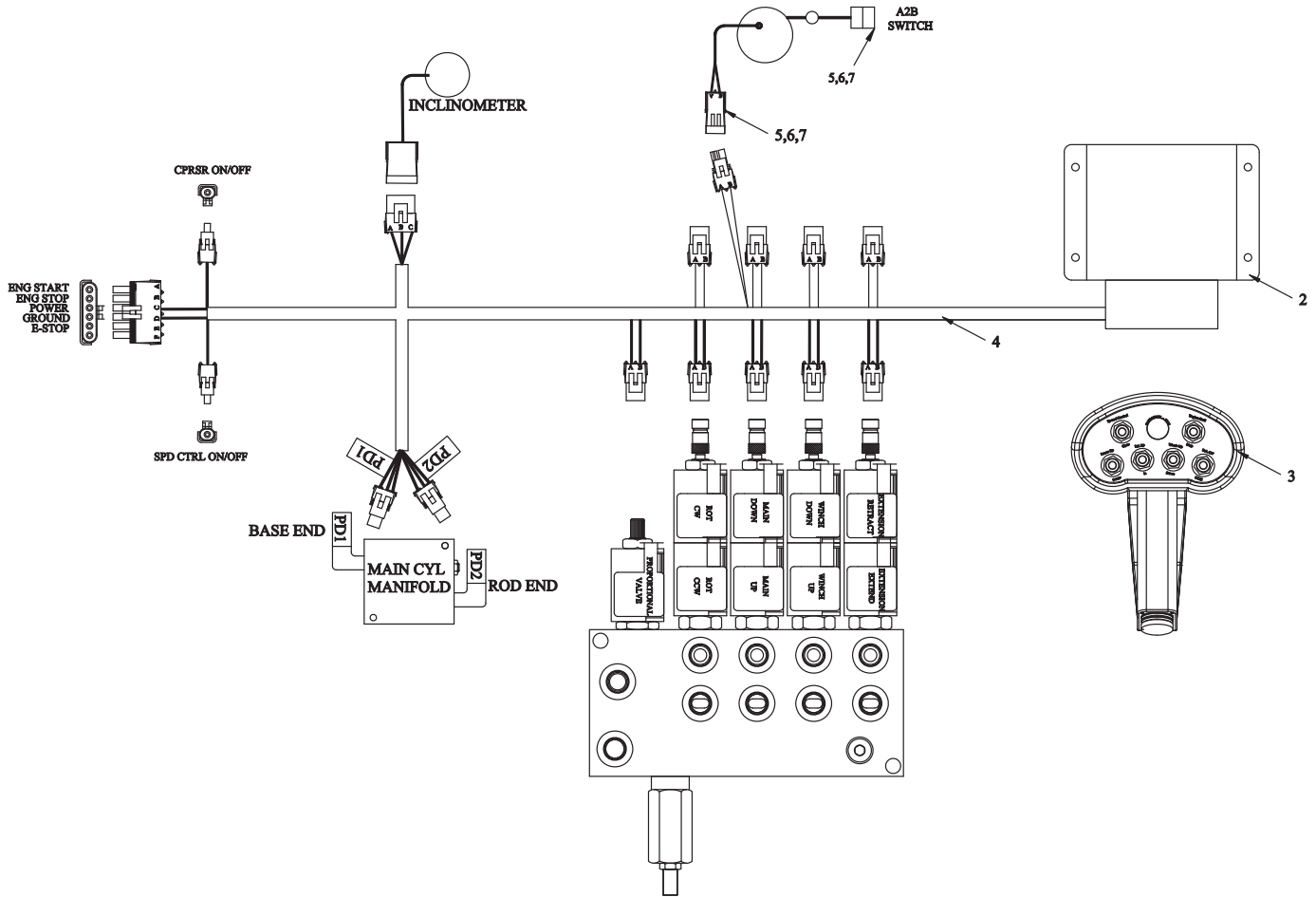

PN 56642

07	8384	CABLE SEAL	4
06	9752	CONNECT 2 PIN SHROUD	2
05	10978	CONTACT M/TERM SHROUD	4
04	46307	WIRE HARNESS 12621/12628 LMI	1
03	.	TRANSMITTER - RADIO (PART OF 1)	REF
02	.	RECEIVER - RADIO (PART OF 1)	REF
01	56643	RADIO CONTROLLER ASSEMBLY	1
ITEM	PART No.	DESCRIPTION	QTY

Hydraulic Kit - PN 52264

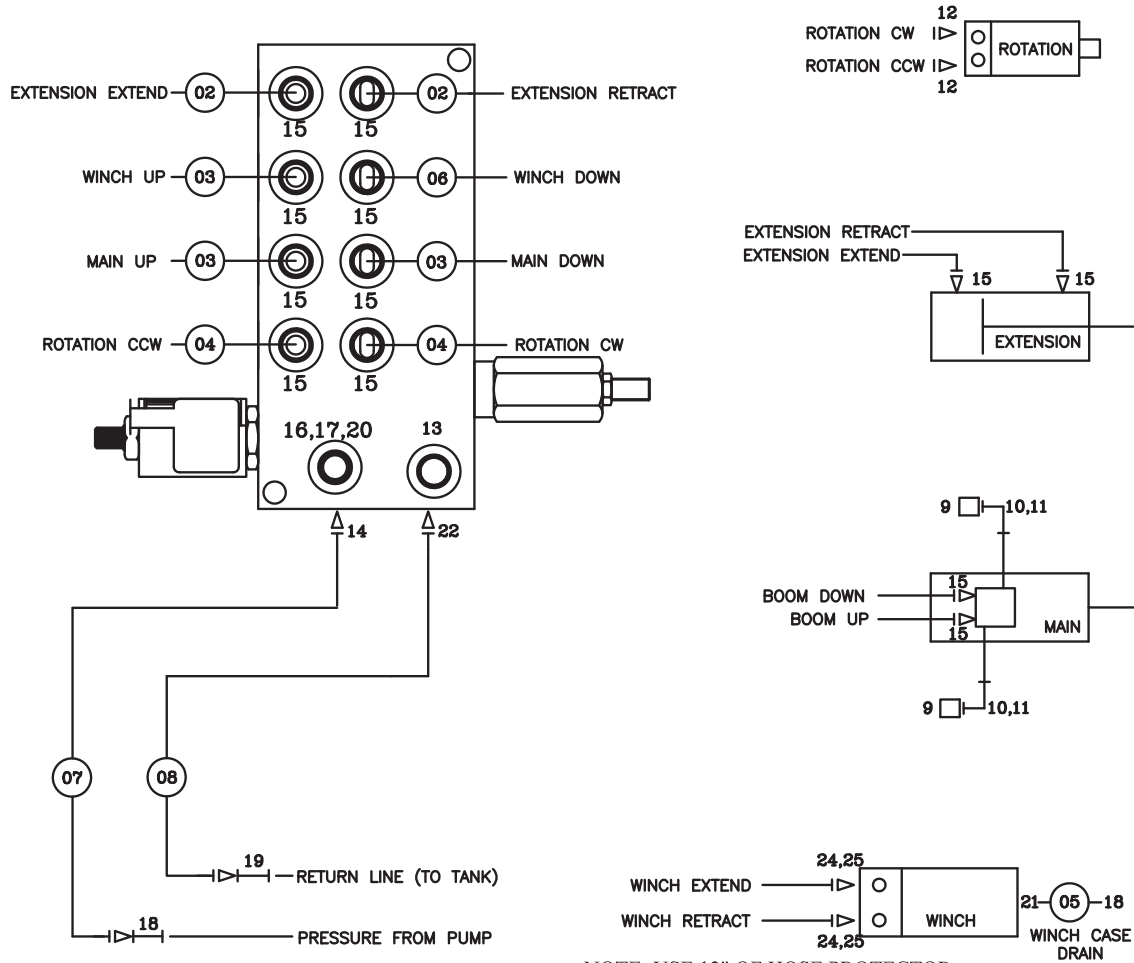

NOTE: USE 12" OF HOSE PROTECTOR
P/N 17288 OVER THE 3 WINCH HOSES

PN 52264

25	C5547	FTG ADAPT 90 6-8 C5OLO-S	2
24	D0549	FTG ADAPT 16-8 F50G5-S	2
23	17288	HOSE PROTECTOR 1.00 AS-B-27	12"
22	C1175	FTG ELL 8-V5OLO-S	1
21	C4929	FTG ADAPT 6-4 F5OLO-S	1
20	D1430	FTG ADAPT O'RING FMP 6-1/4 F50G-S	1
19	12172	FTG SWIVEL 0.50 FS/FS PS81 JMJM-8-8	1
18	12171	FTG SWIVEL 0.38 FS/FS PS81 JMJM-6-6	2
17	6397	GAUGE OIL LF 2.5" 0-5000 CBM	1
16	C5908	FTG 0.25 ML ELL	1
15	0279	FTG ADAPT 6 F5OLO-S	12
14	D1193	FTG ADAPT 6-V5OLO-S	1
13	C4961	PLUG STR HOLLOW HEX 0.38 6-HP50N	1
12	D1302	FTG ADAPT 90 6-10-C5OLO-S	2
11	3861	FTG 90 MSTR/FSTR 6	2
10	15111	FTG ADAPT MSTH/FSTH 6-4-F50G5	2
09	28485	TRANSDUCER PRESSURE 5000 PSI	2
08	45438	HOSE-HYD .50 X 8	1ref
07	45439	HOSE-HYD .38 X 9	1ref
06	52276	HOSE-HYD .38 X 25	1ref
05	28012	HOSE-HYD .38 X 36	1ref
04	13030	HOSE-HYD .38 X 39	2ref
03	13029	HOSE-HYD .38 X 22.50	3ref
02	13028	HOSE-HYD .38 X 17	2ref
01	52267	HOSE KIT12621/12628 (incl:2-8)	1
ITEM	PART No.	DESCRIPTION	QTY

Valve Bank - PN 52265

HYDRAULIC SCHEMATIC

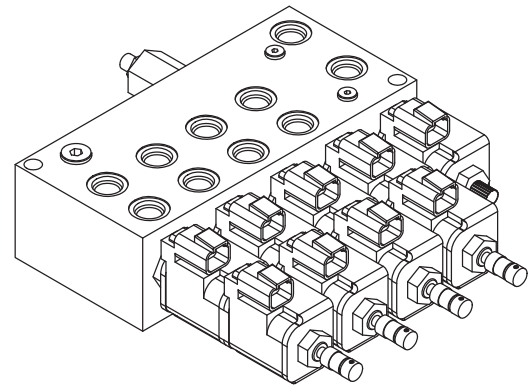
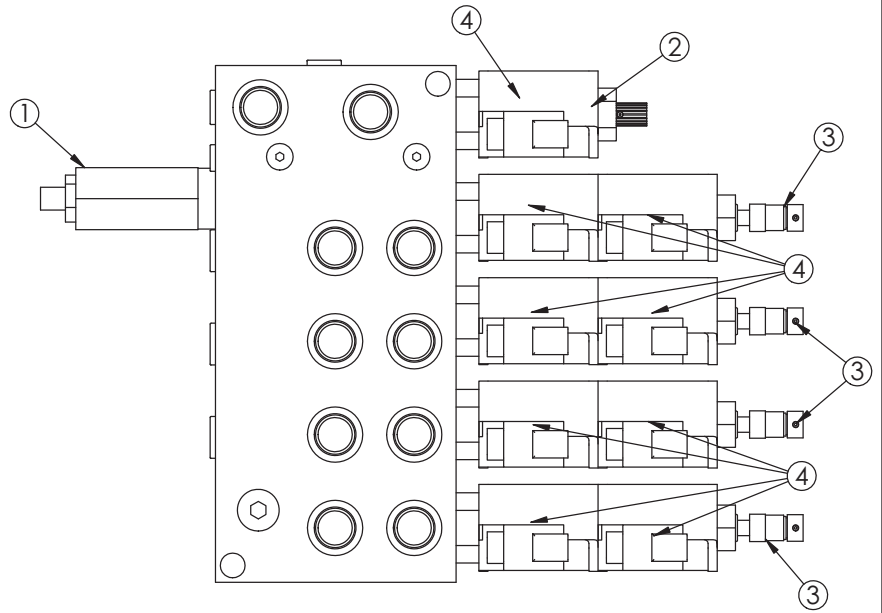
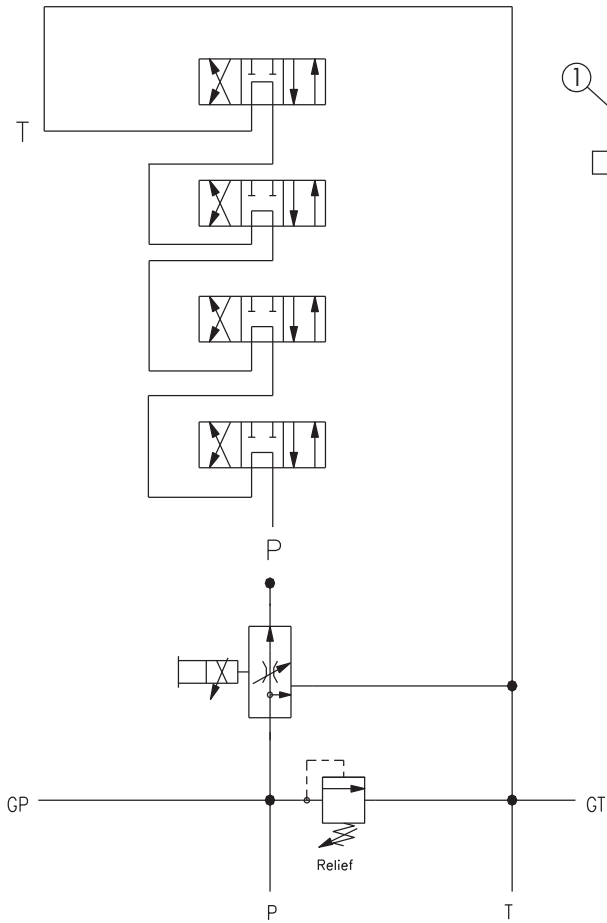

PN 52265

ITEM	PART	DESCRIPTION	QTY
1	25367	RELIEF VALVE 24685/24690	1
	25368	SEAL KIT 25367	
2	24960	VALVE FLW CTRL PRP/JP04C3150N 0-8	1
	25369	SEAL KIT 24960/25381	
3	25371	VALVE SOLND 3 POS 4 WAY TAND G04571	4
	25373	SEAL KIT 25371/25372	
4	44532	COIL 12VDC DUETSCH CAP012H	9

Hydraulic Installation

1. After mounting, locate the pressure and return lines. Note: Pressure line is 3/8" hose; Winch Case Drain Line is 3/8" hose; Return line is 1/2" hose. Hoses are terminated using swivel fittings.
2. Install hydraulic lines per diagram below. See next page for Case Drain Installation. Note: Outrigger valve supplies oil to crane using the Power Beyond feature.
3. Install hydraulic reservoir with return filter. Attach pump pressure line to valve, return link to tank.
4. Fill system with hydraulic oil (See Stellar® Lubrication Recommendations for fluid details).

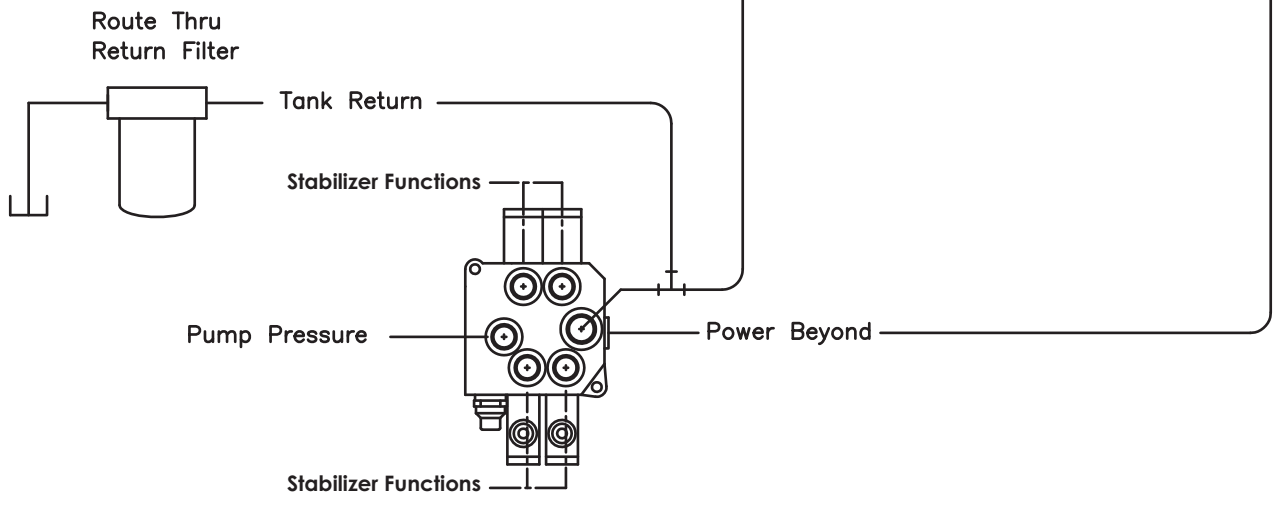
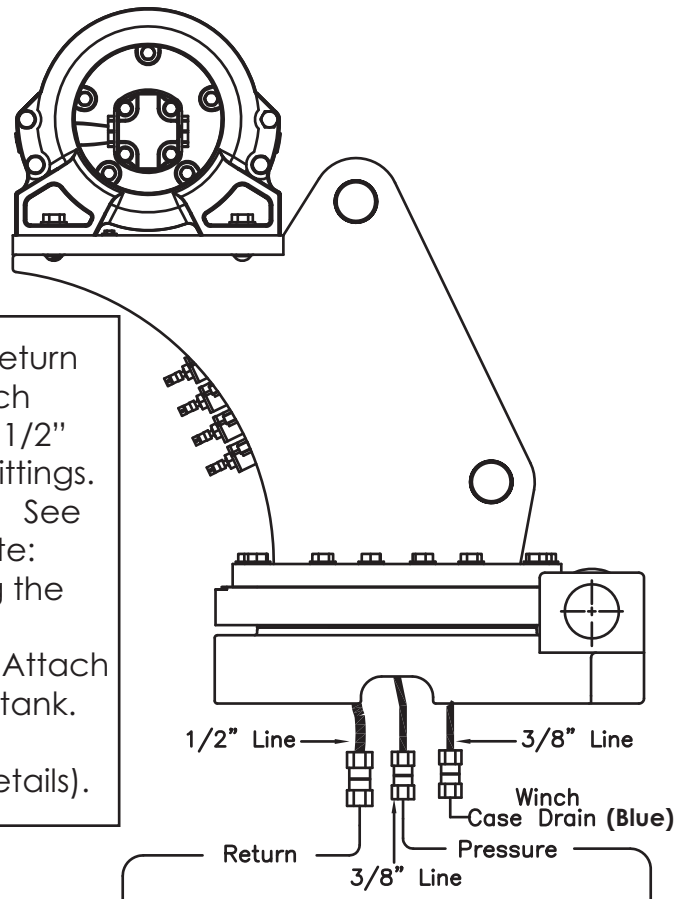

Typical Stabilizer Valve with Power Beyond Capabilities

Winch Case Drain Installation

Installing the winch case drain

1. The winch case drain must run directly to the reservoir to ensure no back pressure in the line.
2. Use 3/8" hydraulic hose and fittings rated for a minimum of 300 psi.
3. Locate the winch case drain line at the bottom of the crane base as shown in Fig. 1 (Blue Hose).
Note: Both the main pressure and winch case drane line use a 3/8" swivel fitting. Verify the winch case drain is attached to the hose that is connected to the winch motor.
4. Attach one end of the winch case drain to 3/8 swivel fitting located in step 3.
5. Route the winch case drain hose directly to the reservoir.
6. Connect the second end of the winch case drain to unshared fitting on the top of the reservoir as shown in Fig 2.

Fig.1

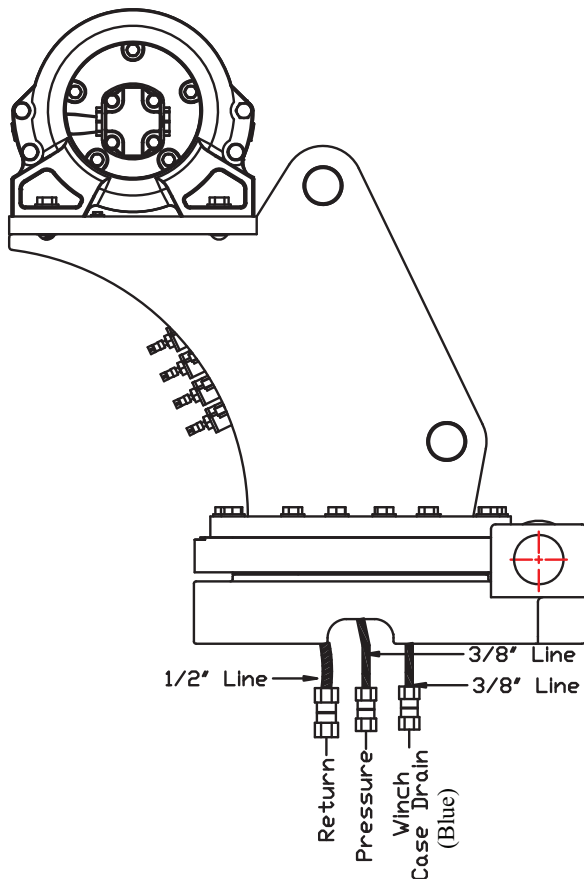
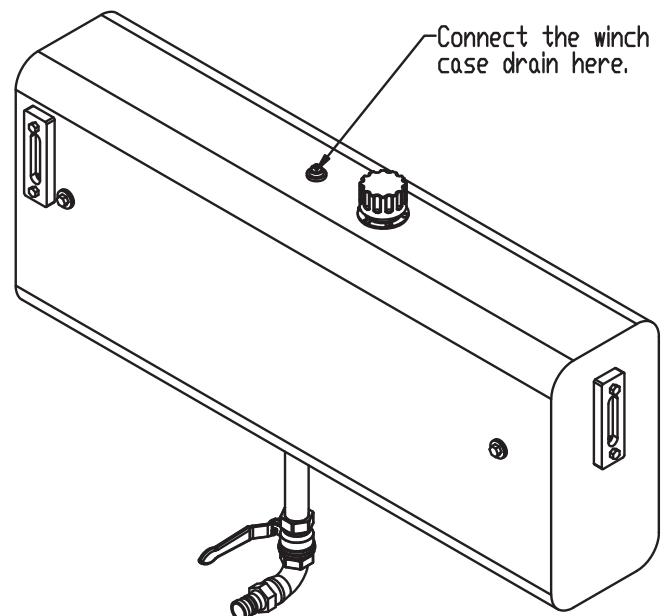
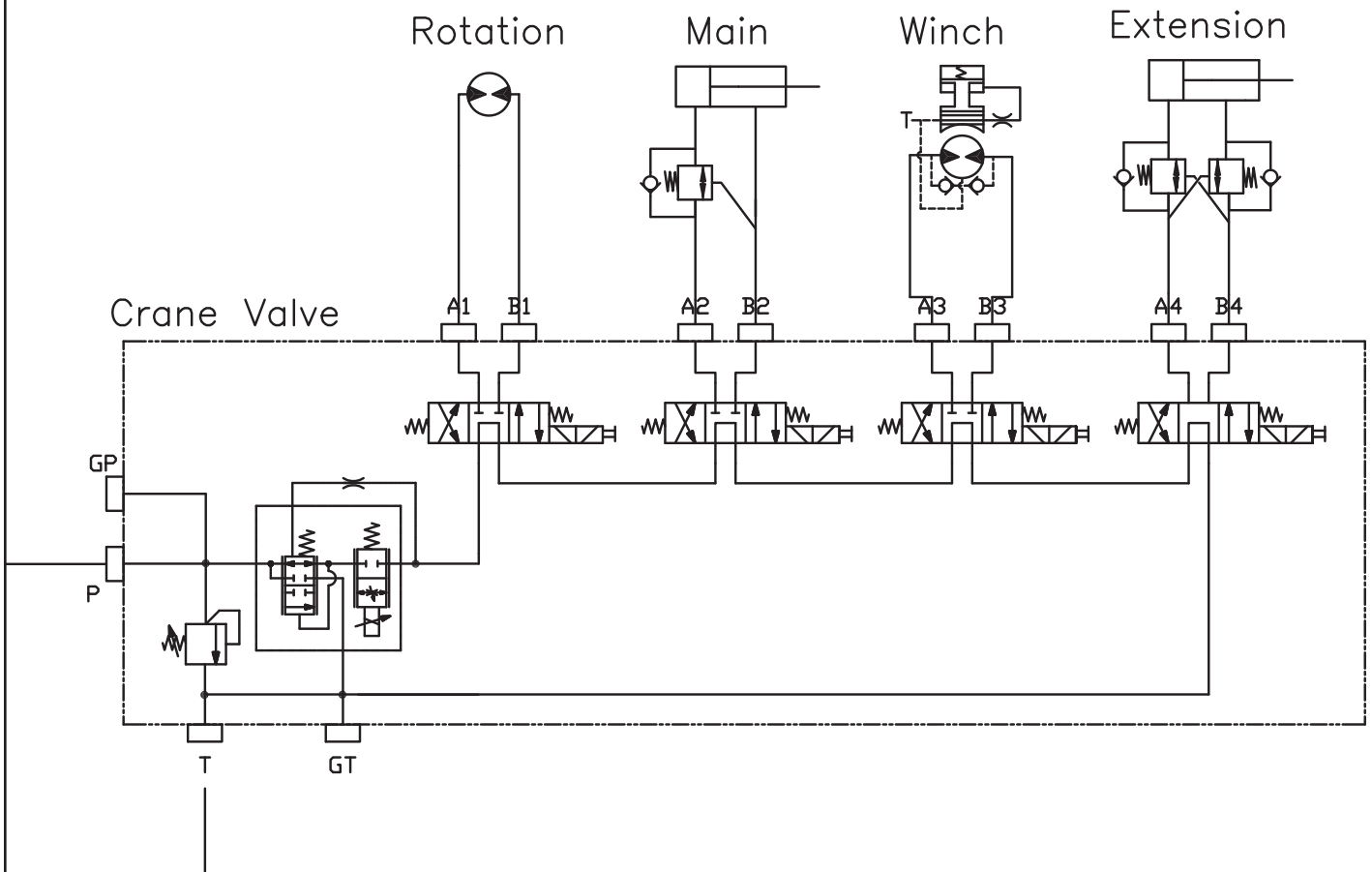

Fig. 2



Hydraulic System



Stability Procedure

Definition of Stability for the Stellar Telescopic Crane Products:

A truck is stable until the load cannot be lifted off the ground with the winch, without tipping over the truck. Every Stellar crane installed must be tested for stability to determine the actual load capacity of the final truck package. The actual test data must be recorded and supplied with the truck at the time of in-service and should be kept with the truck at all times. The following procedure will test the truck package for stability and will provide a stability capacity chart. The load limit information shown on the stability capacity chart is formulated on 85% tipping.

Set Up:

1. Locate the truck on a test course in position for loading and engage travel brakes.
2. Set stabilizers so that they make contact with firm, level footing.
3. Operate the crane under partial load to assure operator proficiency and proper machine function.
4. Put the radio into Stability Test Mode:

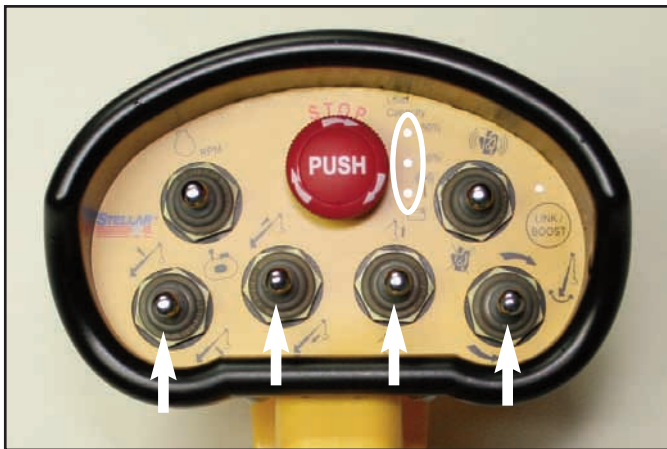

- A. Push the bottom four switches up and hold until all lights come on (approximately 5 seconds.)
- B. At this point, the crane will have enough capacity to handle the weight for the stability test.
- C. The radio will timeout of stability mode after 30 minutes or when the E-Stop button is pushed.

Note: The radio can only be put into stability mode five times. After that, the radio would have to be returned to Stellar to be reprogrammed to allow additional stability testing. All other radio functions will work properly even if stability mode is not available.

10621 Stability Data

Max Horizontal Reach: 252" (From the center of rotation to boom tip)

Boost Stability Test Weight: 3970 lbs.

Non-Boost Stability Test Weight: 3365 lbs.

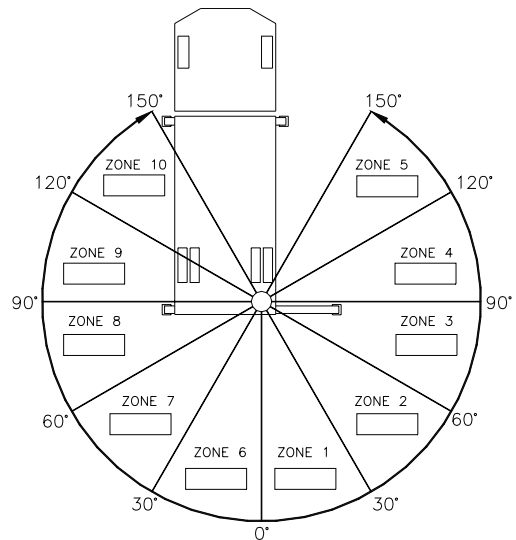

Test Procedure

1. Rotate the crane into Zone 1 position.
2. With the crane fully retracted and the boom horizontal, winch the test weight off the ground. Note: Keep weight within six inches of the ground at all times.
3. Extend the boom outward until full extension has been reached or until the truck becomes unstable (Again, use the winch to keep the weight within six inches of the ground.)
4. If the boom goes full extension without becoming unstable, the crane is termed stable for this zone and 100% can be written in the Zone 1 data box.
5. If the truck becomes unstable prior to going full extension, retract the boom until the truck becomes stable and measure the horizontal reach in this position (center of rotation to boom tip). This is the stable horizontal reach for this zone. Stable horizontal reach divided by Maximum horizontal reach multiplied by 100 equals the percentage of rated capacity for this zone. Use the following formula to determine the percentage of rated capacity:

$$\frac{\text{Stable Horizontal Reach}}{\text{Max Horizontal Reach}} \times 100 = \text{Percentage of Rated Capacity}$$
6. Record this number in the data box for Zone 1. This is the revised capacity due to stability for this zone.
7. Repeat this procedure for each zone until the worksheet is completed.
8. This is the revised capacity based on stability of this package.

Decal Kit Placement - PN 54761

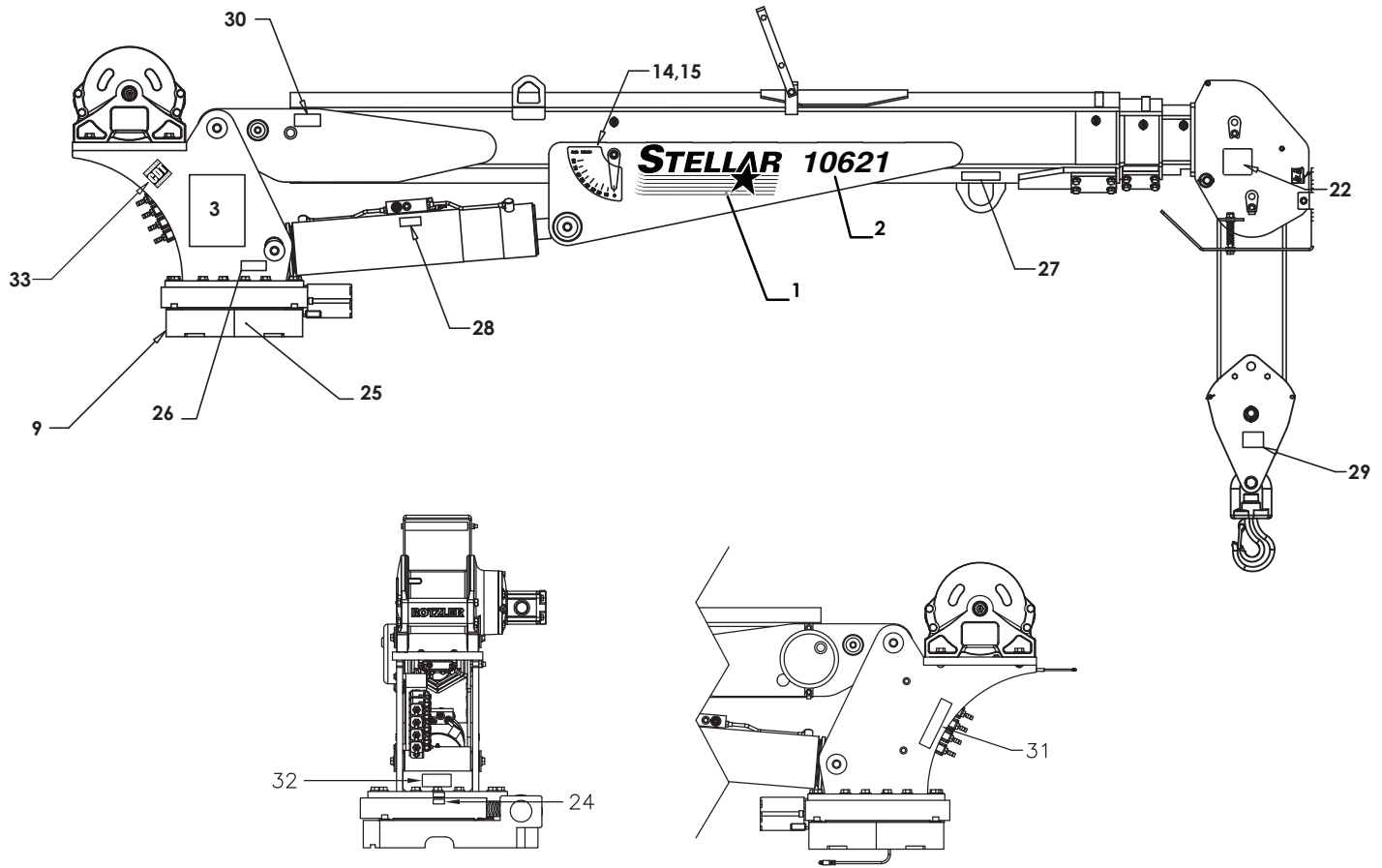

PN 54761

**THESE DECALS NOT INCLUDED WITH THE DECAL KIT

*USE THESE DECALS WITH BODY PACKAGE

ITEM	PART No.	DESCRIPTION	QTY	ITEM	PART No.	DESCRIPTION	QTY
				33	54588	DECAL CDT 2.00X2.00	2
*16	12451	DECAL HOISTING PERSONNEL	1	32	25159	DECAL WARNING MANUAL OVERRIDES	1
15	D1197	DECAL-ANGLE INDICATOR SS	1	31	52270	DECAL VB CONTROL MECH CRANE	1
14	D1196	DECAL ANGLE INDICATOR CS	1	30**	35234	DECAL STELLAR MADE IN THE USA	1
*13	C1179	DECAL-ELECTROCUTION 4.5x7.5	2	29	56405	DECAL SNATCH BLOCK CAP 7 TON	1
*12	C5918	DECAL-DANGER MOVING O.R.	2	28	28256	DECAL WARNING OVERLOAD DEVICE	1
*11	C4795	DECAL-DANGER O.R.	2	27	24712	DECAL CAUTION STOW HOOK	1
*10	4190	DECAL-DANGER	1	26	15172	DECAL ASME/ANSI B30.22/B30.5	1
09	9188	DECAL-ROTATE/GREASE	1	25	15171	DECAL GREASE WORM DRIVE BEARINGS	1
*08	4189	DECAL-DANGER	1	24	4188	DECAL-ROTATION ALIGNMENT	1
*07	4186	DECAL-ELECTROCUTION 2x2.75	1	*23	C4541	DECAL-CRANE STOWING	1
*06	C4544	DECAL-DANGER	1	22	12300	DECAL-TWO BLOCKING	1
*05	C4540	DECAL-DANGER	1	*21	4214	DECAL-SERVICE	1
*04	C4545	DECAL-ELECTROCUTION 5x13	4	*20	C0568	DECAL-DIESEL	2
*03	54622	DECAL CAPACITY	2	*19	12452	DECAL MANUAL EXT	1
02	52686	DECAL 10621 IDENTIFICATION	2	*18	C5911	DECAL-STELLAR 2x4.5	3
01	52681	DECAL STELLAR LOGO 6.5 x 18	2	*17	C5910	DECAL-STELLAR 4x9.5	1

Chapter 3 - Assembly Drawings

Base Assembly - PN 18027

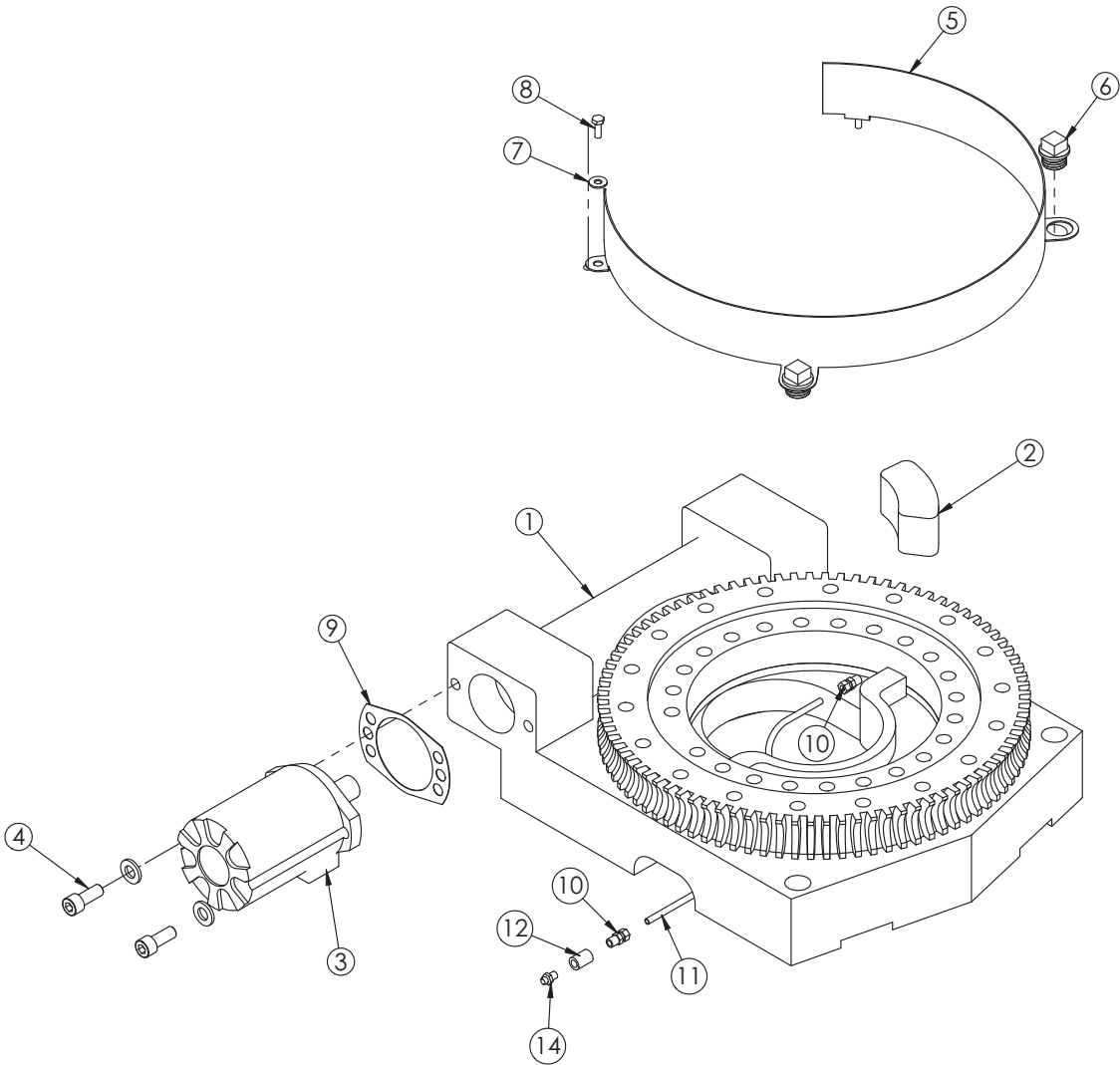

PN 18027

ITEM	PART	DESCRIPTION	QTY.
1	11453	BEARING SWING DRIVE CAST BASE 6620	1
2	11542	STOP 3820 400 SLIDE	1
3	C6069	MOTOR HYD ROSS MK080613AAAB	1
4	D1307	CAP SCR 0.50-13X1.25 SH	2
5	44551PC	GUARD TTB 6620 CRANE LZR	1
6	13959	CAP SCR 1.00-8 X .63 PLASTIC	2
7	0340	WASHER 0.25 FLAT	2
8	0479	CAP SCR 0.25-20X0.75 HHGR5	2
9	21151	GASKET MOTOR 008-10056-1	1
10	D1345	FTG CPRSN 0.12NPT/0.25 TUBE	2
11	D1810	TBE AIR SAEJ844 TYPE A .25 (RM)	1
12	C2256	FTG COUPLER PIPE 0.13	1
13	D0790	WASHER 0.50 FLAT GR8	2
14	56589	ZERK 1/8 NPT STRAIGHT LONG THREAD	1

GASKET SHOWN AS REFERENCE

Mast Assembly - PN 52488

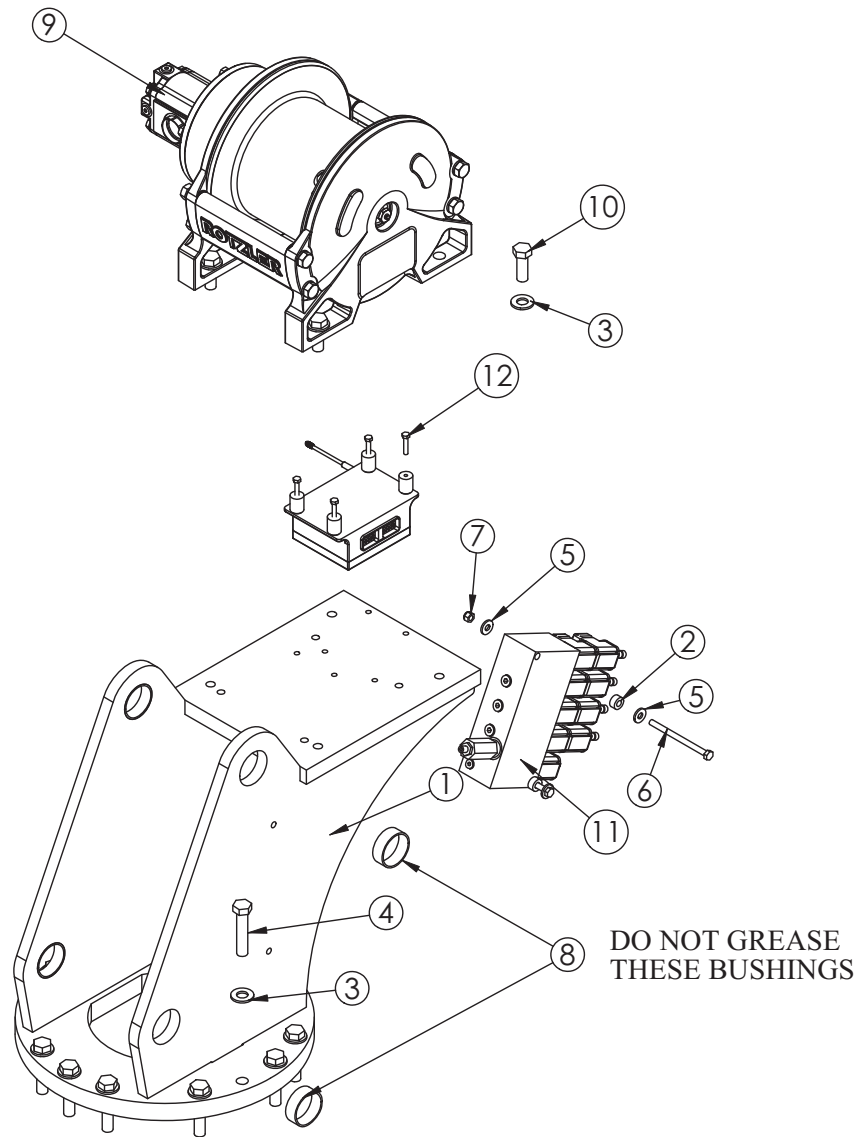

PN 52488

ITEM	PART	DESCRIPTION	QTY.
1	43483	MAST 10621/12621	1
2	27813	COLLAR 0.38X0.75X0.38 UHMW	2
3	C5902	WASHER 0.63 SAE FLAT YELLOW GR8	18
4	D1034	CAP SCR 0.63-11X3.00 HHGR8	14
5	0343	WASHER 0.31 USS FLAT ZINC	4
6	C0933	CAP SCR 0.31-18X4.50 HHGR5	2
7	0342	NUT 0.31-18 HHGR5 NYLOC	2
8	44533	BUSHING HSG3235012S 2.00X0.75	4
9	41547	WINCH 5000 TH2CC00243	1
10	11693	CAP SCR 0.63-11X1.75 HHGR8	4
11	52265	VB 4 SECT W/PROP STER8GPM DEUTSCH	1
12	52490	CAP SCR 6MMX30MM HH CLASS 8.8	4

Main Boom - PN 52489

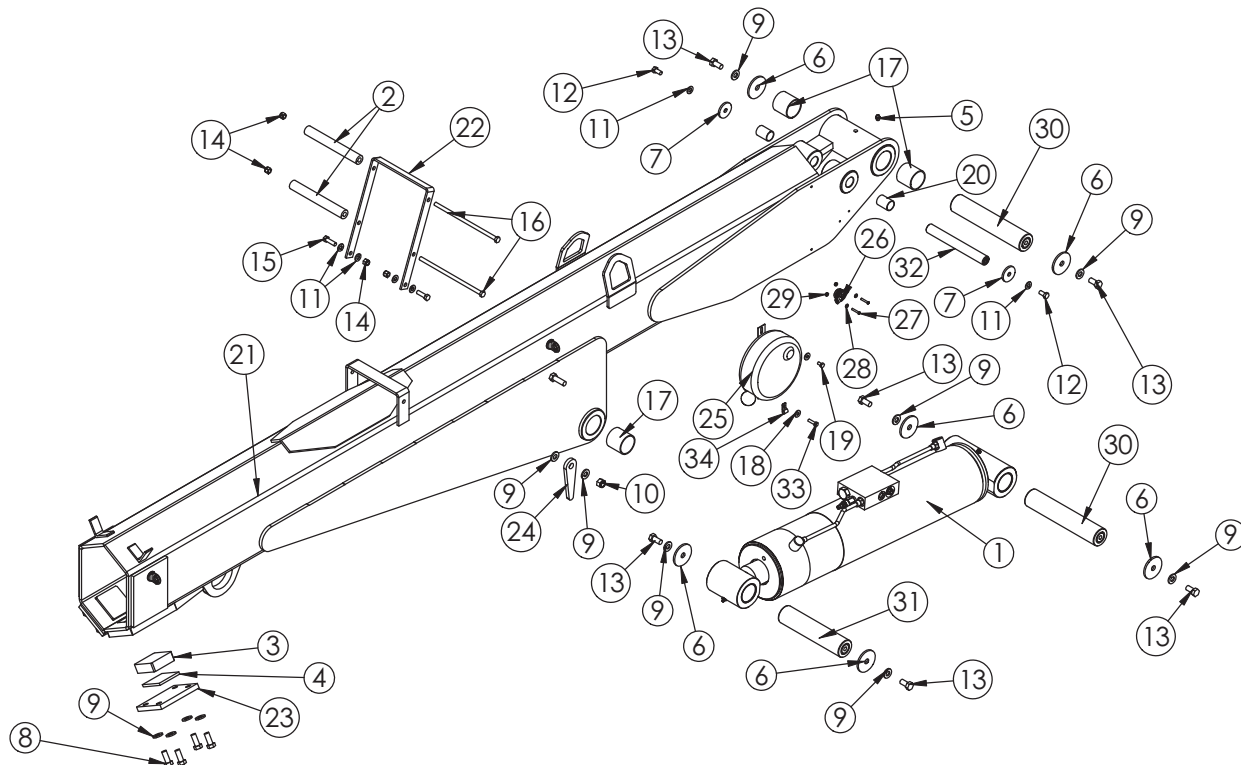

PN 52489

ITEM	PART	DESCRIPTION	QTY.	ITEM	PART	DESCRIPTION	QTY.
1	43839	CYLINDER ASM 5.50X21.38	1	17	4381	BUSHING BPC32DXR32 2.00X2.00	4
2	27720	SPACER ROPE GUIDE 6620 UHMW	2	18	0340	WASHER 0.25 USS FLAT ZINC	2
3	13395	WEAR PAD 3.00X3.00X1.00 NYLATRON	2	19	0478	CAP SCR 0.25-20X0.50 HHGR5	1
4	35451	PLATE AL 0.25X2.88X2.88	2	20	0068	BUSHING BPC16DXR24 1.00X1.50	2
5	c1592	ZERK 1/8 NPT STRAIGHT	1	21	43476	INNER BOOM 10621/12621	1
6	9142	PIN CAP 0.56X2.50X0.19	6	22	13435PC	BRKT ROPE GUIDE 9620	1
7	9320	PIN CAP 0.44X1.75X0.19 SS	2	23	13398PC	PLATE WEAR PAD SUPPORT 9620	2
8	10666	CAP SCR 0.50-13X1.25 HHGR8	8	24	D1194PC	PLATE ANGLE INDICATOR	2
9	D0790	WASHER 0.50 SAE FLAT YELLOW GR8	18	25	11544	CORD REEL 6620	1
10	C6106	NUT 0.50-13 HHGR5 NYLOC	2	26	53493	INCLINOMETER 60 DEG	1
11	C6353	WASHER 0.38 SAE FLAT YELLOW GR8	6	27	18618	SCREW #6-32X1.00 PHMS PH	2
12	9843	CAP SCR 0.38-16X0.75 HHGR8	2	28	18765	WASHER #6 SAE FLAT ZINC	2
13	10172	CAP SCR 0.50-13X1.00 HHGR8	6	29	D0076	NUT #6-32 HH NYLOC SS	2
14	0347	NUT 0.38-16 HHGR5 NYLOC	4	30	9709ZP	PIN 2.00X10.19 D&T	2
15	0335	CAP SCR 0.38-16X1.25 HHGR5	2	31	9711ZP	PIN 2.00X8.88 D&T	1
16	12168	CAP SCR 0.38-16X9.00 HHGR5	2	32	9712ZP	PIN 1.00X8.38 D&T	1
				33	0480	CAP SCR 0.25-20X1.00 HHGR5	1
				34	C5606	CLAMP 0.25 BLK VINYL	1

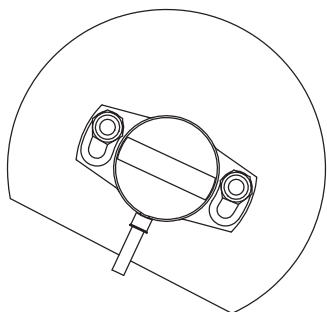

NOTE: INCLINOMETER MOUNTS
INSIDE THE BOOM. VIEW SHOWS
POSITION OF INCLINOMETER

Extension Boom Assembly - PN 41546

PN 41546

ITEM	PART	DESCRIPTION	QTY.
1	9991	WEAR PAD 0.19X2.50 RND NYLATRON	4
2	27719	SPACER BOOM TIP 6620 UHMW	2
3	12824	PIN HITCH 1.00X4.50	1
4	5753	PIN 0.19X1.56 LYNCH	1
5	13396	WEAR PAD 2.50X2.50X1.00 NYLATRON	2
6	27710	SPRING ANTI 2 BLOCK SUMMIT	2
7	31132	SCREW #10-24X0.50 SH SS	2
8	D0178	WASHER #10 SAE FLAT ZINC	2
9	31279	CLAMP 0.31 BLK VINYL	1
10	35105	SWITCH LIMIT E1117-B9111-6C	1
11	35452	PLATE AL 0.25X2.38X2.38	2
12	43858	SHEAVE 10621 9.25 DIA. .44R/1.88THK	2
13	43488PC	PLATE CRADLE 10621/12621	1
14	D0790	WASHER 0.50 SAE FLAT YELLOW GR8	16
15	10666	CAP SCR 0.50-13X1.25 HHGR8	8
16	0490	CAP SCR 0.31-18X3.50 HHGR5	2
17	0342	NUT 0.31-18 HHGR5 NYLOC	2
18	0343	WASHER 0.31 USS FLAT ZINC	2
19	0420	CAP SCR 0.31-18X0.75 HHGR5	2
20	0507	CAP SCR 0.50-13X4.50 HHGR5	1
21	C6106	NUT 0.50-13 HHGR5 NYLOC	3
22	C6219	WASHER 0.75 SAE FLAT YELLOW GR8	1
23	58681	CAP SCR 0.75-10X2.50 HHGR8	1
24	34740	EXT BOOM 10620 1ST	1
25	43479	EXT BOOM 2ND 10621/12621	1
26	28859	CYLINDER EXT ASM 9620 13980P	1
27	13397PC	PLATE 1ST EXT 9620 WEAR PAD	2
28	C1000	CAP SCR 0.50-13X5.00 HHGR5	2
29	13399ZP	PIN TEAR DROP 1.00X3.81	2

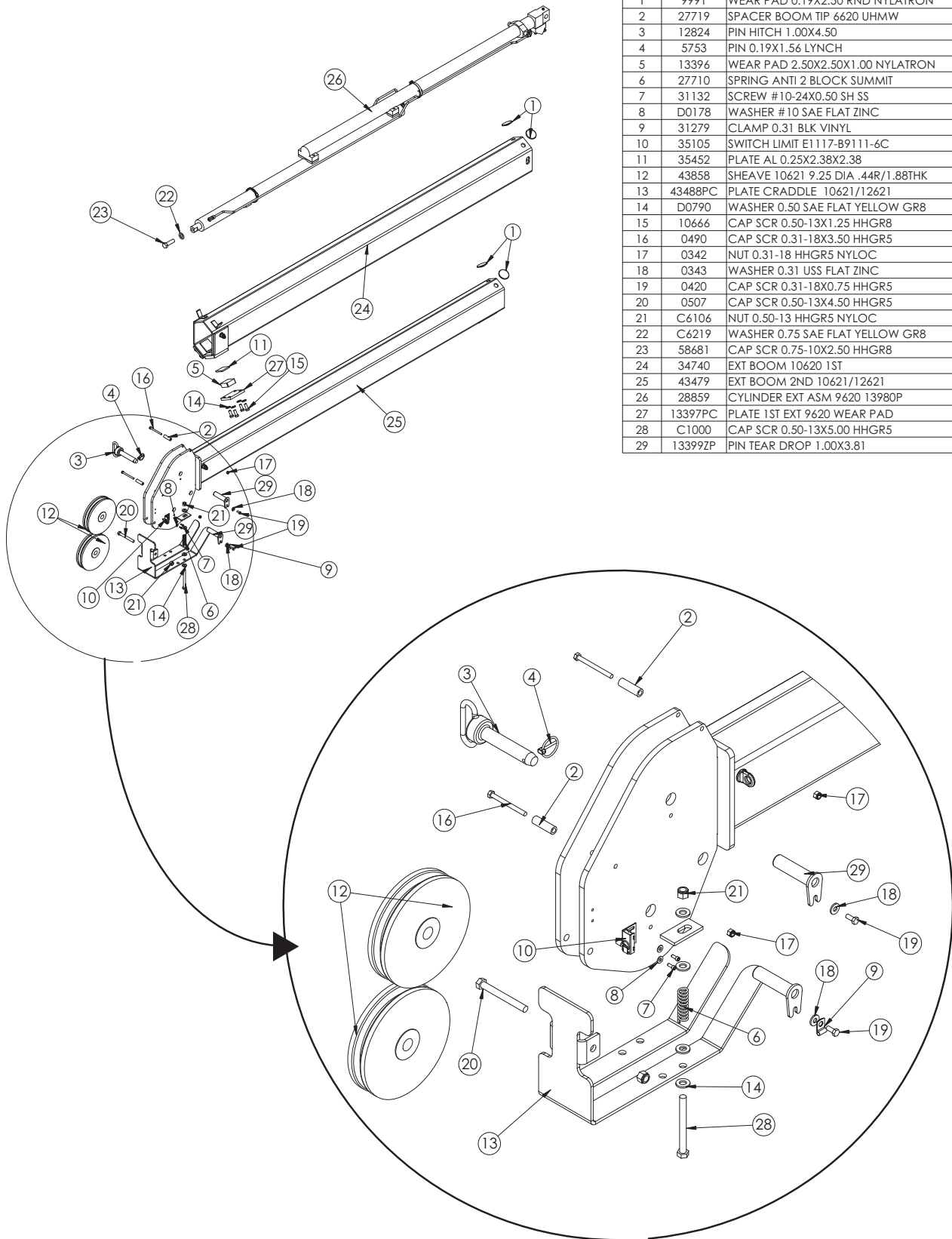

Extension Boom Assembly Flip Sheave - PN 46309

OPTIONAL

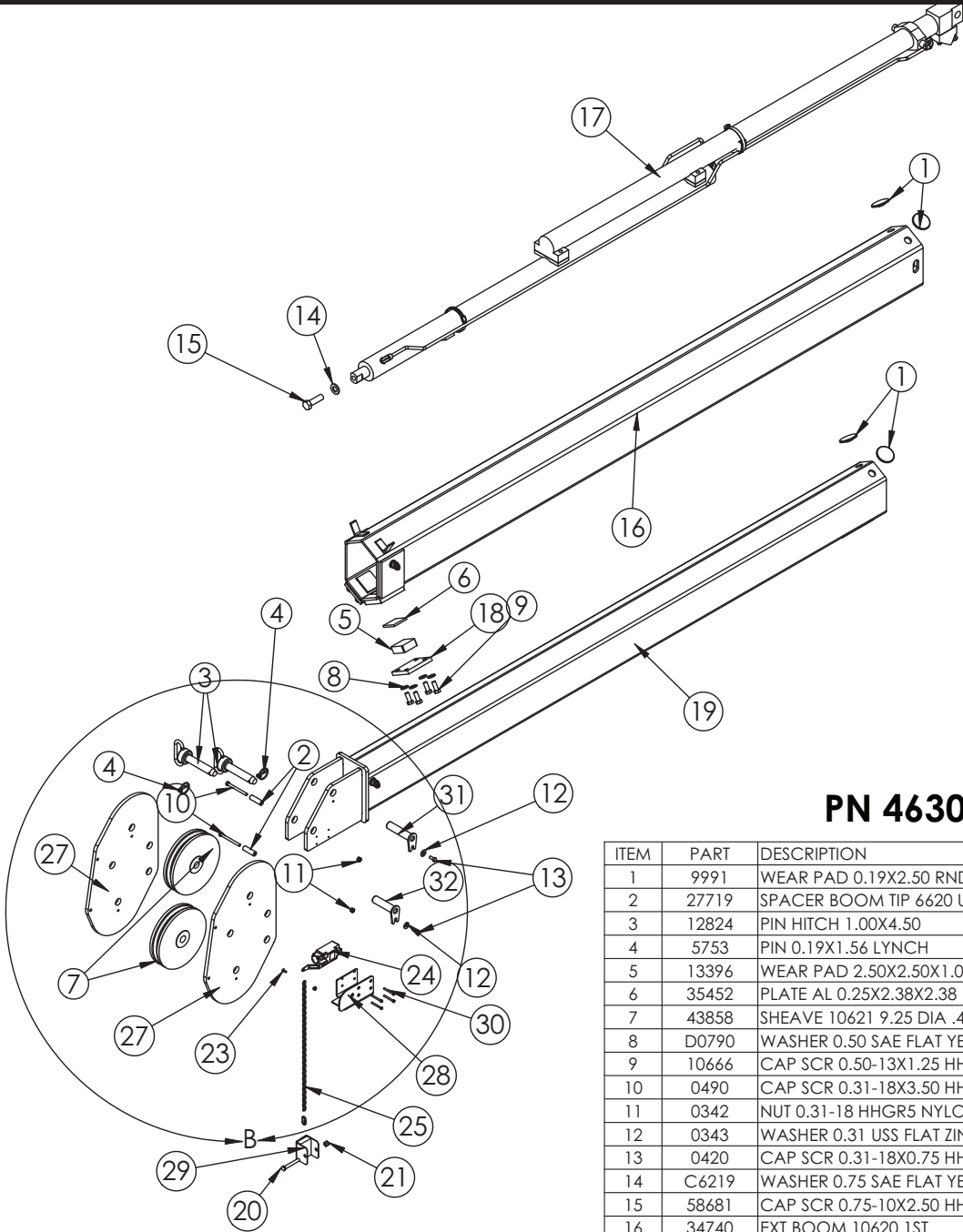

PN 46309

ITEM	PART	DESCRIPTION	QTY.
1	9991	WEAR PAD 0.19X2.50 RND NYLATRON	4
2	27719	SPACER BOOM TIP 6620 UHMW	2
3	12824	PIN HITCH 1.00X4.50	2
4	5753	PIN 0.19X1.56 LYNCH	2
5	13396	WEAR PAD 2.50X2.50X1.00 NYLATRON	2
6	35452	PLATE AL 0.25X2.38X2.38	2
7	43858	SHEAVE 10621 9.25 DIA .44R/1.88THK	2
8	D0790	WASHER 0.50 SAE FLAT YELLOW GR8	8
9	10666	CAP SCR 0.50-13X1.25 HHGR8	8
10	0490	CAP SCR 0.31-18X3.50 HHGR5	2
11	0342	NUT 0.31-18 HHGR5 NYLOC	2
12	0343	WASHER 0.31 USS FLAT ZINC	2
13	0420	CAP SCR 0.31-18X0.75 HHGR5	2
14	C6219	WASHER 0.75 SAE FLAT YELLOW GR8	1
15	58681	CAP SCR 0.75-10X2.50 HHGR8	1
16	34740	EXT BOOM 10620 1ST	1
17	28859	CYLINDER EXT ASM 9620 13980P	1
18	13397PC	PLATE 1ST EXT 9620 WEAR PAD	2
19	46310	EXT BOOM 2ND 10621/12621 FLIP SHEAVE	1
20	0530	CAP SCR 0.38-16X2.75 HHGR5	1
21	0347	NUT 0.38-16 HHGR5 NYLOC	1
22	C4956	NUT #10-24 HH NYLOC SS	1
23	D1711	CAP SCR #10-24X0.50 BTNHD SS	1
24	11938	SWITCH LIMIT A2B FURNAS 3SE3170	1
25	18454	CHAIN 0.105X21.50	1
26	37850	CONNECTOR QUICK LINK 0.13	1
27	15998PC	PLATE SHEAVE MOUNTING 10620	2
28	34354PC	ANTI 2 BLOCK COVER LH	1
29	35264PC	WEIGHT ANTI 2 BLOCK	1
30	33749	CAP SCR #10-24X1.75 SH	4
31	13400ZP	PIN TEAR DROP 1.00X4.38	1
32	13399ZP	PIN TEAR DROP 1.00X3.81	1

Main Cylinder Assembly - PN 43839

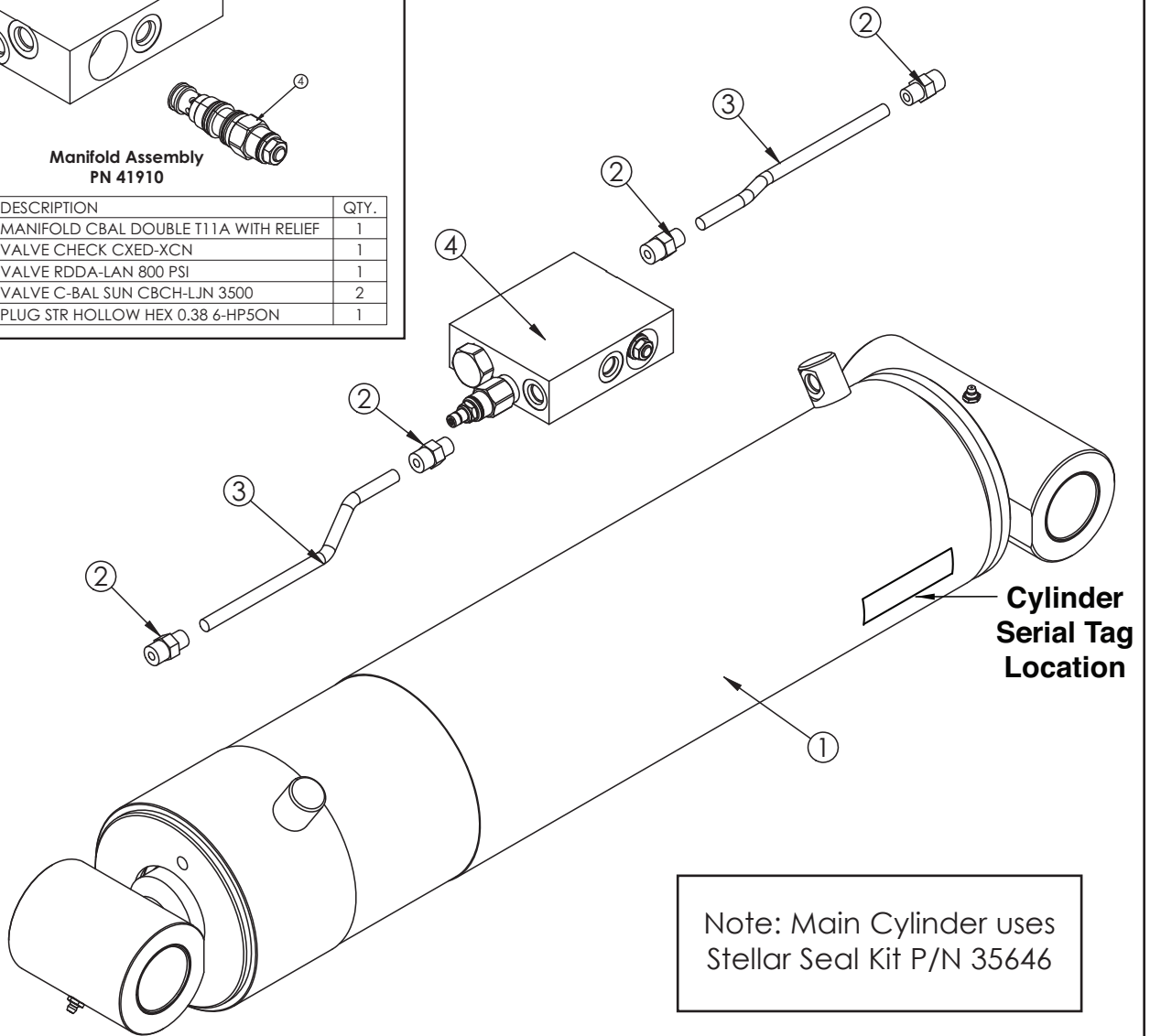
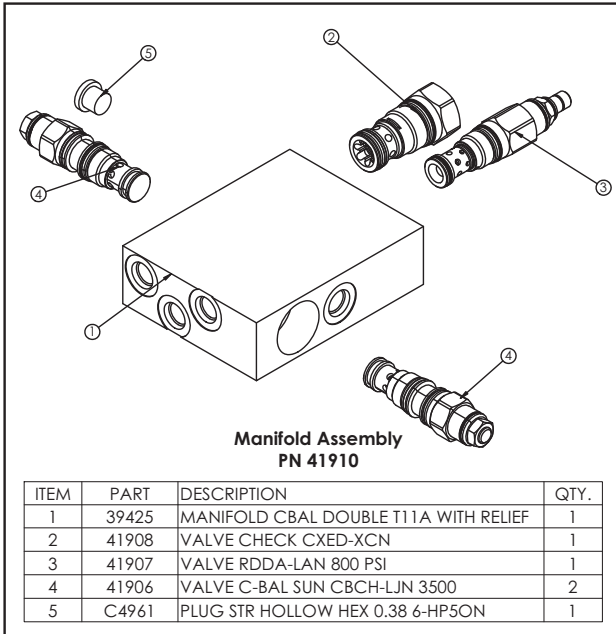

PN 43839

ITEM	PART	DESCRIPTION	QTY.
1	43838	CYLINDER 5.50X21.38	1
2	0279	FTG ADAPT 6-F5OLO-S	4
3	44066	TUBE ASM 0.38X8.25 MAIN 10628/12628	2
4	41910	MANIFOLD ASM DUAL 10-1CBAL-RLF-CHK	1

Extension Cylinder Assembly - PN 28859

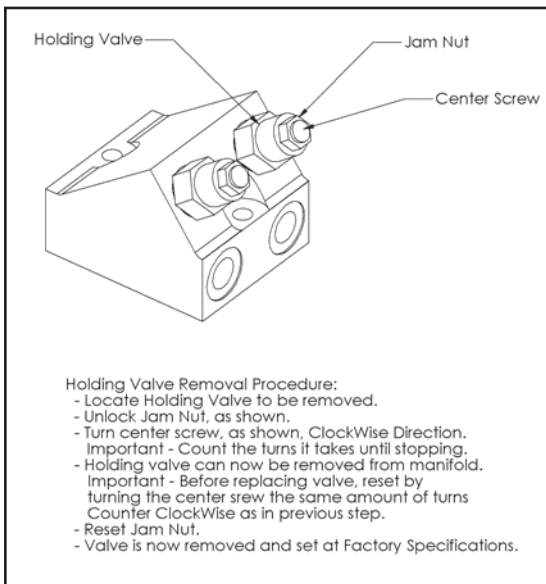
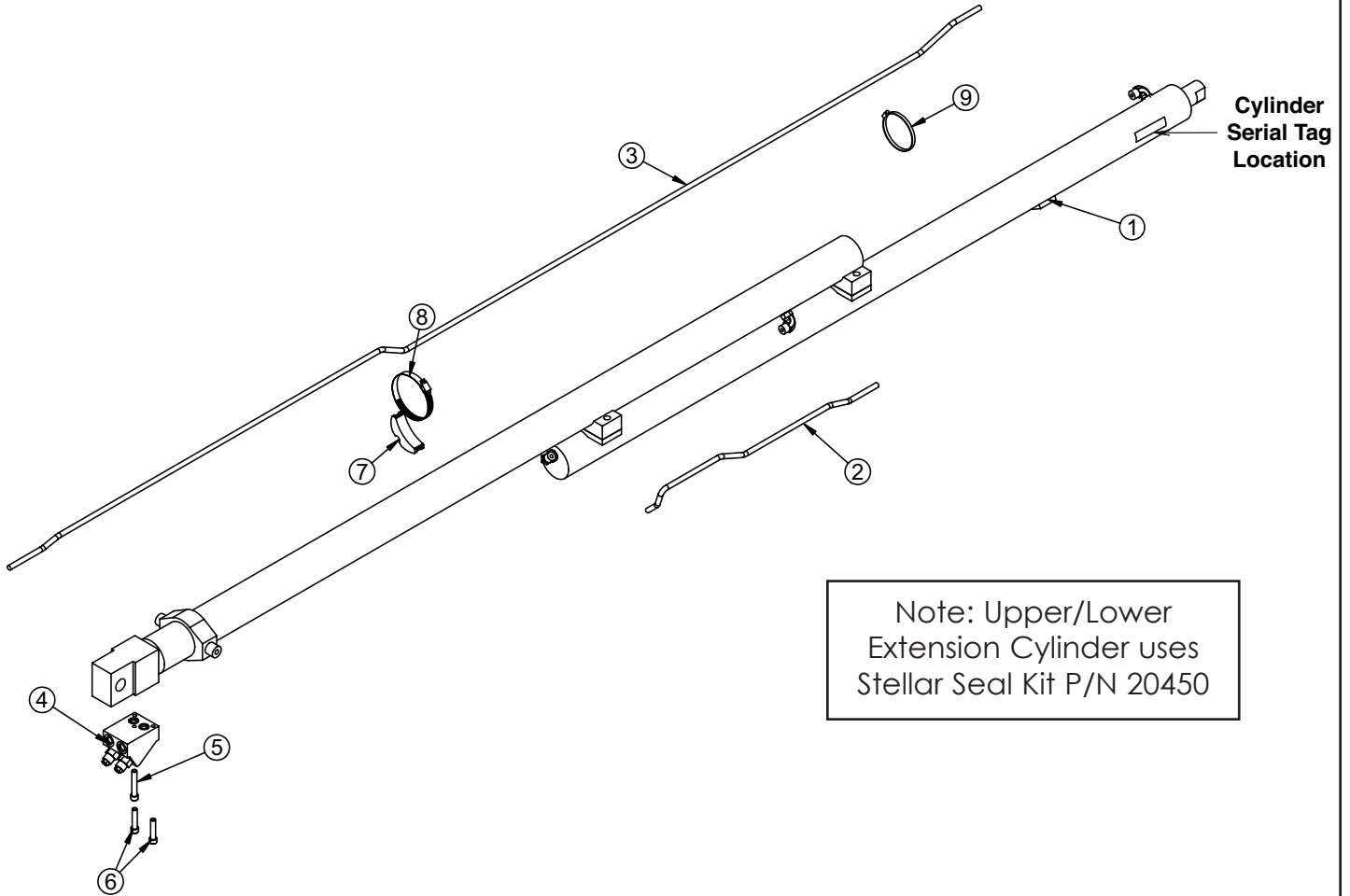

P/N 28859

ITEM	PART	DESCRIPTION	QTY.
1	13980P	CYLINDER 13980 PAINTED	1
2	14442	TUBE ASM 0.38X23.25 EXT CYL 6620	1
3	14443	TUBE ASM 0.38X102.25 EXT CYL 6620	1
4	14115	MANIFOLD ASM 6620 EXT CBBD-LJN-XVN	1
5	14601	CAP SCR 0.38-16X2.25 SH ZC	1
6	11882	CAP SCR 0.38-16X1.75 SH ZC	2
7	18701	CLAMP PORT TUBE ZR518	1
8	24729	HOSE CLAMP #52 3.00 - 3.75	1
9	C4660	HOSE CLAMP #24 SS	1

Cable & Hook Assembly - PN 56270

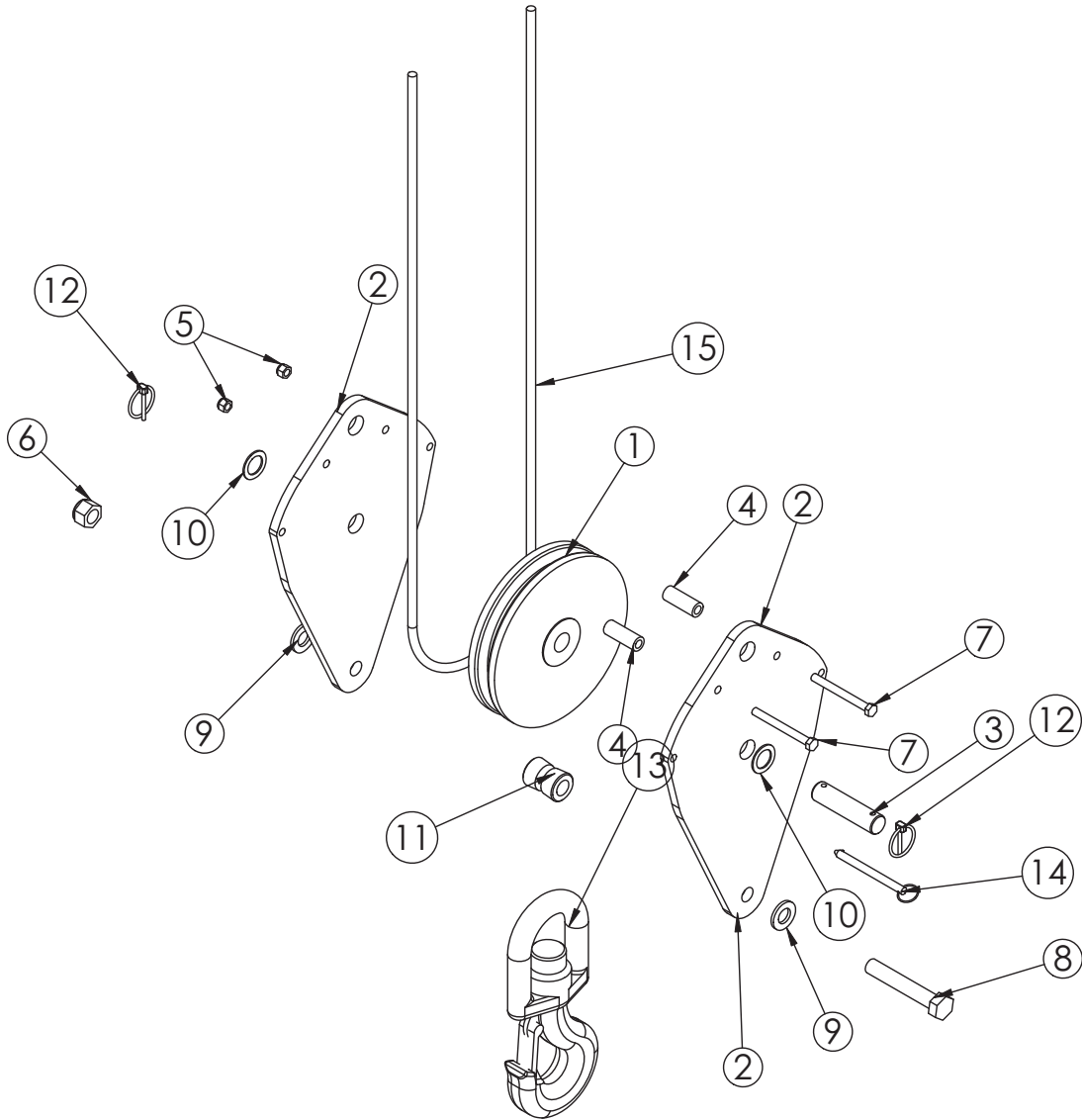

PN 56270

ITEM	PART	DESCRIPTION	QTY.
1	43858	SHEAVE 10621 9.25 DIA .44R/1.88THK	1
2	53263PC	PLATE SNATCH BLOCK 76/96/106/126	2
3	39874ZP	PIN 1.00X4.06 COTTER	1
4	44643PC	COLLAR 0.44X0.75X2.00	2
5	0347	NUT 0.38-16 HHGR5 NYLOC	2
6	C0538	NUT 0.75-10 HHGR8 NYLOC	1
7	0532	CAP SCR 0.38-16X3.75 HHGR5	2
8	5841	CAP SCR 0.75-10X4.50 HHGR8	1
9	C6219	WASHER 0.75 SAE FLAT YELLOW GR8	2
10	0867	MACHY WASHER 1.00ID 14GA	2
11	39844	BUSHING V HOOK	1
12	5753	PIN 0.19X1.56 LYNCH	2
13	26762	HOOK 7 TON SWIVEL CROSBY 1028632	1
14	13436	PIN .38X4.00 QUICK RELEASE	1
15	44812	WIRE ROPE 7/16 6X19 IWRC-DGXXIP100	1

CDT™ Radio Transmitter Assembly - PN 56647

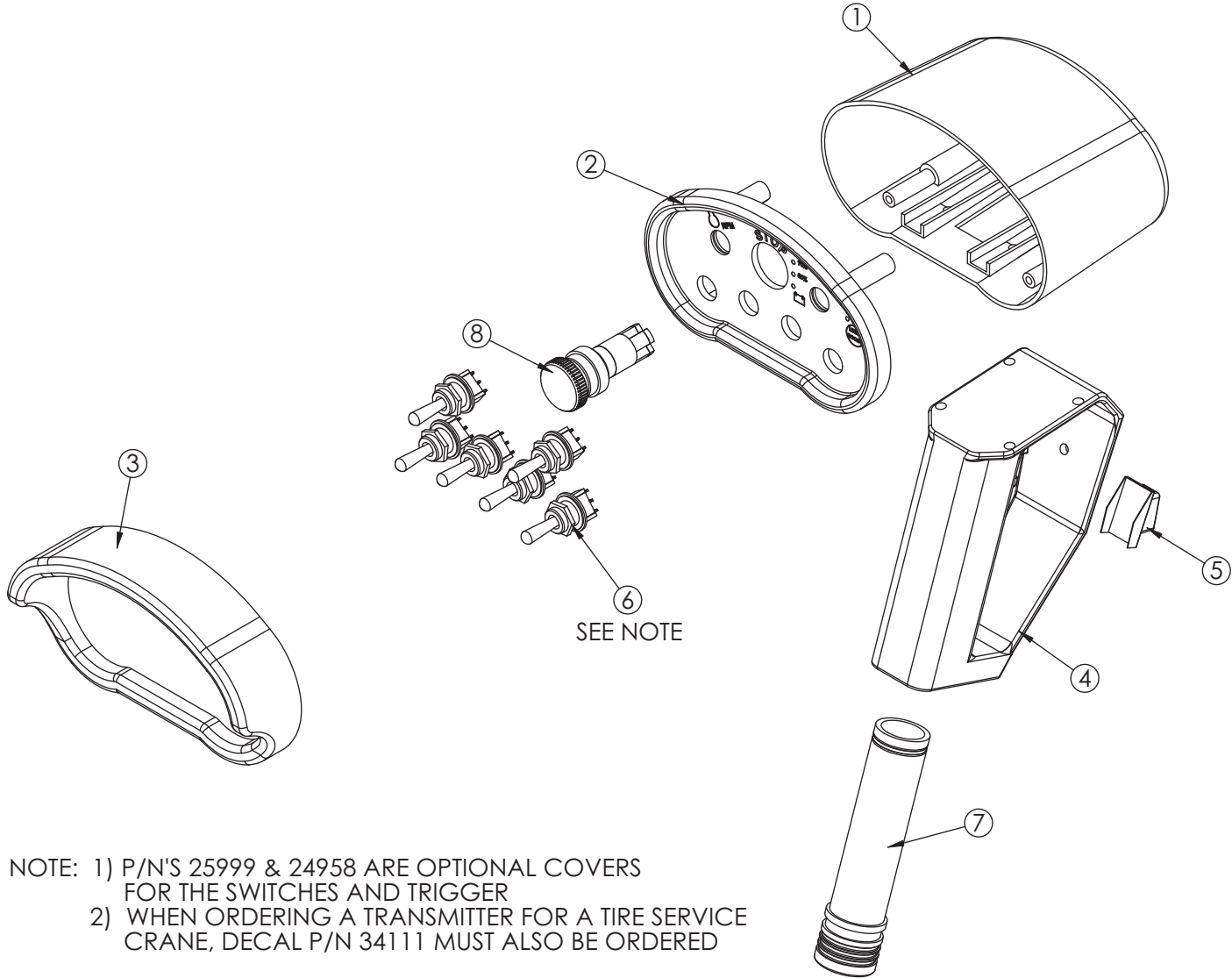

NOTE: 1) P/N'S 25999 & 24958 ARE OPTIONAL COVERS FOR THE SWITCHES AND TRIGGER
 2) WHEN ORDERING A TRANSMITTER FOR A TIRE SERVICE CRANE, DECAL P/N 34111 MUST ALSO BE ORDERED

PN 56647

ITEM	PART	DESCRIPTION	QTY.
1	20088	CONTROL HANDLE HOUSING 4 FCTN HET	1
2	56657	CONTROL HANDLE FACE PLT W/LABEL 6 FCTN CDT	1
3	24385	GUARD RADIO SWITCH 4 FCTN	1
4	35447	CONTROL HANDLE GRIP W/TRIGGER HT H2	1
5	24958	RUBBER BOOT TRIGGER GUARD HET	1
6	22600	SWITCH TOGGLE HET RADIO 63019300	6
7	35441	BATTERY TUBE AA HETRONIC RADIO	1
8	47856	SWITCH E STOP NOVA XL	1

Chapter 4 - Replacement Parts

PART#	DESCRIPTION
C6069	HYDRAULIC SWING MOTOR
25367	RELIEF VALVE
25368	SEAL KIT - RELIEF VALVE
24960	FLOW CONTROL VALVE
25369	SEAL KIT - FLOW CONTROL VALVE
25371	SOLENOID VALVE TAND G04571
25373	SEAL KIT - SOLENOID VALVE
44532	COIL - 12VDC
41910	MANIFOLD ASM - MAIN CYLINDER
41906	C-BALANCE VALVE
41907	RELIEF VALVE - CYLINDER MANIFOLD
41908	CHECK VALVE
14115	MANIFOLD ASM - EXTENSION CYLINDER
14390	O'RING - MANIFOLD ASM EXT. CYLINDER
28485	PRESSURE TRANSDUCER
6397	HYD PRESSURE GAUGE
C2027	O'RING - # 4 FACE SEAL
C2028	O'RING - # 6 FACE SEAL
C2029	O'RING - # 8 FACE SEAL
D1245	O'RING - # 4 SAE
D1246	O'RING - # 6 SAE
D1247	O'RING - # 8 SAE
25895	WORM GEAR - BEARING SWING DRIVE
25896	BEARING & SEAL KIT - BEARING SWING DRIVE
35646	SEAL KIT (MAIN LIFT CYLINDER)
20450	SEAL KIT (EXTENSION CYLINDER)
44066	TUBE ASM - MAIN CYLINDER
14442	TUBE ASM - EXTENSION CYLINDER
14443	TUBE ASM - EXTENSION CYLINDER
4380	BUSHING 2.00"x 1.50"
4381	BUSHING 2.00"x 2.00"
#0068	BUSHING
44533	BUSHING 2.00" x 0.75"
9991	WEAR PAD 2.50" ROUND
13395	WEAR PAD 3.00"X3.00"X1.00"
13396	WEAR PAD 2.50"X2.50"X1.00"
8377	PIN CAP .56 X 3.50 X .25
7403	PIN CAP .44 X 2.50 X .25
D0790	WASHER 0.50 FLAT GR8
10172	CAP SCR. 0.50-13 X 1.00"
43858	SHEAVE
43857	WIRE ROPE
12824	HITCH PIN 1.00" X 4.50"
13436	QUICK RELEASE PIN .38 X 4.00"
11938	LIMIT SWITCH (FLIP SHEAVE VERSION)
35105	LIMIT SWITCH (NON-FLIP SHEAVE VERSION)
19166	CORD REEL
35441	BATTERY TUBE (AA) HOLDER (HETRONIC RADIO)
22600	TOGGLE SWITCH (HETRONIC RADIO)
35447	HANDLE / TRIGGER ASM (HETRONIC RADIO)
19994PC	ANTI - 2 BLOCK WEIGHT
27710	ANTI - 2 BLOCK SPRING
5753	LYNCH PIN
26762	HOOK 7-TON
38676	7-TON HOOK SAFETY LATCH ASM.



Limited Warranty Statement

Stellar Industries, Inc. (Stellar) warrants products designed and manufactured by Stellar to be free from defects in material and workmanship under proper use and maintenance. Products must be installed and operated in accordance with Stellar's written instructions and capacities. This warranty shall cover the following:

Stellar Cranes, Stellar Hooklift Hoists, Stellar Cable Hoists, Stellar Container Carriers, Stellar Service Trucks, and Stellar X-Tra-Lift Systems:

Twelve (12) month warranty on parts from the date recorded by Stellar as the in-service date, not to extend beyond twenty-four (24) months from date of manufacture.

Twelve (12) month repair labor from the date recorded by Stellar as the in-service date, not to extend beyond twenty-four (24) month from date of manufacture, and

Thirty-six (36) month warranty on all Stellar Manufactured structural parts from the date recorded by Stellar as the in-service date, not to extend beyond forty-eight (48) months from date of manufacture.

Stellar Tarper Systems:

Twelve (12) month warranty on parts from the date recorded by Stellar as the in-service date, not to extend beyond twenty-four (24) months from date of manufacture and

Three (3) month repair labor from the date recorded by Stellar as the in-service date, not to extend beyond fifteen (15) month from date of manufacture.

The in-service date will be derived from the completed warranty registration card. In the event a warranty registration card is not received by Stellar, the factory ship date will be used.

Stellar's obligation under this warranty is limited to, and the sole remedy for any such defect shall be, the repair and/or replacement (at Stellar's option) of the unaltered part and/or component in question. Stellar after-sales service personnel must be notified by telephone, fax, or letter of any warranty-applicable damage within fourteen (14) days of its occurrence. If at all possible, Stellar will ship the replacement part within 24-hours of notification by the most economical, yet expedient, means possible. Expedited freight delivery will be at the expense of the owner.

Warranty claims must be submitted and shall be processed in accordance with Stellar's established warranty claim procedure. Stellar after-sales service personnel must be contacted prior to any warranty claim. A return materials authorization (RMA) account number must be issued to the claiming party prior to the return of any warranty parts. Parts returned without prior authorization will not be recognized for warranty consideration. All damaged parts must be returned to Stellar freight prepaid; freight collect returns will be refused. Freight reimbursement of returned parts will be considered as part of the warranty claim.

Warranty service will be performed by any Stellar new equipment distributor, or by any Stellar-recognized service center authorized to service the type of product involved, or by the Stellar factory in the event of a direct sale. At the time of requesting warranty service, the owner must present evidence of date of delivery of the product. The owner shall be obligated to pay for any overtime labor requested of the servicing company by the owner, any field service call charges, and any towing and/or transportation charges associated with moving the equipment to the designated repair/service provider.

All obligations of Stellar and its authorized dealers and service providers shall be voided if someone other than an authorized Stellar dealer provides other than routine maintenance service without prior written approval from Stellar. In the case repair work is performed on a Stellar-manufactured product, original Stellar parts must be used to keep the warranty in force. The warranty may also be voided if the product is modified or altered in any way not approved, in writing, by Stellar.

The owner/operator is responsible for furnishing proof of the date of original purchase of the Stellar product in question. Warranty registration is the ultimate responsibility of the owner and may be accomplished by the completion and return of the Stellar product registration card provided with the product. If the owner is not sure of registration, he is encouraged to contact Stellar at the address below to confirm registration of the product in question. This warranty covers only defective material and workmanship. It does not cover depreciation or damage caused by normal wear and tear, accident, mishap, untrained operators, or improper or unintended use. The owner has the obligation of performing routine care and maintenance duties as stated in Stellar's written instructions, recommendations, and specifications. Any damage resulting from owner/operator failure to perform such duties shall void the coverage of this warranty. The owner will pay the cost of labor and supplies associated with routine maintenance.

The only remedies the owner has in connection with the breach or performance of any warranty on the Stellar product specified are those set above. In no event will Stellar, the Stellar distributor/dealer, or any company affiliated with Stellar be liable for business interruptions, costs of delay, or for any special, indirect, incidental, or consequential costs or damages. Such costs may include, but are not limited to, loss of time, loss of revenue, loss of use, wages, salaries, commissions, lodging, meals, towing, hydraulic fluid, or any other incidental cost.

All products purchased by Stellar from outside vendors shall be covered by the warranty offered by that respective manufacturer only. Stellar does not participate in, or obligate itself to, any such warranty.

Stellar reserves the right to make changes in design or improvement upon its products without imposing upon itself the same upon its products theretofore manufactured.

This warranty will apply to all Stellar Cranes, Stellar Hooklift Hoists, Stellar Cable Hoists, Stellar Container Carriers, Stellar Service Trucks, Stellar X-Tra-Lift Systems, and Stellar Tarper Systems shipped from Stellar's factory after January 1st, 2010. The warranty is for the use of the original owner only and is not transferable without prior written permission from Stellar.

THIS WARRANTY IS EXPRESSLY IN LIEU OF ANY OTHER WARRANTIES, EXPRESS OR IMPLIED, INCLUDING ANY WARRANTY OF MERCHANTABILITY OR FITNESS FOR A PARTICULAR PURPOSE. REMEDIES UNDER THIS WARRANTY ARE LIMITED TO THE PROVISION OF MATERIAL AND SERVICES, AS SPECIFIED HEREIN. STELLAR INDUSTRIES, INC. IS NOT RESPONSIBLE FOR INCIDENTAL OR CONSEQUENTIAL DAMAGES.

Revision Date: February 2010

Document Number: 37040