

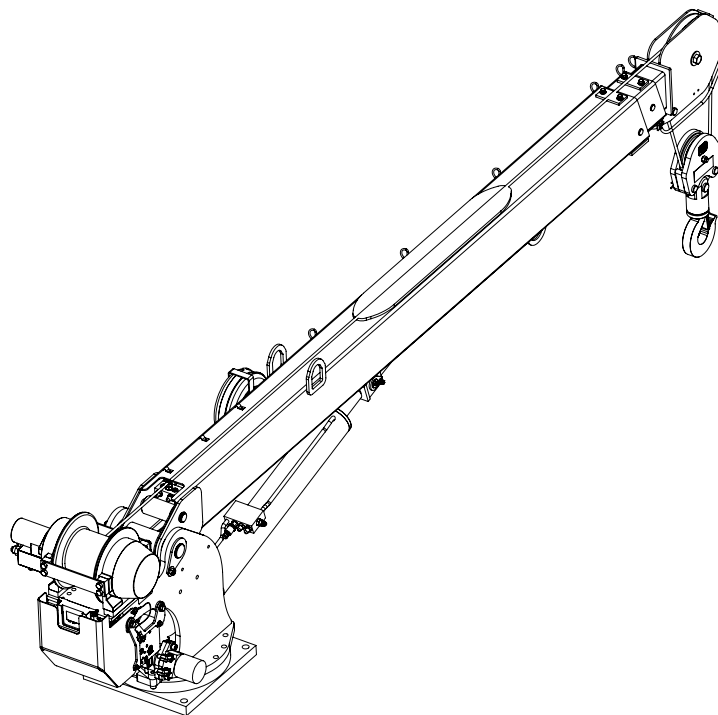

HC-5 NEXSTAR III OWNERS MANUAL



Serial No. _____

Mailing Address:
P.O. Box 580697
Tulsa, OK 74158-0697
Physical Address: 4707
N. Mingo Rd. Tulsa, OK
74117-5904

Phone 1-800-777-2760
Fax (918) 269-6688
<http://www.autocrane.com>



Auto Crane Registration

From: _____ Date: _____

End User Information:

Company: _____ Phone: _____

Address: _____

City: _____ State: _____ Zip: _____

Contact: _____ E-mail: _____

Distributor Information:

Company: _____ Phone: _____

Address: _____

City: _____ State: _____ Zip: _____

Contact: _____ E-mail: _____

Product Information:

Model No: _____ Serial No: _____ Date Delivered: _____

VIN #: _____

ONE REGISTRATION FORM PER UNIT (CRANE, BODY, OR COMPRESSOR)

Please submit form within 15 days after installation

Online: www.autocrane.com | Resources | Warranties

Fax: 918-234-2177

Mail: Product Registration, Auto Crane Company, PO Box 580697, Tulsa, OK 74158-0697

WARNINGS

WARNING! Federal law (49 cfr part 571) requires that the Final Stage Manufacturer of a vehicle certify that the vehicle complies with all applicable federal regulations. Any modifications performed on the vehicle prior to the final state are also considered intermediate stage manufacturing and must be certified as to compliance. The installer of this crane and body is considered one of the manufacturers of the vehicle. As such a manufacturer, the installer is responsible for compliance with all applicable federal and state regulations, and is required to certify that the vehicle is in compliance.

WARNING! It is the further responsibility of the installer to comply with the OSHA Truck Crane Stability Requirements as specified by 29 CFR part 1910.180 (C) (1).

WARNING! NEVER OPERATE THE CRANE NEAR ELECTRICAL POWER LINES!
Death or serious injury will result from boom, line, or load contacting electric lines. Do not use crane within 10 feet (3.05m) of electric power lines carrying up to 50,000 volts. One-foot additional clearance is required for every additional 30,000 volts or less. SEE DANGER DECAL (P/N 040529) in this Owner's Manual.

WARNING! NEVER.....

- ◆ EXCEED load chart capacities (centerline of rotation to hoist hook).
- ◆ Un-reel last 5 wraps of cable from drum!
- ◆ Wrap cable around load!
- ◆ Attempt to lift or drag a load from the side! The boom can fail far below its rated capacity.
- ◆ Weld, modify, or use unauthorized components on any Auto Crane unit! This will void any warranty or liability. Also failure of the crane may result.
- ◆ Place a chain link on the tip of the hook and try to lift a load!
- ◆ Use a sling bar or anything larger than the hook throat that could prevent the hook latch from closing, thus negating the safety feature!
- ◆ Hold on any pendant Select Switch that will cause unsafe operating conditions!

WARNING! In using a hook with latch, ALWAYS make sure that the hook throat is closed before lifting a load! Proper attention and common sense applied to the use of the hoist hook and various slings will prevent possible damage to material being hoisted and may prevent injury to personnel.

WARNING! Failure to correctly plumb and wire crane can cause inadvertent operation and damage to crane and/or personnel!

WARNING! Auto Crane Company remote controlled cranes are not designed or intended for use for any applications involving the lifting or moving of personnel.

WARNING! ALWAYS operate the crane in compliance with the load capacity chart. DO NOT USE the overload shutdown device to determine maximum rated loads, if the crane is equipped with this type of device.

READ THIS PAGE

TABLE OF CONTENTS

INTRODUCTION	1
GENERAL SPECIFICATIONS	3
SAFETY TIPS AND PRECAUTIONS	4
QUALIFICATIONS FOR OPERATORS	7
OPERATION OF UNIT / OUTRIGGERS	10
CRANE OPERATION	11
TRANSMITTER SYNCHRONIZATION INSTRUCTIONS	15
INSPECTION REQUIREMENTS	16
TESTING REQUIREMENTS	18
GENERAL REPAIRS AND MAINTENANCE	19
MAINTENANCE OF BATTERIES	21
LUBRICATION AND MAINTENANCE SCHEDULE	23
BEARING REPLACEMENT	25
SAFETY DECAL SECTION	26
GENERAL DIMENSIONS	32
MOUNTING AND INSTALLATION	34
GENERAL ASSEMBLY	36
PEDESTAL ASSEMBLY	38
BOOM ASSEMBLY	44
ROTATION GEARBOX	46
HOIST ASSEMBLY	48
TRAVELING BLOCK ASSEMBLY	51
MAIN WIRING HARNESS	52
HYDRAULIC SECTION	54
COUNTERBALANCE VALVE ADJUSTMENT	56
VALVE OVERRIDE OPERATION	57
TROUBLESHOOTING CHARTS	58
CARTRIDGE MAINTENANCE	63
LOAD CHART	64
PREVENTATIVE MAINTENANCE	65
WARRANTY	LAST 2 PAGES

HC-5 INTRODUCTION

Auto Crane products are designed to provide many years of safe, trouble-free, dependable service when properly used and maintained.

To assist you in obtaining the best service from your crane and to avoid untimely crane and/or vehicle failure, this manual provides the following operating and service instructions. It is specifically recommended that all operating and service personnel consider this manual as mandatory material for reading and study before operating or servicing Auto Crane products. It is highly recommended that crane owners, equipment managers, and supervisors also read this manual.

Auto Crane has incorporated several safety features in the HC-5 crane for your protection.

For your convenience the overall dimensions of the HC-5 crane are included on the General Dimension Drawing. Rotation and turning radius are also listed on that drawing.

Remember, the crane adds weight to the vehicle. Adding weight may change the driving and riding characteristics of the vehicle unless the appropriate overload spring(s) are installed on the truck. The payload of the vehicle is reduced by the weight of the crane. The operator should exercise care when loading the vehicle. Distributing the payload on the vehicle evenly will greatly improve the driving and riding characteristics of the vehicle.

Auto Crane Company issues a limited warranty certificate with each unit sold. See last page for warranty.

The HC-5 cranes are attached to your 12-volt truck electrical system through the relay provided. The HC-5 is another highly efficient Auto Crane product. The use of a maintenance-free battery is not recommended on any Auto Crane product. The recommended alternator and battery that will give the longest life with the most useful duty cycle is a 60-amp

alternator with a 500 cold cranking amp battery. These specifications should be considered minimum.

It has always been Auto Crane Company policy to handle all warranty claims we receive as promptly as possible. If a warranty claim involves discrepant material or workmanship, Auto Crane will take immediate corrective action. It is understandable that Auto Crane Company cannot assume responsibility of liability when it is obvious that our products have been abused, misused, overloaded or otherwise damaged by inexperienced persons trying to operate the equipment without reading the manual.

Auto Crane will not assume responsibility or liability for any modifications or changes made to unit, or installation of component parts without authorization.

Auto Crane maintains a strong distributor network and a knowledgeable Customer Service Department. In most cases, an equipment problem is solved via phone conversation with our customer service department. The customer service department also has the ability to bring a local distributor, a regional sales manager, or a factory serviceman into the solution of an equipment problem.

If, through no fault of Auto Crane Company, it is necessary to send an experienced factory serviceman on a field service call the rates stated in the Auto Crane Distributor's Flat Rate Manual will apply.

Auto Crane Company's extensive Research and Development Program allow our customers to use the best equipment on the market. Our Engineering Staff and our knowledgeable sales people are always available to our customers in solving crane and winch-type application problems. When in doubt, call the Auto Crane factory.

Note: This manual should remain with the crane at all times.

HC-5 INTRODUCTION

DISTRIBUTOR ASSISTANCE:

Should you require any assistance not given in this manual, we recommend that you consult your nearest Auto Crane Distributor. Our distributors sell authorized parts and have service departments that can solve almost any needed repair. This manual does not cover all maintenance, operating, or repair instructions pertinent to all possible situations.

If you require additional information, please contact the Auto Crane Company at the following telephone number: 1-800-777-2760. The information contained in the manual is in effect at the time of this printing. Auto Crane Company reserves the right to update this material without notice or obligation.

HC-5

GENERAL SPECIFICATIONS

DIMENSIONS

Width: 21.25 in (0.54 m)
Height: 35.25 in (0.90 m)
Length: 12 ft 10 in (3.91 m)
 [Boom(s) stored]
Weight: 1,390 lbs (630 kg)

CAPACITY

25,000 ft-lbs (3.81ton-m)
 [ft-lbs = horizontal distance from centerline of rotation to free hanging weight (feet) x amount of weight (pounds)]

LIFTING CAPACITIES

FT	LBS	FT	LBS
5	5,000	14	1,752
8	3,240	16.5	1,439
10.5	2,424	18	1,300
12	2,032	20.5	1,115

REACH

Second boom will reach from 10 feet 4 inches to 16 feet 4 inches.
 Third boom will reach from 16 feet 4 inches to 20 feet 4 inches.

CABLE

80 ft (24.4 m) of 5/16 in (7.9 mm) diameter aircraft quality cable. This cable has a single line breaking strength of 9,800 lbs (4,445.2 kg).

CHASSIS REQUIREMENTS

14,500 lbs (6,577 kg) GVWR minimum
 300,000 in-lbs RBM

HYDRAULIC REQUIREMENTS

8 gpm flow @ 2,750 psi

ELECTRICAL SYSTEM REQUIREMENTS

Voltage: 12 VDC
Alternator: 60 amps (minimum)
Battery: 100 minute reserve capacity (minimum) Maintenance type

ROTATION

370° Rotation with electric stop.

-IMPORTANT- SAFETY TIPS AND PRECAUTIONS

1. No unqualified or unauthorized person shall be allowed to operate the crane.
2. **WARNING:** Never weld, modify, or use unauthorized components / parts on any Auto Crane unit. This will void any warranty or liability. Also, failure of the crane may result.
3. Make certain the vehicle meets minimum chassis requirements. (These requirements do not guarantee unit stability.)
4. Make certain the crane is installed per factory specifications. Contact your local distributor or the Auto Crane factory if any questions arise.
5. Visual inspections and tests should be conducted at the beginning of each shift each day to insure that the crane and all its operating systems are in good condition and working order before it is used.
6. Inspect hydraulic hoses frequently for signs of deterioration, and replace them as required.
7. If a hydraulic break occurs, leave the area of the break and do not attempt to stop the break by hand as the hydraulic oil may be hot and under high pressure which can cause serious injury. Shut the system down as soon as possible.
8. Check the hook at least every thirty days for distortions or cracks and replace it as required.
9. Oil gears as required.
10. Stop all operations when cleaning, adjusting or lubricating the machine.
11. Keep dirt and grit out of moving parts by keeping crane clean. Make sure machine is free of excess oil, grease, mud and rubbish, thus reducing accidents and fire hazards.
12. When a new cable is installed, operate first with a light load to let the cable adjust itself.
13. Locate the vehicle at the work site for the best stability possible.
14. Keep the vehicle in a level position while loading or unloading.
15. Observe operating area for obstructions and/or power lines that might be a hazard.
16. **WARNING: NEVER OPERATE THE CRANE NEAR ELECTRICAL POWER LINES.** Auto Crane Company recommends that the crane never be any closer to a power line (including telephone lines) than 10 feet at any point.
17. Allow the vehicle engine to warm up before operating crane.
18. Know the weight of your rigging and load to avoid overloading the crane.
19. Deduct the weight of the load handling equipment from the load rating to determine how much weight can be lifted.
20. All load ratings are based on crane capacity, NOT the vehicle stability. Remember in lifting a heavy load, the weight can create enough tipping moment to overturn the vehicle
21. Always comply with load chart capacities, (centerline of rotation to hook).
22. Secure all loads before lifting.
23. Always set the emergency brake before beginning operation.
24. Keep objects and personnel clear of crane path during operation.
25. Operate control levers slowly and smoothly in order to meter oil flow for safe operation. (Not applicable to electric-hydraulic cranes.)
26. Always extend the outriggers from vehicle to the ground before crane operation. Insure that they are firmly positioned on solid footings. Stand clear of outriggers while they are being extended.
27. If any outrigger, when extended, rests on a curb or other object that prevents it from extending to its maximum distance, shorten bearing or fulcrum point and reduce the maximum load accordingly.
28. When an outrigger will not reach the ground due to holes or grades, it shall be blocked up to provide level and firm support for the truck.
29. When working in soft earth, use wide pads under outrigger feet to prevent sinking.
30. Always store outriggers before transportation.

WARNING!

Auto Crane Company cranes are not designed or intended for use in lifting or moving persons. Any such use shall be considered to be improper and the seller shall not be responsible for any claims arising there from. This sale is made with the express understanding that there is no warranty that the goods shall be fit for the purpose of lifting or moving persons or other improper use and there is no implied warranty or responsibility for such purposes.

-IMPORTANT- SAFETY TIPS AND PRECAUTIONS

31. Always store the crane in its stowed position for transportation.
 32. Remember the overall height of the entire unit for garage door clearance or when moving under objects with low overhead clearance
 33. Disengage power takeoff (PTO) before moving the vehicle.
(Not applicable to electric-hydraulic cranes.)
 34. Always walk around the vehicle before moving.
 35. Never drive with a load suspended from crane.
 36. Do not take your eyes off a moving load. Look in the direction you are moving.
 37. Never swing a load over people.
 38. Do not stop the load sharply in midair so that it swings like a pendulum. Meter the control levers to avoid this situation. (Not applicable to electric-hydraulic cranes.)
 39. Crane boom length should be kept as short as possible for maximum lifting capacity and greater safety. Longer booms require additional care in accelerating and decelerating the swing motion, and thus slow down the working cycle and reduce productivity.
 40. Keep the load directly and vertically under the boom point at all times. Crane booms are designed to handle vertical loads, not side lifts.
41. Do not push down on anything with boom extensions; similarly do not lift anything with boom extensions.
 42. Do not lift personnel with any wire rope attachment or hook. There is no implied warranty or responsibility for such purposes.
 43. **WARNING:** In using a safety hook, ALWAYS close the hook throat before lifting a load. Proper attention and common sense applied to the use of the hook and various slings will prevent possible damage to material being hoisted and may prevent injury to personnel.
 44. **WARNING:** Never place a chain link on the tip of the hook and try to lift a load with the hoist.
 45. **WARNING:** Never use a sling bar or anything larger than the hook throat which could prevent the safety latch from closing, thus negating the safety feature.
 46. Do not wrap the wire rope around sharp objects when using winch.
 47. **WARNING:** Never unreel last 5 wraps of cable from drum.

-IMPORTANT- SAFETY TIPS AND PRECAUTIONS

1. Make certain the vehicle meets minimum chassis requirements. (These requirements do not guarantee unit stability)
2. Make certain the crane is installed per factory specifications. Contact your local Distributor or the Auto Crane factory if any questions arise.
3. Keep the vehicle in as level a position as possible while loading or unloading.
4. **ALWAYS** set the vehicle emergency brake before beginning crane operations.
5. **ALWAYS** use outriggers from vehicle to the ground during crane operation. Make sure they are firmly positioned on solid footings.
6. All load ratings are based on crane capacity, **NOT** truck/crane stability.
7. Keep objects and personnel clear of crane path during operation.
8. Keep hoist cable pulled tight at all times.
9. **REMEMBER**, in lifting a heavy load, the weight can create enough tipping momentum to overturn the vehicle.
10. **ALWAYS** keep load as close to ground as possible.
11. Hydraulic hoses need to be inspected frequently for signs of deterioration, and be replaced as required.
12. The hoist hook is an important item that an operator should consider and use properly. It should be checked on a daily basis for distortion or cracks.
13. **ALWAYS** store outriggers before road travel.
14. In applications, where the rotation of the load is hazardous, a tag or restraint line should be used, (ref. OSHA 1910.180(h)(3)(xvi)). To reduce the potential for the load to rotate or rope twist, operate at minimal boom angles and extension.
15. **WARNING! NEVER OPERATE THE CRANE NEAR ELECTRICAL POWER LINES!** Death or serious injury will result from boom, line, or load contacting electric lines. Do not use crane within 10 feet (3.05m) of electric power lines carrying up to 50,000 volts. One foot additional clearance is required for every additional 30,000 volts or less.
16. **WARNING! NEVER EXCEED** load chart capacities (centerline of rotation to hoist hook).
17. **WARNING! NEVER** un-reel last 5 wraps of cable from drum!
18. **WARNING! NEVER** wrap cable around load!
19. **WARNING! NEVER** attempt to lift or drag a load from the side! The boom can fail far below its rated capacity.
20. **WARNING! NEVER** weld, modify, or use unauthorized components on any Auto Crane unit! This will void any warranty or liability. Also failure of the crane may result.
21. **WARNING! NEVER** place a chain link on the tip of the hook and try to lift a load!
22. **WARNING! NEVER** use a sling bar or anything larger than the hook throat that could prevent the hook latch from closing, thus negating the safety feature!
23. **WARNING!** In using a hook with latch, **ALWAYS** insure that the hook throat is closed before lifting a load! Proper attention and common sense applied to the use of the hoist hook and various slings will prevent possible damage to material being hoisted and may prevent injury to personnel.
WARNING! NEVER hold any Control Select Switch on that will cause unsafe operating conditions!

WARNING!

Auto Crane Company remote controlled, stiff boom cranes are not designed or intended for use on any applications involving the lifting or moving of personnel.

QUALIFICATIONS FOR AND CONDUCT OF OPERATORS AND OPERATING PRACTICES

REFERENCE ASME B30.5a AND OSHA 1910.180 FOR COMPLETE QUALIFICATION REQUIREMENTS

OPERATORS

1. Crane operation shall be limited to personnel with the following minimum qualifications:
 - A. Designated persons.
 - B. Trainees under the direct supervision of a designated person.
 - C. Maintenance and test personnel (when it is necessary in the performance of their duties).
 - D. Inspectors (crane).
2. No one other than the personnel specified above shall enter the operating area of a crane with the exception of persons such as oilers, supervisors, and those specified persons authorized by supervisors whose duties require them to do so and then only in the performance of their duties and with the knowledge of the operator or other persons.

QUALIFICATIONS FOR OPERATORS

1. Operators shall be required by the employer to pass a practical operating examination. Qualifications shall be limited to the specific type of equipment for which examined.
2. Operators and operator trainees shall meet the following physical qualifications:
 - A. Vision of at least 20/30 Snellen in one eye and 20/50 in the other, with or without corrective lenses.
 - B. Ability to distinguish colors, regardless of position, if color differentiation is required for operation.
 - C. Adequate hearing with or without hearing aid for the specific operation.
3. Evidence of physical defects or emotional instability, which render a hazard to operator or others, which in the opinion of the examiner could interfere with the operator's performance, may be sufficient cause for disqualification. In such cases, specialized clinical or medical judgment and tests may be required.
4. Evidence that operator is subject to seizures or loss of physical control shall be sufficient reason for disqualification. Specialized medical

tests may be required to determine these conditions.

5. Operators and operator trainees should have normal depth perception, coordination, and no tendencies to dizziness or similar undesirable characteristics.
6. In addition to the above listed requirements, the operator shall:
 - A. Demonstrate the ability to comprehend and interpret all labels, operator's manuals, safety codes, and other information pertinent to correct crane operations.
 - B. Posses the knowledge of emergency procedures and implement it.
 - C. Demonstrate to the employer the ability to operate the specific type of equipment.
 - D. Be familiar with the applicable safety regulations.
 - E. Understand the operating procedures as outlined by the manufacturer.
 - F. Be thoroughly familiar with the crane and its control functions.
 - G. Understand the operating procedures as outlined by the manufacturer.

CONDUCT OF OPERATORS

1. The operator shall not engage in any practice, which will divert his attention while actually operating the crane.
2. Each operator shall be responsible for those operations under the operator's direct control. Whenever there is any doubt as to safety, the operator shall consult with the supervisor before handling the loads.
3. The operator should not leave a suspended load unattended unless specific precautions have been instituted and are in place.
4. If there is a warning sign on the switch or engine starting controls, the operator shall not close the switch or start the engine until the warning sign has been removed by the appointed person.
5. Before closing the switch or starting the engine, the operator shall see that all controls are in the "OFF"

QUALIFICATIONS FOR AND CONDUCT OF OPERATORS AND OPERATING PRACTICES

or neutral position and all personnel are in the clear.

6. If power fails during operation, the operator shall:
 - A. Move power controls to the "OFF" or neutral position.
 - B. Land the suspended load and boom, if practical.
 7. The operator shall be familiar with the equipment and its proper care. If adjustments or repairs are necessary, the operator shall report the same promptly to the appointed person, and shall also notify the next operator.
 8. The operator at the start of each shift shall test all controls. If any controls do not operate properly, they shall be adjusted or repaired before operations are begun.
 9. Stabilizers shall be visible to the operator while extending or setting unless a signal person assists operator.
- C. Means are provided to hold the vehicle stationary while operating the crane.
 - D. Before starting to lift, the hook shall be positioned over the load in such a manner as to minimize swinging.
 - E. During lifting care shall be taken that:
 1. There is no sudden acceleration or deceleration of the moving load.
 2. Load, boom or other parts of the crane do not contact any obstruction.
 - F. Cranes shall not be used for dragging loads sideways.
 - G. This standard recognizes that telescopic boom cranes are designed and intended for handling materials. They do not meet personnel lift or elevator requirements. Therefore, no lifting, lowering, swinging or traveling shall be done while a person is on the hook or load. Hook attached suspended work platforms (baskets) shall not be used with cranes covered by this standard. Crane manufacturer must approve work platforms attached to the boom.
 - H. The operator should avoid carrying loads over people.
 - I. When the crane is so equipped, the stabilizers shall be fully extended and set. Blocking under stabilizers shall meet the requirements as follows:
 1. Strong enough to prevent crushing.
 2. Of such thickness, width and length as to completely support the stabilizer pad.
 - J. Firm footing under all tires, or individual stabilizer pads should be level. Where such a footing is not otherwise supplied, timbers, cribbing, or other structural members to distribute the load so as to not exceed allowable bearing capacity or the underlying material should provide it.
 - K. In transit, the boom shall be carried in stowed position.
 - L. When rotating the crane, sudden starts and stops shall be avoided. Rotational speed shall be such that the load does not swing out beyond the radius at which it can be controlled.
 - M. The crane shall not be transported with a load on the hook unless recommended by the manufacturer.

OPERATING PRACTICES/HANDLING THE LOAD

1. Size of load.
 - A. No crane shall be loaded beyond the rated load except for test purposes
 - B. The load to be lifted is to be within the rated load of the crane and its existing configuration.
 - C. When loads that are not accurately known are to be lifted, the person responsible for the job shall ascertain that the weight of the load does not exceed the crane rated load at the radius at which the load is to be lifted.
2. Attaching the load.
 - A. The load shall be attached to the hook by means of slings or other devices of sufficient capacity.
 - B. Hoist rope shall not be wrapped around the load.
3. Moving the load.

The operator shall determine that:

 - A. The crane is level and, where necessary, the vehicle/carrier is blocked properly.
 - B. The load is well secured and balanced in the sling or lifting device before it is lifted more than a few inches.

QUALIFICATIONS FOR AND CONDUCT OF OPERATORS AND OPERATING PRACTICES

- N. No person should be permitted to stand or pass under a suspended load.
4. Stowing procedure.
Follow the manufacturer's procedure and sequence when stowing and un-stowing the crane.

MISCELLANEOUS

OPERATING NEAR ELECTRICAL POWER LINES

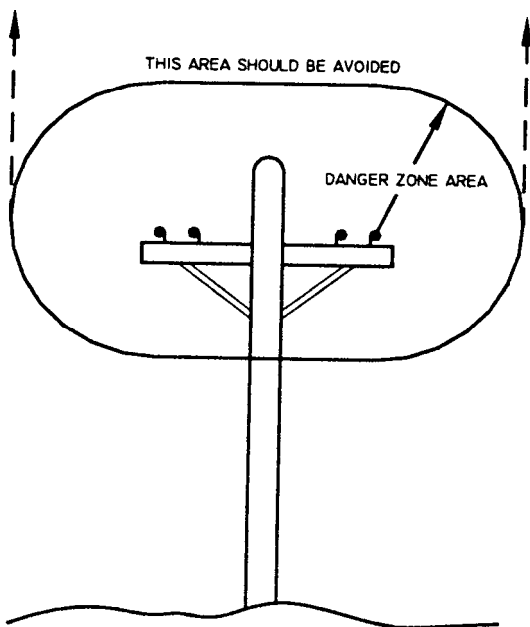

1. Cranes shall be operated so that no part of the crane or load enters into the danger zone shown above.

EXCEPTIONS

- A. The danger zone may be entered after confirmation by an appointed person that the electrical distribution and transmission lines have been de-energized and visibly grounded at the point of work; or
- B. The danger zone may be entered if insulating barriers (not a part of nor an attachment to the crane) have been erected to prevent physical contact with the lines.
2. For lines rated 50 kV or below, minimum clearance between the lines and any part of the crane or load (including handling appendages) shall be 10-ft. (3m). For higher voltages, see Table 1.

3. Caution shall be exercised when working near overhead lines, because they can move horizontally or vertically due to wind, moving the danger zone to new positions.
4. In transit with no load and boom lowered the clearance shall be specified in Table 1.
5. A qualified signalperson shall be assigned to observe the clearance and give warning before approaching the above limits.
- A. Any overhead wire shall be considered to be an energized line unless and until the person owning such line or the electrical utility authorities verify that it is not an energized line.
- B. Exceptions to this procedure are allowed, if approved by the administrative or regulatory authority provided the alternate procedure insures equivalent protection and is set forth in writing.
- C. Durable signs shall be installed at the operator's station and on the outside of the crane, warning that electrocution or serious bodily injury may occur unless a minimum clearance of 10 ft. (3.0m) between the crane or the load being handled and energized power lines. Greater clearances are required because of higher voltage as stated above. These signs shall be revised but not removed when local jurisdiction requires greater clearances.

TABLE 1				
			<u>minimum required clearance</u>	
<u>normal voltage, kV</u>			<u>ft</u>	<u>(m)</u>
<u>(phase to phase)</u>				
<u>when operating near high voltage power lines</u>				
over		to 50	10	(3.50)
over	50	to 200	15	(4.6)
over	200	to 350	20	(6.1)
over	350	to 500	25	(7.62)
over	500	to 750	35	(10.67)
over	750	to 1000	45	(13.72)
<u>while in transit with no load and boom lowered</u>				
over		to 0.75	4	(1.22)
over	0.75	to 50	6	(1.83)
over	50	to 345	10	(3.83)
over	345	to 750	16	(4.87)
over	750	to 1000	20	(6.1)

-IMPORTANT- BEFORE OPERATING CRANE

1. Make sure this manual has been thoroughly read by all crane operating personnel and supervisors.
2. A routine inspection of the crane should be mandatory before each operating day. Any defects should be corrected immediately.
3. At a job site the vehicle should be positioned so that the crane can adequately reach the load within the rated capacity (centerline of rotation to hoist hook).
4. Keep the vehicle as level as possible during operation. **CANNOT EXCEED 10° SLOPE.**
5. For electric cranes, **engage emergency brake** and leave ignition on with transmission in neutral (or in park for automatic transmissions). Activate any crane power switches. For Auto Crane units requiring battery and hydraulic operation, **engage emergency brake**, place gear selector in neutral, press clutch, activate PTO, release clutch and after hydraulic fluid is warm, set throttle control to proper engine speed.
6. Always use outriggers from the truck to the ground. Be sure these are firm and adequately positioned. When rotating, **keep load as low to the ground as possible.**
7. Remove the transmitter from cab or storage area. Power transmitter on. Detach hook from dead man. Crane is now ready for operation.
8. Always boom up before rotating so the boom will clear the required boom support.
9. When extending the boom, always maintain clearance between the boom crown and the traveling block or hoist hook.
10. Always observe safe and practical operation to avoid possible accidents. Refer to Safety Tips and Precautions.
11. After completing lifting operations, return the boom to stowed position on the boom support. Avoid unneeded pressure on the boom support.
12. Store transmitter in proper location (in cab or storage area).
13. Return outriggers to stowed position. Make sure they are pinned in place or jacklegs are returned to compartment.
14. Check work area for any tools or equipment not stored.
15. Release throttle control, depress clutch and disengage PTO. Deactivate any crane power switches.
16. Report any unusual occurrence during crane operation that may indicate required maintenance or repair.
17. **NEVER** use two cranes to support a load too large for either crane.

OPERATION OF OUTRIGGERS

HYDRAULIC OUTRIGGERS

1. Shift crane/outrigger control valve to "outrigger" position.
2. Operate the outrigger control valves to position the outriggers.
3. After outriggers are positioned, return crane/outrigger selector to "crane" position.
4. Crane is now ready to operate.

MANUAL OUTRIGGERS

1. Pull lock pins to release jackleg or drop down outrigger and move to outermost lock position.
2. Make sure lock pins are reinstalled properly.
3. Lower outrigger pad to firm ground and adjust foot to take out slack.
4. Crane is now ready to operate.

NEXSTAR III CRANE OPERATION

TRANSMITTER LAYOUT

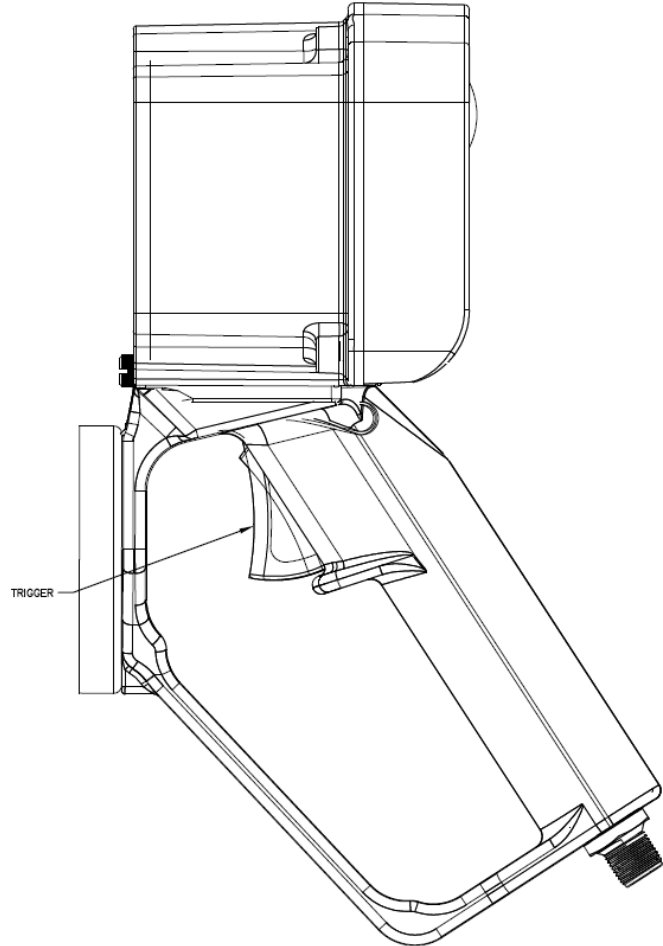
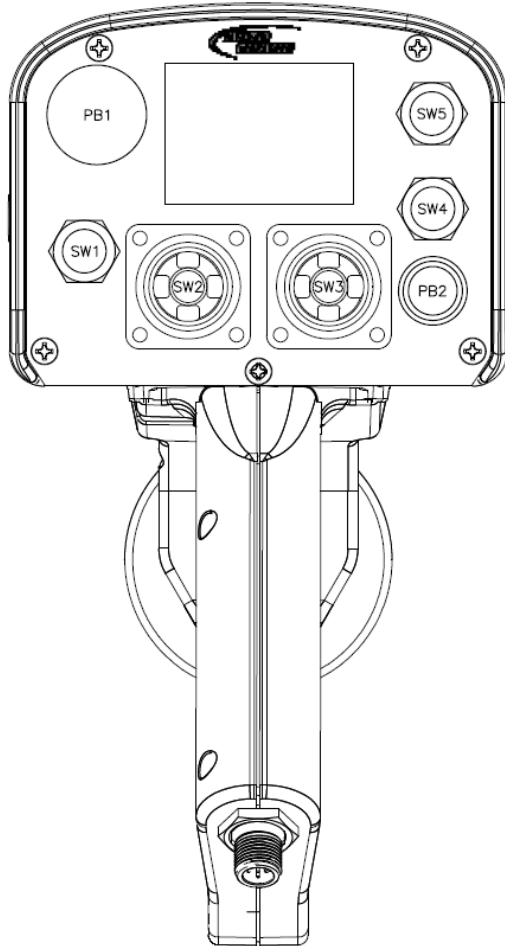

TURNING OFF TRANSMITTER— Move <SW5> to the “off” position

TURNING ON TRANSMITTER— Move <SW5> to the “on position” , Press and release <SW5> into the link position. Once the transmitter comes to the main screen move <SW5> to the “Link” position again.

ACTIVATING E-STOP

Press the E-stop Switch.

Note:













1. When E-stop is active, the transmitter will remain on but will not operate any functions. This includes truck and crane functions.
2. **Activating E-stop will not turn the truck off.**
3. There will be an Error Code on the receiver stating “E-stop active”.

DEACTIVATING E-STOP

1. Pull to release E-stop.
2. Turn transmitter to the “OFF” position.
3. Once the screen goes out. Turn transmitter back on. Reference “Turning transmitter on” procedures

NEXSTAR III CRANE OPERATION

TRANSMITTER LAYOUT

LABEL	DIRECTION	FUNCTION	GRAPHIC	DESCRIPTION
SW1	Up	Engine Start		Sends a 12VDC signal from crane to start vehicle
	Down	Engine Stop		Sends a 12VDC signal from crane to stop vehicle
SW2	Up	Boom Up		Moving the joystick up activates boom up function
	Down	Boom Down		Moving the joystick down activates boom down function
	Left	Rotate CCW		Moving the joystick to the left activates counter-clockwise rotation function
	Right	Rotate CW		Moving the joystick to the right activates clockwise rotation function
SW3	Up	Hoist Up		Moving the joystick up activates hoist up function
	Down	Hoist Down		Moving the joystick down activates hoist down function
	Left	Boom Retract		Moving the joystick to the left activates the boom retract function
	Right	Boom Extend		Moving the joystick to the right activates the boom extend function
SW4	Up	Auxiliary	AUX	Sends a Latching signal that activates an auxiliary output to operate an external component (i.e. compressor, worklights)
	Down	High Idle	HIGH IDLE	Sends a latching signal that activates High Idle on Vehicle
SW5	Up	Link, Speed & Mode Adjustment	Link	Links transmitter to crane (Press & Release) Access to the Speed & Mode Selection Screen (Press & Hold)
	Center	On		Transmitter is on*
	Down	Off	Off	Turns off Transmitter
PB1	In	E-stop Activated		Activates E-stop
	Out	E-stop Deactivated		Deactivates E-stop
PB2	In	Horn		Momentarily activates an audible signal device

* Although switch maybe in the "On" position doesn't necessarily mean there is communication between the transmitter and the crane. The transmitter goes to sleep after a certain amount of time. If the unit goes to sleep, the transmitter will need to be turned back on. Reference the steps under "Turning On Transmitter" if this occurs.

NEXSTAR III CRANE OPERATION

TRANSMITTER LAYOUT

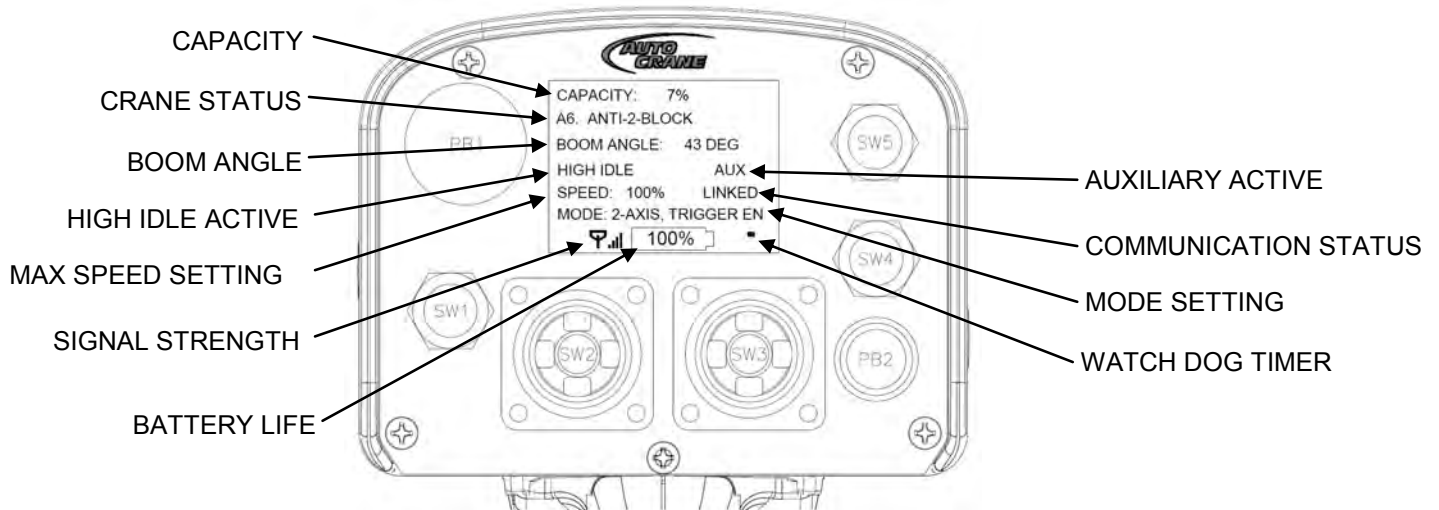

CAPACITY—Current percent of crane capacity used. **Note: Unloaded this value may be higher than 0% due to boom weight beyond the retracted position.**

CRANE STATUS—shows current status of the crane. If any alarms are occurring they will be displayed here. **Note: Reference Troubleshooting section for alarm descriptions.**

BOOM ANGLE (DEGREES) - Current boom angle in degrees. **Note this value may not match the boom angle decal attached to side of boom since the decal is referenced to the ground not the pedestal.**

HIGH IDLE ACTIVE—Shown only when the high idle function is active

MAX SPEED SETTING — Current max speed setting. Reference speed selection section for details and changing procedures.

TRANSMITTER SIGNAL STRENGTH—Shows the strength of signal coming from transmitter. **Note: approx. distance of transmitter is 300 feet.**

BATTERY LIFE—Percent of transmitter battery life remaining

WATCH DOG TIMER— Should always be moving in a diagonal. If timer stops moving contact your AutoCrane representative

MODE SETTING— Current mode setting. Reference Mode Selection section for changing procedures. Reference Mode Description section for details about different modes.

COMMUNICATION STATUS— Will display “Linked” when the transmitter is communicating with the crane. Toggle <SW5> up and release to establish a link between the crane and transmitter.

AUXILIARY ACTIVE— Shows when the auxiliary function is active.

NEXSTAR III CRANE OPERATION

SPEED/MODE SELECTION

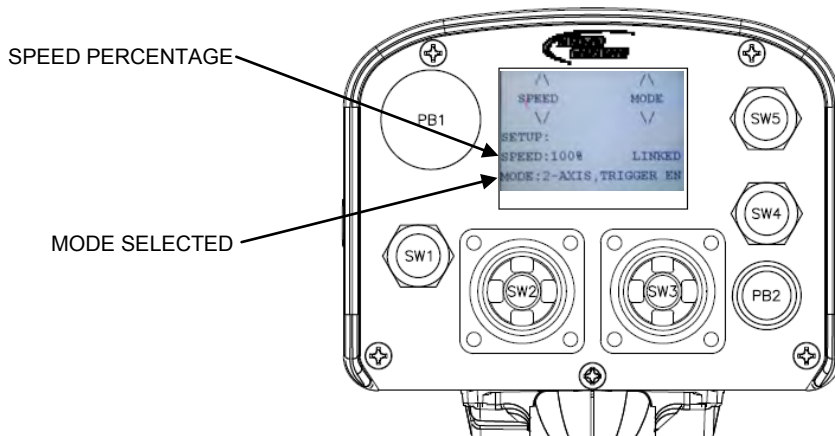

SPEED SELECTION

1. Press and hold <SW5> in the up position. (Screen above will be visible when <SW5> is held in up position)
2. While holding the <SW5> switch, move the <SW2> joystick in the up position to increase max speed or move the <SW2> joystick in the down position to decrease max speed.
3. Release <SW5> switch once the desired speed is selected.

Note:

1. Slower speed decreases the max speed and gives more finite control of the proportional joystick/trigger.
2. Faster speed increases the max speed but gives less finite control over the load.
3. The speed percentage on the screen will show the current speed setting of the transmitter.

MODE SELECTION

1. Press and hold <SW5> in the up position. (Screen above will be visible when <SW5> is held in up position)
2. While holding the <SW5> switch, move the <SW3> joystick in the up or down position to change modes.
3. Release <SW5> switch once the desired mode is selected.

MODE DESCRIPTIONS

1-AXIS, TRIGGER PROP

Allows only one function to operate on each joystick. The joysticks are on-off and just need to be moved in the direction of the function to operate. The speed control is located in the trigger. The more you depress the trigger, the faster the function and/or functions will go.

2-AXIS, TRIGGER PROP

Allows two functions to operate on each joystick. The joysticks are on-off and just need to be moved in the direction of the function to operate. The speed control is located in the trigger. The more you depress the trigger, the faster the function and/or functions will go.

1-AXIS, TRIGGER EN

Allows only one function to operate on each joystick. The speed control is located on the joystick. The more you move the joystick in the direction of the function, the faster the function will go. The trigger must be depressed for the functions to operate.

2-AXIS, TRIGGER EN

Allows two functions to operate on each joystick. The speed control is located on the joystick. The more you move the joystick in the direction of the function, the faster the function will go. The trigger must be depressed for the functions to operate.

NOTE: In 1-Axis operation - Once the joystick is moved in a direction, it locks out all remaining directions. For example: If you are booming up, you cannot rotate at the same time. You can, however, hoist up at the same time.

In 2-Axis operation - Allows the joystick to be up/down and left/right at the same time. For example: You can boom up slow and rotate CCW quickly but pushing up a little bit and moving to the far left at the same time.

TRANSMITTER SYNCHRONIZATION INSTRUCTIONS

1. The receiver must be shut off and powered down. The current address tag must be removed from the harness and the LEARN tag (366823955) will need to be put in its place.
2. After the LEARN tag has been put into place and the receiver is powered up, it will begin to search for the proper Channel and Serial Number of the transmitter. **Note: The transmitter must be powered up and the start/speed button must be held in the “speed” position. Make sure the transmitter is blinking the amber led in the center. Reference figure 1 below for LCD screen display during this step. Reference figure 2 below for transmitter switch position.**

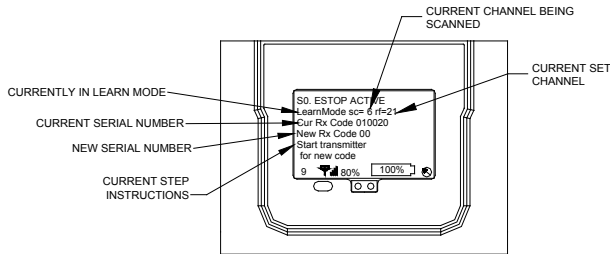

Figure 1—LCD screen display during step 2

Figure 2—Transmitter Switch Position

3. The receiver will start searching to find the channel and Serial Number. Once the numbers are found, it will display it on the LCD screen and will state “Press <Function> to confirm code”. At this time, release “speed position” and press then release the function shown on the screen. In the example below, press and release the Swing Clockwise function. Reference figures below:

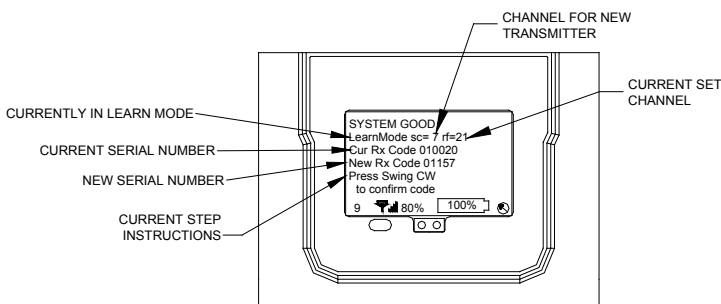

Figure 3—LCD screen display & transmitter during step 3

4. Once the code is confirmed, remove the LEARN tag from the harness. Then power the receiver off (main crane power switch) - reference figure 5

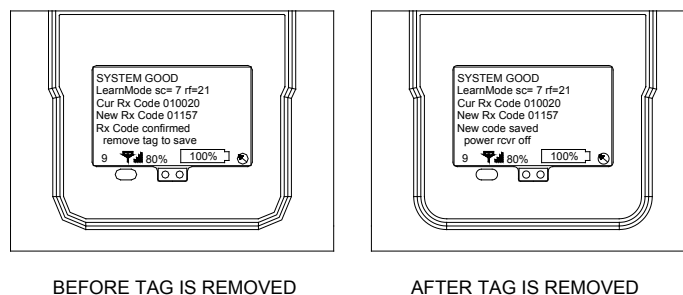

Figure 5 - LCD screen display during step 4

5. Re-attach the crane address tag to the harness and power up receiver. Confirm all functions are operational. **Note: If the LEARN tag was not removed before powering down the receiver, the new channel and serial number will not be saved.**

INSPECTION REQUIREMENTS

REFERENCE ASME B30.5a AND OSHA 1910.180 FOR COMPLETE INSPECTION REQUIREMENTS

INSPECTION CLASSIFICATION

1. Initial inspection.
Prior to initial use, all new, altered, modified or extensively repaired cranes shall be inspected by a designated person to insure compliance with provisions of this standard
2. Regular inspection.
Inspection procedure for cranes in regular service is divided into two general classifications based upon the intervals at which inspection should be performed. The intervals in turn are dependent upon the nature of the components of the crane and the degree of their exposure to wear, deterioration, or malfunction. The two general classifications are herein designated as "frequent" and "periodic" with respective intervals between inspections as defined below.
 - A. Frequent inspection - daily or before each use
 - B. Periodic inspection - one to twelve-month intervals or as specifically recommended by the manufacturer or qualified person.
6. Inspect for proper rope reeving.
7. Inspect electrical wiring and components for malfunctioning, signs of excessive deterioration, dirt and moisture accumulation.
8. Inspect hydraulic system for proper oil level and leaks.
9. Inspect tires for recommended inflation pressure, cuts and loose wheel nuts.
10. Inspect connecting pins and locking device for wear damage and loose retaining bolts.
11. Inspect rope for gross damage, such as listed below, which may be an immediate hazard.
 - A. Distortion such as kinking, crushing, un-stranding, birdcaging, main strand displacement, or core protrusion. Loss of rope diameter in a short length or unevenness of outer strands should be replaced.
 - B. General corrosion.
 - C. Broken or cut strands.
 - D. Use care when inspecting sections of rapid deterioration around flange points, crossover points, and repetitive pickup points on drums.
 - E. Inspect number, distribution, and type of visible broken wires. Reference Rope Maintenance section in the owner's manual.

DESIGNATED PERSONNEL SHALL PERFORM INSPECTIONS ONLY.

FREQUENT INSPECTION

Inspections should also occur during operation for any deficiencies that might appear between regular inspections. Any deficiencies, such as those listed below, shall be carefully examined and a determination made as to whether they constitute a hazard:

1. Inspect control mechanisms for maladjustment that interferes with proper operation.
2. Inspect control mechanisms for excessive wear of components and contamination by lubricants or other foreign matter.
3. Inspect safety devices for malfunction.
4. Visually inspect all hydraulic hoses, particularly those that flex in normal operation of crane functions.
5. Inspect hooks and latches for deformation, chemical damage, cracks, and wear. Refer to ANSI/ASME B30.10.

Continued use of rope depends upon good judgment by a designated person in evaluating remaining strength in a used rope after allowance for deterioration disclosed by inspection. Continued rope operation depends upon this remaining strength.

PERIODIC INSPECTION

Any deficiencies, such as those listed below, shall be carefully examined and determination made as to whether they constitute a hazard:

1. Inspect for deformed, cracked or corroded members in the crane structure and entire boom.
2. Inspect for loose bolts, particularly mounting bolts.
3. Inspect for cracked or worn sheaves and drums.
4. Inspect for worn, cracked, or distorted parts such as pins, bearings, shafts, gears, rollers and devices.
5. Inspect for excessive wear on brake and clutch system parts and lining.

INSPECTION REQUIREMENTS

6. Inspect crane hooks for cracks.
7. Inspect travel steering, braking, and locking devices for malfunction.
8. Inspect for excessively worn or damaged tires.
9. Inspect hydraulic hose, fittings, and tubing for the following problems:
 - A. Evidence of leakage at the surface of the flexible hose or its junction with metal and coupling.
 - B. Blistering, or abnormal deformation to the outer covering of the hydraulic or pneumatic hose.
 - C. Leakage at threaded or clamped joints that cannot be eliminated by normal tightening or recommended procedures.
 - D. Evidence of excessive abrasion or scrubbing on the outer surface of a hose, rigid tube, or fitting. Means shall be taken to eliminate the interference of elements in contact or otherwise protect the components.
10. Inspect hydraulic pumps and motors for the following problems:
 - A. Loose bolts and fasteners.
 - B. Leaks at joints between sections.
 - C. Shaft seal leaks.
 - D. Unusual noises or vibrations.
 - E. Loss of operating speed.
 - F. Excessive heating of the fluid.
 - G. Loss of pressure.
11. Inspect hydraulic valves for the following problems:
 - A. Cracks in valve housing.
 - B. Improper return of spool to neutral position.
 - C. Leaks at spools or joints.
 - D. Sticking spools.
 - E. Failure of relief valves to attain or maintain correct pressure setting.
 - F. Relief valve pressure shall be checked as specified by the manufacturers.
12. Inspect hydraulic cylinders for the following problems:
 - A. Drifting caused by fluid leaking across piston.
 - B. Rod seals leaking.
 - C. Leaks at welding joints.
 - D. Scored, nicked, or dented cylinder rods.
 - E. Damaged case (barrel).
 - F. Loose or deformed rod eyes or connecting joints.
13. Inspect hydraulic filters for evidence of rubber particles on the filter elements indicating possible hose, "O" ring, or other rubber component deterioration. Metal chips or pieces on the filter may denote failure in pumps, motors, or cylinders. Further inspection will be necessary to determine the origin of the problem before corrective action can be taken.
14. Inspect labels to confirm correct location and legibility. Reference decal layout in this manual for proper location of decals.
15. **Rope Inspections need not be at equal calendar intervals and should be more frequent as the rope approaches the end of useful life.** A qualified person shall inspect the wire rope based on such factors as:
 - A. Expected rope life as determined by experience on the particular installation or similar installations.
 - B. Severity of environment.
 - C. Percentage of capacity lifts.
 - D. Frequency rates of operation.
 - E. Exposure to shock loads.

This inspection shall cover the entire length of the rope. Only the surface wires need to be inspected and no attempt should be made to open the rope. Any deterioration resulting in appreciable loss of original strength shall be noted and determination made as to whether use of the rope would constitute a hazard. A few notable deterioration points are listed below:

 - A. Reduction of rope diameter below nominal diameter due to loss of core support.
 - B. Internal or external corrosion.
 - C. Wear of outside wires.
 - D. Severely corroded, cracked, bent, worn, or improperly applied connections.

CRANES NOT IN REGULAR USE

A crane, which has been idle for a period of over one month or more, shall be given an inspection conforming to the "initial" and "regular" inspection requirements of this section.

INSPECTION RECORDS

Dated records of periodic inspection should be made on critical items such as brakes, crane hooks, rope, cylinders, and relief pressure valves.

TESTING REQUIREMENTS

REFERENCE ASME B30.5a AND OSHA 1910.180 FOR COMPLETE INSPECTION REQUIREMENTS

TESTING SHALL BE PERFORMED BY DESIGNATED PERSONNEL ONLY.

Prior to initial use, all new, altered, modified, or extensively repaired cranes shall be tested for compliance with the operational requirements of this crane.

Test requirements:

1. Test all functions to verify speed and operation.
2. Check that all safety devices are working properly.
3. Confirm operating controls comply with appropriate function labels.
4. Test loads shall not exceed 110% of the manufacturer's load rating.
5. Written reports shall be maintained showing test procedures and confirming the adequacy of repairs

GENERAL REPAIRS AND MAINTENANCE

REFERENCE ASME B30.5a AND OSHA 1910.180 FOR COMPLETE MAINTENANCE AND REPAIR REQUIREMENT

A preventative maintenance program should be established based on this section and all replacement parts should be obtained from AutoCrane Company. For replacement parts contact your local authorized distributor.

MAINTENANCE PRECAUTIONS

1. Place crane where it will cause the least interference with other equipment or operations.
2. Verify all controls are in the "off" position and all operating features secured from inadvertent motion by brakes, pawls, or other means.
3. The means for starting the crane shall be rendered inoperative.
4. The boom should be secured in place before maintenance.
5. Relieve hydraulic oil pressure from all hydraulic circuits before loosening or removing hydraulic components.
6. Warning or "OUT OF ORDER" signs shall be placed on all crane controls.
7. After adjustments and repairs have been made, the crane shall not be returned to service until all guards have been reinstalled, trapped air removed from hydraulic system (if required), safety devices reactivated, and maintenance equipment removed.

ADJUSTMENTS AND REPAIRS

1. Any hazardous conditions disclosed by the inspection requirements shall be corrected before operation of crane is resumed. Only designated personnel shall do adjustments and repairs.
2. Adjustments shall be maintained to assure correct functioning of components, the following are examples:
 - A. Functional operating mechanism.
 - B. Safety devices.
 - C. Control systems.
3. Repairs or replacements shall be provided as needed for operation, the following are examples:
 - A. Critical parts of functional operating mechanisms which are cracked, broken, corroded, bent, or excessively worn.
 - B. Critical parts of the crane structure which are cracked, bent, broken, or excessively corroded.

C. Crane hooks showing cracks, damage, or corrosion shall be taken out of service. Repairs by welding are not recommended.

4. If bleeding the hydraulic system is required, run each crane function until smooth operation of that particular function is noticeable.

LUBRICATION

All moving parts of the crane, for which lubrication is specified, should be regularly lubricated per the manufacturer's recommendations and procedures. Reference Lubrication and Maintenance Schedule in this manual.

ROPE REPLACEMENT

No precise rules can be given for determination of the exact time for replacement of rope, since many variable factors are involved.

1. Conditions such as the following shall be reason for questioning continued use of the rope or increasing the frequency of inspection:
 - A. In running ropes, six randomly distributed broken wires in one lay or three broken wires in one strand in one lay.
 - B. One outer wire broken at the contact point with the core of the rope structure and protrudes or loops out of the rope structure. Additional inspection of this section is required.
 - C. Wear of one third of the original diameter of the outside individual wire.
 - D. Kinking, crushing, bird caging, or any other damage resulting in distortion of the rope structure.
 - E. Evidence of any heat damage from any cause.
 - F. Reduction from nominal diameter of more than 1/64 in. (0.4mm) for diameters up to and including 5/16 in. (8 mm), 1/32 in. (0.8 mm) for diameter 3/8 in. (9.5 mm) to and including 1/2 in. (13 mm), 3/64 in. (1.2 mm) for diameter 9/16 in. (14.5 mm) to and including 3/4 in. (19 mm), 1/16 in. (1.6 mm) for diameter 7/8 in. (22 mm) to and including 1-1/8 in. (29 mm), 3/32 in. (2.4 mm) for diameters 1-1/4 in. (32 mm) to and including 1-1/2 in. (38 mm).
 - G. In standing ropes, more than two broken wires in one lay in sections beyond end connections or more than one broken wire at an end connection.

GENERAL REPAIRS AND MAINTENANCE

2. Replacement rope shall have a strength rating at least as great as the original rope furnished or recommended by AutoCrane. A rope manufacturer, AutoCrane, or a qualified person shall specify any deviation from the original size, grade, or construction.

ROPE MAINTENANCE

1. Rope should be stored to prevent damage or deterioration.
2. Unreeling or uncoiling of rope shall be done as recommended by the rope manufacturer and with care to avoid kinking or inducing twist.
3. Before cutting a rope, seizing shall be placed on each side of the place where the rope is to be cut to prevent unlaying of the strands. On pre-formed rope, one seizing on each side of the cut is required. On non-preformed ropes of 7/8 in. (22 mm) diameter or smaller, two seizings on each side of the cut are required, and for nonpre-formed rope 1 in. (25 mm) diameter or larger, three seizings on each side of the cut are required.
4. During installation care should be exercised to avoid dragging of the rope in the dirt or around objects that will scrape, nick, crush, or induce sharp bends in it.
5. Rope should be maintained in a well-lubricated condition. It is important that lubricant applied as a part of a maintenance program shall be compatible with the original lubricant and to this end the rope manufacturer should be consulted. Lubricant applied shall be the type that does not hinder visual inspection. Those sections of rope that are located over sheaves or otherwise hidden during inspection and maintenance procedures require special attention when lubricating rope. The object of rope lubrication is to reduce internal friction and to prevent corrosion.
6. When an operating rope shows greater wear or well-defined localized areas than on the remainder of the rope, rope life can be extended in some cases by shifting the wear to different areas of the rope.

MAINTENANCE OF BATTERIES

Maintenance of Auto Crane unit batteries differs very little from the generally prescribed maintenance of any lead acid battery. All batteries must be kept properly charged, properly filled with water, and relatively clean.

Keep Properly Charged

Many things affect the proper charge to a battery, such as:

1. Regulator settings.
2. Proper tightness of belts on the alternator or generator.
3. Good, clean connections of all cables and wires at the following places:
 - a. Battery.
 - b. Regulator.
 - c. Starting motor.
 - d. Alternator or generator.
 - e. Ground connections (most important).

It is of extreme importance to keep the battery as fully charged as possible without overcharging, especially when vehicles are left outside for extended periods in extremely cold climates. A battery can freeze. Freezing points for various specific gravities of acid are as follows:

Specific Gravity (Corrected to 80°F)	Freezing Temp. Degrees F.
1.280	-90°F
1.250	-62°F
1.200	-16°F
1.150	5°F
1.100	19°F

As shown, a half-charged battery (about 1.100 specific gravity) cannot stand for any length of time at 20°F or it will freeze.

The main reason for keeping the battery as fully charged as possible without over-charging is to insure that power is available even though the vehicle has been standing for some time.

Keep Properly Filled with Water

The battery should *always* be properly filled with water. If the electrolyte level is allowed to fall below the top of the plates, the results become threefold:

1. The exposed portion of the plate will become sulfated.

2. The portion of the plate exposed is not usable.
3. That portion of the acid remaining becomes more concentrated and may cause more rapid deterioration of the remaining parts of the battery.

Keep A Relatively Clean Battery

The battery should be kept clean. Batteries filled with acid and which are not in use self-discharge to a limited degree because of the nature of the materials within the battery. If dirt is allowed to collect on the top of the battery (and this dirt absorbs moisture) and electrical path can be set up between the various terminals of the battery and the ground. Once such a path has been established, the self-discharge of the battery is accelerated. This also accelerates corrosion of the battery cables at the terminals.

Periodic Maintenance is Needed

A definite program of periodic maintenance of all batteries should be conducted on a regular basis. Periodic maintenance includes:

1. Checking belts for tightness on the charging equipment.
2. Checking battery electrolyte levels.
3. Checking cables for good connections.
4. Cleaning where corrosion is apparent.

When corrosion is cleaned off, the cable terminals and battery terminals should be coated with a light coating of petroleum jelly before they are replaced. When terminals are cleaned, the top of the battery should be cleaned with a mild solution of soda water.

Low Maintenance Batteries (Maintenance Free)

Low maintenance batteries should not be used on AutoCrane Cranes or trucks equipped with Auto-Crane Cranes. The batteries are not designed for "deep" discharge.

Testing Your Battery

If the condition of the battery is in question, it should be removed from the vehicle, taken to the shop, and allowed to reach room temperature. It should then be recharged until specific gravity readings taken at one-half hour intervals. If the specific gravity readings are fairly uniform, the battery should be checked with a high rate tester. Use the tester in accordance with the manufacturer's instructions. The high rate tester is the best method to test a questionable battery.

MAINTENANCE OF BATTERIES

If, after charging, it is noted that the specific gravity reading of one cell is 30 points less than any of the other cells, it may be assumed that the cell is bad and that the battery should be replaced. If all cells are uniform but not up to full charge, a low rate of charge should be attempted for an extended time. This usually will recover a badly sulfated battery.

Replacing a Battery

If it is necessary to replace a battery, and a dry charge battery is used, the following procedure applies:

1. Fill the battery with electrolyte of the proper specific gravity.

2. Place the battery on charge according to the manufacturer's instructions.

It is essential that the second step above be followed to ensure that the battery going on the vehicle is fully charged.

It is also very important that the battery hold-downs be checked periodically to insure that the batteries are properly positioned to avoid vibration problems, breakage of cables or terminals. Care must be taken to avoid cracking or breaking containers or covers by tightening hold-down fixtures excessively. They also must not be so loose that breakage results from a hold-down that is too loose.

HC-5 LUBRICATION & MAINTENANCE SCHEDULE

SERVICE PERFORMED	DAY	WKLY	3 MOS	6 MOS	YEAR	NOTES
LOAD HOOK	X					INSPECT HOOK & LATCH FOR DEFORMATION, CRACKS, & CORROSION
CABLE DRUM	X					MAKE SURE CABLE IS WOUND EVENLY ON DRUM
HOIST / BOOM CABLE	X					CHECK FOR FLATTENING, KINKS, & BROKEN STRANDS, SEE MANUAL
HYD. HOSES	X					VISUAL INSPECTION
HYD. FLUID	X					CHECK FLUID LEVEL
PIN RETAINING BOLTS	X					CHECK TORQUE TO 23 FT-LBS (GRADE 5), 35 FT-LBS (GRADE 8) AS REQUIRED
MOUNTING BOLTS		X				CHECK TORQUE TO 501 FT-LBS AS REQUIRED
ROTATION RING GEAR		X				LUBE WITH MOBILETAC LL, OR LUBRIPLATE P/N 15263, OR EQUAL
SHEAVE BEARINGS		X				SEALED BEARING, REPLACE IF ROUGH OR LOOSE
ALL OTHER BOLTS		X				CHECK TIGHTEN AS REQUIRED
LIFT CYLINDER BEARINGS			X			GREASE WITH MOBILEPLEX EP-2 OR EQUIVALENT @ ZERKS
ROTATION BEARING			X			GREASE WITH MOBILEPLEX EP-2 OR EQUIVALENT @ ZERKS
ROTATION BEARING BOLTS			X			CHECK TORQUE TO 170 FT-LBS (HEX HEAD) 180 FT-LBS (SOCKET HEAD) AS REQUIRED
ROTATION GEAR BOX			X			CHECK TORQUE TO 90 FT-LBS (SOCKET HEAD) AND 55 FT-LBS (HEX HEAD) AS REQUIRED
ROTATION GEAR BOX				X		EP GEAR LUBE SAE 80-90
HYDRAULIC FLUID					X	DRAIN, FLUSH, AND REFILL WITH MOBILE DTE 13 OIL
BOOM SLIDE PADS	PADS GREASED WHEN REPLACED					
FILTER, VALVE BLOCK	REPLACE ANNUALLY OR EVERY 200 HOURS OF OPERATION. AS DIRECTED BY DIRTY FILTER SENSOR (NEXSTAR II ONLY)					
FOR ADDITIONAL INFORMATION SEE:	1) OWNER'S MANUAL 2) OSHA SECTION 1910.180 3) ANSI B30.5-1989					

CAUTION: Routine maintenance insures trouble-free operation and protects your investment. All warranties are void if maintenance is neglected.

HC-5

LUBRICATION & MAINTENANCE SCHEDULE

NOTES:

1. Use only authorized parts. Any damage or malfunction caused by the use of unauthorized parts is not covered by Warranty or Product Liability.
2. Once a bolt has been torqued to its rated capacity and then removed; the bolt should be replaced with a new one.
3. Auto Crane Company recommends that this crane be serviced per "Crane Inspection Log" P/N 999978. These logs should be filled in at the intervals noted and kept as a permanent record. Additional copies are available from your local distributor.

LUBE POINTS

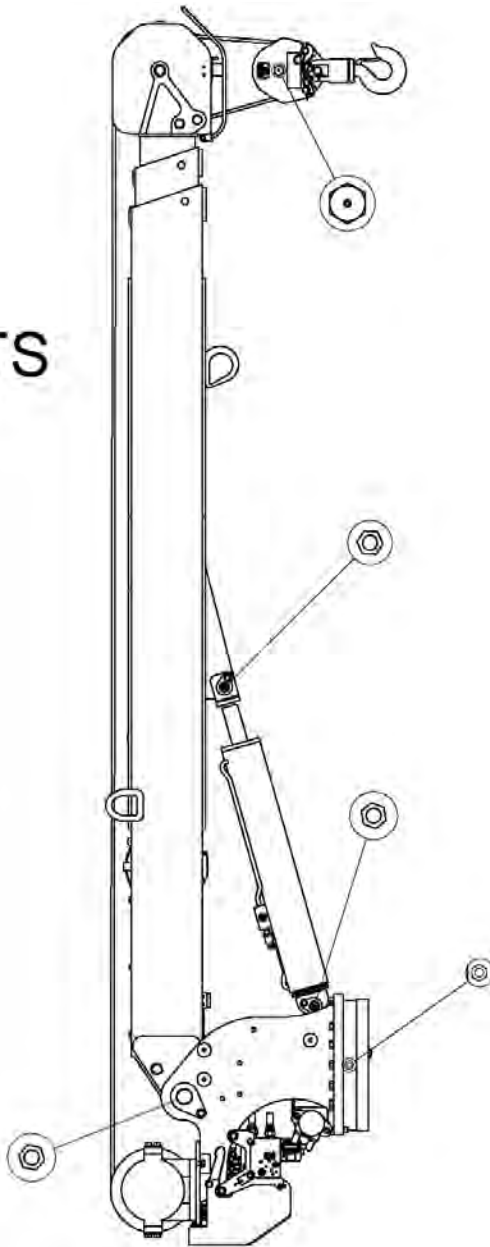

ROTATION BEARING REPLACEMENT GUIDELINES - 5005 THRU 8406

All bearings can wear over time. This includes the main rotation bearing on the crane. No precise rules can be given for replacement of the rotation bearing, since many factors are involved. However, there are common symptoms seen during crane operation that may be caused by rotation bearing wear. These symptoms include:

1. Excessive Noise
2. Rough rotation
3. Increased drive power required to rotate.
4. Metal particles in grease

REASONS FOR ROTATION BEARING REPLACEMENT

1. Any noticeable cracking in the bearing housing
2. Damage to internal teeth
3. Excessive axial play (reference axial play check instructions below)

WARNING—NEVER TRY TO REPAIR A ROTATION BEARING. FOR A REPLACEMENT BEARING CONTACT YOUR LOCAL AUTHORIZED DISTRIBUTOR.

AXIAL PLAY ALLOWANCE CHECK PROCEDURE

1. Boom up to the max boom angle and measure the clearance between base plate and the rotation bearing with a dial or filler gauge. Reference figure 1 for location.
2. Boom down to the horizontal position and measure the clearance between the base plate and the rotation bearing with a dial indicator or feeler gauge. Reference figure 1 for location.
3. If the difference between the two measurements exceeds 1/16 inch, replace bearing.
4. Rotate crane 45 degrees then repeat steps above until you reach 360 degrees of rotation.

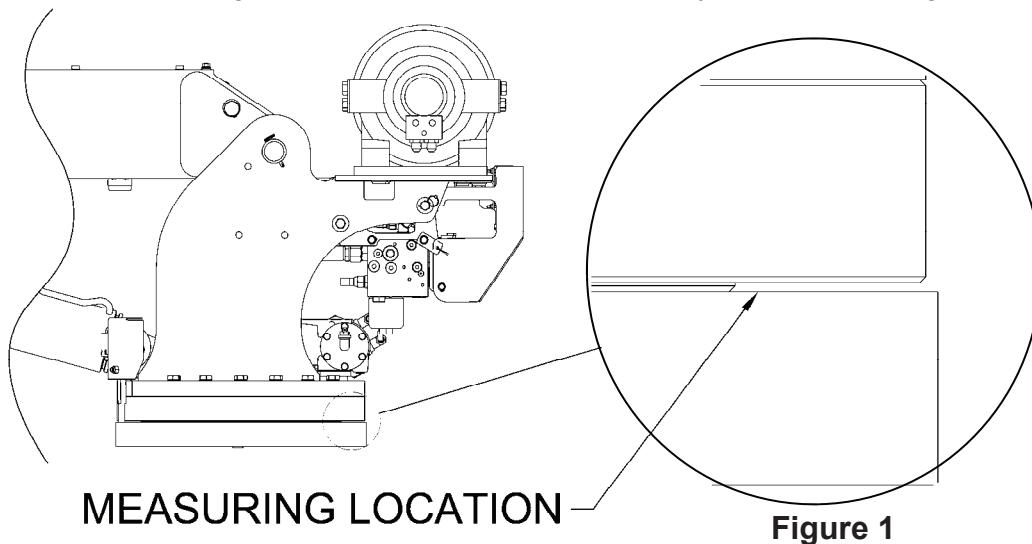

Rotation bearing replacement kit part number is 480023010

WARNING—WHEN REPLACING ROTATION BEARING, USE NEW HARDWARE WHICH IS INCLUDED IN THE KIT ABOVE.

HC-5 SAFETY DECAL

PART NO.:	040579000
DECAL:	OPERATING INSTRUCTIONS
FUNCTION:	To inform the operator of the proper procedure to follow for safe operation of the crane.
USED ON:	All Cranes
QUANTITY:	1
PLACEMENT:	Left side plate

⚠ CAUTION

1. INSPECT VEHICLE AND CRANE INCLUDING OPERATION, PRIOR TO USE DAILY.
2. DO NOT USE THIS EQUIPMENT EXCEPT ON SOLID, LEVEL SURFACE WITH OUTRIGGERS PROPERLY EXTENDED AND CRANE MOUNTED ON FACTORY-RECOMMENDED TRUCK.
3. BEFORE OPERATING THE CRANE, REFER TO MAXIMUM LOAD (CAPACITY) CHART ON CRANE FOR OPERATING (LOAD) LIMITATIONS.
4. OPERATE ALL CONTROLS SLOWLY AND SMOOTHLY.
5. KEEP LOAD UNDER BOOM TIP. DO NOT SIDE LOAD BOOM OR DRAG LOADS. AVOID FREE SWINGING LOADS.
6. DO NOT OPERATE, WALK OR STAND BENEATH BOOM OR A SUSPENDED LOAD.
7. KEEP AT LEAST 5 WRAPS OF LOADLINE ON HOIST DRUM.
8. FOR TRAVELING, BOOM AND OUTRIGGERS MUST BE IN THE STOWED POSITION.
9. ALL REMOVABLE PENDANTS MUST BE STORED IN CAB OR TOOL COMPARTMENT WHEN CRANE IS NOT IN USE.

P/N 040579

PART NO.:	040580000
DECAL:	OPERATING TRAINING
FUNCTION:	To inform the operator of the need to receive proper training before using the crane.
USED ON:	All Cranes
QUANTITY:	1
PLACEMENT:	Right side plate

⚠ DANGER

AN UNTRAINED OPERATOR
SUBJECTS HIMSELF AND
OTHERS TO

DEATH OR SERIOUS INJURY

- 1.) YOU MUST HAVE BEEN TRAINED IN THE OPERATION OF THIS CRANE, AND
- 2.) YOU MUST KNOW AND FOLLOW THE SAFETY AND OPERATING RECOMMENDATIONS CONTAINED IN THE MANUFACTURER'S MANUAL, YOUR EMPLOYER'S WORK RULES AND APPLICABLE GOVERNMENT REGULATIONS.

P/N 040580

PART NO.:	040632000
DECAL:	TAMPERING WITH OVERLOAD DEVICE
FUNCTION:	To inform the operator that tampering with the overload device may cause a unit failure or possible personal injury.
USED ON:	All Cranes equipped with a load sensor
QUANTITY:	1
PLACEMENT:	Right side plate

⚠ WARNING

TAMPERING WITH OVERLOAD DEVICE VOIDS WARRANTY. OVERLOADED CRANE MAY HYDRAULICALLY RELEASE AND LET LOAD DOWN TO GROUND. OVERLOAD PROTECTION DEVICE CANNOT FUNCTION WITH BOOM BELOW HORIZONTAL (0°). HOIST UP, BOOM DOWN, AND EXTEND OUT WILL BE INOPERATIVE WHEN CRANE IS IN OVERLOAD CONDITION.

P/N 040632

HC-5 SAFETY DECAL

PART NO.:	040529000
DECAL:	ELECTROCUTION HAZARD
FUNCTION:	To inform the operator of the hazard involved with contacting electrical power lines with crane boom.
USED ON:	All Cranes
QUANTITY:	2
PLACEMENT:	Both sides of end of lower boom

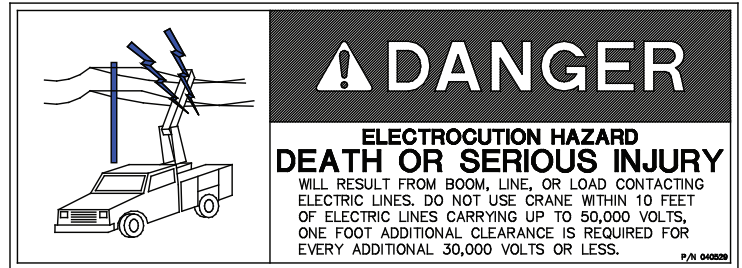

PART NO.:	040517000
DECAL:	STAY CLEAR OF BOOM
FUNCTION:	To inform the operator of the hazard of proximity or contact with the crane boom during operation.
USED ON:	All Cranes
QUANTITY:	2
PLACEMENT:	Both sides of crown

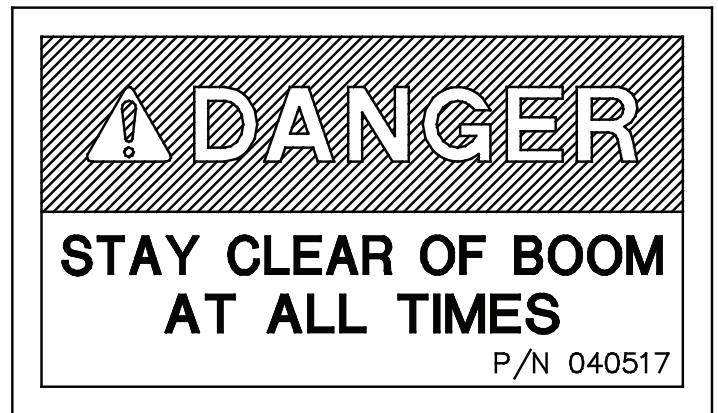

PART NO.:	040518000
DECAL:	STAY CLEAR OF LOAD
FUNCTION:	To inform the operator of the hazard of proximity or contact with the crane load during operation.
USED ON:	All Cranes
QUANTITY:	2
PLACEMENT:	Both sides of traveling block



HC-5 SAFETY DECAL

PART NO.:	040587000	USED ON:	All cranes equipped with a load sensor.
DECAL:	LOAD SENSOR, DON'T TAMPER	QUANTITY:	1
FUNCTION:	To inform the operator that the load sensor is pre-set and that tampering with the sensor may cause potentially hazardous situation.	PLACEMENT:	One side of the lift cylinder near the load sensor

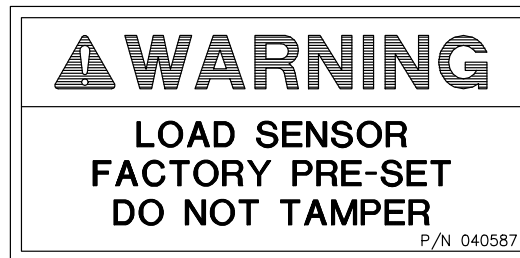

PART NO.:	040519000	USED ON:	All cranes.
DECAL:	SCISSORS POINT	QUANTITY:	2
FUNCTION:	To inform the operator of possible danger at scissors point on crane.	PLACEMENT:	Both sides of the lift cylinder

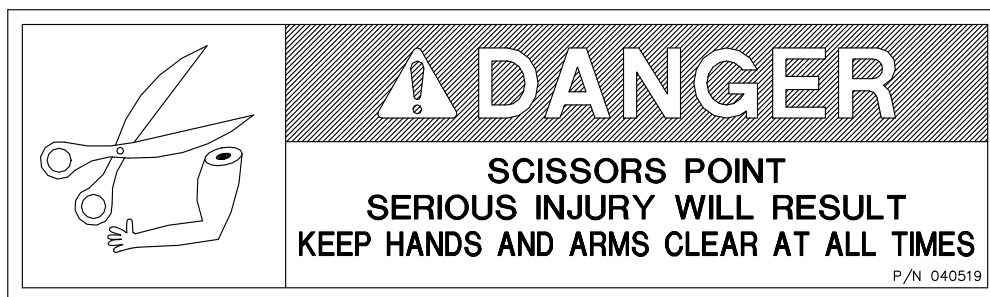

HC-5 SAFETY DECAL

PART NO.:	460169000	USED ON:	All Cranes equipped with FM controls.
DECAL:	REMOTE CONTROL	QUANTITY:	1
FUNCTION:	To inform the operator of failure to follow the safety precautions may result in equipment failure or serious personal injury.	PLACEMENT:	LEFT SIDE PLATE



WARNING

REMOTE CONTROL SAFETY PRECAUTIONS

READ THE OPERATOR'S MANUAL before using the Remote Control System. Failure to follow the safety precautions may result in equipment failure or serious personal injury.

MAKE SURE MACHINERY AND SURROUNDING AREA IS CLEAR BEFORE OPERATING REMOTE CONTROL SYSTEM. Do not activate the Remote Control System unless it is safe to do so.

TURN OFF THE RECEIVER POWER BEFORE WORKING ON THE MACHINE. Always disconnect the Remote Control System before doing any maintenance to prevent accidental operation of the machine.

DO NOT MODIFY EQUIPMENT WITHOUT WRITTEN APPROVAL FROM THE MANUFACTURER.

CARE

KEEP DRY. Do not clean the Transmitter / Receiver under high pressure. If water or other liquids get inside the Transmitter battery or Receiver compartment, immediately dry the unit. Remove the case and let the unit air dry.

Clean the unit after operation using a damp cloth to remove any mud, dirt, concrete, etc. from the unit and prevent clogging of buttons, switches, etc.

MAINTENANCE / WELDING

DISCONNECT THE RECEIVER BEFORE WELDING ON THIS MACHINE. Failure to disconnect will result in the destruction of the Receiver.

460169000 A

HC-5 DECAL LAYOUT NEXSTAR III

P/N: 361106541

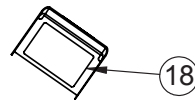
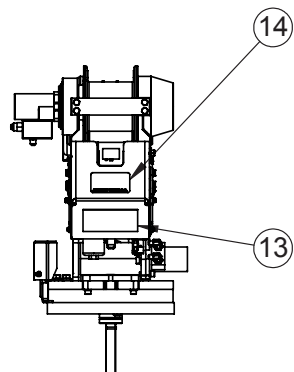
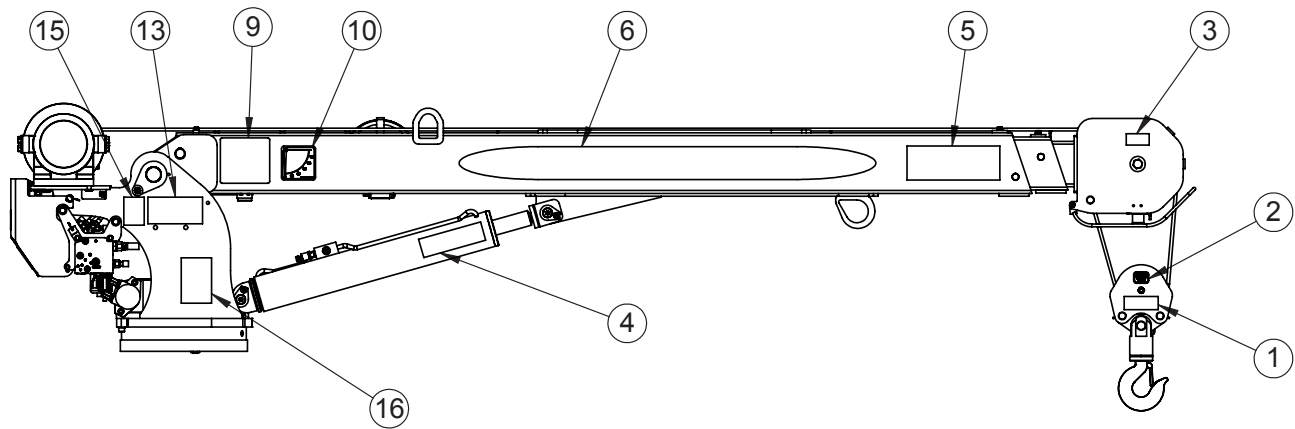
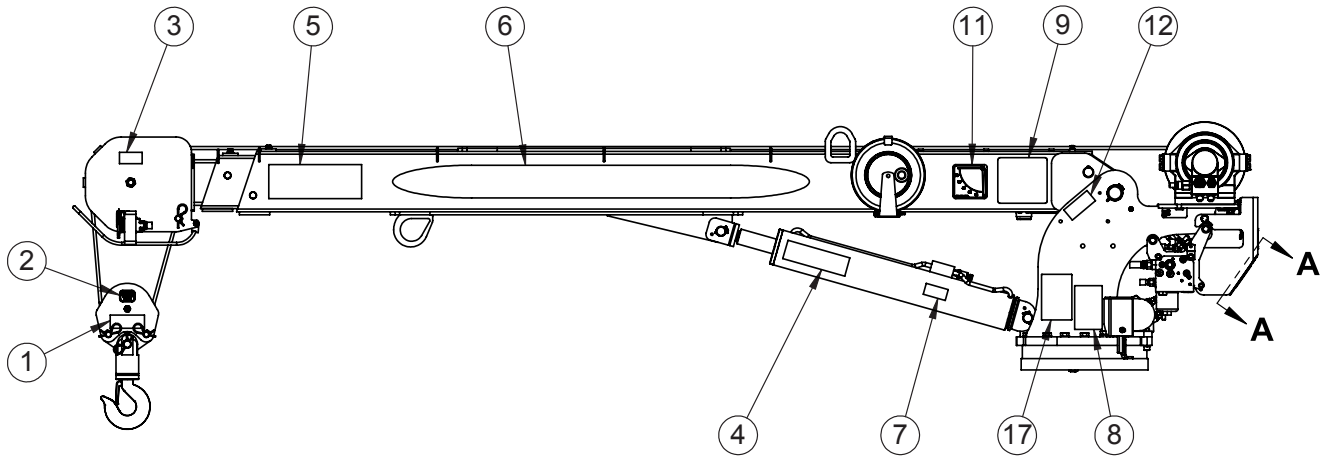

SECTION A-A

HC-5 DECAL LAYOUT NEXSTAR III

P/N: 361106541

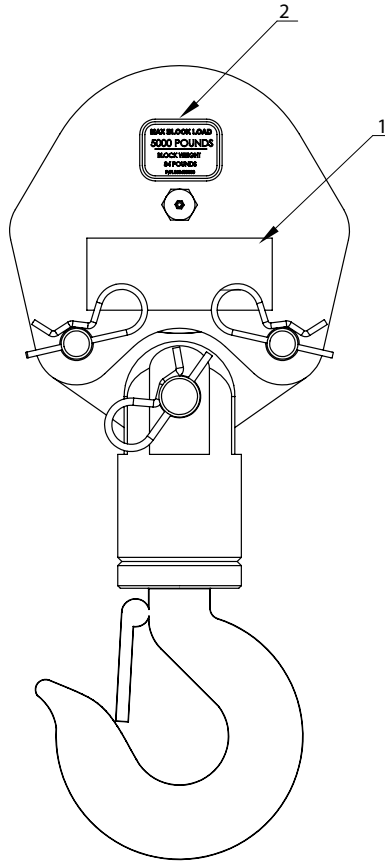

ITEM NO.	QTY	PART NUMBER	DESCRIPTION
1	2	040518	DECAL STAY CLEAR OF LOAD
2	2	360480100	DECAL, MAX LOAD BLOCK 5005H/EH
3	2	040517	DECAL STAY CLEAR OF BOOM
4	2	040519	DECAL DANGER SCISSOR POINT
5	2	040529	DECAL DANGER "ELECTROCUTION HAZARD" POWER LINE
6	2	361106523	DECAL, BOOM, HC-5, NEXSTAR
7	1	040587	DECAL WARNING LOAD SENSOR
8	1	040579	DECAL OPERATION INSTRUCTIONS
9	2	361106539	DECAL, LOAD CHART, HC-5
10	1	320318001	DECAL ANGLE INDICATOR SS
11	1	320318	DECAL ANGLE INDICATOR CS
12	1	330622	DECAL SERIAL NO
13	2	360034	DECAL AUTO CRANE LOGO
14	1	040824000	DECAL, AMERICAN FLAG, MADE IN THE U.S.A.
15	1	040632	DECAL WARNING - OVERLOAD
16	1	040580	DECAL TRAINED OPERATOR
17	1	460169000	DECAL WARNING, REMOTE CONTROL
18	1	366823302	DECAL, MAN OR PROCEDURES, GS HYD, LRG H-MODS, PUSH BUTTON

HC-5 NEXSTAR III GENERAL DIMENSIONS

NOTE: C.G. IS APPROXIMATE

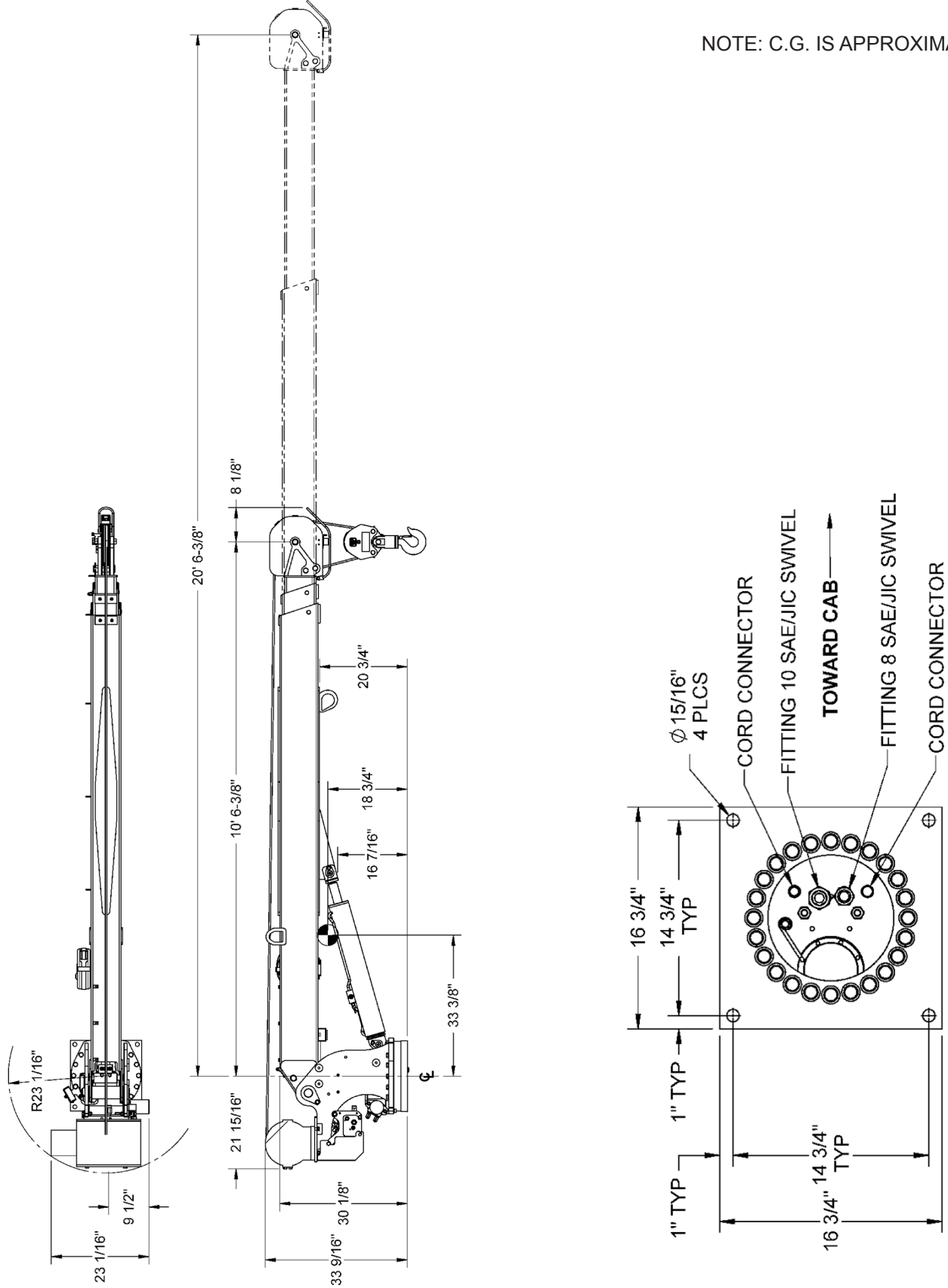

NOTES

HC-5 NEXSTAR III MOUNTING AND INSTALLATION

1. Check to make sure the following items are with your crane. Please note the different, model specific, quantities.

ITEM NO.	QTY.	PART NO.	DESCRIPTION
1	4	015100000	7/8-14 X 4 HH GR 8
2	4	022200000	WASHER SP LK 7/8
3	4	018900000	NUT HX 7/8 NFCP GR8
4	1	480689000	FUSE 15 AMP TIME-DELAY
5	1	480688000	FUSE HOLDER IN-LINE WATERPROOF
6	120 in	800596000	WIRE 16G 600V 1C YEL
7	6	634401000	WIRE TIE 7 INCHES LONG
8	6	750738000	WIRE TIE STICK ON RETAINER
9	5	320357000	CONNECTOR FEM POWER
10	1	340638000	CONDUCTOR POWER
11	1	320355000	POWER RELAY
12	1	320363000	PLUG RELAY
13	1	361106521	MANUAL, HC-5, FM, NEXSTAR III
14	1	361106539	DECAL, LOAD CHART, HC-5

2. Pressure and return hoses are not furnished with this crane. The hoses must be provided by the installer and the lengths determined at installation.

REQUIREMENTS FOR INSTALLATION

- A. **RETURN LINE** from crane to reservoir (in compartment) -10 SAE 100R2 (or equivalent). Hose length is determined by installer. **Return lines longer than 6 feet should be size -12.** Hose end fittings are

IMPORTANT: The recommended hydraulic reservoir size for the average industry application **CRANE ONLY** installation is two times the crane hydraulic flow rate. For crane applications requiring more than 25% crane operation time while the PTO is engaged and/or additional equipment is operated by the same hydraulic system, it is recommended that an appropriate sized larger hydraulic reservoir and/or forced air, hydraulic oil cooler be installed.

**CAUTION-FAILURE TO USE CLEAN HYDRAULIC HOSES AND COMPONENTS
MAY CONTAMINATE THE CRANE AND HYDRAULIC SYSTEM AND VOID
WARRANTY.**

3. Crane must be provided with a flow of 8 to 12 gallons per minute and a pressure of 2750 PSI. Excess flow will cause erratic operation, and too little flow will cause poor crane operation.

**CAUTION- HYDRAULIC RESERVOIR OIL TEMPERATURE MUST NOT EXCEED 180°F OR
CRANE PERFORMANCE MAY BE ADVERSELY AFFECTED.**

4. Vehicle should meet minimum GVW rating of 14,500 pounds.
5. The vehicle MUST be equipped with an engine speed control and tachometer.
6. Make sure mounting surface is properly reinforced to withstand 25,000 ft-lb capacity loading of crane and that outriggers are used to provide total stability for the truck.

NEXSTAR III

MOUNTING AND INSTALLATION

7. A 13 1/2" diameter hole should be cut out of mounting location (centered with mounting bolts) for access to hydraulic connections.
8. Make sure the mounting bolts are 7/8" dia, grade 8-UNF. Torque bolts to 501 ft-lbs.
9. When crane is not in operation, a boom support should always be used. Traveling block should be connected to hook loop.
10. Electrical hookup:
 - Wiring (FM – cable from base of crane):
 - A. CONNECT THE BLACK WIRE TO THE BATTERY NEGATIVE (GROUND).
 - B. CONNECT THE RED WIRE TO FUSED 12VDC POWER. 12VDC POWER SHOULD BE SUPPLIED THROUGH A DEDICATED SWITCH THAT IS POWERED ONLY WHEN THE IGNITION SWITCH IS ON.
 - C. OPTIONALLY, USE THE WHITE (OR BROWN) WIRE FOR ENGINE FAST/SLOW (12VDC MAINTAINED-FM ONLY).
 - D. OPTIONALLY, USE THE BLUE (OR YELLOW) WIRE FOR ENGINE START.
 - E. OPTIONALLY, USE THE ORANGE (OR GREEN) WIRE FOR ENGINE STOP.
 - F. OPTIONALLY, USE THE GREEN OR BLUE) WIRE FOR AUXILIARY (12VDC MAINTAINED-FM ONLY).NOTE: IF YOU HAVE A BROWN, USE THE COLORS IN PARENTHESES.

NOTE: ALL ELECTRICAL CONNECTIONS BETWEEN THE CRANE AND THE VEHICLE SHOULD BE MADE USING RELAYS TO ISOLATE THE ELECTRICAL SYSTEMS OF EACH AS MUCH AS POSSIBLE.

WARNING! FAILURE TO CORRECTLY PLUMB AND WIRE CRANE CAN CAUSE INADVERTENT OPERATION AND DAMAGE TO CRANE AND/OR PERSONNEL!

11. Once crane and plumbing are installed on the truck, fill the reservoir to top of sight glass (mobile DTE 13 or equal). Before operating crane, connect together the pressure and return hoses going to base of crane using 10-12 JIC union and engage PTO with engine running. Allow oil to circulate for 15 to 20 minutes. This will flush any contaminants from the system back to the return line filter. Operate all cylinders to full extension and retraction a minimum of six times, to bleed air from system. Return all cylinders to the stored position and disengage PTO. Refill reservoir to top sight glass. To ensure 8 gallons per minute (GPM), install an in-line flow meter between the crane and the reservoir in the return hose.
12. Load test the crane to ensure proper functioning and truck stability.
13. Make certain the owner's manual is delivered to the customer.
14. For additional help: call the service department at the Auto Crane Company (800) 777-2760 (Tulsa, Oklahoma).

WARNING

FEDERAL LAW (49 CFR PART 571) REQUIRES THAT THE FINAL STAGE MANUFACTURER OF A VEHICLE CERTIFY THAT HE VEHICLE COMPLIES WITH ALL APPLICABLE FEDERAL REGULATIONS. ANY MODIFICATIONS PERFORMED ON THE VEHICLE PRIOR TO THE FINAL STAGE ARE ALSO CONSIDERED INTERMEDIATE STAGE MANUFACTURING AND MUST BE CERTIFIED AS TO COMPLIANCE. THE INSTALLER OF THIS CRANE AND BODY IS CONSIDERED ONE OF THE MANUFACTURERS OF THE VEHICLE. AS SUCH A MANUFACTURER, THE INSTALLER IS RESPONSIBLE FOR COMPLIANCE WITH ALL APPLICABLE FEDERAL AND STATE REGULATIONS, AND IS REQUIRED TO CERTIFY THAT THE VEHICLE IS IN COMPLIANCE.

IT IS THE FURTHER RESPONSIBILITY OF THE INSTALLER OF THE CRANE TO COMPLY WITH THE OSHA TRUCK CRANE STABILITY REQUIREMENTS AS SPECIFIED BY 29 CFR PART 1910.180 (C) (1).

HC-5 NEXSTAR III GENERAL ASSEMBLY P/N: 361106521

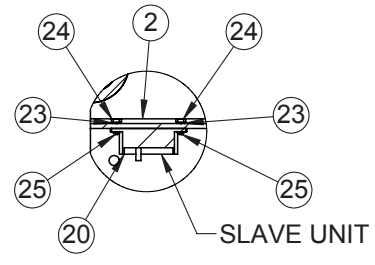
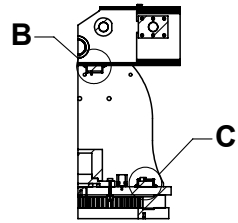
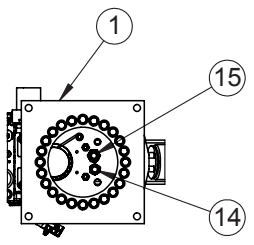
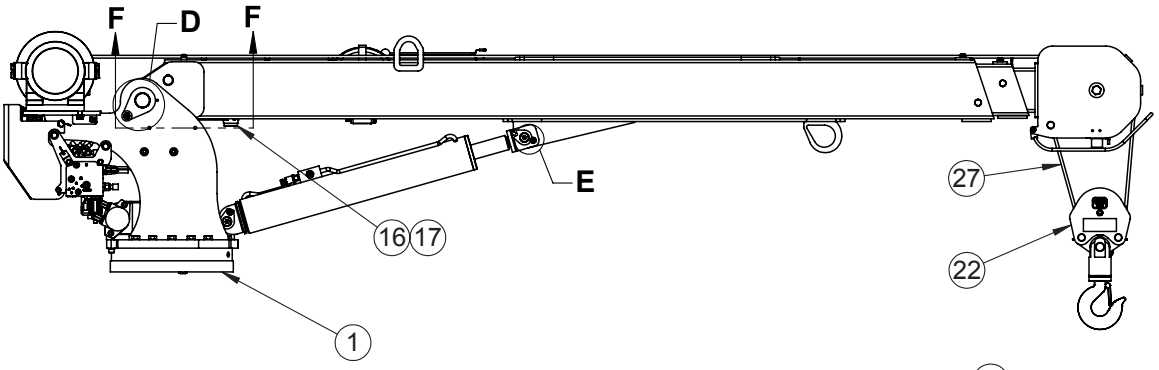
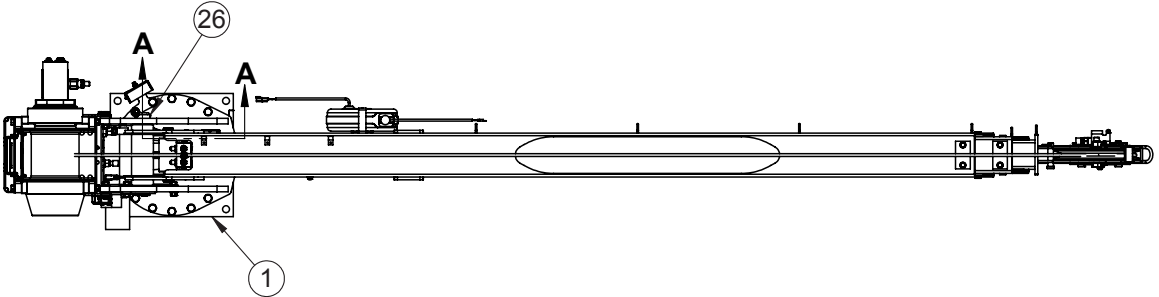

SECTION A-A

DETAIL B

NOTES:
1. APPLY LOCTIVE 242 TO THREADS BEFORE INSTALLATION

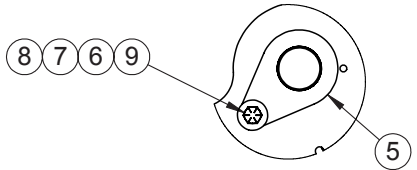
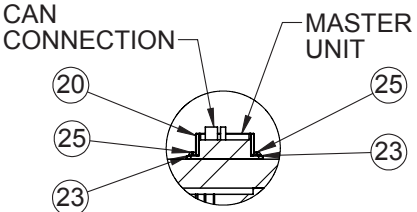

DETAIL C

DETAIL D

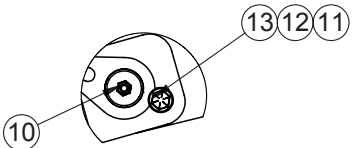

USE ZIP TIES TO TIE DOWN LED LIGHT WIRES

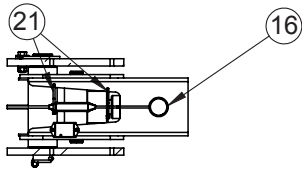

DETAIL E

SECTION F-F

HC-5 NEXSTAR III

GENERAL ASSEMBLY P/N: 361106521

ITEM NO.	QTY	PART NUMBER	DESCRIPTION
1	1	361106510	PEDESTAL ASS'Y, HC-5, FM, NEXSTAR III
2	1	360647010	BOOM ASSEMBLY, 5005EH, 5005H
1	1	361106524	SHIP KIT, HC-5, FM, NEXSTAR III
4	1	361106541	DECAL LAYOUT, HC-5, NEXSTAR
5	1	480988020	PIN, PIVOT, 8406H
6	1	021600	WASHER FL 1/2
7	1	021500000	WASHER, SP LK 1/2
8	1	017701	NUT HX 1/2-13UNC
9	1	738642000	SCREW HX HD 1/2-13UNC X 1 3/4 LG GR8
10	1	239300	ZERK, GREASE
11	1	320976000	WASHER, FLAT, 3/8 SAE HARDENED
12	1	021100	WASHER SP LK 3/8
13	1	366159000	SCREW HX HD 3/8-16UNC X 1 1/2 LG GR8
14	1	360445000	CAP, 8 JIC
15	1	367238	CAP, 10 JIC
16	1	366823236	LIGHT, LED (RED, GREEN, YELLOW)
17	1	002902000	SCREW SOC HD 1/4UNC X 1/2 GR8
18	1	480367	PIN BLOCK
19	1	360124	PIN HITCH
20	1	366823254	SENSOR, TRI-AXIS
21	2	772043000	ZIP TIE STRAP, 12 IN, NYLON, BLACK
22	1	360649000	TRAVELING BLOCK ASSY, LESS 2-BLOCK BAR, 5005H/EH
23	4	019700	WASHER SP LK #8
24	2	015500000	NUT HX #8-32UNC CP
25	4	001302000	SCREW RD HD #8-32UNC X 7/8 LG
26	1	360677000	PIN, 1/4 COTTERLESS RING
27	1	360758000	ROPE ASSY
28	1	330622	DECAL SERIAL NO
29	1	360676000	PIN, CYLINDER
30	1	360678000	PIN, 3/16 COTTERLESS RING

HC-5 NEXSTAR III PEDESTAL ASSEMBLY

P/N: 361106510

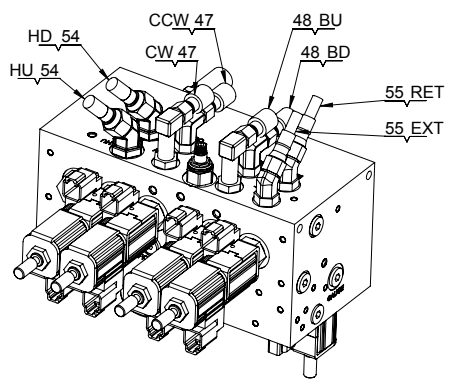
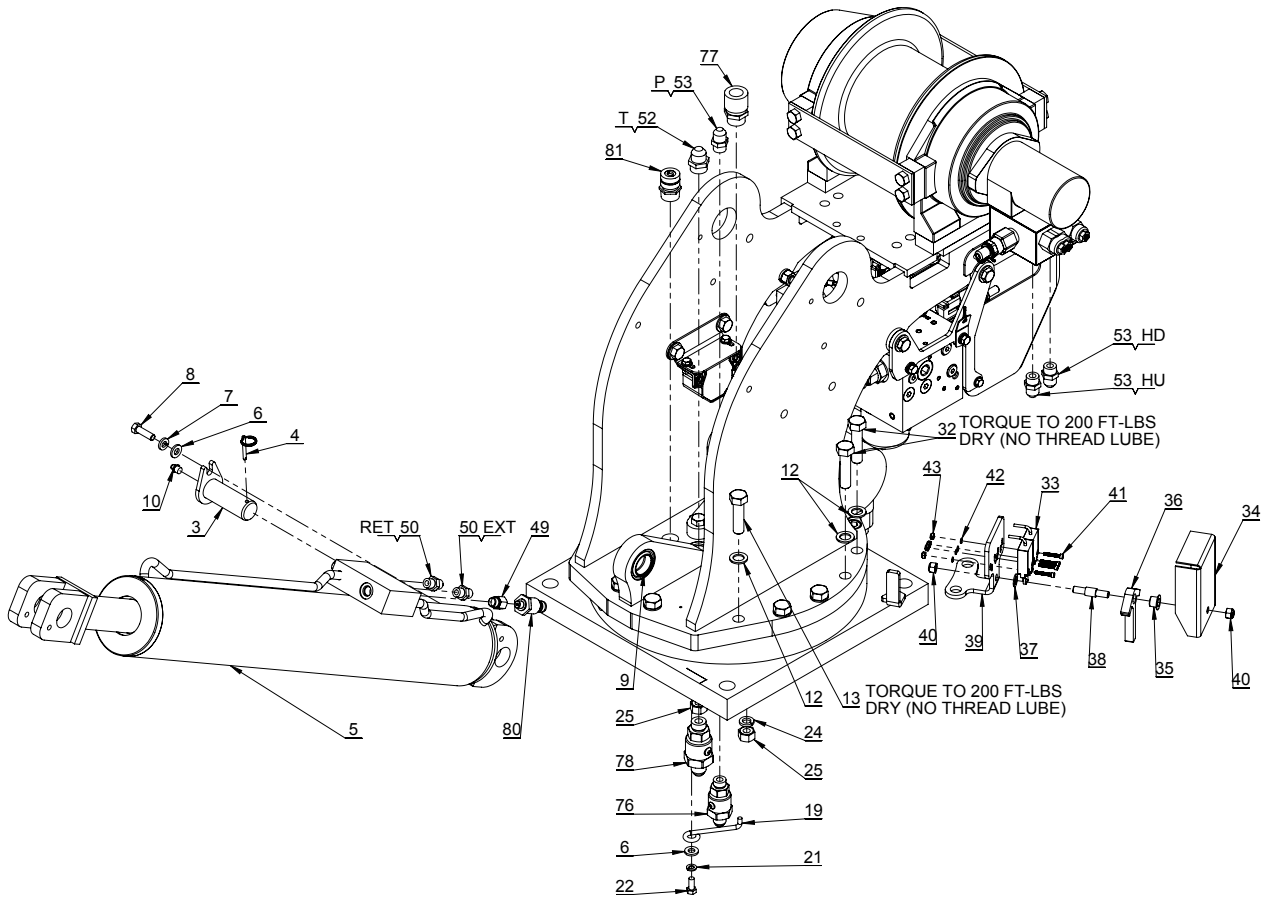

VALVE BANK HOISING DETAIL

HYDRAULICS:

- "HD" PORT: HOIST DOWN
- "HU" PORT: HOIST UP
- "CW" PORT: ROTATION CW
- "CCW" PORT: ROTATION CCW
- "BU" PORT: LIFT CYL EXTEND
- "BD" PORT: LIFT CYL RETRACT
- "EXT" PORT: EXT CYL EXTEND

"RET" PORT: EXT CYL RETRACT
 COUNTER BALANCE CARTRIDGE: 480188100

HC-5 NEXSTAR III PEDESTAL ASSEMBLY

P/N: 361106510

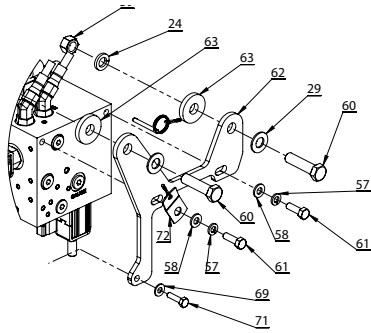

DETAIL A

TYPICAL BOTH SIDES OF VALVE BLOCK

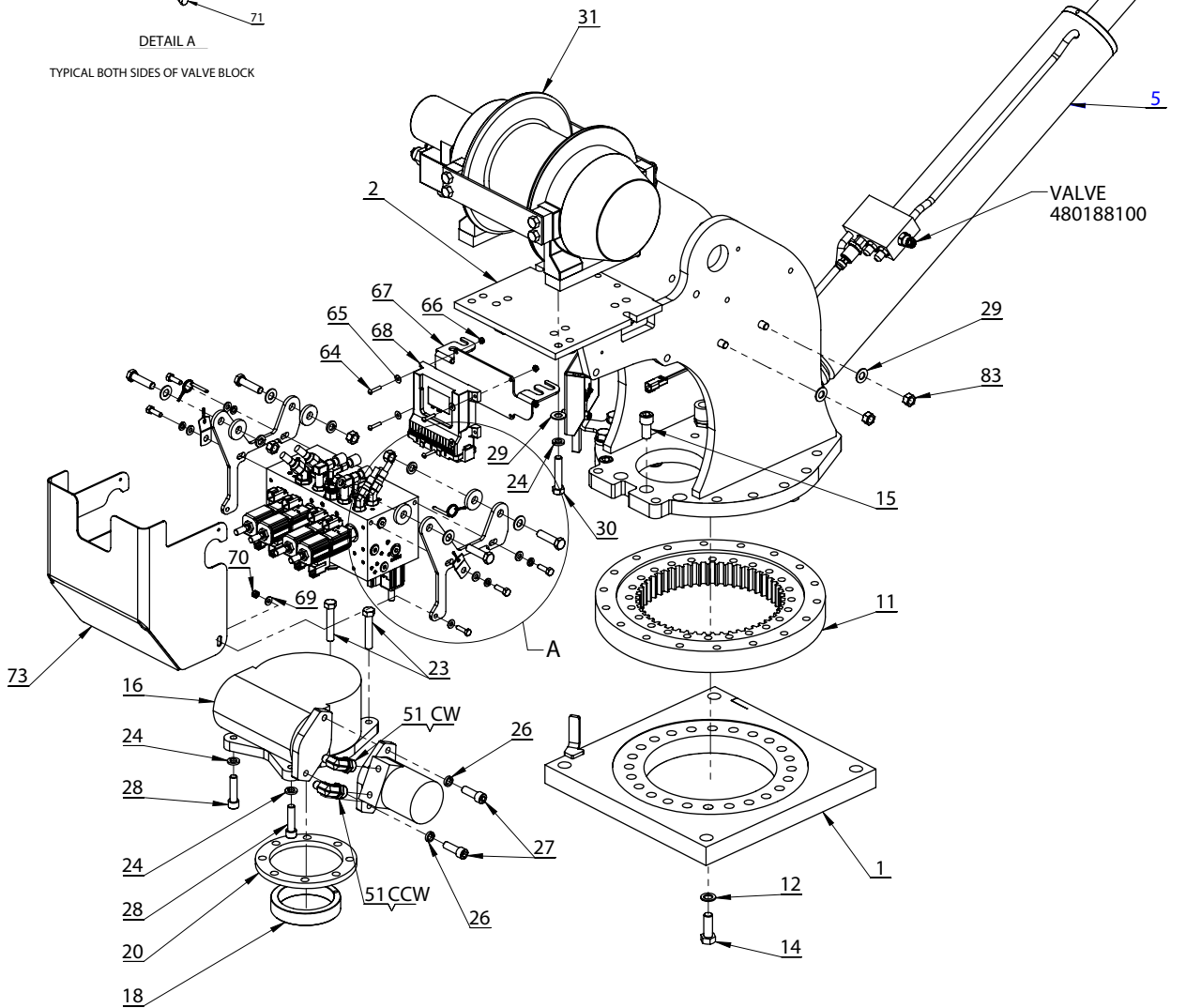

ADD 6 INCHES OF NYLON HOSE SLEEVE TO 812303023 WHERE IT RUBS AGAINST THE SIDE PLATE

ADD 6 INCHES OF NYLON HOSE SLEEVE TO 480205000 WHERE IT RUBS AGAINST THE VALVE BLOCK

HC-5 NEXSTAR III PEDESTAL ASSEMBLY

P/N: 361106510

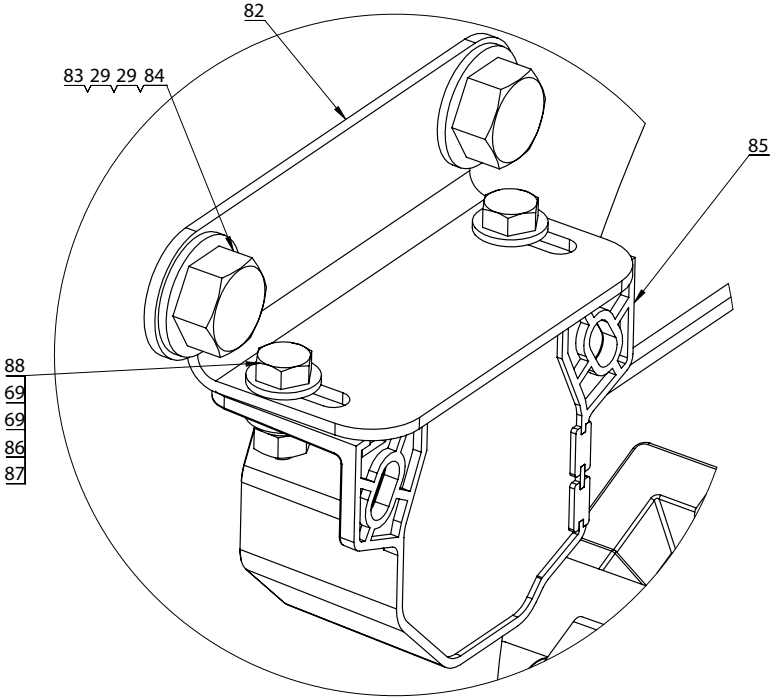
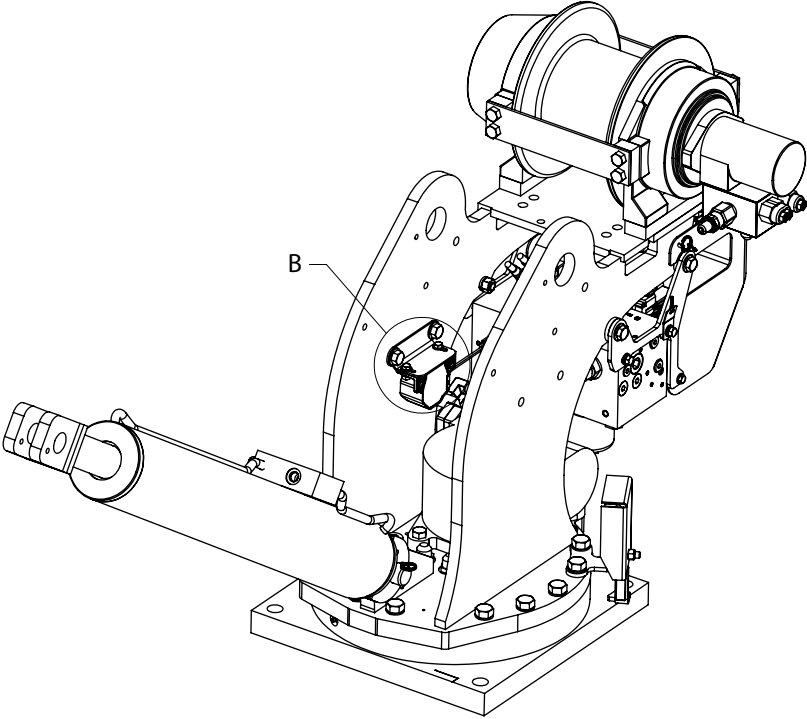

DETAIL B

HC-5 NEXSTAR III PEDESTAL ASSEMBLY

P/N: 361106510

ITEM NO.	QTY	PART NUMBER	DESCRIPTION
1	1	480988220	BASE PLATE WELDMENT
2	1	480988210	PEDESTAL WELD, LARGE CRANE
3	1	360676000	PIN, CYLINDER
4	1	360678000	PIN, 3/16 COTTERLESS RING
5	1	366822255	CYLINDER, LIFT, 5005EH, STROKE - 27.81
6	2	320976000	WASHER, FLAT, 3/8 SAE HARDENED
7	1	021100000	WASHER SP LK 3/8
8	1	366159000	SCREW HX HD 3/8-16UNC X 1 1/2 LG GR8
9	1	366333000	BEARING, SPHERICAL 1.25 ID
10	1	239300000	ZERK, GREASE
11	1	480023002	BEARING ROTATION 5005-8005
12	36	023902000	WASHER FL 5/8 HARDENED
13	10	490171000	SCREW HX HD 5/8-11UNC X 2 1/4 LG GR8
14	24	012198000	SCREW HX HD 5/8-11UNC X 1 3/4 LG GR8
15	4	006205000	SCREW SOC HD 5/8-11UNC X 1 1/4 LG
16	1	160407	GEAR BOX, ROTATION
17	1	366440000	ROTATION MOTOR
18	1	360162000	RING, ECCENTRIC
19	1	360207000	RETAINER ECCENTRIC RING
20	1	480011000	SEAL ROTATION BOX
21	1	020601000	WASHER SP LK 5/16
22	1	007807000	SCREW HX HD 5/16-18UNC X 3/4 LG GR5
23	2	011202000	SCREW HX HD 1/2-20UNF X 2 3/4 LG GR5
24	16	021500000	WASHER, SP LK 1/2
25	2	017704000	NUT HX HVY 1/2-20UNF
26	2	021502000	WASHER SP LK 1/2 HI COLLAR
27	2	012197000	SCREW SOC HD 1/2-13UNC X 1/2 LG
28	2	009118000	SCREW SOC HD 1/2-13UNC X 2 LG
29	16	320588000	WASHER, FL 1/2, HARDENED
30	8	011609000	SCREW 1/2 X 2 1/2NC GR5
31	1	123339	WINCH- RPH 2500 W/ RELIEF VALVE
32	2	366393000	SCREW HX HD 5/8-11UNC X 2 1/2 LG GR8
33	1	460110100	ROTATION STOP SWITCH ASSEMBLY, 24"
34	1	366676000	COVER, ROTATION STOP
35	1	460079000	BEARING, ROTATION STOP

HC-5 NEXSTAR III PEDESTAL ASSEMBLY

P/N: 361106510

ITEM NO.	QTY	PART NUMBER	DESCRIPTION
36	1	366671000	ARM, ROTATION STOP
37	1	366675000	WASHER, NYLON
38	1	366673000	PIN, ROTATION STOP
39	1	480988255	BRACKET, ROT STOP
40	2	017301000	NUT HX NYLK 3/8-16UNC CP
41	4	006210000	CAPSCREW-#8-32 X 7/8 LG SOC HD Z/P
42	4	019700000	WASHER SP LK #8
43	4	725321000	NUT HX NYLK #8-32UNC
44	1	813013000	KIT, HOSE 5005H-6406H FULLY PROP
*45	1	480201000	HOSE ASSY 8 STR X 21.5
*46	1	812403022	HOSE ASSY 10 JIC STR
*47	2	812203037	HOSE ASSY 6 JIC STR
*48	2	480205000	HOSE ASSY 6 STR X 19.25
*49	1	369611000	ADAPTER, STR -6 ORM/ -4 ORF
*50	2	200876000	FITTING 6 SAE/6 JIC STRAIGHT
*51	2	490198000	FITTING 10SAE(M)/6JIC ELBOW 90
*52	1	490199000	FITTING STR 10-SAE/10-JIC
*53	3	770055000	FITTING 8 SAE/8 JIC STRAIGHT
*54	2	812303023	HOSE ASSY 8 JIC STR
*55	2	812203022	HOSE ASSY, -6 JIC FEM, STR
*56	47"	374086000	NYLON HOSE SLEEVE, 1.81" ID
57	4	020600000	WASHER 5/16 LOCK SS
58	4	020901000	WASHER FL 5/16
59	4	017701000	NUT HX 1/2-13UNC
60	4	011608000	SCREW HX HD 1/2UNC X 2 GR5
61	4	007811000	SCREW HX HD 5/16-18UNC X 1 LG GR5
62	2	366823210	BRACKET, VALVE MTG
63	4	366823211	SPACER, VALVE BANK
64	4	460093000	SCREW RD HD SL #10-24UNC X 1 LG ZP
65	4	020000000	WASHER FL #10 ZP
66	4	015801000	NUT HX NYLK #10-24UNC ZP
67	1	366823212	BRACKET, RECEIVER MTG

HC-5 NEXSTAR III PEDESTAL ASSEMBLY

P/N: 361106510

ITEM NO.	QTY	PART NUMBER	DESCRIPTION
**68	1	366823963	TRANSCEIVER, NEXSTAR III
69	8	020400000	WASHER FL SAE 1/4
70	2	016300000	NUT HX NYLK 1/4-20UNC
71	2	005604000	SCREW HX HD 1/4-20UNC X 1 LG
72	2	366823240	PIN, 3/16 W/LANYARD
73	1	366823025	COVER, VALVE, REAR MTD FM
74	1	366823271	KIT, ELEC/HYD NEXSTAR III, 8 GPM AND BELOW
**75	1	366823251	VALVE BANK, 8 GPM W/FILTER SENSOR
76	1	366359000	FITTING, -8 SAE / -8 JIC, SWIVEL, STR
77	1	366508000	CORD GRIP HUBBLE F-3 SHC 1036
78	1	366358000	FITTING, -10 SAE / -10 JIC, SWIVEL, STR
79	1	361106511	TAG, ID HC-5
**80	1	366823255	TRANSDUCER, PRESSURE 0-3000 PSI
81	1	366698000	CORD GRIP .375-.500 3/4" HUB
82	1	366823224	BRACKET, ALARM, HC-6 TO HC-9
83	2	738058008	NUT HX 1/2-13UNC
84	2	010201000	SCREW HX HD 1/2-13UNC x 1 1/2 LG
85	1	366823223	KIT, ALARM, CONSTANT TONE, W/ DEUTSCH PLUG
86	2	020200000	WASHER SP LK 1/4
87	2	015900000	NUT HX 1/4-20UNC SS
88	2	005500000	SCREW HX HD 1/4-20UNC X 3/4 LG
89	1	366823220	HARNESS, NEXSTAR III, HYD. CRANES

NOTE: *PARTS INCLUDED IN HOSE KIT

**** PARTS INCLUDED IN ELECTRICAL KIT**

HC-5 NEXSTAR III BOOM ASSEMBLY P/N: 360647010

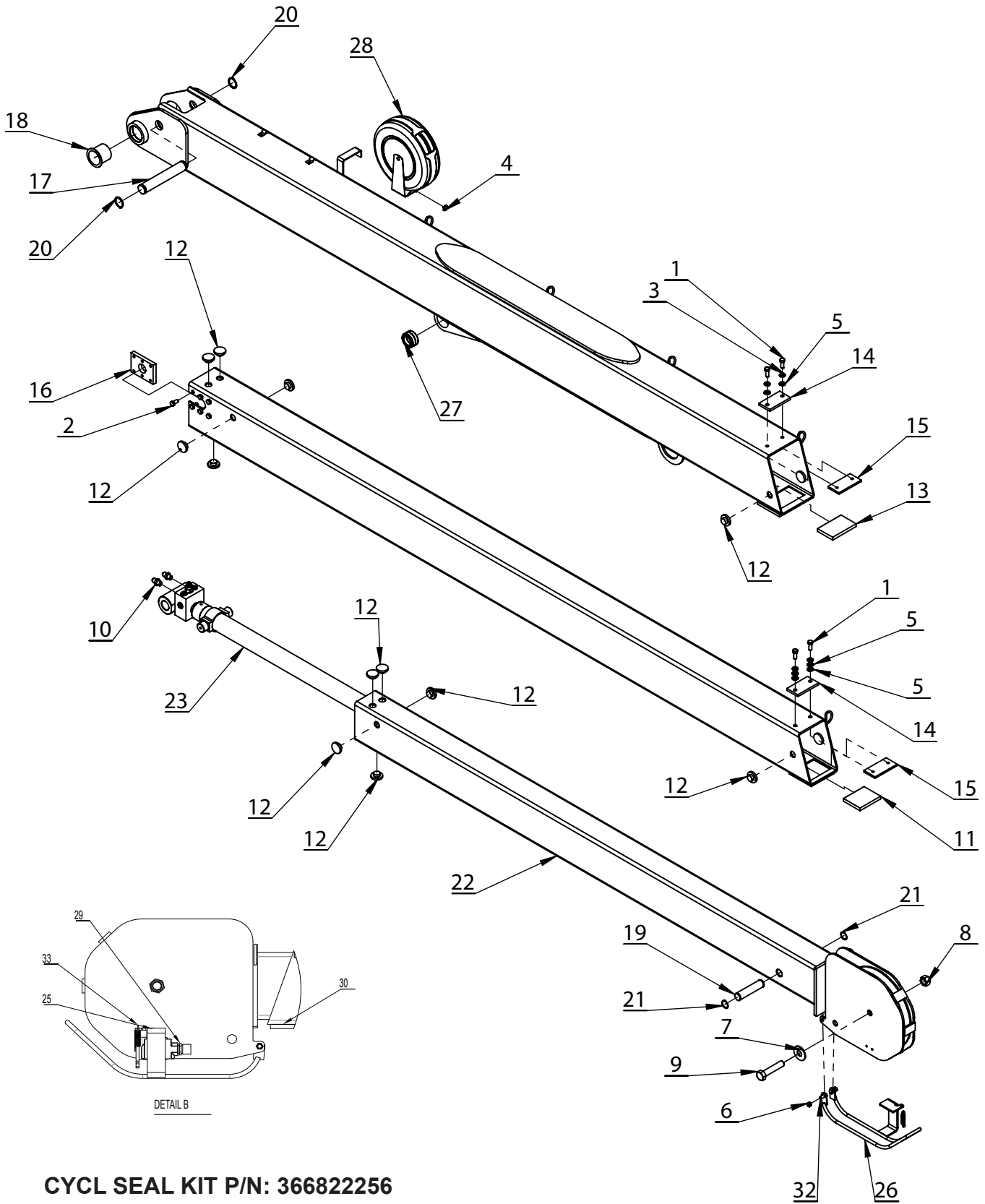

CYCL SEAL KIT P/N: 366822256
C'BAL P/N: 360153001

HC-5 NEXSTAR III BOOM ASSEMBLY

P/N: 360647010

ITEM NO.	QTY	PART NUMBER	DESCRIPTION
1	4	008800000	SCREW HX HD 3/8-24UNF X 1 LG
2	12	008400000	SCREW HX HD 3/8-16UNC X 3/4 LG GR 5
3	4	021100000	WASHER SP LK 3/8
4	1	360882000	NUT, PUSH-ON TYPE (.161-.164DIA)
5	6	021200000	WASHER FL 3/8
6	2	016801000	NUT HX NYLK 5/16-18UNC CP
7	1	022102000	WASHER FL 3/4
8	1	360756000	NUT, HX NYLK 3/4-10UNC
9	1	367366000	SCREW HX HD 3/4-10UNC X 3-1/2 LG
10	2	200876000	FITTING 6 SAE/6 JIC STRAIGHT
11	1	360674000	WEAR PAD, BOTTOM UPPER
12	14	360767000	PAD BOOM 1.5 O.D.
13	1	460053000	WEAR PAD, BOTTOM UPPER
14	2	366201000	WEAR PAD 3 .75 X 2.00 X .313
15	2	366483000	PLATE, WEAR PAD .25 X 2 X 4
16	2	366184000	RETAINER, EXTENSION CYLINDER
17	1	366193000	PIN 1 X 7.66 LG
18	2	366394000	BEARING, PIVOT
19	1	738732000	PIN 1 X 4.063 LG
20	2	480029000	RING RETAINING
21	2	360122000	RING RETAINING 5100-98
22	1	360666010	UPPER BOOM WELDMENT, 5005EH, 5005H
23	1	360789000	CYL EXTENSION DUAL
24	1	366198000	SHEAVE ASSY 3/8
25	1	646900000	SWITCH, LIMIT ANTI-TWO BLOCK
26	1	470110160	BAIL WELDMENT W/ 2 IN TRIP BAR
27	1	366333000	BEARING, SPHERICAL 1.25 ID
28	1	360759001	CORD REEL ASSY
29	1	642918000	CORD CONNECTOR
30	1	360665010	MID BOOM WELMENT, 5005EH, 5005H
31	1	361106115	LOWER BOOM WELDMENT 5005EH, 5005H
32	2	007807000	SCREW HX HD 5/16-18UNC X 3/4 LG GR5
33	1	366678000	SPRING, EXTENSION

HC-5 NEXSTAR III ROTATION GEARBOX

P/N: 160407

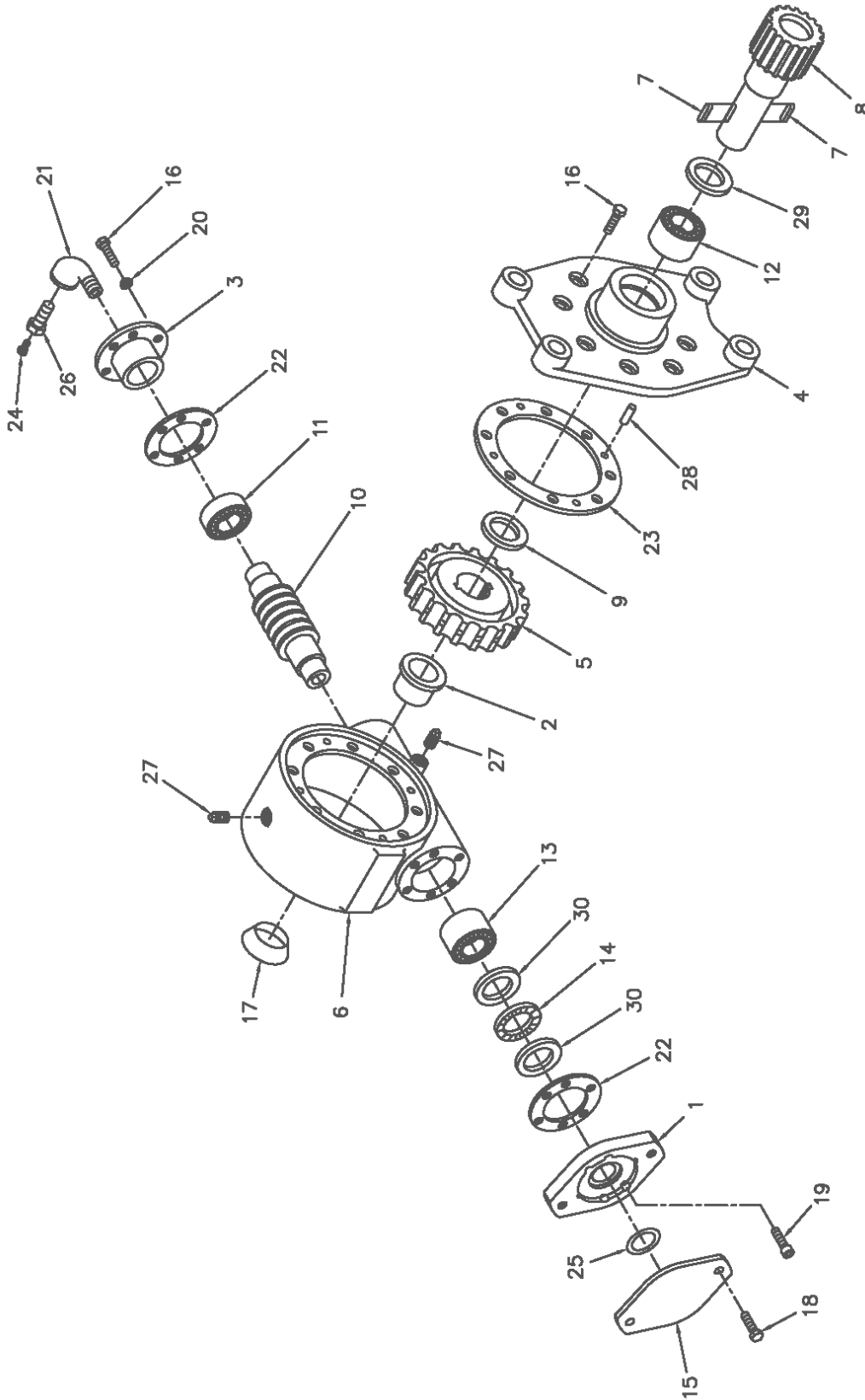

HC-5 NEXSTAR III ROTATION GEARBOX

P/N: 160407

ITEM NO.	QTY.	PART NO.	DESCRIPTION
1	1	300058	ADAPTER
2	1	308085	BUSHING
3	1	316092	CAP BEARING
4	1	328126	COVER
5	1	334016	GEAR R.H.
6	1	338261	HOUSING GEAR
7	2	342120	KEY
8	1	357139	SHAFT OUTPUT
9	1	366019	WASHER THRUST
10	1	368183	WORM R.H.
11	1	402044	BEARING BALL
12	1	402105	BEARING NEEDLE
13	1	402106	BEARING NEEDLE
14	1	402107	BEARING THRUST
15	1	413013	COVER
16	14	414146	SCREW HX HD 5/16 NC X 1-1/4 GR5 (NYLON HEAVY PATCH)
17	2	414581	SCREW HX HD 1/2 NC X 3/4 GR5
18	6	414869	SCREW SOC HD 5/16 NC X 1
19	6	418163	WASHER LK 5/16 MED SECT
21	2	442182	GASKET
22	1	442187	GASKET
23	1	456008	FITTING RELIEF
24	1	462029	O-RING
26	2	468018	PLUG PIPE
27	4	470062	PIN DOWEL
28	1	486071	SEAL OIL
29	2	518026	WASHER THRUST
30	1	472088	PLUG - EXPANSION

HC-5 NEXSTAR III HOIST ASSEMBLY

P/N: 123339

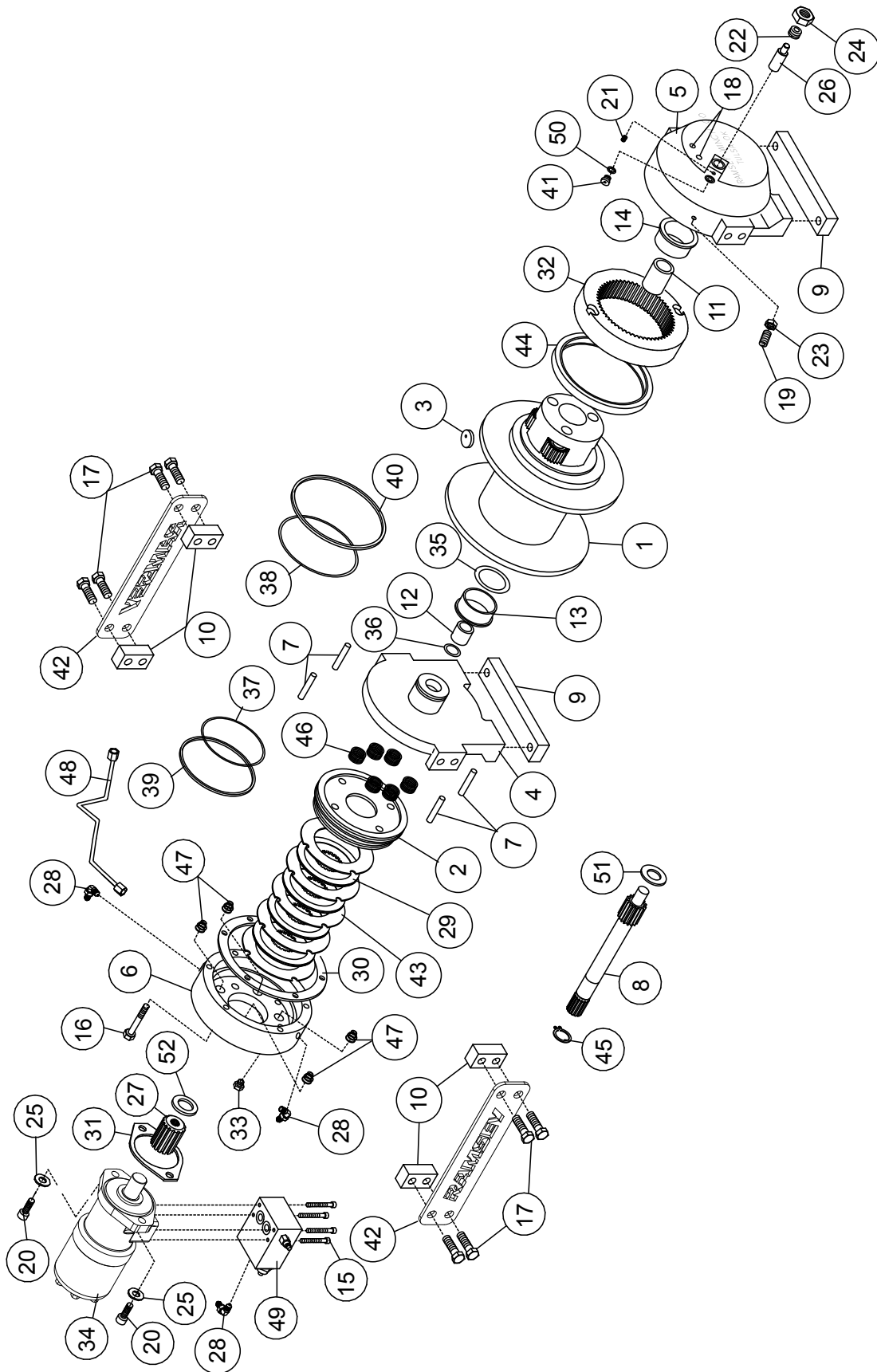

HC-5 NEXSTAR III HOIST ASSEMBLY

P/N: 123339

Item	Quantity	Part No.	Description
1	1	234189	DRUM ASSEMBLY
2	1	306042	PISTON-BRAKE
3	1	315004	ANCHOR- CABLE
4	1	338300	END BRG-MOTOR END
5	1	338301	END BRG-GEAR HSG.
6	1	338302	HSG-BRAKE
7	4	346045	PIN-BRAKE
8	1	357513	SHAFT- INPUT
9	2	362291	SPACER - FOOT MOUNTING
10	4	362284	SPACER - TIE PLATE
11	1	402120	BEARING
12	1	402121	BEARING
13	1	412084	BUSHING-DRUM,MOTOR END
14	1	412085	BUSHING-DRUM,GEAR END
15	4	414129	CAPSCREW 5/16-18NCX3 LG HX
16	6	414303	BOLT-3/8-16NC X2 1/2,HXHD,GR-5
17	8	414548	CAPSCREW-1/2-13NCX1 1/2,HXHD
18	2	414854	SCREW-1/4-20NCX1/2LG,RDHD
19	1	414926	SETSCREW-3/8-16NC X1,SCKT,NYL
20	2	414948	CAPSCREW-1/2-13NCX1 1/4LG,SCKET
21	1	416016	SETSCREW1/4-20NCX1/4 HX SOCK HD
22	1	416080	SETSCREW-5/8-18NF X1 LG,HXSOCHD
23	1	418036	NUT-3/8-16 NC,HEX JAM,Z/P
24	1	418088	NUT-JAM 5/8-18NF HEX HD,ZINC PLT
25	2	418218	LOCKWASHER-1/2 ID MED SECT,ZC PLT
26	1	426048	PLUNGER-CLUTCH,BLOCKED
27	1	431015	COUPLING-MOTOR
28	2	432018	FITTING
29	4	438022	DISC-BRAKE
30	1	442220	GASKET-BRAKE HSG.

HC-5 NEXSTAR III HOIST ASSEMBLY

P/N: 123339

Item	Quantity	Part No.	Description
31	1	442223	GASKET-MOTOR FLANGE
32	1	444085	GEAR-RING,P/M
33	1	456038	FITTING-VENT,BREATHER
34	1	458124	MOTOR-HYDRAULIC
35	1	462046	O-RING
36	1	462056	O-RING
37	1	462057	O-RING
38	1	462058	O-RING
39	1	462059	O-RING-BACK-UP
40	1	462060	O-RING-BACK-UP
41	1	472052	PLUG
42	2	395426	TIE PLATE
43	5	474111	PLATE-SEPARATOR, BRAKE
44	1	486080	SEAL
45	1	490037	SNAP RING
46	6	494110	SPRING-BRAKE
47	4	494112	SPRING
48	1	509126	TUBE ASSY
49	1	516069	VALVE-MOTOR CONTROL
50	1	518037	THRUST WASHER
51	1	518047	THRUST WASHER
52	1	518052	THRUST WASHER

HC-5 NEXSTAR III TRAVELING BLOCK ASSEMBLY P/N: 360649000

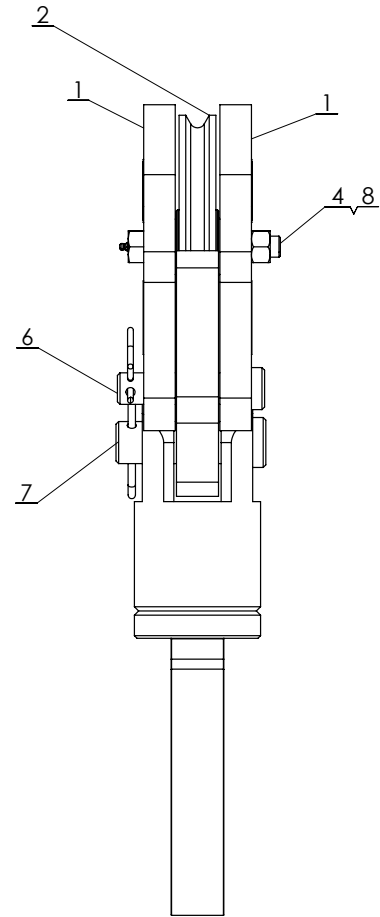
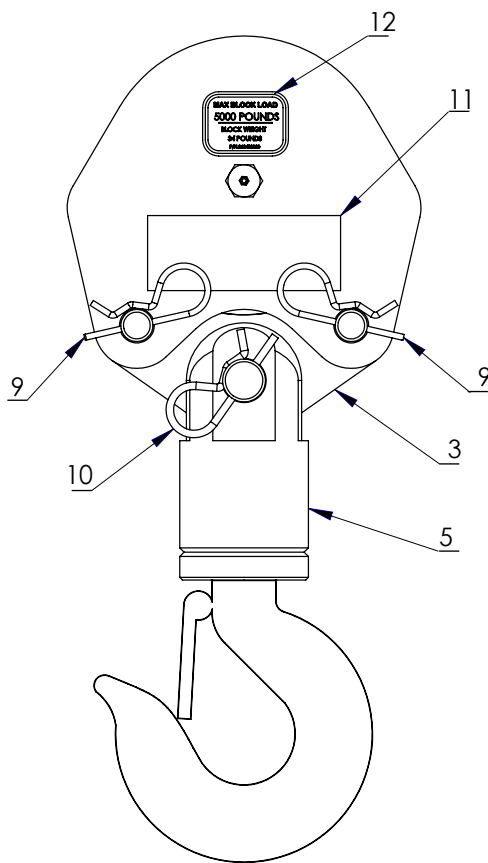

ITEM NO.	QTY	PART NO.	DESCRIPTION
1	2	480363000	SHORT BLOCK SIDE PLATE
2	1	480130000	SHEAVE ASSY
3	1	480364000	TACKLE FLOWER
4	1	480372000	BOLT, SHEAVE W/ ZERK FITTING
5	1	480371000	HOOK SWIVEL 3 METRIC TON
6	2	480367000	PIN BLOCK
7	1	480368000	PIN SWIVEL HOOK
8	1	017800000	NUT, HX LK 1/2-20UNF
9	2	366183000	PIN HITCH
10	1	360124000	PIN HITCH
11	2	040518000	DECAL STAY CLEAR OF LOAD
12	2	360480100	DECAL, MAX LOAD BLOCK

HC-5 NEXSTAR III MAIN HARNESS

P/N: 366823220

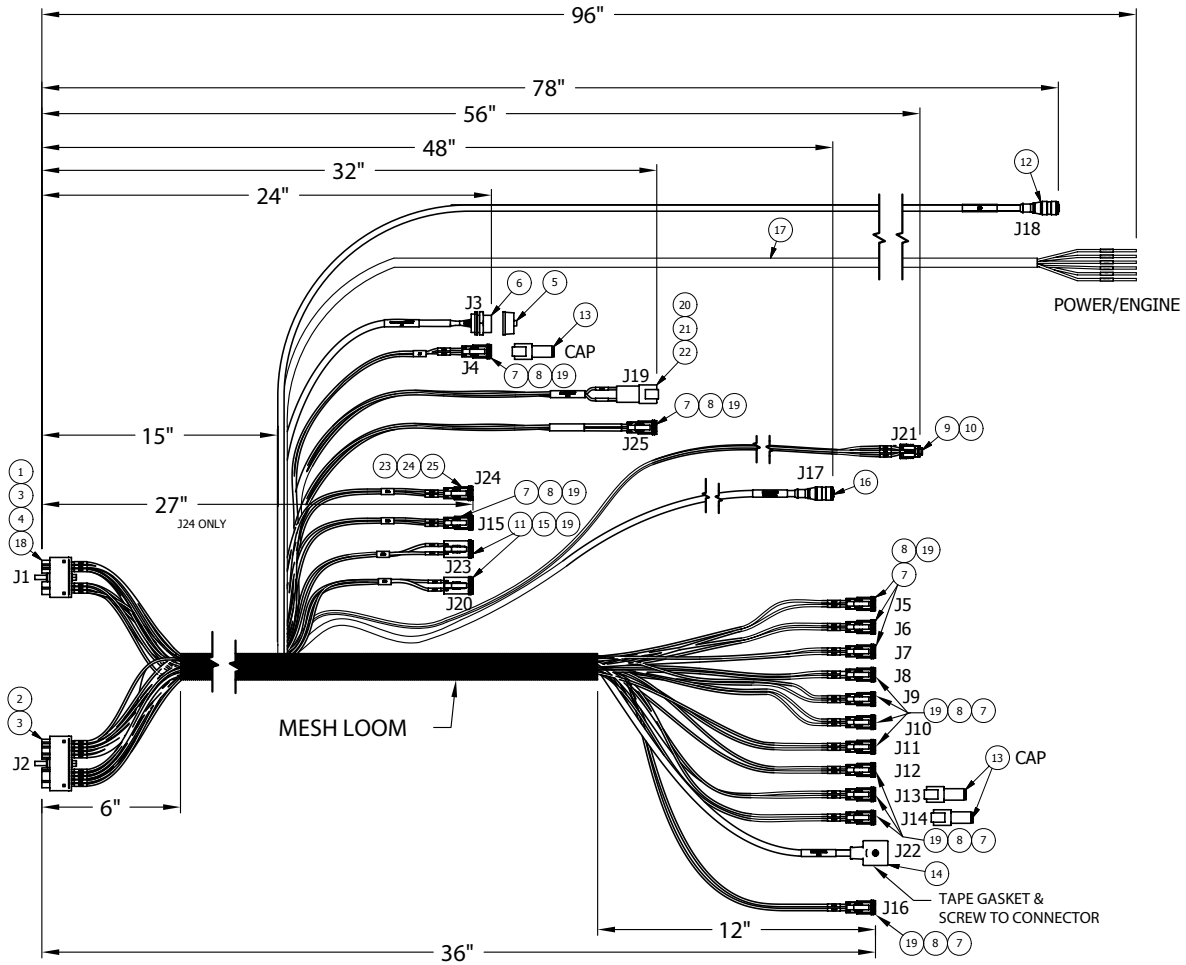

NOTE: REFERENCE ELEC. SCHEMATIC 366823221 FOR PIN OUT INFORMATION

CONNECTOR ID	
CONNECTOR	DESCRIPTION
J1	RECIEVER 18 PIN CONNECTION
J2	RECIEVER 30 PIN CONNECTION
J3	USB CONNECTION
J4	CAN CONNECTOR
J5	BOOM UP
J6	BOOM DOWN
J7	SWING CW
J8	SWING CCW
J9	BOOM RETRACT
J10	BOOM EXTEND
J11	HOIST A DOWN
J12	HOIST A UP
J13	HOIST B DOWN
J14	HOIST B UP
J15	ANTI-2 BLOCK
J16	DUMP VALVE
J17	BOOM ANGLE SENSOR
J18	PENDANT CONNECTION
J19	ALARM LIGHT
J20	ADDRESS
J21	BOOM PT
J22	DIRTY FILTER
J23	SWING LIMIT SWITCHES
J24	AUXILIARY
J25	HORN

HC-5 NEXSTAR III MAIN HARNESS

P/N: 366823221

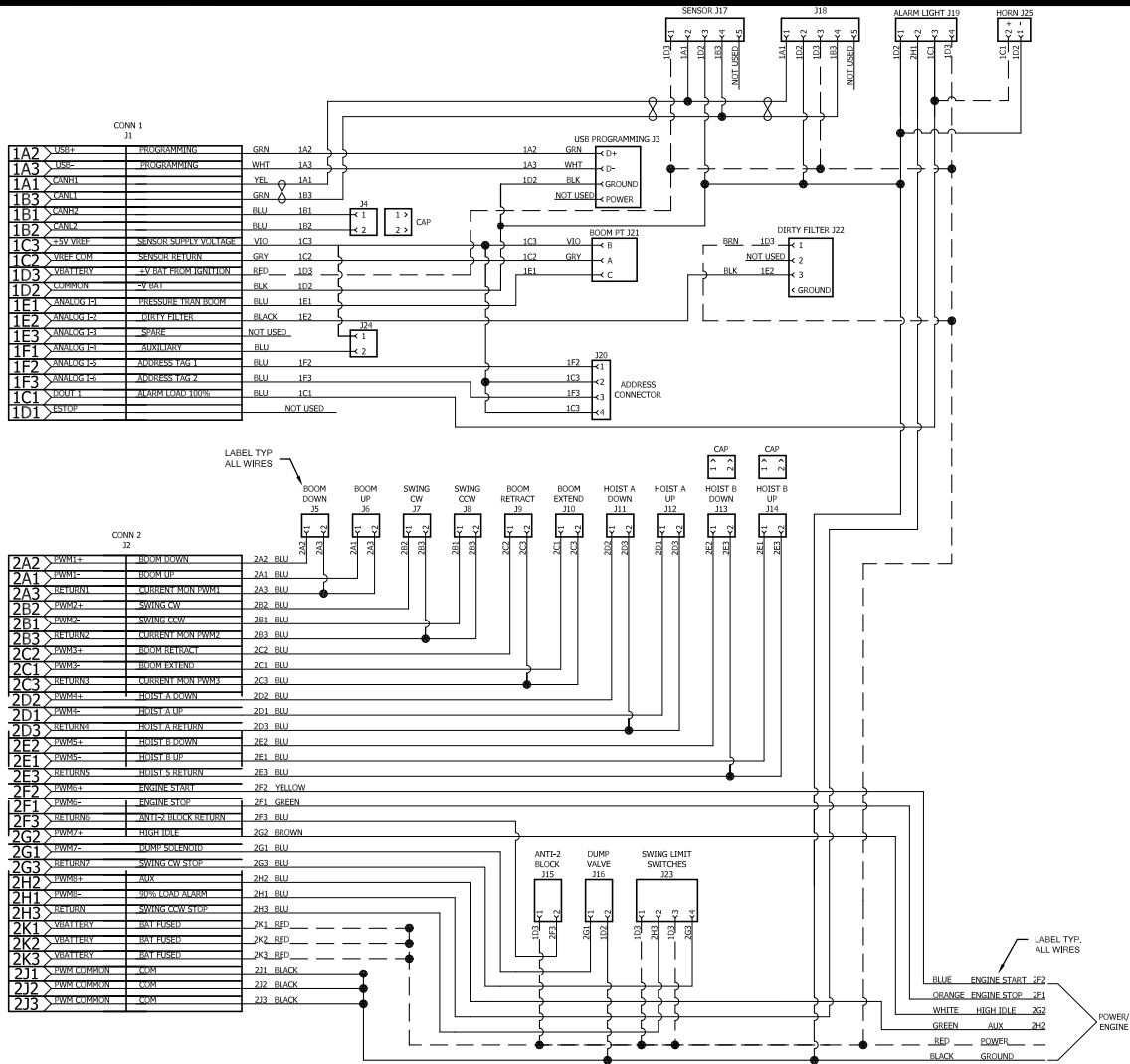

WIRING DETAIL	
CONNECTOR	FUNCTION
J3	USB CONNECTION
J4	CAN CONNECTION
J5	BOOM UP
J6	BOOM DOWN
J7	SWING CW
J8	SWING CCW
J9	BOOM RETRACT
J10	BOOM EXTEND
J11	HOIST A DOWN
J12	HOIST A UP
J13	HOIST B DOWN
J14	HOIST B UP
J15	ANTI-2 BLOCK
J16	DUMP VALVE
J17	BOOM ANGLE SENSOR
J18	PENDANT CONNECTION
J19	ALARM LIGHT
J20	ADDRESS
J21	BOOM PT
J22	DIRTY FILTER
J23	SWING LIMIT SWITCHES
J24	AUXILIARY
J25	HORN
PWR/ENG	POWER/ENGINE

HC-5 NEXSTAR III HYDRAULIC CONTROL VALVE P/N: 366823251

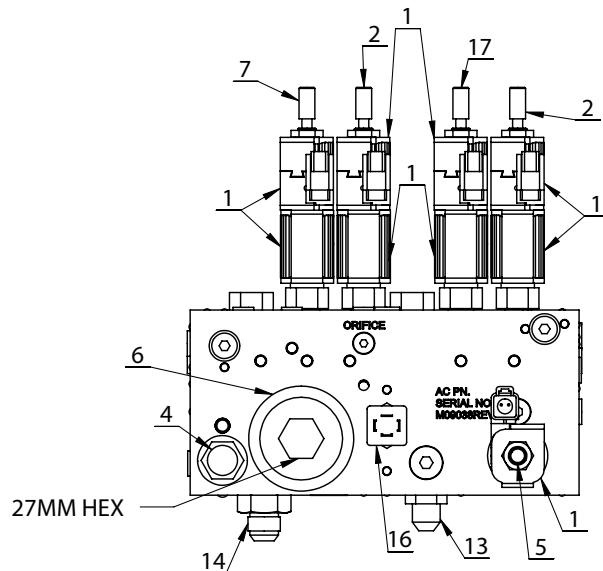
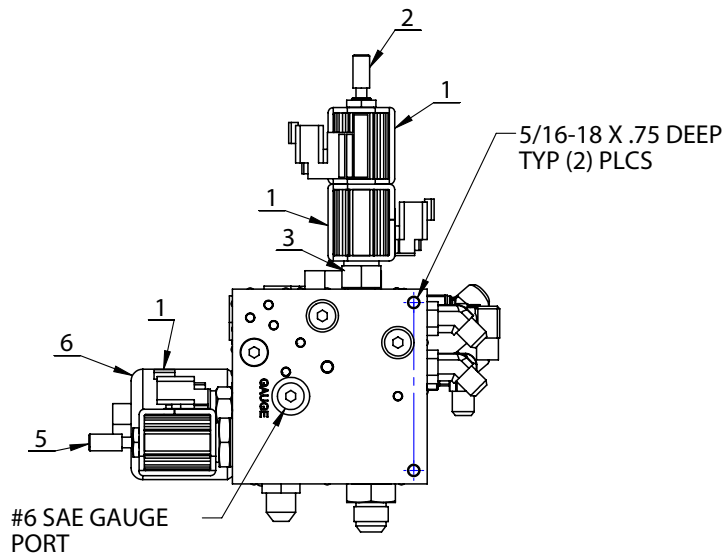
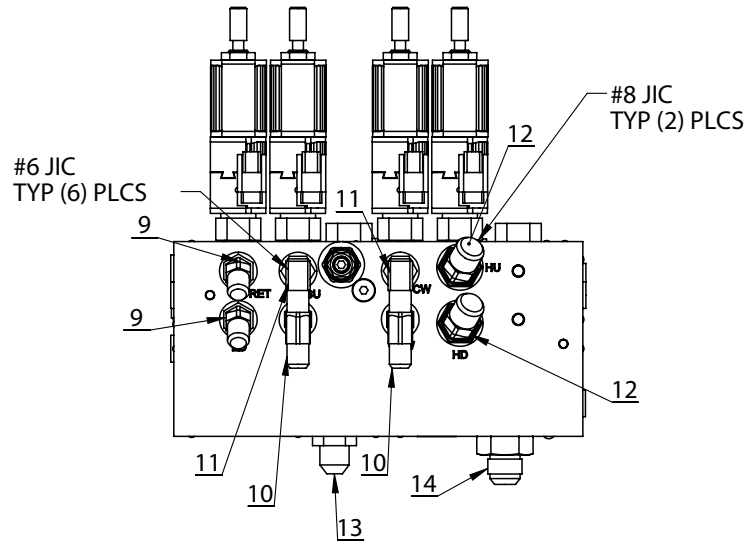

HC-5 NEXSTAR III HYDRAULIC CONTROL VALVE P/N: 366823251

ITEM NO.	QTY	PART NUMBER	DESCRIPTION
1	9	366823901	COIL, 5/8" DIA 12VDC DEUTSCH
2	2	366823902	CARTRIDGE, SIZE 4W 3P CLSD CTR
3	2	366823906	VALVE, LOGIC SPOOL TYPE 290 PSI
4	1	366823914	VALVE, CHECK 100 PSI
5	1	366823904	CARTRIDGE, 2-WAY UNLOADER
6	1	366823909	BOWL, FILTER
7	1	366823903	CARTRIDGE, SIZE 4W 3P FLOAT CTR
8	1	366823905	VALVE, RELIEF DIRECT-ACTING (2750PSI)
9	2	480195000	FITTING 45 6-SAE/6-JIC
10	2	241175000	FITTING 90 6-SAE/6-JIC
11	2	330645000	FITTING 90 6-SAE/6-JIC LONG
12	2	374017000	FITTING 45 8-SAE/8-JIC
13	1	372041000	FITTING 8JIC/10SAE STRAIGHT 8-10 F50X
14	1	372260000	FITTING, 10-12 JIC/SAE STR
15	1	366823910	FILTER, 20 MICRON
16	1	366823913	INDICATOR, CLOGGING FILTER 101.5 PSI
17	1	366823911	CARTRIDGE, SIZE 4W 3P FLOAT CTR - 6GPM

HC-5 NEXSTAR III

COUNTER VALVE ADJUSTMENT

Counterbalance Valve Adjustment

1. With PTO disengaged and boom properly supported, remove the plug on the counterbalance valve. Install a pressure gauge (0-3000 PSI) into the port.
2. Engage PTO and insure pump flow is 8 to 9 GPM. With no load on boom, boom up to an angle of 70 degrees. Boom down and note pressure. If pressure reading is not approximately 1300 PSI, the counterbalance valve requires adjustment.
 - A. To increase the CB valve setting, loosen nut and turn Allen head screw counter clockwise.
 - B. To reduce the CB valve setting, loosen nut and turn Allen head screw clockwise.
3. Tighten nut on adjustment screw and repeat procedure if needed to obtain the proper pressure setting.
4. Disengage PTO, remove the pressure gauge and install plug. Crane is now ready for operation.

Notice:

1. In an EMERGENCY situation when it becomes necessary to lower the boom without flow present, the CB valve adjustment can be turned in until the boom begins to descend. Make sure the boom will lower onto a proper support. Loosen the lock nut and carefully turn adjustment screw clockwise! Count the number of turns. Turn slowly until the boom just begins to lower, and remove hand/arm/fingers from cranes while boom is lowering.
2. Turning adjustment screw too far will cause valve to come apart on the inside. This condition is not repairable
3. After boom is lowered, turn adjustment screw counter clockwise the approximate number of turns made during lowering procedure. After the problem is corrected, readjust the counterbalance valve using the procedure in this manual.

WARNING:

**DO NOT TRY TO ADJUST VALVES WHILE BOOM IS MOVING.
Doing so may result in injury!**

HC-5 NEXSTAR III VALVE OVERRIDE OPERATION

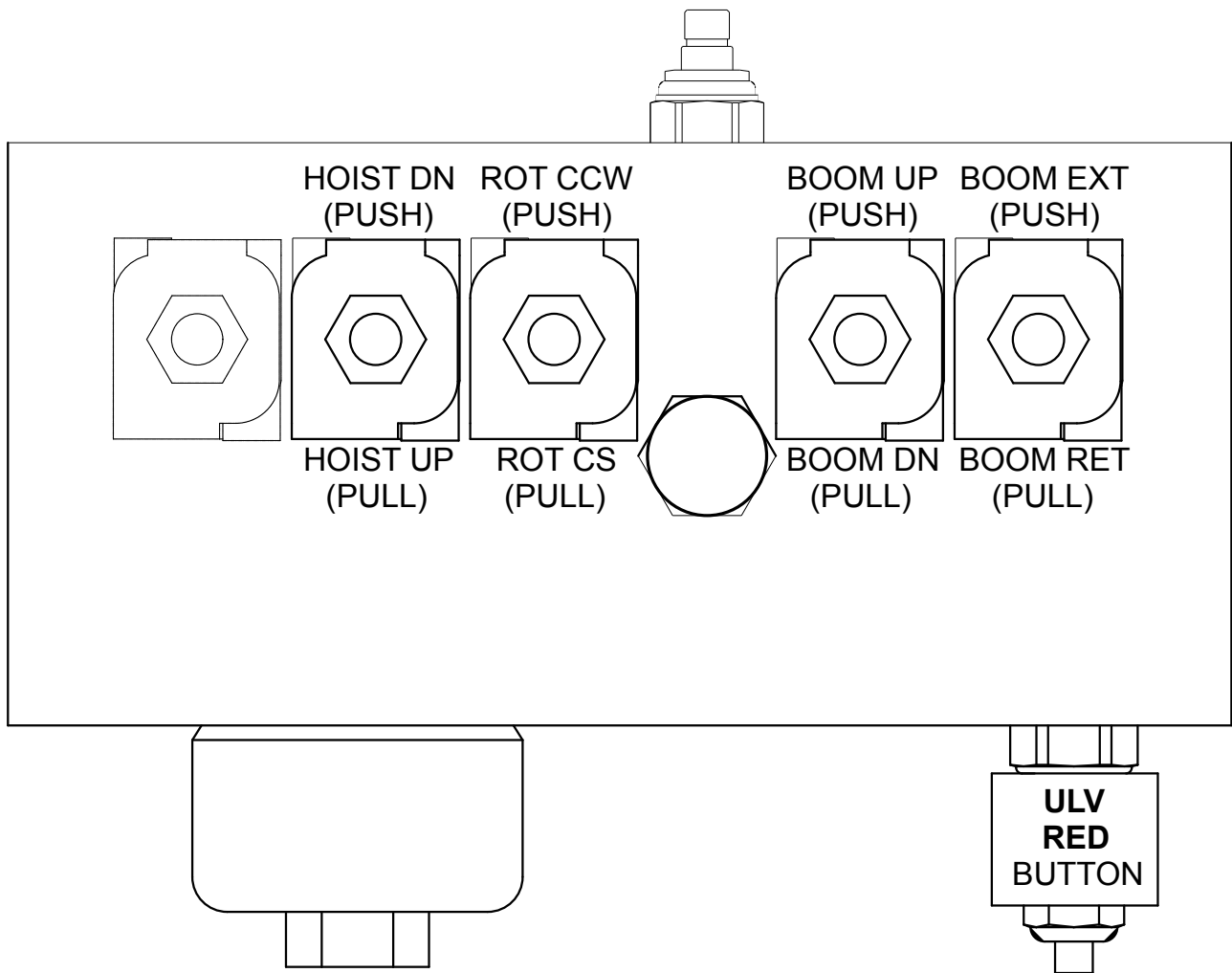

MANUAL OVERRIDE PROCEDURES

- 1) PUSH IN THE UNLOADER VALVE (ULV) RED BUTTON. THIS WILL SEND HYDRAULIC FLUID TO THE VALVE BLOCK.
- 2) SELECT THE FUNCTION DESIRED, THEN CLOSE THE GAP BETWEEN COLLAR AND THE END ON THE OVERRIDE BUTTON.
- 3) PUSH OR PULL THE OVERRIDE BUTTON FOR THE DESIRED DIRECTION OF MOVEMENT. THE FARTHER THE BUTTON IS DEPRESSED OR PULLED, THE FASTER THE FUNCTION WILL OPERATE.
- 4) WHEN MANUAL OPERATION IS COMPLETE, RELEASE THE UNLOADER VALVE BUTTON TO ITS ORIGINAL POSITION.

HC-5 NEXSTAR III TROUBLESHOOTING CHART

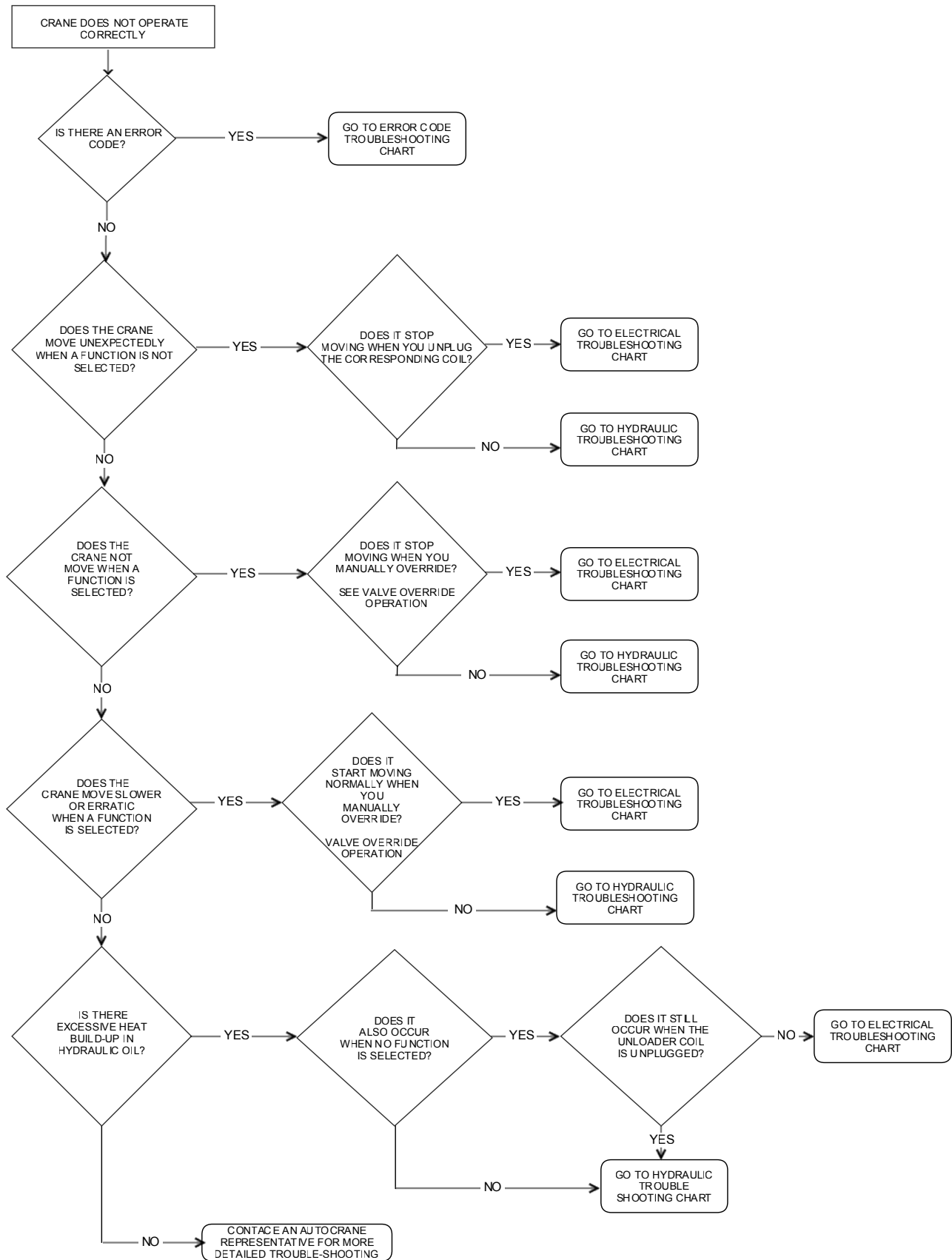

HC-5 NEXSTAR III ERROR CODE CHART

ERROR CODE	CAUSE	EFFECT	SOLUTION
S0 ESTOP ACTIVE	E-STOP ACTIVATED	A I OUTPUTS WILL BE DISABLED	TURN ON TRANSMITTER FOLLOW DE-ACTIVATING E-STOP PROCEDURES ON PAGE 3-3.0
S1 CAN RX TO	RECEPTION OF A CAN MESSAGE TIMED OUT	A I OUTPUTS WILL BE DISABLED	DETERMINE WHY MESSAGE(S) IS(ARE) NOT BEING RECEIVED WHEN PROBLEM IS CORRECTED THE ALARM WILL CLEAR
S2 TEMP OUT OF RANGE	OUTSIDE OPERATING TEMPERATURE --40C TO 85C	A I OUTPUTS WILL BE DISABLED	GET TEMPERATURE INTO ACCEPTABLE RANGE ALARM WILL CLEAR AFTER 1 MINUTE
S16-S31 OUT X OVER-CURRENT ERR	WHEN THE OUTPUT WAS ACTIVATED. A CURRENT OF OVER 3.5 AWAS BEING DRAWN	THAT OUPUT IS DISABLED	CYCLE POWER TO RECEIVER IF PROBLEM CONTINUES. FIND WHAT CAUSED OVERCURRENT DRAW AND CYCLE POWER.
S32-S47 OUT X +VB SHORT	WHEN THE OUTPUT WAS SUPPOSED TO BE A GROUND IT HAD A POSITIVE VOLTAGE	THAT OUTPUT IS DISABLED	DETERMINE THE CAUSE OF THE SHORT. FIX THE CAUSE.AND CYCLE POWER TO RECEIVER
S32-S47 OUT X -VB SHORT	WHEN THE OUTPUT WAS SUPPOSED TO BE A POSITIVE VOLTAGE IT HAD A GROUND	THAT OUTPUT IS DISABLED	DETERMINE THE CAUSE OF THE SHORT, FIX THE CAUSE.AND CYCLE POWER TO THE RECEIVER
A1 BOOM PSI LOW	LIFT CYLINDER PRESSURE BELOW 50 PSI	DISABLES A I FUNCTIONS EXCEPT BOOM UP AND HOIST DOWN	HOIST DOWN LOAD IF APPLICABLE. AND RAISE BOOM OFF ANY SUPPORTS. ALARM WILL CLEAR ONCE PRESSURE IN CYLINDER IS RESTORED.
A2 CW LIMIT	CRANE HAS REACHED THE LIMIT OF ROTATION IN THE CW DIRECTION	DISABLES CLOCKWISE ROTATION	ROTATE CCW TO CLEAR ERROR. ONCE SWITCH IS DEACTIVATED THE ALARM WILL CLEAR.
A3. CCW LIMIT	CRANE HAS REACHED THE LIMIT OF ROTATION IN THE CCW DIRECTION	DISABLES COUNTER-CLOCKWISE ROTATION	ROTATE CW TO CLEAR ERRO. ONCE SWITCH IS DEACTIVATED THE ALARM WILL CLEAR.
AA. TRK TLT WARM	TRUCK ANGLE EXCEEDS 5.7 DEGREES OR 10% SLOPE	A I FUNCTIONS WILL ONLY OPERATE AT 50% OF SPEED	MOVE VEHICLE TO LEVEL GROUND.
AS TRK TILT ALARM	TRUCK ANGLE EXCEEDS 8.5 DEGREES OR 15% SLOPE	A I FUNCTIONS ARE DISABLED	MOVE VEHICLE TO LEVEL GROUND
A6. ANTI 2-BLOCK	ANTI2-BLOCK IS ACTIVATED TRAVELING BLOCK HAS COME NTO CONTACT WITH BOOM	DISABLES BOOM DOWN. EXTEND, AND HOIST UP	MOVE LOAD AWAY FROM BOOM BY EITHER RETRACTING. HOISTING DOWN. OR BOOMING UP IF THERE IS NO LOAD NEAR TIP OF BOOM CHECK FUNCTION OF THE BAIL WELDMENT IT MUST COME INTO CONTACT WITH SWITCH PLUNGER UNDER NORMAL CONDITIONS.
A7 90% LOAD WARN	REACHED 90% OF RATED CAPACITY	REDUCES SPEED OF A I I FUNCTIONS BY 50%	REDUCE LOAD TO CLEAR ALARM
AS. 100% LOAD ALARM	RACHED 100% OF RATED CAPACITY	DISABLES BOOM DOWN EXTEND, AND HOIST UP	REDUCE LOAD BY EITHER RETRACTING, BOOMING UP, OR HOISTING DOWN.
A9 SLOWROTATE ACT	LIFT CYLINDER HAS EXCEEDED 600 PSI	REDUCES ROTATE FUNCTIONS BY 50%	THIS IS A SAFETY FEATURE THAT PREVENTS EXCESSIVE SWINGING OF HEAVY LOADS. WILL RESET WHEN LOAD DECREASES AND FUNCTION IS DEACTIVATED
A10. BOOM SENSOR ERR	BOOM ANGLE SENSOR SIGNAL FAILED	A I FUNCTIONS ARE REDUCED BY 50%	CHECK CONNECTIONS TO BOOM ANGLE SENSOR. VERIFY LIGHTS ARE ON AT SENSOR BASE
A11 BOOMANGL E RANGE	ANGLE SENSOR IS OUT OF RANGE	OPERATES NORMAIIY	BOOM ANGLE SENSOR IS MOUNTED INCORRECTLY CHECK MOUNTING. THE ARROW SHOULD BE FACNG THE TIP OF THE CRANE
A12 BOOM PT ERR	BOOM PRESSURE TRANSDUCER ERROR	A IFUNCTIONS ARE DISABLED EXCEPT BOOM DOWN & HOIST DOWN	CHECK CONNECTIONS TO PRESSURE TRANSDUCER LOCATED ON LFT CYLINDER. CHECK WIRING HARNESS FOR BREAKS

HC-5 NEXSTAR III

ELECTRICAL TROUBLESHOOTING CHART

PROBLEM	POSSIBLE CAUSE	DIAGNOSIS	SOLUTION
CRANE MOVES UNEXPECTEDLY	JAMMED TRANSMITTER BUTTON	ACTIVATE E-STOP TO SEE IF MOVEMENT STOPS	VERIFY THAT NOTHING HAD DEPRESSED THE BUTTON AT THE TIME OF MOVEMENT. IF IT WAS NOT DEPRESSED THEN REPLACE TRANSMITTER
	SHORT IN HARNESS	UNEXPECTED MOVEMENT WOULD ONLY OCCUR WHEN MULTI-FUNCTIONING. UNPLUG COIL TO SEE IF MOVEMENT STOPS. CHECK AMPERAGE TO COIL USING MULTIMETER IN LINE WITH COIL. IT SHOULD BE NO MORE THAN 100mA	TRACE WIRE BACK TO RECEIVER. VERIFY NO DAMAGE TO THE WIRE. CHECK CONNECTORS, THEY SHOULD BE CLEAR OF DEBRIS AND WATER.
	RECEIVER LOCKED UP	BOTTOM RIGHT CORNER IS A CIRCLE WITH AN ARROW. THIS SHOULD BE ROTATING AT ALL TIMES. WHEN THE CRANE IS TURNED ON	IF THE ARROW STOPS ROTATING, SHUT POWER OFF TO THE CRANE. LEAVE OFF 2 MINUTES AND TURN POWER BACK ON. IF THIS PROBLEM PERSISTS CONTACT TECHNICAL SUPPORT
NO FUNCTION OPERATES ON THE CRANE	TRANSMITTER TURNED OFF	SCREEN ON TRANSMITTER IS OFF	TURN ON TRANSMITTER. PULL EMERGENCY STOP OUT.
	E-STOP ACTIVE	CHECK LCD SCREEN YOU WOULD HAVE AN ERROR STATING E-STOP IS ACTIVE	TURN ON TRANSMITTER. PULL EMERGENCY STOP OUT
	RECEIVER TURNED OFF	CHECK THE LCD SCREEN. IF IT IS BLANK, THE RECEIVER IS TURNED OFF	MOST CRANES HAVE A TOGGLE SWITCH TO TURN ON CRANE. THIS IS USUALLY LOCATED IN THE CAB OR THE CRANE BOX.
	LOW BATTERY	WHILE THE TRANSMITTER IS TURNED ON, CHECK THE LCD SCREEN ON RECEIVER. BATTERY INDICATOR SHOULD BE AT LEAST 10%	REPLACE TRANSMITTER BATTERIES. IT REQUIRES (4) AA BATTERIES
	RECEIVER LOCKED UP	BOTTOM RIGHT CORNER IS A CIRCLE WITH AN ARROW. THIS SHOULD BE ROTATING AT ALL TIMES	IF THE ARROW STOPS ROTATING, SHUT POWER OFF TO THE CRANE. LEAVE OFF 2 MINUTES AND TURN POWER BACK ON. IF THIS PROBLEM PERSISTS CONTACT TECHNICAL SUPPORT
	TRUCK TILT ALARM ACTIVE	CHECK SCREEN FOR ERROR CODE. IT WOULD READ TRK TILT ALARM	THIS ERROR OCCURS WHEN THE TRUCK ANGLE EXCEEDS A 15% SLOPE (8.5 DEGREES) RELOCATE THE TRUCK TO A FLATTER SURFACE
THE FOLLOWING FUNCTIONS ARE INOPERABLE BOOM DOWN, EXTEND, HOIST UP	ANTI-2BLOCK	CHECK SCREEN FOR ERROR CODE. IT WOULD READ ANTI-2 BLOCK ERROR.	VERIFY THAT THE TRAVELING BLOCK IS NOT IN CONTACT WITH BAIL. IF SO, HOIST DOWN AND CHECK FUNCTIONS AGAIN. INSPECT END OF BOOM TO VERIFY BAIL IS IN CONTACT WITH ANTI-2 BLOCK SWITCH. CHECK BAIL SPRING. CHECK CORD REEL & WIRE ON SIDE OF CRANE FOR DAMAGE
	CRANE OVERLOAD	CHECK SCREEN FOR ERROR CODE. IT WOULD READ 100% OVERLOAD	VERIFY LOAD ON CRANE DOES NOT EXCEED MOMENT RATING. REFERENCE LOAD CHART. TAP HOIST DOWN OR RETRACT FUNCTION TO RESET OVERLOAD. CHECK OPERATION AGAIN
THE FOLLOWING FUNCTIONS ARE INOPERABLE EXTEND, RETRACT, HOIST UP, BOOM UP, ROTATE CW. & ROTATE CCW	LOW BOOM PRESSURE	CHECK SCREEN FOR ERROR CODE. IT WOULD READ BOOM PSI LOW	VERIFY BOOM IS NOT SUPPORTED BY ANYTHING EXCEPT THE LIFT CYLINDER. THIS WOULD INCLUDE THE BOOM SUPPORT ON THE VEHICLE
ROTATE CW IS INOPERABLE	REACHED LIMIT FOR CLOCKWISE ROTATION	CHECK SCREEN FOR ERROR CODE. IT WOULD READ CW LIMIT	VERIFY THAT THE CW LIMIT SWITCH IS NOT ACTIVATED. THIS SHOULD BE NORMALLY CLOSED
	BAD COIL, OR DAMAGED WIRE	SCREEN WILL SHOW 0% NEXT TO SP BUT THE ROTATE CW FUNCTION WILL BE SHOWN	SWITCH COIL WITH ANOTHER FUNCTION. REPLACE COIL IF BAD, CHECK WIRING FOR ANY DAMAGE
ROTATE CCW IS INOPERABLE	REACHED LIMIT FOR COUNTER CLOCKWISE ROTATION	CHECK SCREEN FOR ERROR CODE. IT WOULD READ CCW LIMIT	VERIFY THAT THE CCW LIMIT SWITCH IS NOT ACTIVATED. THIS SHOULD BE NORMALLY CLOSED
	BAD COIL, OR DAMAGED WIRE	SCREEN WILL SHOW 0% NEXT TO SP BUT THE ROTATE CCW FUNCTION WILL BE SHOWN	SWITCH COIL WITH ANOTHER FUNCTION. REPLACE COIL IF BAD, CHECK WIRING FOR ANY DAMAGE

HC-5 NEXSTAR III

ELECTRICAL TROUBLESHOOTING CHART

PROBLEM	POSSIBLE CAUSE	DIAGNOSIS	SOLUTION
ALL FUNCTIONS ARE INOPERABLE EXCEPT BOOM DOWN AND HOIST DOWN	PESSURE TRANSDUCER IS UNPLUGGED	CHECK LCD SCREEN IT WOULD READ "BOOMPT ERROR"	VERIFY THAT PRESSURE TRANSDUCER LOCATED ON THE LIFT CYLINDER VALVE BLOCK IS PLUGGED INTO THE HARNESS
ANY ONE FUNCTION IS NOT OPERABLE	CUT IN WIRE OR BAD COIL	CHECK THE SCREEN WHEN THE FUNCTION IS SELECTED, IT SHOULD SHOW THE FUNCTION OPERATING BUT 0% OF FUNCTION	SWITCH COIL WITH ANOTHER FUNCTION. REPLACE COIL IF BAD, CHECK WIRING FOR ANY DAMAGE
CRANE ROTATES SLOWLY	SLOW ROTATE ACTIVATED	CHECK LCD SCREEN. IT WOULD READ "SLOW ROTATE ACT"	THIS IS A SAFETY FEATURE TO PREVENT GETTING THE LOAD INTO AN UNSAFE CONDITION (EXCESSIVE SWINGING) SLOW ROTATE WILL REMAIN ACTIVE UNTIL THE LOAD IS REMOVED AND THE ROTATION FUNCTION IS DESELECTED.
	CLOSE TO MAX CRANE LOAD	WHEN THE TRUCK IS TILTED AND UNDER HIGH LOAD A DECREASE IN SPEED IS POSSIBLE	BRING LOAD IN CLOSER TO DECREASE THE LOAD
ALL FUNCTIONS OPERATE SLOWLY	WRONG SPEED FUNCTION IS SELECTED	CHECK THE TRANSMITTER.	ADJUST THE SPEED TO THE PREFERRED SPEED SETTING.
	BOOM ANGLE SENSOR ERROR	CHECK SCREEN FOR ERROR CODE. IT WOULD READ "BOOM SENSOR ERR"	VERIFY THAT THE BOOM SENSOR IS PLUGGED INTO THE HARNESS. CHECK CONNECTION BETWEEN HARNESS AND SENSOR. REMOVE ANY DEBRIS OR WATER FROM CONNECTOR AND RECONNECT
	90% LOAD ACTIVATED	CRANE IS AT OR OVER 90% OF IT'S RATED CAPACITY	THIS IS A SAFETY FEATURE TO PREVENT GETTING INTO AN UNSAFE CONDITION (SUDDEN MOVEMENT OF HEAVY LOAD) 90% LOAD WILL REMAIN ACTIVATED UNTIL LOAD IS DECREASED.
	TRUCK TILT WARNING	CRANE IS BETWEEN A 10% AND 15% SLOPE. CHECK LCD SCREEN FOR ERROR CODE, IT WOULD READ "TRK TILT WARN"	MOVE VEHICLE OR RAISE OUTRIGGER TO A MORE STABLE, LEVEL POSITION.

HC-5 NEXSTAR III ELECTRICAL TROUBLESHOOTING CHART

PROBLEM	POSSIBLE CAUSE	DIAGNOSIS	SOLUTION
CRANE MOVES UNEXPECTEDLY	JAMMED CARTRIDGE	TRY TO MANUALLY OVERRIDE VALVE. IF UNABLE TO MOVE STEM, CARTRIDGE IS JAMMED	REPLACE CARTRIDGE
	COUNTER-BALANCE SET TOO LOW (BOOM-UP & BOOM-DN)	ADJUST THE COUNTER-BALANCE OUT TO SEE IF MOVEMENT STOPS.	CONTACT AUTOCRANE FOR PROPER SETTING OF COUNTER-BALANCE. YOU MAY NEED TO REPLACE COUNTER-BALANCE.
	CONTAMINANT IN CARTRIDGE	VALVE STICKS IN CERTAIN POSITIONS	REFERENCE CARTRIDGE MAINTENANCE FOR CLEANING PROCEDURE
NO FUNCTION OPERATES ON CRANE	PTO NOT ENGAGED	CHECK PTO ACTIVATION LIGHT USUALLY LOCATED IN CAB	ENGAGE PTO
	CRANE DIVERTER VALVE NOT ENGAGED	IF USING AUTOCRANE OUTRIGGERS, CHECK CRANE DIVERTER VALVE LOCATED AT THE OUTRIGGER VALVE.	ENGAGE CRANE DIVERTER VALVE
	HYDRAULIC TANK IS LOW OR EMPTY	VISUALLY INSPECT THE HYDRAULIC OIL LEVEL IN THE TANK	FILL TANK TO PROPER LEVEL.
	VEHICLE IS NOT RUNNING	VERIFY ENGINE IS RUNNING	START VEHICLE
ALL FUNCTIONS OPERATE SLOWLY	FAST IDLE NOT ACTIVATED	IF VEHICLE IS MANUAL TRANSMISSION, VERIFY FAST IDLE IS SHOWN IN THE LCD SCREEN	ACTIVATE FAST IDLE
	FILTER CLOGGED	IF NEXSTAR III, CHECK LCD SCREEN.	REPLACE FILTER
EXCESSIVE HEAT DURING OPERATION	OPERATION TIME	CRANE OPERATION IS GENERALLY DESIGNED FOR INTERMITTENT DUTY (2 HOURS BEFORE OIL GETS HOT)	REDUCE USE OF CRANE, INCREASE HYDRAULIC TANK SIZE, OR ADD OIL COOLER
	UNLOADER VALVE OVERRIDDEN	CHECK UNLOADER VALVE AND VERIFY THE MANUAL OVERRIDE IS NOT ACTIVATED REF. PAGE.	DEACTIVATE UNLOADER VALVE
	UNDERSIZED HYDRAULIC TANK	HYDRAULIC TANK SHOULD BE AT LEAST 2XGPM=GALLONS. THIS INCLUDES ANY OTHER ACCESSORIES THAT OPERATE FROM THE SAME TANK	THIS IS A GENERAL RULE. MANY FACTORS THAT ALSO AFFECT HEAT ARE: AMBIENT TEMPERATURE PRESSURE LOSS, AND OPERATION TIME. FOR EXAMPLE, A SMALLER TANK COULD BE USED WITH MORE INTERMITTENT USE; OR IN COLD ENVIRONMENTS YOU CAN INCREASE TANK SIZE, REDUCE PRESSURE LOSSES OR ADD OIL COOLER.

HC-5 NEXSTAR III CARTRIDGE MAINTENANCE

- Clean the area around the valve spool to be removed from the valve bank
- Remove the valve spool from the valve bank being careful not to touch or hit surrounding objects
- Carefully remove any visible debris from the valve spool
- The recommended cleaning fluid is off-the-shelf automotive brake cleaning fluid.
- It is recommended that skin and eye protection be worn when spraying the valve spool clean.
- Inspect o-rings for damage and replace if needed
- Dip the valve spool into fresh hydraulic oil to lubricate and fill cavities
- Reinstall the valve spool in the reverse order in which it was removed
- Validate function operation of the crane



VERIFY MOVEMENT IN PORTS WHILE
MANUALLY OVER-RIDING CARTRIDGE.

HC-5 NEXSTAR III LOAD CHART

P/N: 361106539

HC-5

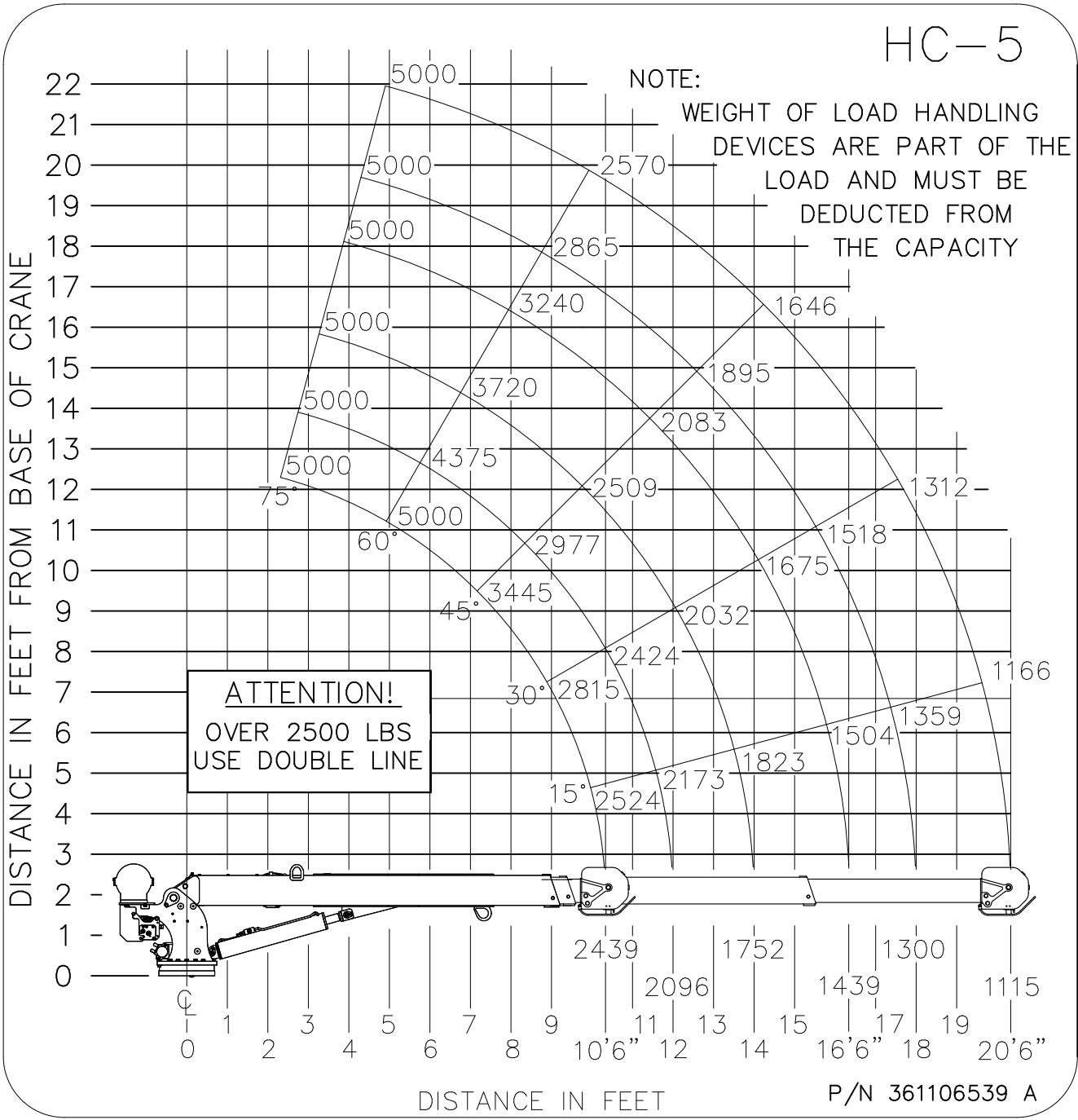

CRANE

PREVENTATIVE MAINTENANCE

PAIN T FINISH PREVENTIVE MAINTENANCE INSTRUCTIONS

The paint finish on Auto Crane products can become damaged during normal use when chipped, scratched, exposed to harsh chemicals, cleaned with high pressure washers, etc. During periods when the truck is exposed to salt or other corrosive chemicals, Auto Crane products should be washed weekly. The paint finish should be inspected when washed or at least monthly. Any exposed bare metal or visible rust should be repaired immediately. Damaged paint on cranes should be repaired by:

1. Sanding the damaged areas to bare metal.
2. Solvent cleaning the sanded areas to remove sanding residue. Wipe dry with a clean cloth to remove any remaining residue.
3. Priming the sanded areas to a minimum of a 2 mil dry film thickness per the primer manufacturer's instructions. The primer must be compatible with Sherwin Williams' E2W932 epoxy primer.
4. Applying a 2 mil dry film thickness top coat paint per the manufacturer's instructions within 24 hours of applying the primer. The top coat paint must be compatible with Sherwin Williams' E2W932 epoxy primer and Sherwin Williams' Genesis polyurethane top coat paint. The final primer and top coat should have approximately a 4 mil dry film thickness.



P.O.Box 580697 • Tulsa, OK 74158-0697
4707 N. Mingo Rd. • Phone (918) 438-2760

LIMITED WARRANTY 1 YEAR PURCHASED REPLACEMENT PARTS

Auto Crane will warranty to the consumer for a period of (1) year from the date that a new Auto Crane replacement part was purchased from an authorized Auto Crane distributor. Each new Auto Crane part they sell will be free under normal use and service from defects in material and workmanship. Date of purchase will be honored as the date indicated on the Bill of Sale to the consumer.

The obligation of Auto Crane under this warranty does not apply to parts replaced under the limited warranty for a new Auto Crane product. The warranty for parts replaced under the limited warranty of a new Auto Crane product expires when the warranty for that product expires.

The obligation of Auto Crane under this warranty is limited to the replacement or repair of purchased replacement parts that appear to the manufacturer to be defective after review of documentation (Auto Crane Warranty Claim Form, photos, data etc.) provided by the Auto Crane distributor and/or inspection of parts returned to Auto Crane. This warranty does not obligate Auto Crane to bear labor costs to replace the defective parts or travel time charges in connection with the replacement or repair of defective parts. Responsibility for customer's claims arising from misapplication, abuse, misuse or alteration of equipment or parts lies with the distributor or user and no warranty obligation is assumed in these circumstances by Auto Crane.

Auto Crane will in no event be liable for any consequential damages or contingent liabilities arising out of the failure of any Auto Crane product or parts to operate properly

Auto Crane makes no warranty in respect to parts for component accessories, it being subject to the warranties of their respective manufacturers.

If field service, at the request of the distributor, is rendered and fault is found not to be with Auto Crane's product, the distributor shall pay the time and expense of the field representative.

Claims for service labor or other expenses that have incurred by the buyer without approval or authorization or Auto Crane will not be accepted

When applying for warranty claims may be handled by contacting your nearest authorized Auto Crane **Distributor. All claims are to be filed in writing on an Auto Crane Warranty Claim Form.**



P.O. Box 580697 • Tulsa, OK 74158697
4707 N. Mingo Rd. • Phone (918) 836-0463

LIMITED WARRANTY 2 YEAR PARTS AND LABOR

Auto Crane will warranty to the consumer for a period of (2) years parts and labor from the date of purchase. Each new Auto Crane unit they sell will be free under normal use and service from defects in material and workmanship. Date of purchase will be honored as the date indicated on the Bill of Sale, which must accompany the Warranty Registration and be on file with Auto Crane. Absent a valid Warranty Registration and appropriate documentation, the original date of manufacture, as indicated by the serial number on the product, will be used to determine the effective date of the 2 year warranty.

The obligation of Auto Crane under this warranty is limited to the replacement or repair of parts that appear to the manufacturer after review and/or inspection to be defective and paid flat rate labor for replacing defective parts. This warranty does not obligate Auto Crane to bear the travel time charges in connection with the replacement or repair of defective parts. Responsibility for customer's claims arising, from misapplication, abuse, misuse or alteration of equipment or parts lies with the distributor or user and no warranty obligation is assumed in these circumstances by Auto Crane.

Auto Crane will in no event be liable for any consequential damages or contingent liabilities arising out of the failure of any Auto Crane Product or parts to operate properly.

Auto Crane makes no warranty in respect to component accessories, it being subject to the warranties of their respective manufacturers.

If field service, at the request of the distributor, is rendered and fault is found not to be with Auto Crane's product, the distributor shall pay the time and expense of the field representative.

Claims for service labor or other expenses that have incurred by the buyer without approval or authorization or Auto Crane will not be accepted.

When applying for warranty, claims may be handled by contacting your nearest authorized Auto Crane Distributor. All claims are to be filed in writing on an Auto Crane warranty Claim Form.

AUTO CRANE COMPANY IS UNDER NO OBLIGATION TO EXTEND THIS WARRANTY TO ANY CUSTOMER FOR WHICH AN AUTO CRANE DELIVERY REPORT FORM HAS NOT BEEN COMPLETED AND ON FILE WITH AUTO CRANE COMPANY

Note: This manual should remain with the crane at all times.

Auto Crane will not assume responsibility or liability for any modifications or changes made to unit, or installation of component parts without authorization.

Auto Crane Company issues a limited warranty certificate with each unit sold. See warranty page.

