

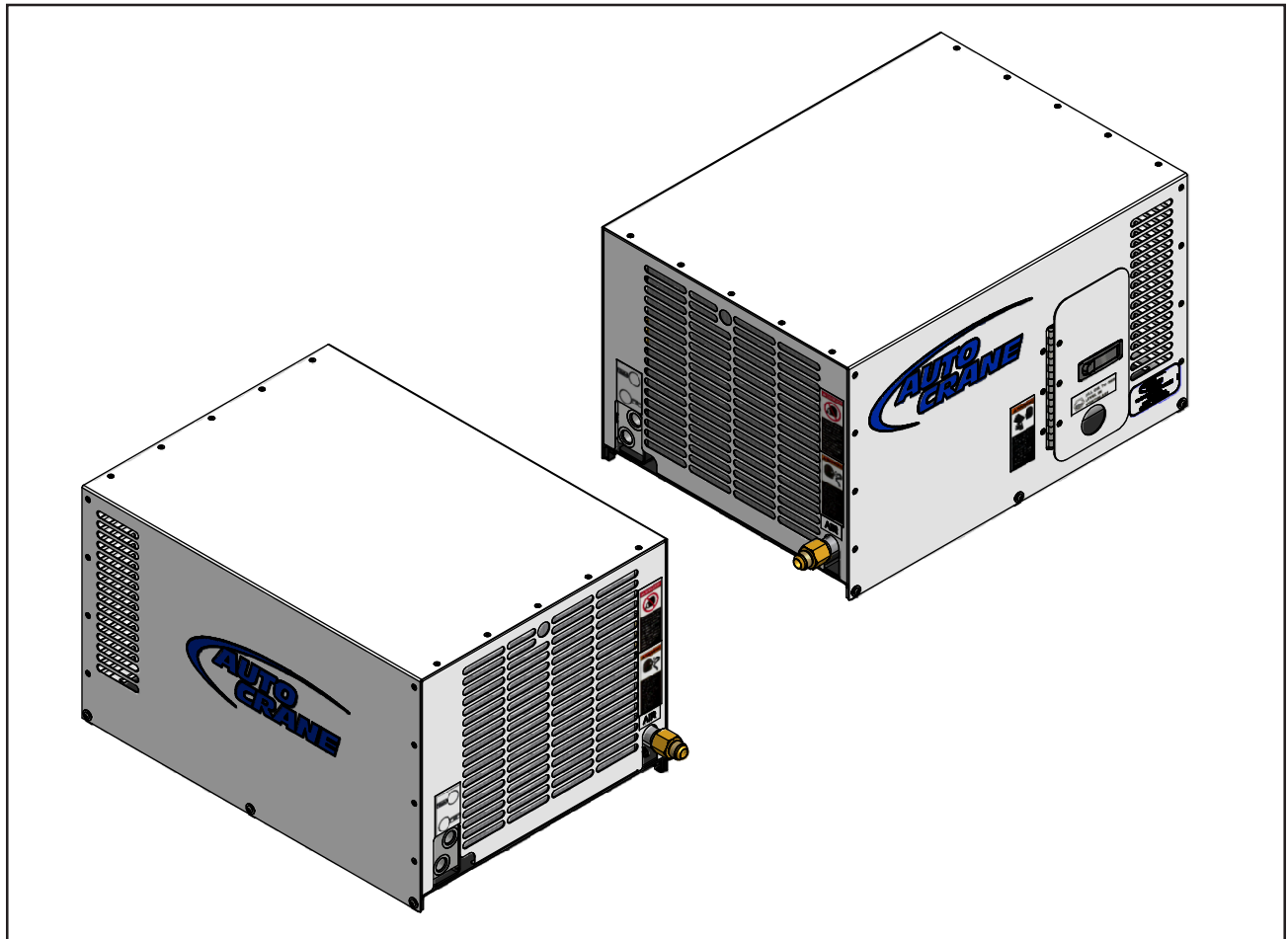

Service and
Maintenance
User Manual

Auto Crane
AC40 Piston
Hydraulic Air Compressor



This manual must be read carefully before using your Auto Crane Air Compressor.
Store in a safe and convenient location for future reference.

For technical support:

Phone: (918) 836-0463

Fax: (918) 834-5979

<http://www.autocrane.com>

755501900
8/19/2013 CRH

Contents

Revision List	5
Welcome	6
Safety Information	7
Warnings, safety rules, and hazards.....	7
Specifications	10
Description of Components	11
Installation & Operation	12
Installation.....	12
Before Starting.....	14
Initial Start-up & Test.....	16
Maintenance	17
Overview.....	17
Recommended Spare Parts List.....	17
Maintenance Schedule.....	18
Lubrication Recommendation.....	19
Compressor Oil	20
Air Intake Filter.....	20
Hydraulic Oil Cooler.....	21
Troubleshooting	22
General Tips.....	22
Contacting Auto Crane.....	23
Where To Find Specific Machine Information.....	23

Drawings	25
Frame System.....	26
Piston System.....	28
Piston Assembly.....	30
Cooler System.....	32
Hydraulic Drive System.....	34
Discharge System.....	36
Canopy System.....	38
Decal System.....	40
Wiring Diagram.....	42
 Warranty	 43

Revision List

DATE	LOCATION	DESCRIPTION OF CHANGE	INITIALS

Welcome

General Information

Thank you for choosing the Auto Crane AC40 Hydraulic Air Compressor. Before operating this compressor, read over this manual and become well acquainted with your new machine. Doing this will increase your safety and maximize the life of the machine.

While this manual is written to be as accurate as possible, Auto Crane strives to continually improve the efficiency and performance of its machines. As a result, sometimes there may be slight differences between a given version of the manual and the machine.

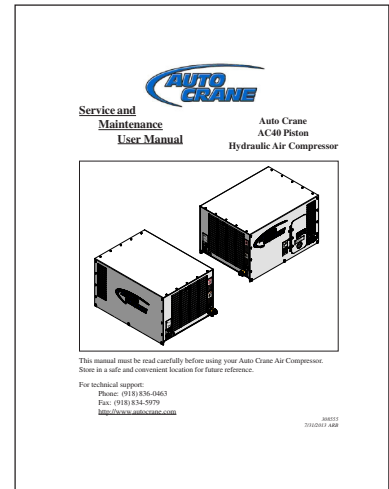

Auto Crane AC40 Hydraulic Air Compressor

The Auto Crane AC40 is a compact, strategically designed system. It integrates all major components on a single frame, which is enclosed in a tough, weather-resistant canopy.

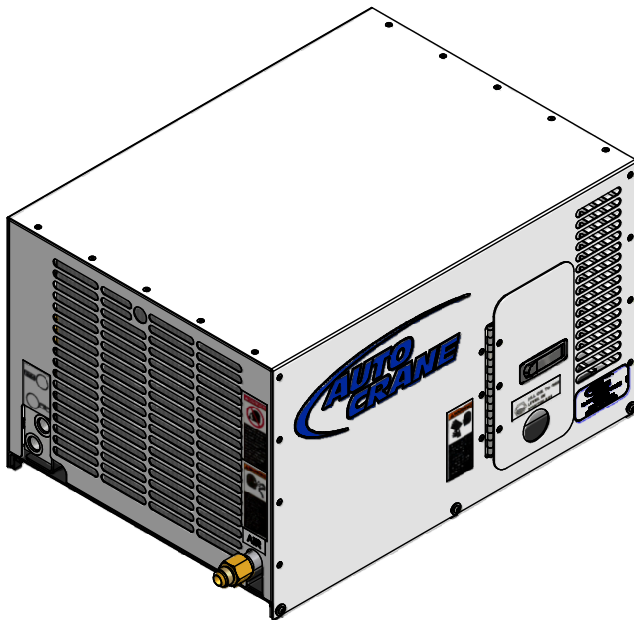

The AC40 Piston design provides output of up to 40 CFM (cubic feet of air per minute) at up to a maximum of 150 PSI (pounds per square inch). High output at relatively low GPM (gallons per minute) translates into the most efficient, quiet, and reliable system in its class, designed to handle virtually any application.

The AC40 Piston also has enhanced safety features offering applications designed to protect your most valuable resource - your operating crew. To prevent overheating, a high temperature switch will shut down the machine in the event of high discharge temperatures.

Safety

IMPORTANT READ BEFORE OPERATING EQUIPMENT

Remember, safety is basically common sense. While there are standard safety rules, each situation has its own peculiarities that cannot always be covered by rules. Therefore with your experience and common sense, you are in a position to ensure your and others safety. Lack of attention to safety can result in: accidents, personal injury, reduction in efficiency and worst of all – Loss of Life. Watch for safety hazards and correct them promptly.

Understanding the proper operation of this equipment is critical to its safe operation. The owner, lessor or operator of this equipment is hereby notified and forewarned that any failure to observe the safety and operating guidelines may result in injury and/or damage. Auto Crane expressly disclaims responsibility or liability for any injury or damage caused by failure to observe these specified precautions or by failure to exercise the ordinary caution and due care required while operating or handling this equipment, even though not expressly specified.

In addition to following these safety guidelines, the operator should follow any company specific guidelines and procedures. Consult your immediate supervisor for specific company safety guidelines and/or procedures.

The following safety symbols are used throughout the manual to draw attention to important information. If the information is not carefully read and the instructions are not followed, severe injury, death, and/or damage to property and equipment may occur.



Indicate[s] an imminently hazardous situation, which, if not avoided, **will** result in death or serious injury.



Indicate[s] a potentially hazardous situation, which, if not avoided, **could** result in death or serious injury.



Indicate[s] a potentially hazardous situation, which, if not avoided, **could** result in minor or moderate injury.



Indicate[s] a potentially unsafe situation or practice, which, if not avoided can result in property and/or equipment damage only.

Safety

The following safety precautions are a general guide to safe operation of the equipment.



WARNING

Read and understand the operations manual and all other safety instructions before using this equipment. Failure to follow operating instructions and/or failure to follow maintenance procedures and intervals could result in personal injury, death, and/or damage to equipment and property.



DANGER

Pressurized System. Do not attempt to remove any compressor parts without first completely relieving entire system of pressure. Do not attempt to service any part of the equipment while in operation. Never attempt to repair or modify any pressure vessel or device.



DANGER

System contains hot oil. The compressor system must be shut off prior to servicing. Open the service valve to ensure complete relief of system air pressure and stored energy. Then permit system to cool down prior to adding compressor oil or servicing the unit.



DANGER

Do not use air from this compressor for breathing or food processing. Air from this compressor will cause severe injury if used for breathing or food processing.



DANGER

The compressor is designed to compress air only. Do not attempt to compress other gases. Compression of other gases may create a situation where an explosion or fire may occur.



DANGER

Do not use flammable solvents for cleaning compressor parts as this can cause the unit to ignite or explode during operation. Keep combustibles out of and away from compressor inlet, and any associated enclosures.

Safety

DANGER

Never disable, override, or remove safeties, either temporarily or permanently.

DANGER

Connect air hoses only in full compliance with OSHA Standard 29 CFR 1926:302 (b)(7). The required safety devices (velocity fuses) should be tested in accordance with their manufacturer's recommendations to verify that they reduce pressure in case of hose failure and will not nuisance trip with the hose and tool combinations in use. Failure to comply could result in personal injury or death and/or damage to equipment and property.

DANGER

Never leave the machine running unattended or leave a tool connected to an air hose when not using. Relieve system of all stored air pressure after use.

WARNING

Never adjust the pressure switch to a setting of greater than 150 PSI. Operating the compressor at greater than 150 PSI may result in personal injury and property damage.

CAUTION

Mount the compressor in a stable location capable of supporting 180 lbs. Slight vibration may occur during operation and the machine may move if not securely mounted.

CAUTION

When using tools, maintain secure footing at all times. Do not overreach or awkwardly use air tools.

NOTICE

Prior to moving vehicle to the next work site, drain the air tank. To prevent the collection of water in the tank drain daily.

NOTICE

Use only Auto Crane approved replacement parts.

Specifications

POWER SOURCE	HYDRAULIC MOTOR	OPERATING SPEED	1650 RPM MAX.
CYLINDER CONFIG.	V4 Piston	OIL CAPACITY	1 1/3 QTS
DIMENSIONS	28 1/2"L x 17"H x 20 7/8"W	WEIGHT	180 LBS.
DELIVERY @ 100 PSI	40 CFM	HYDRAULIC RESERVOIR REQ. *	20 GALLON MINIMUM
COOLING	AIR	NORMAL GPM @ 1650 RPM	12.18 GPM
FAN DIAMETER	14 1/8"	NORMAL OPERATING PSI	1450 PSI
MAXIMUM PSI	2100 PSI		

* Hydraulic reservoir requirement for compressor only. Additional capacity will be needed for other hydraulic equipment.

SPECIFICATIONS SUBJECT TO CHANGE WITHOUT PRIOR NOTICE

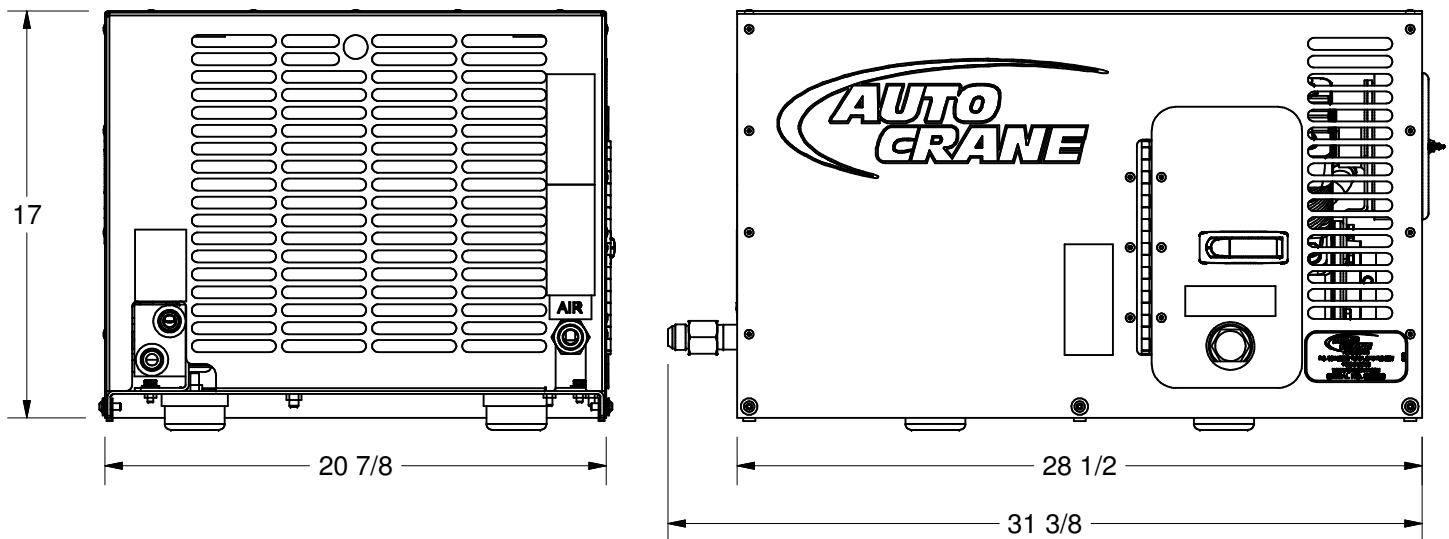

- AC40 system is to run intermittently.
- When the AC40 is installed with other hydraulic drive equipment it will require a dedicated flow line.
- If other hydraulics are required, the hydraulic reservoir size should be at least 20 GAL for the AC40 plus all the other manufacturer's requirements.
- Mounting surface must be capable of 180 lbs. load spread over the four mounting holes.
- Cooling air intake must not see air temperatures above ambient.
- Cooling air discharge must have 10" clearance from any obstructions.
- Ambient running conditions: -20° to 100° F.
- 20° maximum operating slope.

Description of Components

Compressor Assembly - The Auto Crane AC40 hydraulic drive piston compressor assembly is a positive displacement, intermittent-flow, reciprocating unit. The piston compressor consists of a crankshaft, oil filter, oil pump, four connecting rods, pistons, cylinders, and valve assemblies. As the crankshaft rotates, the pistons move up and down. As they move down, a vacuum is created above the piston which allows the reed valve to open and fill the area above the piston with air. When the pistons move back up, this air is discharged from the compressor. Oil lubricates the bearings and cylinder walls as the crankshaft rotates, ensuring that the system stays cool.

Hydraulic Oil Cooling Systems - The compressor cooling system consists of a hydraulic cooler mounted on the compressor frame. Cool air is drawn through the vented end panel and flows over the compressor surface and through the hydraulic cooler, exiting out the front vented panel. Allow for adequate clearance (10") for the air to exit. Also, the package location should not be subjected to air temperatures above ambient.

Fluid Level Sight Glass - This sight glass indicates the fluid level in the crank case. Proper level should be in the middle of the sight glass. Check this level when the compressor is disengaged and the vehicle is parked on level ground. Fluid level should be checked prior to each use.

Electrical System - The Auto Crane compressor's standard electrical system consists of:

- Hydraulic oil cooler fan assembly and relay.
- 12VDC N.O. hydraulic solenoid.
- Switch relay for customer equipment interface during compressor operation.

Most air tools operating pressure range is between 90 and 125 psi. Operating above the tools' recommended pressures will decrease the life of the tool. Higher operating pressure can also over torque nuts and bolts fatiguing the fastener and mating parts. Strictly adhere to tool operating pressures and torque standards set forth by the tool manufacturer and the specifications of the equipment that work is being performed on.

CAUTION

Pressure Switch - The pressure switch is a N.C. electrical switch set to open at 150 PSI and set to close at 115 PSI. The pressure switch controls the N.O. hydraulic solenoid. If service air pressure is under 150 PSI, the pressure switch will remain in its normally closed state, keeping the N.O. hydraulic solenoid closed and the compressor producing air. If the service valve is closed or the tool using the air is off, service line pressure will rise to 150 PSI. This will cause the pressure switch to open and deactivate the hydraulic solenoid. The compressor will stop making air. If the tool is turned on or the service valve is opened, the service line pressure will drop. When the pressure falls to 115 PSI, the pressure switch will close, energizing the N.O. hydraulic solenoid forcing flow to the motor and the compressor will start producing air to meet the demand.

WARNING

Never adjust the pressure switch to a setting of greater than 150 PSI. Operating the compressor at greater than 150 PSI may result in personal injury and property damage.

Installation & Operation

This air compressor should be installed only by those who have been trained and delegated to do so and who have read and understand the manual. Failure to follow the instructions, procedures, and safety precautions in this manual may result in accidents and injuries.

Install, use, and operate this air compressor only in full compliance with all pertinent O.S.H.A., Federal, State, and Local codes or requirements in addition to Auto Crane and any company's regulations.

Do not modify this compressor except with written factory approval.

NOTICE

ALL TRUCKS SHOULD BE ROAD TESTED PRIOR TO STARTING INSTALLATION TO ISOLATE ANY PREVIOUS TRUCK PROBLEMS.

1. Mounting the Compressor

When mounting the compressor care should be taken to ensure that its location does not impede the operation of other components on the vehicle. For example, if your vehicle is equipped with a crane, you must make sure the compressor will not interfere with the swing of the crane. In addition, the compressor should be installed in an area that permits cool ambient air to enter the air filter and the hot air to exhaust without recirculating into the air filter. 10" of exhaust clearance is needed. The compressor air filter is mounted on the frame. Cool ambient air is drawn in from under the frame. One last consideration in the mounting should be the routing of hoses and electrical wires. The frame mounting holes are shown below and the unit should be secured to the vehicle with 3/8 inch grade 8 bolts and washers. Hardware supplied with unit, may not work in all applications. The compressor weighs 180 lbs. Ensure that you have a sub structure to support at least that weight. Be sure to follow all National Vehicle Safety Standards.

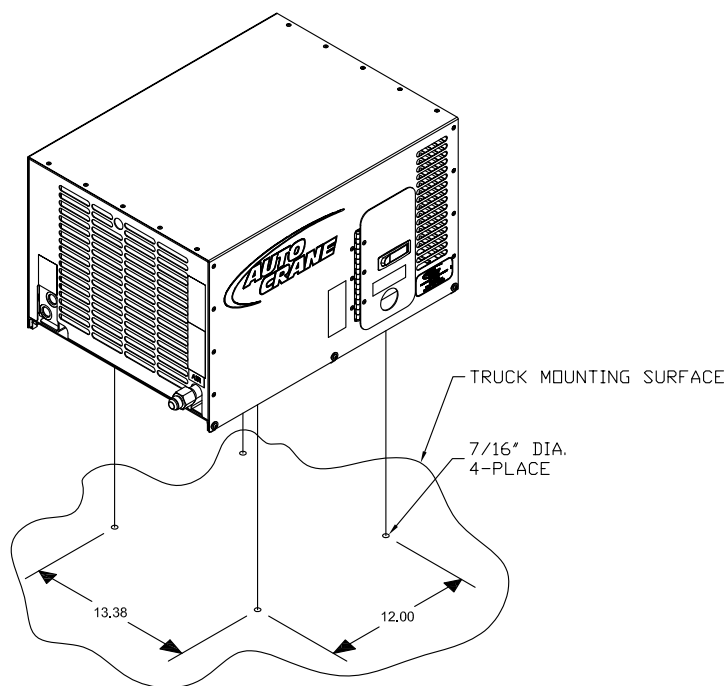

Installation & Operation

2. Installing the Wiring

This unit is shipped from the factory with all necessary internal wiring installed. The only remaining wiring necessary is the wiring needed to interface your vehicle/power source with the Auto Crane compressor. The unit is shipped with a 4 pin connector, they need to be connected as follows:

1. Pin “A” and Pin “D” are to be connected directly to battery positive (Pin “A”) and battery negative (Pin “D”).
2. Compressor Only: for normal compressor operation, supply 12VDC inputs to Pin “B”. This will activate the system and pressure the tank to 150 PSI. The system will then unload until the tank has dropped to 115 PSI, at which point it will automatically activate. The 12VDC output signal from Pin “C” will be present only when the system is compressing.

3. Connecting the Hydraulic Hoses

The hydraulic hoses to the compressor should be connected directly to the hydraulic fittings. The fittings are 3/4” JIC. The pressure “P” input line should be made from a good quality high pressure hydraulic hose 1/2” or 3/4” I.D. rated to handle the hydraulic systems on the vehicle. The return line to tank “T” can be made from a medium pressure (min. 1000 PSI) hydraulic hose 3/4” I.D. Care should be taken to see that the hoses are not installed with kinks or bends that inhibit flow of the hydraulic oil. Lack of flow could result in damage to the motor and compressor. Lastly check to make sure hoses are not in contact with sharp objects or edges that may fray, chafe or cut them over time. Secure all hoses with tie down straps or clamps.

4. Connecting the Air Hose

The air discharge hose should be connected directly to the “AIR” port. The fitting is a 1/2” female NPT. The air line should be made from a good quality (min. 200 PSI) hydraulic hose 1/2” or 3/4” I.D. Care should be taken to see that the hose is not installed with kinks. When adding an air hose, ensure OSHA Regulation 1910.169 is followed.

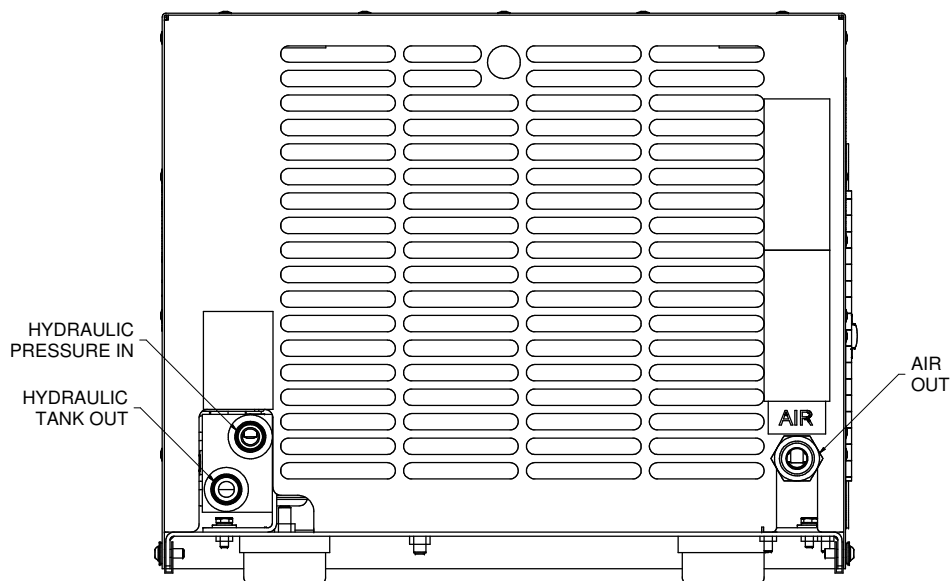

Installation & Operation

WARNING

A compressor service valve should be located at the hose reel inlet or the customer's air connection port when a hose reel is not used. Typical plumbing from the machine's air outlet port occurs in the following order:

1. Air tank
2. OSHA valve.
3. Service valve.
4. Moisture trap/gauge/oiler combination (when used).
5. Hose reel (when used).

5. Pre-Start-up Inspection Checks

This inspection should be done prior the compressor test.

- I. Check all assemblies, clamps, fittings, hose connections, nuts, and bolts to ensure they are properly tied and secured to the vehicle. This is a very critical area of inspection. The vehicle should not be moved until this inspection has been completed.
- II. Remove all tools, rags, and installation equipment from the area.
- III. Check compressor oil level and hydraulic fluid level. Check all valves to ensure they are in correct operating position.
- IV. Apply decals to proper location. Make sure that the area is cleaned prior to applying decals. All decals should have a professional appearance upon application.
- V. Vacuum all areas that have metal or plastic shavings. Wipe all fingerprints off unit and vehicle.

Installation & Operation

V. Record all serial numbers for this installation.

A. Vehicle V.I.N.

B. Hydraulic Pump Data

C. Compressor Serial Number

D. Auto Crane Serial Number

E. Air Tank Serial Number

F. Note any special applications relating to specific installations.

VI. Check all fluid levels (position the unit on a level surface so that proper amount of fluids can be added).

A. Fuel to provide three hours of operation.

B. Hydraulic fluid levels may have to be topped off after test.

C. Compressor.

Check the compressor oil level (see lubricant section of the operator and parts section for type of lubricant to use). 1. Add oil if needed. 2. Additional oil may need to be added after test. 3. Top off oil level to half the sightglass when finished with the test.

D. Any other applicable fluids.

E. Transmission fluid and PTO box.

Installation & Operation

6. Operating Procedure

- I. Read the operation section in the manual carefully before proceeding onto the initial start-up.
- II. Start power source and allow for warm-up.
- III. Verify the compressor is disengaged.
- IV. Engage hydraulic system per company policy.
- V. Engage compressor.

7. Shutdown Procedure

- I. Disengage compressor circuit.
- II. Relieve system of stored air.

Operating Conditions

The following conditions should exist for maximum performance of the compressor. The truck should be as close to level as possible when operating. Operation in ambient temperatures above 100°F (38°C) may experience high temperature shutdown.

Maintenance

This section contains instructions for performing the inspection, lubrication, and maintenance procedures required to maintain the compressor in proper operating condition. The importance of performing the maintenance described herein cannot be over emphasized.

The periodic maintenance procedures to be performed on the equipment covered by this manual are listed on the following page. It should be understood that the intervals between inspections specified are maximum interval. More frequent inspections should be made if the unit is operating in a dusty environment, in high ambient temperature, or in other unusual conditions. A planned program of periodic inspection and maintenance will help avoid premature failure and costly repairs. Daily visual inspections should become a routine.

⚠ DANGER

Compressor must be shut down and completely relieved of pressure prior to checking fluid levels. Open service valve to ensure relief of system air pressure. Relieve all stored air pressure energy prior to starting machine. Failure to comply with this warning will cause damage to property and serious bodily harm.

Recommended Spare Parts List

PART NUMBER	DESCRIPTION
755501344	KIT, REPAIR REED VALVE
755501213	ELEMENT, AIR FILTER
755901000	SPIDER, CURVED JAW
755501506	KIT, REPAIR HYD MOTOR SEAL

How To Order Parts

For Parts and/or Service Support:

Phone: (918) 836-0463
Fax: (918) 834-5979
<http://www.autocrane.com>

Maintenance

The LUBRICATION AND MAINTENANCE CHART lists serviceable items on this compressor package. The items are listed according to their frequency of maintenance, followed by those items which need only “As Required” maintenance.

Lubrication and Maintenance Chart

SERVICE INTERVAL	MAINTENANCE OPERATION
DAILY	<ol style="list-style-type: none">1. Check crankcase oil level. Add if needed.2. Drain condensation from air receiver.
WEEKLY	<ol style="list-style-type: none">1. Inspect the air intake.2. Check the cylinder head stud torque (see NOTE 2).3. Check the operation of the receiver safety valves.
EVERY 3 MONTHS	<ol style="list-style-type: none">1. Change the crankcase oil (see NOTE 1).2. Check cooler fins for dirt and obstruction. Clean if needed.
EVERY 6 MONTHS	<ol style="list-style-type: none">1. Inspect the drive coupling for wear.2. Change the air cleaner.

Use only Auto Crane’s synthetic compressor oil. The use of any other oil causes excessive carbon buildup, and may void the warranty on the compressor.

NOTE 1.

Under normal operating conditions, oil changes are required every 3 months. When operating in a dirty environment, change the oil and air filter more frequently as your particular operating conditions dictate. Compressor oil capacity is 1-1/3 quarts.

NOTE 2.

Cylinder head stud torque **MUST** be checked after the initial day of operation. The compressor must be cold (room temperature) before re-torquing of studs. Torque studs to 240 in-lbs plus or minus 10 in-lbs.

Maintenance

Lubrication Recommendations

CAUTION

It is important that the compressor oil be of a recommended type and that this oil as well as the air filter element be inspected and replaced as started in this manual.

The following are general characteristics for a piston lubricant. Due to the impossibility of establishing limits on all physical and chemical properties of lubricants which can affect their performance in the compressor over a broad range of environmental influences, the responsibility for recommending and consistently furnishing a suitable heavy duty lubricant must rest with the individual supplier if they choose not to use the recommended Auto Crane Piston lubricant. The lubricant supplier's recommendation must, therefore, be based upon not only the following general characteristics, but also upon his own knowledge of the suitability of the recommended lubricant in piston air compressors operating in the particular environment involved.

	UNIT	METHOD	RATING
ISO VISCOSITY GRADE		ISO 3448	46
KINEMATIC VISCOSITY		ASTM D445	
- AT 40°C (104°F)	mm ² /s		46
- AT 100°C (212°F)	mm ² /s		7.7
DENSITY AT 15°C (59°F)	g/mL	ASTM D1298	.843
FLASH POINT (COC)	°C (°F)	ASTM D92	235 (455)
POUR POINT	°C (°F)	ASTM D97	<-45 (-49)
VISCOSITY INDEX (VI)		DIN ISO 2909	135
RUST PREVENTION PROPERTIES		ASTM D665-B	PASS
WATER SEPERABILITY	min	ASTM D1401	10
ROTATING PRESSURE VESSEL OXIDATION TEST	min	ASTM D2272	2200
FZG LOAD CARRYING TEST	FAILURE LOAD STAGE	CEC-L-07-A-95	>12

NOTICE

Mixing different types or brands of lubricants is not recommended due to the possibility of a dilution of the additives or a reaction between additives or different types.

Maintenance

NOTICE

Due to environmental factors, the useful life of all “extended life” lubricants may be shorter than quoted by the lubricant supplier. Auto Crane encourages the user to closely monitor the lubricant condition and to participate in an oil analysis program with the supplier.

NOTICE

No lubricant, however good and/or expensive, can replace proper maintenance and attention. Select and use it wisely.

Compressor Oil Fill, Level, and Drain

Before adding or changing compressor oil, make sure that the compressor is completely relieved of pressure. Oil is added at the fill cap on the side of the compressor body. A drain line is located opposite the service door. The proper oil level is in the middle of the oil sightglass, when the unit is shut down and has had time to settle. The truck must be level when checking the oil. **DO NOT OVERFILL.** The oil capacity is given in “Compressor Specifications”.

⚠ DANGER

Do not attempt to drain condensate, remove the oil level fill cap, or break any connection in the air or oil system without shutting off the compressor and relieve the system of all stored air pressure.

Air Intake Filter (P/N 755501213)

The air intake filter is a heavy-duty dry type high efficiency filter designed to protect the compressor from dust and foreign objects.

Frequency of maintenance of the filter depends on dust conditions at the operating site. The filter element must be serviced when clogged. A clogged air filter element will reduce compressor performance and cause premature wear of components.

Maintenance

HYDRAULIC OIL COOLER

The interior of the oil cooler should be cleaned when the pressure drop across it at full flow exceeds 25 PSI.

1. Remove cooler.
2. Circulate a suitable solvent to dissolve and remove varnish and sludge.
3. Flush generously with hydraulic oil.
4. Once the cooler is reinstalled, fill the hydraulic system with the proper fluid to their appropriate levels.

Troubleshooting

The troubleshooting procedures to be performed on the equipment are listed below. Each symptom of trouble for a component or system is followed by a list of probable causes of the trouble and suggested procedures to be followed to identify the cause.

In general, the procedures listed should be performed in the order in which they are listed, although the order may be varied if the need is indicated by conditions under which the trouble occurred. In any event, the procedures which can be performed in the least amount of time and with the least amount of removal or disassembly of parts, should be performed first.

LOW OIL PRESSURE

1. Low oil level.
2. Loose pipe plug on oil pump cover.
3. Worn or defective oil pump.
4. Crack or scratch on oil pump cover.

NO OIL PRESSURE

1. Defective oil pump
2. Blocked oil passage.
3. Damage oil pump drive pin.

COMPRESSOR WILL NOT ENGAGE

1. No power supplied to compressor.
2. Internal circuit breaker tripped.
3. Hydraulic system not engaged.
4. Defective pressure switch.

COMPRESSOR ENGAGES BUT WILL NOT PRESSURIZE TANK

1. Air leak in plumbing.
2. Worn piston rings or valve plates.

COMPRESSOR DOES NOT RECOVER PRESSURE AS FAST AS IT SHOULD

1. Dirty filter.
2. Air leak in plumbing.
3. Worn valve plates or piston rings.

Troubleshooting

Contacting Auto Crane

Phone: (918) 836-0463

Fax: (918) 834-5979

<http://www.autocrane.com>

When calling for technical support, have the following information available:

Machine Serial Number

Description of the problem

How To Find Specific Machine Information

The machine serial number can be found on the Auto Crane serial tag located on the side of machine.

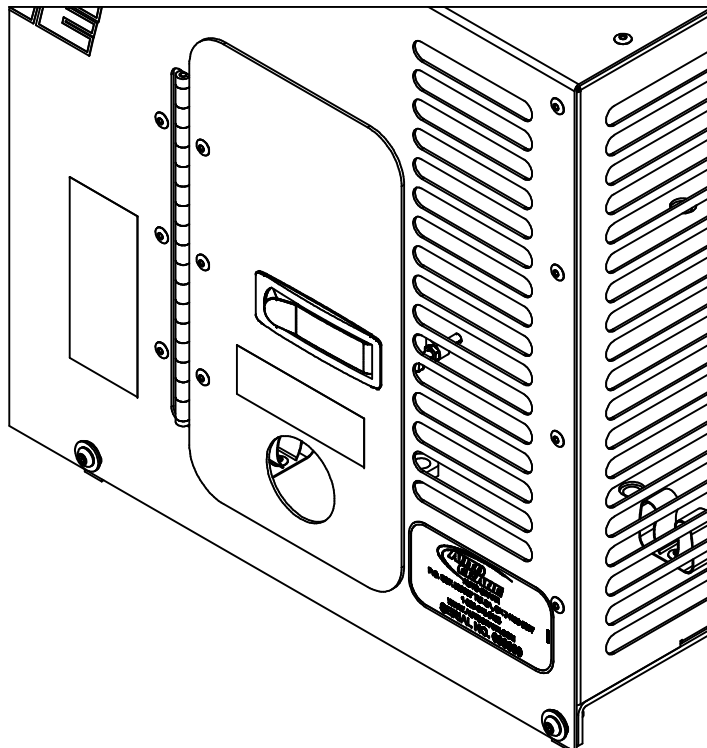

**PARTS AND
ILLUSTRATION
SECTION**

Frame System

Reference Drawing - 755501100

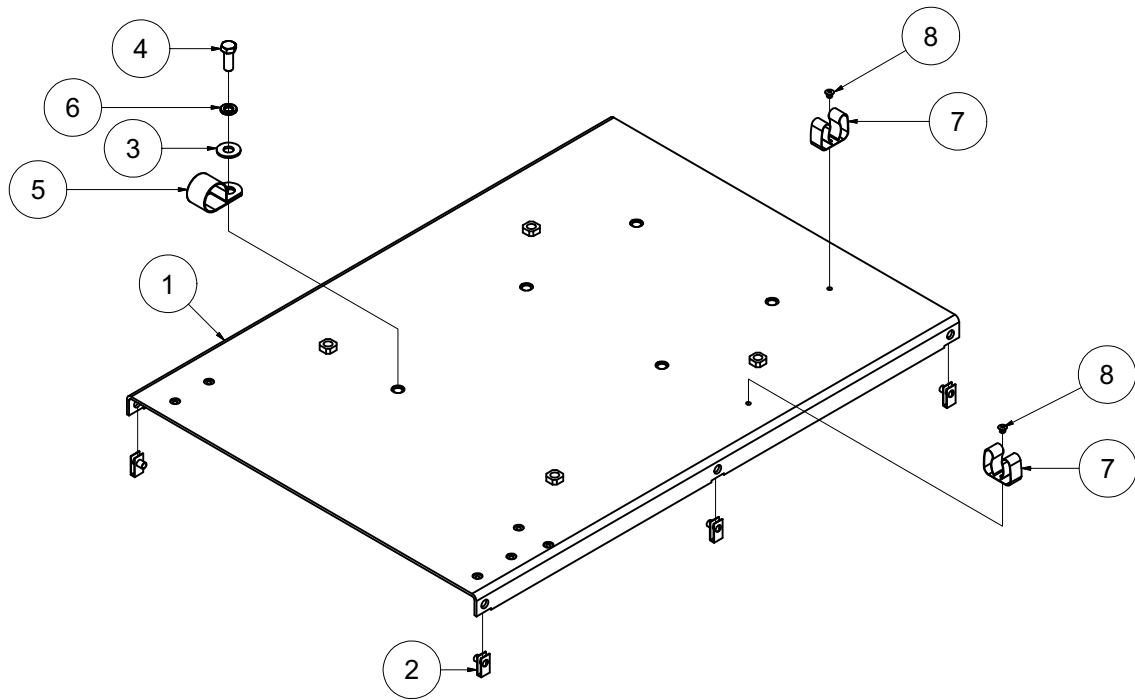

Frame System

Reference Drawing - 755501100

Parts List			
ITEM	QTY	PART NUMBER	DESCRIPTION
1	1	755501101	FRAME
2	6	755500037	NUT
3	1	320976000	WASHER
4	1	330371000	BOLT
5	1	755501104	CLAMP
6	1	755501105	WASHER
7	2	755501106	CLIP
8	2	755501107	RIVET

Piston System

Reference Drawing - 755501200

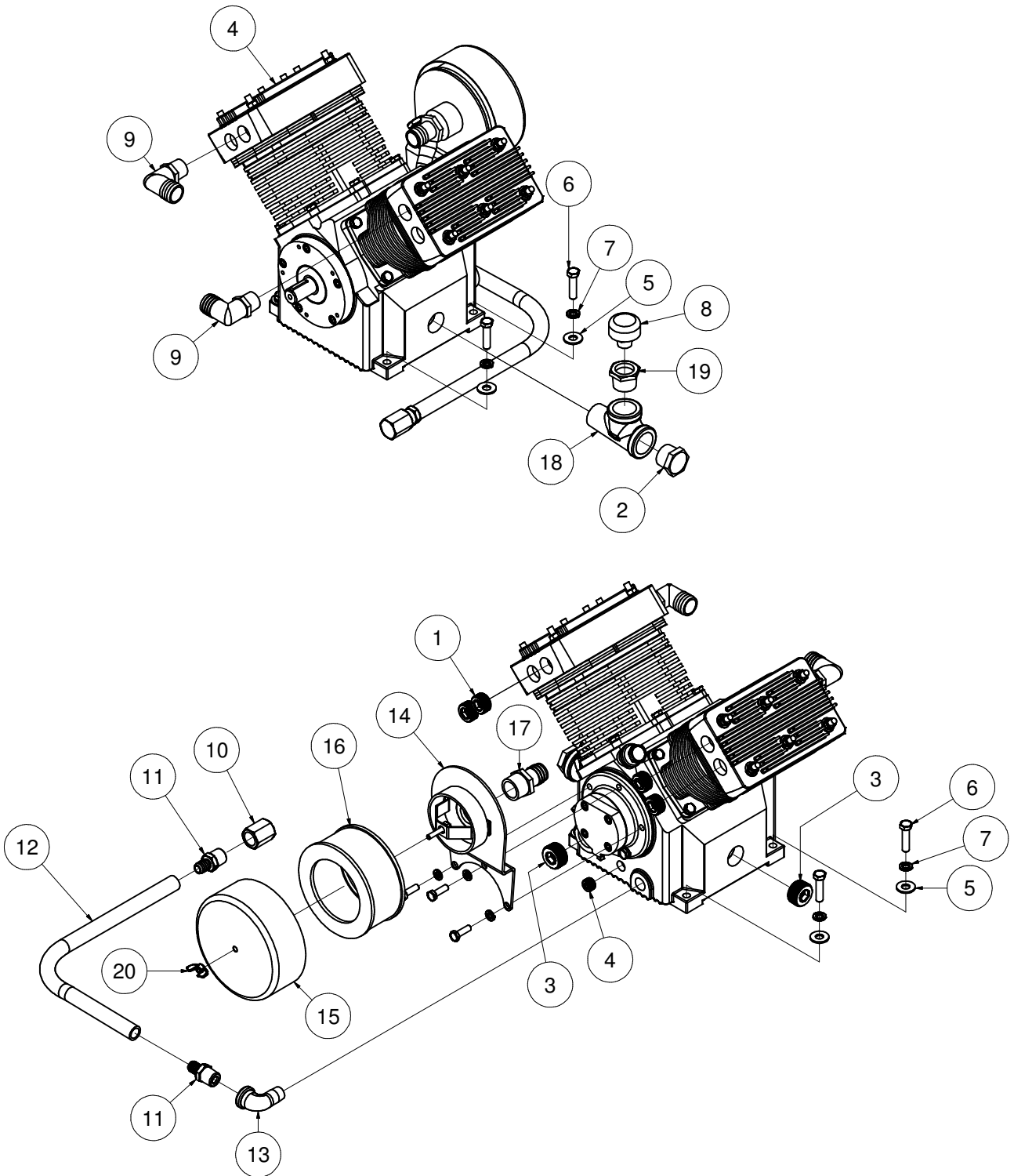

Piston System

Reference Drawing - 755501200

Parts List			
ITEM	QTY	PART NUMBER	DESCRIPTION
1	4	755501201	PLUG
2	1	755501202	SIGHTGLASS
3	2	755501203	PLUG
4	1	755501204	PISTON
5	4	320976000	WASHER
6	4	366159000	BOLT
7	4	755501105	WASHER
8	1	755501205	CAP
9	2	755501206	ELBOW
10	1	755501207	CAP
11	2	755501208	FITTING
12	1 1/2 ft	755501209	HOSE
13	1	755501210	ELBOW
14	1	755501211	BRACKET
15	1	755501212	CAP
16	1	755501213	ELEMENT
17	1	755501214	ADAPTER
18	1	755501215	TEE
19	1	755501216	BUSHING
20	1	755501217	NUT

Piston Assembly

Reference Drawing - 755501300

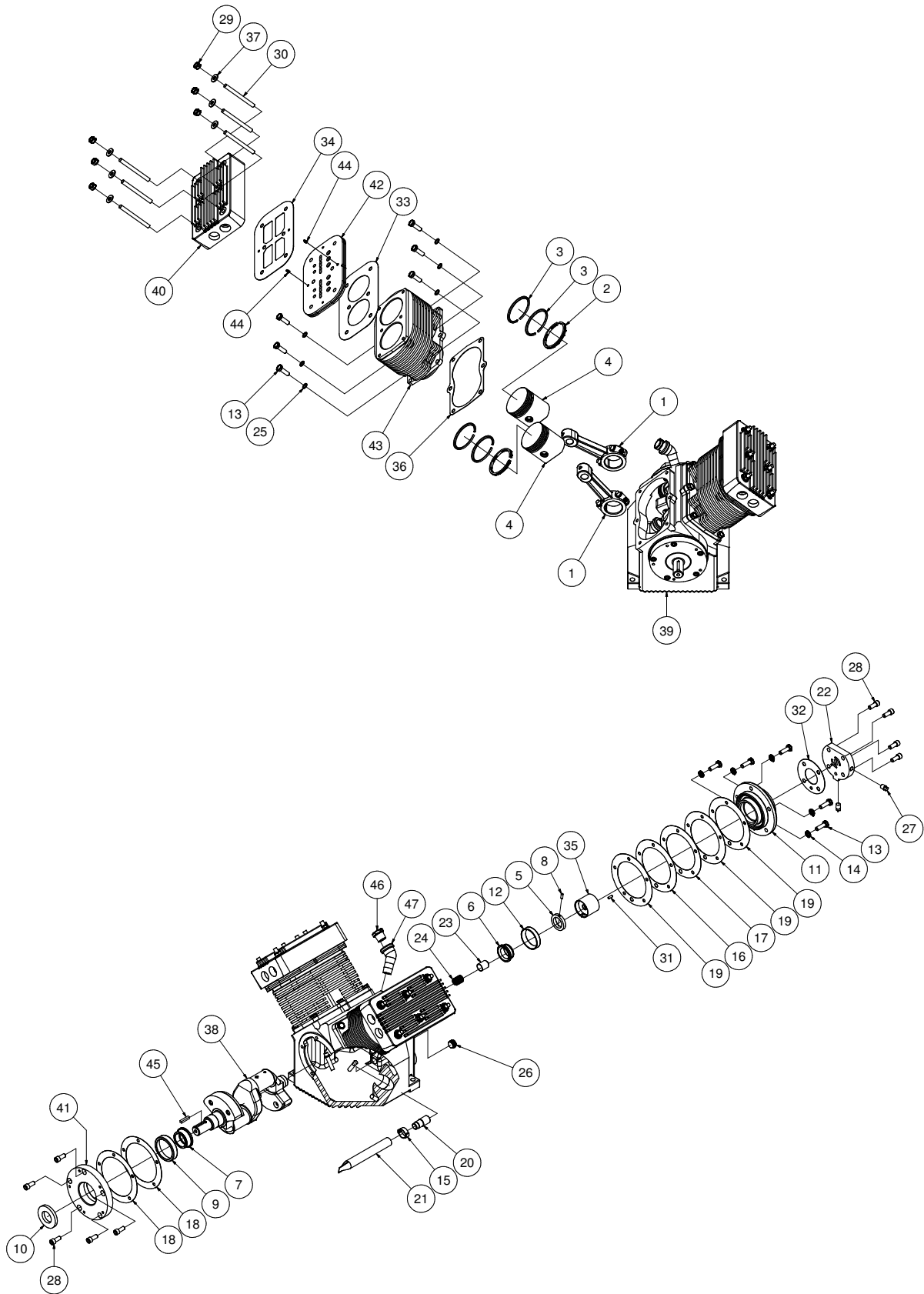

Piston Assembly

Reference Drawing - 755501300

Parts List			
ITEM	QTY	PART NUMBER	DESCRIPTION
1	4	755501301	ROD
2	4	755501302	RING
3	8	755501303	RING
4	4	755501304	PISTON
5	1	755501305	COLLAR
6	1	755501306	BEARING
7	1	755501307	BEARING
8	1	755501308	PIN
9	1	755501309	BEARING
10	1	755501310	SEAL
11	1	755501311	HOUSING
12	1	755501312	BEARING
13	17	007400000	BOLT
14	5	020600000	WASHER
15	1	755501313	CLAMP
16	1	755501314	GASKET
17	1	755501315	GASKET
18	2	755501316	GASKET
19	3	755501317	GASKET
20	1	755501318	TUBE
21	1	755501319	SCREEN
22	1	755501320	COVER
23	1	755501321	BUSHING
24	1	755501322	SPRING
25	12	755501323	WASHER
26	1	755501324	PLUG
27	2	755501325	PLUG
28	9	755501326	BOLT
29	12	016500000	NUT
30	12	755501327	STUD
31	1	755501328	PIN
32	1	755501329	GASKET
33	2	755501330	GASKET
34	2	755501331	GASKET
35	1	755501332	PUMP
36	2	755501333	GASKET
37	12	020300000	WASHER
38	1	755501334	CRANKSHAFT
39	1	755501335	CRANKCASE
40	2	755501336	HEAD
41	1	755501337	HOUSING
42	2	755501338	REED VALVE ASSY
43	2	755501339	CYLINDER BLOCK
44	4	755501340	PIN
45	1	755501341	KEY
46	1	755501342	PLUG
47	2	755501343	ELBOW

Cooler System

Reference Drawing - 755501400

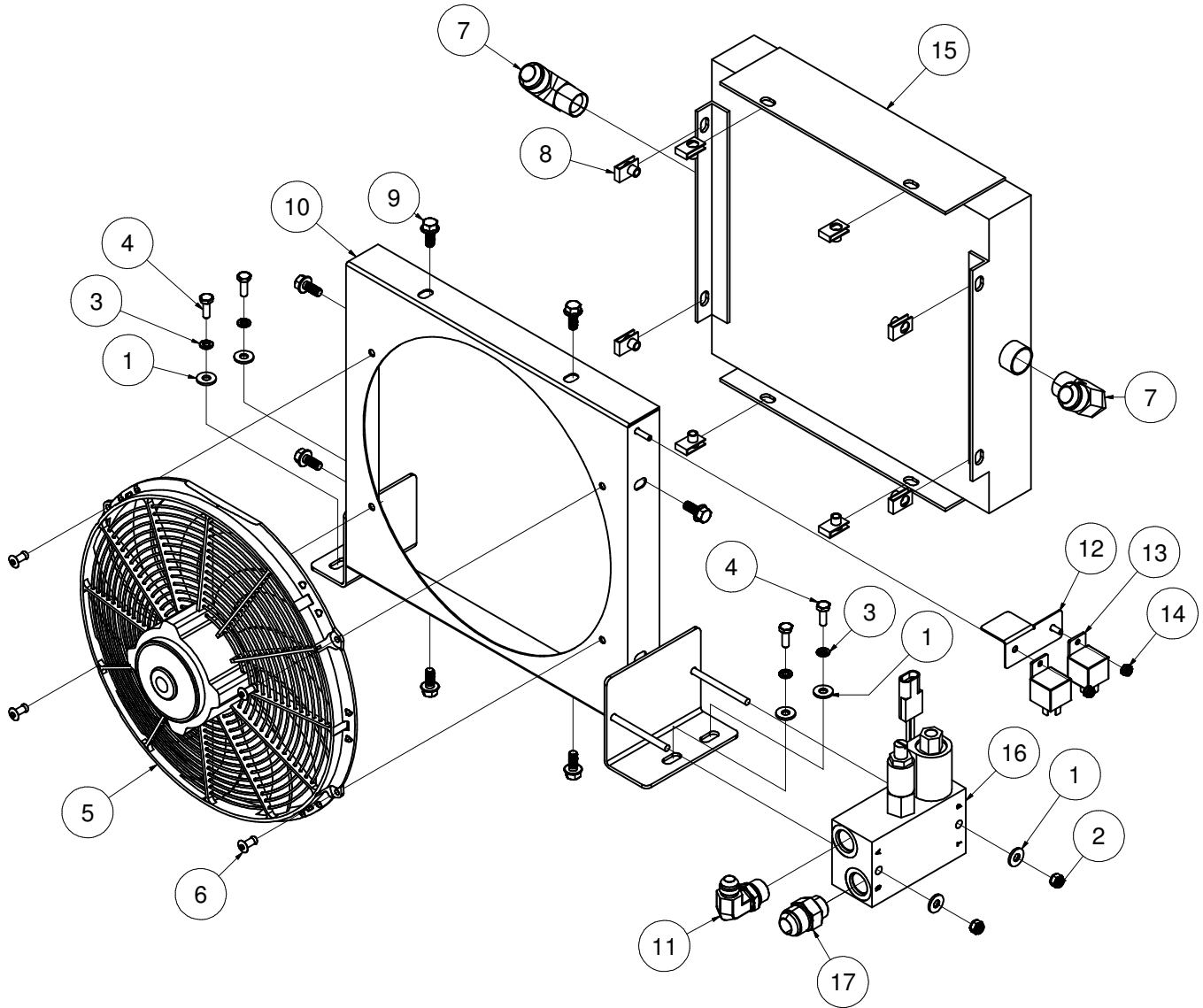

Cooler System

Reference Drawing - 755501400

Parts List			
ITEM	QTY	PART NUMBER	DESCRIPTION
1	6	020300000	WASHER
2	2	016300000	NUT
3	4	020200000	WASHER
4	4	005500000	BOLT
5	1	755501401	FAN ASSY
6	4	755501402	RIVET
7	2	755501403	ELBOW
8	8	755500061	NUT
9	7	755501404	BOLT
10	1	755501405	SHROUD
11	1	755501406	ELBOW
12	1	755501407	BRACKET
13	2	755500039	RELAY
14	2	015800000	NUT
15	1	755501408	COOLER
16	1	755501409	BLOCK
17	1	755501410	CONNECTOR

Hydraulic Drive System

Reference Drawing - 755501500

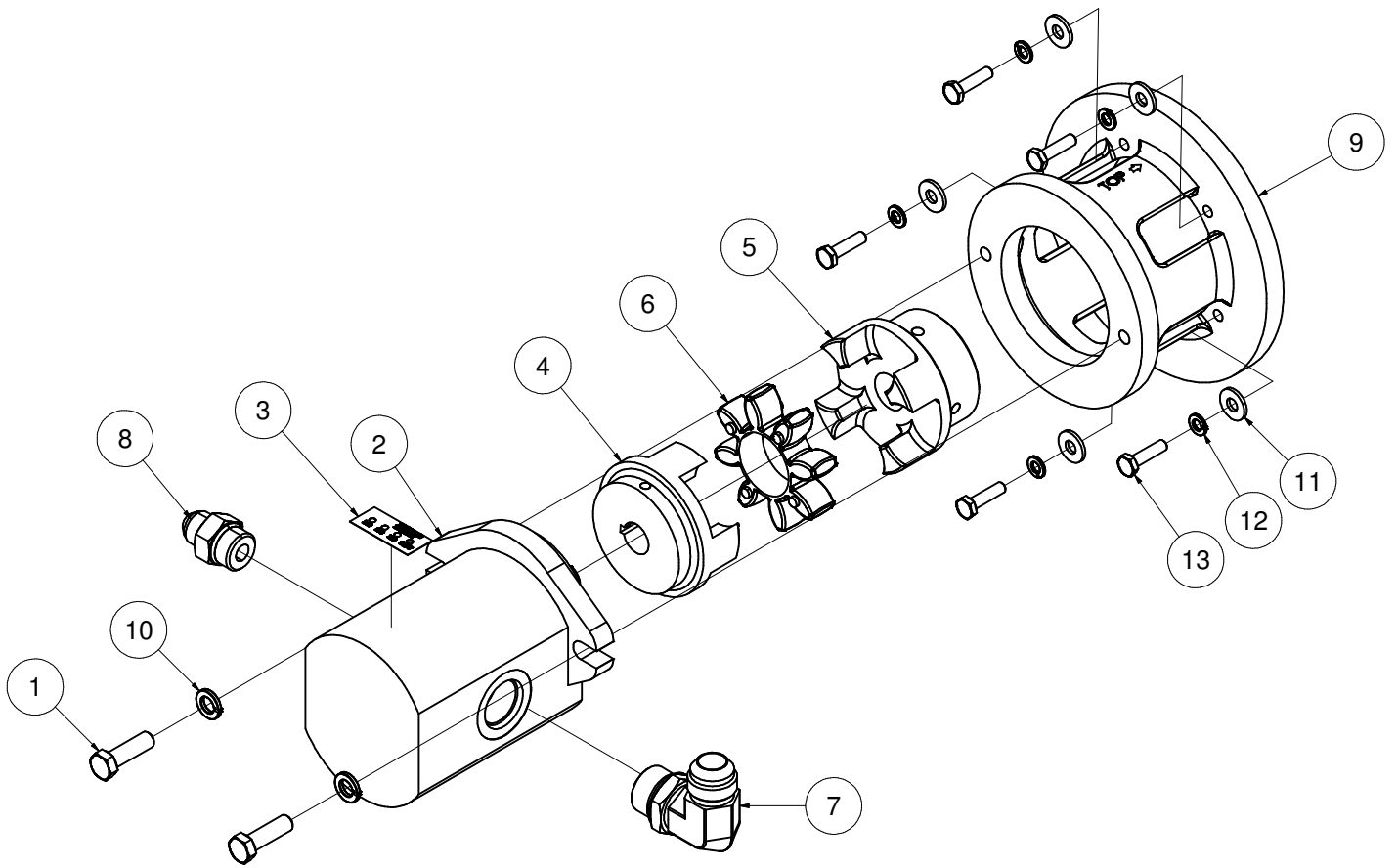

Hydraulic Drive System

Reference Drawing - 755501500

Parts List			
ITEM	QTY	PART NUMBER	DESCRIPTION
1	2	008702000	BOLT
2	1	755500010	MOTOR
3	1	755500057	DECAL
4	1	755501501	HUB
5	1	755501502	HUB
6	1	755901000	SPIDER
7	1	755501503	ELBOW
8	1	755501504	CONNECTOR
9	1	755501505	ADAPTER
10	2	755501105	WASHER
11	5	020300000	WASHER
12	5	020200000	WASHER
13	5	005604000	BOLT

Discharge System

Reference Drawing - 755501600

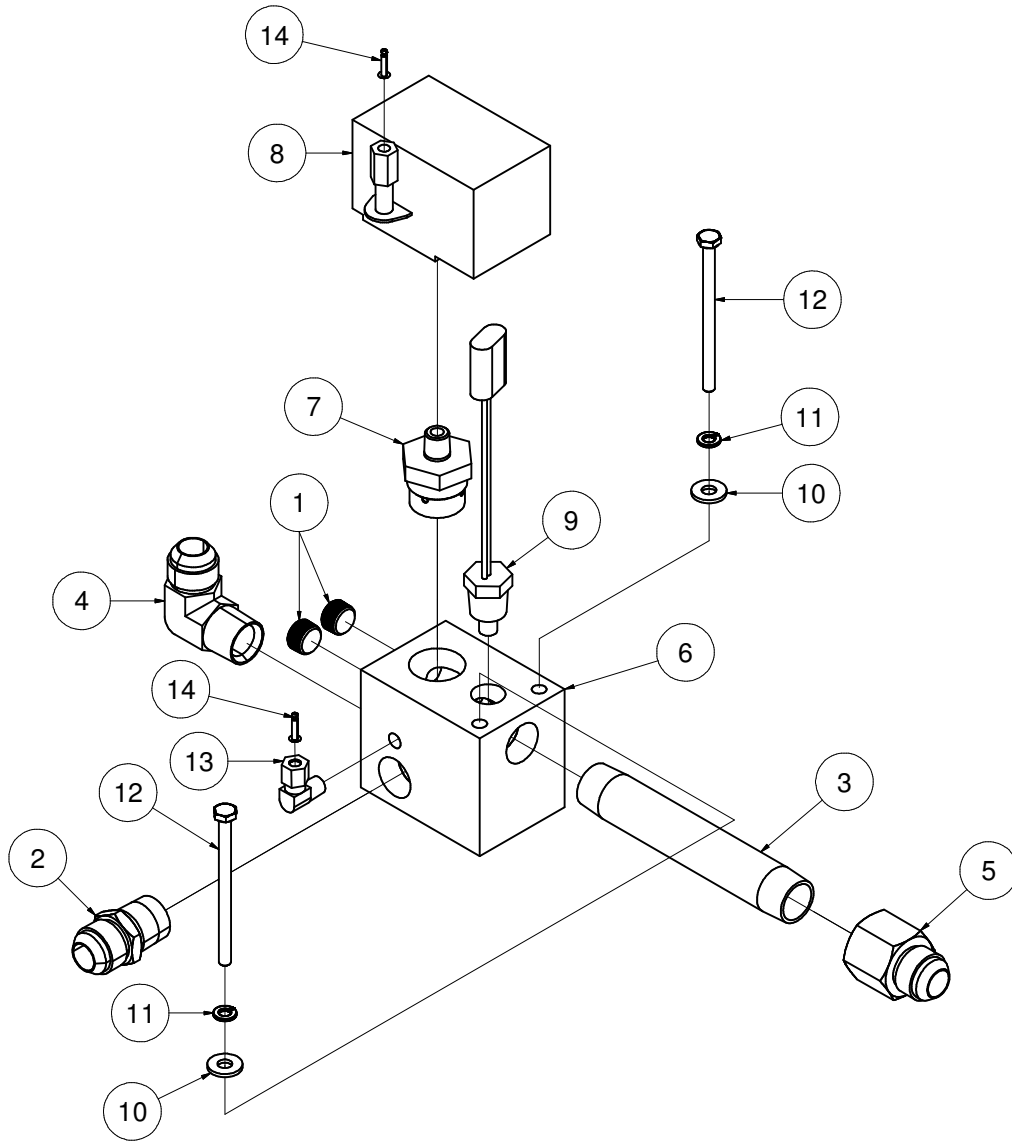

Discharge System

Reference Drawing - 755501600

Parts List			
ITEM	QTY	PART NUMBER	DESCRIPTION
1	2	755501324	PLUG
2	1	755501601	CONNECTOR
3	1	755501602	NIPPLE
4	1	755501403	ELBOW
5	1	755501603	ADAPTER
6	1	755501604	BLOCK
7	1	755501605	CAP
8	1	755501606	SWITCH
9	1	755501607	SWITCH
10	2	020300000	WASHER
11	2	020200000	WASHER
12	2	755501608	BOLT
13	1	755501609	ELBOW
14	2	755501610	RIVET

Canopy System

Reference Drawing - 755501700

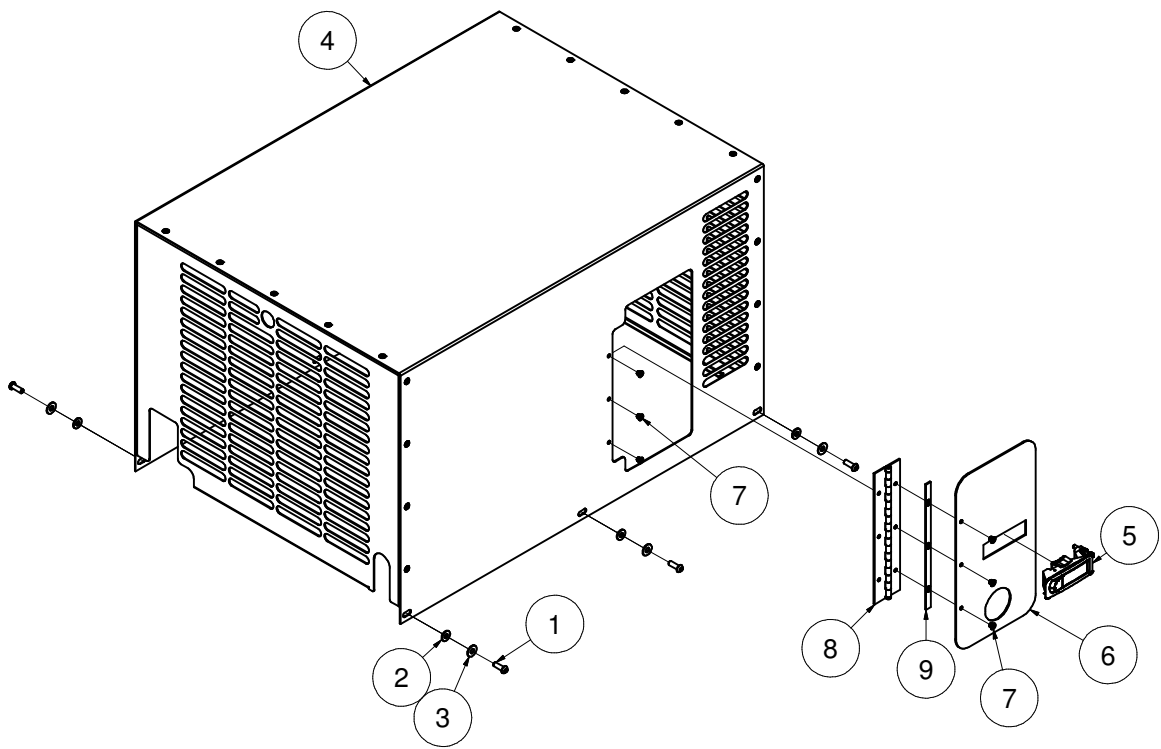

Canopy System

Reference Drawing - 755501700

Parts List			
ITEM	QTY	PART NUMBER	DESCRIPTION
1	6	755501701	BOLT
2	6	755501702	WASHER
3	6	755501703	WASHER
4	1	755501704	CANOPY ASSY
5	1	755921000	LATCH
6	1	755501705	PANEL
7	6	755501107	RIVET
8	1	755501706	HINGE
9	1	755501707	SPACER

Decal System

Reference Drawing - 755501800

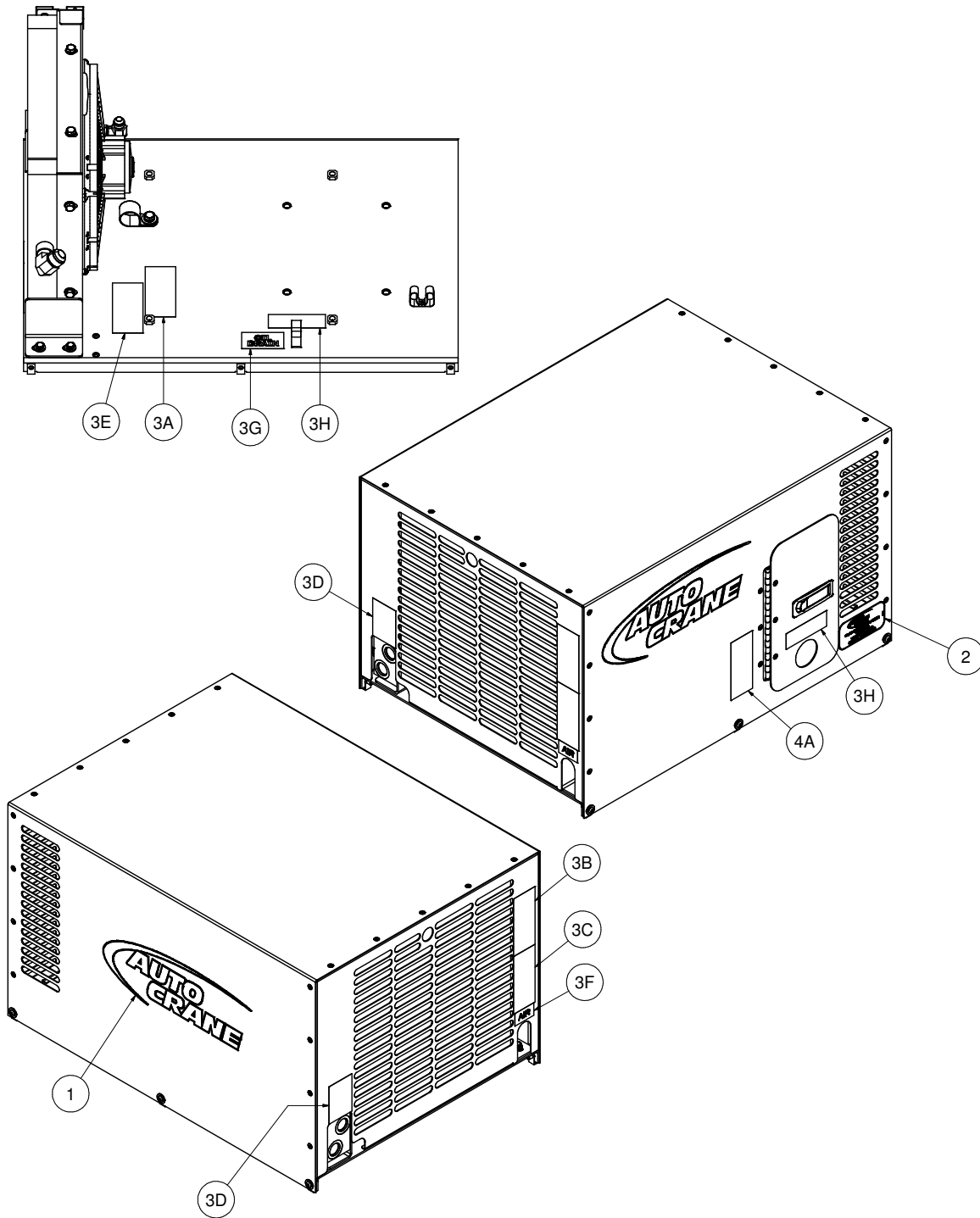

Decal System

Reference Drawing - 755501800

Parts List			
ITEM	QTY	PART NUMBER	DESCRIPTION
1	2	755500053	DECAL, AUTO CRANE
2	1	755501801	DECAL, SERIAL TAG AUTOCRANE
3	1	755501802	DECAL, 36 BHP SHEET
3A	1		DECAL, DRIVE COUPLING
3B	1		DECAL, DANGER BREATHING
3C	1		DECAL, WARNING CONNECT AIR
3D	1		DECAL, HYD PRESS & TANK
3E	1		DECAL, WARNING FAN GUARD
3F	1		DECAL, AIR LEXAN
3G	1		DECAL, OIL DRAIN
3H	2		DECAL, COMPR SIGHT GLASS
4	1	755501803	KIT, AC40 DECAL SHEET
4A	1		DECAL, WARNING READ MANUAL

System Schematic

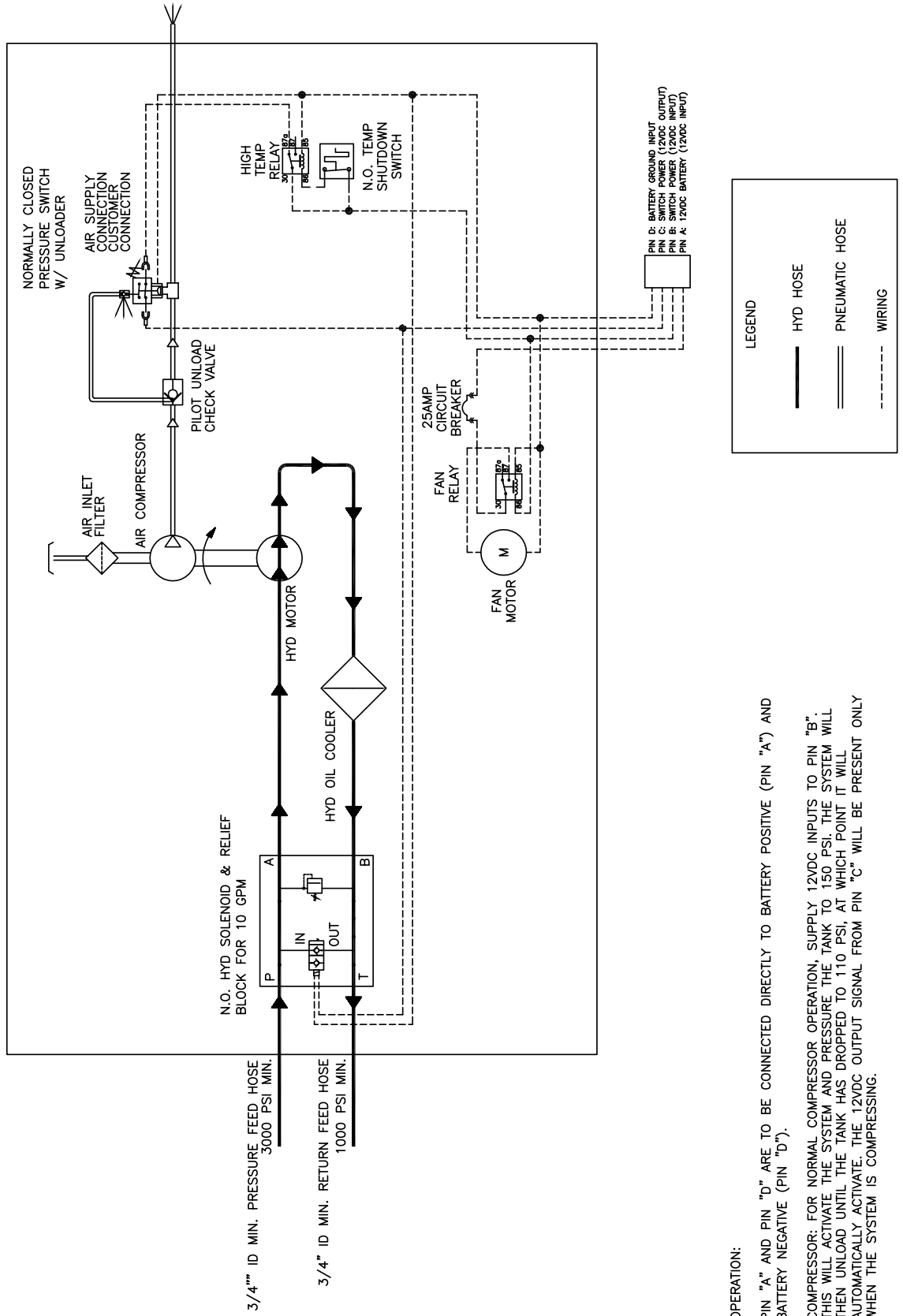

OPERATION:
PIN "A" AND PIN "D" ARE TO BE CONNECTED DIRECTLY TO BATTERY POSITIVE (PIN "A") AND BATTERY NEGATIVE (PIN "D").

COMPRESSOR: FOR NORMAL COMPRESSOR OPERATION, SUPPLY 12VDC INPUTS TO PIN "B". THIS WILL ACTIVATE THE SYSTEM AND PRESSURE THE TANK TO 150 PSI. THE SYSTEM WILL THEN UNLOAD UNTIL THE TANK HAS DROPPED TO 110 PSI, AT WHICH POINT IT WILL AUTOMATICALLY ACTIVATE. THE 12VDC OUTPUT SIGNAL FROM PIN "C" WILL BE PRESENT ONLY WHEN THE SYSTEM IS COMPRESSING.

WARRANTY SECTION



*P.O. Box 580697 * Tulsa, OK 74158-0697
4707 N. Mingo Rd. * Phone (918) 836-0463*

LIMITED WARRANTY 2 YEAR PARTS AND LABOR

Auto Crane will warranty to the consumer for a period of (2) years parts and labor from the date of purchase. Each new Auto Crane unit they sell will be free under normal use and service from defects in material and workmanship. Date of purchase will be honored as the date indicated on the Bill of Sale, which must accompany the Warranty Registration and be on file with Auto Crane. Absent a valid Warranty Registration and appropriate documentation, the original date of manufacture, as indicated by the serial number on the product, will be used to determine the effective date of the 2 year warranty.

The obligation of Auto Crane under this warranty is limited to the replacement or repair of parts that appear to the manufacturer after review and/or inspection to be defective and paid flat rate labor for replacing defective parts. This warranty does not obligate Auto Crane to bear the travel time charges in connection with the replacement or repair of defective parts. Responsibility for customer's claims arising from misapplication, abuse, misuse or alteration of equipment or parts lies with the distributor or user and no warranty obligation is assumed in these circumstances by Auto Crane.

Auto Crane will in no event be liable for any consequential damages or contingent liabilities arising out of the failure of any Auto Crane Product or parts to operate properly.

Auto Crane makes no warranty in respect to component accessories, it being subject to the warranties of their respective manufacturers.

If field service, at the request of the distributor, is rendered and fault is found not to be with Auto Crane's product, the distributor shall pay the time and expense of the field representative.

Claims for service labor or other expenses that have incurred by the buyer without approval or authorization or Auto Crane will not be accepted.

When applying for warranty, claims may be handled by contacting your nearest authorized Auto Crane Distributor. All claims are to be filed in writing on an Auto Crane Warranty Claim Form.

AUTO CRANE COMPANY IS UNDER NO OLIGATION TO EXTEND THIS WARRANTY TO ANY CUSTOMER FOR WHICH AN AUTO CRANE DELIVERY REPORT FORM HAS NOT BEEN COMPLETED AND ON FILE WITH AUTO CRANE COMPANY