

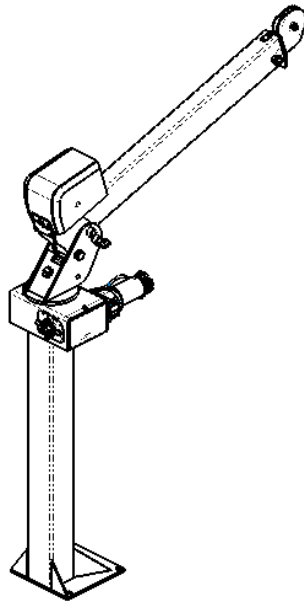

ECONO-TON III/IR OWNERS MANUAL

Manual No. 999938000

Rev. 3/15/2007



Serial No. _____

Mailing Address:
P.O. Box 580697
Tulsa, OK 74158-0697
Physical Address:
4707 N. Mingo Rd.
Tulsa, OK 74117-5904

Phone (918) 836-0463
Fax (918) 834-5979
<http://www.autocrane.com>



Auto Crane Warranty Registration

Fax Transmission

To: Warranty Department Fax: (918) 834-5979
 From: _____ Date: _____
 Re: Product Registration Pages: _____

End User Information: (Required for Warranty Activation)

Name: _____ Phone: _____
 Address: _____
 City: _____ State: _____ Zip: _____
 Contact: _____ E-mail Address: _____

Distributor Information: (Required for Warranty Activation)

Name: _____
 Address: _____
 City: _____ State: _____ Zip: _____
 Contact: _____ E-mail Address: _____

Product Information: (Required for Warranty Activation)

Model No.: _____ Serial No.: _____
 Date Product Delivered: _____ Date Processed:* _____
 VIN # _____ * For Auto Crane use only

ONE REGISTRATION FORM PER UNIT (CRANE OR BODY)

Registration form must be mailed or faxed within 15 days of customer installation.

Mail to:
 Warranty Department
 Auto Crane Company
 P.O. Box 581510
 Tulsa, OK 74158-0697

WARNINGS

WARNING! Federal law (49 cfr part 571) requires that the Final Stage Manufacturer of a vehicle certify that the vehicle complies with all applicable federal regulations. Any modifications performed on the vehicle prior to the final state are also considered intermediate stage manufacturing and must be certified as to compliance. The installer of this crane and body is considered one of the manufacturers of the vehicle. As such a manufacturer, the installer is responsible for compliance with all applicable federal and state regulations, and is required to certify that the vehicle is in compliance.

WARNING! It is the further responsibility of the installer to comply with the OSHA Truck Crane Stability Requirements as specified by 29 CFR part 1910.180 (C) (1).

WARNING! NEVER OPERATE THE CRANE NEAR ELECTRICAL POWER LINES!

Death or serious injury will result from boom, line, or load contacting electric lines. Do not use crane within 10 feet (3.05m) of electric power lines carrying up to 50,000 volts. One-foot additional clearance is required for every additional 30,000 volts or less. **SEE DANGER DECAL (P/N 040529)** in this Owner's Manual.

WARNING! NEVER.....

- ◆ **EXCEED** load chart capacities (centerline of rotation to hoist hook).
- ◆ Un-reel last 5 wraps of cable from drum!
- ◆ Wrap cable around load!
- ◆ Attempt to lift or drag a load from the side! The boom can fail far below its rated capacity.
- ◆ Weld, modify, or use unauthorized components on any Auto Crane unit! This will void any warranty or liability. Also failure of the crane may result.
- ◆ Place a chain link on the tip of the hook and try to lift a load!
- ◆ Use a sling bar or anything larger than the hook throat that could prevent the hook latch from closing, thus negating the safety feature!
- ◆ Hold on any pendant Select Switch that will cause unsafe operating conditions!

WARNING! In using a hook with latch, **ALWAYS** make sure that the hook throat is closed before lifting a load! Proper attention and common sense applied to the use of the hoist hook and various slings will prevent possible damage to material being hoisted and may prevent injury to personnel.

WARNING! Failure to correctly plumb and wire crane can cause inadvertent operation and damage to crane and/or personnel!

WARNING! Auto Crane Company remote controlled cranes are not designed or intended for use for any applications involving the lifting or moving of personnel.

WARNING! ALWAYS operate the crane in compliance with the load capacity chart. **DO NOT USE** the overload shutdown device to determine maximum rated loads, if the crane is equipped with this type of device.

READ THIS PAGE

ECONO-TON II/R

TABLE OF CONTENTS

INTRODUCTION	1-1.0
GENERAL SPECIFICATIONS	1-3.0
SAFETY TIPS AND PRECAUTIONS	2-1.0
OPERATING PRACTICES & WARNINGS	2-3.0
QUALIFICATIONS FOR OPERATORS	2-4.0
OPERATION OF UNIT/OUTRIGGERS	2-7.0
INSPECTION	3-1.0
MAINTENANCE	3-4.0
BATTERIES	3-7.0
LUBRICATION AND MAINTENANCE SCHEDULE	3-9.0
SAFETY DECAL SECTION	4-1.0
GENERAL DIMENSIONS	5-1.0
MOUNTING AND INSTALLATION	5-5.0
GENERAL ASSEMBLY	6-1.0
WINCH ASSEMBLY	6-9.0
ELECTRICAL SCHEMATIC	7-1.0
PENDANT ASSEMBLY	7-2.0
<u>ADDENDUM SECTION - ECONO-TON IIR</u>	
GENERAL DIMENSIONS	8-1.0
GENERAL ASSEMBLY	9-1.0
WINCH ASSEMBLY	9-15.0
ELECTRICAL SCHEMATIC	10-1.0
RELAY PANEL ASSEMBLY	10-2.0
RELAY HARNESS ASSEMBLY	10-3.0
PENDANT ASSEMBLY	10-5.0
LOAD CHART	11-1.0
WARRANTY	LAST PAGE

ECONO-TON II/IR INTRODUCTION

Auto Crane products are designed to provide many years of safe, trouble-free, dependable service when properly used and maintained.

To assist you in obtaining the best service from your crane and to avoid untimely crane and/or vehicle failure, this manual provides the following operating and service instructions. It is specifically recommended that all operating and service personnel consider this manual as mandatory material for reading and study before operating or servicing Auto Crane products. It is highly recommended that crane owners, equipment managers, and supervisors also read this manual.

Auto Crane has incorporated several safety features in the Econo-ton II crane for your protection.

For your convenience the overall dimensions of the Econo-ton II crane are included on the General Dimension Drawing. Rotation and turning radius are also listed on that drawing.

Remember, the crane adds weight to the vehicle. Adding weight may change the driving and riding characteristics of the vehicle unless the appropriate overload spring(s) are installed on the truck. The payload of the vehicle is reduced by the weight of the crane. The operator should exercise care when loading the vehicle. Distributing the payload on the vehicle evenly will greatly improve the driving and riding characteristics of the vehicle.

Auto Crane Company issues a limited warranty certificate with each unit sold. See last page for warranty.

The Econo-ton II cranes are attached directly to your 12 volt truck electrical system. The Econo-ton II is another highly efficient Auto Crane product. The use of a maintenance-free battery is not recommended on any Auto Crane product. The recommended alternator and battery that will give the longest life with the most useful duty cycle is a 70-amp alternator with

a 500 cold cranking amp battery. These specifications should be considered minimum.

It has always been Auto Crane Company policy to handle all warranty claims we receive as promptly as possible. If a warranty claim involves discrepant material or workmanship, Auto Crane will take immediate corrective action. It is understandable that Auto Crane Company cannot assume responsibility of liability when it is obvious that our products have been abused, misused, overloaded or otherwise damaged by inexperienced persons trying to operate the equipment without reading the manual.

Auto Crane will not assume responsibility or liability for any modifications or changes made to unit, or installation of component parts without authorization.

Auto Crane maintains a strong distributor network and a knowledgeable Customer Service Department. In most cases, an equipment problem is solved via phone conversation with our customer service department. The customer service department also has the ability to bring a local distributor, a regional sales manager, or a factory serviceman into the solution of an equipment problem.

If, through no fault of Auto Crane Company, it is necessary to send an experienced factory serviceman on a field service call the rates stated in the Auto Crane Distributor's Flat Rate Manual will apply.

Auto Crane Company's extensive Research and Development Program allow our customers to use the best equipment on the market. Our Engineering Staff and our knowledgeable sales people are always available to our customers in solving crane and winch-type application problems. When in doubt, call the Auto Crane factory.

Note: This manual should remain with the crane at all times.

ECONO-TON II/IR INTRODUCTION

DISTRIBUTOR ASSISTANCE:

Should you require any assistance not given in this manual, we recommend that you consult your nearest Auto Crane Distributor. Our distributors sell authorized parts and have service departments that can solve almost any needed repair. This manual does not cover all maintenance, operating, or repair instructions pertinent to all possible situations. **If you require additional information, please contact the Auto Crane Company at the following telephone number: (918) 836-0463.** The information contained in the manual is in effect at the time of this printing. Auto Crane Company reserves the right to update this material without notice or obligation.

NOTES

ECONO-TON II/R

GENERAL SPECIFICATIONS

DIMENSIONS

Width: (Stored)

Econo-Ton II	12.00 in (0.30 m)
Econo-Ton IIR	14.00 in (0.35 m)

Height: (Stored)

Econo-Ton II 7'	59.25 in (1.50 m)
Econo-Ton II 5'	47.75 in (1.21 m)
Econo-Ton II 7' SP*	37.75 in (0.96 m)
Econo-Ton II 5' SP*	34.25 in (0.87 m)
Econo-Ton IIR 7'	60.25 in (1.53 m)
Econo-Ton IIR 5'	48.75 in (1.24 m)
Econo-Ton IIR 7' SP*	38.75 in (0.98 m)
Econo-Ton IIR 5' SP*	35.25 in (0.90 m)

Length: (Stored)

Econo-Ton II 7'	26.05 in (0.66 m)
Econo-Ton II 5'	26.05 in (0.66 m)
Econo-Ton II 7' SP*	62.00 in (1.57 m)
Econo-Ton II 5' SP*	51.00 in (1.30 m)
Econo-Ton IIR 7'	25.00 in (0.64 m)
Econo-Ton IIR 5'	25.00 in (0.64 m)
Econo-Ton IIR 7' SP*	60.75 in (1.54 m)
Econo-Ton IIR 5' SP*	49.75 in (1.26 m)

Weight:

Econo-Ton II 7'	255 lbs (115 kg)
Econo-Ton II 5'	230 lbs (104 kg)
Econo-Ton II 7' SP*	215 lbs (98 kg)
Econo-Ton II 5' SP*	205 lbs (93 kg)
Econo-Ton IIR 7'	300 lbs (136 kg)
Econo-Ton IIR 5'	275 lbs (125 kg)
Econo-Ton IIR 7' SP*	260 lbs (118 kg)
Econo-Ton IIR 5' SP*	250 lbs (113 kg)

*Short Pedestal Option

CAPACITY

6,500 ft-lbs (0.9 ton-m)

[ft-lbs = horizontal distance from centerline of rotation to free hanging weight (feet) x amount of weight (pounds)]

LIFTING CAPACITIES

Distance	lbs
3'-3"	2,000
4'-2-1/2"	1,546
5'-2"	1,260
5'-7-3/4"	1,150
7'-1"	918

REACH

Boom will reach from 3 feet 3 inches to 5 feet 2 inches for 5' Boom.

Third boom will reach from 4 feet 2-1/2 inches to 7 feet 1 inches.

CABLE

25 ft (7.62 m) of 1/4 in (6.35 mm) diameter aircraft quality cable. This cable has a single line breaking strength of 7,000 lbs (3,175 kg).

CHASSIS REQUIREMENTS

5,200 lbs (2,359 kg) GVWR minimum

ELECTRICAL SYSTEM REQUIREMENTS

Voltage: 12 VDC

Alternator: 50 amp (minimum)

Battery: 130 minute reserve capacity (minimum)
Maintenance type

AMPERAGE DRAW/CAPACITY

LOAD		RUNNING AMPS	LIFT SPEED	
lbs.	(kgs)		ft/min	(m/min)
No Load		15	9.1	(2.77)
500	(227)	25	8	(2.44)
1000	(454)	35	7.1	(2.16)
2000	(907)	70	7.1	(2.16)

ROTATION

Econo-Ton II 348° Rotation
Econo-Ton IIR 360° Rotation

--- IMPORTANT ---

SAFETY TIPS AND PRECAUTIONS

1. No unqualified or unauthorized person shall be allowed to operate the crane.
2. **WARNING:** Never weld, modify, or use unauthorized components / parts on any Auto Crane unit. This will void any warranty or liability. Also, failure of the crane may result.
3. Make certain the vehicle meets minimum chassis requirements. (These requirements do not guarantee unit stability.)
4. Make certain the crane is installed per factory specifications. Contact your local distributor or the Auto Crane factory if any questions arise.
5. Visual inspections and tests should be conducted at the beginning of each shift each day to insure that the crane and all its operating systems are in good condition and working order before it is used.
6. Inspect hydraulic hoses frequently for signs of deterioration, and replace them as required.
7. If a hydraulic break occurs, leave the area of the break and do not attempt to stop the break by hand as the hydraulic oil may be hot and under high pressure which can cause serious injury. Shut the system down as soon as possible.
8. Check the hook at least every thirty days for distortions or cracks and replace it as required.
9. Oil gears as required.
10. Stop all operations when cleaning, adjusting or lubricating the machine.
11. Keep dirt and grit out of moving parts by keeping crane clean. Make sure machine is free of excess oil, grease, mud and rubbish, thus reducing accidents and fire hazards.
12. When a new cable is installed, operate first with a light load to let the cable adjust itself.
13. Locate the vehicle at the work site for the best stability possible.
14. Keep the vehicle in a level position while loading or unloading.
15. Observe operating area for obstructions and/or power lines that might be a hazard.
16. **WARNING: NEVER OPERATE THE CRANE NEAR ELECTRICAL POWER LINES.** Auto Crane Company recommends that the crane never be any closer to a power line (including telephone lines) than 10 feet at any point.
17. Allow the vehicle engine to warm up before operating crane.
18. Know the weight of your rigging and load to avoid overloading the crane.
19. Deduct the weight of the load handling equipment from the load rating to determine how much weight can be lifted.
20. All load ratings are based on crane capacity, NOT the vehicle stability. Remember in lifting a heavy load, the weight can create enough tipping moment to overturn the vehicle
21. Always comply with load chart capacities, (centerline of rotation to hook).
22. Secure all loads before lifting.
23. Always set the emergency brake before beginning operation.
24. Keep objects and personnel clear of crane path during operation.
25. Operate control levers slowly and smoothly in order to meter oil flow for safe operation. (Not applicable to electric-hydraulic cranes.)
26. Always extend the outriggers from vehicle to the ground before crane operation. Insure that they are firmly positioned on solid footings. Stand clear of outriggers while they are being extended.
27. If any outrigger, when extended, rests on a curb or other object that prevents it from extending to its maximum distance, shorten bearing or fulcrum point and reduce the maximum load accordingly.
28. When an outrigger will not reach the ground due to holes or grades, it shall be blocked up to provide level and firm support for the truck.
29. When working in soft earth, use wide pads under outrigger feet to prevent sinking.
30. Always store outriggers before transportation.

WARNING!

Auto Crane Company cranes are not designed or intended for use in lifting or moving persons. Any such use shall be considered to be improper and the seller shall not be responsible for any claims arising there from. This sale is made with the express understanding that there is no warranty that the goods shall be fit for the purpose of lifting or moving persons or other improper use and there is no implied warranty or responsibility for such purposes.

--- IMPORTANT ---

SAFETY TIPS AND PRECAUTIONS

31. Always store the crane in its stowed position for transportation.
32. Remember the overall height of the entire unit for garage door clearance or when moving under objects with low overhead clearance
33. Disengage power takeoff (PTO) before moving the vehicle.
(Not applicable to electric-hydraulic cranes.)
34. Always walk around the vehicle before moving.
35. Never drive with a load suspended from crane.
36. Do not take your eyes off a moving load. Look in the direction you are moving.
37. Never swing a load over people.
38. Do not stop the load sharply in midair so that it swings like a pendulum. Meter the control levers to avoid this situation.
(Not applicable to electric-hydraulic cranes.)
39. Crane boom length should be kept as short as possible for maximum lifting capacity and greater safety. Longer booms require additional care in accelerating and decelerating the swing motion, and thus slow down the working cycle and reduce productivity.
40. Keep the load directly and vertically under the boom point at all times. Crane booms are designed to handle vertical loads, not side lifts.
- WARNING:** Never attempt to lift, drag, tow or pull a load from the side. The boom can fail far below its rated capacity.
41. Do not push down on anything with boom extensions; similarly do not lift anything with boom extensions.
42. Do not lift personnel with any wire rope attachment or hook. There is no implied warranty or responsibility for such purposes.
43. **WARNING:** In using a safety hook, ALWAYS close the hook throat before lifting a load. Proper attention and common sense applied to the use of the hook and various slings will prevent possible damage to material being hoisted and may prevent injury to personnel.
44. **WARNING:** Never place a chain link on the tip of the hook and try to lift a load with the hoist.
45. **WARNING:** Never use a sling bar or anything larger than the hook throat which could prevent the safety latch from closing, thus negating the safety feature.
46. Do not wrap the wire rope around sharp objects when using winch.
47. **WARNING:** Never unreel last 5 wraps of cable from drum.

--- IMPORTANT --- OPERATING PRACTICES AND WARNINGS

1. Make certain the vehicle meets minimum chassis requirements. (These requirements do not guarantee unit stability)
2. Make certain the crane is installed per factory specifications. Contact your local Distributor or the Auto Crane factory if any questions arise.
3. Keep the vehicle in as level a position as possible while loading or unloading.
4. **ALWAYS** set the vehicle emergency brake before beginning crane operations.
5. **ALWAYS** use outriggers from vehicle to the ground during crane operation. Make sure they are firmly positioned on solid footings.
6. All load ratings are based on crane capacity, **NOT** truck/crane stability.
7. Keep objects and personnel clear of crane path during operation.
8. Keep hoist cable pulled tight at all times.
9. **REMEMBER**, in lifting a heavy load, the weight can create enough tipping momentum to overturn the vehicle.
10. **ALWAYS** keep load as close to ground as possible.
11. Hydraulic hoses need to be inspected frequently for signs of deterioration, and be replaced as required.
12. The hoist hook is an important item that an operator should consider and use properly. It should be checked on a daily basis for distortion or cracks.
13. **ALWAYS** store outriggers before road travel.
14. **WARNING! NEVER OPERATE THE CRANE NEAR ELECTRICAL POWER LINES!** Death or serious injury will result from boom, line, or load contacting electric lines. Do not use crane within 10 feet (3.05m) of electric power lines carrying up to 50,000 volts. One foot additional clearance is required for every additional 30,000 volts or less.
15. **WARNING! NEVER EXCEED** load chart capacities (centerline of rotation to hoist hook).
16. **WARNING! NEVER** un-reel last 5 wraps of cable from drum!
17. **WARNING! NEVER** wrap cable around load!
18. **WARNING! NEVER** attempt to lift or drag a load from the side! The boom can fail far below its rated capacity.
19. **WARNING! NEVER** weld, modify, or use unauthorized components on any Auto Crane unit! This will void any warranty or liability. Also failure of the crane may result.
20. **WARNING! NEVER** place a chain link on the tip of the hook and try to lift a load!
21. **WARNING! NEVER** use a sling bar or anything larger than the hook throat that could prevent the hook latch from closing, thus negating the safety feature!
22. **WARNING!** In using a hook with latch, **ALWAYS** insure that the hook throat is closed before lifting a load! Proper attention and common sense applied to the use of the hoist hook and various slings will prevent possible damage to material being hoisted and may prevent injury to personnel.
WARNING! NEVER hold any Control Select Switch on that will cause unsafe operating conditions!

WARNING!

Auto Crane Company remote controlled, stiff boom cranes are not designed or intended to be used for any applications involving the lifting or moving of personnel.

QUALIFICATIONS FOR AND CONDUCT OF OPERATORS AND OPERATING PRACTICES

REFERENCE ASME B30.5a AND OSHA 1910.180 FOR COMPLETE QUALIFICATION REQUIREMENTS

OPERATORS

1. Crane operation shall be limited to personnel with the following minimum qualifications:
 - A. Designated persons.
 - B. Trainees under the direct supervision of a designated person.
 - C. Maintenance and test personnel (when it is necessary in the performance of their duties).
 - D. Inspectors (crane).
2. No one other than the personnel specified above shall enter the operating area of a crane with the exception of persons such as oilers, supervisors, and those specified persons authorized by supervisors whose duties require them to do so and then only in the performance of their duties and with the knowledge of the operator or other persons.

QUALIFICATIONS FOR OPERATORS

1. Operators shall be required by the employer to pass a practical operating examination. Qualifications shall be limited to the specific type of equipment for which examined.
2. Operators and operator trainees shall meet the following physical qualifications:
 - A. Vision of at least 20/30 Snellen in one eye and 20/50 in the other, with or without corrective lenses.
 - B. Ability to distinguish colors, regardless of position, if color differentiation is required for operation.
 - C. Adequate hearing with or without hearing aid for the specific operation.
3. Evidence of physical defects or emotional instability, which render a hazard to operator or others, which in the opinion of the examiner could interfere with the operator's performance, may be sufficient cause for disqualification. In such cases, specialized clinical or medical judgment and tests may be required.
4. Evidence that operator is subject to seizures or loss of physical control shall be sufficient reason for disqualification. Specialized medical

tests may be required to determine these conditions.

5. Operators and operator trainees should have normal depth perception, coordination, and no tendencies to dizziness or similar undesirable characteristics.
6. In addition to the above listed requirements, the operator shall:
 - A. Demonstrate the ability to comprehend and interpret all labels, operator's manuals, safety codes, and other information pertinent to correct crane operations.
 - B. Posses the knowledge of emergency procedures and implement it.
 - C. Demonstrate to the employer the ability to operate the specific type of equipment.
 - D. Be familiar with the applicable safety regulations.
 - E. Understand the operating procedures as outlined by the manufacturer.
 - F. Be thoroughly familiar with the crane and its control functions.
 - G. Understand the operating procedures as outlined by the manufacturer.

CONDUCT OF OPERATORS

1. The operator shall not engage in any practice, which will divert his attention while actually operating the crane.
2. Each operator shall be responsible for those operations under the operator's direct control. Whenever there is any doubt as to safety, the operator shall consult with the supervisor before handling the loads.
3. The operator should not leave a suspended load unattended unless specific precautions have been instituted and are in place.
4. If there is a warning sign on the switch or engine starting controls, the operator shall not close the switch or start the engine until the warning sign has been removed by the appointed person.
5. Before closing the switch or starting the engine, the operator shall see that all controls are in the "OFF"

QUALIFICATIONS FOR AND CONDUCT OF OPERATORS AND OPERATING PRACTICES

- or neutral position and all personnel are in the clear.
6. If power fails during operation, the operator shall:
 - A. Move power controls to the "OFF" or neutral position.
 - B. Land the suspended load and boom, if practical.
 7. The operator shall be familiar with the equipment and its proper care. If adjustments or repairs are necessary, the operator shall report the same promptly to the appointed person, and shall also notify the next operator.
 8. The operator at the start of each shift shall test all controls. If any controls do not operate properly, they shall be adjusted or repaired before operations are begun.
 9. Stabilizers shall be visible to the operator while extending or setting unless a signal person assists operator.
- C. Means are provided to hold the vehicle stationary while operating the crane.
 - D. Before starting to lift, the hook shall be positioned over the load in such a manner as to minimize swinging.
 - E. During lifting care shall be taken that:
 1. There is no sudden acceleration or deceleration of the moving load.
 2. Load, boom or other parts of the crane do not contact any obstruction.
 - F. Cranes shall not be used for dragging loads sideways.
 - G. This standard recognizes that telescopic boom cranes are designed and intended for handling materials. They do not meet personnel lift or elevator requirements. Therefore, no lifting, lowering, swinging or traveling shall be done while a person is on the hook or load. Hook attached suspended work platforms (baskets) shall not be used with cranes covered by this standard. Crane manufacturer must approve work platforms attached to the boom.
 - H. The operator should avoid carrying loads over people.
 - I. When the crane is so equipped, the stabilizers shall be fully extended and set. Blocking under stabilizers shall meet the requirements as follows:
 1. Strong enough to prevent crushing.
 2. Of such thickness, width and length as to completely support the stabilizer pad.
 - J. Firm footing under all tires, or individual stabilizer pads should be level. Where such a footing is not otherwise supplied, timbers, cribbing, or other structural members to distribute the load so as to not exceed allowable bearing capacity or the underlying material should provide it.
 - K. In transit, the boom shall be carried in stowed position.
 - L. When rotating the crane, sudden starts and stops shall be avoided. Rotational speed shall be such that the load does not swing out beyond the radius at which it can be controlled.
 - M. The crane shall not be transported with a load on the hook unless recommended by the manufacturer.

OPERATING PRACTICES/HANDLING THE LOAD

1. Size of load.
 - A. No crane shall be loaded beyond the rated load except for test purposes.
 - B. The load to be lifted is to be within the rated load of the crane and its existing configuration.
 - C. When loads that are not accurately known are to be lifted, the person responsible for the job shall ascertain that the weight of the load does not exceed the crane rated load at the radius at which the load is to be lifted.
2. Attaching the load.
 - A. The load shall be attached to the hook by means of slings or other devices of sufficient capacity.
 - B. Hoist rope shall not be wrapped around the load.
3. Moving the load.

The operator shall determine that:

 - A. The crane is level and, where necessary, the vehicle/carrier is blocked properly.
 - B. The load is well secured and balanced in the sling or lifting device before it is lifted more than a few inches.

QUALIFICATIONS FOR AND CONDUCT OF OPERATORS AND OPERATING PRACTICES

N. No person should be permitted to stand or pass under a suspended load.

4. Stowing procedure.

Follow the manufacturer's procedure and sequence when stowing and un-stowing the crane.

3. Caution shall be exercised when working near overhead lines, because they can move horizontally or vertically due to wind, moving the danger zone to new positions.

4. In transit with no load and boom lowered the clearance shall be specified in Table 1.

5. A qualified signalperson shall be assigned to observe the clearance and give warning before approaching the above limits.

MISCELLANEOUS

OPERATING NEAR ELECTRICAL POWER LINES

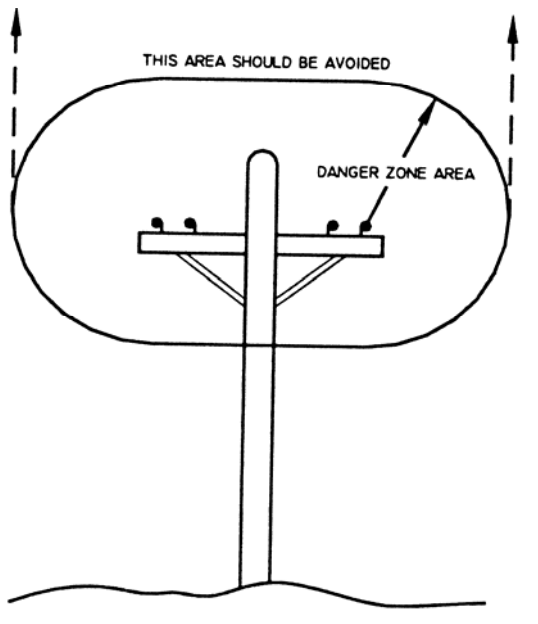

1. Cranes shall be operated so that no part of the crane or load enters into the danger zone shown above.

EXCEPTIONS

A. The danger zone may be entered after confirmation by an appointed person that the electrical distribution and transmission lines have been de-energized and visibly grounded at the point of work; or

B. The danger zone may be entered if insulating barriers (not a part of nor an attachment to the crane) have been erected to prevent physical contact with the lines.

2. For lines rated 50 kV or below, minimum clearance between the lines and any part of the crane or load (including handling appendages) shall be 10-ft. (3m). For higher voltages, see Table 1.

A. Any overhead wire shall be considered to be an energized line unless and until the person owning such line or the electrical utility authorities verify that it is not an energized line.

B. Exceptions to this procedure are allowed, if approved by the administrative or regulatory authority provided the alternate procedure insures equivalent protection and is set forth in writing.

C. Durable signs shall be installed at the operator's station and on the outside of the crane, warning that electrocution or serious bodily injury may occur unless a minimum clearance of 10 ft. (3.0m) between the crane or the load being handled and energized power lines. Greater clearances are required because of higher voltage as stated above. These signs shall be revised but not removed when local jurisdiction requires greater clearances.

TABLE 1

normal voltage, kV (phase to phase)		minimum required clearance	
		ft	(m)
<u>when operating near high voltage power lines</u>			
over	to 50	10	(3.50)
over	50 to 200	15	(4.6)
over	200 to 350	20	(6.1)
over	350 to 500	25	(7.62)
over	500 to 750	35	(10.67)
over	750 to 1000	45	(13.72)
<u>while in transit with no load and boom lowered</u>			
over	to 0.75	4	(1.22)
over	0.75 to 50	6	(1.83)
over	50 to 345	10	(3.83)
over	345 to 750	16	(4.87)
over	750 to 1000	20	(6.1)

--- IMPORTANT --- OPERATION OF UNIT

1. Make sure this manual has been thoroughly read by all crane operating personnel and supervisors.
2. A routine inspection of the crane should be mandatory before each operating day. Any defects should be corrected immediately.
3. At a job site the vehicle should be positioned so that the crane can adequately reach the load within the rated capacity (centerline of rotation to hoist hook).
4. Keep the vehicle as level as possible during operation.
5. For electric cranes, **engage emergency brake** and leave ignition on with transmission in neutral (or in park for automatic transmissions). Activate any crane power switches. For Auto Crane units requiring battery and hydraulic operation, **engage emergency brake**, place gear selector in neutral, press clutch, activate PTO, release clutch and after hydraulic fluid is warm, set throttle control to proper engine speed.
6. Always use outriggers from the truck to the ground. Be sure these are firm and adequately positioned. When rotating, **keep load as low to the ground as possible**.
7. Remove the transmitter from cab or storage area. Power transmitter on. Detach hook from dead man. Crane is now ready for operation.
8. Always boom up before rotating so the boom will clear the required boom support.
9. When extending the boom, always maintain clearance between the boom crown and the traveling block or hoist hook.
10. Always observe safe and practical operation to avoid possible accidents. Refer to Safety Tips and Precautions.
11. After completing lifting operations, return the boom to stowed position on the boom support. Avoid unneeded pressure on the boom support.
12. Store transmitter in proper location (in cab or storage area).
13. Return outriggers to stowed position. Make sure they are pinned in place or jacklegs are returned to compartment.
14. Check work area for any tools or equipment not stored.
15. Release throttle control, depress clutch and disengage PTO. Deactivate any crane power switches.
16. Report any unusual occurrence during crane operation that may indicate required maintenance or repair.
17. **NEVER** use two cranes to support a load too large for either crane.

OPERATION OF OUTRIGGERS

HYDRAULIC OUTRIGGERS

1. Shift crane/outrigger control valve to "outrigger" position.
2. Operate the outrigger control valves to position the outriggers.
3. After outriggers are positioned, return crane/outrigger selector to "crane" position.
4. Crane is now ready to operate.

MANUAL OUTRIGGERS

1. Pull lock pins to release jackleg or drop down outrigger and move to outermost lock position.
2. Make sure lock pins are reinstalled properly.
3. Lower outrigger pad to firm ground and adjust foot to take out slack.
4. Crane is now ready to operate.

INSPECTION REQUIREMENTS

REFERENCE ASME B30.5a AND OSHA 1910.180 FOR COMPLETE INSPECTION REQUIREMENTS

INSPECTION CLASSIFICATION

1. Initial inspection.

Prior to initial use, all new, altered, modified or extensively repaired cranes shall be inspected by a designated person to insure compliance with provisions of this standard.

2. Regular inspection.

Inspection procedure for cranes in regular service is divided into two general classifications based upon the intervals at which inspection should be performed. The intervals in turn are dependent upon the nature of the components of the crane and the degree of their exposure to wear, deterioration, or malfunction. The two general classifications are herein designated as "frequent" and "periodic" with respective intervals between inspections as defined below.

- A. Frequent inspection - daily or before each use
- B. Periodic inspection - one to twelve-month intervals or as specifically recommended by the manufacturer or qualified person.

**DESIGNATED PERSONNEL SHALL
PERFORM INSPECTIONS ONLY.**

FREQUENT INSPECTION

Inspections should also occur during operation for any deficiencies that might appear between regular inspections. Any deficiencies, such as those listed below, shall be carefully examined and a determination made as to whether they constitute a hazard:

1. Inspect control mechanisms for maladjustment that interferes with proper operation.
2. Inspect control mechanisms for excessive wear of components and contamination by lubricants or other foreign matter.

3. Inspect safety devices for malfunction.
4. Visually inspect all hydraulic hoses, particularly those that flex in normal operation of crane functions.
5. Inspect hooks and latches for deformation, chemical damage, cracks, and wear. Refer to ANSI/ASME B30.10.
6. Inspect for proper rope reeving.
7. Inspect electrical wiring and components for malfunctioning, signs of excessive deterioration, dirt and moisture accumulation.
8. Inspect hydraulic system for proper oil level and leaks.
9. Inspect tires for recommended inflation pressure, cuts and loose wheel nuts.
10. Inspect connecting pins and locking device for wear damage and loose retaining bolts.
11. Inspect rope for gross damage, such as listed below, which may be an immediate hazard.
 - A. Distortion such as kinking, crushing, unstranding, birdcaging, main strand displacement, or core protrusion. Loss of rope diameter in a short length or unevenness of outer strands should be replaced.
 - B. General corrosion.
 - C. Broken or cut strands.
 - D. Use care when inspecting sections of rapid deterioration around flange points, crossover points, and repetitive pickup points on drums.
 - E. Inspect number, distribution, and type of visible broken wires. Reference Rope Maintenance section in the owner's manual.

Continued use of rope depends upon good judgment by a designated person in evaluating remaining strength in a used rope after allowance for deterioration disclosed by inspection. Continued rope operation depends upon this remaining strength.

INSPECTION REQUIREMENTS

PERIODIC INSPECTION

Any deficiencies, such as those listed below, shall be carefully examined and determination made as to whether they constitute a hazard:

1. Inspect for deformed, cracked or corroded members in the crane structure and entire boom.
2. Inspect for loose bolts, particularly mounting bolts.
3. Inspect for cracked or worn sheaves and drums.
4. Inspect for worn, cracked, or distorted parts such as pins, bearings, shafts, gears, rollers and devices.
5. Inspect for excessive wear on brake and clutch system parts and lining.
6. Inspect crane hooks for cracks.
7. Inspect travel steering, braking, and locking devices for malfunction.
8. Inspect for excessively worn or damaged tires.
9. Inspect hydraulic hose, fittings, and tubing for the following problems:
 - A. Evidence of leakage at the surface of the flexible hose or its junction with metal and coupling.
 - B. Blistering, or abnormal deformation to the outer covering of the hydraulic or pneumatic hose.
 - C. Leakage at threaded or clamped joints that cannot be eliminated by normal tightening or recommended procedures.
 - D. Evidence of excessive abrasion or scrubbing on the outer surface of a hose, rigid tube, or fitting. Means shall be taken to eliminate the interference of elements in contact or otherwise protect the components.
10. Inspect hydraulic pumps and motors for the following problems:
 - A. Loose bolts and fasteners.
 - B. Leaks at joints between sections.
 - C. Shaft seal leaks.
 - D. Unusual noises or vibrations.
 - E. Loss of operating speed.
 - F. Excessive heating of the fluid.
 - G. Loss of pressure.
11. Inspect hydraulic valves for the following problems:
 - A. Cracks in valve housing.
 - B. Improper return of spool to neutral position.
 - C. Leaks at spools or joints.
 - D. Sticking spools.
 - E. Failure of relief valves to attain or maintain correct pressure setting.
 - F. Relief valve pressure shall be checked as specified by the manufacturers.
12. Inspect hydraulic cylinders for the following problems:
 - A. Drifting caused by fluid leaking across piston.
 - B. Rod seals leaking.
 - C. Leaks at welding joints.
 - D. Scored, nicked, or dented cylinder rods.
 - E. Damaged case (barrel).
 - F. Loose or deformed rod eyes or connecting joints.
13. Inspect hydraulic filters for evidence of rubber particles on the filter elements indicating possible hose, "O" ring, or other rubber component deterioration. Metal chips or pieces on the filter may denote failure in pumps, motors, or cylinders. Further inspection will be necessary to determine the origin of the problem before corrective action can be taken.
14. Inspect labels to confirm correct location and legibility. Reference decal layout in this manual for proper location of decals.
15. **Rope Inspections need not be at equal calendar intervals and should be more frequent as the rope approaches the end of useful life.** A qualified person shall inspect the wire rope based on such factors as:
 - A. Expected rope life as determined by experience on the particular installation or similar installations.
 - B. Severity of environment.
 - C. Percentage of capacity lifts.
 - D. Frequency rates of operation.
 - E. Exposure to shock loads.This inspection shall cover the entire length of the rope. Only the surface wires need to be inspected and no attempt should be made to open the rope. Any deterioration resulting in appreciable loss of original strength shall be noted and determination made as to whether use of the rope would constitute a hazard. A few notable deterioration points are listed below:

INSPECTION REQUIREMENTS

- A. Reduction of rope diameter below nominal diameter due to loss of core support.
- B. Internal or external corrosion.
- C. Wear of outside wires.
- D. Severely corroded, cracked, bent, worn, or improperly applied connections.

CRANES NOT IN REGULAR USE

A crane, which has been idle for a period of over one month or more, shall be given an inspection conforming to the "initial" and "regular" inspection requirements of this section.

INSPECTION RECORDS

Dated records of periodic inspection should be made on critical items such as brakes, crane hooks, rope, cylinders, and relief pressure valves.

NOTES

TESTING REQUIREMENTS

REFERENCE ASME B30.5a AND OSHA 1910.180 FOR COMPLETE TESTING REQUIREMENTS

TESTING SHALL BE PERFORMED BY DESIGNATED PERSONNEL ONLY.

Prior to initial use, all new, altered, modified, or extensively repaired cranes shall be tested for compliance with the operational requirements of this crane.

Test requirements:

1. Test all functions to verify speed and operation.
2. Check that all safety devices are working properly.
3. Confirm operating controls comply with appropriate function labels.
4. Test loads shall not exceed 110% of the manufacturer's load rating.
5. Written reports shall be maintained showing test procedures and confirming the adequacy of repairs.

GENERAL REPAIRS AND MAINTENANCE

REFERENCE ASME B30.5a AND OSHA 1910.180 FOR COMPLETE MAINTENANCE AND REPAIR REQUIREMENTS

A preventative maintenance program should be established based on this section and all replacement parts should be obtained from AutoCrane Company.

For replacement parts contact your local authorized distributor.

MAINTENANCE PRECAUTIONS

1. Place crane where it will cause the least interference with other equipment or operations.
2. Verify all controls are in the "off" position and all operating features secured from inadvertent motion by brakes, pawls, or other means.
3. The means for starting the crane shall be rendered inoperative.
4. The boom should be secured in place before maintenance.
5. Relieve hydraulic oil pressure from all hydraulic circuits before loosening or removing hydraulic components.
6. Warning or "OUT OF ORDER" signs shall be placed on all crane controls.
7. After adjustments and repairs have been made, the crane shall not be returned to service until all guards have been reinstalled, trapped air removed from hydraulic system (if required), safety devices reactivated, and maintenance equipment removed.

ADJUSTMENTS AND REPAIRS

1. Any hazardous conditions disclosed by the inspection requirements shall be corrected before operation of crane is resumed. Only designated personnel shall do adjustments and repairs.
2. Adjustments shall be maintained to assure correct functioning of components, the following are examples:
 - A. Functional operating mechanism.
 - B. Safety devices.
 - C. Control systems.
3. Repairs or replacements shall be provided as needed for operation, the following are examples:
 - A. Critical parts of functional operating mechanisms which are cracked, broken, corroded, bent, or excessively worn.

- B. Critical parts of the crane structure which are cracked, bent, broken, or excessively corroded.
 - C. Crane hooks showing cracks, damage, or corrosion shall be taken out of service. Repairs by welding are not recommended.
4. If bleeding the hydraulic system is required, run each crane function until smooth operation of that particular function is noticeable.

LUBRICATION

All moving parts of the crane, for which lubrication is specified, should be regularly lubricated per the manufacturer's recommendations and procedures. **Reference Lubrication and Maintenance Schedule in this manual.**

ROPE REPLACEMENT

No precise rules can be given for determination of the exact time for replacement of rope, since many variable factors are involved.

1. Conditions such as the following shall be reason for questioning continued use of the rope or increasing the frequency of inspection:
 - A. In running ropes, six randomly distributed broken wires in one lay or three broken wires in one strand in one lay.
 - B. One outer wire broken at the contact point with the core of the rope structure and protrudes or loops out of the rope structure. Additional inspection of this section is required.
 - C. Wear of one third of the original diameter of the outside individual wire.
 - D. Kinking, crushing, bird caging, or any other damage resulting in distortion of the rope structure.
 - E. Evidence of any heat damage from any cause.
 - F. Reduction from nominal diameter of more than 1/64 in. (0.4mm) for diameters up to and including 5/16 in. (8 mm), 1/32 in. (0.8 mm) for diameter 3/8 in. (9.5 mm) to and including 1/2 in. (13 mm), 3/64 in. (1.2 mm) for diameter 9/16 in. (14.5 mm) to and including 3/4 in. (19 mm), 1/16 in. (1.6 mm) for diameter 7/8 in. (22 mm) to and including 1 1/8 in. (29 mm), 3/32 in.

GENERAL REPAIRS AND MAINTENANCE

(2.4 mm) for diameters 1 1/4 in. (32 mm) to and including 1 1/2 in. (38 mm).

- G. In standing ropes, more than two broken wires in one lay in sections beyond end connections or more than one broken wire at an end connection.
- 2. Replacement rope shall have a strength rating at least as great as the original rope furnished or recommended by AutoCrane. A rope manufacturer, AutoCrane, or a qualified person shall specify any deviation from the original size, grade, or construction.

ROPE MAINTENANCE

1. Rope should be stored to prevent damage or deterioration.
2. Unreeling or uncoiling of rope shall be done as recommended by the rope manufacturer and with care to avoid kinking or inducing twist.
3. Before cutting a rope, seizing shall be placed on each side of the place where the rope is to be cut to prevent unlaying of the strands. On pre-formed rope, one seizing on each side of the cut is required. On non-preformed ropes of 7/8 in. (22 mm) diameter or smaller, two seizings on each side of the cut are required, and for non-preformed rope 1 in. (25 mm) diameter or larger, three seizings on each side of the cut are required.
4. During installation care should be exercised to avoid dragging of the rope in the dirt or around objects that will scrape, nick crush or induce sharp bends in it.
5. Rope should be maintained in a well-lubricated condition. It is important that lubricant applied as a part of a maintenance program shall be compatible with the original lubricant and to this end the rope manufacturer should be consulted. Lubricant applied shall be the type that does not hinder visual inspection. Those sections of rope that are located over sheaves or otherwise hidden during inspection and maintenance procedures require special attention when lubricating rope. The object of rope lubrication is to reduce internal friction and to prevent corrosion.
6. When an operating rope shows greater wear or well-defined localized areas than on the remainder of the rope, rope life can be extended in some cases by shifting the wear to different areas of the rope.

MAINTENANCE OF BATTERIES

Maintenance of Auto Crane unit batteries differs very little from the generally prescribed maintenance of any lead acid battery. All batteries must be kept properly charged, properly filled with water, and relatively clean.

Keep Properly Charged

Many things affect the proper charge to a battery, such as:

1. Regulator settings.
2. Proper tightness of belts on the alternator or generator.
3. Good, clean connections of all cables and wires at the following places:
 - a. Battery.
 - b. Regulator.
 - c. Starting motor.
 - d. Alternator or generator.
 - e. Ground connections (most important).

It is of extreme importance to keep the battery as fully charged as possible without overcharging, especially when vehicles are left outside for extended periods in extremely cold climates. A battery can freeze. Freezing points for various specific gravities of acid are as follows:

Specific Gravity (Corrected to 80°F)	Freezing Temp. Degrees F.
1.280	-90°F
1.250	-62°F
1.200	-16°F
1.150	5°F
1.100	19°F

As shown, a half-charged battery (about 1.100 specific gravity) cannot stand for any length of time at 20°F or it will freeze.

The main reason for keeping the battery as fully charged as possible without over-charging is to insure that power is available even though the vehicle has been standing for some time.

Keep Properly Filled with Water

The battery should *always* be properly filled with water. If the electrolyte level is allowed to fall below the top of the plates, the results become threefold:

1. The exposed portion of the plate will become sulfated.
2. The portion of the plate exposed is not usable.
3. That portion of the acid remaining becomes more concentrated and may cause more rapid

deterioration of the remaining parts of the battery.

Keep A Relatively Clean Battery

The battery should be kept clean. Batteries filled with acid and which are not in use self-discharge to a limited degree because of the nature of the materials within the battery. If dirt is allowed to collect on the top of the battery (and this dirt absorbs moisture) and electrical path can be set up between the various terminals of the battery and the ground. Once such a path has been established, the self-discharge of the battery is accelerated. This also accelerates corrosion of the battery cables at the terminals.

Periodic Maintenance is Needed

A definite program of periodic maintenance of all batteries should be conducted on a regular basis. Periodic maintenance includes:

1. Checking belts for tightness on the charging equipment.
2. Checking battery electrolyte levels.
3. Checking cables for good connections.
4. Cleaning where corrosion is apparent.

When corrosion is cleaned off, the cable terminals and battery terminals should be coated with a light coating of petroleum jelly before they are replaced. When terminals are cleaned, the top of the battery should be cleaned with a mild solution of soda water.

Low Maintenance Batteries (Maintenance Free)

Low maintenance batteries should not be used on AutoCrane Cranes or trucks equipped with AutoCrane Cranes. The batteries are not designed for "deep" discharge.

Testing Your Battery

If the condition of the battery is in question, it should be removed from the vehicle, taken to the shop, and allowed to reach room temperature. It should then be recharged until specific gravity readings taken at one-half hour intervals. If the specific gravity readings are fairly uniform, the battery should be checked with a high rate tester. Use the tester in accordance with the manufacturer's instructions. The high rate tester is the best method to test a questionable battery.

MAINTENANCE OF BATTERIES

If, after charging, it is noted that the specific gravity reading of one cell is 30 points less than any of the other cells, it may be assumed that the cell is bad and that the battery should be replaced. If all cells are uniform but not up to full charge, a low rate of charge should be attempted for an extended time. This usually will recover a badly sulfated battery.

Replacing a Battery

If it is necessary to replace a battery, and a dry charge battery is used, the following procedure applies:

1. Fill the battery with electrolyte of the proper specific gravity.

2. Place the battery on charge according to the manufacturer's instructions.

It is essential that the second step above be followed to ensure that the battery going on the vehicle is fully charged.

It is also very important that the battery hold-downs be checked periodically to insure that the batteries are properly positioned to avoid vibration problems, breakage of cables or terminals. Care must be taken to avoid cracking or breaking containers or covers by tightening hold-down fixtures excessively. They also must not be so loose that breakage results from a hold-down that is too loose.

ECONO-TON II/IIR

LUBRICATION & MAINTENANCE SCHEDULE

SERVICE PERFORMED	DAY	WEEKLY	MONTH	YEAR	NOTES
LOAD HOOK	X				INSPECT HOOK & LATCH FOR DEFORMATION, CRACKS, & CORROSION
CABLE DRUM	X				MAKE SHURE CABLE IS WOUND EVENLY ON DRUM
HOIST CABLE	X				CHECK FOR FLATTENING, KINKS, & BROKEN STRANDS, SEE MANUAL
MOUNTING BOLTS		X			CHECK-TORQUE TO128 FT-LBS (DRY) AS REQUIRED
MOTOR CONNECTION		X			CHECK TERMINALS FOR TIGHT CONNECTIONS
SHEAVE BEARINGS		X			SEALED BEARING, REPLACE IF ROUGH OR LOOSE
ALL OTHER BOLTS		X			CHECK-TIGHTEN AS REQUIRED
BATTERY CONNECTIONS		X			CHECK FOR CORROSION & TIGHT CONNECTIONS. CLEAN & COAT AS REQUIRED.
POWER CABLE			X		CHECK INSULATION FOR DAMAGE OR DETERIORATION
ROTATION GEAR			X		WATER PROOF BEARING GREASE OR DRY MOLYLUBE IF DUSTY
FOR ADDITIONAL INFORMATION SEE: 1) OWNER'S MANUAL 2) OSHA SECTION 1910.180 3) ANSI B30.5-1989					

CAUTION: Routine maintenance insures trouble-free operation and protects your investment. All warranties are void if maintenance is neglected.

NOTES:

1. Use only authorized parts. Any damage or malfunction caused by the use of unauthorized parts is not covered by Warranty or Product Liability
2. Once a bolt has been torqued to its rated capacity and then removed; the bolt should be replaced with a new one.
3. Auto Crane Company recommends that this crane be serviced per "Crane Inspection Log" P/N 999978. These logs should be filled in at the intervals noted and kept as a permanent record. Additional copies are available from your local distributor.

ECONO-TON II/IIR MAINTENANCE

LUBRICATION OF THE ECONO-TON II

Most bearings on the winch are factory sealed and cannot be greased. Lube winch gear once a month.

The only other place to lube this crane is at the bushings in the base (P/N: 272406) of this unit. Wipe a small amount of grease (bearing type) on the bushings or stem that fits into these bushings once a month, depending on use, maybe more often.

For the Econo-Ton IIR, you will need to grease the rotation worm gear bearing every 6 months. To apply, simply use grease fittings on the end of the worm gear.

BRAKE ADJUSTMENT - WINCH

The brake on this unit consists of two springs with pads on the ends (P/N: 272434), which rub the brake disc (P/N: 272433) on the end of the shaft coming out of the motor. This drum works free one way. Then you hoist down, it works to hold the speed and load. There is no real adjustment of this brake. If you try to bend the springs too much, they will break. These winches come with the brake already installed.

CHANGE CABLE

To change cable, hoist down to the end of the old cable on the drum. There is a small carriage bolt and clamp; loosen the bolt in the clamp to remove the cable. Replace with a new cable passed underneath the clamp. Tighten the bolt securely and re-spool the cable on the drum; maintain a light tension on the cable so the cable will spool properly.

CAUTION: FOR BRAKE TO OPERATE CORRECTLY, THE CABLE MUST BE WRAPPED SO THAT THE REMAINING CABLE COMES FROM THE BOTTOM OF THE DRUM.

LOWER QUILL BEARING

If lower quill bearing (P/N: 370033) is to be replaced, press until existing bearing drops to the pedestal. Press new bearing in until the edge of the bearing is even with the machined edge in the pedestal quill.

ECONO-TON II/R

SAFETY DECAL SECTION

PART NO.: 040579000
 DECAL: OPERATING INSTRUCTIONS
 FUNCTION: To inform the operator of the proper procedure to follow for safe operation of the crane.
 USED ON: All Cranes
 QUANTITY: 2
 PLACEMENT: Pedestal, Both Sides

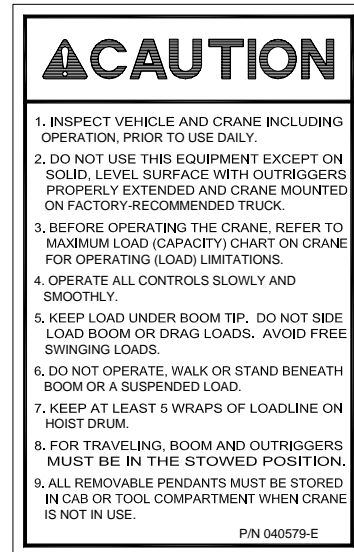

PART NO.: 040580000
 DECAL: OPERATING TRAINING
 FUNCTION: To inform the operator of the need to receive proper training before using the crane.
 USED ON: All Cranes
 QUANTITY: 2
 PLACEMENT: Pedestal, Both Sides

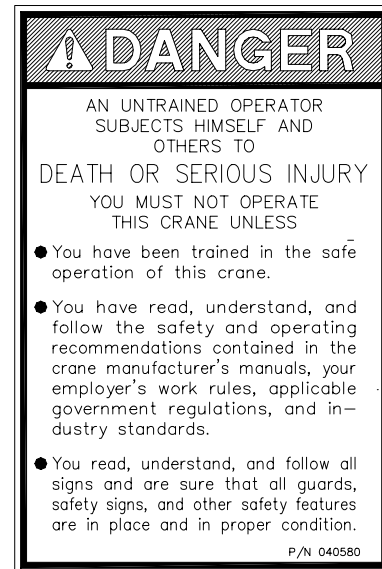

PART NO.: 040517000
 DECAL: STAY CLEAR OF BOOM
 FUNCTION: To inform the operator of the hazard of proximity or contact with the crane boom during operation.
 USED ON: All Cranes
 QUANTITY: 2
 PLACEMENT: Both sides of crown

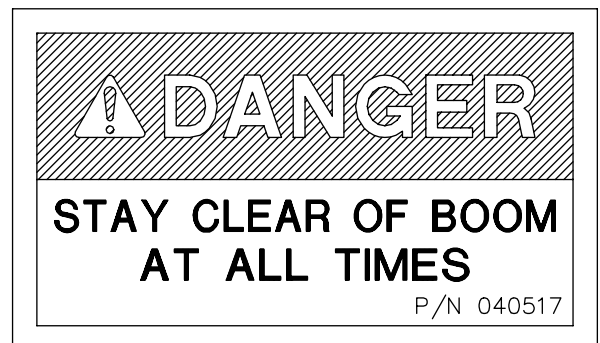

ECONO-TON II/R

SAFETY DECAL SECTION

PART NO.: 040630000
 DECAL: STAY CLEAR OF LOAD
 FUNCTION: To inform the operator of the hazard of proximity or contact with the crane load during operation.
 USED ON: All Cranes
 QUANTITY: 2
 PLACEMENT: Both sides of Crown

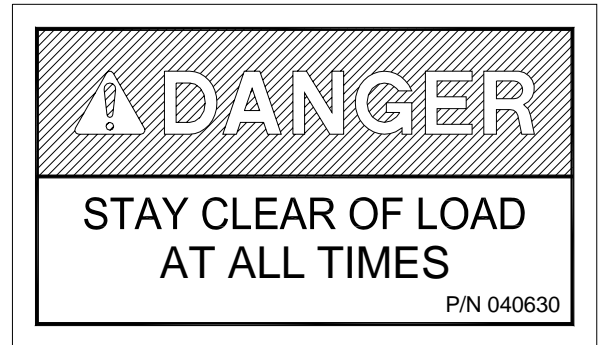

PART NO.: 370495
 DECAL: OPERATING INSTRUCTIONS
 FUNCTION: To inform the operator of the proper procedure to follow for safe operation of the crane.
 USED ON: Short Pedestal Cranes
 QUANTITY: 2
 PLACEMENT: Both Sides of Boom or Pedestal

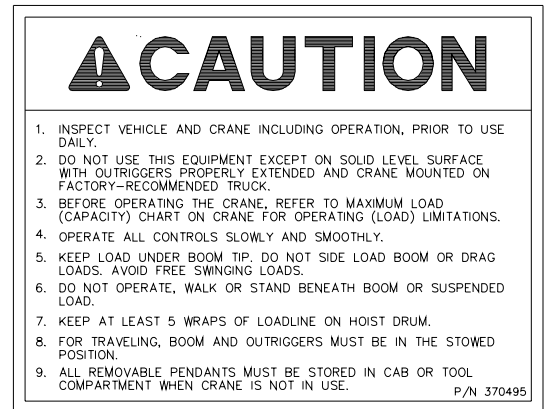

PART NO.: 370496
 DECAL: OPERATING TRAINING
 FUNCTION: To inform the operator of the need to receive proper training before using the crane.
 USED ON: Short Pedestal Cranes
 QUANTITY: 2
 PLACEMENT: Both Sides of Boom

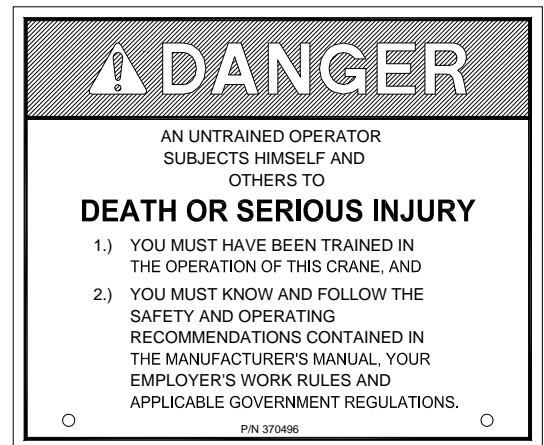

NOTES

ECONO-TON II/R

SAFETY DECAL SECTION

PART NO.: 370873040
DECAL: ROPE TENSION
FUNCTION: To inform the operator of the need to
keep tension on the rope at all times.

USED ON: All Cranes
QUANTITY: 2
PLACEMENT: Both Sides of Winch

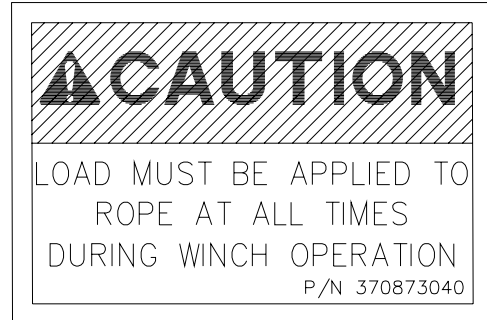

ECONO-TON II/R

DECAL KIT 7' BOOM - P/N: 370872000

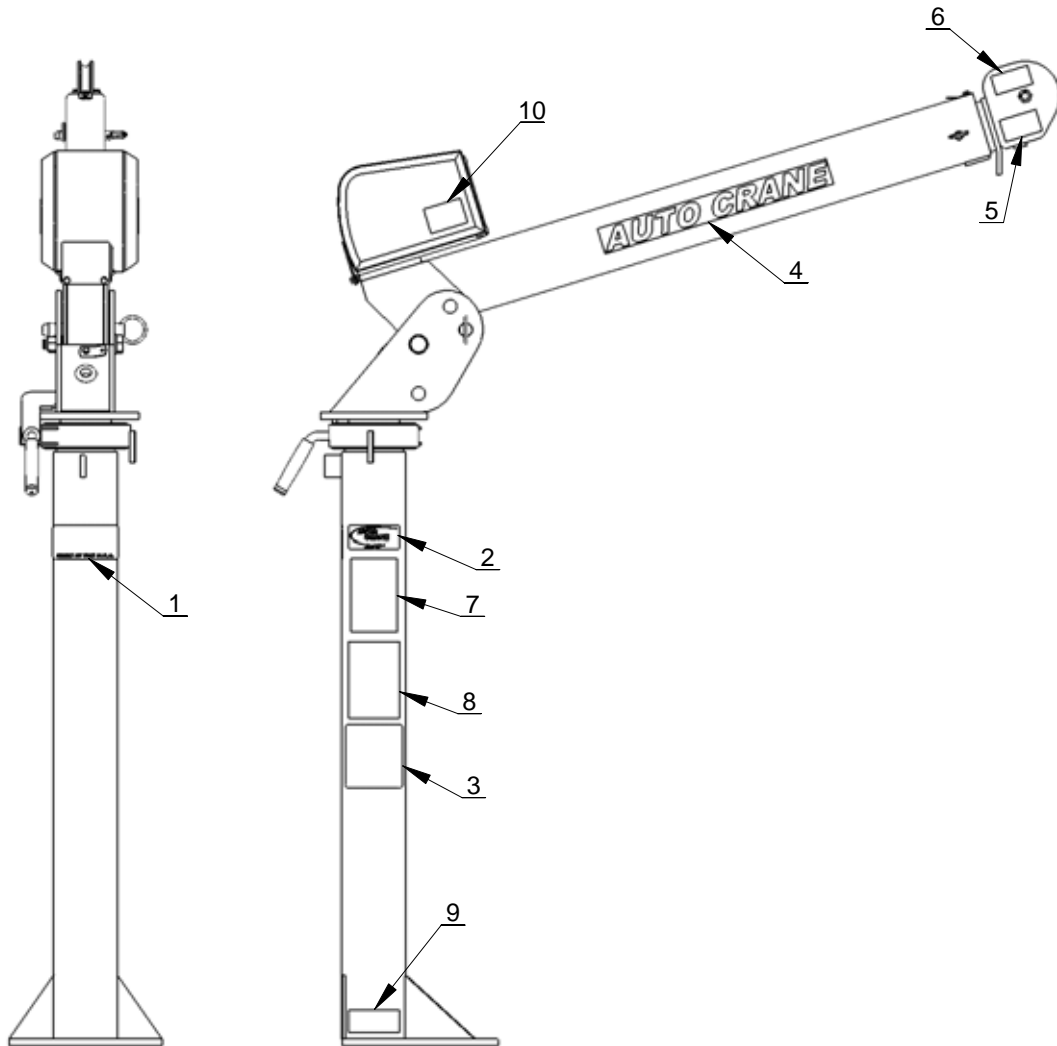

ITEM NO.	QTY.	PART NO.	DESCRIPTION
1	1	040824000	DECAL, AMERICAN FLAG, MADE IN THE U.S.A.
2	2	040619001	DECAL AUTO CRANE LOGO
3	2	370873000	DECAL, LOAD CHART 7' BOOM STD PED
4	2	600047000	DECAL AUTO CRANE
5	2	040630000	DECAL DANGER "STAY CLEAR OF LOAD"
6	2	040517000	DECAL STAY CLEAR OF BOOM
7	2	040579000	DECAL OPERATION INSTRUCTIONS
8	2	040580000	DECAL TRAINED OPERATOR
9	1	330622000	DECAL SERIAL NO
10	2	370873040	DECAL, CAUTION "ROPE TENSION"

ECONO-TON II/R

DECAL KIT 5' BOOM - P/N: 370872010

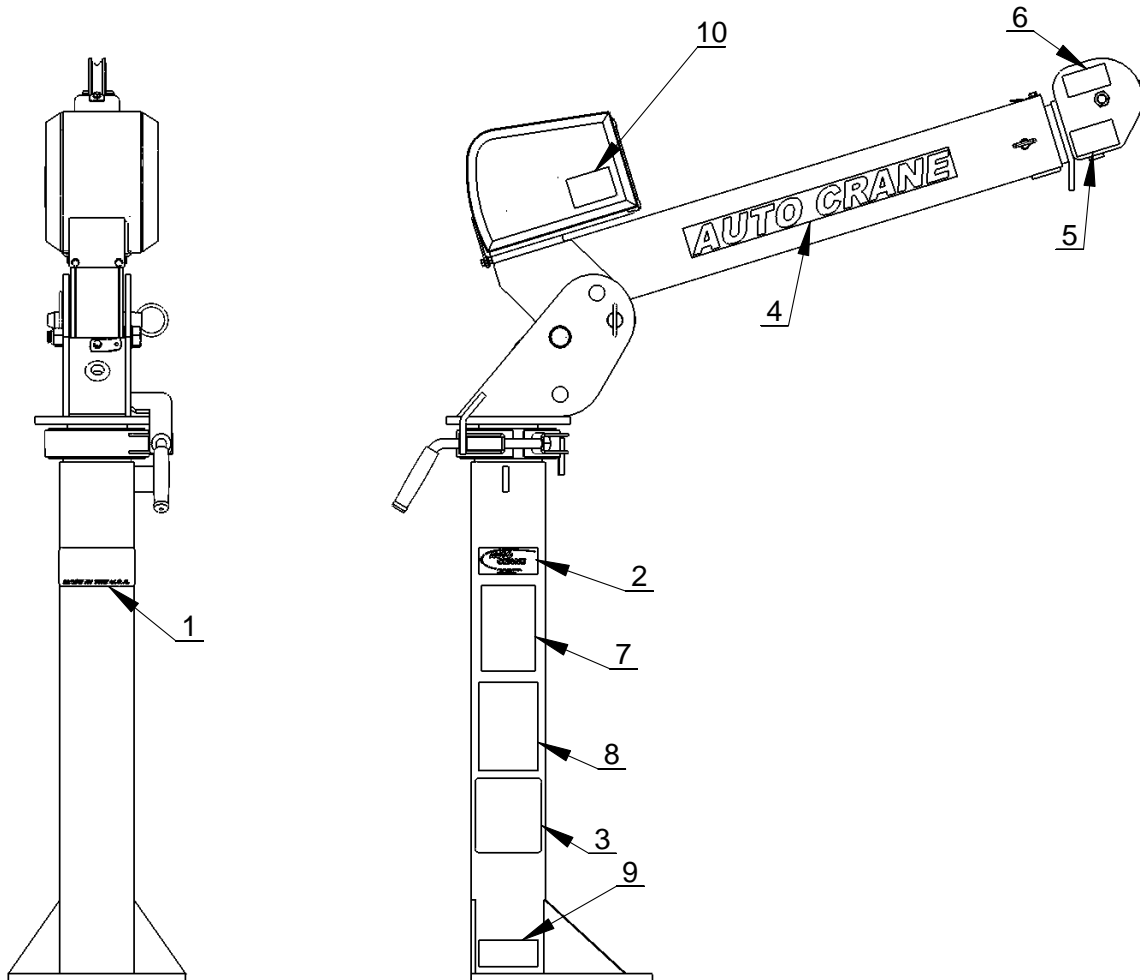

ITEM NO.	QTY.	PART NO.	DESCRIPTION
1	1	040824000	DECAL, AMERICAN FLAG, MADE IN THE U.S.A.
2	2	040619001	DECAL AUTO CRANE LOGO
3	2	370873010	DECAL, LOAD CHART 7' BOOM STD PED
4	2	600047000	DECAL AUTO CRANE
5	2	040630000	DECAL DANGER "STAY CLEAR OF LOAD"
6	2	040517000	DECAL STAY CLEAR OF BOOM
7	2	040579000	DECAL OPERATION INSTRUCTIONS
8	2	040580000	DECAL TRAINED OPERATOR
9	1	330622000	DECAL SERIAL NO

ECONO-TON II/R
DECAL KIT 7' BOOM SHORT PEDESTAL
P/N: 370872020

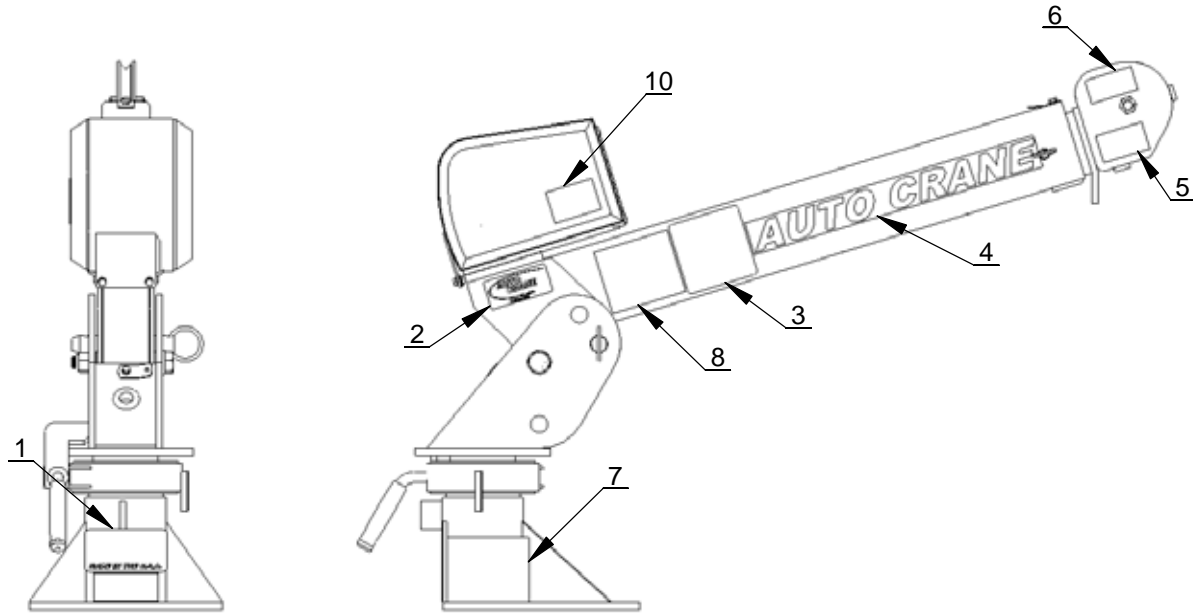

ITEM NO.	QTY.	PART NO.	DESCRIPTION
1	1	040824000	DECAL, AMERICAN FLAG, MADE IN THE U.S.A.
2	2	040619001	DECAL AUTO CRANE LOGO
3	2	370873020	DECAL, LOAD CHART 7' BOOM SHORT PED
4	2	600047000	DECAL AUTO CRANE
5	2	040630000	DECAL DANGER "STAY CLEAR OF LOAD"
6	2	040517000	DECAL STAY CLEAR OF BOOM
7	2	370495000	DECAL, CAUTION "INSPECT VEHICLE..."
8	2	370496000	DECAL, DANGER "UNTRAINED OPERATOR"
9	1	330622000	DECAL SERIAL NO
10	2	370873040	DECAL, CAUTION "ROPE TENSION"

ECONO-TON II/R
DECAL KIT 5' BOOM SHORT PEDESTAL
P/N: 370872030

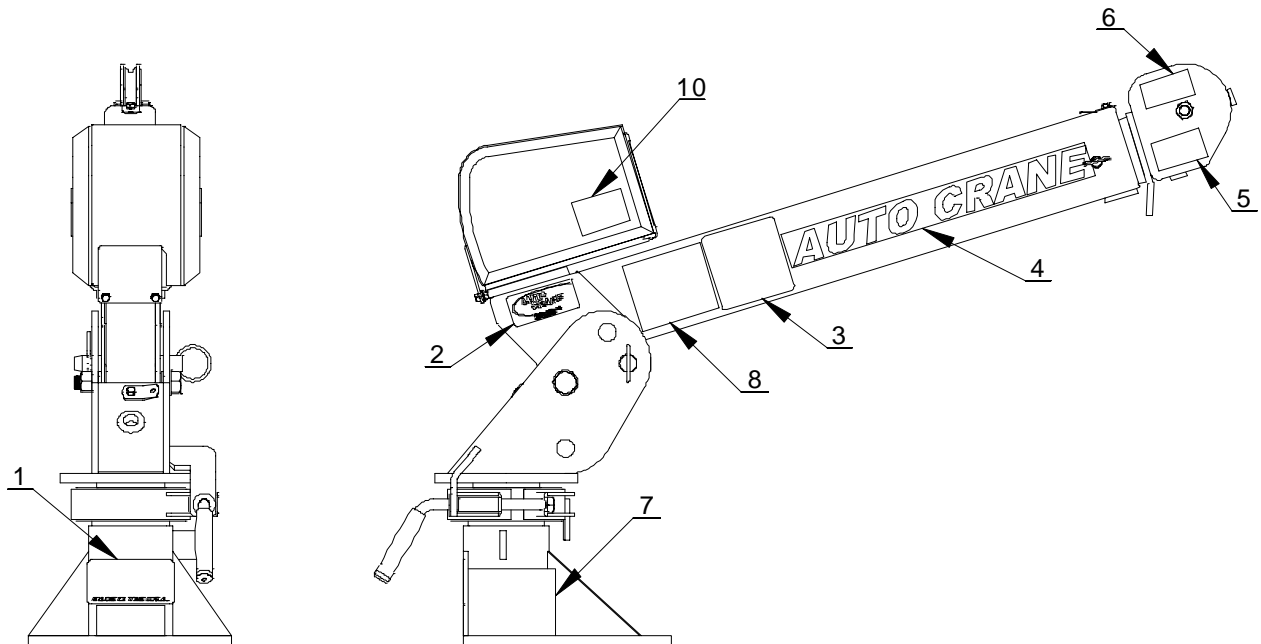

ITEM NO.	QTY.	PART NO.	DESCRIPTION
1	1	040824000	DECAL, AMERICAN FLAG, MADE IN THE U.S.A.
2	2	040619001	DECAL AUTO CRANE LOGO
3	2	370873030	DECAL, LOAD CHART 5' BOOM SHORT PED
4	2	600047000	DECAL AUTO CRANE
5	2	040630000	DECAL DANGER "STAY CLEAR OF LOAD"
6	2	040517000	DECAL STAY CLEAR OF BOOM
7	2	370495000	DECAL, CAUTION "INSPECT VEHICLE..."
8	2	370496000	DECAL, DANGER "UNTRAINED OPERATOR"
9	1	330622000	DECAL SERIAL NO
10	2	370873040	DECAL, CAUTION "ROPE TENSION"

ECONO-TON II GENERAL DIMENSIONS – 7' BOOM

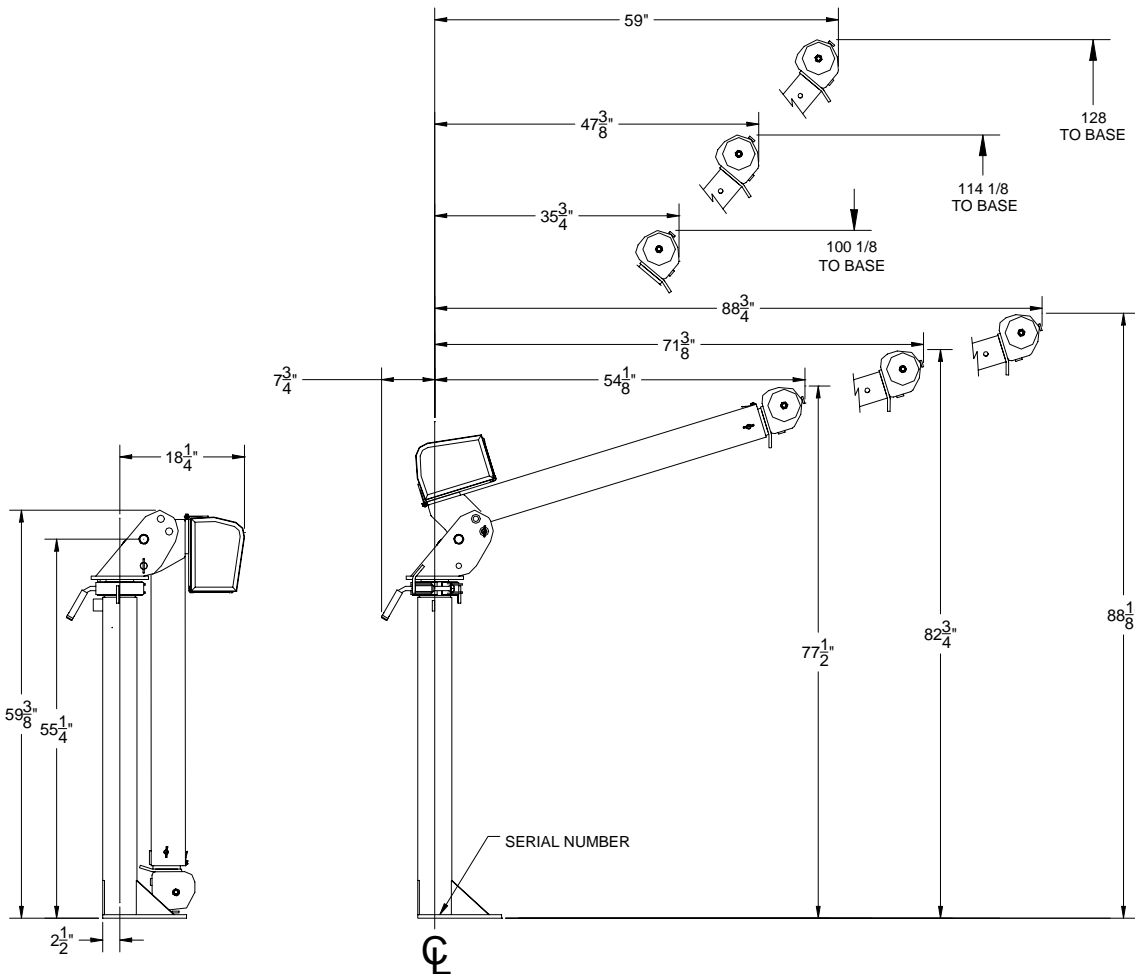
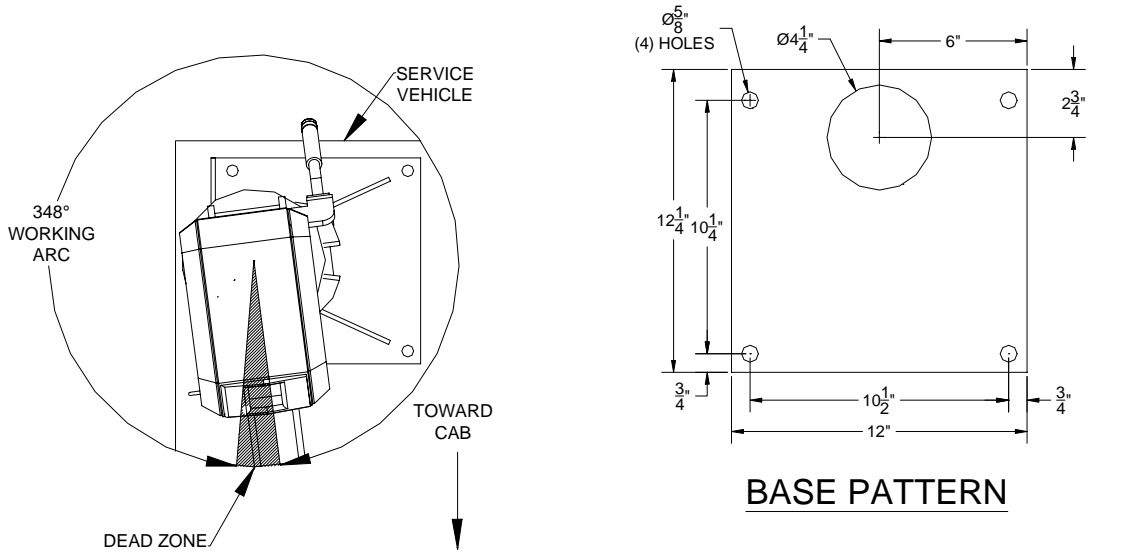

ECONO-TON II

GENERAL DIMENSIONS – 5' BOOM

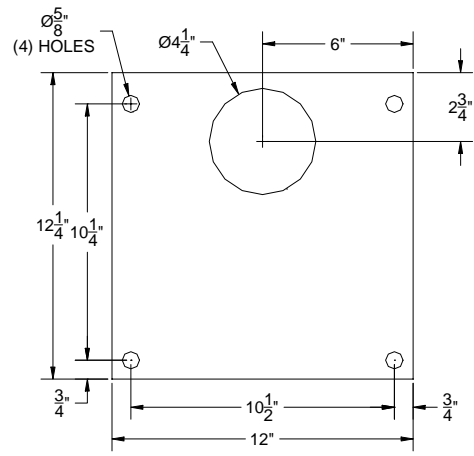
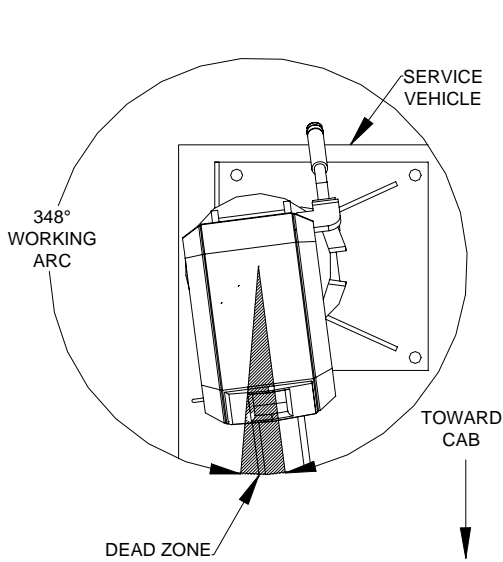

BASE PATTERN

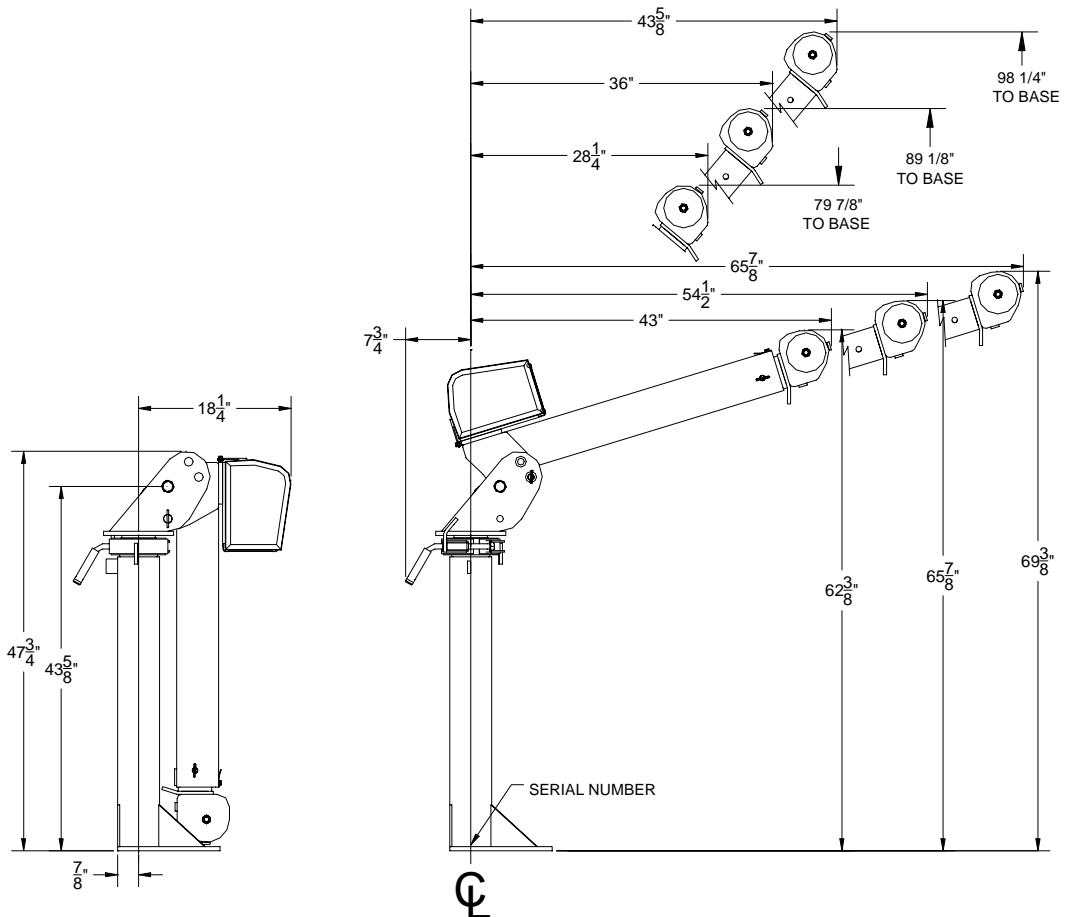

ECONO-TON II

GENERAL DIMENSIONS 7' BOOM SHORT PEDESTAL

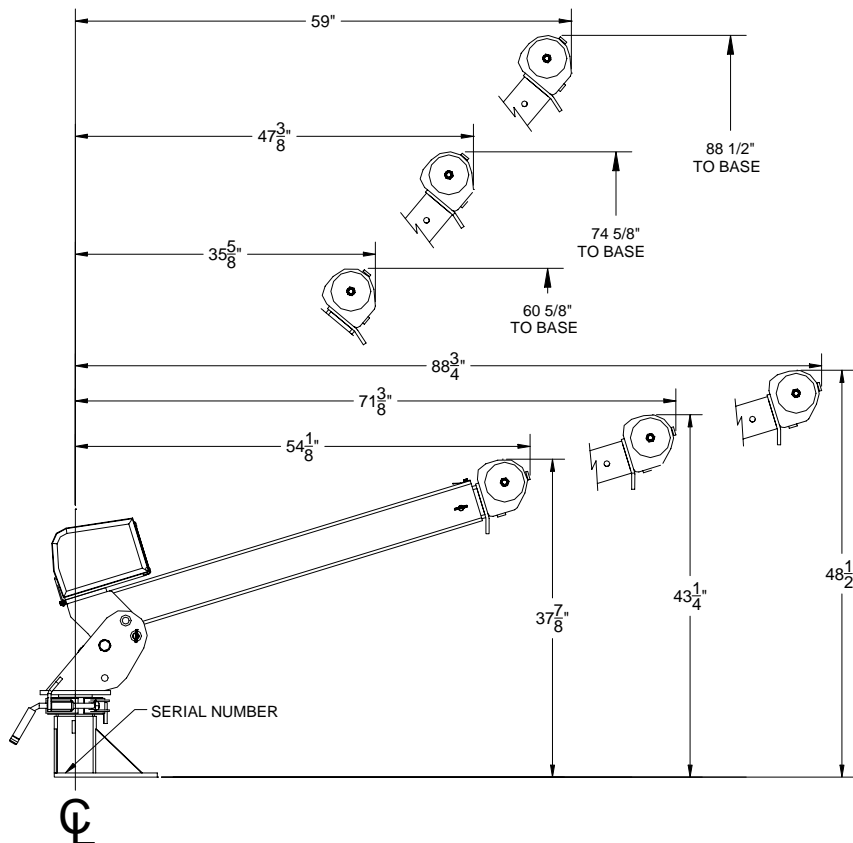
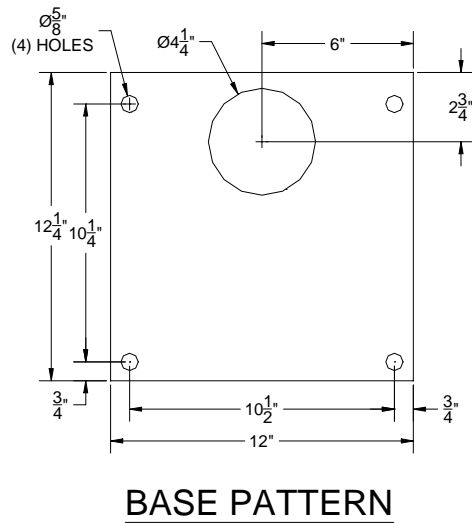
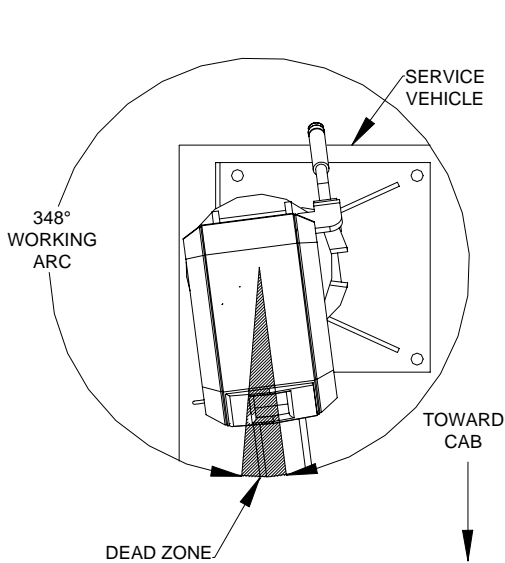

ECONO-TON II GENERAL DIMENSIONS – 5' SHORT PEDESTAL

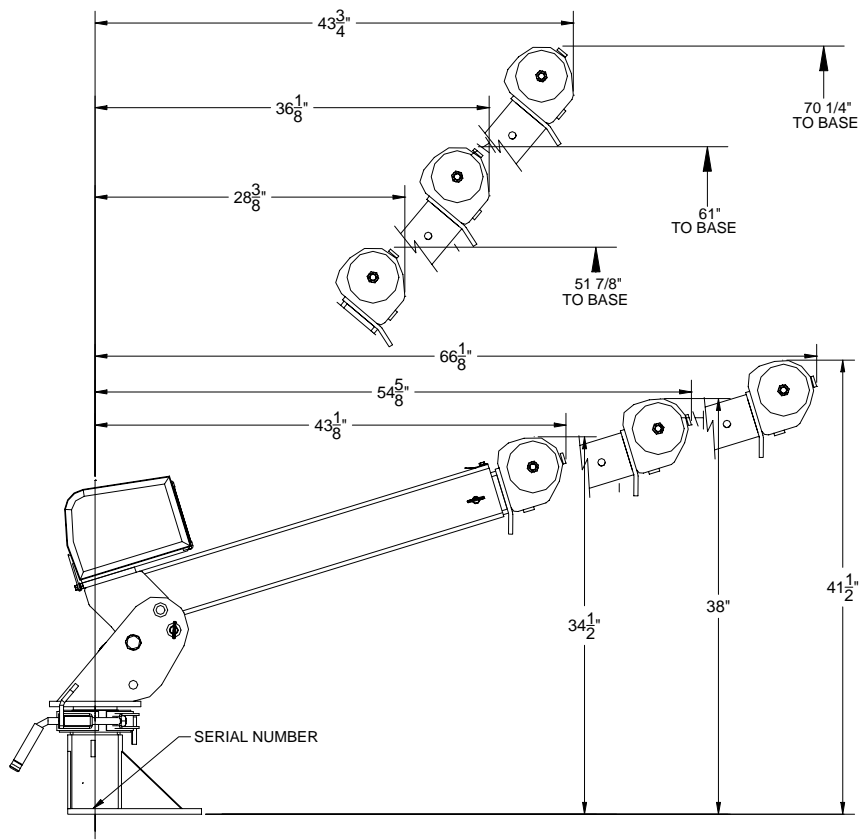
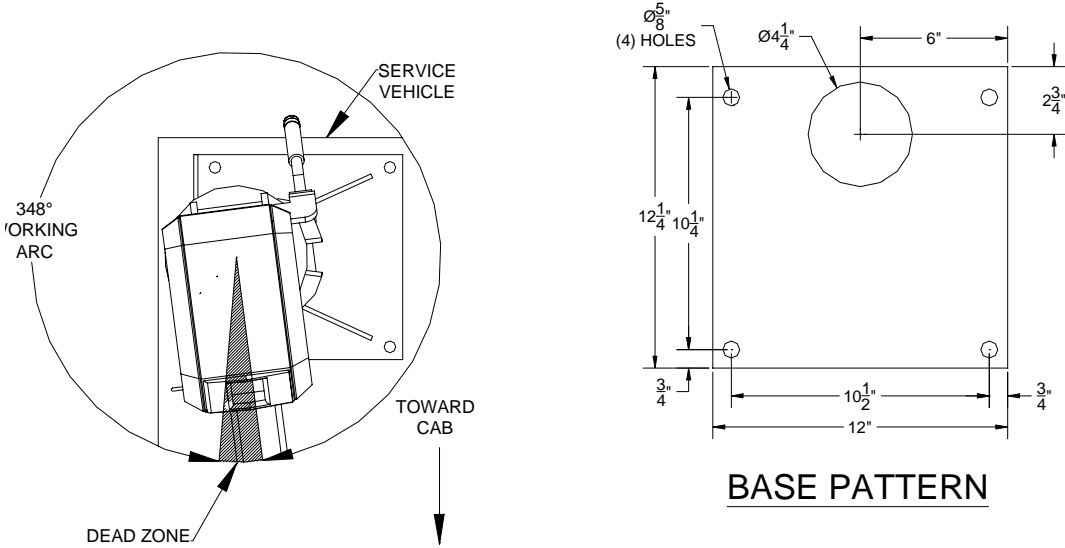

ECONO-TON II/R
DECAL KIT 7' BOOM SHORT PEDESTAL
P/N: 370872020

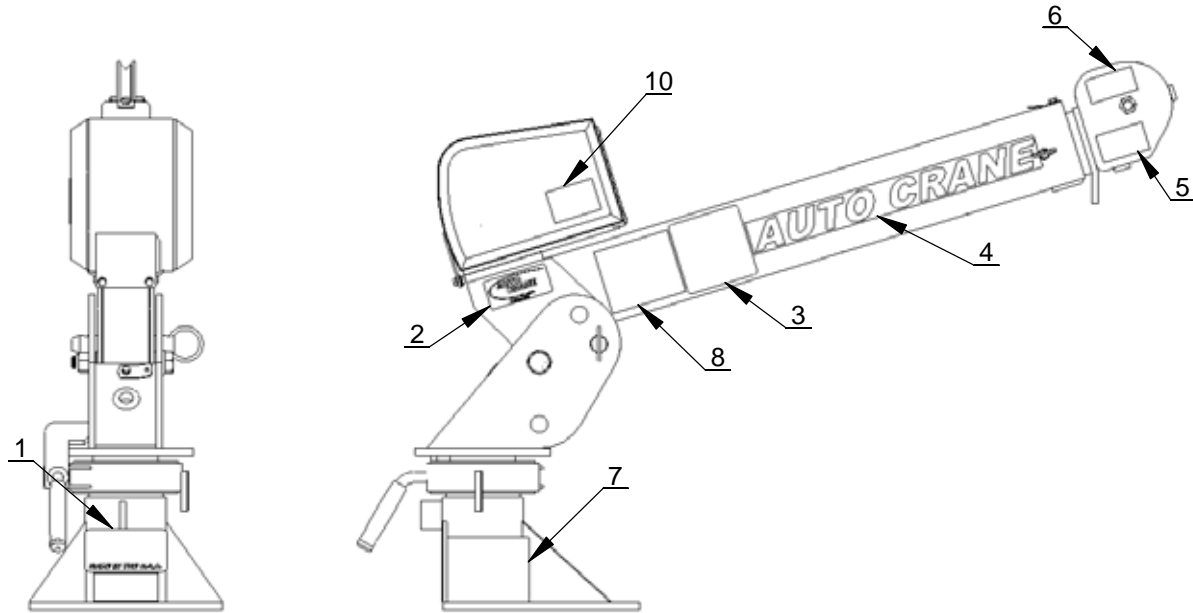

ITEM NO.	QTY.	PART NO.	DESCRIPTION
1	1	040824000	DECAL, AMERICAN FLAG, MADE IN THE U.S.A.
2	2	040619001	DECAL AUTO CRANE LOGO
3	2	370873020	DECAL, LOAD CHART 7' BOOM SHORT PED
4	2	600047000	DECAL AUTO CRANE
5	2	040630000	DECAL DANGER "STAY CLEAR OF LOAD"
6	2	040517000	DECAL STAY CLEAR OF BOOM
7	2	370495000	DECAL, CAUTION "INSPECT VEHICLE..."
8	2	370496000	DECAL, DANGER "UNTRAINED OPERATOR"
9	1	330622000	DECAL SERIAL NO
10	2	370873040	DECAL, CAUTION "ROPE TENSION"

ECONO-TON II/R

MOUNTING AND INSTALLATION

1. Check to make sure the following items are with your crane.

ITEM	QTY II R	QTY II	PART NO.	DESCRIPTION
1	1	1	999938000	OWNER'S MANUAL (ECONO-TON)
2		1	370876001	MANUAL ROTATE PENDANT ASSY
3	1		370885000	POWERED ROTATE PENDANT ASSY
4	4	4	370890000	5/8-18UNF HEX BOLT 2-1/2"LG
5	4	4	370891000	5/8-18UNF HEX NUT
6	4	4	023800000	5/8 LOCKNUT
7	4	4	407314000	5/8 FLAT WASHER
8	6	6	083800000	CABLE CLIPS
9	1	1	272155000	EMERGENCY HANDLE FOR WINCH

2. Vehicle should meet minimum GVW rating of 5,200 pounds. (does not include bodies or accessories)
3. Make sure mounting surface is properly reinforced to withstand 6,500 ft-lb capacity and a 2000 lb vertical loading of crane and that outriggers are used to provide total stability for the truck.
Note: If the floor is made of wood, it may be desirable to install a 3/8" plate approximately six to eight inches larger than the base plate on top of the wooden deck.
4. Position the crane and use the base plate as a template to drill the mounting holes through the truck bed and additional plates if used. Refer to pages 5-6.0 & 5-7.0 for typical installation layouts.
5. Make sure the mounting bolts are 5/8"-18UNF, grade 8. Torque bolts to 128 ft-lbs (dry). Fillers may be required when mounting the crane to a ribbed floor.
6. Run long cable to positive battery terminal. Run short cable to a suitable chassis ground point. Locate cables so that they will be protected. Avoid sharp edges. Use the frame clips provided to hold cables securely in place.
Note: If the battery is grounded to the engine it may be necessary to add an additional ground cable from the engine to the chassis frame to obtain maximum power at crane.
IMPORTANT!! AutoCrane recommends using a 80 amp manual reset circuit breaker installed between the battery and crane to protect electrical system. This should be located near battery.
7. Load test the crane to ensure proper functioning and truck stability
8. When crane is not in operation, a boom should be pinned in the stored position, pendant removed, and rotation brake set.
9. Make certain the owner's manual is delivered to the customer.
10. For additional help: call the service department at the Auto Crane Company. (918) 836-0463 (Tulsa, Oklahoma)

WARNING

FEDERAL LAW (49 CFR PART 571) REQUIRES THAT THE FINAL STAGE MANUFACTURER OF A VEHICLE CERTIFY THAT HE VEHICLE COMPLIES WITH ALL APPLICABLE FEDERAL REGULATIONS. ANY MODIFICATIONS PERFORMED ON THE VEHICLE PRIOR TO THE FINAL STAGE ARE ALSO CONSIDERED INTERMEDIATE STAGE MANUFACTURING AND MUST BE CERTIFIED AS TO COMPLIANCE. THE INSTALLER OF THIS CRANE AND BODY IS CONSIDERED ONE OF THE MANUFACTURERS OF THE VEHICLE. AS SUCH A MANUFACTURER, THE INSTALLER IS RESPONSIBLE FOR COMPLIANCE WITH ALL APPLICABLE FEDERAL AND STATE REGULATIONS, AND IS REQUIRED TO CERTIFY THAT THE VEHICLE IS IN COMPLIANCE.

IT IS THE FURTHER RESPONSIBILITY OF THE INSTALLER OF THE CRANE TO COMPLY WITH THE OSHA TRUCK CRANE STABILITY REQUIREMENTS AS SPECIFIED BY 29 CFR PART 1910.180 (C) (1).

ECONO-TON II/R MOUNTING AND INSTALLATION

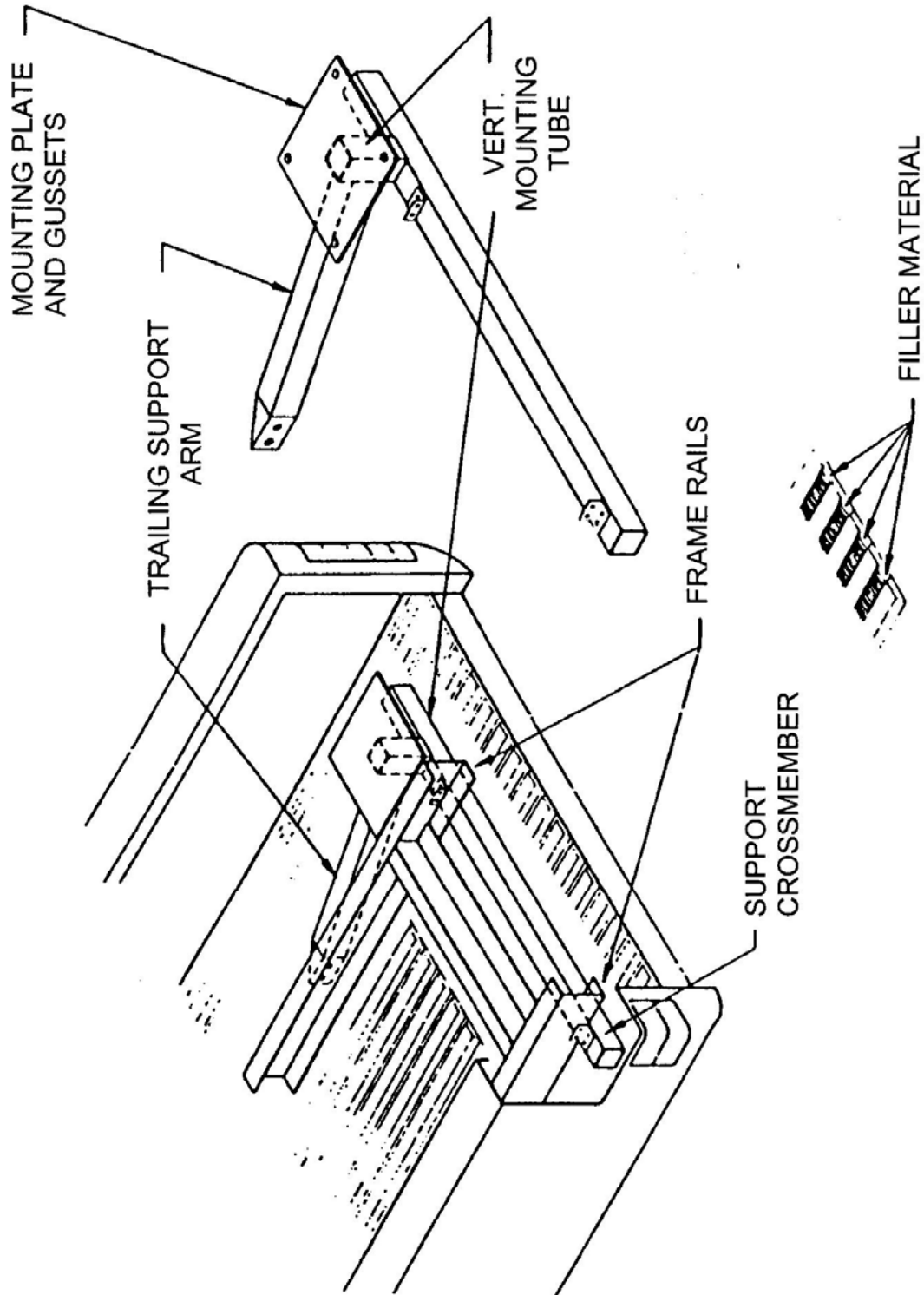

ECONO-TON II/R MOUNTING AND INSTALLATION

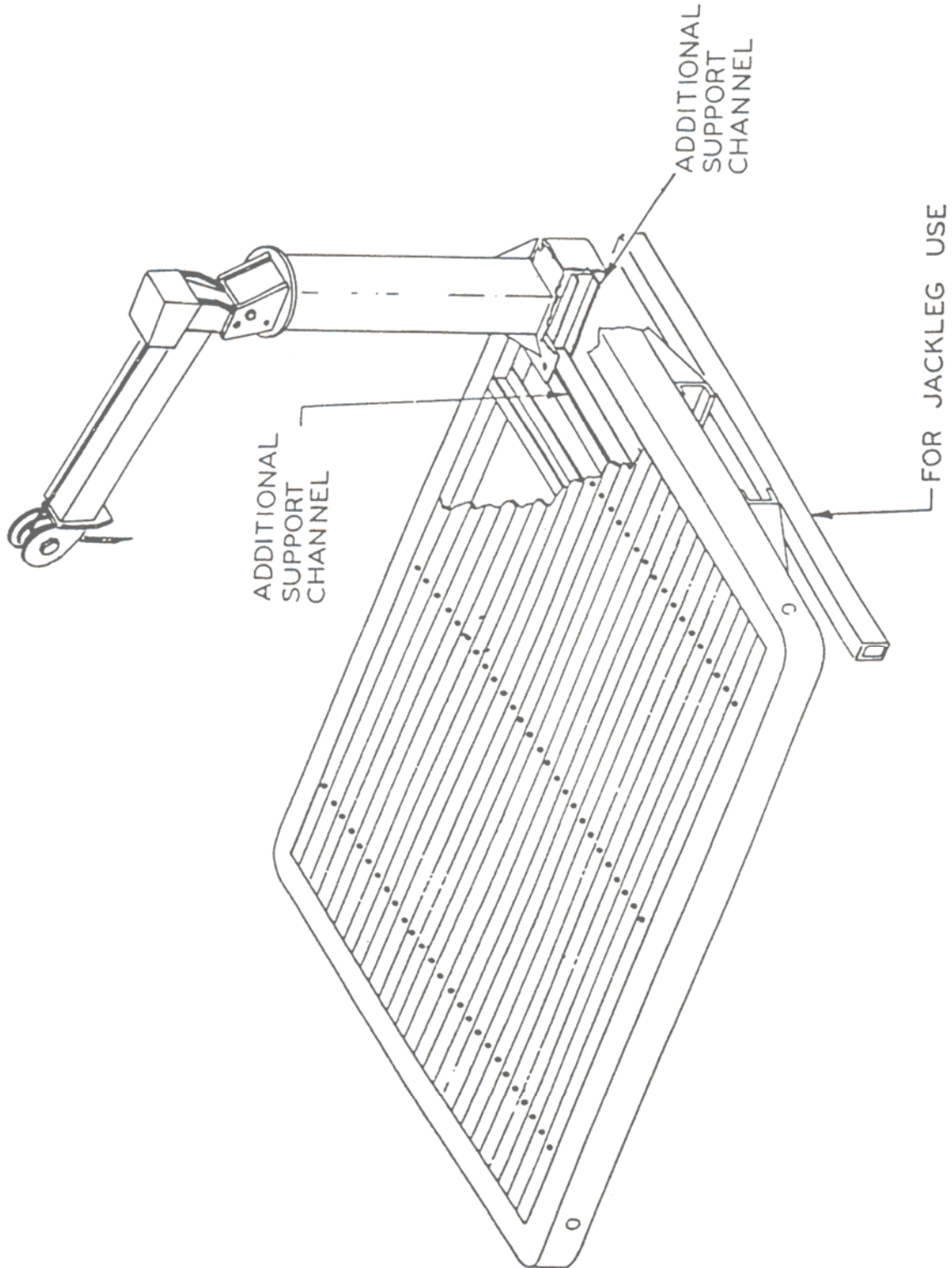

ECONO-TON II/R

MOUNTING AND INSTALLATION

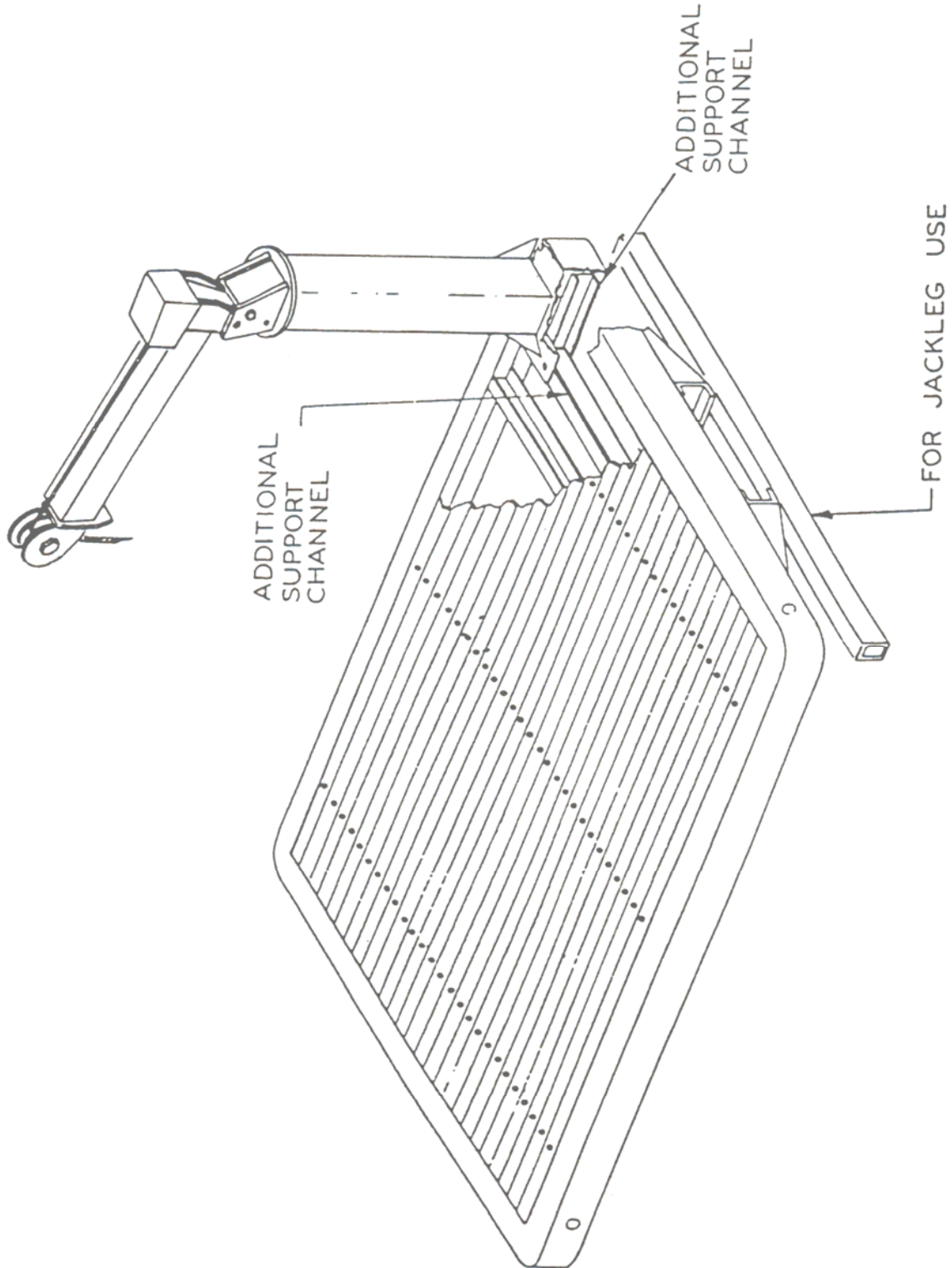

ECONO-TON II GENERAL ASSEMBLY 7' BOOM STD PEDESTAL – P/N:370870000

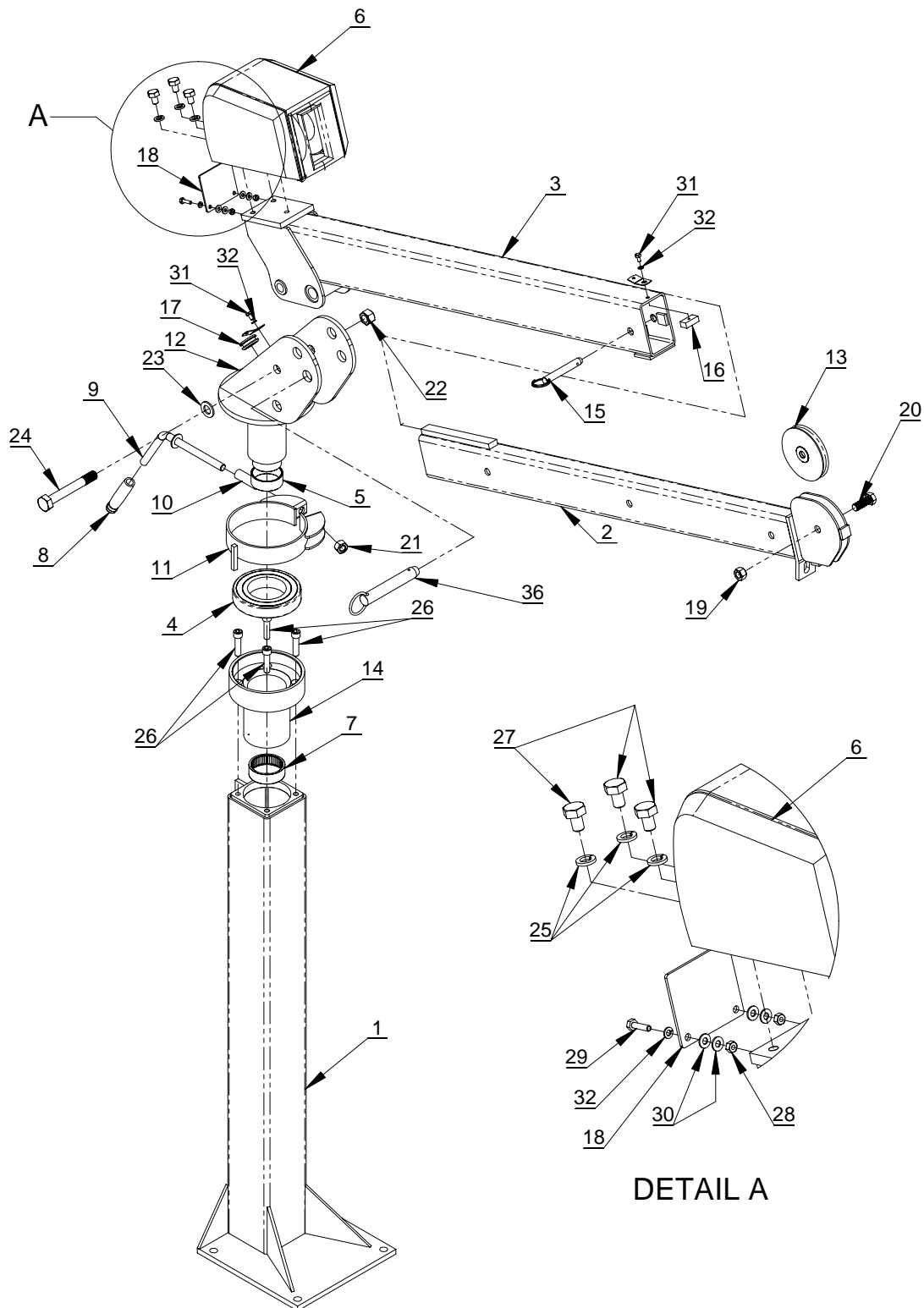

ECONO-TON II GENERAL ASSEMBLY 7' BOOM STD PEDESTAL – P/N:370870000

ITEM NO.	QTY.	PART NO.	DESCRIPTION
1	1	370881000	PEDESTAL WELD - 7' BOOM
2	1	370884000	UPPER BOOM WELDMENT 7' BOOM
3	1	370883000	LOWER BOOM WELDMENT 7' BOOM
4	1	330192000	BEARING, BALL
5	1	370034000	BEARING, RACE
6	1	370876000	ECONO-TON WINCH ASS'Y
7	1	370033000	BEARING, NEEDLE ROLLER
8	1	272055000	HAND GRIP
9	1	371048000	BRAKE HANDLE
10	1	370220000	SPACER HANDLE
11	1	370889000	BRAKE BAND, ECONO-TON
12	1	370879000	QUILL WELDMENT
13	1	370893000	SHEAVE ASS'Y (BEARING ONLY 370893002)
14	1	370878000	QUILL HOUSING (MACHINED)
15	1	370002000	PIN, LOCKING
16	1	370005000	EXTENSION LOCK PAD
17	1	370186000	GROMMET WIRE-GUIDE
18	1	370886000	WINCH COVER PLATE
19	1	370893003	NUT HEX 3/4-16UNF THIN NYLOCK GR5
20	1	370893004	SCREW, HEX HD 3/4-16UNF 2LG GR 5
21	1	018301000	NUT HX 5/8 NCCP
22	1	018600000	NUT HX NYLK 3/4-16UNF CP
23	1	022102000	WASHER FL 3/4
24	1	370882000	SCREW, HEX HD 3/4-5-1/2" LG GR 5
25	3	021500000	WASHER SP LK 1/2
26	4	009118000	SCREW SOC HD 1/2-13UNC X 2 LG
27	3	010000000	SCREW HEX HD 1/2-13UNC X 3/4LG GR 5
28	2	015900000	NUT HX 1/4-20UNC SS
29	2	005604000	SCREW HX HD 1/4-20UNC X 1 LG
30	4	020300000	WASHER FL 1/4
31	2	005901000	SCREW HX HD 1/4-20UNC X 1/2 LG
32	4	020200000	WASHER SP LK 1/4
*33	1	602006000	CONDUCTOR CABLE GRD ET II
*34	1	602005000	CONDUCTOR, POWER CABLE
*35	1	370872000	DECAL KIT, 7'BOOM STD PED
36	1	370888000	PIN ASSY W/LANYARD 4.88 GRIP
*37	1	370892000	SHIP KIT, ECONO-TON

* COMPONENTS NOT SHOWN ON LAYOUT

ECONO-TON II GENERAL ASSEMBLY 5' BOOM STD PEDESTAL – P/N:370870010

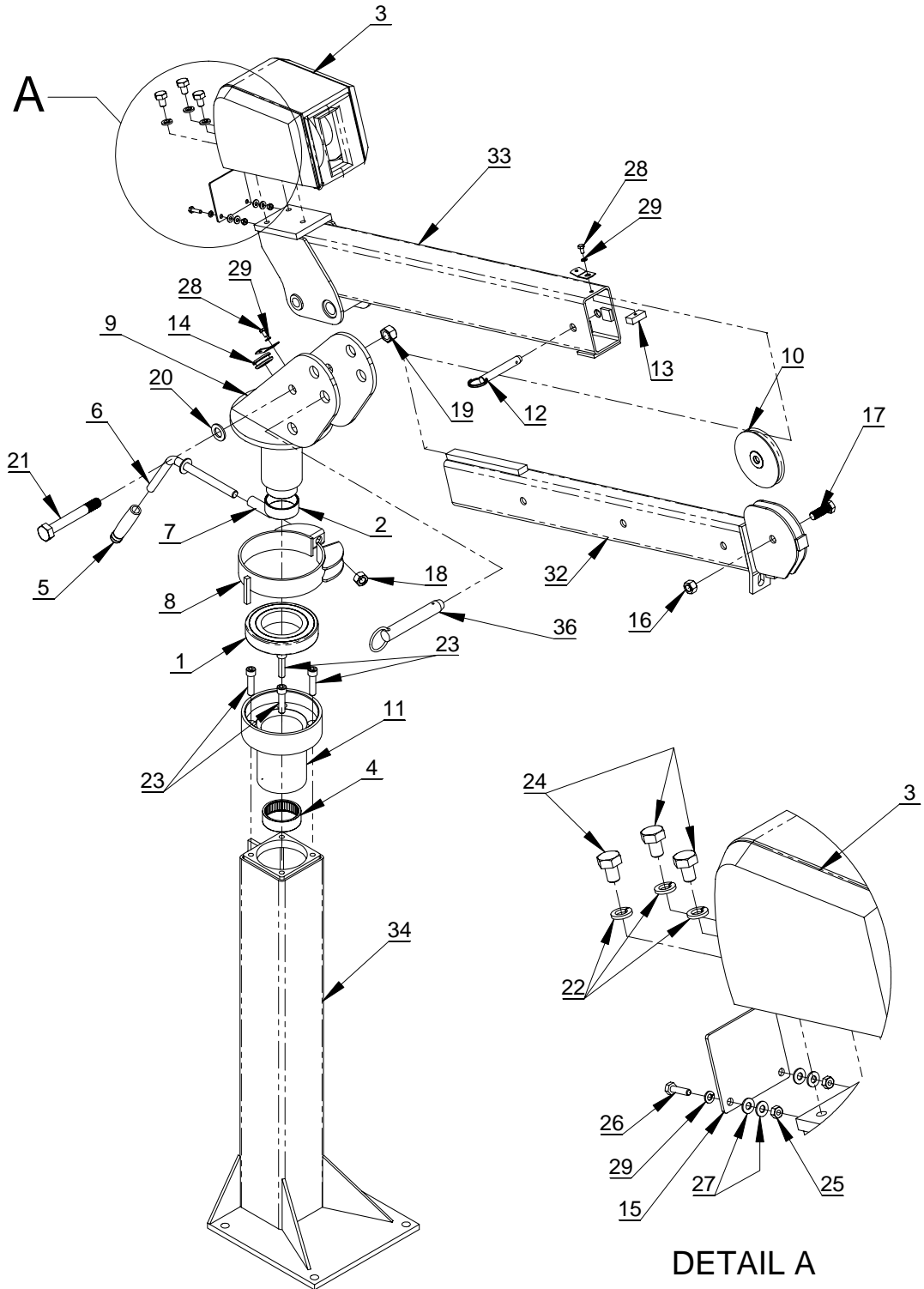

ECONO-TON II GENERAL ASSEMBLY 5' BOOM STD PEDESTAL – P/N:370870010

ITEM NO.	QTY.	PART NO.	DESCRIPTION
1	1	330192000	BEARING, BALL
2	1	370034000	BEARING, RACE
3	1	370876000	ECONO-TON WINCH ASS'Y
4	1	370033000	BEARING, NEEDLE ROLLER
5	1	272055000	HAND GRIP
6	1	371048000	BRAKE HANDLE
7	1	370220000	SPACER HANDLE
8	1	370889000	BRAKE BAND, ECONO-TON
9	1	370879000	QUILL WELDMENT
10	1	370893000	SHEAVE ASS'Y (BEARING ONLY 370893002)
11	1	370878000	QUILL HOUSING (MACHINED)
12	1	370002000	PIN, LOCKING
13	1	370005000	EXTENSION LOCK PAD
14	1	370186000	GROMMET WIRE-GUIDE
15	1	370886000	WINCH COVER PLATE
16	1	370893003	NUT HEX 3/4-16UNF THIN NYLOCK GR5
17	1	370893004	SCREW, HEX HD 3/4-16UNF 2 LG GR 5
18	1	018301000	NUT HX 5/8 NCCP
19	1	018600000	NUT HX NYLK 3/4-16UNF CP
20	1	022102000	WASHER FL 3/4
21	1	370882000	SCREW, HEX HD 3/4-5-1/2" LG GR 5
22	3	021500000	WASHER SP LK 1/2
23	4	009118000	SCREW SOC HD 1/2-13UNC X 2 LG
24	3	010000000	SCREW HEX HD 1/2-13UNC X 3/4LG GR 5
25	2	015900000	NUT HX 1/4-20UNC SS
26	2	005604000	SCREW HX HD 1/4-20UNC X 1 LG
27	4	020300000	WASHER FL 1/4
28	2	005901000	SCREW HX HD 1/4-20UNC X 1/2 LG
29	4	020200000	WASHER SP LK 1/4
*30	1	602006000	CONDUCTOR CABLE GRD ET II
*31	1	602005000	CONDUCTOR, POWER CABLE
32	1	370884010	UPPER BOOM WELDMENT 5' BOOM
33	1	370883010	LOWER BOOM WELDMENT 5' BOOM
34	1	370881010	PEDESTAL BASE WELD - 5' BOOM
*35	1	370872010	DECAL KIT, 5' BOOM STD PED
36	1	370888000	PIN ASSY W/LANYARD 4.88 GRIP
*37	1	370892000	SHIP KIT, ECONO-TON

* COMPONENTS NOT SHOWN ON LAYOUT

ECONO-TON II GENERAL ASSEMBLY 7' BOOM SHORT PEDESTAL— P/N:370870020

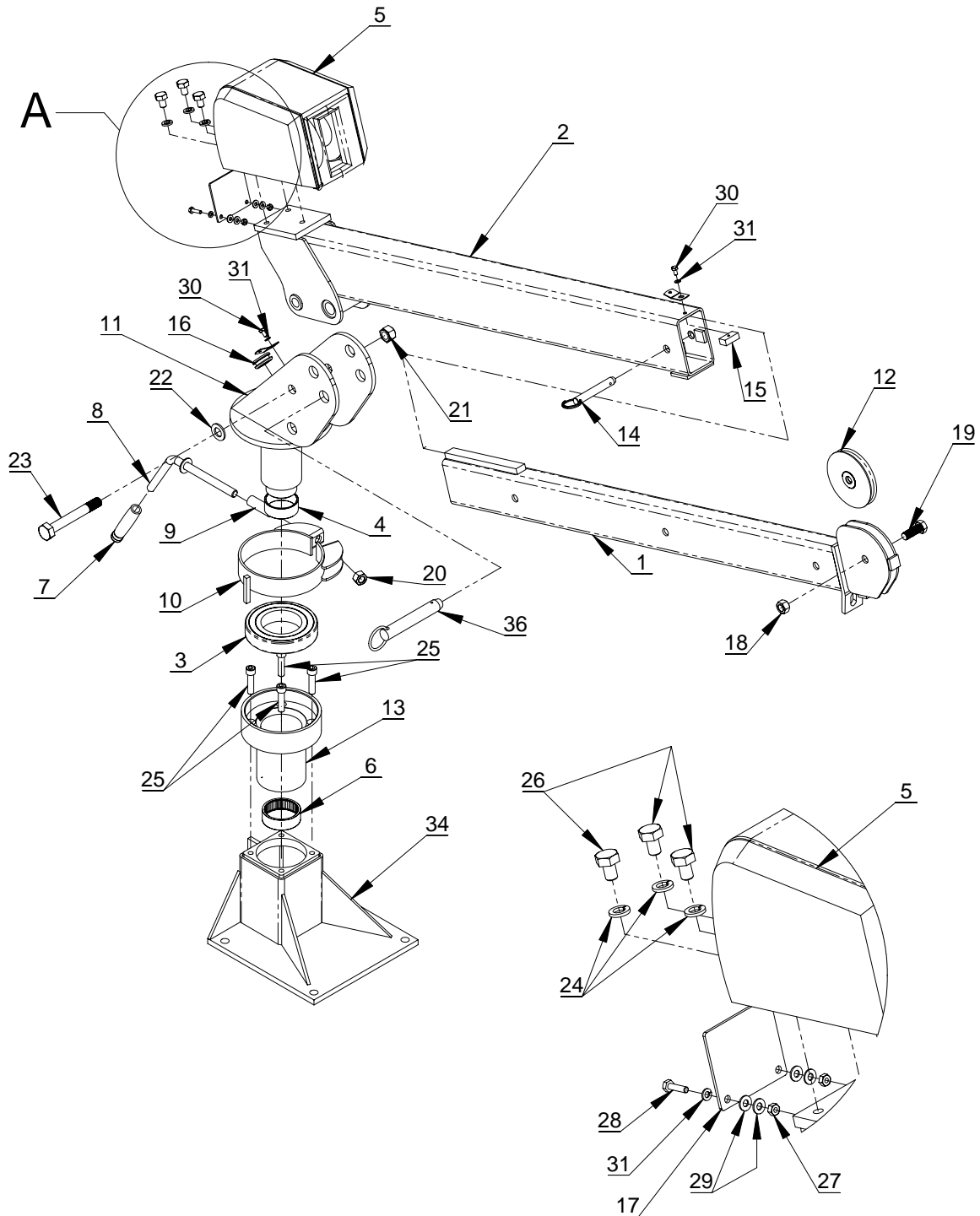

ECONO-TON II GENERAL ASSEMBLY 7' BOOM SHORT PEDESTAL- P/N:370870020

ITEM NO.	QTY.	PART NO.	DESCRIPTION
1	1	370884000	UPPER BOOM WELDMENT 7' BOOM
2	1	370883000	LOWER BOOM WELDMENT 7' BOOM
3	1	330192000	BEARING, BALL
4	1	370034000	BEARING, RACE
5	1	370876000	ECONO-TON WINCH ASS'Y
6	1	370033000	BEARING, NEEDLE ROLLER
7	1	272055000	HAND GRIP
8	1	371048000	BRAKE HANDLE
9	1	370220000	SPACER HANDLE
10	1	370889000	BRAKE BAND, ECONO-TON
11	1	370879000	QUILL WELDMENT
12	1	370893000	SHEAVE ASS'Y (BEARING ONLY 370893002)
13	1	370878000	QUILL HOUSING (MACHINED)
14	1	370002000	PIN, LOCKING
15	1	370005000	EXTENSION LOCK PAD
16	1	370186000	GROMMET WIRE-GUIDE
17	1	370886000	WINCH COVER PLATE
18	1	370893003	NUT HEX 3/4-16UNF THIN NYLOCK GR5
19	1	370893004	SCREW, HEX HD 3/4-16UNF 2 LG GR 5
20	1	018301000	NUT HX 5/8 NCCP
21	1	018600000	NUT HX NYLK 3/4-16UNF CP
22	1	022102000	WASHER FL 3/4
23	1	370882000	SCREW, HEX HD 3/4-5-1/2" LG GR 5
24	3	021500000	WASHER SP LK 1/2
25	4	009118000	SCREW SOC HD 1/2-13UNC X 2 LG
26	3	010000000	SCREW HEX HD 1/2-13UNC X 3/4LG GR 5
27	2	015900000	NUT HX 1/4-20UNC SS
28	2	005604000	SCREW HX HD 1/4-20UNC X 1 LG
29	4	020300000	WASHER FL 1/4
30	2	005901000	SCREW HX HD 1/4-20UNC X 1/2 LG
31	4	020200000	WASHER SP LK 1/4
*32	1	602006000	CONDUCTOR CABLE GRD ET II
*33	1	602005000	CONDUCTOR, POWER CABLE
34	1	370881020	PEDESTAL BASE WELD - SHORT PED
*35	1	370872020	DECAL KIT, 7' BOOM SHORT PED.
36	1	370888000	PIN ASSY W/LANYARD 4.88 GRIP
*37	1	370892000	SHIP KIT, ECONO-TON

* COMPONENTS NOT SHOWN ON LAYOUT

ECONO-TON II GENERAL ASSEMBLY

5' BOOM SHORT PEDESTAL- P/N:370870030

ITEM NO.	QTY.	PART NO.	DESCRIPTION
1	1	330192000	BEARING, BALL
2	1	370034000	BEARING, RACE
3	1	370876000	ECONO-TON WINCH ASS'Y
4	1	370033000	BEARING, NEEDLE ROLLER
5	1	272055000	HAND GRIP
6	1	371048000	BRAKE HANDLE
7	1	370220000	SPACER HANDLE
8	1	370889000	BRAKE BAND, ECONO-TON
9	1	370879000	QUILL WELDMENT
10	1	370893000	SHEAVE ASS'Y (BEARING ONLY 370893002)
11	1	370878000	QUILL HOUSING (MACHINED)
12	1	370002000	PIN, LOCKING
13	1	370005000	EXTENSION LOCK PAD
14	1	370186000	GROMMET WIRE-GUIDE
15	1	370886000	WINCH COVER PLATE
16	1	370893003	NUT HEX 3/4-16UNF THIN NYLOCK GR5
17	1	370893004	SCREW, HEX HD 3/4-16UNF 2 LG GR 5
18	1	018301000	NUT HX 5/8 NCCP
19	1	018600000	NUT HX NYLK 3/4-16UNF CP
20	1	022102000	WASHER FL 3/4
21	1	370882000	SCREW, HEX HD 3/4-5-1/2" LG GR 5
22	3	021500000	WASHER SP LK 1/2
23	4	009118000	SCREW SOC HD 1/2-13UNC X 2 LG
24	3	010000000	SCREW HEX HD 1/2-13UNC X 3/4LG GR 5
25	2	015900000	NUT HX 1/4-20UNC SS
26	2	005604000	SCREW HX HD 1/4-20UNC X 1 LG
27	4	020300000	WASHER FL 1/4
28	2	005901000	SCREW HX HD 1/4-20UNC X 1/2 LG
29	4	020200000	WASHER SP LK 1/4
*30	1	602006000	CONDUCTOR CABLE GRD ET II
*31	1	602005000	CONDUCTOR, POWER CABLE
32	1	370884010	UPPER BOOM WELDMENT 5' BOOM
33	1	370883010	LOWER BOOM WELDMENT 5' BOOM
34	1	370881020	PEDESTAL BASE WELD - SHORT PED
*35	1	370872030	DECAL KIT, 5' BOOM SHORT PED
36	1	370888000	PIN ASSY W/LANYARD 4.88 GRIP
*37	1	370892000	SHIP KIT, ECONO-TON

* COMPONENTS NOT SHOWN ON LAYOUT

ECONO-TON II WINCH ASSEMBLY - P/N: 370876000

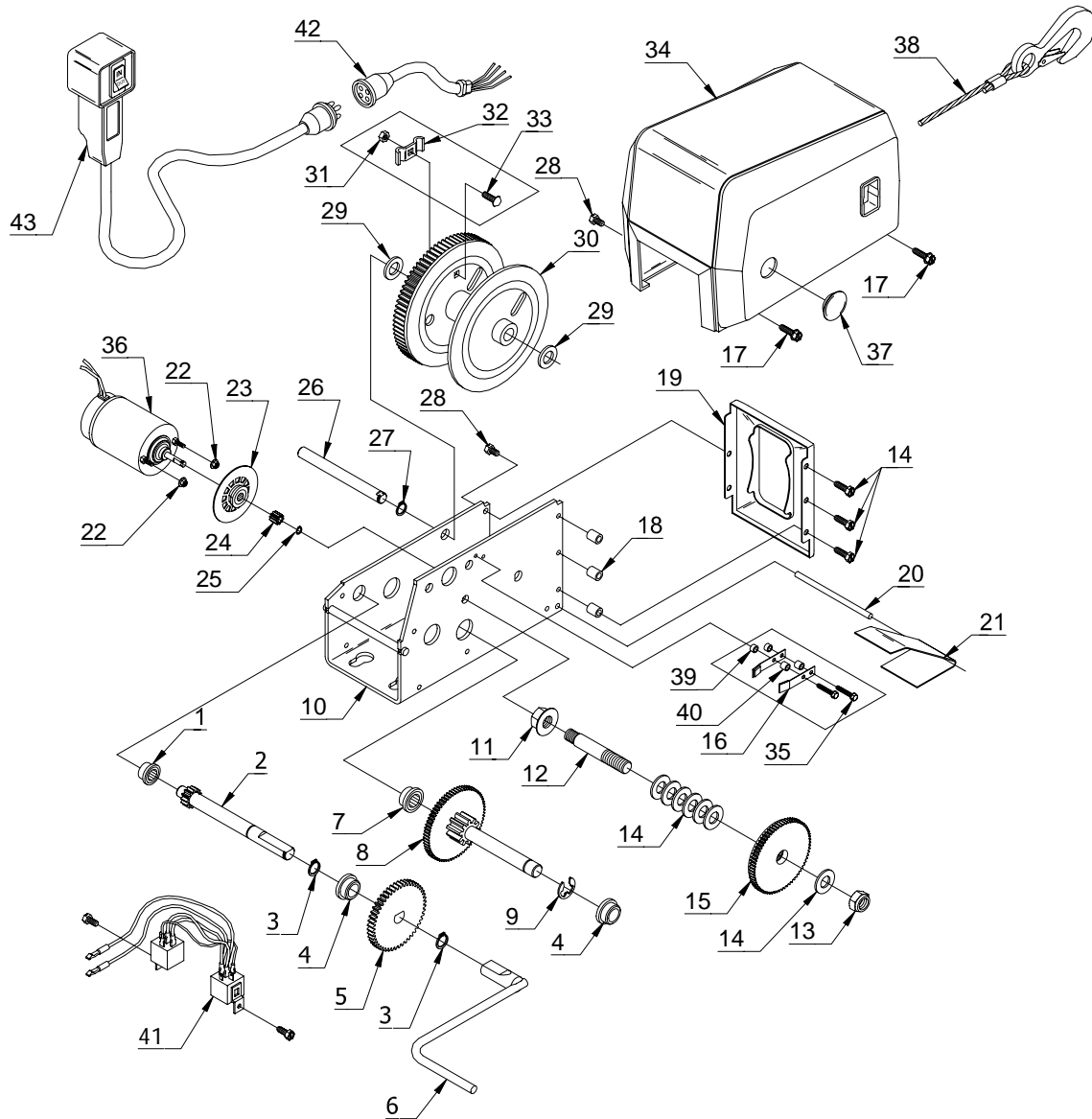

ECONO-TON II

WINCH ASSEMBLY - P/N: 370876000

ITEM NO.	QTY.	PART NO.	DESCRIPTION
1	1	272500000	BEARING HOUSING ASSEMBLY
2	1	272151000	PRIMARY DRIVE SHAFT ASSEMBLY
3	2	272152000	RETAINING RING
4	2	272153000	BUSHING
5	1	272154000	GEAR 56 T
6	1	272155000	HANDLE ASSEMBLY
7	1	272501000	DRIVE SHAFT BEARING HOUSING ASSEMBLY
8	1	272158000	INTERMEDIATE DRIVE SHAFT ASSEMBLY
9	1	272159000	"E" RING
10	1	272160000	BASE
11	1	330011000	NUT HX LK 7/16 NF
12	1	330012000	CLUTCH STUD
13	1	330018000	NUT LK 1/2
14	7	272502000	WASHER
15	1	330015000	GEAR ASSEMBLY
16	2	272434000	BRAKE SPRING ASSEMBLY
17	5	272162000	SCW 1/4 NC X 1 1/16
18	3	272163000	SPACER
19	1	272164000	FRONT PLATE
20	1	272165000	LEVEL WIND PIN
21	1	330019000	LEVEL WIND
22	2	330022000	NUT HX LK #10 NF
23	1	272433000	BRAKE DISC ASSEMBLY
24	1	272170000	12 T PINION GEAR
25	1	272171000	"E" RING
26	1	272173000	REEL SHAFT
27	1	272174000	RETAINING RING
28	4	272175000	SCW 1/4 NC X 3/4
29	2	272176000	WASHER
30	1	272503000	REEL ASSEMBLY
31	1	272179000	NUT HX 1/4 NC
32	1	272180000	ROPE CLAMP
33	1	272504000	CARRAGE BOLT 1/4 NC X 3/4
34	1	272505000	COVER
35	2	272437000	SCW #10 NF X 1
36	1	272184000	MOTOR ASSEMBLY
37	1	272508000	COVER PLUG
38	1	370876003	CABLE & HOOK (1/4 X 25')

NOTES

ECONO-TON II
WINCH ASSEMBLY - P/N: 370876000

ITEM NO.	QTY.	PART NO.	DESCRIPTION
39	2	272435000	SPACER
40	2	272436000	BRAKE SPRING SPACER
41	2	370875004	60/80 AMP RELAY
42	1	370876005	FEMALE PENDANT PLUG
43	1	370876001	PENDANT ASSEMBLY

ECONO-TON II ELECTRICAL SCHEMATIC - P/N: 370887000

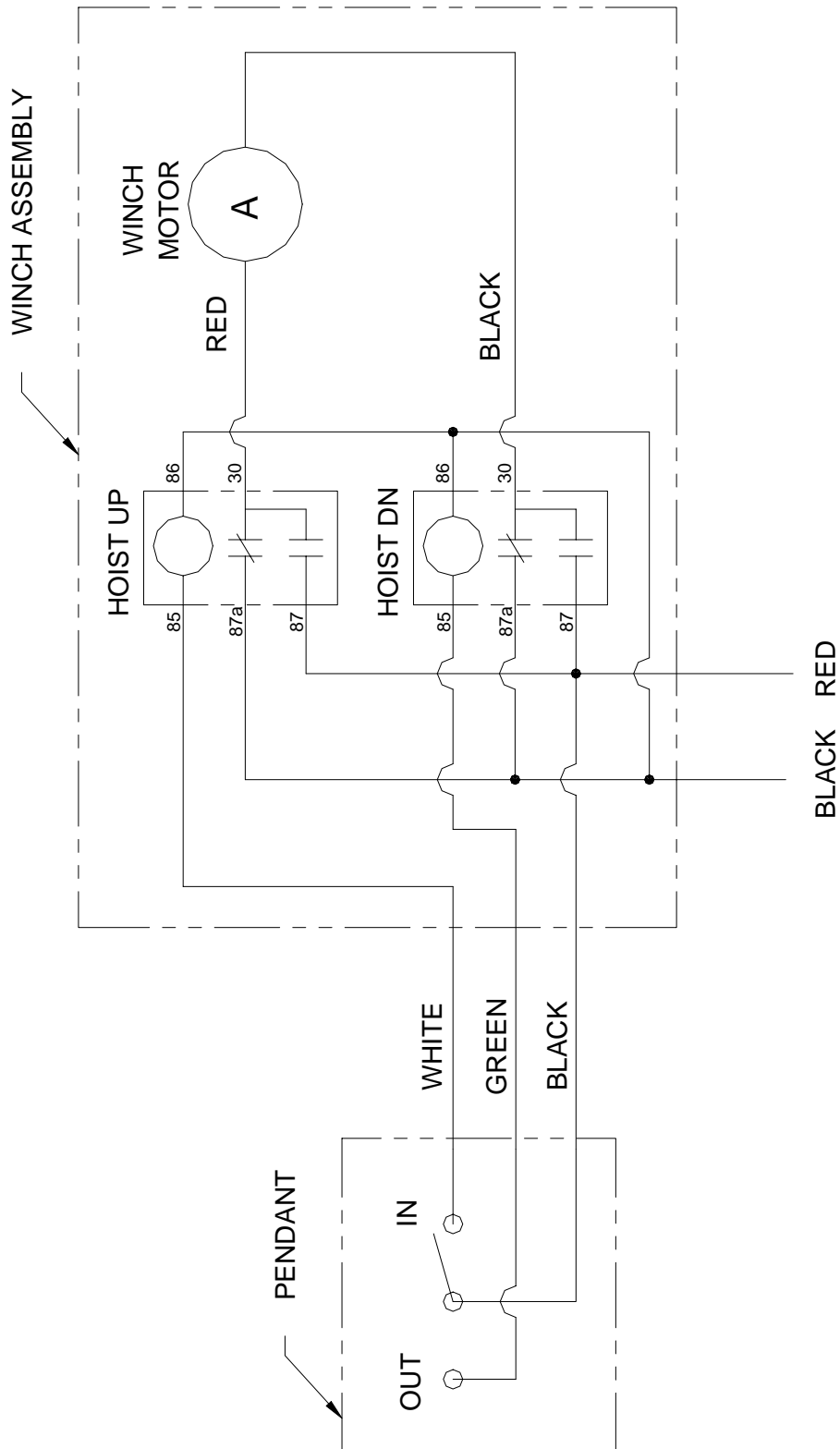

ECONO-TON II

PENDANT ASSEMBLY - P/N: 370876001

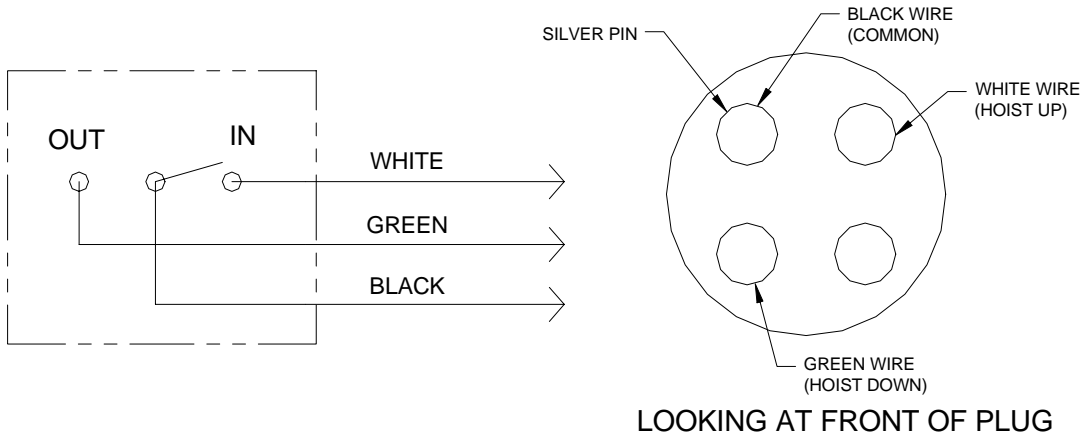
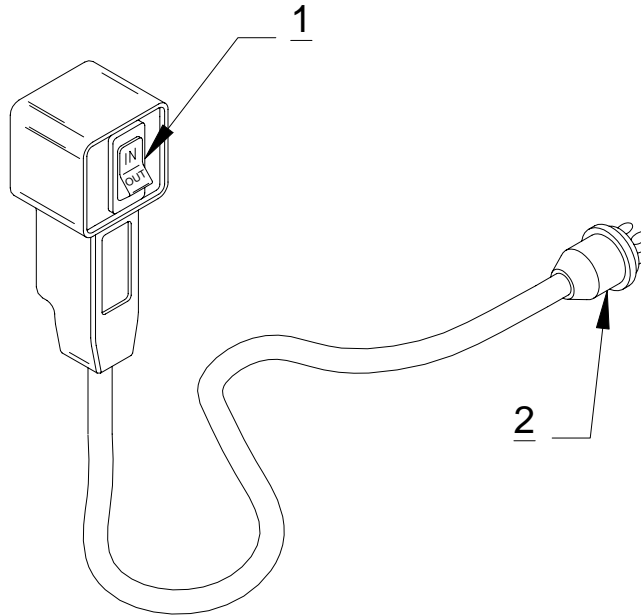

PENDANT ASSEMBLY (370876001) SERVICE PARTS			
ITEM NO.	QTY.	PART NO.	DESCRIPTION
1	1	370876002	TOGGLE SWITCH
2	1	370876004	MALE PENDANT PLUG

NOTES

**ADDENDUM SECTION
ECONO-TON IIR
(POWER ROTATION)**

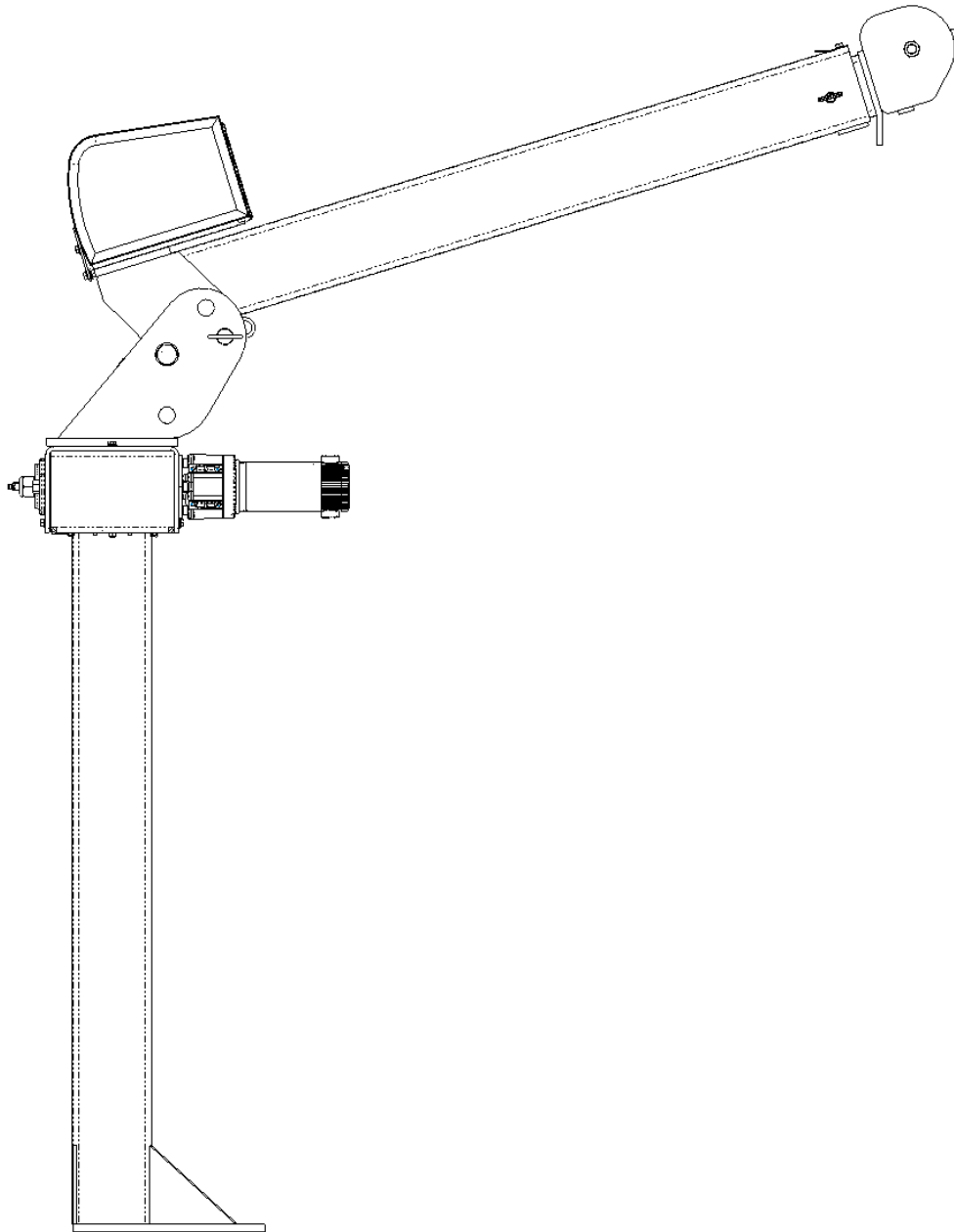

THE FOLLOWING PAGES APPLIES TO THE POWERED ROTATE
ECONO-TON (I.E. ECONO-TON IIR). THE INFORMATION IN THIS
ADDENDUM SUPERSEDES THE INFORMATION ON THE
PREVIOUS PAGES

ECONO-TON IIR GENERAL DIMENSIONS – 7' BOOM

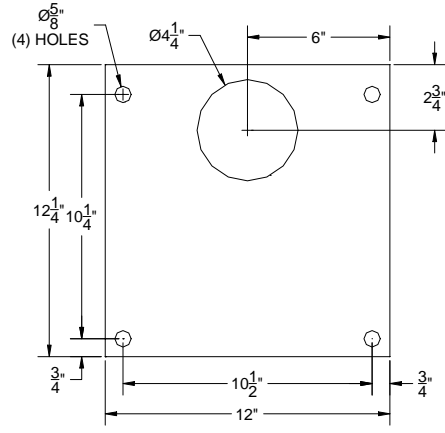
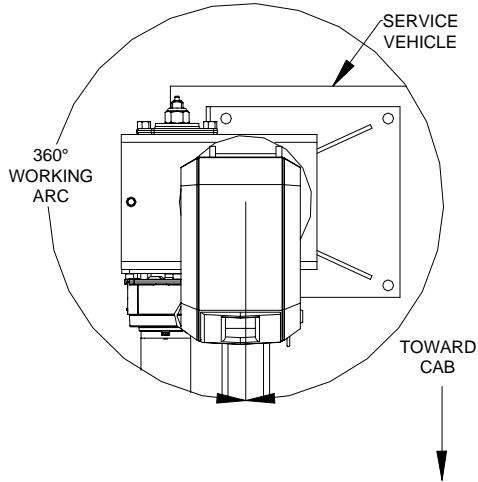

BASE PATTERN

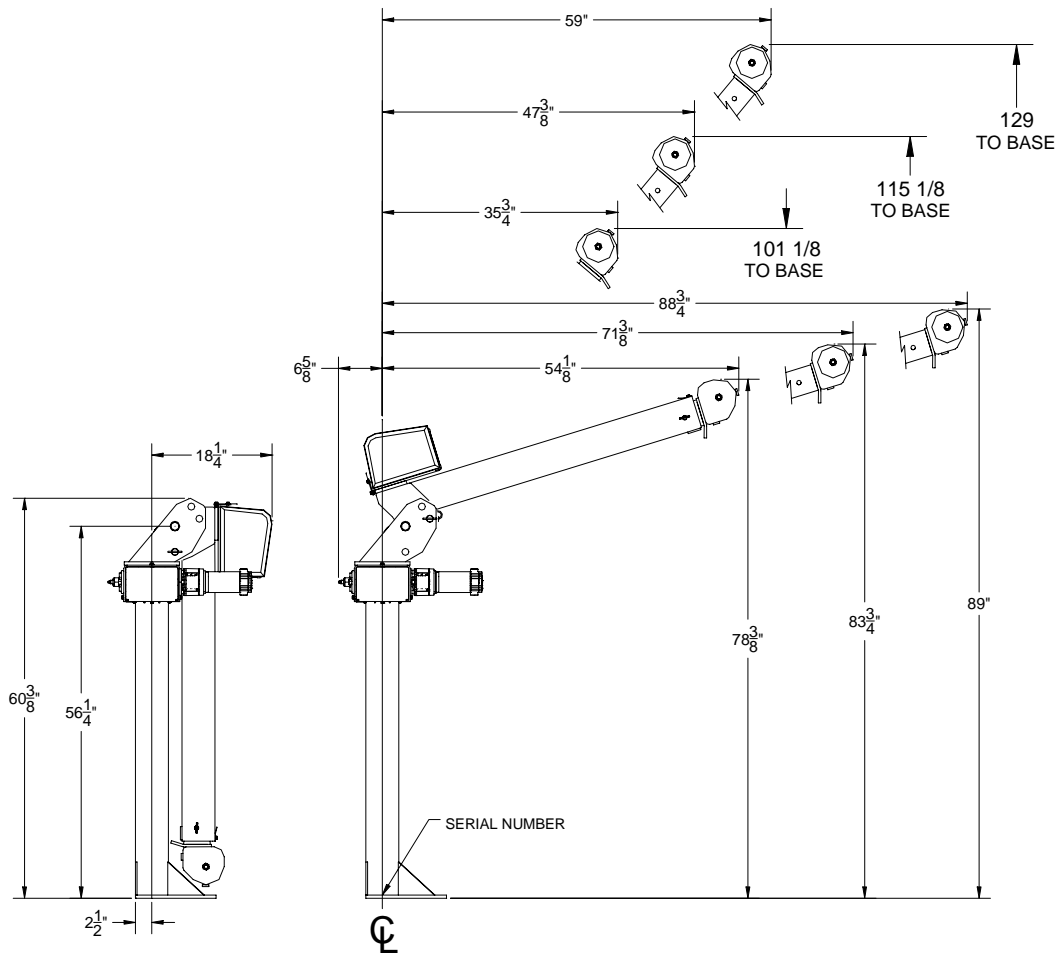

ECONO-TON IIR

GENERAL DIMENSIONS – 5' BOOM

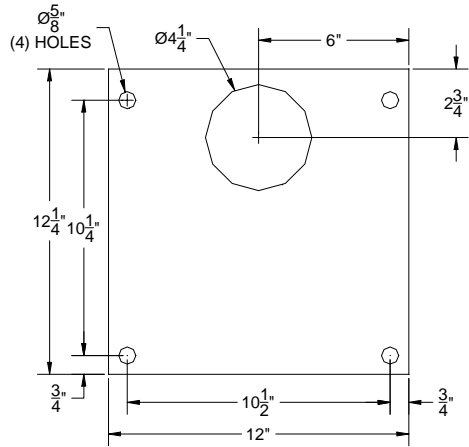
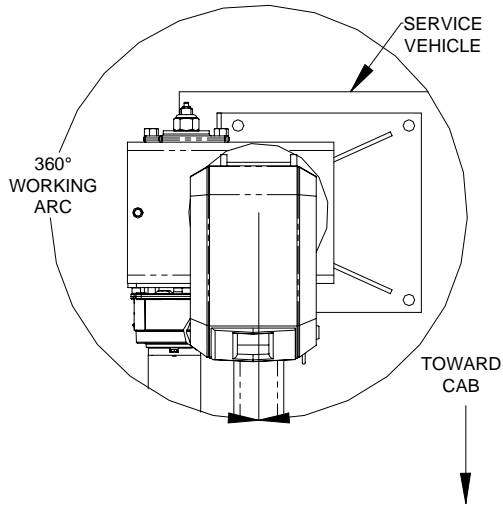

BASE PATTERN

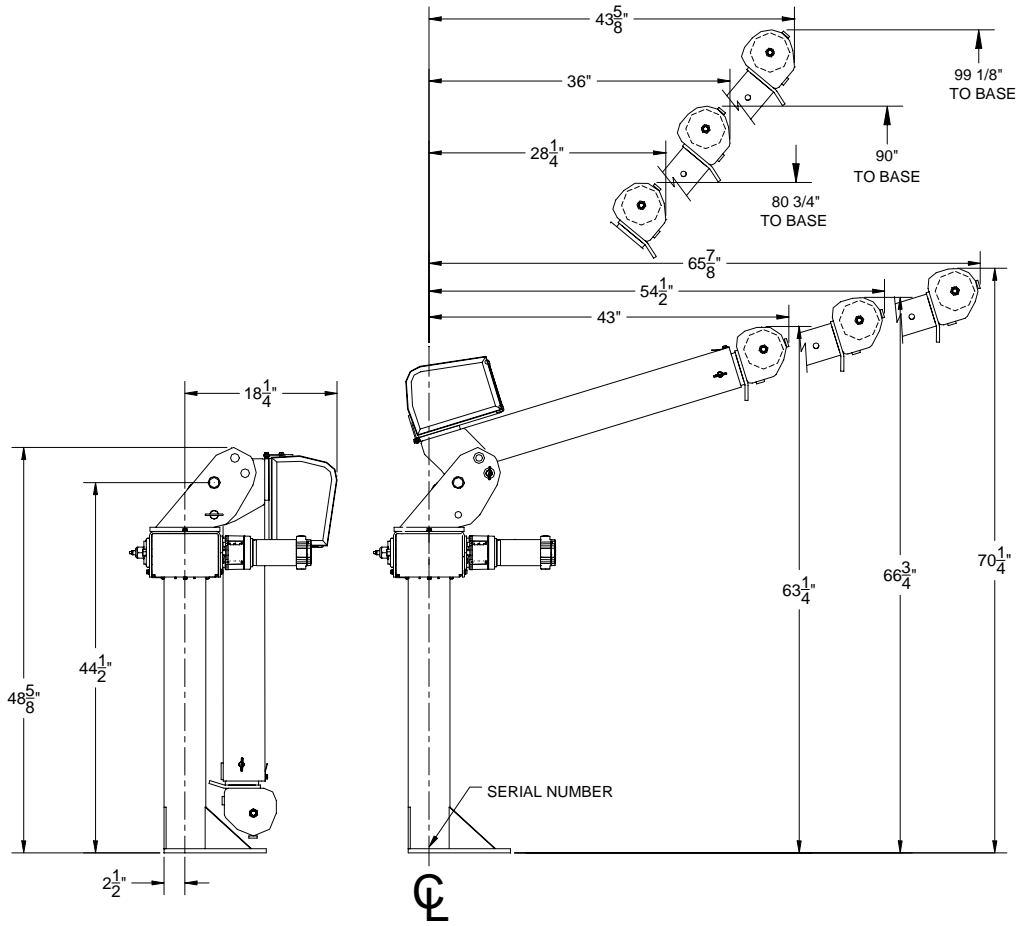

ECONO-TON IIR

GENERAL DIMENSIONS – 7' BOOM SHORT PEDESTAL

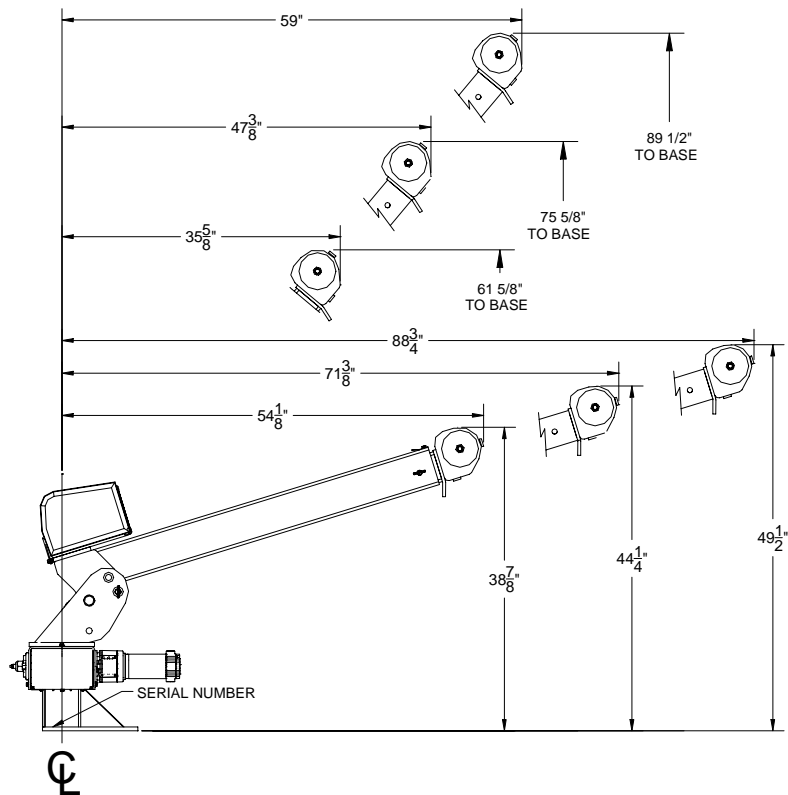
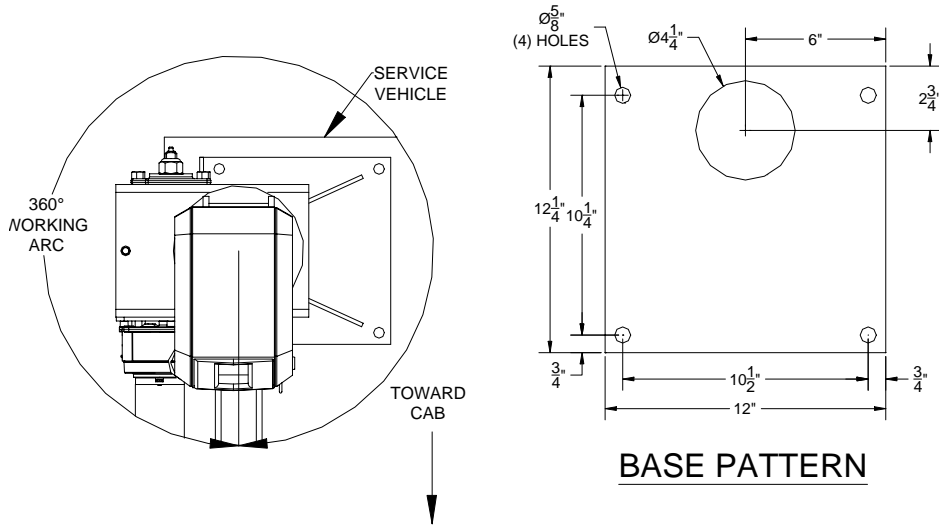

ECONO-TON IIR

GENERAL DIMENSIONS – 5' BOOM SHORT PEDESTAL

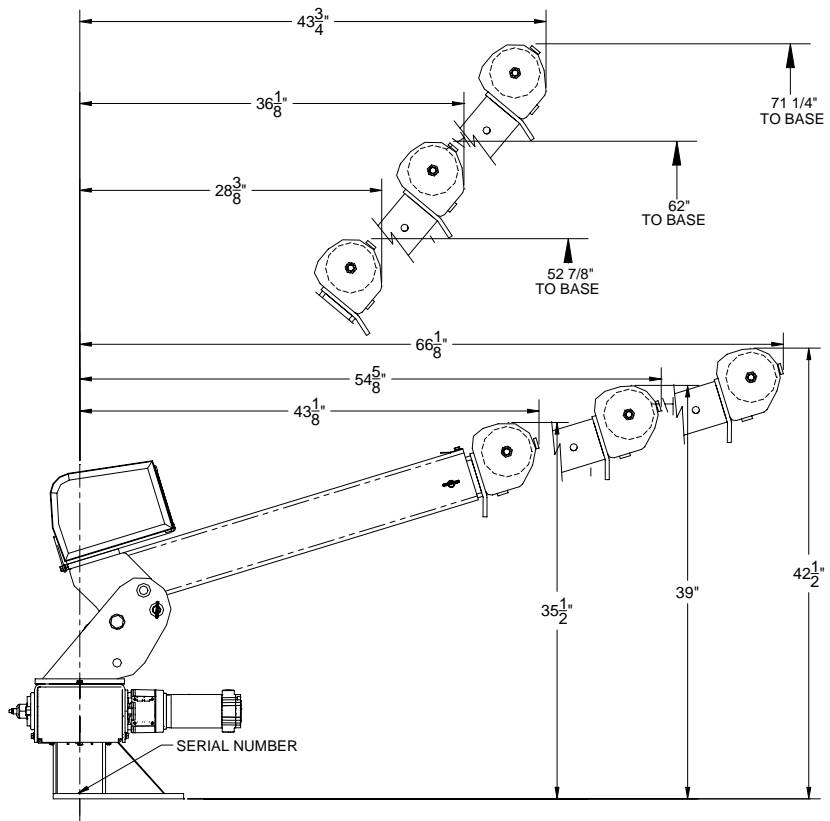
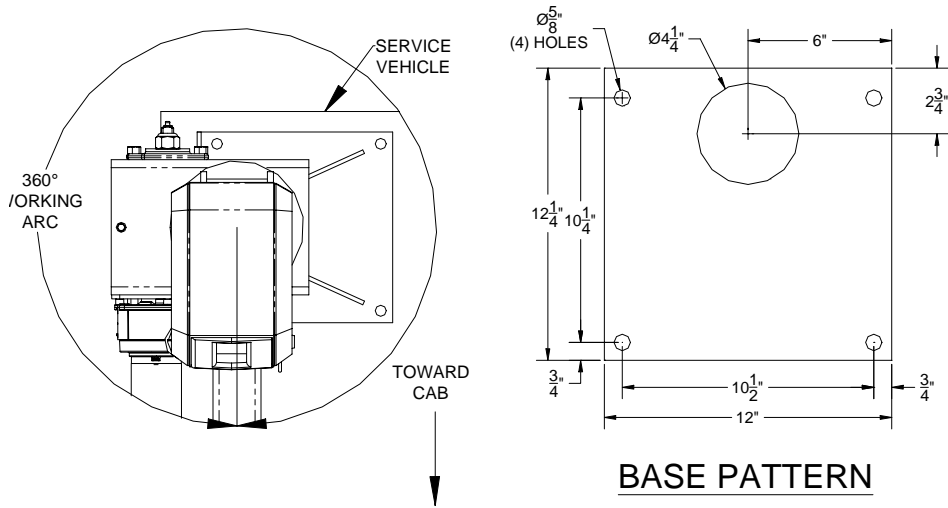

ECONO-TON IIR GENERAL ASSEMBLY 7' BOOM STD PEDESTAL – P/N:370871000

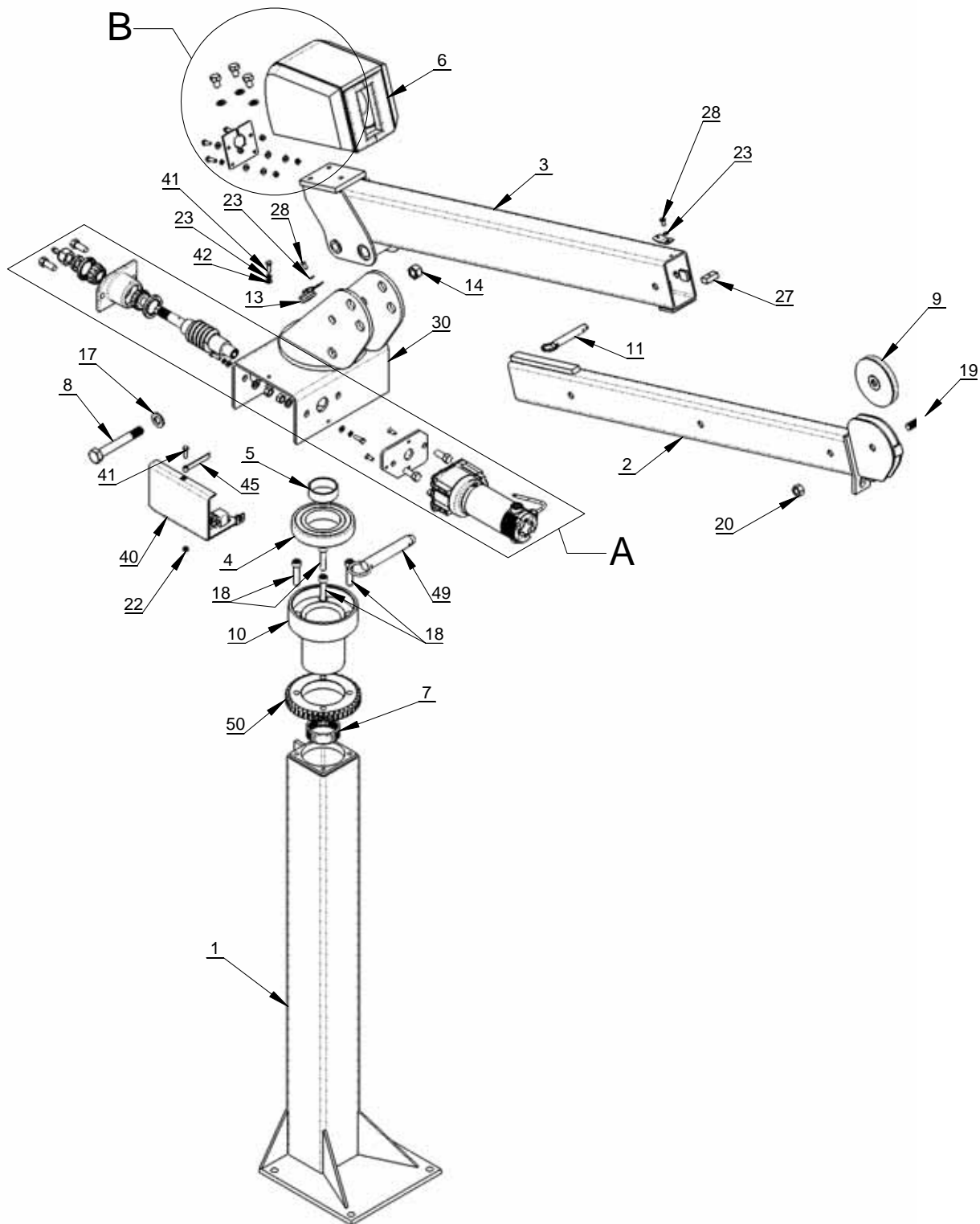

ECONO-TON IIR GENERAL ASSEMBLY 7' BOOM STD PEDESTAL – P/N:370871000

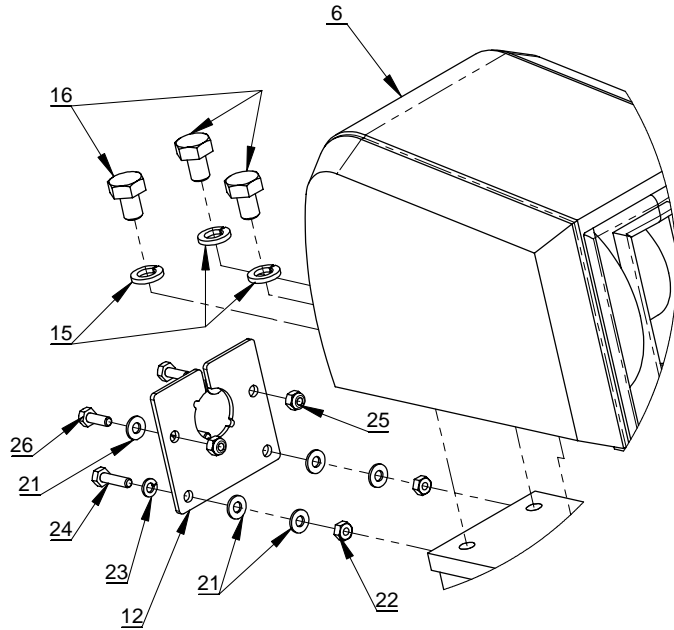

DETAIL B

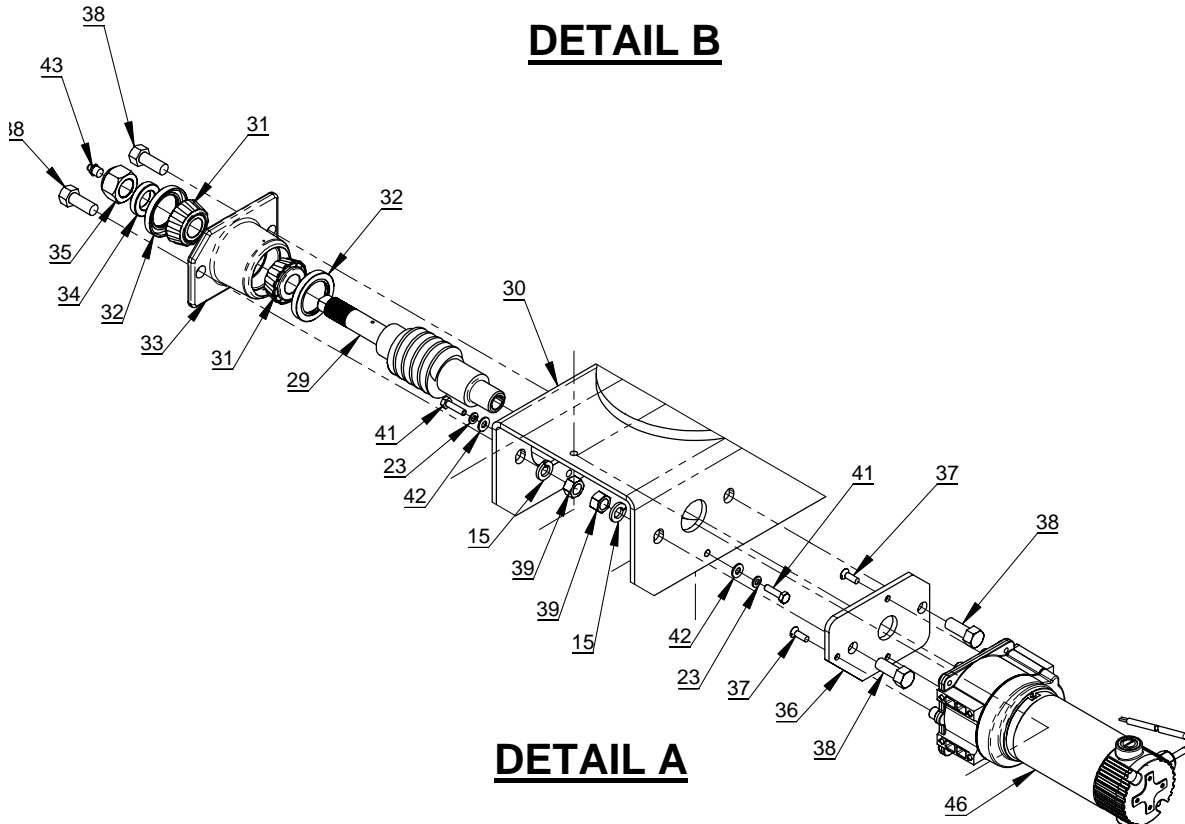

DETAIL A

ECONO-TON IIR GENERAL ASSEMBLY 7' BOOM STD PEDESTAL – P/N:370871000

ITEM NO.	QTY.	PART NO.	DESCRIPTION
1	1	370881000	PEDESTAL WELD - 7' BOOM
2	1	370884000	UPPER BOOM WELDMENT 7' BOOM
3	1	370883000	LOWER BOOM WELDMENT 7' BOOM
4	1	330192000	BEARING, BALL
5	1	370034000	BEARING, RACE
6	1	370877000	WINCH ASS'Y 12 VOLTS DC
7	1	370033000	BEARING, NEEDLE ROLLER
8	1	370882000	SCREW, HEX HD 3/4-5-1/2" LG GR 5
9	1	370893000	SHEAVE ASSEMBLY (BEARING ONLY 370893002)
10	1	370878000	QUILL HOUSING (MACHINED)
11	1	370002000	PIN, LOCKING
12	1	370886001	MOUNT. RECEPTACLE
13	1	370186000	GROMMET WIRE-GUIDE
14	1	018600000	NUT HX NYLK 3/4-16UNF CP
15	7	021500000	WASHER SP LK 1/2
16	3	010000000	SCREW HEX HD 1/2-13UNC X 3/4LG GR 5
17	1	022102000	WASHER FL 3/4
18	4	370878005	SCREW, SOC HD 1/2'-13UNC 2-1/4"LG
19	1	370893004	SCREW, HEX HD 3/4-16UNF 2 LG GR 5
20	1	370893003	NUT HEX 3/4-16UNF THIN NYLOCK GR5
21	6	020300000	WASHER FL 1/4
22	3	015900000	NUT HX 1/4-20UNC SS
23	7	020200000	WASHER SP LK 1/4
24	2	005604000	SCREW HX HD 1/4-20UNC X 1 LG
25	2	016300000	NUT HX NYLK 1/4-20UNC
26	2	005500000	SCREW HX HD 1/4-20UNC X 3/4 LG
27	1	370005000	EXTENSION LOCK PAD
28	2	005901000	SCREW HX HD 1/4-20UNC X 1/2 LG
29	1	330421000	SHAFT 2403 TURNER
30	1	370880000	QUILL WELDMENT
31	2	330485000	BEARING, CONE
32	2	330486000	SEAL, OIL
33	1	330472000	CUP HOUSING W/CUPS
34	1	330483000	SPACER
35	1	019000000	NUT HEX 0.8750-14 UNF NYLON LOCK
36	1	330504000	MOUNT, MOTOR
37	3	330389000	SCREW, FLT HD 1/4-20UNC 3/4LG GR8
38	4	011510000	SCREW HX 1/2 NC X 1 1/4
39	4	017701000	NUT HX 1/2-13UNC
40	1	370875000	ECONO-TON IIR RELAY PANEL ASS'Y

ECONO-TON IIR GENERAL ASSEMBLY 7' BOOM STD PEDESTAL – P/N:370871000

ITEM NO.	QTY.	PART NO.	DESCRIPTION
41	4	005611000	SCREW HX 1/4 NC X 1
42	3	020400000	WASHER FL SAE 1/4
43	1	239300000	ZERK, GREASE
*44	1	370874000	KIT, ELECTRICAL ECONO-TON IIR
45	1	370413000	TRIGGER ASSY (ROTO-TON)
46	1	330313000	12VDC GEAR MOTOR
*47	1	370872000	DECAL KIT, 7'BOOM STD PED
*48	2	370875005	3/8 FEMALE QUICK DISCONNECT
49	1	370888000	PIN ASSY W/LANYARD 4.88 GRIP
50	1	370418001	GEAR, WORM 4-1/8" HOLE 5.00 B.C.
*51	1	370892000	SHIP KIT, ECONO-TON

*COMPONENTS NOT SHOWN IN LAYOUT

ECONO-TON IIR GENERAL ASSEMBLY 5' BOOM STD PEDESTAL – P/N:370871010

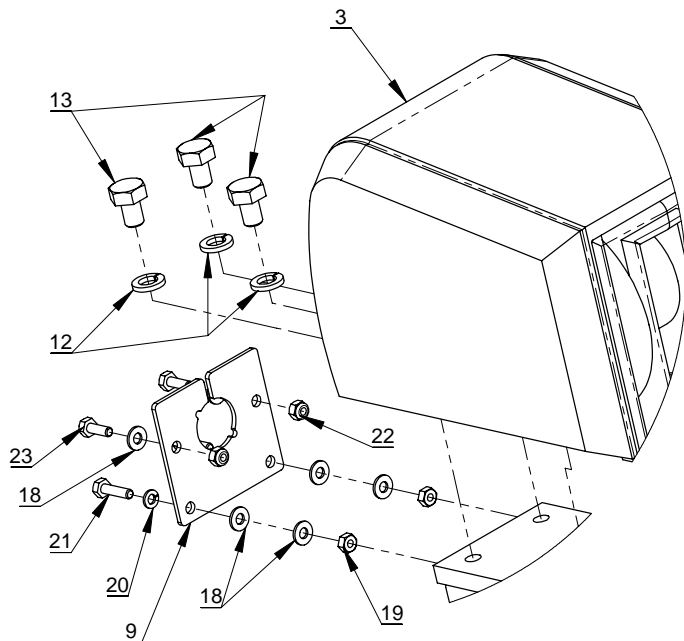

DETAIL B

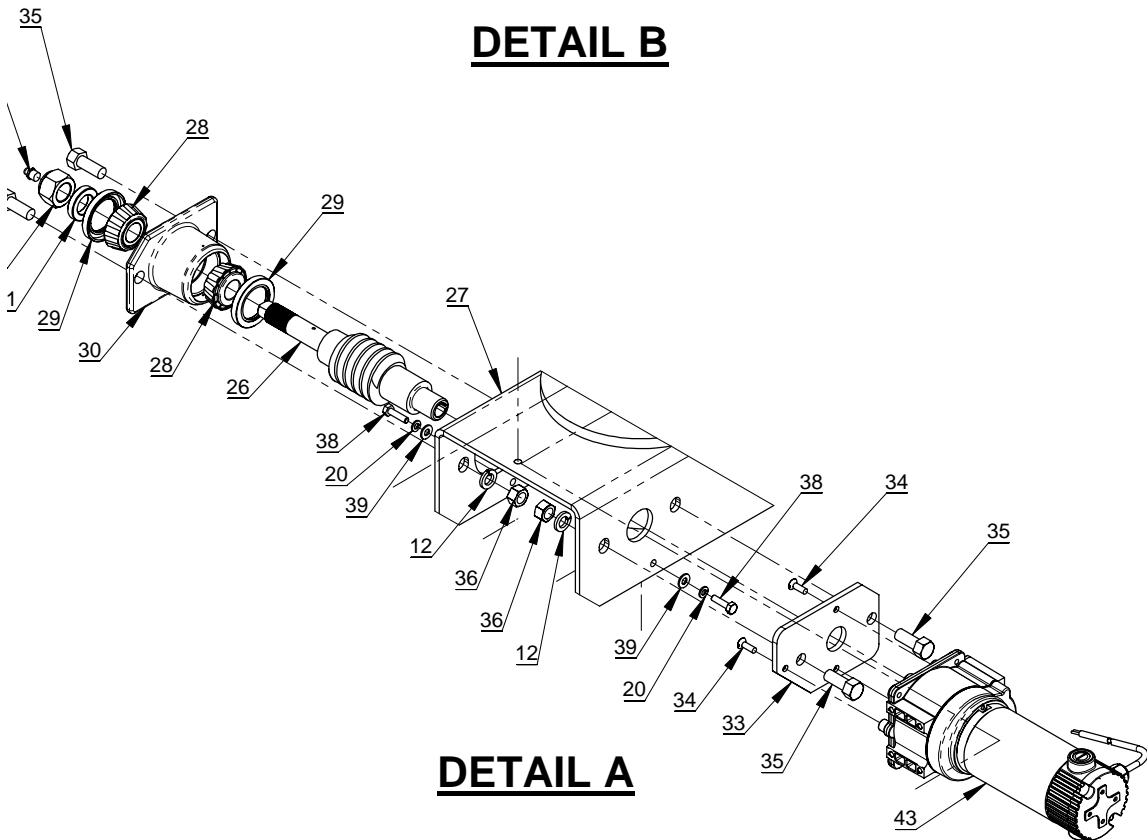

DETAIL A

ECONO-TON IIR GENERAL ASSEMBLY 5' BOOM STD PEDESTAL – P/N:370871010

ITEM NO.	QTY.	PART NO.	DESCRIPTION
1	1	330192000	BEARING, BALL
2	1	370034000	BEARING, RACE
3	1	370877000	WINCH ASS'Y 12 VOLTS DC
4	1	370033000	BEARING, NEEDLE ROLLER
5	1	370882000	SCREW, HEX HD 3/4-5-1/2" LG GR 5
6	1	370893000	SHEAVE ASSEMBLY (BEARING ONLY 370893002)
7	1	370878000	QUILL HOUSING (MACHINED)
8	1	370002000	PIN, LOCKING
9	1	370886001	MOUNT. RECEPTACLE
10	1	370186000	GROMMET WIRE-GUIDE
11	1	018600000	NUT HX NYLK 3/4-16UNF CP
12	7	021500000	WASHER SP LK 1/2
13	3	010000000	SCREW HEX HD 1/2-13UNC X 3/4LG GR 5
14	1	022102000	WASHER FL 3/4
15	4	370878005	SCREW, SOC HD 1/2'-13UNC 2-1/4"LG
16	1	370893004	SCREW, HEX HD 3/4-16UNF 2 LG GR 5
17	1	370893003	NUT HEX 3/4-16UNF THIN NYLOCK GR5
18	6	020300000	WASHER FL 1/4
19	3	015900000	NUT HX 1/4-20UNC SS
20	7	020200000	WASHER SP LK 1/4
21	2	005604000	SCREW HX HD 1/4-20UNC X 1 LG
22	2	016300000	NUT HX NYLK 1/4-20UNC
23	2	005500000	SCREW HX HD 1/4-20UNC X 3/4 LG
24	1	370005000	EXTENSION LOCK PAD
25	2	005901000	SCREW HX HD 1/4-20UNC X 1/2 LG
26	1	330421000	SHAFT 2403 TURNER
27	1	370880000	QUILL WELDMENT
28	2	330485000	BEARING, CONE
29	2	330486000	SEAL, OIL
30	1	330472000	CUP HOUSING W/CUPS
31	1	330483000	SPACER
32	1	019000000	NUT HEX 0.8750-14 UNF NYLON LOCK
33	1	330504000	MOUNT, MOTOR
34	3	330389000	SCREW, FLT HD 1/4-20UNC 3/4LG GR8
35	4	011510000	SCREW HX 1/2 NC X 1 1/4
36	4	017701000	NUT HX 1/2-13UNC
37	1	370875000	ECONO-TON IIR RELAY PANEL ASS'Y
38	4	005611000	SCREW HX 1/4 NC X 1
39	3	020400000	WASHER FL SAE 1/4
40	1	239300000	ZERK, GREASE

ECONO-TON IIR GENERAL ASSEMBLY 5' BOOM STD PEDESTAL – P/N:370871010

ITEM NO.	QTY.	PART NO.	DESCRIPTION
*41	1	370874000	KIT, ELECTRICAL ECONO-TON IIR
42	1	370413000	TRIGGER ASSY (ROTO-TON)
43	1	330313000	12VDC GEAR MOTOR
*44	2	370875005	3/8 FEMALE QUICK DISCONNECT
45	1	370888000	PIN ASSY W/LANYARD 4.88 GRIP
46	1	370418001	GEAR, WORM 4-1/8" HOLE 5.00 B.C.
*47	1	370892000	SHIP KIT, ECONO-TON
48	1	370881010	PEDESTAL BASE WELD - 5' BOOM
49	1	370883010	LOWER BOOM WELDMENT 5' BOOM
50	1	370884010	UPPER BOOM WELDMENT 5' BOOM
*51	1	370872010	DECAL KIT, 5' BOOM STD PED

*COMPONENTS NOT SHOWN IN LAYOUT

ECONO-TON IIR GENERAL ASSEMBLY 7' BOOM SHORT PEDESTAL- P/N:370871020

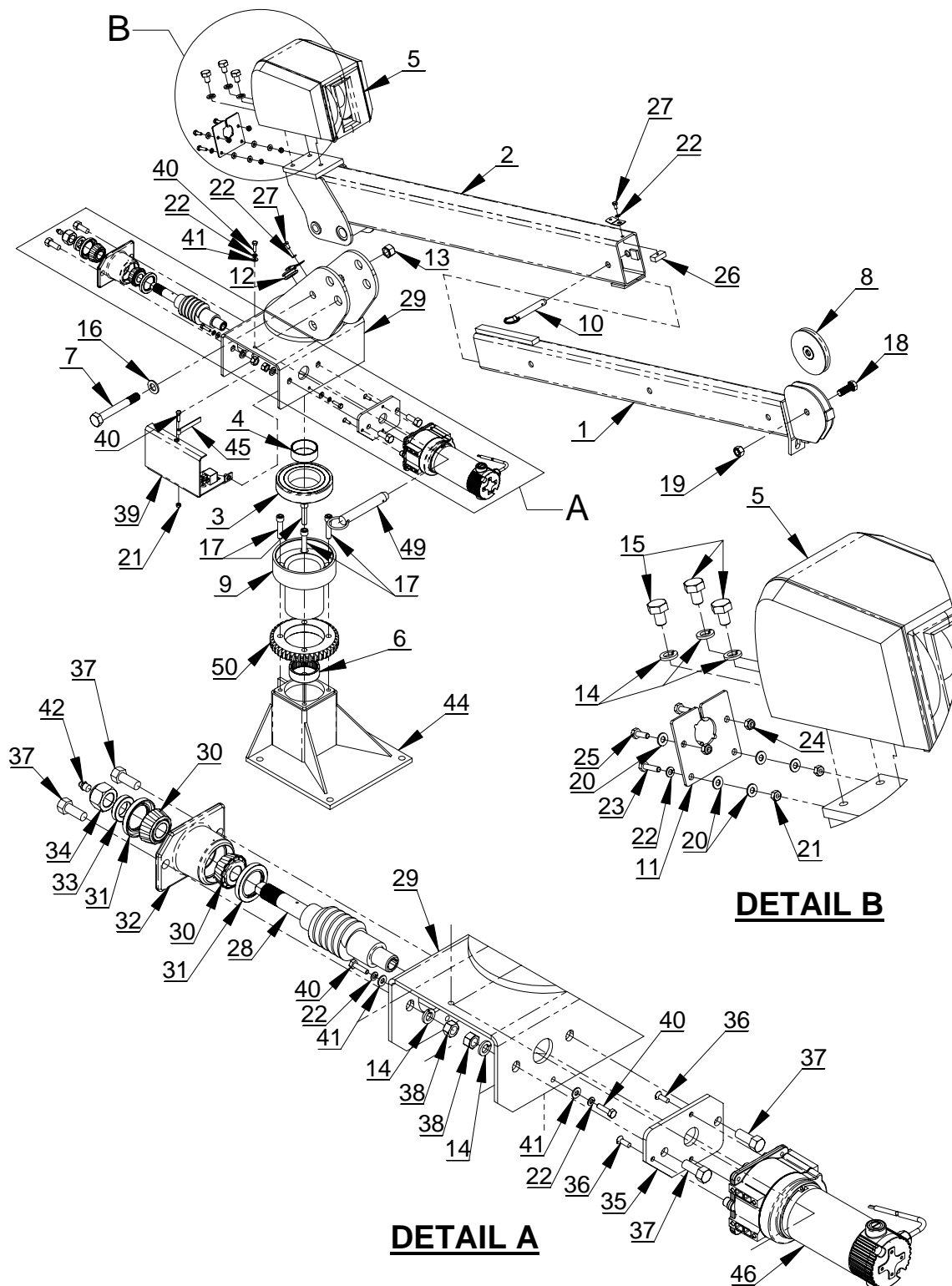

ECONO-TON IIR GENERAL ASSEMBLY 7' BOOM SHORT PEDESTAL- P/N:370871020

ITEM NO.	QTY.	PART NO.	DESCRIPTION
1	1	370884000	UPPER BOOM WELDMENT 7' BOOM
2	1	370883000	LOWER BOOM WELDMENT 7' BOOM
3	1	330192000	BEARING, BALL
4	1	370034000	BEARING, RACE
5	1	370877000	WINCH ASS'Y 12 VOLTS DC
6	1	370033000	BEARING, NEEDLE ROLLER
7	1	370882000	SCREW, HEX HD 3/4-5-1/2" LG GR 5
8	1	370893000	SHEAVE ASSEMBLY (BEARING ONLY 370893002)
9	1	370878000	QUILL HOUSING (MACHINED)
10	1	370002000	PIN, LOCKING
11	1	370886001	MOUNT. RECEPTACLE
12	1	370186000	GROMMET WIRE-GUIDE
13	1	018600000	NUT HX NYLK 3/4-16UNF CP
14	7	021500000	WASHER SP LK 1/2
15	3	010000000	SCREW HEX HD 1/2-13UNC X 3/4LG GR 5
16	1	022102000	WASHER FL 3/4
17	4	370878005	SCREW, SOC HD 1/2'-13UNC 2-1/4"LG
18	1	370893004	SCREW, HEX HD 3/4-16UNF 2 LG GR 5
19	1	370893003	NUT HEX 3/4-16UNF THIN NYLOCK GR5
20	6	020300000	WASHER FL 1/4
21	3	015900000	NUT HX 1/4-20UNC SS
22	7	020200000	WASHER SP LK 1/4
23	2	005604000	SCREW HX HD 1/4-20UNC X 1 LG
24	2	016300000	NUT HX NYLK 1/4-20UNC
25	2	005500000	SCREW HX HD 1/4-20UNC X 3/4 LG
26	1	370005000	EXTENSION LOCK PAD
27	2	005901000	SCREW HX HD 1/4-20UNC X 1/2 LG
28	1	330421000	SHAFT 2403 TURNER
29	1	370880000	QUILL WELDMENT
30	2	330485000	BEARING, CONE
31	2	330486000	SEAL, OIL
32	1	330472000	CUP HOUSING W/CUPS
33	1	330483000	SPACER
34	1	019000000	NUT HEX 0.8750-14 UNF NYLON LOCK
35	1	330504000	MOUNT, MOTOR
36	3	330389000	SCREW, FLT HD 1/4-20UNC 3/4LG GR8
37	4	011510000	SCREW HX 1/2 NC X 1 1/4
38	4	017701000	NUT HX 1/2-13UNC
39	1	370875000	ECONO-TON IIR RELAY PANEL ASS'Y
40	4	005611000	SCREW HX 1/4 NC X 1

ECONO-TON IIR GENERAL ASSEMBLY 7' BOOM SHORT PEDESTAL – P/N:370871020

ITEM NO.	QTY.	PART NO.	DESCRIPTION
41	3	020400000	WASHER FL SAE 1/4
42	1	239300000	ZERK, GREASE
*43	1	370874000	KIT, ELECTRICAL ECONO-TON IIR
44	1	370881020	PEDESTAL BASE WELD - SHORT PED
45	1	370413000	TRIGGER ASSY (ROTO-TON)
46	1	330313000	12VDC GEAR MOTOR
*47	2	370875005	3/8 FEMALE QUICK DISCONNECT
*48	1	370872020	DECAL KIT, 7' BOOM SHORT PED.
49	1	370888000	PIN ASSY W/LANYARD 4.88 GRIP
50	1	370418001	GEAR, WORM 4-1/8" HOLE 5.00 B.C.
*51	1	370892000	SHIP KIT, ECONO-TON

* COMPONENTS NOT SHOWN ON LAYOUT

ECONO-TON IIR GENERAL ASSEMBLY 5' BOOM SHORT PEDESTAL- P/N:370871030

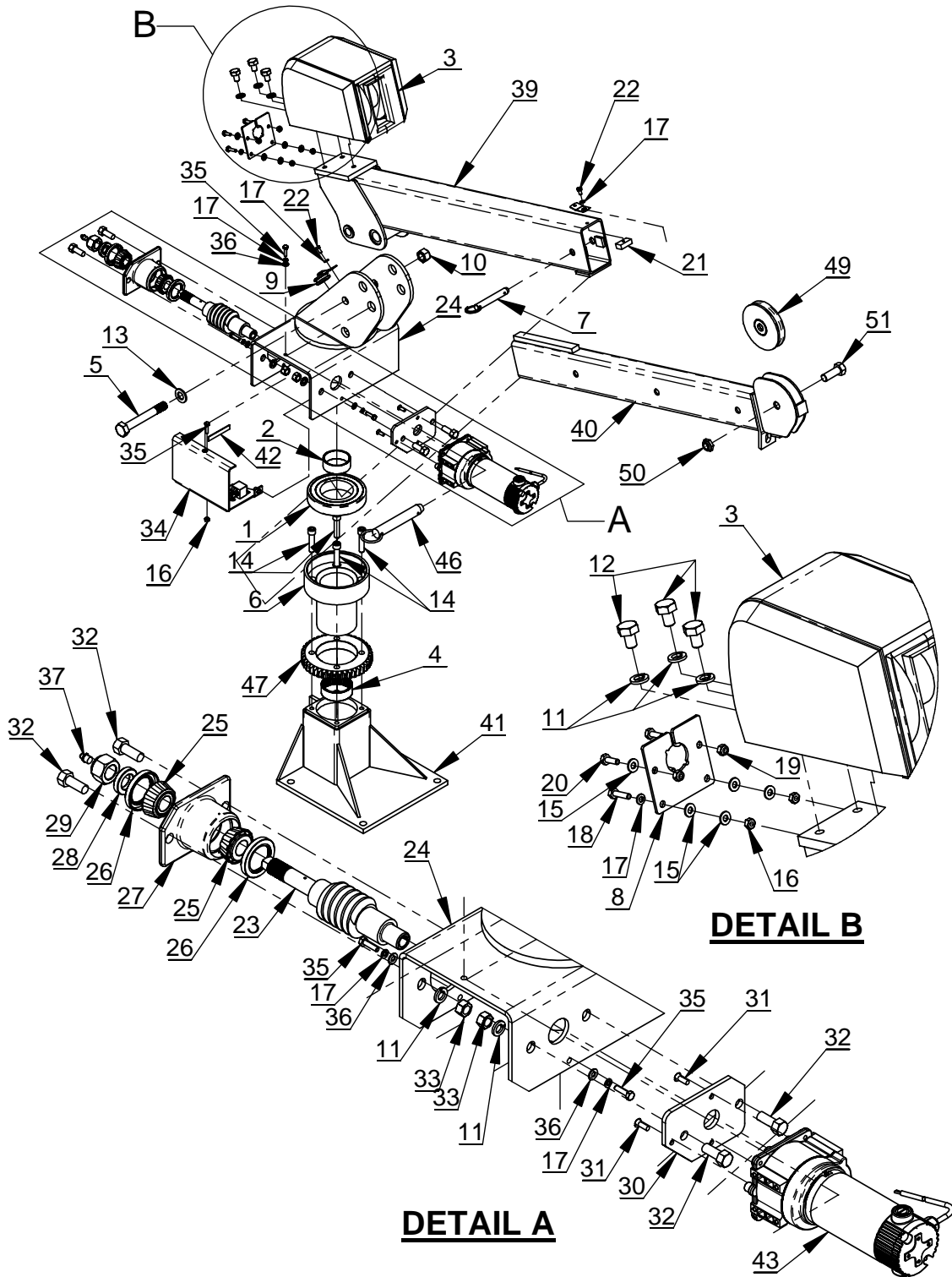

ECONO-TON IIR GENERAL ASSEMBLY 5' BOOM SHORT PEDESTAL- P/N:370871030

ITEM NO.	QTY.	PART NO.	DESCRIPTION
1	1	330192000	BEARING, BALL
2	1	370034000	BEARING, RACE
3	1	370877000	WINCH ASS'Y 12 VOLTS DC
4	1	370033000	BEARING, NEEDLE ROLLER
5	1	370882000	SCREW, HEX HD 3/4-5-1/2" LG GR 5
6	1	370878000	QUILL HOUSING (MACHINED)
7	1	370002000	PIN, LOCKING
8	1	370886001	MOUNT. RECEPTACLE
9	1	370186000	GROMMET WIRE-GUIDE
10	1	018600000	NUT HX NYLK 3/4-16UNF CP
11	7	021500000	WASHER SP LK 1/2
12	3	010000000	SCREW HEX HD 1/2-13UNC X 3/4LG GR 5
13	1	022102000	WASHER FL 3/4
14	4	370878005	SCREW, SOC HD 1/2'-13UNC 2-1/4"LG
15	6	020300000	WASHER FL 1/4
16	3	015900000	NUT HX 1/4-20UNC SS
17	7	020200000	WASHER SP LK 1/4
18	2	005604000	SCREW HX HD 1/4-20UNC X 1 LG
19	2	016300000	NUT HX NYLK 1/4-20UNC
20	2	005500000	SCREW HX HD 1/4-20UNC X 3/4 LG
21	1	370005000	EXTENSION LOCK PAD
22	2	005901000	SCREW HX HD 1/4-20UNC X 1/2 LG
23	1	330421000	SHAFT 2403 TURNER
24	1	370880000	QUILL WELDMENT
25	2	330485000	BEARING, CONE
26	2	330486000	SEAL, OIL
27	1	330472000	CUP HOUSING W/CUPS
28	1	330483000	SPACER
29	1	019000000	NUT HX NYLK 7/8-14UNF
30	1	330504000	MOUNT, MOTOR
31	3	330389000	SCREW, FLT HD 1/4-20UNC 3/4LG GR8
32	4	011510000	SCREW HX 1/2 NC X 1 1/4
33	4	017701000	NUT HX 1/2-13UNC
34	1	370875000	ECONO-TON IIR RELAY PANEL ASS'Y
35	4	005611000	SCREW HX 1/4 NC X 1
36	3	020400000	WASHER FL SAE 1/4
*37	1	239300000	ZERK, GREASE
38	1	370874000	KIT, ELECTRICAL ECONO-TON IIR
39	1	370883010	LOWER BOOM WELDMENT 5' BOOM
40	1	370884010	UPPER BOOM WELDMENT 5' BOOM

**ECONO-TON IIR GENERAL ASSEMBLY
5' BOOM SHORT PEDESTAL- P/N:370871030**

ITEM NO.	QTY.	PART NO.	DESCRIPTION
41	1	370881020	PEDESTAL BASE WELD - SHORT PED
42	1	370413000	TRIGGER ASSY (ROTO-TON)
43	1	330313000	12VDC GEAR MOTOR
*44	2	370875005	3/8 FEMALE QUICK DISCONNECT
*45	1	370872030	DECAL KIT, 5' BOOM SHORT PED
46	1	370888000	PIN ASSY W/LANYARD 4.88 GRIP
47	1	370418001	GEAR, WORM 4-1/8" HOLE 5.00 B.C.
*48	1	370892000	SHIP KIT, ECONO-TON
49	1	370893000	SHEAVE ASS'Y (BEARING ONLY 370893002)
50	1	370893003	NUT, HEX NYLOCK THIN 3/4
51	1	370893004	BOLT, HEX 3/4-16UNF 2"LG

* COMPONENTS NOT SHOWN ON LAYOUT

ECONO-TON II

WINCH ASSEMBLY - P/N: 370877000

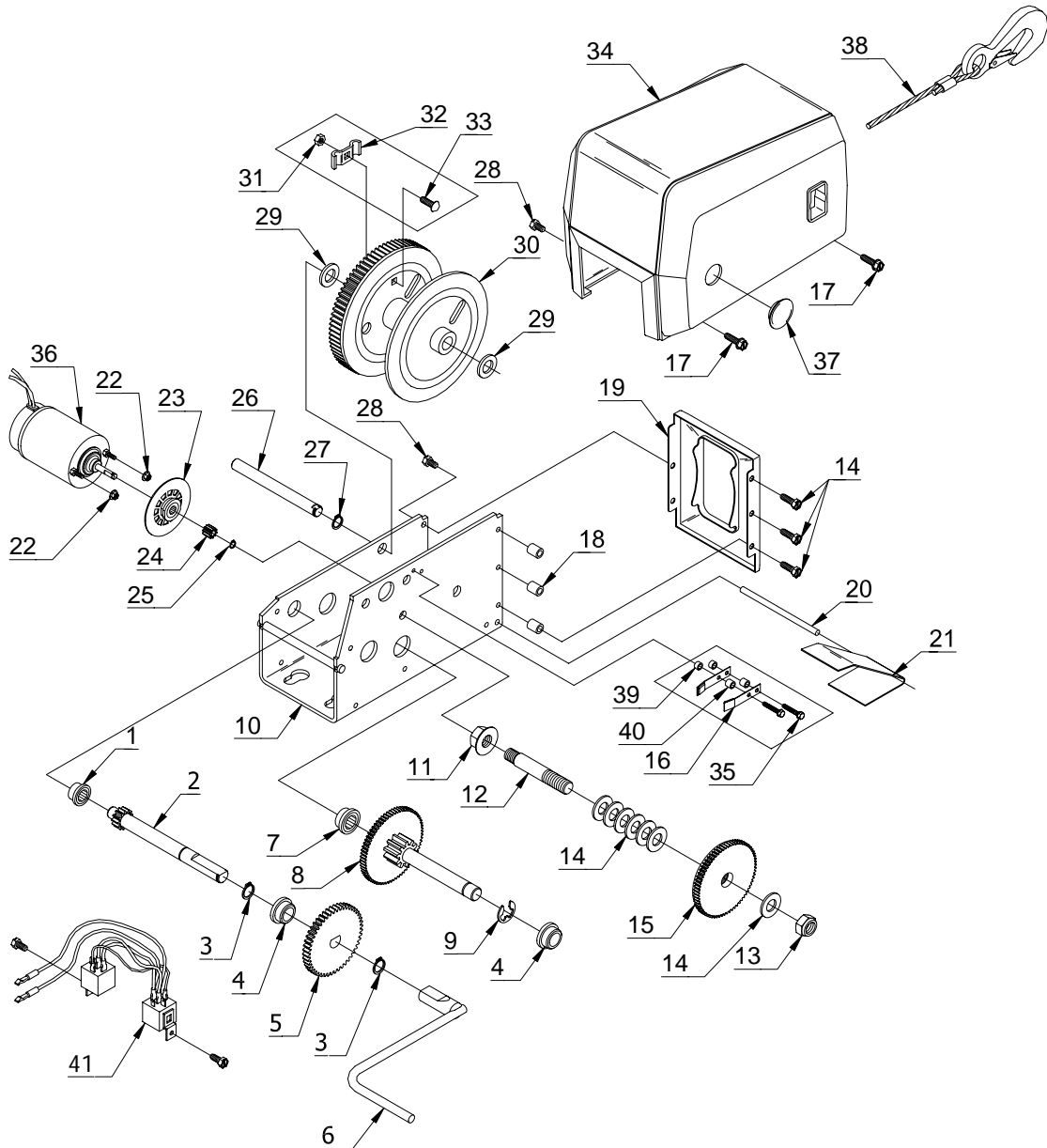

ECONO-TON II

WINCH ASSEMBLY - P/N: 370877000

ITEM NO.	QTY.	PART NO.	DESCRIPTION
1	1	272500000	BEARING HOUSING ASSEMBLY
2	1	272151000	PRIMARY DRIVE SHAFT ASSEMBLY
3	2	272152000	RETAINING RING
4	2	272153000	BUSHING
5	1	272154000	GEAR 56 T
6	1	272155000	HANDLE ASSEMBLY
7	1	272501000	DRIVE SHAFT BEARING HOUSING ASSEMBLY
8	1	272158000	INTERMEDIATE DRIVE SHAFT ASSEMBLY
9	1	272159000	"E" RING
10	1	272160000	BASE
11	1	330011000	NUT HX LK 7/16 NF
12	1	330012000	CLUTCH STUD
13	1	330018000	NUT LK 1/2
14	7	272502000	WASHER
15	1	330015000	GEAR ASSEMBLY
16	2	272434000	BRAKE SPRING ASSEMBLY
17	5	272162000	SCREW 1/4 NC X 1 1/16
18	3	272163000	SPACER
19	1	272164000	FRONT PLATE
20	1	272165000	LEVEL WIND PIN
21	1	330019000	LEVEL WIND
22	2	330022000	NUT HX LK #10 NF
23	1	272433000	BRAKE DISC ASSEMBLY
24	1	272170000	12 T PINION GEAR
25	1	272171000	"E" RING
26	1	272173000	REEL SHAFT
27	1	272174000	RETAINING RING
28	4	272175000	SCREW 1/4 NC X 3/4
29	2	272176000	WASHER
30	1	272503000	REEL ASSEMBLY
31	1	272179000	NUT HX 1/4 NC
32	1	272180000	ROPE CLAMP
33	1	272504000	CARRAGE BOLT 1/4 NC X 3/4
34	1	272505000	COVER
35	2	272437000	SCREW #10 NF X 1
36	1	272184000	MOTOR ASSEMBLY
37	1	272508000	COVER PLUG
38	1	370876003	CABLE & HOOK (1/4 X 25")
39	2	272435000	SPACER
40	2	272436000	BRAKE SPRING SPACER
41	2	370875004	60/80 AMP RELAY

ECONO-TON IIR

ELECTRICAL SCHEMATIC - P/N: 370887001

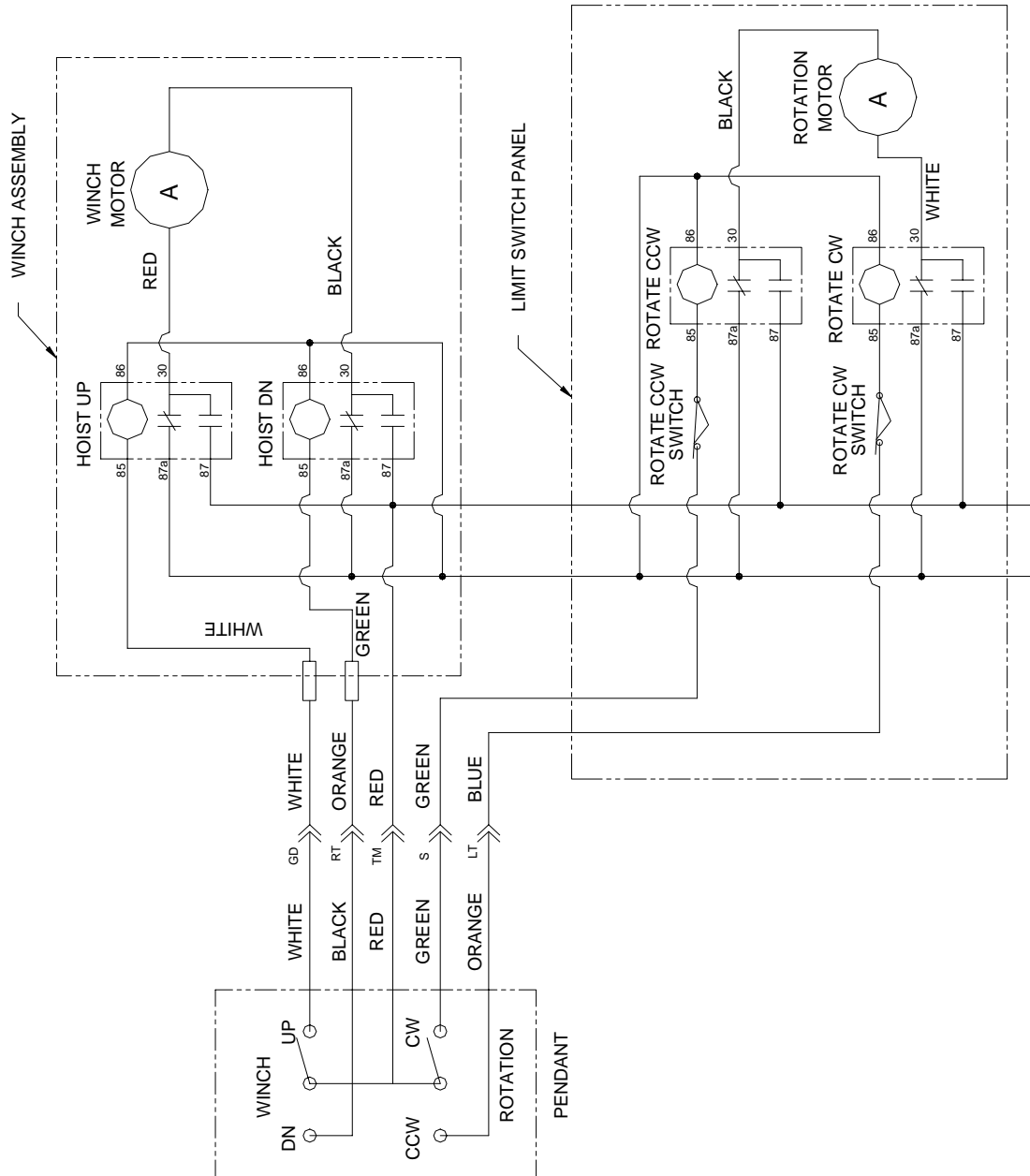

ECONO-TON IIR ELECTRICAL WIRING LAYOUT

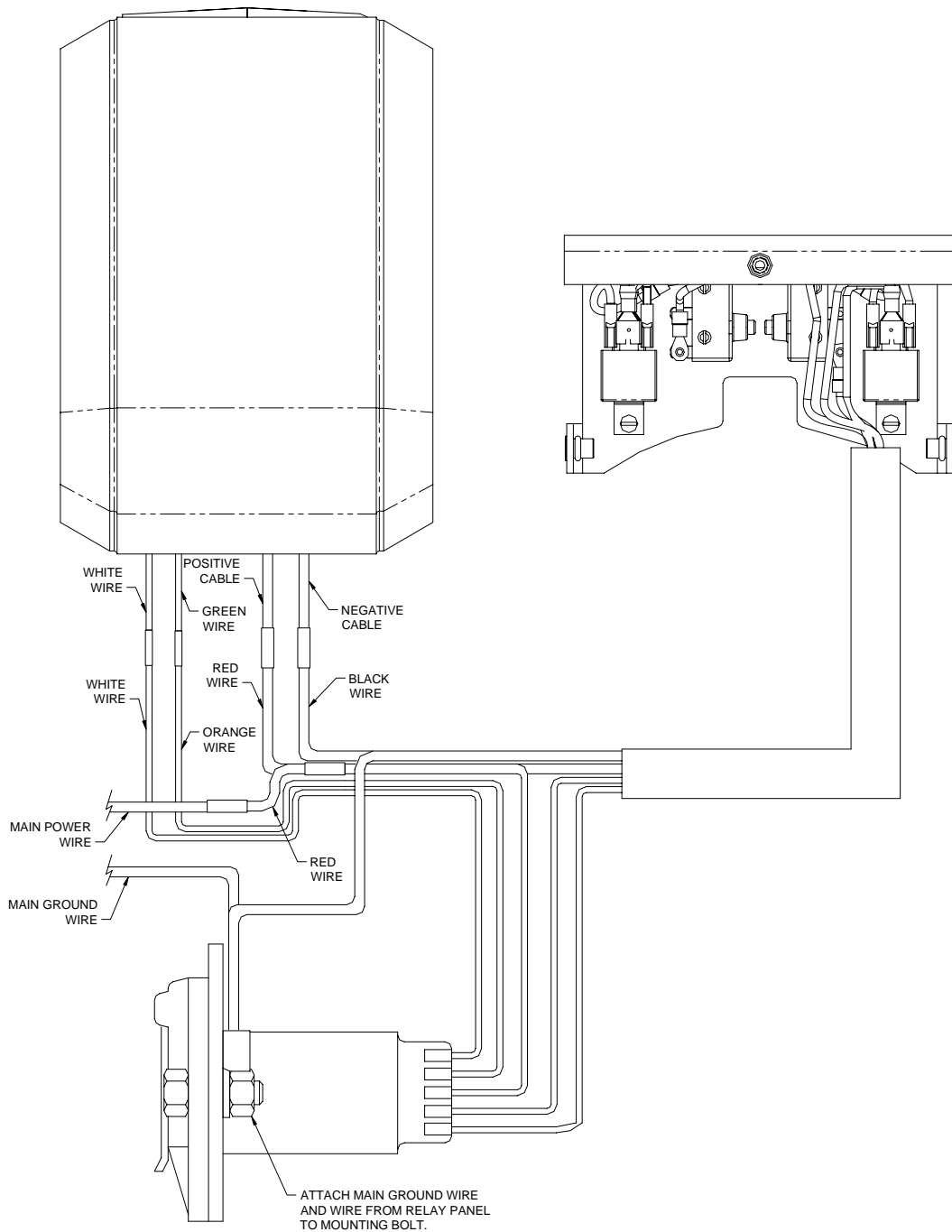

NOTES

ECONO-TON IIR RELAY PANEL ASSEMBLY - P/N: 370875000

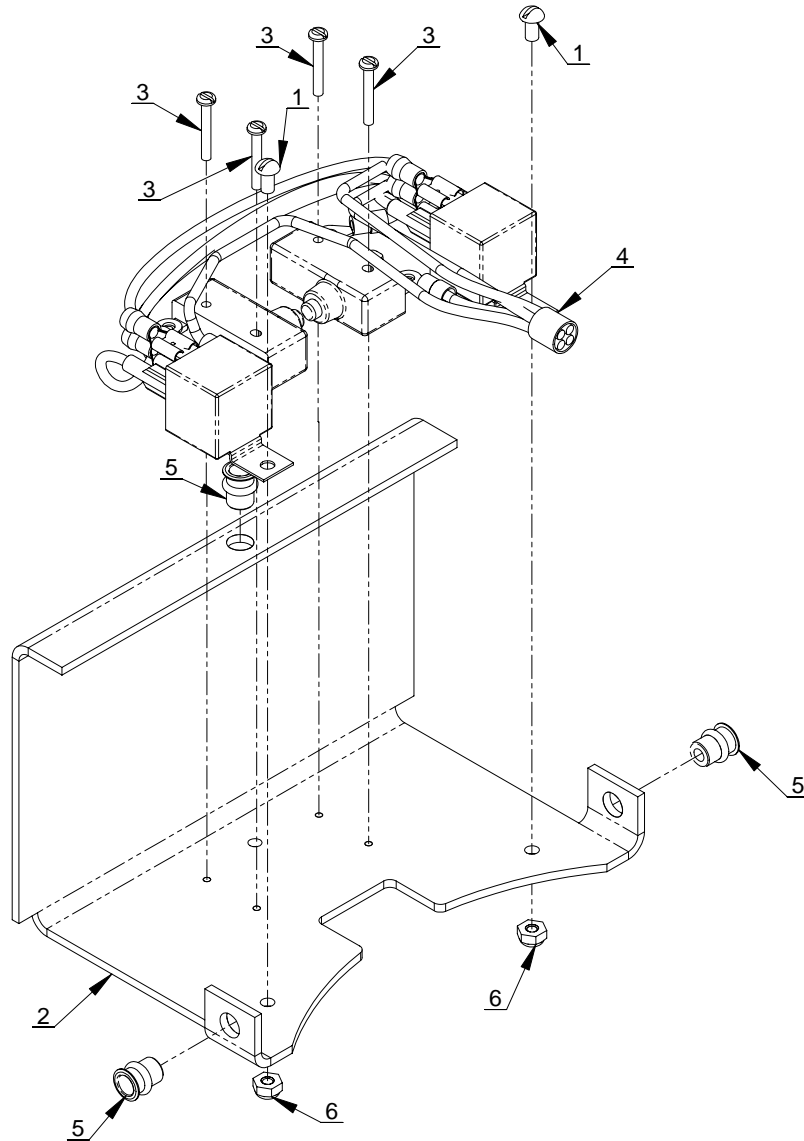

ITEM NO.	QTY.	PART NO.	DESCRIPTION
1	2	001900000	SCREW RD HD #10-32UNF X 3/8 LG
2	1	370875002	ECONO-TON IIR RELAY PANEL
3	4	000602000	SCREW PN #6 NC X 1
4	1	370875001	ECONO-TON IIR WIRING HARNESS
5	3	736272000	NUTSERT 1/4-20UNC X .027-.165 GRIP
6	2	015801000	NUT HX NYLK #10-24UNC ZP

ECONO-TON IIR

RELAY PANEL HARNESS - P/N: 370875001

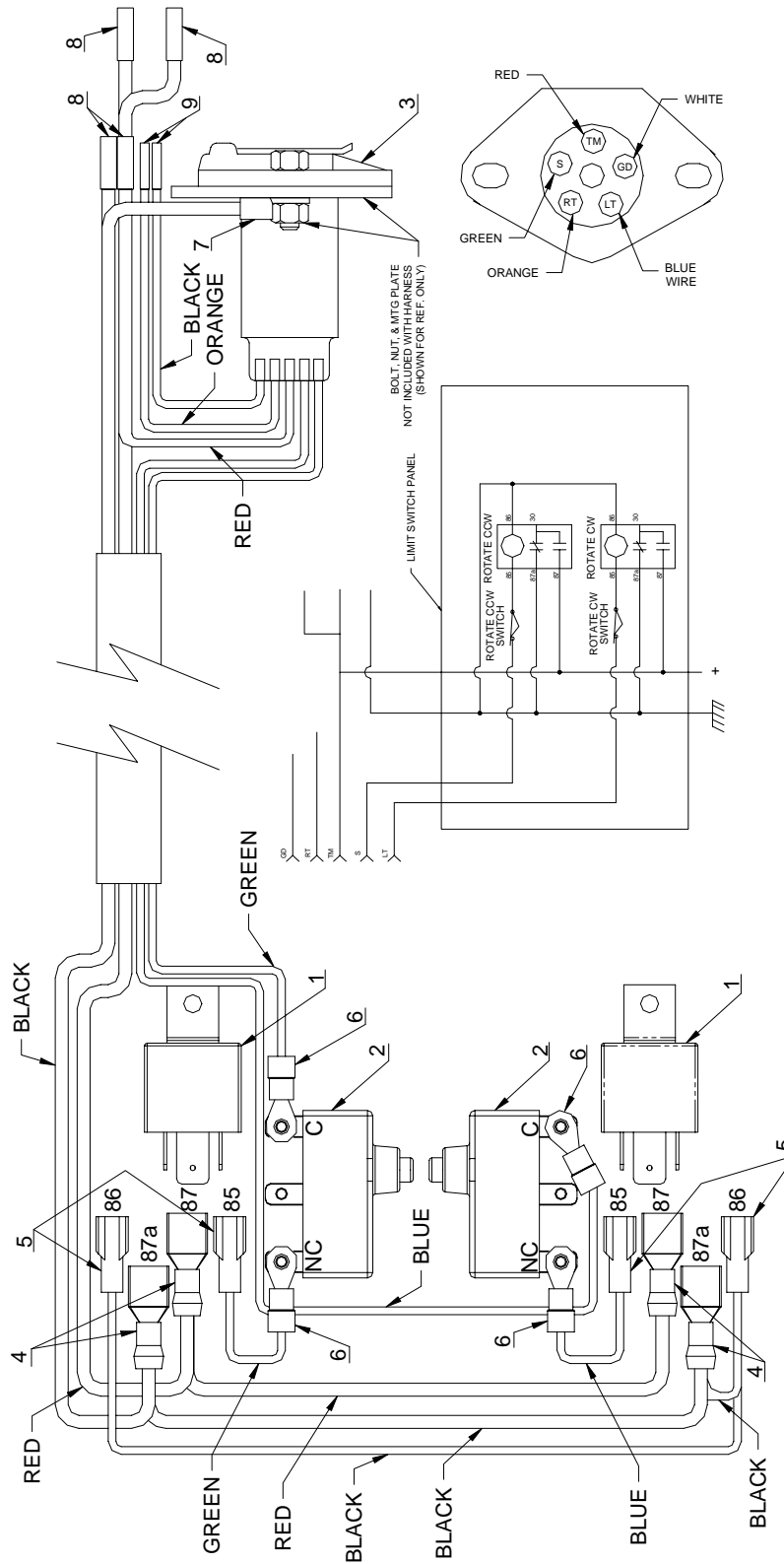

ECONO-TON IIR
RELAY PANEL HARNESS - P/N: 370875001

ITEM NO.	QTY.	PART NO.	DESCRIPTION
1	2	370875004	RELAY 80/60 AMP PCB POWER RELAY
2	2	370419000	LIMIT SWITCH
3	1	642801000	6-PIN SOCKET
4	4	370875005	3/8in FEMALE SPADE CONNECTOR
5	4	320356000	1/4in FEMALE SPADE CONNECTOR
6	4	001000000	TERMINAL RING #8 12GA
7	1	002004000	TERMINAL RING 8GA
8	4	330054000	BUTT SPLICE 8GA
9	2	000302000	BUTT SPLICE 14GA

NOTES

ECONO-TON IIR

PENDANT ASSEMBLY - P/N: 370885000

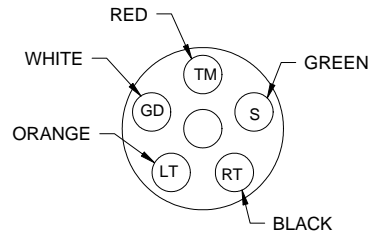
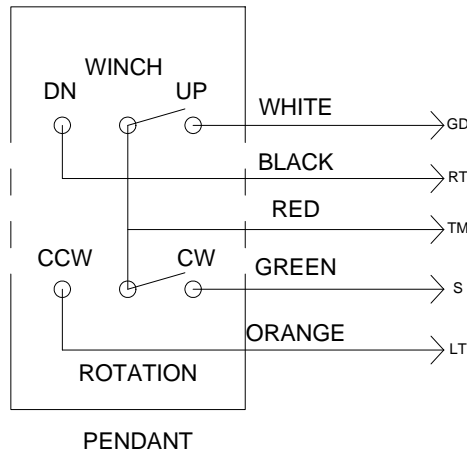
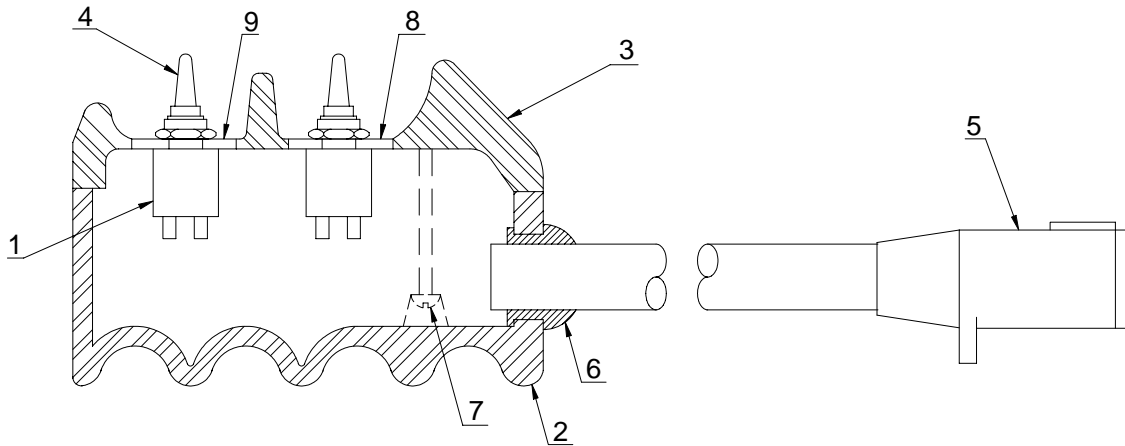

ITEM NO.	QTY.	PART NO.	DESCRIPTION
1	2	622000000	TOGGLE SWITCH
2	1	370130000	PENDANT HOUSING BOTTOM
3	1	370131000	PENDANT HOUSING TOP
4	2	640300000	TOGGLE SWITCH BOOT
5	1	642802000	PENDANT PLUG
6	1	370132000	PENDANT HOUSING GASKET
7	1	001207000	SCREW #8 NC X 1
8	1	370202000	DECAL HOIST UP/DOWN
9	1	370203000	DECAL ROTATION CW/CCW

ECONO-TON II/R

LOAD CHART 7' BOOM - P/N: 370873000

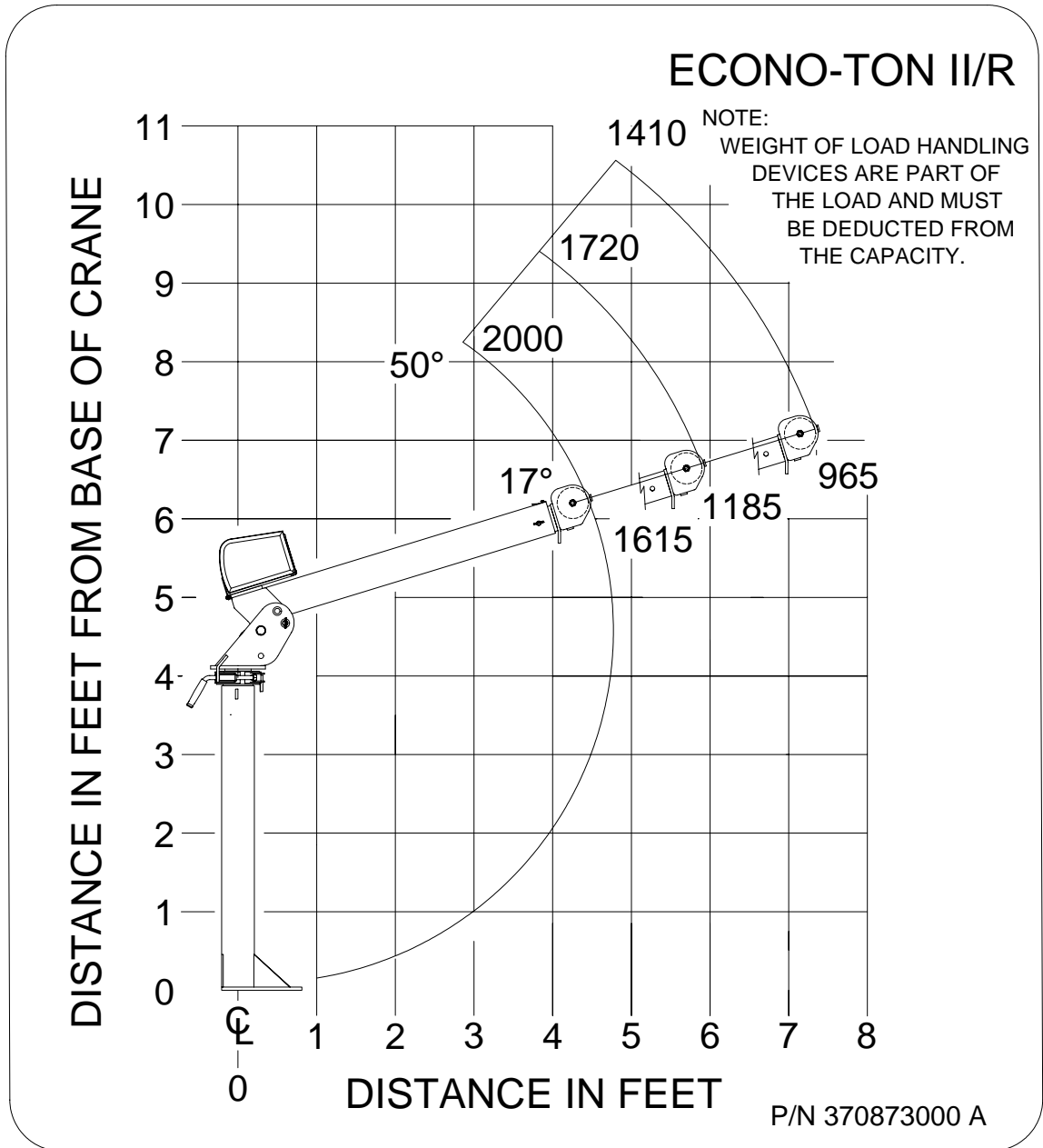

ECONO-TON II/R

LOAD CHART 5' BOOM - P/N: 370873010

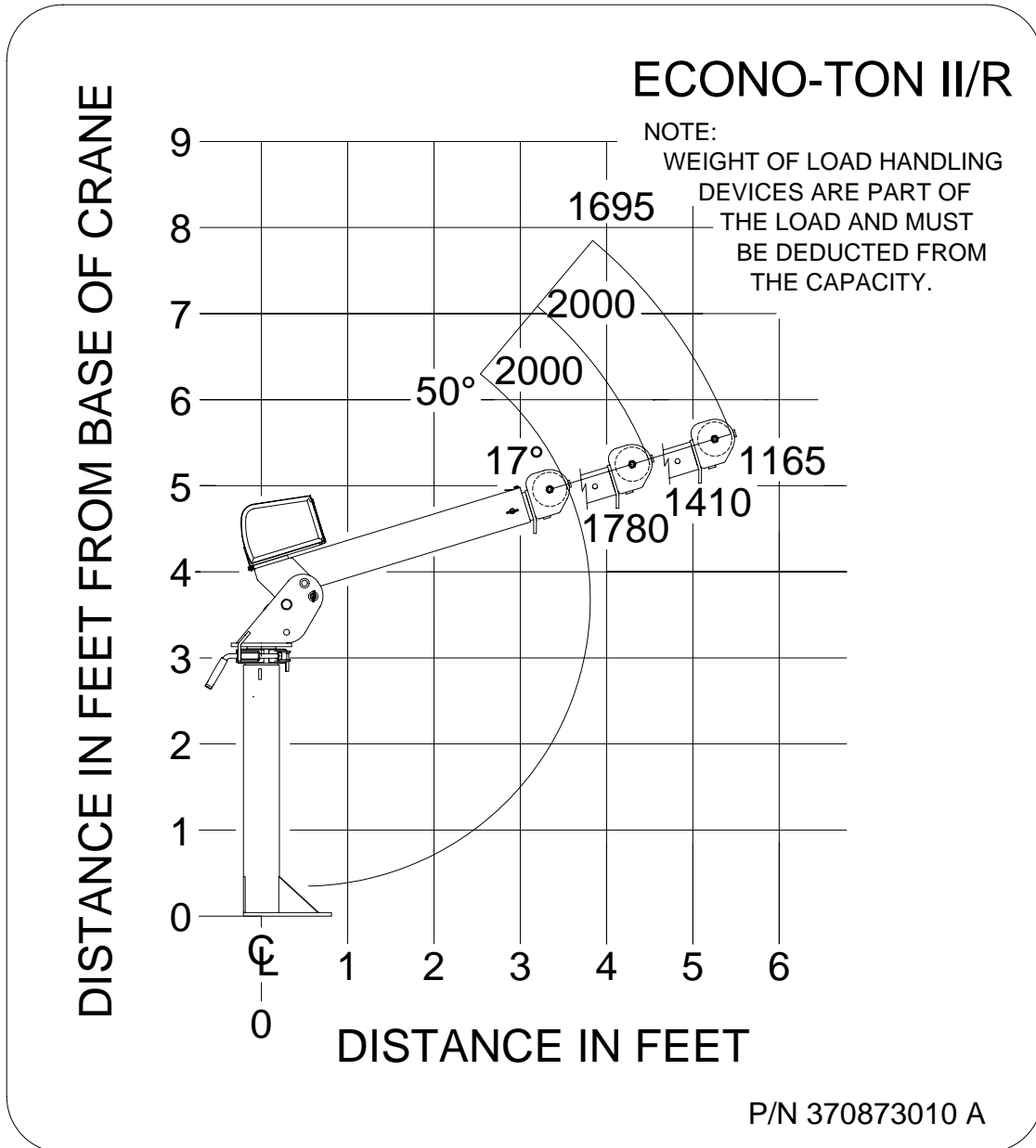

ECONO-TON II/R

LOAD CHART 7' BOOM SHORT PEDESTAL

P/N: 370873020

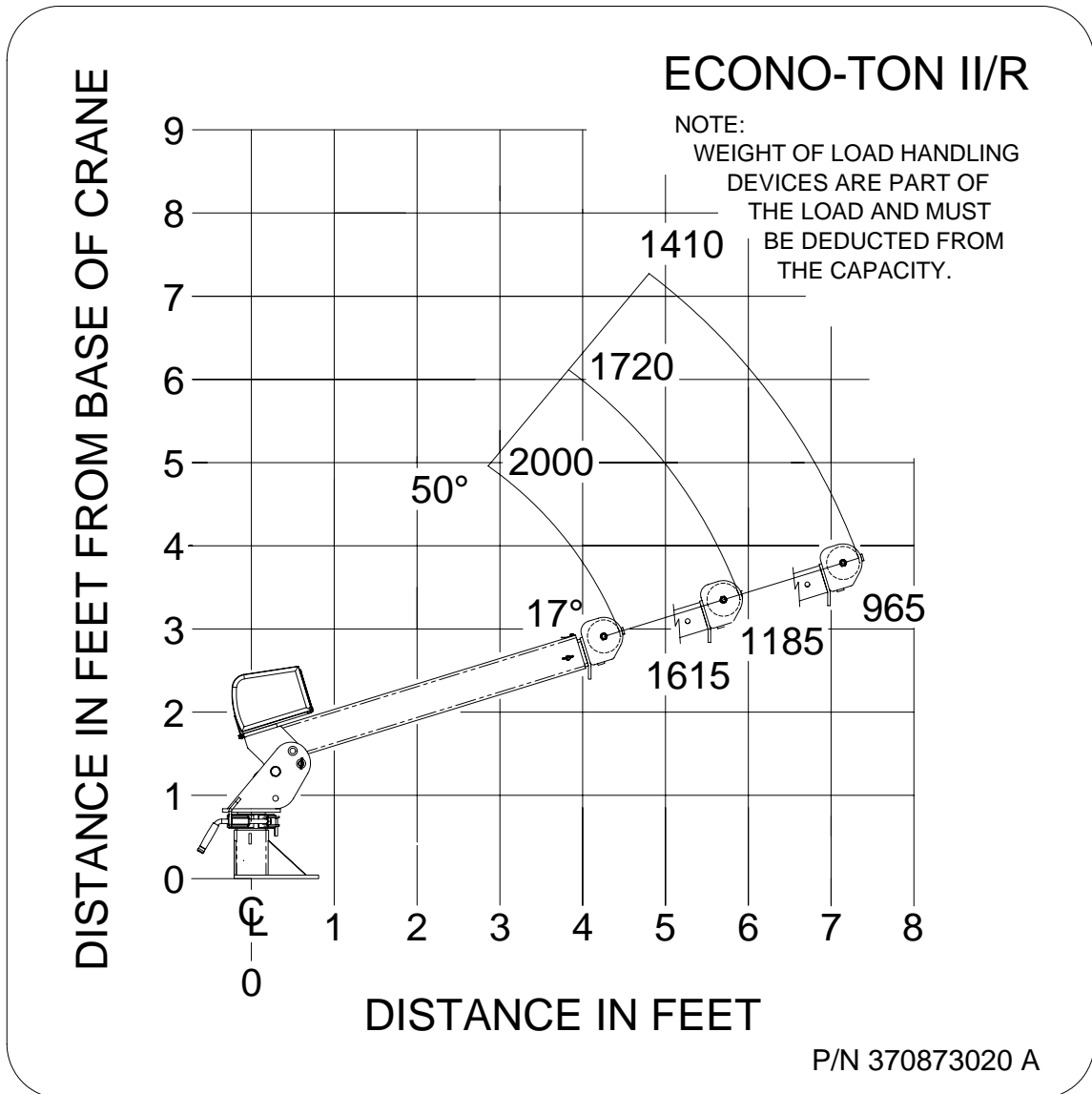

ECONO-TON II/R
LOAD CHART 5' BOOM SHORT PEDESTAL
P/N: 370873030

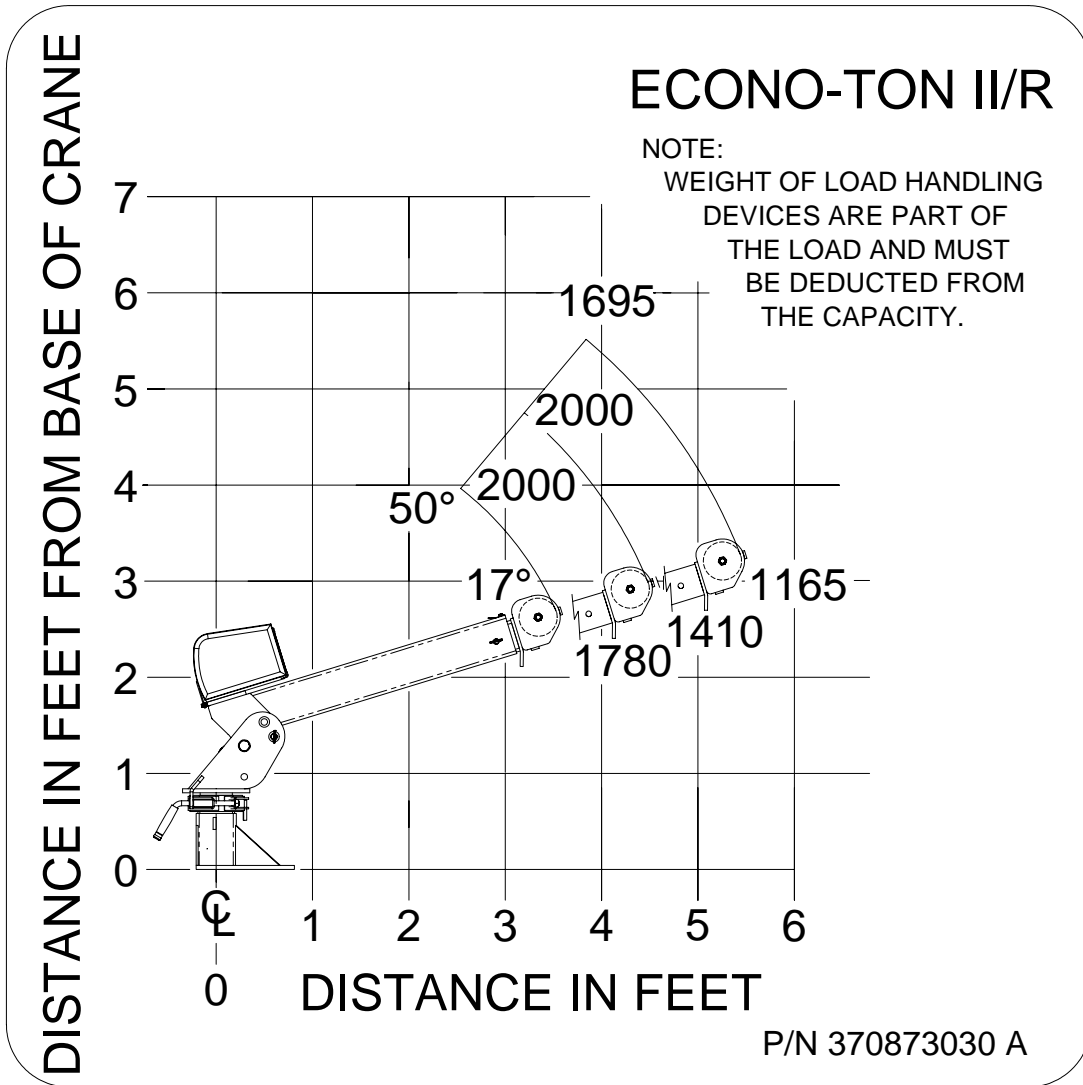

CRANE PREVENTATIVE MAINTENANCE

PAINT FINISH PREVENTIVE MAINTENANCE INSTRUCTIONS

The paint finish on Auto Crane products can become damaged during normal use when chipped, scratched, exposed to harsh chemicals, cleaned with high pressure washers, etc. During periods when the truck is exposed to salt or other corrosive chemicals, Auto Crane products should be washed weekly. The paint finish should be inspected when washed or at least monthly. Any exposed bare metal or visible rust should be repaired immediately. Damaged paint on cranes should be repaired by:

1. Sanding the damaged areas to bare metal.
2. Solvent cleaning the sanded areas to remove sanding residue. Wipe dry with a clean cloth to remove any remaining residue.
3. Priming the sanded areas to a minimum of a 2 mil dry film thickness per the primer manufacturer's instructions. The primer must be compatible with Sherwin Williams' E2W932 epoxy primer.
4. Applying a 2 mil dry film thickness top coat paint per the manufacturer's instructions within 24 hours of applying the primer. The top coat paint must be compatible with Sherwin Williams' E2W932 epoxy primer and Sherwin Williams' Genesis polyurethane top coat paint. The final primer and top coat should have approximately a 4 mil dry film thickness.

NOTES



P.O. Box 580697 * Tulsa, OK 74158-0697
4707 N. Mingo Rd. * Phone (918) 836-0463

LIMITED WARRANTY 2 YEAR PARTS AND LABOR

Auto Crane will warranty to the consumer for a period of (2) years parts and labor from the date of purchase. Each new Auto Crane unit they sell will be free under normal use and service from defects in material and workmanship. Date of purchase will be honored as the date indicated on the Bill of Sale, which must accompany the Warranty Registration and be on file with Auto Crane. Absent a valid Warranty Registration and appropriate documentation, the original date of manufacture, as indicated by the serial number on the product, will be used to determine the effective date of the 2 year warranty.

The obligation of Auto Crane under this warranty is limited to the replacement or repair of parts that appear to the manufacturer after review and/or inspection to be defective and paid flat rate labor for replacing defective parts. This warranty does not obligate Auto Crane to bear the travel time charges in connection with the replacement or repair of defective parts. Responsibility for customer's claims arising from misapplication, abuse, misuse or alteration of equipment or parts lies with the distributor or user and no warranty obligation is assumed in these circumstances by Auto Crane.

Auto Crane will in no event be liable for any consequential damages or contingent liabilities arising out of the failure of any Auto Crane Product or parts to operate properly.

Auto Crane makes no warranty in respect to component accessories, it being subject to the warranties of their respective manufacturers.

If field service, at the request of the distributor, is rendered and fault is found not to be with Auto Crane's product, the distributor shall pay the time and expense of the field representative.

Claims for service labor or other expenses that have incurred by the buyer without approval or authorization or Auto Crane will not be accepted.

When applying for warranty, claims may be handled by contacting your nearest authorized Auto Crane Distributor. All claims are to be filed in writing on an Auto Crane Warranty Claim Form.

AUTO CRANE COMPANY IS UNDER NO OBLIGATION TO EXTEND THIS WARRANTY TO ANY CUSTOMER FOR WHICH AN AUTO CRANE DELIVERY REPORT FORM HAS NOT BEEN COMPLETED AND ON FILE WITH AUTO CRANE COMPANY