

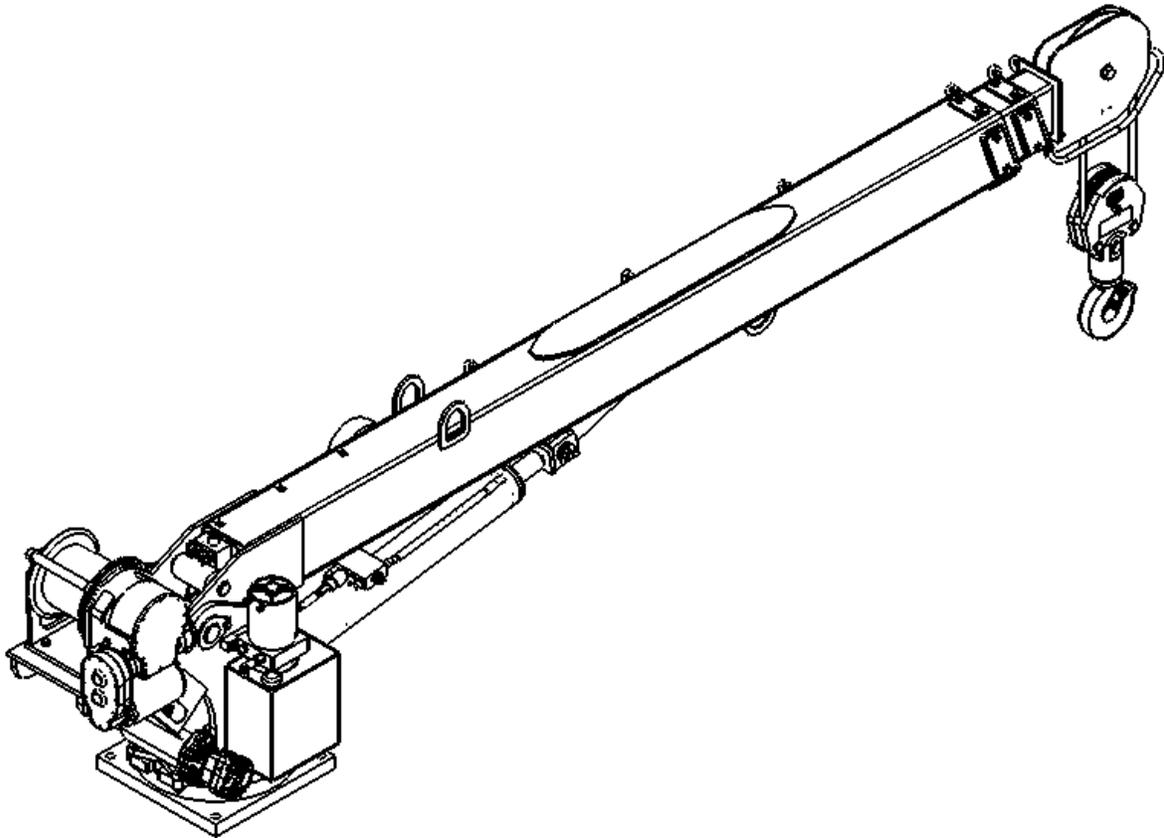

5005EH-24V CONTROL OWNERS MANUAL

Manual No. 99955001

Rev. 02/21/08



Serial No. _____

Mailing Address:
P.O. Box 580697
Tulsa, OK 74158-0697
Physical Address:
4707 N. Mingo Rd.
Tulsa, OK 74117-5904

Phone (918) 836-0463
Fax (918) 834-5979
<http://www.autocrane.com>



Auto Crane Warranty Registration

Fax Transmission

To: Warranty Department Fax: (918) 834-5979
 From: _____ Date: _____
 Re: Product Registration Pages: _____

End User Information: (Required for Warranty Activation)

Name: _____ Phone: _____
 Address: _____
 City: _____ State: _____ Zip: _____
 Contact: _____ E-mail Address: _____

Distributor Information: (Required for Warranty Activation)

Name: _____
 Address: _____
 City: _____ State: _____ Zip: _____
 Contact: _____ E-mail Address: _____

Product Information: (Required for Warranty Activation)

Model No.: _____ Serial No.: _____
 Date Product Delivered: _____ Date Processed:* _____
 VIN # _____ * For Auto Crane use only

ONE REGISTRATION FORM PER UNIT (CRANE OR BODY)

Registration form must be mailed or faxed within 15 days of customer installation.

Mail to:
 Warranty Department
 Auto Crane Company
 P.O. Box 581510
 Tulsa, OK 74158-0697

5005EH-24V CONTROL OWNER'S MANUAL REVISION RECORD

Revision Date	Section(s) Or Page(s)	Description of Change
2/15/12	3.11	Add Rotation Bearing Instructions

Notes:

1. The information contained in this manual is in effect at the time of this printing. It does not cover all instructions, configurations, accessories, etc. If you require additional information, please contact **Auto Crane Company** at **(918) 836-0463**.
2. **Auto Crane Company** reserves the right to update this material without notice or obligation.

WARNINGS

WARNING! Federal law (49 cfr part 571) requires that the Final Stage Manufacturer of a vehicle certify that the vehicle complies with all applicable federal regulations. Any modifications performed on the vehicle prior to the final state are also considered intermediate stage manufacturing and must be certified as to compliance. The installer of this crane and body is considered one of the manufacturers of the vehicle. As such a manufacturer, the installer is responsible for compliance with all applicable federal and state regulations, and is required to certify that the vehicle is in compliance.

WARNING! It is the further responsibility of the installer to comply with the OSHA Truck Crane Stability Requirements as specified by 29 CFR part 1910.180 (C) (1).

WARNING! NEVER OPERATE THE CRANE NEAR ELECTRICAL POWER LINES!

Death or serious injury will result from boom, line, or load contacting electric lines. Do not use crane within 10 feet (3.05m) of electric power lines carrying up to 50,000 volts. One-foot additional clearance is required for every additional 30,000 volts or less. **SEE DANGER DECAL (P/N 040529)** in this Owner's Manual.

WARNING! NEVER.....

- ◆ **EXCEED** load chart capacities (centerline of rotation to hoist hook).
- ◆ Un-reel last 5 wraps of cable from drum!
- ◆ Wrap cable around load!
- ◆ Attempt to lift or drag a load from the side! The boom can fail far below its rated capacity.
- ◆ Weld, modify, or use unauthorized components on any Auto Crane unit! This will void any warranty or liability. Also failure of the crane may result.
- ◆ Place a chain link on the tip of the hook and try to lift a load!
- ◆ Use a sling bar or anything larger than the hook throat that could prevent the hook latch from closing, thus negating the safety feature!
- ◆ Hold on any pendant Select Switch that will cause unsafe operating conditions!

WARNING! In using a hook with latch, **ALWAYS** make sure that the hook throat is closed before lifting a load! Proper attention and common sense applied to the use of the hoist hook and various slings will prevent possible damage to material being hoisted and may prevent injury to personnel.

WARNING! Failure to correctly plumb and wire crane can cause inadvertent operation and damage to crane and/or personnel!

WARNING! Auto Crane Company remote controlled cranes are not designed or intended for use for any applications involving the lifting or moving of personnel.

WARNING! ALWAYS operate the crane in compliance with the load capacity chart. **DO NOT USE** the overload shutdown device to determine maximum rated loads, if the crane is equipped with this type of device.

READ THIS PAGE

5005EH-24V CONTROL TABLE OF CONTENTS

INTRODUCTION	1-1.0
GENERAL SPECIFICATIONS	1-3.0
SAFETY TIPS AND PRECAUTIONS	2-1.0
OPERATING PRACTICES & WARNINGS	2-3.0
QUALIFICATIONS FOR OPERATORS	2-4.0
OPERATION OF UNIT / OUTRIGGERS	2-7.0
INSPECTION	3-1.0
TESTING	3-4.0
MAINTENANCE	3-5.0
BATTERIES	3-7.0
LUBRICATION AND MAINTENANCE SCHEDULE	3-9.0
SAFETY DECAL SECTION	4-1.0
GENERAL DIMENSIONS	5-1.0
MOUNTING AND INSTALLATION	5-2.0
GENERAL ASSEMBLY, HARDWIRED	6-1.0
PEDESTAL ASSEMBLY, HARDWIRED	6-5.0
BOOM ASSEMBLY	6-13.0
ROTATION GEARBOX	6-15.0
HOIST ASSEMBLY	6-17.0
TRAVELING BLOCK ASSEMBLY	6-20.0
ELECTRICAL SECTION, HARDWIRED	7-3.0
PENDANT CABLE ASSEMBLY	7-7.0
HYDRAULIC SECTION	8-1.0
LOAD CHART	11-1.0
WARRANTY	LAST PAGE

5005EH-24V CONTROL INTRODUCTION

Auto Crane products are designed to provide many years of safe, trouble-free, dependable service when properly used and maintained.

To assist you in obtaining the best service from your crane and to avoid untimely crane and/or vehicle failure, this manual provides the following operating and service instructions. It is specifically recommended that all operating and service personnel consider this manual as mandatory material for reading and study before operating or servicing Auto Crane products. It is highly recommended that crane owners, equipment managers, and supervisors also read this manual.

Auto Crane has incorporated several safety features in the 5005EH-24VDC crane for your protection.

For your convenience the overall dimensions of the 5005EH-24VDC crane are included on the General Dimension Drawing. Rotation and turning radius are also listed on that drawing.

Remember, the crane adds weight to the vehicle. Adding weight may change the driving and riding characteristics of the vehicle unless the appropriate overload spring(s) are installed on the truck. The payload of the vehicle is reduced by the weight of the crane. The operator should exercise care when loading the vehicle. Distributing the payload on the vehicle evenly will greatly improve the driving and riding characteristics of the vehicle.

Auto Crane Company issues a limited warranty certificate with each unit sold. See last page for warranty.

The 5005EH-24VDC cranes are attached to your truck electrical system through the Voltage Switching Unit provided. The 5005EH-24VDC is another highly efficient Auto Crane product. The use of a maintenance-free battery is not recommended on any Auto Crane product. The recommended alternator and battery that will give the longest life with the most useful duty cycle is a 75-amp alternator with

a 500 cold cranking amp battery. These specifications should be considered minimum.

It has always been Auto Crane Company policy to handle all warranty claims we receive as promptly as possible. If a warranty claim involves discrepant material or workmanship, Auto Crane will take immediate corrective action. It is understandable that Auto Crane Company cannot assume responsibility of liability when it is obvious that our products have been abused, misused, overloaded or otherwise damaged by inexperienced persons trying to operate the equipment without reading the manual.

Auto Crane will not assume responsibility or liability for any modifications or changes made to unit, or installation of component parts without authorization.

Auto Crane maintains a strong distributor network and a knowledgeable Customer Service Department. In most cases, an equipment problem is solved via phone conversation with our customer service department. The customer service department also has the ability to bring a local distributor, a regional sales manager, or a factory serviceman into the solution of an equipment problem.

If, through no fault of Auto Crane Company, it is necessary to send an experienced factory serviceman on a field service call the rates stated in the Auto Crane Distributor's Flat Rate Manual will apply.

Auto Crane Company's extensive Research and Development Program allow our customers to use the best equipment on the market. Our Engineering Staff and our knowledgeable sales people are always available to our customers in solving crane and winch-type application problems. When in doubt, call the Auto Crane factory.

Note: This manual should remain with the crane at all times.

5005EH-24V CONTROL INTRODUCTION

DISTRIBUTOR ASSISTANCE:

Should you require any assistance not given in this manual, we recommend that you consult your nearest Auto Crane Distributor. Our distributors sell authorized parts and have service departments that can solve almost any needed repair. This manual does not cover all maintenance, operating, or repair instructions pertinent to all possible situations. **If you require additional information, please contact the Auto Crane Company at the following telephone number: (918) 836-0463.** The information contained in the manual is in effect at the time of this printing. Auto Crane Company reserves the right to update this material without notice or obligation.

5005EH-24V CONTROL GENERAL SPECIFICATIONS

DIMENSIONS

Width: 21.63 in (0.55 m)
Height: 35.75 in (0.91 m)
Length: 13 ft 1 in (3.99 m)
 [boom(s) stored]
Weight:
 1,455 lbs (758 kg)

CAPACITY

25,000 ft-lbs (3.46 ton-m)
 [ft-lbs = horizontal distance from centerline
 of rotation to free hanging weight (feet) x
 amount of weight (pounds)]

LIFTING CAPACITIES			
ft	lbs	ft	lbs
3	5,000	12	2,083
4	5,000	13	1,923
5	5,000	14	1,786
6	5,000	15	1,667
7	3,571	16	1,562
8	3,125	17	1,471
9	2,777	18	1,389
10	2,500	19	1,316
11	2,273	20	1,250

REACH

Second boom will reach from 10 feet 4 inches to 16 feet 4 inches.
 Third boom will reach from 16 feet 4 inches to 20 feet 4 inches.

CABLE

80 ft (24.38 m) of 5/16 in (7.9 mm) diameter aircraft quality cable. This cable has a single line breaking strength of 9,800 lbs (4,444 kg).

CHASSIS REQUIREMENTS

14,500 lbs (6,577 kg) GVWR minimum
 360,000 in-lbs RBM

ELECTRICAL SYSTEM REQUIREMENTS

Voltage: 24 VDC
Alternator: 75 amp (minimum)
Battery: 130 minute reserve capacity (minimum)
 Maintenance type

ROTATION

370° Rotation With Electrical Stop
 Continuous Rotation With Slip Ring

--- IMPORTANT ---

SAFETY TIPS AND PRECAUTIONS

1. No unqualified or unauthorized person shall be allowed to operate the crane.
2. **WARNING:** Never weld, modify, or use unauthorized components / parts on any Auto Crane unit. This will void any warranty or liability. Also, failure of the crane may result.
3. Make certain the vehicle meets minimum chassis requirements. (These requirements do not guarantee unit stability.)
4. Make certain the crane is installed per factory specifications. Contact your local distributor or the Auto Crane factory if any questions arise.
5. Visual inspections and tests should be conducted at the beginning of each shift each day to insure that the crane and all its operating systems are in good condition and working order before it is used.
6. Inspect hydraulic hoses frequently for signs of deterioration, and replace them as required.
7. If a hydraulic break occurs, leave the area of the break and do not attempt to stop the break by hand as the hydraulic oil may be hot and under high pressure which can cause serious injury. Shut the system down as soon as possible.
8. Check the hook at least every thirty days for distortions or cracks and replace it as required.
9. Oil gears as required.
10. Stop all operations when cleaning, adjusting or lubricating the machine.
11. Keep dirt and grit out of moving parts by keeping crane clean. Make sure machine is free of excess oil, grease, mud and rubbish, thus reducing accidents and fire hazards.
12. When a new cable is installed, operate first with a light load to let the cable adjust itself.
13. Locate the vehicle at the work site for the best stability possible.
14. Keep the vehicle in a level position while loading or unloading.
15. Observe operating area for obstructions and/or power lines that might be a hazard.
16. **WARNING: NEVER OPERATE THE CRANE NEAR ELECTRICAL POWER LINES.** Auto Crane Company recommends that the crane never be any closer to a power line (including telephone lines) than 10 feet at any point.
17. Allow the vehicle engine to warm up before operating crane.
18. Know the weight of your rigging and load to avoid overloading the crane.
19. Deduct the weight of the load handling equipment from the load rating to determine how much weight can be lifted.
20. All load ratings are based on crane capacity, NOT the vehicle stability. Remember in lifting a heavy load, the weight can create enough tipping moment to overturn the vehicle
21. Always comply with load chart capacities, (centerline of rotation to hook).
22. Secure all loads before lifting.
23. Always set the emergency brake before beginning operation.
24. Keep objects and personnel clear of crane path during operation.
25. Operate control levers slowly and smoothly in order to meter oil flow for safe operation.
26. Always extend the outriggers from vehicle to the ground before crane operation. Insure that they are firmly positioned on solid footings. Stand clear of outriggers while they are being extended.
27. If any outrigger, when extended, rests on a curb or other object that prevents it from extending to its maximum distance, shorten bearing or fulcrum point and reduce the maximum load accordingly.
28. When an outrigger will not reach the ground due to holes or grades, it shall be blocked up to provide level and firm support for the truck.
29. When working in soft earth, use wide pads under outrigger feet to prevent sinking.
30. Always store outriggers before transportation.

WARNING!

Auto Crane Company cranes are not designed or intended for use in lifting or moving persons. Any such use shall be considered to be improper and the seller shall not be responsible for any claims arising there from. This sale is made with the express understanding that there is no warranty that the goods shall be fit for the purpose of lifting or moving persons or other improper use and there is no implied warranty or responsibility for such purposes.

--- IMPORTANT ---

SAFETY TIPS AND PRECAUTIONS

31. Always store the crane in its stowed position for transportation.
32. Remember the overall height of the entire unit for garage door clearance or when moving under objects with low overhead clearance
33. Disengage power takeoff (PTO) before moving the vehicle.
34. Always walk around the vehicle before moving.
35. Never drive with a load suspended from crane.
36. Do not take your eyes off a moving load. Look in the direction you are moving.
37. Never swing a load over people.
38. Do not stop the load sharply in midair so that it swings like a pendulum. Meter the control levers to avoid this situation.
39. Crane boom length should be kept as short as possible for maximum lifting capacity and greater safety. Longer booms require additional care in accelerating and decelerating the swing motion, and thus slow down the working cycle and reduce productivity.
40. Keep the load directly and vertically under the boom point at all times. Crane booms are designed to handle vertical loads, not side lifts.
WARNING: Never attempt to lift, drag, tow or pull a load from the side. The boom can fail far below its rated capacity.
41. Do not push down on anything with boom extensions; similarly do not lift anything with boom extensions.
42. Do not lift personnel with any wire rope attachment or hook. There is no implied warranty or responsibility for such purposes.
43. **WARNING:** In using a safety hook, ALWAYS close the hook throat before lifting a load. Proper attention and common sense applied to the use of the hook and various slings will prevent possible damage to material being hoisted and may prevent injury to personnel.
44. **WARNING:** Never place a chain link on the tip of the hook and try to lift a load with the hoist.
45. **WARNING:** Never use a sling bar or anything larger than the hook throat which could prevent the safety latch from closing, thus negating the safety feature.
46. Do not wrap the wire rope around sharp objects when using winch.
47. **WARNING:** Never unreel last 5 wraps of cable from drum.

--- IMPORTANT --- OPERATING PRACTICES AND WARNINGS

1. Make certain the vehicle meets minimum chassis requirements. (These requirements do not guarantee unit stability)
2. Make certain the crane is installed per factory specifications. Contact your local Distributor or the Auto Crane factory if any questions arise.
3. Keep the vehicle in as level a position as possible while loading or unloading.
4. **ALWAYS** set the vehicle emergency brake before beginning crane operations.
5. **ALWAYS** use outriggers from vehicle to the ground during crane operation. Make sure they are firmly positioned on solid footings.
6. All load ratings are based on crane capacity, **NOT** truck/crane stability.
7. Keep objects and personnel clear of crane path during operation.
8. Keep hoist cable pulled tight at all times.
9. **REMEMBER**, in lifting a heavy load, the weight can create enough tipping momentum to overturn the vehicle.
10. **ALWAYS** keep load as close to ground as possible.
11. Hydraulic hoses need to be inspected frequently for signs of deterioration, and be replaced as required.
12. The hoist hook is an important item that an operator should consider and use properly. It should be checked on a daily basis for distortion or cracks.
13. **ALWAYS** store outriggers before road travel.
14. **WARNING! NEVER OPERATE THE CRANE NEAR ELECTRICAL POWER LINES!** Death or serious injury will result from boom, line, or load contacting electric lines. Do not use crane within 10 feet (3.05m) of electric power lines carrying up to 50,000 volts. One foot additional clearance is required for every additional 30,000 volts or less.
15. **WARNING! NEVER EXCEED** load chart capacities (centerline of rotation to hoist hook).
16. **WARNING! NEVER** un-reel last 5 wraps of cable from drum!
17. **WARNING! NEVER** wrap cable around load!
18. **WARNING! NEVER** attempt to lift or drag a load from the side! The boom can fail far below its rated capacity.
19. **WARNING! NEVER** weld, modify, or use unauthorized components on any Auto Crane unit! This will void any warranty or liability. Also failure of the crane may result.
20. **WARNING! NEVER** place a chain link on the tip of the hook and try to lift a load!
21. **WARNING! NEVER** use a sling bar or anything larger than the hook throat that could prevent the hook latch from closing, thus negating the safety feature!
22. **WARNING!** In using a hook with latch, **ALWAYS** insure that the hook throat is closed before lifting a load! Proper attention and common sense applied to the use of the hoist hook and various slings will prevent possible damage to material being hoisted and may prevent injury to personnel.
WARNING! NEVER hold any Control Select Switch on that will cause unsafe operating conditions!

WARNING!

Auto Crane Company remote controlled, stiff boom cranes are not designed or intended to be used for any applications involving the lifting or moving of personnel.

QUALIFICATIONS FOR AND CONDUCT OF OPERATORS AND OPERATING PRACTICES

REFERENCE ASME B30.5a AND OSHA 1910.180 FOR COMPLETE QUALIFICATION REQUIREMENTS

OPERATORS

1. Crane operation shall be limited to personnel with the following minimum qualifications:
 - A. Designated persons.
 - B. Trainees under the direct supervision of a designated person.
 - C. Maintenance and test personnel (when it is necessary in the performance of their duties).
 - D. Inspectors (crane).
2. No one other than the personnel specified above shall enter the operating area of a crane with the exception of persons such as oilers, supervisors, and those specified persons authorized by supervisors whose duties require them to do so and then only in the performance of their duties and with the knowledge of the operator or other persons.

QUALIFICATIONS FOR OPERATORS

1. Operators shall be required by the employer to pass a practical operating examination. Qualifications shall be limited to the specific type of equipment for which examined.
2. Operators and operator trainees shall meet the following physical qualifications:
 - A. Vision of at least 20/30 Snellen in one eye and 20/50 in the other, with or without corrective lenses.
 - B. Ability to distinguish colors, regardless of position, if color differentiation is required for operation.
 - C. Adequate hearing with or without hearing aid for the specific operation.
3. Evidence of physical defects or emotional instability, which render a hazard to operator or others, which in the opinion of the examiner could interfere with the operator's performance, may be sufficient cause for disqualification. In such cases, specialized clinical or medical judgment and tests may be required.
4. Evidence that operator is subject to seizures or loss of physical control shall be sufficient reason for disqualification. Specialized medical

tests may be required to determine these conditions.

5. Operators and operator trainees should have normal depth perception, coordination, and no tendencies to dizziness or similar undesirable characteristics.
6. In addition to the above listed requirements, the operator shall:
 - A. Demonstrate the ability to comprehend and interpret all labels, operator's manuals, safety codes, and other information pertinent to correct crane operations.
 - B. Posses the knowledge of emergency procedures and implement it.
 - C. Demonstrate to the employer the ability to operate the specific type of equipment.
 - D. Be familiar with the applicable safety regulations.
 - E. Understand the operating procedures as outlined by the manufacturer.
 - F. Be thoroughly familiar with the crane and its control functions.
 - G. Understand the operating procedures as outlined by the manufacturer.

CONDUCT OF OPERATORS

1. The operator shall not engage in any practice, which will divert his attention while actually operating the crane.
2. Each operator shall be responsible for those operations under the operator's direct control. Whenever there is any doubt as to safety, the operator shall consult with the supervisor before handling the loads.
3. The operator should not leave a suspended load unattended unless specific precautions have been instituted and are in place.
4. If there is a warning sign on the switch or engine starting controls, the operator shall not close the switch or start the engine until the warning sign has been removed by the appointed person.
5. Before closing the switch or starting the engine, the operator shall see that all controls are in the "OFF"

QUALIFICATIONS FOR AND CONDUCT OF OPERATORS AND OPERATING PRACTICES

- or neutral position and all personnel are in the clear.
6. If power fails during operation, the operator shall:
 - A. Move power controls to the "OFF" or neutral position.
 - B. Land the suspended load and boom, if practical.
 7. The operator shall be familiar with the equipment and its proper care. If adjustments or repairs are necessary, the operator shall report the same promptly to the appointed person, and shall also notify the next operator.
 8. The operator at the start of each shift shall test all controls. If any controls do not operate properly, they shall be adjusted or repaired before operations are begun.
 9. Stabilizers shall be visible to the operator while extending or setting unless a signal person assists operator.
- C. Means are provided to hold the vehicle stationary while operating the crane.
 - D. Before starting to lift, the hook shall be positioned over the load in such a manner as to minimize swinging.
 - E. During lifting care shall be taken that:
 1. There is no sudden acceleration or deceleration of the moving load.
 2. Load, boom or other parts of the crane do not contact any obstruction.
 - F. Cranes shall not be used for dragging loads sideways.
 - G. This standard recognizes that telescopic boom cranes are designed and intended for handling materials. They do not meet personnel lift or elevator requirements. Therefore, no lifting, lowering, swinging or traveling shall be done while a person is on the hook or load. Hook attached suspended work platforms (baskets) shall not be used with cranes covered by this standard. Crane manufacturer must approve work platforms attached to the boom.
 - H. The operator should avoid carrying loads over people.
 - I. When the crane is so equipped, the stabilizers shall be fully extended and set. Blocking under stabilizers shall meet the requirements as follows:
 1. Strong enough to prevent crushing.
 2. Of such thickness, width and length as to completely support the stabilizer pad.
 - J. Firm footing under all tires, or individual stabilizer pads should be level. Where such a footing is not otherwise supplied, timbers, cribbing, or other structural members to distribute the load so as to not exceed allowable bearing capacity or the underlying material should provide it.
 - K. In transit, the boom shall be carried in stowed position.
 - L. When rotating the crane, sudden starts and stops shall be avoided. Rotational speed shall be such that the load does not swing out beyond the radius at which it can be controlled.
 - M. The crane shall not be transported with a load on the hook unless recommended by the manufacturer.

OPERATING PRACTICES/HANDLING THE LOAD

1. Size of load.
 - A. No crane shall be loaded beyond the rated load except for test purposes.
 - B. The load to be lifted is to be within the rated load of the crane and its existing configuration.
 - C. When loads that are not accurately known are to be lifted, the person responsible for the job shall ascertain that the weight of the load does not exceed the crane rated load at the radius at which the load is to be lifted.
2. Attaching the load.
 - A. The load shall be attached to the hook by means of slings or other devices of sufficient capacity.
 - B. Hoist rope shall not be wrapped around the load.
3. Moving the load.

The operator shall determine that:

 - A. The crane is level and, where necessary, the vehicle/carrier is blocked properly.
 - B. The load is well secured and balanced in the sling or lifting device before it is lifted more than a few inches.

QUALIFICATIONS FOR AND CONDUCT OF OPERATORS AND OPERATING PRACTICES

N. No person should be permitted to stand or pass under a suspended load.

4. Stowing procedure.

Follow the manufacturer's procedure and sequence when stowing and un-stowing the crane.

3. Caution shall be exercised when working near overhead lines, because they can move horizontally or vertically due to wind, moving the danger zone to new positions.

4. In transit with no load and boom lowered the clearance shall be specified in Table 1.

5. A qualified signalperson shall be assigned to observe the clearance and give warning before approaching the above limits.

MISCELLANEOUS

OPERATING NEAR ELECTRICAL POWER LINES

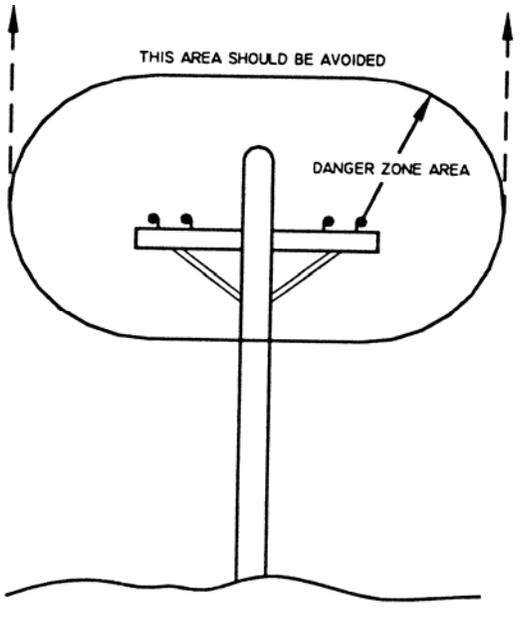

1. Cranes shall be operated so that no part of the crane or load enters into the danger zone shown above.

EXCEPTIONS

A. The danger zone may be entered after confirmation by an appointed person that the electrical distribution and transmission lines have been de-energized and visibly grounded at the point of work; or

B. The danger zone may be entered if insulating barriers (not a part of nor an attachment to the crane) have been erected to prevent physical contact with the lines.

2. For lines rated 50 kV or below, minimum clearance between the lines and any part of the crane or load (including handling appendages) shall be 10-ft. (3m). For higher voltages, see Table 1.

A. Any overhead wire shall be considered to be an energized line unless and until the person owning such line or the electrical utility authorities verify that it is not an energized line.

B. Exceptions to this procedure are allowed, if approved by the administrative or regulatory authority provided the alternate procedure insures equivalent protection and is set forth in writing.

C. Durable signs shall be installed at the operator's station and on the outside of the crane, warning that electrocution or serious bodily injury may occur unless a minimum clearance of 10 ft. (3.0m) between the crane or the load being handled and energized power lines. Greater clearances are required because of higher voltage as stated above. These signs shall be revised but not removed when local jurisdiction requires greater clearances.

TABLE 1

normal voltage, kV (phase to phase)		minimum required clearance	
		ft	(m)
<u>when operating near high voltage power lines</u>			
over	to 50	10	(3.50)
over	50 to 200	15	(4.6)
over	200 to 350	20	(6.1)
over	350 to 500	25	(7.62)
over	500 to 750	35	(10.67)
over	750 to 1000	45	(13.72)
<u>while in transit with no load and boom lowered</u>			
over	to 0.75	4	(1.22)
over	0.75 to 50	6	(1.83)
over	50 to 345	10	(3.83)
over	345 to 750	16	(4.87)
over	750 to 1000	20	(6.1)

--- IMPORTANT --- OPERATION OF UNIT

1. Make sure this manual has been thoroughly read by all crane operating personnel and supervisors.
2. A routine inspection of the crane should be mandatory before each operating day. Any defects should be corrected immediately.
3. At a job site the vehicle should be positioned so that the crane can adequately reach the load within the rated capacity (centerline of rotation to hoist hook).
4. Keep the vehicle as level as possible during operation.
5. For electric cranes, **engage emergency brake** and leave ignition on with transmission in neutral (or in park for automatic transmissions). Activate any crane power switches. For Auto Crane units requiring battery and hydraulic operation, **engage emergency brake**, place gear selector in neutral, press clutch, activate PTO, release clutch and after hydraulic fluid is warm, set throttle control to proper engine speed.
6. Always use outriggers from the truck to the ground. Be sure these are firm and adequately positioned. When rotating, **keep load as low to the ground as possible**.
7. Remove the transmitter from cab or storage area. Power transmitter on. Detach hook from dead man. Crane is now ready for operation.
8. Always boom up before rotating so the boom will clear the required boom support.
9. When extending the boom, always maintain clearance between the boom crown and the traveling block or hoist hook.
10. Always observe safe and practical operation to avoid possible accidents. Refer to Safety Tips and Precautions.
11. After completing lifting operations, return the boom to stowed position on the boom support. Avoid unneeded pressure on the boom support.
12. Store transmitter in proper location (in cab or storage area).
13. Return outriggers to stowed position. Make sure they are pinned in place or jacklegs are returned to compartment.
14. Check work area for any tools or equipment not stored.
15. Release throttle control, depress clutch and disengage PTO. Deactivate any crane power switches.
16. Report any unusual occurrence during crane operation that may indicate required maintenance or repair.
17. **NEVER** use two cranes to support a load too large for either crane.

OPERATION OF OUTRIGGERS

HYDRAULIC OUTRIGGERS

1. Shift crane/outrigger control valve to "outrigger" position.
2. Operate the outrigger control valves to position the outriggers.
3. After outriggers are positioned, return crane/outrigger selector to "crane" position.
4. Crane is now ready to operate.

MANUAL OUTRIGGERS

1. Pull lock pins to release jackleg or drop down outrigger and move to outermost lock position.
2. Make sure lock pins are reinstalled properly.
3. Lower outrigger pad to firm ground and adjust foot to take out slack.
4. Crane is now ready to operate.

INSPECTION REQUIREMENTS

REFERENCE ASME B30.5a AND OSHA 1910.180 FOR COMPLETE INSPECTION REQUIREMENTS

INSPECTION CLASSIFICATION

1. Initial inspection.

Prior to initial use, all new, altered, modified or extensively repaired cranes shall be inspected by a designated person to insure compliance with provisions of this standard.

2. Regular inspection.

Inspection procedure for cranes in regular service is divided into two general classifications based upon the intervals at which inspection should be performed. The intervals in turn are dependent upon the nature of the components of the crane and the degree of their exposure to wear, deterioration, or malfunction. The two general classifications are herein designated as "frequent" and "periodic" with respective intervals between inspections as defined below.

- A. Frequent inspection - daily or before each use
- B. Periodic inspection - one to twelve-month intervals or as specifically recommended by the manufacturer or qualified person.

**DESIGNATED PERSONNEL SHALL
PERFORM INSPECTIONS ONLY.**

FREQUENT INSPECTION

Inspections should also occur during operation for any deficiencies that might appear between regular inspections. Any deficiencies, such as those listed below, shall be carefully examined and a determination made as to whether they constitute a hazard:

1. Inspect control mechanisms for maladjustment that interferes with proper operation.
2. Inspect control mechanisms for excessive wear of components and contamination by lubricants or other foreign matter.

3. Inspect safety devices for malfunction.
4. Visually inspect all hydraulic hoses, particularly those that flex in normal operation of crane functions.
5. Inspect hooks and latches for deformation, chemical damage, cracks, and wear. Refer to ANSI/ASME B30.10.
6. Inspect for proper rope reeving.
7. Inspect electrical wiring and components for malfunctioning, signs of excessive deterioration, dirt and moisture accumulation.
8. Inspect hydraulic system for proper oil level and leaks.
9. Inspect tires for recommended inflation pressure, cuts and loose wheel nuts.
10. Inspect connecting pins and locking device for wear damage and loose retaining bolts.
11. Inspect rope for gross damage, such as listed below, which may be an immediate hazard.
 - A. Distortion such as kinking, crushing, unstranding, birdcaging, main strand displacement, or core protrusion. Loss of rope diameter in a short length or unevenness of outer strands should be replaced.
 - B. General corrosion.
 - C. Broken or cut strands.
 - D. Use care when inspecting sections of rapid deterioration around flange points, crossover points, and repetitive pickup points on drums.
 - E. Inspect number, distribution, and type of visible broken wires. Reference Rope Maintenance section in the owner's manual.

Continued use of rope depends upon good judgment by a designated person in evaluating remaining strength in a used rope after allowance for deterioration disclosed by inspection. Continued rope operation depends upon this remaining strength.

INSPECTION REQUIREMENTS

PERIODIC INSPECTION

Any deficiencies, such as those listed below, shall be carefully examined and determination made as to whether they constitute a hazard:

1. Inspect for deformed, cracked or corroded members in the crane structure and entire boom.
2. Inspect for loose bolts, particularly mounting bolts.
3. Inspect for cracked or worn sheaves and drums.
4. Inspect for worn, cracked, or distorted parts such as pins, bearings, shafts, gears, rollers and devices.
5. Inspect for excessive wear on brake and clutch system parts and lining.
6. Inspect crane hooks for cracks.
7. Inspect travel steering, braking, and locking devices for malfunction.
8. Inspect for excessively worn or damaged tires.
9. Inspect hydraulic hose, fittings, and tubing for the following problems:
 - A. Evidence of leakage at the surface of the flexible hose or its junction with metal and coupling.
 - B. Blistering, or abnormal deformation to the outer covering of the hydraulic or pneumatic hose.
 - C. Leakage at threaded or clamped joints that cannot be eliminated by normal tightening or recommended procedures.
 - D. Evidence of excessive abrasion or scrubbing on the outer surface of a hose, rigid tube, or fitting. Means shall be taken to eliminate the interference of elements in contact or otherwise protect the components.
10. Inspect hydraulic pumps and motors for the following problems:
 - A. Loose bolts and fasteners.
 - B. Leaks at joints between sections.
 - C. Shaft seal leaks.
 - D. Unusual noises or vibrations.
 - E. Loss of operating speed.
 - F. Excessive heating of the fluid.
 - G. Loss of pressure.
11. Inspect hydraulic valves for the following problems:
 - A. Cracks in valve housing.
 - B. Improper return of spool to neutral position.
 - C. Leaks at spools or joints.
 - D. Sticking spools.
 - E. Failure of relief valves to attain or maintain correct pressure setting.
 - F. Relief valve pressure shall be checked as specified by the manufacturers.
12. Inspect hydraulic cylinders for the following problems:
 - A. Drifting caused by fluid leaking across piston.
 - B. Rod seals leaking.
 - C. Leaks at welding joints.
 - D. Scored, nicked, or dented cylinder rods.
 - E. Damaged case (barrel).
 - F. Loose or deformed rod eyes or connecting joints.
13. Inspect hydraulic filters for evidence of rubber particles on the filter elements indicating possible hose, "O" ring, or other rubber component deterioration. Metal chips or pieces on the filter may denote failure in pumps, motors, or cylinders. Further inspection will be necessary to determine the origin of the problem before corrective action can be taken.
14. Inspect labels to confirm correct location and legibility. Reference decal layout in this manual for proper location of decals.
15. **Rope Inspections need not be at equal calendar intervals and should be more frequent as the rope approaches the end of useful life.** A qualified person shall inspect the wire rope based on such factors as:
 - A. Expected rope life as determined by experience on the particular installation or similar installations.
 - B. Severity of environment.
 - C. Percentage of capacity lifts.
 - D. Frequency rates of operation.
 - E. Exposure to shock loads.This inspection shall cover the entire length of the rope. Only the surface wires need to be inspected and no attempt should be made to open the rope. Any deterioration resulting in appreciable loss of original strength shall be noted and determination made as to whether use of the rope would constitute a hazard. A few notable deterioration points are listed below:

INSPECTION REQUIREMENTS

- A. Reduction of rope diameter below nominal diameter due to loss of core support.
- B. Internal or external corrosion.
- C. Wear of outside wires.
- D. Severely corroded, cracked, bent, worn, or improperly applied connections.

CRANES NOT IN REGULAR USE

A crane, which has been idle for a period of over one month or more, shall be given an inspection conforming to the "initial" and "regular" inspection requirements of this section.

INSPECTION RECORDS

Dated records of periodic inspection should be made on critical items such as brakes, crane hooks, rope, cylinders, and relief pressure valves.

TESTING REQUIREMENTS

REFERENCE ASME B30.5a AND OSHA 1910.180 FOR COMPLETE TESTING REQUIREMENTS

TESTING SHALL BE PERFORMED BY DESIGNATED PERSONNEL ONLY.

Prior to initial use, all new, altered, modified, or extensively repaired cranes shall be tested for compliance with the operational requirements of this crane.

Test requirements:

1. Test all functions to verify speed and operation.
2. Check that all safety devices are working properly.
3. Confirm operating controls comply with appropriate function labels.
4. Test loads shall not exceed 110% of the manufacturer's load rating.
5. Written reports shall be maintained showing test procedures and confirming the adequacy of repairs.

GENERAL REPAIRS AND MAINTENANCE

REFERENCE ASME B30.5a AND OSHA 1910.180 FOR COMPLETE MAINTENANCE AND REPAIR REQUIREMENTS

A preventative maintenance program should be established based on this section and all replacement parts should be obtained from AutoCrane Company.

For replacement parts contact your local authorized distributor.

MAINTENANCE PRECAUTIONS

1. Place crane where it will cause the least interference with other equipment or operations.
2. Verify all controls are in the "off" position and all operating features secured from inadvertent motion by brakes, pawls, or other means.
3. The means for starting the crane shall be rendered inoperative.
4. The boom should be secured in place before maintenance.
5. Relieve hydraulic oil pressure from all hydraulic circuits before loosening or removing hydraulic components.
6. Warning or "OUT OF ORDER" signs shall be placed on all crane controls.
7. After adjustments and repairs have been made, the crane shall not be returned to service until all guards have been reinstalled, trapped air removed from hydraulic system (if required), safety devices reactivated, and maintenance equipment removed.

ADJUSTMENTS AND REPAIRS

1. Any hazardous conditions disclosed by the inspection requirements shall be corrected before operation of crane is resumed. Only designated personnel shall do adjustments and repairs.
2. Adjustments shall be maintained to assure correct functioning of components, the following are examples:
 - A. Functional operating mechanism.
 - B. Safety devices.
 - C. Control systems.
3. Repairs or replacements shall be provided as needed for operation, the following are examples:
 - A. Critical parts of functional operating mechanisms which are cracked, broken, corroded, bent, or excessively worn.

- B. Critical parts of the crane structure which are cracked, bent, broken, or excessively corroded.
 - C. Crane hooks showing cracks, damage, or corrosion shall be taken out of service. Repairs by welding are not recommended.
4. If bleeding the hydraulic system is required, run each crane function until smooth operation of that particular function is noticeable.

LUBRICATION

All moving parts of the crane, for which lubrication is specified, should be regularly lubricated per the manufacturer's recommendations and procedures. **Reference Lubrication and Maintenance Schedule in this manual.**

ROPE REPLACEMENT

No precise rules can be given for determination of the exact time for replacement of rope, since many variable factors are involved.

1. Conditions such as the following shall be reason for questioning continued use of the rope or increasing the frequency of inspection:
 - A. In running ropes, six randomly distributed broken wires in one lay or three broken wires in one strand in one lay.
 - B. One outer wire broken at the contact point with the core of the rope structure and protrudes or loops out of the rope structure. Additional inspection of this section is required.
 - C. Wear of one third of the original diameter of the outside individual wire.
 - D. Kinking, crushing, bird caging, or any other damage resulting in distortion of the rope structure.
 - E. Evidence of any heat damage from any cause.
 - F. Reduction from nominal diameter of more than 1/64 in. (0.4mm) for diameters up to and including 5/16 in. (8 mm), 1/32 in. (0.8 mm) for diameter 3/8 in. (9.5 mm) to and including 1/2 in. (13 mm), 3/64 in. (1.2 mm) for diameter 9/16 in. (14.5 mm) to and including 3/4 in. (19 mm), 1/16 in. (1.6 mm) for diameter 7/8 in. (22 mm) to and including 1 1/8 in. (29 mm), 3/32 in.

GENERAL REPAIRS AND MAINTENANCE

(2.4 mm) for diameters 1 1/4 in. (32 mm) to and including 1 1/2 in. (38 mm).

- G. In standing ropes, more than two broken wires in one lay in sections beyond end connections or more than one broken wire at an end connection.
- 2. Replacement rope shall have a strength rating at least as great as the original rope furnished or recommended by AutoCrane. A rope manufacturer, AutoCrane, or a qualified person shall specify any deviation from the original size, grade, or construction.

ROPE MAINTENANCE

- 1. Rope should be stored to prevent damage or deterioration.
- 2. Unreeling or uncoiling of rope shall be done as recommended by the rope manufacturer and with care to avoid kinking or inducing twist.
- 3. Before cutting a rope, seizing shall be placed on each side of the place where the rope is to be cut to prevent unlaying of the strands. On pre-formed rope, one seizing on each side of the cut is required. On non-preformed ropes of 7/8 in. (22 mm) diameter or smaller, two seizings on each side of the cut are required, and for non-preformed rope 1 in. (25 mm) diameter or larger, three seizings on each side of the cut are required.
- 4. During installation care should be exercised to avoid dragging of the rope in the dirt or around objects that will scrape, nick crush or induce sharp bends in it.
- 5. Rope should be maintained in a well-lubricated condition. It is important that lubricant applied as a part of a maintenance program shall be compatible with the original lubricant and to this end the rope manufacturer should be consulted. Lubricant applied shall be the type that does not hinder visual inspection. Those sections of rope that are located over sheaves or otherwise hidden during inspection and maintenance procedures require special attention when lubricating rope. The object of rope lubrication is to reduce internal friction and to prevent corrosion.
- 6. When an operating rope shows greater wear or well-defined localized areas than on the remainder of the rope, rope life can be extended in some cases by shifting the wear to different areas of the rope.

MAINTENANCE OF BATTERIES

Maintenance of Auto Crane unit batteries differs very little from the generally prescribed maintenance of any lead acid battery. All batteries must be kept properly charged, properly filled with water, and relatively clean.

Keep Properly Charged

Many things affect the proper charge to a battery, such as:

1. Regulator settings.
2. Proper tightness of belts on the alternator or generator.
3. Good, clean connections of all cables and wires at the following places:
 - a. Battery.
 - b. Regulator.
 - c. Starting motor.
 - d. Alternator or generator.
 - e. Ground connections (most important).

It is of extreme importance to keep the battery as fully charged as possible without overcharging, especially when vehicles are left outside for extended periods in extremely cold climates. A battery can freeze. Freezing points for various specific gravities of acid are as follows:

Specific Gravity (Corrected to 80°F)	Freezing Temp. Degrees F.
1.280	-90°F
1.250	-62°F
1.200	-16°F
1.150	5°F
1.100	19°F

As shown, a half-charged battery (about 1.100 specific gravity) cannot stand for any length of time at 20°F or it will freeze.

The main reason for keeping the battery as fully charged as possible without over-charging is to insure that power is available even though the vehicle has been standing for some time.

Keep Properly Filled with Water

The battery should *always* be properly filled with water. If the electrolyte level is allowed to fall below the top of the plates, the results become threefold:

1. The exposed portion of the plate will become sulfated.
2. The portion of the plate exposed is not usable.
3. That portion of the acid remaining becomes more concentrated and may cause more rapid

deterioration of the remaining parts of the battery.

Keep A Relatively Clean Battery

The battery should be kept clean. Batteries filled with acid and which are not in use self-discharge to a limited degree because of the nature of the materials within the battery. If dirt is allowed to collect on the top of the battery (and this dirt absorbs moisture) and electrical path can be set up between the various terminals of the battery and the ground. Once such a path has been established, the self-discharge of the battery is accelerated. This also accelerates corrosion of the battery cables at the terminals.

Periodic Maintenance is Needed

A definite program of periodic maintenance of all batteries should be conducted on a regular basis. Periodic maintenance includes:

1. Checking belts for tightness on the charging equipment.
2. Checking battery electrolyte levels.
3. Checking cables for good connections.
4. Cleaning where corrosion is apparent.

When corrosion is cleaned off, the cable terminals and battery terminals should be coated with a light coating of petroleum jelly before they are replaced. When terminals are cleaned, the top of the battery should be cleaned with a mild solution of soda water.

Low Maintenance Batteries (Maintenance Free)

Low maintenance batteries should not be used on AutoCrane Cranes or trucks equipped with AutoCrane Cranes. The batteries are not designed for "deep" discharge.

Testing Your Battery

If the condition of the battery is in question, it should be removed from the vehicle, taken to the shop, and allowed to reach room temperature. It should then be recharged until specific gravity readings taken at one-half hour intervals. If the specific gravity readings are fairly uniform, the battery should be checked with a high rate tester. Use the tester in accordance with the manufacturer's instructions. The high rate tester is the best method to test a questionable battery.

MAINTENANCE OF BATTERIES

If, after charging, it is noted that the specific gravity reading of one cell is 30 points less than any of the other cells, it may be assumed that the cell is bad and that the battery should be replaced. If all cells are uniform but not up to full charge, a low rate of charge should be attempted for an extended time. This usually will recover a badly sulfated battery.

Replacing a Battery

If it is necessary to replace a battery, and a dry charge battery is used, the following procedure applies:

1. Fill the battery with electrolyte of the proper specific gravity.

2. Place the battery on charge according to the manufacturer's instructions.

It is essential that the second step above be followed to ensure that the battery going on the vehicle is fully charged.

It is also very important that the battery hold-downs be checked periodically to insure that the batteries are properly positioned to avoid vibration problems, breakage of cables or terminals. Care must be taken to avoid cracking or breaking containers or covers by tightening hold-down fixtures excessively. They also must not be so loose that breakage results from a hold-down that is too loose.

5005EH-24V CONTROL LUBRICATION & MAINTENANCE SCHEDULE

SERVICE PERFORMED	DAY	WKLY	3 MOS	6 MOS	YEAR	NOTES
LOAD HOOK	X					INSPECT HOOK & LATCH FOR DEFORMATION, CRACKS, & CORROSION
CABLE DRUM	X					MAKE SURE CABLE IS WOUND EVENLY ON DRUM
HOIST / BOOM CABLE	X					CHECK FOR FLATTENING, KINKS, & BROKEN STRANDS, SEE MANUAL
HYD. HOSES	X					VISUAL INSPECTION
HYD. FLUID	X					CHECK FLUID LEVEL
PIN RETAINING BOLTS	X					CHECK TORQUE TO 23 FT-LBS (GRADE 5), 35 FT-LBS (GRADE 8) AS REQUIRED
MOUNTING BOLTS		X				CHECK TORQUE TO 501 FT-LBS AS REQUIRED
ROTATION RING GEAR		X				LUBE WITH MOBILETAC LL, OR LUBRIPLATE P/N 15263, OR EQUAL
SHEAVE BEARINGS		X				SEALED BEARING, REPLACE IF ROUGH OR LOOSE
ALL OTHER BOLTS		X				CHECK TIGHTEN AS REQUIRED
LIFT CYLINDER BEARINGS			X			GREASE WITH MOBILEPLEX EP-2 OR EQUIVALENT @ ZERKS
ROTATION BEARING			X			GREASE WITH MOBILEPLEX EP-2 OR EQUIVALENT @ ZERKS
ROTATION BEARING BOLTS			X			CHECK TORQUE TO 170 FT-LBS (HEX HEAD) 180 FT-LBS (SOCKET HEAD) AS REQUIRED
ROTATION GEAR BOX			X			CHECK TORQUE TO 90 FT-LBS (SOCKET HEAD) AND 55 FT-LBS (HEX HEAD) AS REQUIRED
ROTATION GEAR BOX				X		EP GEAR LUBE SAE 80-90
HYDRAULIC FLUID					X	DRAIN, FLUSH, AND REFILL WITH MOBILE DTE 13 HYD. OIL
BOOM SLIDE PADS	PADS GREASED WHEN REPLACED					
FOR ADDITIONAL INFORMATION SEE:	1) OWNER'S MANUAL 2) OSHA SECTION 1910.180 3) ANSI B30.5-1989					

CAUTION: Routine maintenance insures trouble-free operation and protects your investment. All warranties are void if maintenance is neglected.

5005EH-24V CONTROL LUBRICATION & MAINTENANCE SCHEDULE

NOTES:

1. Use only authorized parts. Any damage or malfunction caused by the use of unauthorized parts is not covered by Warranty or Product Liability.
2. Once a bolt has been torqued to its rated capacity and then removed; the bolt should be replaced with a new one.
3. Auto Crane Company recommends that this crane be serviced per "Crane Inspection Log" P/N 999978. These logs should be filled in at the intervals noted and kept as a permanent record. Additional copies are available from your local distributor.

ROTATION BEARING REPLACEMENT GUIDELINES—5005 THRU 8406

All bearings can wear over time. This includes the main rotation bearing on the crane. No precise rules can be given for replacement of the rotation bearing, since many factors are involved. However, there are common symptoms seen during crane operation that may be caused by rotation bearing wear. These symptoms include:

1. Excessive Noise
2. Rough rotation
3. Increased drive power required to rotate.
4. Metal particles in grease

REASONS FOR ROTATION BEARING REPLACEMENT

1. Any noticeable cracking in the bearing housing
2. Damage to internal teeth
3. Excessive axial play (reference axial play check instructions below)

WARNING—NEVER TRY TO REPAIR A ROTATION BEARING. FOR A REPLACEMENT BEARING CONTACT YOUR LOCAL AUTHORIZED DISTRIBUTOR.

AXIAL PLAY ALLOWANCE CHECK PROCEDURE

1. Boom up to the max boom angle and measure the clearance between base plate and the rotation bearing with a dial or filler gauge. Reference figure 1 for location.
2. Boom down to the horizontal position and measure the clearance between the base plate and the rotation bearing with a dial indicator or feeler gauge. Reference figure 1 for location.
3. If the difference between the two measurements exceeds 1/16 inch, replace bearing.
4. Rotate crane 45 degrees then repeat steps above until you reach 360 degrees of rotation.

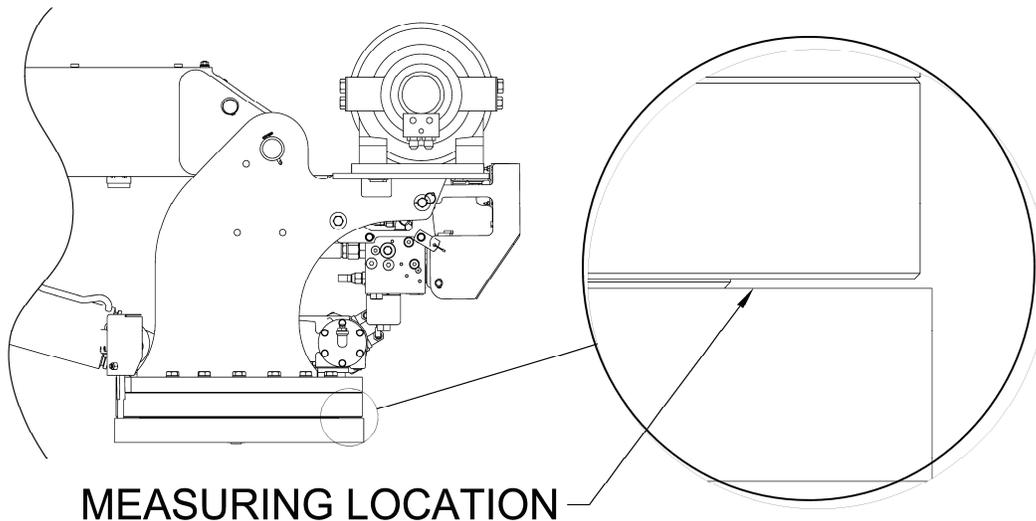

Rotation bearing replacement kit part number is 480023010

WARNING—WHEN REPLACING ROTATION BEARING, USE NEW HARDWARE WHICH IS INCLUDED IN THE KIT ABOVE.

5005EH-24V CONTROL SAFETY DECAL SECTION

PART NO.: 040579000
 DECAL: OPERATING INSTRUCTIONS
 FUNCTION: To inform the operator of the proper procedure to follow for safe operation of the crane.
 USED ON: All Cranes
 QUANTITY: 1
 PLACEMENT: Right side plate

⚠ CAUTION

1. INSPECT VEHICLE AND CRANE INCLUDING OPERATION, PRIOR TO USE DAILY.
2. DO NOT USE THIS EQUIPMENT EXCEPT ON SOLID, LEVEL SURFACE WITH OUTRIGGERS PROPERLY EXTENDED AND CRANE MOUNTED ON FACTORY-RECOMMENDED TRUCK.
3. BEFORE OPERATING THE CRANE, REFER TO MAXIMUM LOAD (CAPACITY) CHART ON CRANE FOR OPERATING (LOAD) LIMITATIONS.
4. OPERATE ALL CONTROLS SLOWLY AND SMOOTHLY.
5. KEEP LOAD UNDER BOOM TIP. DO NOT SIDE LOAD BOOM OR DRAG LOADS. AVOID FREE SWINGING LOADS.
6. DO NOT OPERATE, WALK OR STAND BENEATH BOOM OR A SUSPENDED LOAD.
7. KEEP AT LEAST 5 WRAPS OF LOADLINE ON HOIST DRUM.
8. FOR TRAVELING, BOOM AND OUTRIGGERS MUST BE IN THE STOWED POSITION.
9. ALL REMOVABLE PENDANTS MUST BE STORED IN CAB OR TOOL COMPARTMENT WHEN CRANE IS NOT IN USE.

P/N 040579

PART NO.: 040580000
 DECAL: OPERATING TRAINING
 FUNCTION: To inform the operator of the need to receive proper training before using the crane.
 USED ON: All Cranes
 QUANTITY: 1
 PLACEMENT: Right side plate

⚠ DANGER

AN UNTRAINED OPERATOR
SUBJECTS HIMSELF AND
OTHERS TO

DEATH OR SERIOUS INJURY

- 1.) YOU MUST HAVE BEEN TRAINED IN THE OPERATION OF THIS CRANE, AND
- 2.) YOU MUST KNOW AND FOLLOW THE SAFETY AND OPERATING RECOMMENDATIONS CONTAINED IN THE MANUFACTURER'S MANUAL, YOUR EMPLOYER'S WORK RULES AND APPLICABLE GOVERNMENT REGULATIONS.

P/N 040580

PART NO.: 040632000
 DECAL: TAMPERING WITH OVERLOAD DEVICE
 FUNCTION: To inform the operator that tampering with the overload device may cause a unit failure or possible personal injury.
 USED ON: All Cranes equipped with a load sensor
 QUANTITY: 1
 PLACEMENT: Right side of valve sensor.

⚠ WARNING

TAMPERING WITH OVERLOAD DEVICE VOIDS WARRANTY. OVERLOADED CRANE MAY HYDRAULICALLY RELEASE AND LET LOAD DOWN TO GROUND. OVERLOAD PROTECTION DEVICE CANNOT FUNCTION WITH BOOM BELOW HORIZONTAL (0°). HOIST UP, BOOM DOWN, AND EXTEND OUT WILL BE INOPERATIVE WHEN CRANE IS IN OVERLOAD CONDITION.

P/N 040632

5005EH-24V CONTROL SAFETY DECAL SECTION

PART NO.: 040529000
 DECAL: ELECTROCUTION HAZARD
 FUNCTION: To inform the operator of the hazard involved with contacting electrical power lines with crane boom.
 USED ON: All Cranes
 QUANTITY: 2
 PLACEMENT: Both sides of end of lower boom

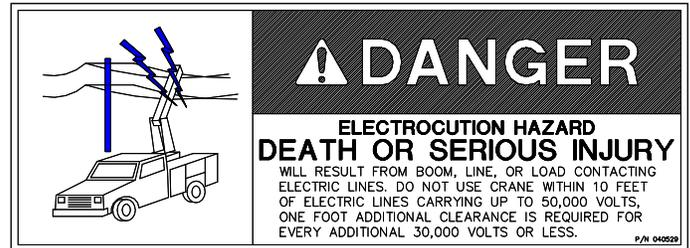

PART NO.: 040517000
 DECAL: STAY CLEAR OF BOOM
 FUNCTION: To inform the operator of the hazard of proximity or contact with the crane boom during operation.
 USED ON: All Cranes
 QUANTITY: 2
 PLACEMENT: Both sides of crown

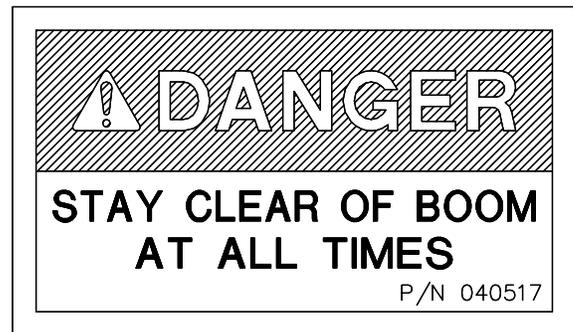

PART NO.: 040518000
 DECAL: STAY CLEAR OF LOAD
 FUNCTION: To inform the operator of the hazard of proximity or contact with the crane load during operation.
 USED ON: All Cranes
 QUANTITY: 2
 PLACEMENT: Both sides of traveling block



5005EH-24V CONTROL SAFETY DECAL SECTION

PART NO.: 040587000

DECAL: LOAD SENSOR, DON'T TAMPER

FUNCTION: To inform the operator that the load sensor is pre-set and that tampering with the sensor may cause potentially hazardous situation.

USED ON: All cranes equipped with a load sensor.

QUANTITY: 2

PLACEMENT: Both sides of the lift cylinder near the load sensor



PART NO.: 040519000

DECAL: SCISSORS POINT

FUNCTION: To inform the operator of possible danger at scissors point on crane.

USED ON: All cranes.

QUANTITY: 2

PLACEMENT: Both sides of the lift cylinder

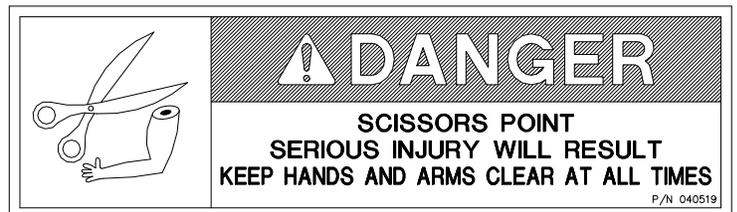

NOTES

5005EH DECAL LAYOUT

P/N: 360682000

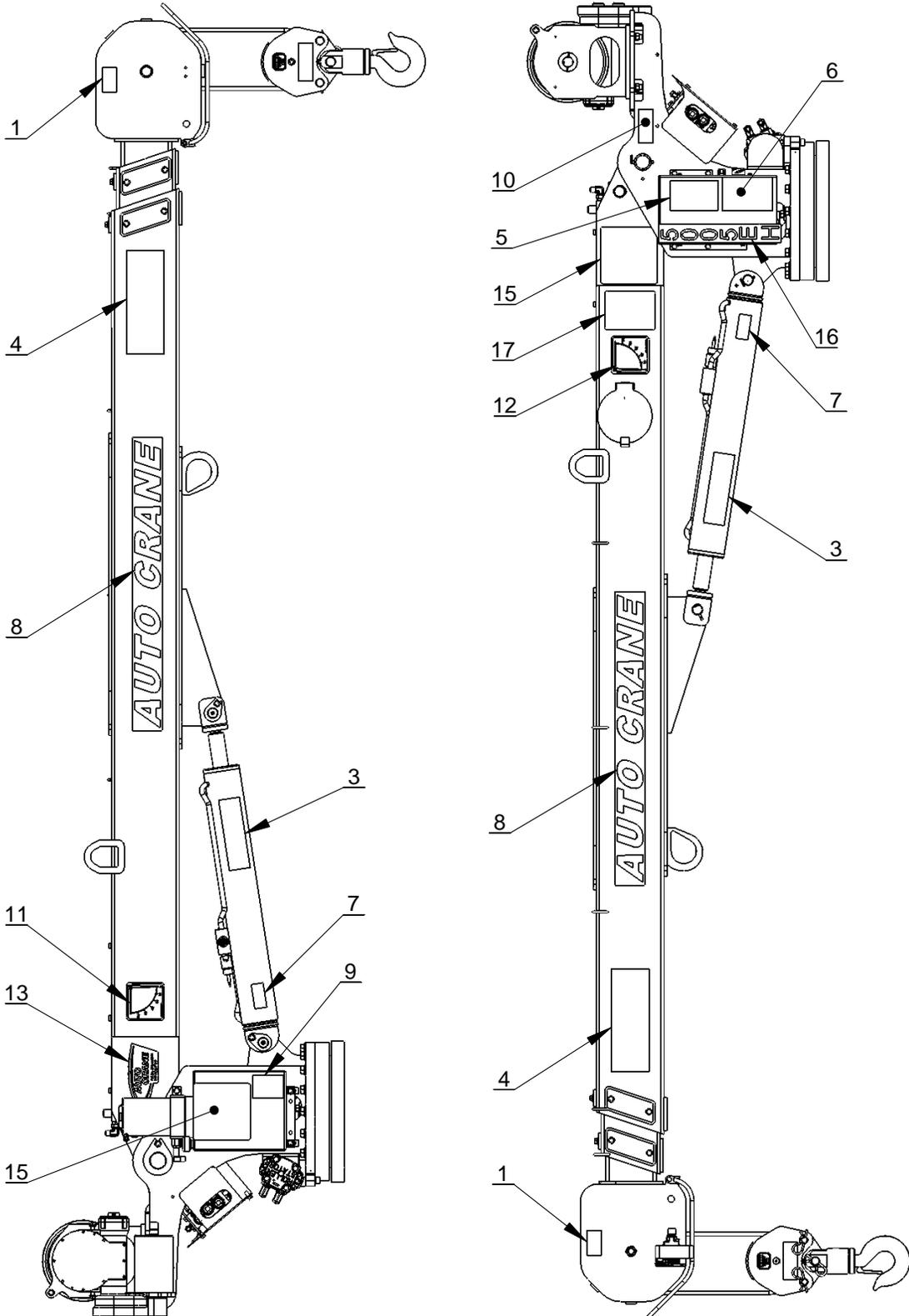

5005EH DECAL LAYOUT

P/N: 360682000

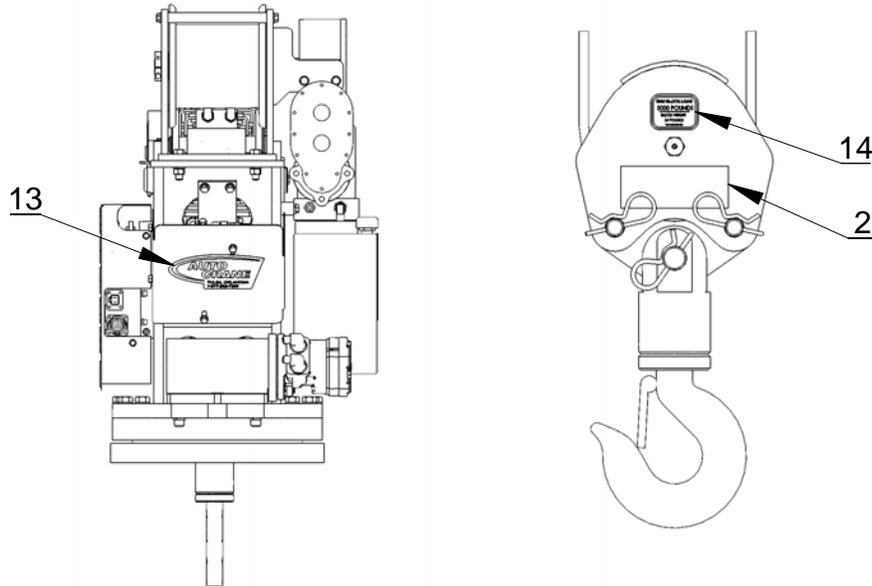

ITEM NO.	QTY.	PART NO.	DESCRIPTION
1	2	040517000	DECAL STAY CLEAR OF BOOM
2	2	040518000	DECAL STAY CLEAR OF LOAD
3	2	040519000	DECAL DANGER SCISSOR POINT
4	2	040529000	DECAL DANGER "ELECTROCUTION HAZARD" POWER LINE
5	1	040579000	DECAL OPERATION INSTRUCTIONS
6	1	040580000	DECAL TRAINED OPERATOR
7	2	040587000	DECAL WARNING LOAD SENSOR
8	2	040624000	DECAL AUTO CRANE
9	1	040632000	DECAL WARNING - OVERLOAD
10	1	330622000	DECAL SERIAL NO
11	1	320318000	DECAL ANGLE INDICATOR CS
12	1	320318001	DECAL ANGLE INDICATOR SS
13	2	360034000	DECAL AUTO CRANE LOGO
14	2	360480100	DECAL, MAX LOAD BLOCK 5005H/EH
15	2	360838000	LOAD CHART, 5005EH
16	1	360839000	DECAL 5005EH
17	1	460169000	DECAL WARNING, REMOTE CONTROL

5005EH-24V CONTROL GENERAL DIMENSIONS

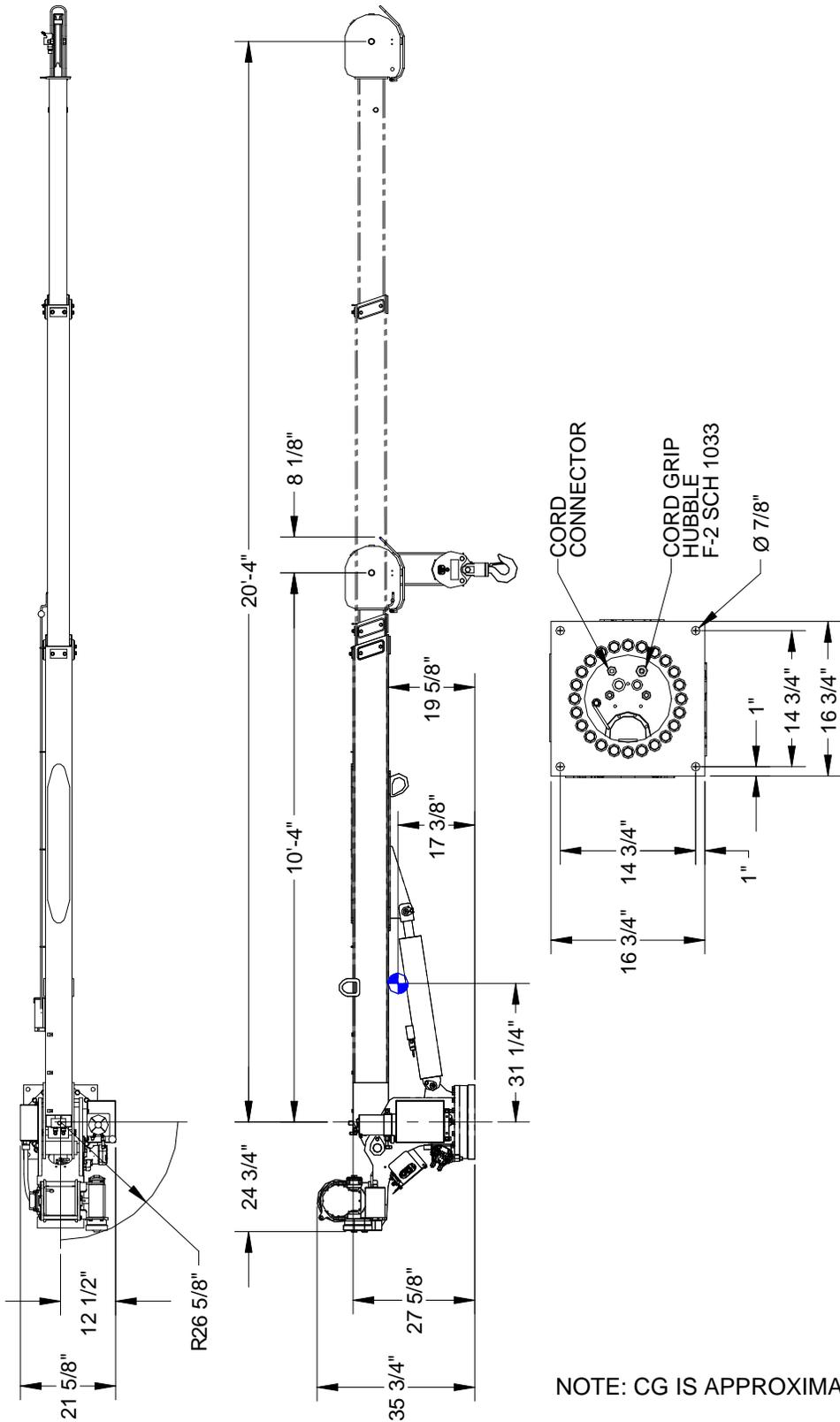

NOTE: CG IS APPROXIMATE

5005EH-24V CONTROL MOUNTING AND INSTALLATION

1. Check to make sure the following items are with your crane.

ITEM	QTY	PART NO.	DESCRIPTION
1	4	015100000	SCREW, HX. HD, 7/8-14NF X 5" LG. GRADE 8
2	4	022200000	WASHER, SP. LK. 7/8
3	4	018900000	NUT, HEX 7/8-14NF
4	6	083800000	CLIP, CABLE #838 (FRAME)
5	1	999955001	MANUAL, 5005EH-24V CONTROL
6	1	680175000	MASTER DISCONNECT SWITCH
7	1	366709001	PENDANT

2. Vehicle should meet minimum GVW rating of 14,500 pounds. (does not include bodies or accessories)
3. Make sure mounting surface is properly reinforced to withstand 25,000 ft-lb capacity loading of crane and that outriggers are used to provide total stability for the truck.
4. A 12" dia. hole should be cut out of mounting location (centered with mounting bolts) for access. Reference general dimensions for bolt pattern.
5. Make sure the mounting bolts are 7/8" dia, grade 8UNF. Torque bolts to 501 ft-lbs (dry).
6. When crane is not in operation, a boom support should always be used. Traveling block should be connected to hook loop.
7. Install Voltage switching unit inside compartment safe from weather and contamination. See following page for installation.
8. See the following pages for additional electrical installation.
9. Load test the crane to ensure proper functioning and truck stability
10. Make certain the owner's manual is delivered to the customer.
11. For additional help: call the service department at the Auto Crane Company. (918) 836-0463 (Tulsa, Oklahoma)

WARNING

FEDERAL LAW (49 CFR PART 571) REQUIRES THAT THE FINAL STAGE MANUFACTURER OF A VEHICLE CERTIFY THAT HE VEHICLE COMPLIES WITH ALL APPLICABLE FEDERAL REGULATIONS. ANY MODIFICATIONS PERFORMED ON THE VEHICLE PRIOR TO THE FINAL STAGE ARE ALSO CONSIDERED INTERMEDIATE STAGE MANUFACTURING AND MUST BE CERTIFIED AS TO COMPLIANCE. THE INSTALLER OF THIS CRANE AND BODY IS CONSIDERED ONE OF THE MANUFACTURERS OF THE VEHICLE. AS SUCH A MANUFACTURER, THE INSTALLER IS RESPONSIBLE FOR COMPLIANCE WITH ALL APPLICABLE FEDERAL AND STATE REGULATIONS, AND IS REQUIRED TO CERTIFY THAT THE VEHICLE IS IN COMPLIANCE.

IT IS THE FURTHER RESPONSIBILITY OF THE INSTALLER OF THE CRANE TO COMPLY WITH THE OSHA TRUCK CRANE STABILITY REQUIREMENTS AS SPECIFIED BY 29 CFR PART 1910.180 (C) (1).

5005EH-24V CONTROL GENERAL ASSEMBLY HARDWIRED P/N: 360645004

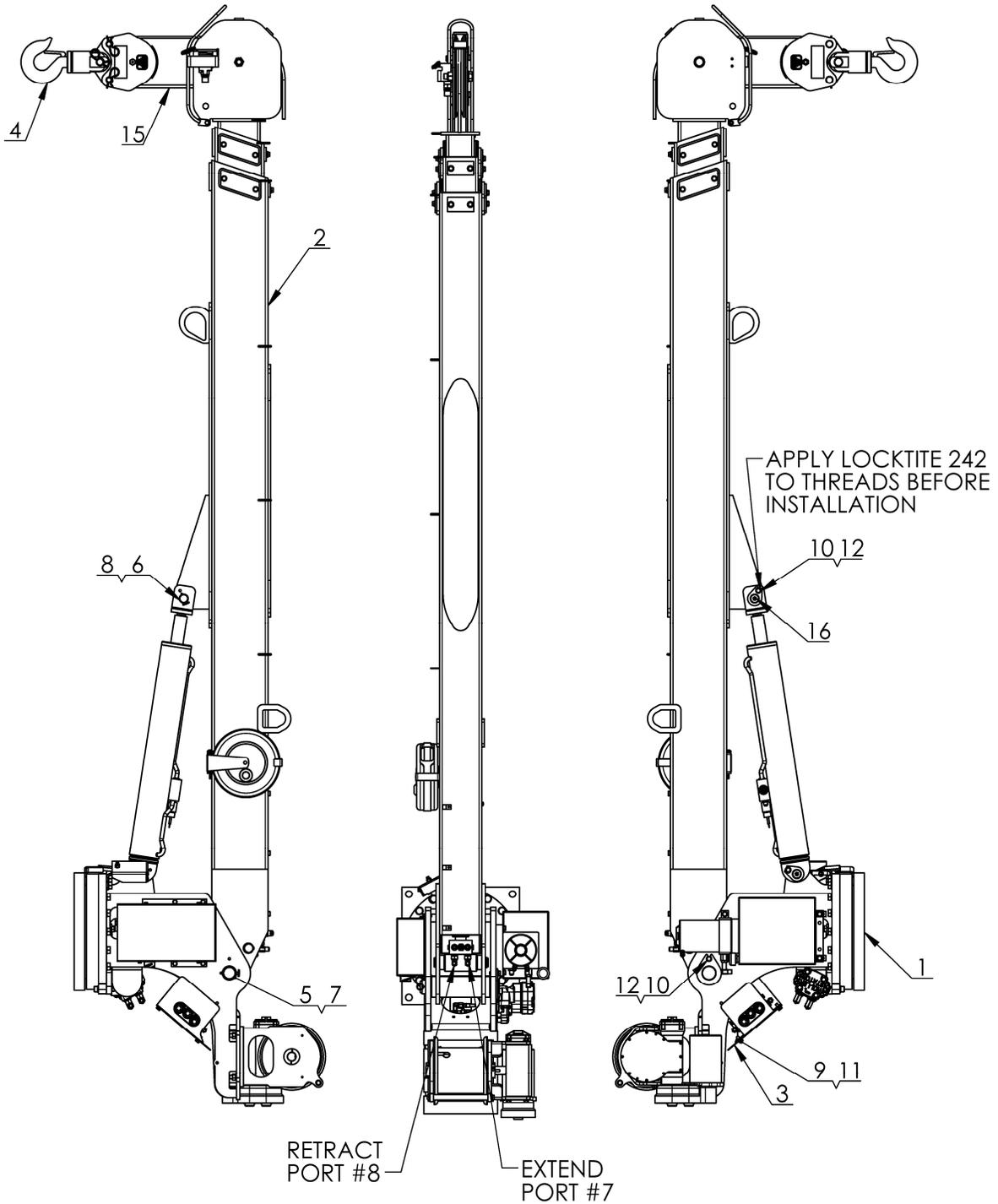

HYDRAULIC SCHEMATIC P/N: 366785000

**5005EH-24V CONTROL
GENERAL ASSEMBLY HARDWIRED
P/N: 360645004**

ITEM NO.	QTY.	PART NO.	DESCRIPTION
1	1	360648002	PEDESTAL ASSEMBLY 5005EH W/ ROTATION STOP & 24V CNTRL
2	1	360647000	BOOM ASSY
3	1	366688000	COVER, REAR
4	1	360644000	TRAVELING BLOCK ASSY, 5005H/EH
5	1	360675000	PIN, BOOM PIVOT
6	1	360676000	PIN, CYLINDER
7	1	360677000	PIN, 1/4 COTTERLESS RING
8	1	360678000	PIN, 3/16 COTTERLESS RING
9	2	07807000	SCREW HX HD 5/16-18UNC X 3/4 LG GR5
10	2	8702000	SCREW HX HD 3/8-16UNC X 1 1/4 LG GR5
11	2	20601000	WASHER SP LK 5/16
12	2	021100000	WASHER SP LK 3/8
13	1	360682000	DECAL LAYOUT 5005EH
14	1	360683004	SHIP KIT 5005EH - HW WITH ROTATION STOP & 24V CNTRL
15	1	360155000	ROPE ASSY
16	1	239300	ZERK, GREASE

5005EH-24V CONTROL PEDESTAL ASSEMBLY P/N: 360648002

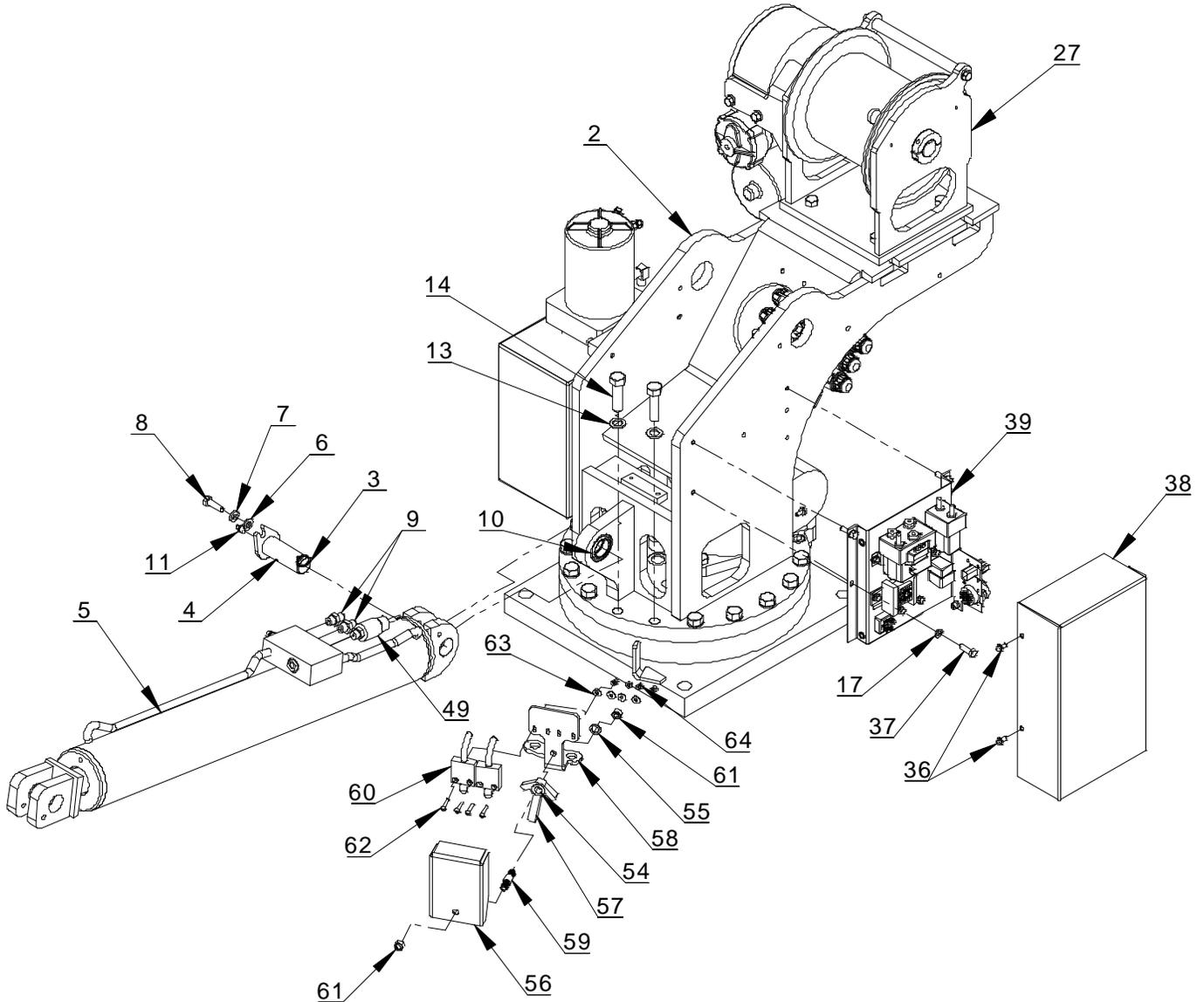

HYDRAULICS:
 PORT B-1 RETRACT
 PORT B-2 BOOM UP
 PORT B-3 CCW REAR MOTOR
 PORT A-1 EXTEND
 PORT A-2 BOOM DOWN
 PORT A-3 CC FRONT MOTOR

CYLINDER SEAL KIT: 360681001 (THI)
 CYLINDER SEAL KIT: 360681001 (CTD)
 C'BAL CARTRIDGE: 480188000

5005EH-24V CONTROL PEDESTAL ASSEMBLY P/N: 360648002

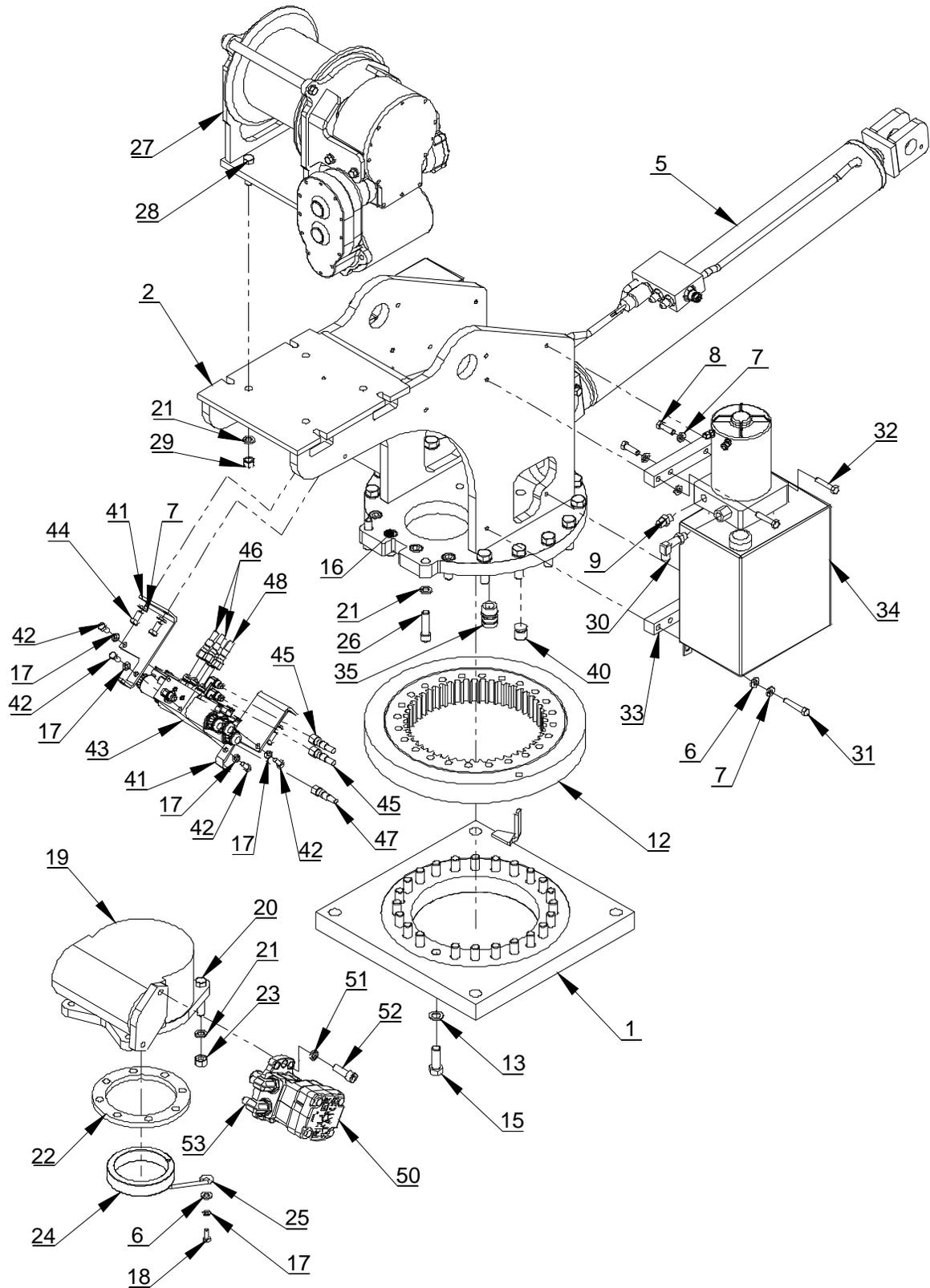

5005EH-24V CONTROL PEDESTAL ASSEMBLY P/N: 360648002

ITEM NO.	QTY.	PART NO.	DESCRIPTION
1	1	366721000	BASE PLATE WELDMENT
2	1	366642000	PEDESTAL WELDMENT
3	1	360678000	PIN, 3/16 COTTERLESS RING
4	1	360676000	PIN, CYLINDER
5	1	360681000	CYLINDER, LIFT
6	4	320976000	WASHER, FLAT, 3/8 SAE HARDENED
7	11	021100000	WASHER SP LK 3/8
8	3	008702000	SCREW HX HD 3/8-16UNC X 1 1/4 LG GR5
9	3	200876000	FITTING 6 SAE/6 JIC STRAIGHT
10	1	366333000	BEARING, SPHERICAL 1.25 ID
11	1	239300000	ZERK, GREASE
12	1	480023002	BEARING, ROTATION
13	38	023902000	WASHER FL 5/8 HARDENED
14	14	490171000	SCREW HX HD 5/8-11UNC X 2 1/4 LG GR8
15	24	012198000	SCREW HX HD 5/8-11UNC X 1 3/4 LG GR8
16	4	006205000	SCREW SOC HD 5/8-11UNC X 1 1/4 LG
17	9	020601000	WASHER SP LK 5/16
18	1	007807000	SCREW HX HD 5/16-18UNC X 3/4 LG GR5
19	1	160407	GEAR BOX, ROTATION
20	2	011202000	SCREW HX HD 1/2-20UNF X 2 3/4 LG GR5
21	8	021500000	WASHER SP LK 1/2
22	1	480011000	SEAL ROTATION BOX
23	2	017704000	NUT HX HVY 1/2-20UNF
24	1	360162000	RING, ECCENTRIC
25	1	360207000	RETAINER ECCENTRIC RING
26	2	009118000	SCREW SOC HD 1/2-13UNC X 2 LG
27	1	113001	HOIST ASSEMBLY
28	4	011608000	SCREW HX HD 1/2-13UNC X 2 LG
29	4	017701000	NUT HX 1/2-13UNC
30	1	330645000	FITTING 90 6-SAE/6-JIC LONG
31	2	009116000	SCREW HX HD 3/8-16UNC X 2 GR5
32	2	460113000	SCREW HX HD 3/8-16UNC X 1-3/4 LG GR8
33	2	366651000	BAR, POWER UNIT MOUNT
34	1	366650000	HYDRAULIC POWER UNIT
35	1	366698000	CORD GRIP .375-.500 3/4" HUB
36	4	360493000	SCREW HX WHIZ-LK 1/4-20UNC X 1/2 LG
37	4	007400000	SCREW HX HD 5/16-18UNC X 1 LG GR5
38	1	366687000	COVER, RELAY PANEL
39	1	366682001	RELAY PANEL ASSY, 24V CONTROL

**5005EH-24V CONTROL
PEDESTAL ASSEMBLY P/N: 360648002**

ITEM NO.	QTY.	PART NO.	DESCRIPTION
40	1	642908000	CORD CONNECTOR
41	2	366653000	BRACKET, VALVE MOUNT
42	4	330252000	SCREW HX HD 5/16-18UNC X 3/4 LG GR5
43	1	320826004	VALVE ASSEMBLY, 24V CONTROL
44	4	008400000	SCREW HX HD 3/8-16UNC X 3/4 LG GR 5
45	2	812026018	HOSE ASSY -4 HOSE -6 FEMALE JIC
46	3	812026016	HOSE ASSY -4 HOSE -6 FEMALE JIC
47	1	812026014	HOSE ASSY -4 HOSE -6 FEMALE JIC
48	2	812026031	HOSE ASSY -4 HOSE -6 FEMALE JIC
49	1	360685000	LOAD SENSOR SWITCH, 2400 PSI
50	1	320930000	MOTOR, HYDRAULIC WHITE 6.3 IN ³
51	2	021502000	WASHER SP LK 1/2 HI COLLAR
52	2	012197000	SCREW SOC HD 1/2-13UNC X 1/2 LG
53	2	490198000	FITTING 10SAE(M)/6JIC ELBOW 90
54	1	460079000	BEARING, ROTATION STOP
55	1	366675000	WASHER, NYLON
56	1	366676000	COVER, ROTATION STOP
57	1	366671000	ARM, ROTATION STOP
58	1	366672000	BRACKET, ROTATION STOP
59	1	366673000	PIN, ROTATION STOP
60	1	460110000	ROTATION STOP SWITCH ASSEMBLY
61	2	017301000	NUT HX NYLK 3/8-16UNC CP
62	4	460093000	SCREW RD HD SL #10-24UNC X 1 LG ZP
63	4	020000000	WASHER FL #10 ZP
64	4	015801000	NUT HX NYLON LOCK #10-24UNC ZP

5005EH-24V CONTROL BOOM ASSEMBLY P/N: 360647000

ITEM NO.	QTY.	PART NO.	DESCRIPTION
1	1	360666000	UPPER BOOM WELDMENT
2	1	360789000	CYLINDER EXTENSION
3	1	366198000	SHEAVE ASSY 3/8
4	4	366696000	COVER, SIDE WEAR PAD
5	12	021100000	WASHER SP LK 3/8
6	20	008400000	SCREW HX HD 3/8-16UNC X 3/4 LG GR 5
7	2	366184000	RETAINER EXTENSION CYLINDER
8	1	366193000	PIN 1 X 7.66 LG
9	2	360793000	BEARING PIVOT
10	6	360767000	PAD BOOM 1.5 O.D.
11	1	360765000	WEAR PAD 2 .50 X 3 .25
12	1	360712000	PIN 1 X 4.33 LG
13	1	646900000	SWITCH, LIMIT ANTI-TWO BLOCK
14	1	360718000	BAIL WELDMENT
15	2	200876000	FITTING 6 SAE/6 JIC STRAIGHT
16	2	480194000	FITTING 6 SWIVEL NUT ELBOW
17	1	366333000	BEARING, SPHERICAL 1.25 ID
18	2	366201000	WEAR PAD 3 .75 X 2.00 X .313
19	2	366483000	PLATE, WEAR PAD .25 X 2 X 4
20	4	021200000	WASHER FL 3/8
21	4	008800000	SCREW HX HD 3/8-24UNF X 1 LG
22	1	007803000	SCREW HX HD 5/16-18UNC X 3-1/2 LG GR5
23	1	016801000	NUT HX NYLK 5/16-18UNC CP
24	1	360759001	CORD REEL ASSY
25	1	022102000	WASHER FL 3/4
26	1	360756000	NUT, HX NYLK 3/4-10UNC
27	1	642918000	CORD CONNECTOR
28	1	366678000	SPRING, EXTENSION
29	1	367366000	SCREW HX HD 3/4-10UNC X 3-1/2 LG
30	2	480029000	RING RETAINING
31	2	360122000	RING RETAINING 5100-98
32	1	360665000	MID BOOM WELMENT
33	1	360674000	PLATE WEAR PAD RETAINER
34	6	366666000	WEAR PAD, SIDE
35	1	360664000	BOOM WELD LOWER 5005
36	1	366648000	WEAR PAD, BOTTOM UPPER

5005EH-24V CONTROL ROTATION GEARBOX P/N: 160407

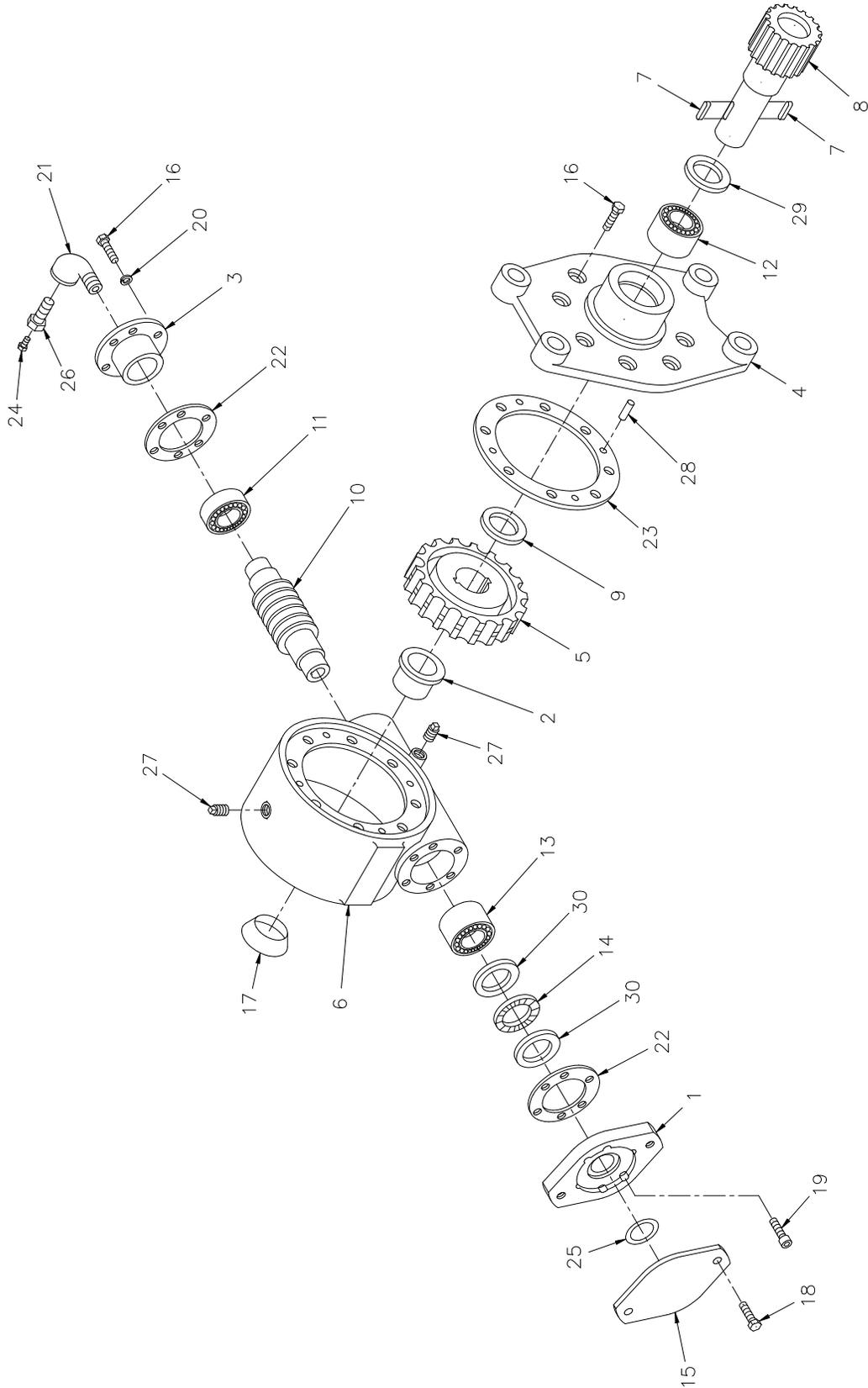

5005EH-24V CONTROL ROTATION GEARBOX P/N: 160407

ITEM NO.	QTY.	PART NO.	DESCRIPTION
1	1	300058	ADAPTER
2	1	308085	BUSHING
3	1	316092	CAP BEARING
4	1	328126	COVER
5	1	334016	GEAR R.H.
6	1	338261	HOUSING GEAR
7	2	342120	KEY
8	1	357139	SHAFT OUTPUT
9	1	366019	WASHER THRUST
10	1	368183	WORM R.H.
11	1	402044	BEARING BALL
12	1	402105	BEARING NEEDLE
13	1	402106	BEARING NEEDLE
14	1	402107	BEARING THRUST
15	1	413013	COVER
16	14	414146	SCREW HX HD 5/16 NC X 1 1/4 GR5 (NYLON HEAVY PATCH)
17	1	530101	PLUG - EXPANSION
18	2	414581	SCREW HX HD 1/2 NC X 3/4 GR5
19	6	414869	SCREW SOC HD 5/16 NC X 1
20	6	418163	WASHER LK 5/16 MED SECT
21	1	432011	ELL 90 DEG
22	2	442182	GASKET
23	1	442187	GASKET
24	1	456008	FITTING RELIEF
25	1	462029	O-RING
26	1	468002	REDUCER
27	2	468018	PLUG PIPE
28	4	470062	PIN DOWEL
29	1	486071	SEAL OIL
30	2	518026	WASHER THRUST

5005EH ACTUATOR ASSEMBLY

P/N: 297025

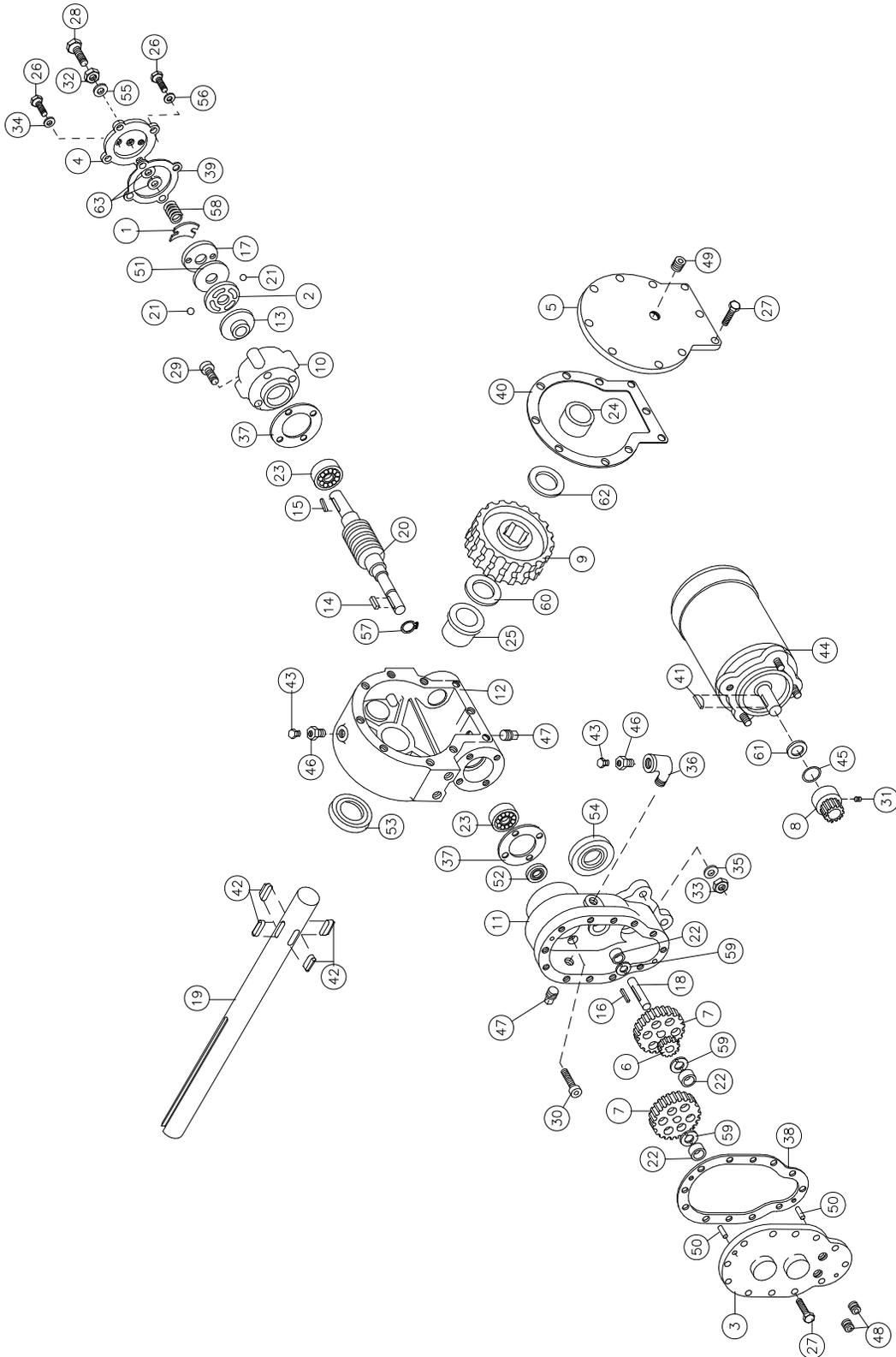

5005EH ACTUATOR ASSEMBLY

P/N: 297025

ITEM NO.	QTY.	PART NO.	DESCRIPTION
1	1	306034	SPRING - FLAT
2	1	314008	PLATE - CAM
3	1	328106	COVER - SPUR GEAR HSG.
4	1	328128	COVER - BRAKE
5	1	328134	COVER - WORM GEAR HSG.
6	1	334001	IDLER GEAR
7	2	334003	SPUR GEAR
8	1	334129	PINION GEAR
9	1	334163	GEAR - WORM., R.H.
10	1	338007	HOUSING - BRAKE
11	1	338203	SPUR GEAR HOUSING
12	1	338273	GEAR HOUSING
13	1	340002	HUB - BRAKE
14	1	342023	KEY - SQ. END
15	1	342027	KEY - RD. END
16	1	342033	KEY - SQ. END
17	1	352022	PLATE - RETAINER
18	1	356901	SHAFT - SPUR
19	1	357145	SHAFT - OUTPUT
20	1	368022	WORM - R.H. 46:1
21	2	400003	BALL
22	3	402001	BEARING - NEEDLE
23	2	402002	BEARING - BALL
24	1	412044	BUSHING - COVER
25	1	412045	BUSHING - HOUSING
26	6	414021	SCW HH 1/4-20 X 1 GR 8 NYLOK HVY PATCH
27	22	414038	SCW HH 1/4-20 X 3/4 GR 5
28	1	414224	SCW HH 3/8-16 X 1-1/2 GR 5 FULL THD
29	4	414821	SCW BTN HD SOC 1/4-20 X 7/8
30	4	414845	SCW 1/4-20 X 1 SOC HD LOC-WEL
31	1	416029	SETSCREW
32	1	418036	NUT JAM 3/8-16
33	3	418040	NUT 3/8-24
34	2	418154	WASHER 1/4 FLAT ALUM.
35	3	418177	LOCKWASHER
36	1	432011	ELBOW 90 DEGREE

5005EH ACTUATOR ASSEMBLY

P/N: 297025

ITEM NO.	QTY.	PART NO.	DESCRIPTION
37	2	442184	GASKET
38	1	442185	GASKET
39	1	442189	GASKET
40	1	442205	GASKET
41	1	450001	KEY - WOODRUFF
42	4	450016	KEY - BARTH
43	2	456008	RELIEF FITTING
44	1	458005	MOTOR - 24V
45	1	462015	O-RING
46	2	468002	REDUCER
47	2	468011	PIPE PLUG SQ HD
48	2	468017	PIPE PLUG SOC HD
49	1	468018	PIPE PLUG SOC HD
50	2	470001	PIN
51	1	474001	PLATE - THRUST
52	1	486009	OIL SEAL
53	1	486017	OIL SEAL
54	1	486023	OIL SEAL
55	1	486069	THREAD SEAL
56	4	486070	THREAD SEAL
57	1	490003	SNAP RING
58	1	494007	SPRING
59	3	518002	THRUST WASHER
60	1	518015	THRUST WASHER
61	1	518018	FIBER WASHER
62	1	518040	WASHER - THRUST
63	2	418181	WASHER, FLAT 3/8 SAE

NOTES

**5005EH-24V CONTROL
TRAVELING BLOCK ASSEMBLY
P/N: 360644000**

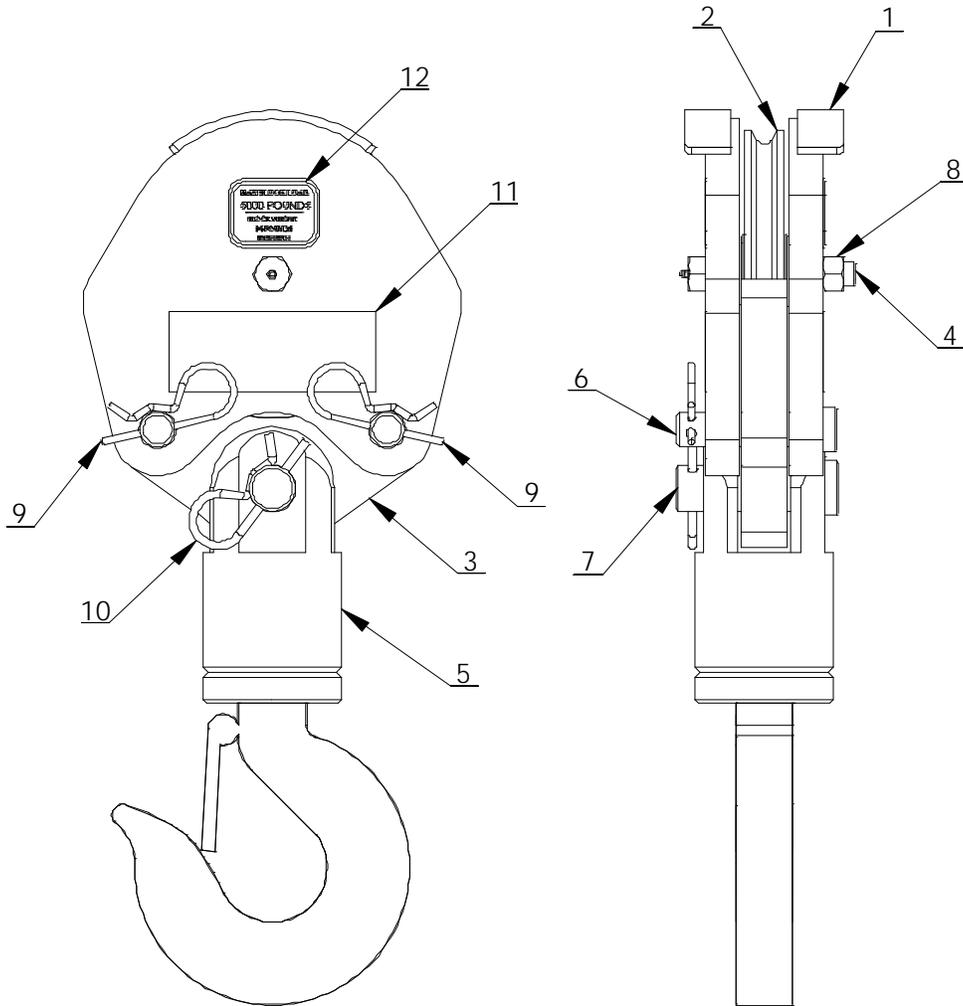

**5005EH-24V CONTROL
TRAVELING BLOCK ASSEMBLY
P/N: 360644000**

ITEM NO.	QTY.	PART NO.	DESCRIPTION
1	2	480362000	SHORT BLOCK SIDE PL WDMT
2	1	480130000	SHEAVE ASSY
3	1	480364000	TACKLE LOWER
4	1	480372000	BOLT, SHEAVE W/ ZERK FITTING
5	1	480371000	HOOK SWIVEL 3 METRIC TON
6	2	480367000	PIN BLOCK
7	1	480368000	PIN SWIVEL HOOK
8	1	017800000	NUT, HX LK 1/2-20UNF
9	2	366813000	PIN HITCH
10	1	360124000	PIN HITCH
11	2	040518000	DECAL STAY CLEAR OF LOAD
12	2	360480100	DECAL, MAX LOAD BLOCK 5005H/EH

5005EH-24V CONTROL RELAY PANEL ASSEMBLY P/N: 366682001

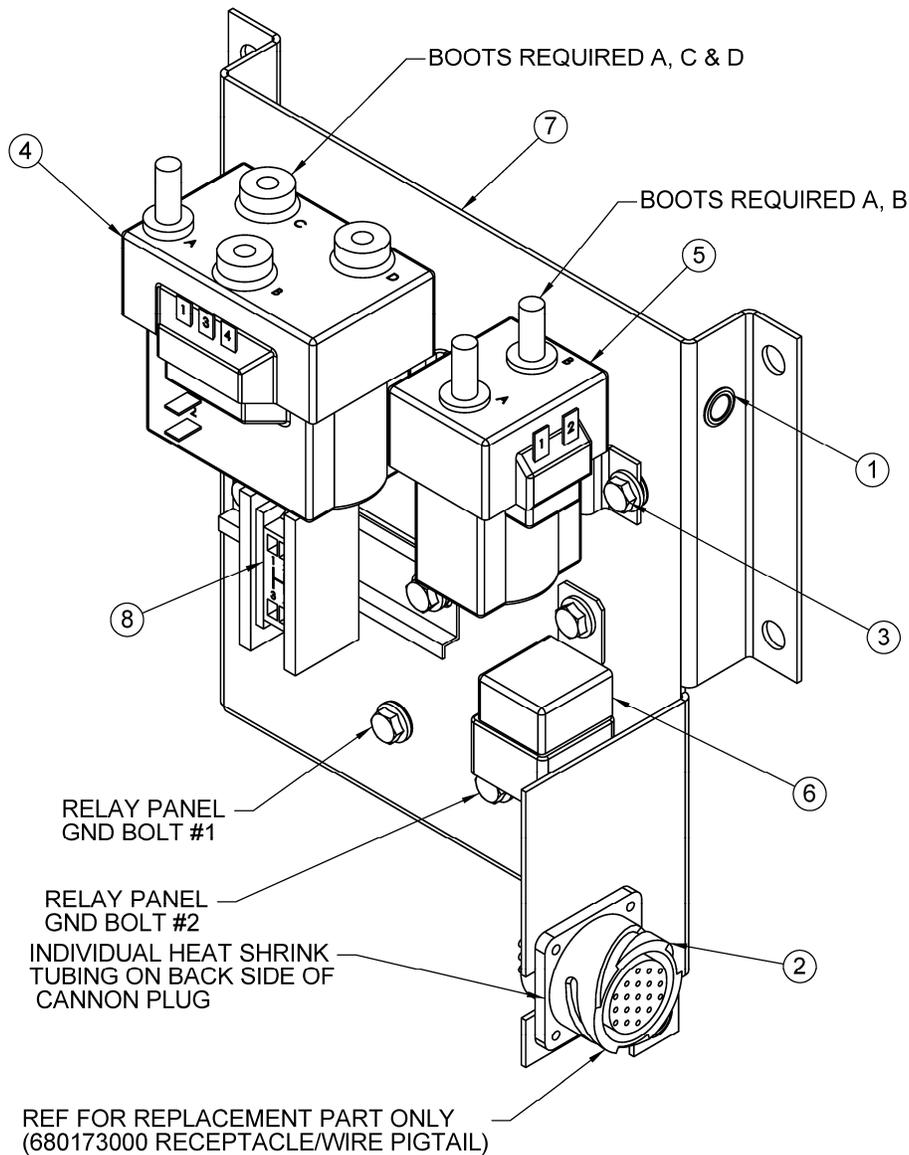

ITEM NO.	QTY.	PART NO.	DESCRIPTION
1	13	736272	NUTSERT 1/4-20UNC X .027-.165 GRIP
2	1	366095	PLUG, 19 PIN
3	9	360493000	SCREW HX WHIZ-LK 1/4-20UNC X 1/2 LG
4	1	320589001	RELAY DOUBLE SEALED 24V COIL
5	1	320584001	RELAY SINGLE SEALED 24V COIL
6	1	320355001	RELAY, DROP-OUT 24V CNTRL
7	1	366683001	BACK PANEL, RELAY PANEL
8	1	366708001	TERMINAL BLOCK ASSEMBLY

5005EH-24V CONTROL PENDANT 8 FUNCTION W/ ON/OFF SWITCH P/N: 366709001

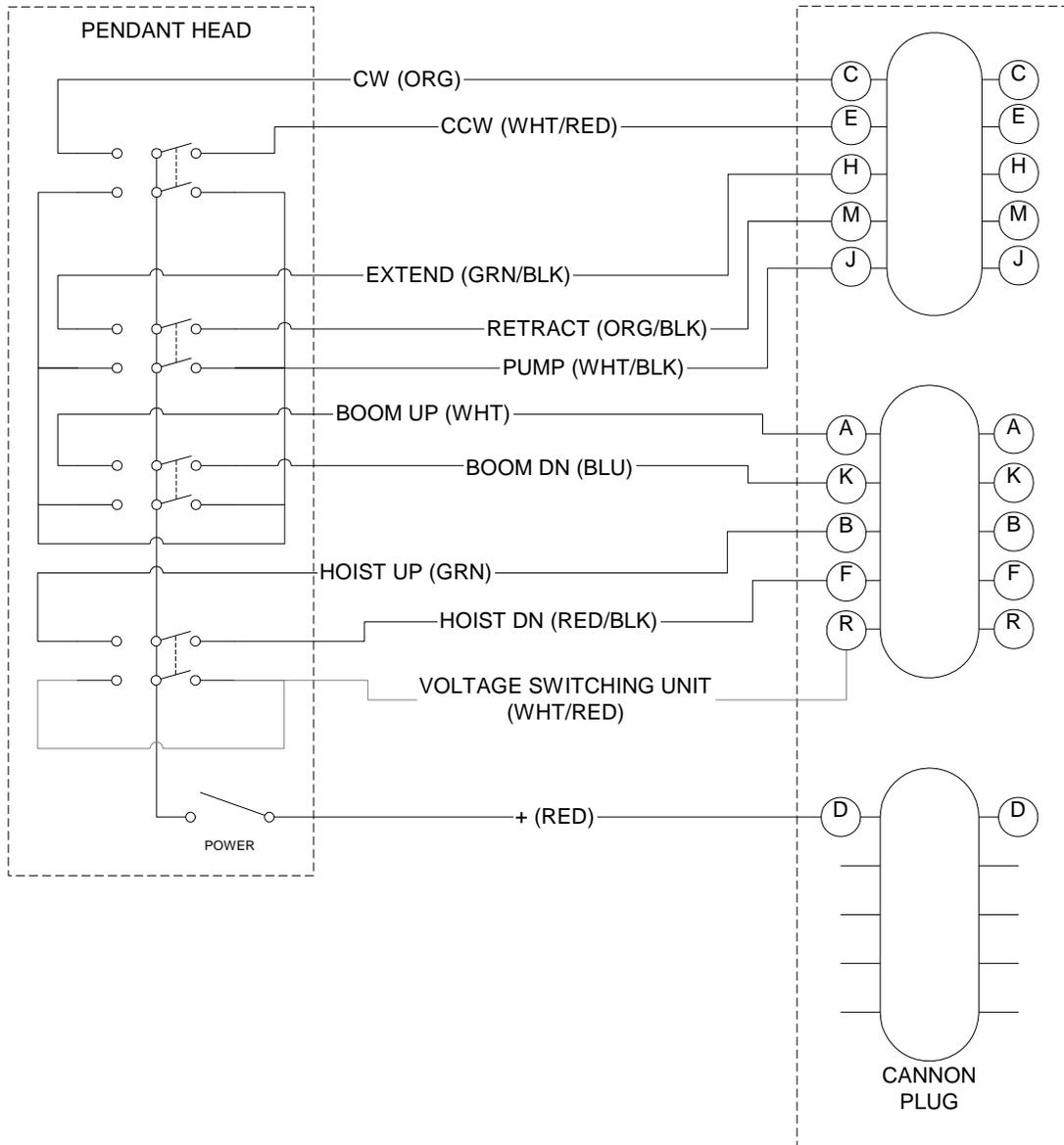

5005EH PENDANT 8 FUNCTION W/ ON/OFF

P/N: 366709001

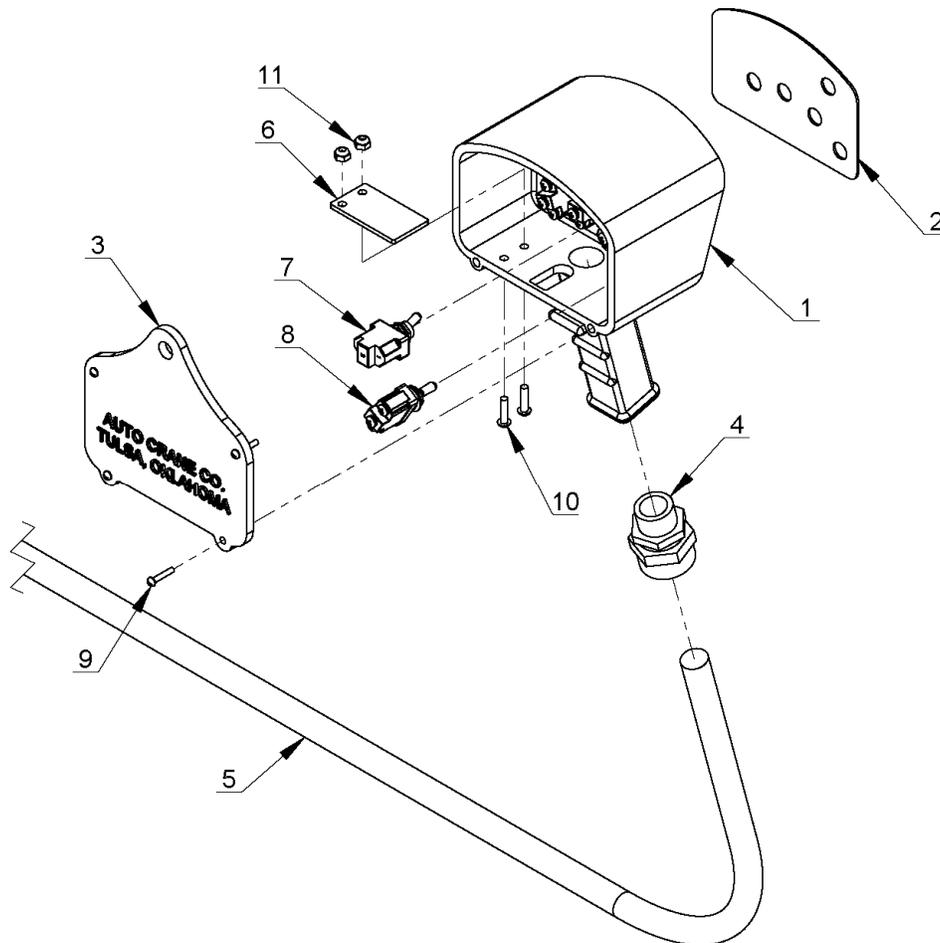

ITEM NO.	QTY.	PART NO.	DESCRIPTION
1	1	480501000	PENDANT HOUSING
2	1	366719000	DECAL, PENDANT 8 FUNC W/PWR
3	1	480504000	PENDANT BACK PLATE
4	1	370433000	CORD GRIP, 3/4 NPT, .50-.625" CORD
5	1	680172000	PENDANT CABLE
6	1	480598000	COVER TRIGGER OPENING
7	1	750090000	TOGGLE SWITCH (ON-OFF)
8	4	634200000	TOGGLE SWITCH KIT
9	4	001004000	SCREW PN HD #6 X 3/4 LG
10	2	002607000	SCREW RD HD #10-24UNC X 3/4 LG CP
11	2	015801000	NUT HX NYLK #10-24UNC ZP

5005EH-24V CONTROL HYDRAULIC SCHEMATIC P/N: 366785000

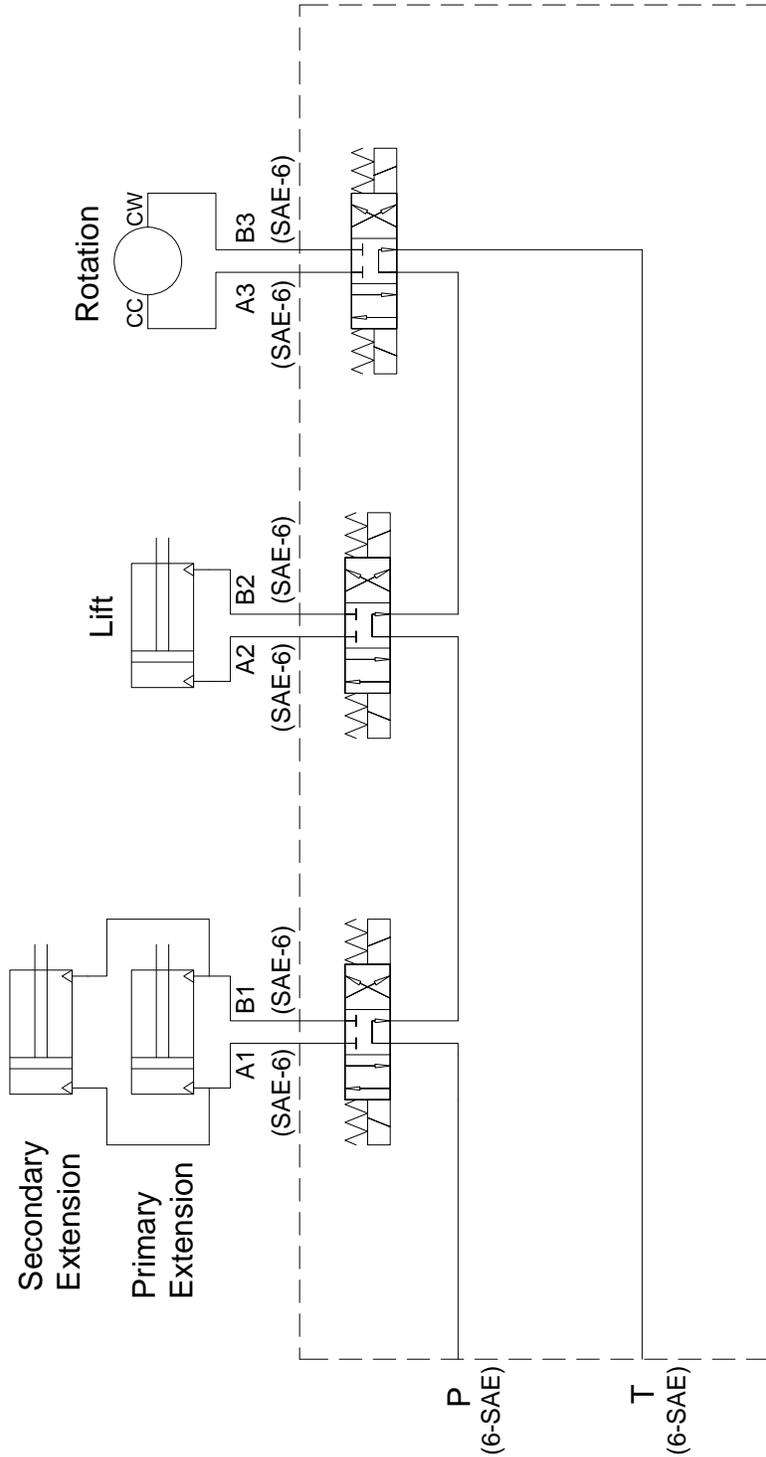

5005EH-24V CONTROL HYDRAULIC CONTROL VALVE P/N: 320826004

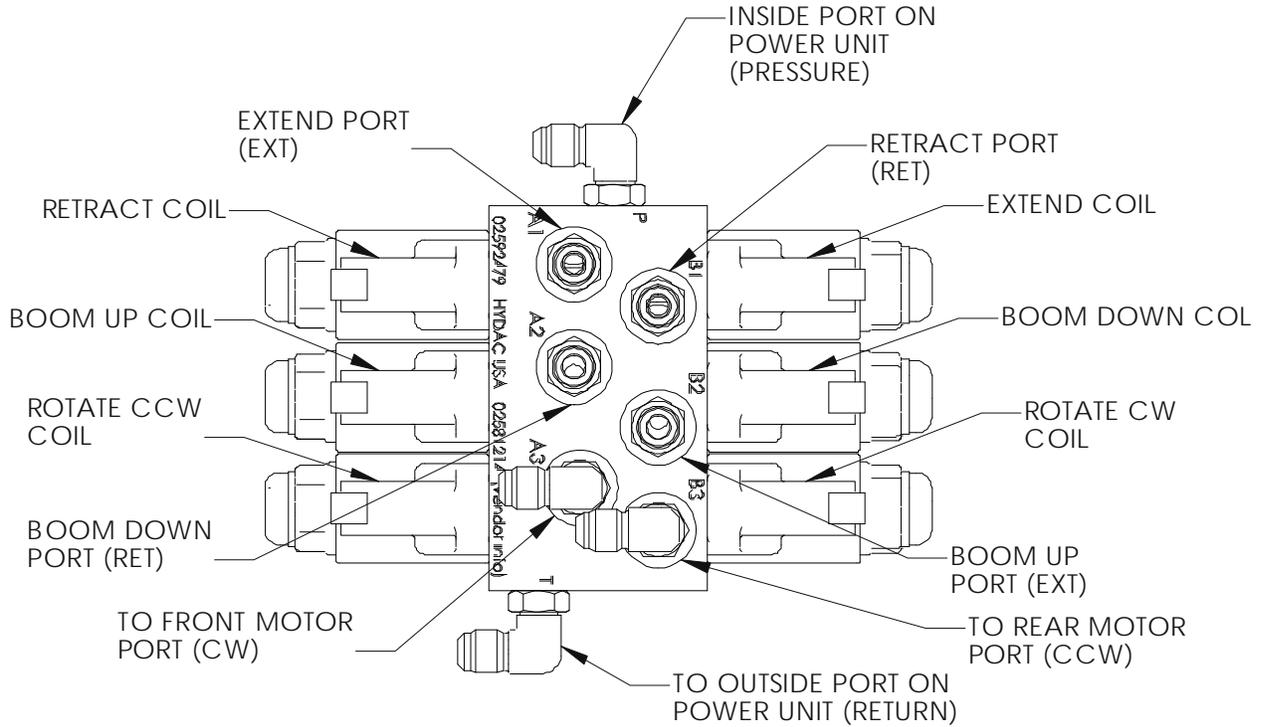

QTY	DESCRIPTION	A/C P/N
3	SPOOL VALVE, 4WK06G-12X-0-0-N	320826001
6	SOLENOID COIL, 24DN-50-1836	320826003

5005EH-24V CONTROL HYDRAULIC POWER UNIT P/N: 366650000

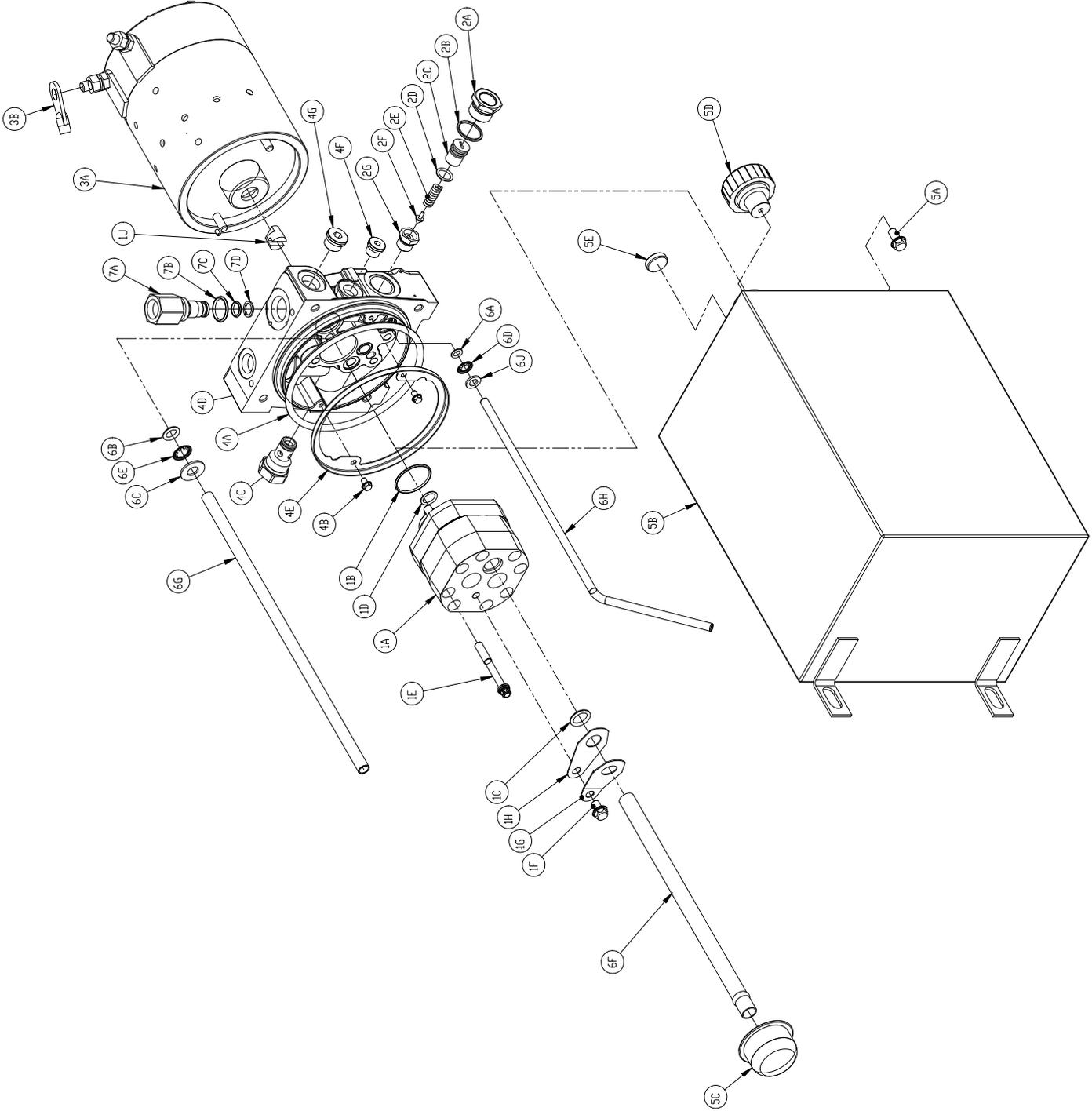

5005EH-24V CONTROL HYDRAULIC POWER UNIT P/N: 366650000

NOTE: SOME PARTS AVAILABLE ONLY IN THEIR RESPECTIVE KITS.

ITEM	PART NO.	DESCRIPTION	QTY.
1	360808001	PUMP AND PARTS	-
1A		PUMP ASSEMBLY	1
1B		O-RING	1
1C		O-RING	1
1D		O-RING	1
1E		SCREW	4
1F		SCREW	1
1G		LOCKING SPRING	1
1H		RETAINER	1
1J		COUPLING	1
2	366650001	RELIEF VALVE KIT	-
2A		CAP	1
2B		GASKET	1
2C		ADJ SCREW	1
2D		O-RING	1
2E		SPRING	1
2F		PLUNGER	1
2G		SEAT ASSEMBLY	1
3	366650002	MOTOR KIT	-
3A		MOTOR 24V DC	1
3B		GROUND STRAP	1
4	366650004	ADAPTER KIT	-
4A		SEAL	1
4B		SCREW	2
4C		CHECK VALVE ASSEMBLY	1
4D		ADAPTER	1
4E		RETAINER	1
4F		PLUG	1
4G		PLUG	1
5	366650003	RESERVOIR KIT	-
5A		SCREW	4
5B		RESERVOIR	1
5C		STRAINER	1
5D	200545000	BREATHER	1
5E		MAGNET	1
6	366650004	TUBE KIT	-
6A		O-RING	1
6B		O-RING	1
6C		WASHER	1
6D		RETAINING RING	1
6E		RETAINING RING	1
6F		TUBE	1
6G		TUBE	1
6H		TUBE	1
6J		SPACER	1
7	320336002	RETURN PORT ASSEMBLY	-
7A		RETURN PORT BODY	1
7B		O-RING	1
7C		O-RING	1
7D		BACK-UP RING	1

NOTES

5005EH-24V CONTROL LOAD CHART P/N: 360838000

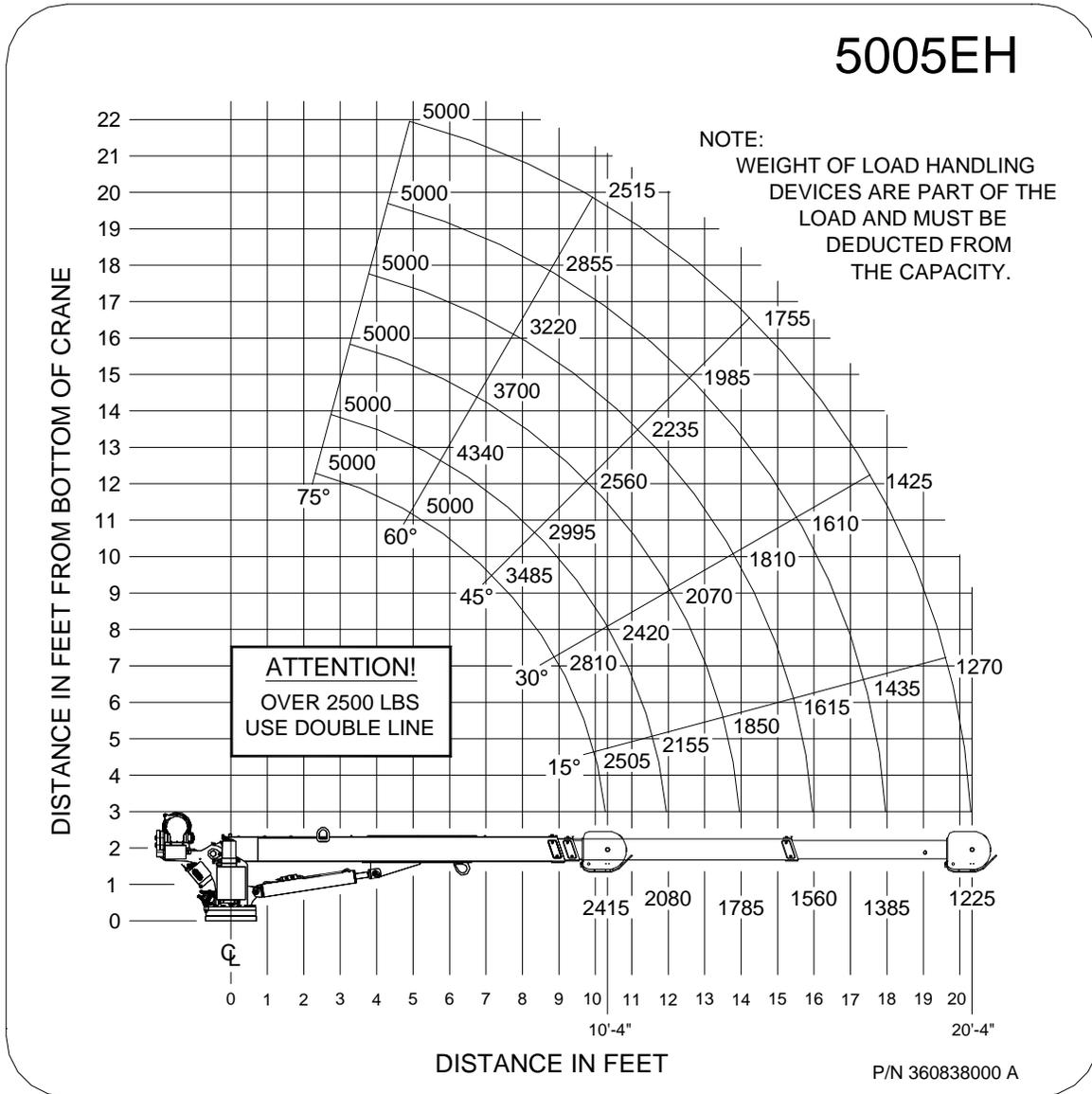

NOTES

CRANE PREVENTATIVE MAINTENANCE

PAINT FINISH PREVENTIVE MAINTENANCE INSTRUCTIONS

The paint finish on Auto Crane products can become damaged during normal use when chipped, scratched, exposed to harsh chemicals, cleaned with high pressure washers, etc. During periods when the truck is exposed to salt or other corrosive chemicals, Auto Crane products should be washed weekly. The paint finish should be inspected when washed or at least monthly. Any exposed bare metal or visible rust should be repaired immediately. Damaged paint on cranes should be repaired by:

1. Sanding the damaged areas to bare metal.
2. Solvent cleaning the sanded areas to remove sanding residue. Wipe dry with a clean cloth to remove any remaining residue.
3. Priming the sanded areas to a minimum of a 2 mil dry film thickness per the primer manufacturer's instructions. The primer must be compatible with Sherwin Williams' E2W932 epoxy primer.
4. Applying a 2 mil dry film thickness top coat paint per the manufacturer's instructions within 24 hours of applying the primer. The top coat paint must be compatible with Sherwin Williams' E2W932 epoxy primer and Sherwin Williams' Genesis polyurethane top coat paint. The final primer and top coat should have approximately a 4 mil dry film thickness.

NOTES



P.O. Box 580697 * Tulsa, OK 74158-0697
4707 N. Mingo Rd. * Phone (918) 836-0463

LIMITED WARRANTY 2 YEAR PARTS AND LABOR

Auto Crane will warranty to the consumer for a period of (2) years parts and labor from the date of purchase. Each new Auto Crane unit they sell will be free under normal use and service from defects in material and workmanship. Date of purchase will be honored as the date indicated on the Bill of Sale, which must accompany the Warranty Registration and be on file with Auto Crane. Absent a valid Warranty Registration and appropriate documentation, the original date of manufacture, as indicated by the serial number on the product, will be used to determine the effective date of the 2 year warranty.

The obligation of Auto Crane under this warranty is limited to the replacement or repair of parts that appear to the manufacturer after review and/or inspection to be defective and paid flat rate labor for replacing defective parts. This warranty does not obligate Auto Crane to bear the travel time charges in connection with the replacement or repair of defective parts. Responsibility for customer's claims arising from misapplication, abuse, misuse or alteration of equipment or parts lies with the distributor or user and no warranty obligation is assumed in these circumstances by Auto Crane.

Auto Crane will in no event be liable for any consequential damages or contingent liabilities arising out of the failure of any Auto Crane Product or parts to operate properly.

Auto Crane makes no warranty in respect to component accessories, it being subject to the warranties of their respective manufacturers.

If field service, at the request of the distributor, is rendered and fault is found not to be with Auto Crane's product, the distributor shall pay the time and expense of the field representative.

Claims for service labor or other expenses that have incurred by the buyer without approval or authorization or Auto Crane will not be accepted.

When applying for warranty, claims may be handled by contacting your nearest authorized Auto Crane Distributor. All claims are to be filed in writing on an Auto Crane Warranty Claim Form.

AUTO CRANE COMPANY IS UNDER NO OLIGATION TO EXTEND THIS WARRANTY TO ANY CUSTOMER FOR WHICH AN AUTO CRANE DELIVERY REPORT FORM HAS NOT BEEN COMPLETED AND ON FILE WITH AUTO CRANE COMPANY

