

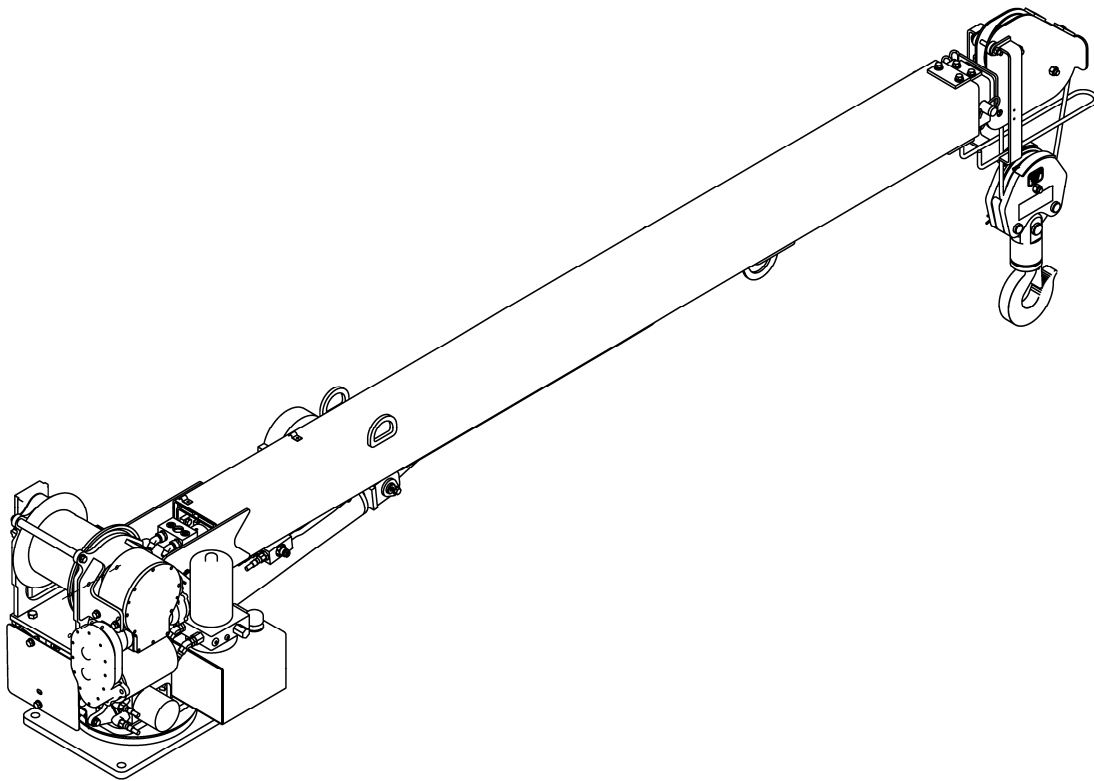

# 4004EH-20FT OWNERS MANUAL

Manual No. 404240015



**Serial No.** \_\_\_\_\_

**Mailing Address:**  
P.O. Box 580697  
Tulsa, OK 74158-0697  
**Physical Address:**  
4707 N. Mingo Rd.  
Tulsa, OK 74117-5904

**Phone (918) 836-0463**  
**Fax (918) 834-5979**  
<http://www.autocrane.com>



# Auto Crane Warranty Registration

Fax Transmission

To: Warranty Department Fax: (918) 834-5979  
 From: \_\_\_\_\_ Date: \_\_\_\_\_  
 Re: Product Registration Pages: \_\_\_\_\_

**End User Information:** (Required for Warranty Activation)

Name: \_\_\_\_\_ Phone: \_\_\_\_\_  
 Address: \_\_\_\_\_  
 City: \_\_\_\_\_ State: \_\_\_\_\_ Zip: \_\_\_\_\_  
 Contact: \_\_\_\_\_ E-mail Address: \_\_\_\_\_

**Distributor Information:** (Required for Warranty Activation)

Name: \_\_\_\_\_  
 Address: \_\_\_\_\_  
 City: \_\_\_\_\_ State: \_\_\_\_\_ Zip: \_\_\_\_\_  
 Contact: \_\_\_\_\_ E-mail Address: \_\_\_\_\_

**Product Information:** (Required for Warranty Activation)

Model No.: \_\_\_\_\_ Serial No.: \_\_\_\_\_  
 Date Product Delivered: \_\_\_\_\_ Date Processed:\* \_\_\_\_\_  
 VIN # \_\_\_\_\_ \* For Auto Crane use only

## ONE REGISTRATION FORM PER UNIT (CRANE OR BODY)

Registration form must be mailed or faxed within 15 days of customer installation.

Mail to:  
 Warranty Department  
 Auto Crane Company  
 P.O. Box 581510  
 Tulsa, OK 74158-0697

# 4004EH-20FT OWNER'S MANUAL REVISION RECORD

Revision Date	Section(s) Or Page(s)	Description of Change
11/4/09	6-10.0	Corrected Part Callout in exploded view
7/14/10	3-11	Added Brake Adjustment Page. Added Warranty
10/10/10	Sec. 6	Updated Assy. And BOMS to show new Power Unit

**Notes:**

1. The information contained in this manual is in effect at the time of this printing. It does not cover all instructions, configurations, accessories, etc. If you require additional information, please contact **Auto Crane Company** at **(918) 836-0463**.
2. **Auto Crane Company** reserves the right to update this material without notice or obligation.

# WARNINGS

**WARNING!** Federal law (49 cfr part 571) requires that the Final Stage Manufacturer of a vehicle certify that the vehicle complies with all applicable federal regulations. Any modifications performed on the vehicle prior to the final state are also considered intermediate stage manufacturing and must be certified as to compliance. The installer of this crane and body is considered one of the manufacturers of the vehicle. As such a manufacturer, the installer is responsible for compliance with all applicable federal and state regulations, and is required to certify that the vehicle is in compliance.

**WARNING!** It is the further responsibility of the installer to comply with the OSHA Truck Crane Stability Requirements as specified by 29 CFR part 1910.180 (C) (1).

**WARNING! NEVER OPERATE THE CRANE NEAR ELECTRICAL POWER LINES!**

**Death** or serious injury will result from boom, line, or load contacting electric lines. Do not use crane within 10 feet (3.05m) of electric power lines carrying up to 50,000 volts. One-foot additional clearance is required for every additional 30,000 volts or less. **SEE DANGER DECAL (P/N 040529)** in this Owner's Manual.

**WARNING! NEVER.....**

- ◆ **EXCEED** load chart capacities (centerline of rotation to hoist hook).
- ◆ Un-reel last 5 wraps of cable from drum!
- ◆ Wrap cable around load!
- ◆ Attempt to lift or drag a load from the side! The boom can fail far below its rated capacity.
- ◆ Weld, modify, or use unauthorized components on any Auto Crane unit! This will void any warranty or liability. Also failure of the crane may result.
- ◆ Place a chain link on the tip of the hook and try to lift a load!
- ◆ Use a sling bar or anything larger than the hook throat that could prevent the hook latch from closing, thus negating the safety feature!
- ◆ Hold on any pendant Select Switch that will cause unsafe operating conditions!

**WARNING!** In using a hook with latch, **ALWAYS** make sure that the hook throat is closed before lifting a load! Proper attention and common sense applied to the use of the hoist hook and various slings will prevent possible damage to material being hoisted and may prevent injury to personnel.

**WARNING!** Failure to correctly plumb and wire crane can cause inadvertent operation and damage to crane and/or personnel!

**WARNING!** Auto Crane Company remote controlled cranes are not designed or intended for use for any applications involving the lifting or moving of personnel.

**WARNING! ALWAYS** operate the crane in compliance with the load capacity chart. **DO NOT USE** the overload shutdown device to determine maximum rated loads, if the crane is equipped with this type of device.

**READ THIS PAGE**

# **4004EH**

## **TABLE OF CONTENTS**

INTRODUCTION	1-1.0
GENERAL SPECIFICATIONS	1-3.0
SAFETY TIPS AND PRECAUTIONS	2-1.0
OPERATING PRACTICES & WARNINGS	2-3.0
QUALIFICATIONS FOR OPERATORS	2-4.0
OPERATION OF UNIT / OUTRIGGERS	2-7.0
INSPECTION	3-1.0
TESTING	3-4.0
MAINTENANCE	3-5.0
BATTERIES	3-7.0
LUBRICATION AND MAINTENANCE SCHEDULE	3-9.0
WINCH BRAKE ADJUSTMENT	3-11.0
SAFETY DECAL SECTION	4-1.0
GENERAL DIMENSIONS	5-1.0
MOUNTING AND INSTALLATION	5-2.0
GENERAL ASSEMBLY, HARDWIRED	6-1.0
PEDESTAL ASSEMBLY	6-3.0
BOOM ASSEMBLY	6-7.0
HOIST ASSEMBLY	6-9.0
TRAVELING BLOCK ASSEMBLY	6-13.0
ELECTRICAL SECTION, HARDWIRED	7-1.0
PENDANT ASSEMBLY	7-3.0
HYDRAULIC SECTION	8-1.0
GENERAL ASSEMBLY, FM	9-1.0
FM CONTROL USE & CARE	10-1.0
TRANSMITTER ASSEMBLY, FM	10-2.0
ELECTRICAL SECTION, FM	10-3.0
FM, DIAGNOSTICS, TROUBLESHOOTING, AND ID PROG.	10-4.0
LOAD CHART	11-1.0
WARRANTY	LAST PAGE

# 4004EH

## INTRODUCTION

Auto Crane products are designed to provide many years of safe, trouble-free, dependable service when properly used and maintained.

To assist you in obtaining the best service from your crane and to avoid untimely crane and/or vehicle failure, this manual provides the following operating and service instructions. It is specifically recommended that all operating and service personnel consider this manual as mandatory material for reading and study before operating or servicing Auto Crane products. It is highly recommended that crane owners, equipment managers, and supervisors also read this manual.

Auto Crane has incorporated several safety features in the 4004EH crane for your protection.

For your convenience the overall dimensions of the 4004EH crane are included on the General Dimension Drawing. Rotation and turning radius are also listed on that drawing.

Remember, the crane adds weight to the vehicle. Adding weight may change the driving and riding characteristics of the vehicle unless the appropriate overload spring(s) are installed on the truck. The payload of the vehicle is reduced by the weight of the crane. The operator should exercise care when loading the vehicle. Distributing the payload on the vehicle evenly will greatly improve the driving and riding characteristics of the vehicle.

***Auto Crane Company issues a limited warranty certificate with each unit sold. See last page for warranty.***

The 4004EH cranes are attached directly to your 12 volt truck electrical system. The 4004EH is another highly efficient Auto Crane product. The use of a maintenance-free battery is not recommended on any Auto Crane product. The recommended alternator and battery that will give the longest life with the most useful duty cycle is a 75-amp

alternator with a 500 cold cranking amp battery. These specifications should be considered minimum.

It has always been Auto Crane Company policy to handle all warranty claims we receive as promptly as possible. If a warranty claim involves discrepant material or workmanship, Auto Crane will take immediate corrective action. It is understandable that Auto Crane Company cannot assume responsibility of liability when it is obvious that our products have been abused, misused, overloaded or otherwise damaged by inexperienced persons trying to operate the equipment without reading the manual.

***Auto Crane will not assume responsibility or liability for any modifications or changes made to unit, or installation of component parts without authorization.***

Auto Crane maintains a strong distributor network and a knowledgeable Customer Service Department. In most cases, an equipment problem is solved via phone conversation with our customer service department. The customer service department also has the ability to bring a local distributor, a regional sales manager, or a factory serviceman into the solution of an equipment problem.

If, through no fault of Auto Crane Company, it is necessary to send an experienced factory serviceman on a field service call the rates stated in the Auto Crane Distributor's Flat Rate Manual will apply.

Auto Crane Company's extensive Research and Development Program allow our customers to use the best equipment on the market. Our Engineering Staff and our knowledgeable sales people are always available to our customers in solving crane and winch-type application problems. When in doubt, call the Auto Crane factory.

***Note: This manual should remain with the crane at all times.***

# **4004EH**

## **INTRODUCTION**

### **DISTRIBUTOR ASSISTANCE:**

Should you require any assistance not given in this manual, we recommend that you consult your nearest Auto Crane Distributor. Our distributors sell authorized parts and have service departments that can solve almost any needed repair. This manual does not cover all maintenance, operating, or repair instructions pertinent to all possible situations. **If you require additional information, please contact the Auto Crane Company at the following telephone number: (918) 836-0463.** The information contained in the manual is in effect at the time of this printing. Auto Crane Company reserves the right to update this material without notice or obligation.

# 4004EH-20FT GENERAL SPECIFICATIONS

## DIMENSIONS

**Width:** 22 in (0.56 m)  
**Height:** 27 in (0.69 m)  
**Length:** 11 ft 11 in (3.63 m)  
 [Boom(s) stored]  
**Weight:** 925 lbs (420 kg)

## REACH

Second boom will reach from 10 feet 5 inches to 16 feet 5 inches.  
 Third boom will reach from 16 feet 5 inches to 20 feet 5 inches.

## CABLE

100 ft (20.3 m) of 5/16 in (7.93 mm) diameter aircraft quality cable.

## CAPACITY

16,000 ft-lbs (2.31 ton-m)  
 [ft-lbs = horizontal distance from centerline of rotation to free hanging weight (feet) x amount of weight (pounds)]

## CHASSIS REQUIREMENTS

10,500 lbs (4,763 kg) GVWR minimum

## ELECTRICAL SYSTEM REQUIREMENTS

**Voltage:** 12 VDC  
**Alternator:** 75 amp (minimum)  
**Battery:** 130 minute reserve capacity (minimum)  
 Maintenance type

<b>LIFTING CAPACITIES</b>			
ft	lbs	ft	lbs
3	4,000	12	1,333
4	4,000	13	1,231
5	3,200	14	1,143
6	2,667	15	1,067
7	2,286	16	1,000
8	2,000	17	941
9	1,778	18	889
10	1,600	19	842
11	1,455	20	800

## ROTATION

360° Continuous



# --- IMPORTANT ---

## SAFETY TIPS AND PRECAUTIONS

1. No unqualified or unauthorized person shall be allowed to operate the crane.
2. **WARNING:** Never weld, modify, or use unauthorized components / parts on any Auto Crane unit. This will void any warranty or liability. Also, failure of the crane may result.
3. Make certain the vehicle meets minimum chassis requirements. (These requirements do not guarantee unit stability.)
4. Make certain the crane is installed per factory specifications. Contact your local distributor or the Auto Crane factory if any questions arise.
5. Visual inspections and tests should be conducted at the beginning of each shift each day to insure that the crane and all its operating systems are in good condition and working order before it is used.
6. Inspect hydraulic hoses frequently for signs of deterioration, and replace them as required.
7. If a hydraulic break occurs, leave the area of the break and do not attempt to stop the break by hand as the hydraulic oil may be hot and under high pressure which can cause serious injury. Shut the system down as soon as possible.
8. Check the hook at least every thirty days for distortions or cracks and replace it as required.
9. Oil gears as required.
10. Stop all operations when cleaning, adjusting or lubricating the machine.
11. Keep dirt and grit out of moving parts by keeping crane clean. Make sure machine is free of excess oil, grease, mud and rubbish, thus reducing accidents and fire hazards.
12. When a new cable is installed, operate first with a light load to let the cable adjust itself.
13. Locate the vehicle at the work site for the best stability possible.
14. Keep the vehicle in a level position while loading or unloading.
15. Observe operating area for obstructions and/or power lines that might be a hazard.
16. **WARNING: NEVER OPERATE THE CRANE NEAR ELECTRICAL POWER LINES.** Auto Crane Company recommends that the crane never be any closer to a power line (including telephone lines) than 10 feet at any point.
17. Allow the vehicle engine to warm up before operating crane.
18. Know the weight of your rigging and load to avoid overloading the crane.
19. Deduct the weight of the load handling equipment from the load rating to determine how much weight can be lifted.
20. All load ratings are based on crane capacity, NOT the vehicle stability. Remember in lifting a heavy load, the weight can create enough tipping moment to overturn the vehicle
21. Always comply with load chart capacities, (centerline of rotation to hook).
22. Secure all loads before lifting.
23. Always set the emergency brake before beginning operation.
24. Keep objects and personnel clear of crane path during operation.
25. Operate control levers slowly and smoothly in order to meter oil flow for safe operation.
26. Always extend the outriggers from vehicle to the ground before crane operation. Insure that they are firmly positioned on solid footings. Stand clear of outriggers while they are being extended.
27. If any outrigger, when extended, rests on a curb or other object that prevents it from extending to its maximum distance, shorten bearing or fulcrum point and reduce the maximum load accordingly.
28. When an outrigger will not reach the ground due to holes or grades, it shall be blocked up to provide level and firm support for the truck.
29. When working in soft earth, use wide pads under outrigger feet to prevent sinking.
30. Always store outriggers before transportation.

## WARNING!

Auto Crane Company cranes are not designed or intended for use in lifting or moving persons. Any such use shall be considered to be improper and the seller shall not be responsible for any claims arising there from. This sale is made with the express understanding that there is no warranty that the goods shall be fit for the purpose of lifting or moving persons or other improper use and there is no implied warranty or responsibility for such purposes.

## **--- IMPORTANT ---**

# **SAFETY TIPS AND PRECAUTIONS**

31. Always store the crane in its stowed position for transportation.
32. Remember the overall height of the entire unit for garage door clearance or when moving under objects with low overhead clearance
33. Disengage power takeoff (PTO) before moving the vehicle.
34. Always walk around the vehicle before moving.
35. Never drive with a load suspended from crane.
36. Do not take your eyes off a moving load. Look in the direction you are moving.
37. Never swing a load over people.
38. Do not stop the load sharply in midair so that it swings like a pendulum. Meter the control levers to avoid this situation.
39. Crane boom length should be kept as short as possible for maximum lifting capacity and greater safety. Longer booms require additional care in accelerating and decelerating the swing motion, and thus slow down the working cycle and reduce productivity.
40. Keep the load directly and vertically under the boom point at all times. Crane booms are designed to handle vertical loads, not side lifts.  
**WARNING:** Never attempt to lift, drag, tow or pull a load from the side. The boom can fail far below its rated capacity.
41. Do not push down on anything with boom extensions; similarly do not lift anything with boom extensions.
42. Do not lift personnel with any wire rope attachment or hook. There is no implied warranty or responsibility for such purposes.
43. **WARNING:** In using a safety hook, ALWAYS close the hook throat before lifting a load. Proper attention and common sense applied to the use of the hook and various slings will prevent possible damage to material being hoisted and may prevent injury to personnel.
44. **WARNING:** Never place a chain link on the tip of the hook and try to lift a load with the hoist.
45. **WARNING:** Never use a sling bar or anything larger than the hook throat which could prevent the safety latch from closing, thus negating the safety feature.
46. Do not wrap the wire rope around sharp objects when using winch.
47. **WARNING:** Never unreel last 5 wraps of cable from drum.

# --- IMPORTANT --- OPERATING PRACTICES AND WARNINGS

1. Make certain the vehicle meets minimum chassis requirements. (These requirements do not guarantee unit stability)
2. Make certain the crane is installed per factory specifications. Contact your local Distributor or the Auto Crane factory if any questions arise.
3. Keep the vehicle in as level a position as possible while loading or unloading.
4. **ALWAYS** set the vehicle emergency brake before beginning crane operations.
5. **ALWAYS** use outriggers from vehicle to the ground during crane operation. Make sure they are firmly positioned on solid footings.
6. All load ratings are based on crane capacity, **NOT** truck/crane stability.
7. Keep objects and personnel clear of crane path during operation.
8. Keep hoist cable pulled tight at all times.
9. **REMEMBER**, in lifting a heavy load, the weight can create enough tipping momentum to overturn the vehicle.
10. **ALWAYS** keep load as close to ground as possible.
11. Hydraulic hoses need to be inspected frequently for signs of deterioration, and be replaced as required.
12. The hoist hook is an important item that an operator should consider and use properly. It should be checked on a daily basis for distortion or cracks.
13. **ALWAYS** store outriggers before road travel.
14. **WARNING! NEVER OPERATE THE CRANE NEAR ELECTRICAL POWER LINES!** Death or serious injury will result from boom, line, or load contacting electric lines. Do not use crane within 10 feet (3.05m) of electric power lines carrying up to 50,000 volts. One foot additional clearance is required for every additional 30,000 volts or less.
15. **WARNING! NEVER EXCEED** load chart capacities (centerline of rotation to hoist hook).
16. **WARNING! NEVER** un-reel last 5 wraps of cable from drum!
17. **WARNING! NEVER** wrap cable around load!
18. **WARNING! NEVER** attempt to lift or drag a load from the side! The boom can fail far below its rated capacity.
19. **WARNING! NEVER** weld, modify, or use unauthorized components on any Auto Crane unit! This will void any warranty or liability. Also failure of the crane may result.
20. **WARNING! NEVER** place a chain link on the tip of the hook and try to lift a load!
21. **WARNING! NEVER** use a sling bar or anything larger than the hook throat that could prevent the hook latch from closing, thus negating the safety feature!
22. **WARNING!** In using a hook with latch, **ALWAYS** insure that the hook throat is closed before lifting a load! Proper attention and common sense applied to the use of the hoist hook and various slings will prevent possible damage to material being hoisted and may prevent injury to personnel.  
**WARNING! NEVER** hold any Control Select Switch on that will cause unsafe operating conditions!

## WARNING!

**Auto Crane Company remote controlled, stiff boom cranes are not designed or intended for use on any applications involving the lifting or moving of personnel.**

# **QUALIFICATIONS FOR AND CONDUCT OF OPERATORS AND OPERATING PRACTICES**

## **REFERENCE ASME B30.5a AND OSHA 1910.180 FOR COMPLETE QUALIFICATION REQUIREMENTS**

### **OPERATORS**

1. Crane operation shall be limited to personnel with the following minimum qualifications:
  - A. Designated persons.
  - B. Trainees under the direct supervision of a designated person.
  - C. Maintenance and test personnel (when it is necessary in the performance of their duties).
  - D. Inspectors (crane).
2. No one other than the personnel specified above shall enter the operating area of a crane with the exception of persons such as oilers, supervisors, and those specified persons authorized by supervisors whose duties require them to do so and then only in the performance of their duties and with the knowledge of the operator or other persons.

### **QUALIFICATIONS FOR OPERATORS**

1. Operators shall be required by the employer to pass a practical operating examination. Qualifications shall be limited to the specific type of equipment for which examined.
2. Operators and operator trainees shall meet the following physical qualifications:
  - A. Vision of at least 20/30 Snellen in one eye and 20/50 in the other, with or without corrective lenses.
  - B. Ability to distinguish colors, regardless of position, if color differentiation is required for operation.
  - C. Adequate hearing with or without hearing aid for the specific operation.
3. Evidence of physical defects or emotional instability, which render a hazard to operator or others, which in the opinion of the examiner could interfere with the operator's performance, may be sufficient cause for disqualification. In such cases, specialized clinical or medical judgment and tests may be required.
4. Evidence that operator is subject to seizures or loss of physical control shall be sufficient reason for disqualification. Specialized medical

tests may be required to determine these conditions.

5. Operators and operator trainees should have normal depth perception, coordination, and no tendencies to dizziness or similar undesirable characteristics.
6. In addition to the above listed requirements, the operator shall:
  - A. Demonstrate the ability to comprehend and interpret all labels, operator's manuals, safety codes, and other information pertinent to correct crane operations.
  - B. Posses the knowledge of emergency procedures and implement it.
  - C. Demonstrate to the employer the ability to operate the specific type of equipment.
  - D. Be familiar with the applicable safety regulations.
  - E. Understand the operating procedures as outlined by the manufacturer.
  - F. Be thoroughly familiar with the crane and its control functions.
  - G. Understand the operating procedures as outlined by the manufacturer.

### **CONDUCT OF OPERATORS**

1. The operator shall not engage in any practice, which will divert his attention while actually operating the crane.
2. Each operator shall be responsible for those operations under the operator's direct control. Whenever there is any doubt as to safety, the operator shall consult with the supervisor before handling the loads.
3. The operator should not leave a suspended load unattended unless specific precautions have been instituted and are in place.
4. If there is a warning sign on the switch or engine starting controls, the operator shall not close the switch or start the engine until the warning sign has been removed by the appointed person.
5. Before closing the switch or starting the engine, the operator shall see that all controls are in the "OFF"

# **QUALIFICATIONS FOR AND CONDUCT OF OPERATORS AND OPERATING PRACTICES**

- or neutral position and all personnel are in the clear.
6. If power fails during operation, the operator shall:
    - A. Move power controls to the "OFF" or neutral position.
    - B. Land the suspended load and boom, if practical.
  7. The operator shall be familiar with the equipment and its proper care. If adjustments or repairs are necessary, the operator shall report the same promptly to the appointed person, and shall also notify the next operator.
  8. The operator at the start of each shift shall test all controls. If any controls do not operate properly, they shall be adjusted or repaired before operations are begun.
  9. Stabilizers shall be visible to the operator while extending or setting unless a signal person assists operator.
- C. Means are provided to hold the vehicle stationary while operating the crane.
  - D. Before starting to lift, the hook shall be positioned over the load in such a manner as to minimize swinging.
  - E. During lifting care shall be taken that:
    1. There is no sudden acceleration or deceleration of the moving load.
    2. Load, boom or other parts of the crane do not contact any obstruction.
  - F. Cranes shall not be used for dragging loads sideways.
  - G. This standard recognizes that telescopic boom cranes are designed and intended for handling materials. They do not meet personnel lift or elevator requirements. Therefore, no lifting, lowering, swinging or traveling shall be done while a person is on the hook or load. Hook attached suspended work platforms (baskets) shall not be used with cranes covered by this standard. Crane manufacturer must approve work platforms attached to the boom.
  - H. The operator should avoid carrying loads over people.
  - I. When the crane is so equipped, the stabilizers shall be fully extended and set. Blocking under stabilizers shall meet the requirements as follows:
    1. Strong enough to prevent crushing.
    2. Of such thickness, width and length as to completely support the stabilizer pad.
  - J. Firm footing under all tires, or individual stabilizer pads should be level. Where such a footing is not otherwise supplied, timbers, cribbing, or other structural members to distribute the load so as to not exceed allowable bearing capacity or the underlying material should provide it.
  - K. In transit, the boom shall be carried in stowed position.
  - L. When rotating the crane, sudden starts and stops shall be avoided. Rotational speed shall be such that the load does not swing out beyond the radius at which it can be controlled.
  - M. The crane shall not be transported with a load on the hook unless recommended by the manufacturer.

## **OPERATING PRACTICES/HANDLING THE LOAD**

1. Size of load.
  - A. No crane shall be loaded beyond the rated load except for test purposes.
  - B. The load to be lifted is to be within the rated load of the crane and its existing configuration.
  - C. When loads that are not accurately known are to be lifted, the person responsible for the job shall ascertain that the weight of the load does not exceed the crane rated load at the radius at which the load is to be lifted.
2. Attaching the load.
  - A. The load shall be attached to the hook by means of slings or other devices of sufficient capacity.
  - B. Hoist rope shall not be wrapped around the load.
3. Moving the load.

The operator shall determine that:

  - A. The crane is level and, where necessary, the vehicle/carrier is blocked properly.
  - B. The load is well secured and balanced in the sling or lifting device before it is lifted more than a few inches.

# QUALIFICATIONS FOR AND CONDUCT OF OPERATORS AND OPERATING PRACTICES

N. No person should be permitted to stand or pass under a suspended load.

4. Stowing procedure.

Follow the manufacturer's procedure and sequence when stowing and un-stowing the crane.

3. Caution shall be exercised when working near overhead lines, because they can move horizontally or vertically due to wind, moving the danger zone to new positions.

4. In transit with no load and boom lowered the clearance shall be specified in Table 1.

5. A qualified signalperson shall be assigned to observe the clearance and give warning before approaching the above limits.

## MISCELLANEOUS

### OPERATING NEAR ELECTRICAL POWER LINES

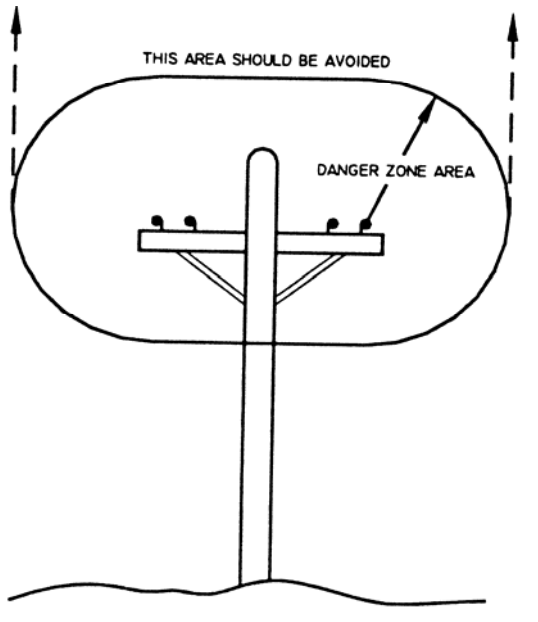

1. Cranes shall be operated so that no part of the crane or load enters into the danger zone shown above.

#### EXCEPTIONS

A. The danger zone may be entered after confirmation by an appointed person that the electrical distribution and transmission lines have been de-energized and visibly grounded at the point of work; or

B. The danger zone may be entered if insulating barriers (not a part of nor an attachment to the crane) have been erected to prevent physical contact with the lines.

2. For lines rated 50 kV or below, minimum clearance between the lines and any part of the crane or load (including handling appendages) shall be 10-ft. (3m). For higher voltages, see Table 1.

A. Any overhead wire shall be considered to be an energized line unless and until the person owning such line or the electrical utility authorities verify that it is not an energized line.

B. Exceptions to this procedure are allowed, if approved by the administrative or regulatory authority provided the alternate procedure insures equivalent protection and is set forth in writing.

C. Durable signs shall be installed at the operator's station and on the outside of the crane, warning that electrocution or serious bodily injury may occur unless a minimum clearance of 10 ft. (3.0m) between the crane or the load being handled and energized power lines. Greater clearances are required because of higher voltage as stated above. These signs shall be revised but not removed when local jurisdiction requires greater clearances.

**TABLE 1**

normal voltage, kV (phase to phase)		minimum required clearance	
		ft	(m)
<u>when operating near high voltage power lines</u>			
over	to 50	10	(3.50)
over	50 to 200	15	(4.6)
over	200 to 350	20	(6.1)
over	350 to 500	25	(7.62)
over	500 to 750	35	(10.67)
over	750 to 1000	45	(13.72)
<u>while in transit with no load and boom lowered</u>			
over	to 0.75	4	(1.22)
over	0.75 to 50	6	(1.83)
over	50 to 345	10	(3.83)
over	345 to 750	16	(4.87)
over	750 to 1000	20	(6.1)

## **--- IMPORTANT --- OPERATION OF UNIT**

1. Make sure this manual has been thoroughly read by all crane operating personnel and supervisors.
2. A routine inspection of the crane should be mandatory before each operating day. Any defects should be corrected immediately.
3. At a job site the vehicle should be positioned so that the crane can adequately reach the load within the rated capacity (centerline of rotation to hoist hook).
4. Keep the vehicle as level as possible during operation.
5. For electric cranes, **engage emergency brake** and leave ignition on with transmission in neutral (or in park for automatic transmissions). Activate any crane power switches. For Auto Crane units requiring battery and hydraulic operation, **engage emergency brake**, place gear selector in neutral, press clutch, activate PTO, release clutch and after hydraulic fluid is warm, set throttle control to proper engine speed.
6. Always use outriggers from the truck to the ground. Be sure these are firm and adequately positioned. When rotating, **keep load as low to the ground as possible**.
7. Remove the transmitter from cab or storage area. Power transmitter on. Detach hook from dead man. Crane is now ready for operation.
8. Always boom up before rotating so the boom will clear the required boom support.
9. When extending the boom, always maintain clearance between the boom crown and the traveling block or hoist hook.
10. Always observe safe and practical operation to avoid possible accidents. Refer to Safety Tips and Precautions.
11. After completing lifting operations, return the boom to stowed position on the boom support. Avoid unneeded pressure on the boom support.
12. Store transmitter in proper location (in cab or storage area).
13. Return outriggers to stowed position. Make sure they are pinned in place or jacklegs are returned to compartment.
14. Check work area for any tools or equipment not stored.
15. Release throttle control, depress clutch and disengage PTO. Deactivate any crane power switches.
16. Report any unusual occurrence during crane operation that may indicate required maintenance or repair.
17. **NEVER** use two cranes to support a load too large for either crane.

## **OPERATION OF OUTRIGGERS**

### **HYDRAULIC OUTRIGGERS**

1. Shift crane/outrigger control valve to "outrigger" position.
2. Operate the outrigger control valves to position the outriggers.
3. After outriggers are positioned, return crane/outrigger selector to "crane" position.
4. Crane is now ready to operate.

### **MANUAL OUTRIGGERS**

1. Pull lock pins to release jackleg or drop down outrigger and move to outermost lock position.
2. Make sure lock pins are reinstalled properly.
3. Lower outrigger pad to firm ground and adjust foot to take out slack.
4. Crane is now ready to operate.

# INSPECTION REQUIREMENTS

## REFERENCE ASME B30.5a AND OSHA 1910.180 FOR COMPLETE INSPECTION REQUIREMENTS

### INSPECTION CLASSIFICATION

#### 1. Initial inspection.

Prior to initial use, all new, altered, modified or extensively repaired cranes shall be inspected by a designated person to insure compliance with provisions of this standard.

#### 2. Regular inspection.

Inspection procedure for cranes in regular service is divided into two general classifications based upon the intervals at which inspection should be performed. The intervals in turn are dependent upon the nature of the components of the crane and the degree of their exposure to wear, deterioration, or malfunction. The two general classifications are herein designated as "frequent" and "periodic" with respective intervals between inspections as defined below.

- A. Frequent inspection - daily or before each use
- B. Periodic inspection - one to twelve-month intervals or as specifically recommended by the manufacturer or qualified person.

**DESIGNATED PERSONNEL SHALL  
PERFORM INSPECTIONS ONLY.**

### FREQUENT INSPECTION

Inspections should also occur during operation for any deficiencies that might appear between regular inspections. Any deficiencies, such as those listed below, shall be carefully examined and a determination made as to whether they constitute a hazard:

1. Inspect control mechanisms for maladjustment that interferes with proper operation.
2. Inspect control mechanisms for excessive wear of components and contamination by lubricants or other foreign matter.

3. Inspect safety devices for malfunction.
4. Visually inspect all hydraulic hoses, particularly those that flex in normal operation of crane functions.
5. Inspect hooks and latches for deformation, chemical damage, cracks, and wear. Refer to ANSI/ASME B30.10.
6. Inspect for proper rope reeving.
7. Inspect electrical wiring and components for malfunctioning, signs of excessive deterioration, dirt and moisture accumulation.
8. Inspect hydraulic system for proper oil level and leaks.
9. Inspect tires for recommended inflation pressure, cuts and loose wheel nuts.
10. Inspect connecting pins and locking device for wear damage and loose retaining bolts.
11. Inspect rope for gross damage, such as listed below, which may be an immediate hazard.
  - A. Distortion such as kinking, crushing, unstranding, birdcaging, main strand displacement, or core protrusion. Loss of rope diameter in a short length or unevenness of outer strands should be replaced.
  - B. General corrosion.
  - C. Broken or cut strands.
  - D. Use care when inspecting sections of rapid deterioration around flange points, crossover points, and repetitive pickup points on drums.
  - E. Inspect number, distribution, and type of visible broken wires. Reference Rope Maintenance section in the owner's manual.

***Continued use of rope depends upon good judgment by a designated person in evaluating remaining strength in a used rope after allowance for deterioration disclosed by inspection. Continued rope operation depends upon this remaining strength.***



# INSPECTION REQUIREMENTS

## PERIODIC INSPECTION

Any deficiencies, such as those listed below, shall be carefully examined and determination made as to whether they constitute a hazard:

1. Inspect for deformed, cracked or corroded members in the crane structure and entire boom.
2. Inspect for loose bolts, particularly mounting bolts.
3. Inspect for cracked or worn sheaves and drums.
4. Inspect for worn, cracked, or distorted parts such as pins, bearings, shafts, gears, rollers and devices.
5. Inspect for excessive wear on brake and clutch system parts and lining.
6. Inspect crane hooks for cracks.
7. Inspect travel steering, braking, and locking devices for malfunction.
8. Inspect for excessively worn or damaged tires.
9. Inspect hydraulic hose, fittings, and tubing for the following problems:
  - A. Evidence of leakage at the surface of the flexible hose or its junction with metal and coupling.
  - B. Blistering, or abnormal deformation to the outer covering of the hydraulic or pneumatic hose.
  - C. Leakage at threaded or clamped joints that cannot be eliminated by normal tightening or recommended procedures.
  - D. Evidence of excessive abrasion or scrubbing on the outer surface of a hose, rigid tube, or fitting. Means shall be taken to eliminate the interference of elements in contact or otherwise protect the components.
10. Inspect hydraulic pumps and motors for the following problems:
  - A. Loose bolts and fasteners.
  - B. Leaks at joints between sections.
  - C. Shaft seal leaks.
  - D. Unusual noises or vibrations.
  - E. Loss of operating speed.
  - F. Excessive heating of the fluid.
  - G. Loss of pressure.
11. Inspect hydraulic valves for the following problems:
  - A. Cracks in valve housing.
  - B. Improper return of spool to neutral position.
  - C. Leaks at spools or joints.
  - D. Sticking spools.
  - E. Failure of relief valves to attain or maintain correct pressure setting.
  - F. Relief valve pressure shall be checked as specified by the manufacturers.
12. Inspect hydraulic cylinders for the following problems:
  - A. Drifting caused by fluid leaking across piston.
  - B. Rod seals leaking.
  - C. Leaks at welding joints.
  - D. Scored, nicked, or dented cylinder rods.
  - E. Damaged case (barrel).
  - F. Loose or deformed rod eyes or connecting joints.
13. Inspect hydraulic filters for evidence of rubber particles on the filter elements indicating possible hose, "O" ring, or other rubber component deterioration. Metal chips or pieces on the filter may denote failure in pumps, motors, or cylinders. Further inspection will be necessary to determine the origin of the problem before corrective action can be taken.
14. Inspect labels to confirm correct location and legibility. Reference decal layout in this manual for proper location of decals.
15. **Rope Inspections need not be at equal calendar intervals and should be more frequent as the rope approaches the end of useful life.** A qualified person shall inspect the wire rope based on such factors as:
  - A. Expected rope life as determined by experience on the particular installation or similar installations.
  - B. Severity of environment.
  - C. Percentage of capacity lifts.
  - D. Frequency rates of operation.
  - E. Exposure to shock loads.This inspection shall cover the entire length of the rope. Only the surface wires need to be inspected and no attempt should be made to open the rope. Any deterioration resulting in appreciable loss of original strength shall be noted and determination made as to whether use of the rope would constitute a hazard. A few notable deterioration points are listed below:

# **INSPECTION REQUIREMENTS**

- A. Reduction of rope diameter below nominal diameter due to loss of core support.
- B. Internal or external corrosion.
- C. Wear of outside wires.
- D. Severely corroded, cracked, bent, worn, or improperly applied connections.

## **CRANES NOT IN REGULAR USE**

A crane, which has been idle for a period of over one month or more, shall be given an inspection conforming to the "initial" and "regular" inspection requirements of this section.

## **INSPECTION RECORDS**

Dated records of periodic inspection should be made on critical items such as brakes, crane hooks, rope, cylinders, and relief pressure valves.

# ***TESTING REQUIREMENTS***

**REFERENCE ASME B30.5a AND OSHA 1910.180 FOR COMPLETE TESTING REQUIREMENTS**

**TESTING SHALL BE PERFORMED BY DESIGNATED PERSONNEL ONLY.**

Prior to initial use, all new, altered, modified, or extensively repaired cranes shall be tested for compliance with the operational requirements of this crane.

Test requirements:

1. Test all functions to verify speed and operation.
2. Check that all safety devices are working properly.
3. Confirm operating controls comply with appropriate function labels.
4. Test loads shall not exceed 110% of the manufacturer's load rating.
5. Written reports shall be maintained showing test procedures and confirming the adequacy of repairs.

# **GENERAL REPAIRS AND MAINTENANCE**

## **REFERENCE ASME B30.5a AND OSHA 1910.180 FOR COMPLETE MAINTENANCE AND REPAIR REQUIREMENTS**

A preventative maintenance program should be established based on this section and all replacement parts should be obtained from AutoCrane Company.

**For replacement parts contact your local authorized distributor.**

### **MAINTENANCE PRECAUTIONS**

1. Place crane where it will cause the least interference with other equipment or operations.
2. Verify all controls are in the "off" position and all operating features secured from inadvertent motion by brakes, pawls, or other means.
3. The means for starting the crane shall be rendered inoperative.
4. The boom should be secured in place before maintenance.
5. Relieve hydraulic oil pressure from all hydraulic circuits before loosening or removing hydraulic components.
6. Warning or "OUT OF ORDER" signs shall be placed on all crane controls.
7. After adjustments and repairs have been made, the crane shall not be returned to service until all guards have been reinstalled, trapped air removed from hydraulic system (if required), safety devices reactivated, and maintenance equipment removed.

### **ADJUSTMENTS AND REPAIRS**

1. Any hazardous conditions disclosed by the inspection requirements shall be corrected before operation of crane is resumed. Only designated personnel shall do adjustments and repairs.
2. Adjustments shall be maintained to assure correct functioning of components, the following are examples:
  - A. Functional operating mechanism.
  - B. Safety devices.
  - C. Control systems.
3. Repairs or replacements shall be provided as needed for operation, the following are examples:
  - A. Critical parts of functional operating mechanisms which are cracked, broken, corroded, bent, or excessively worn.

- B. Critical parts of the crane structure which are cracked, bent, broken, or excessively corroded.
  - C. Crane hooks showing cracks, damage, or corrosion shall be taken out of service. Repairs by welding are not recommended.
4. If bleeding the hydraulic system is required, run each crane function until smooth operation of that particular function is noticeable.

### **LUBRICATION**

All moving parts of the crane, for which lubrication is specified, should be regularly lubricated per the manufacturer's recommendations and procedures. **Reference Lubrication and Maintenance Schedule in this manual.**

### **ROPE REPLACEMENT**

**No precise rules can be given for determination of the exact time for replacement of rope, since many variable factors are involved.**

1. Conditions such as the following shall be reason for questioning continued use of the rope or increasing the frequency of inspection:
  - A. In running ropes, six randomly distributed broken wires in one lay or three broken wires in one strand in one lay.
  - B. One outer wire broken at the contact point with the core of the rope structure and protrudes or loops out of the rope structure. Additional inspection of this section is required.
  - C. Wear of one third of the original diameter of the outside individual wire.
  - D. Kinking, crushing, bird caging, or any other damage resulting in distortion of the rope structure.
  - E. Evidence of any heat damage from any cause.
  - F. Reduction from nominal diameter of more than 1/64 in. (0.4mm) for diameters up to and including 5/16 in. (8 mm), 1/32 in. (0.8 mm) for diameter 3/8 in. (9.5 mm) to and including 1/2 in. (13 mm), 3/64 in. (1.2 mm) for diameter 9/16 in. (14.5 mm) to and including 3/4 in. (19 mm), 1/16 in. (1.6 mm) for diameter 7/8 in. (22 mm) to and including 1 1/8 in. (29 mm), 3/32 in.

# **GENERAL REPAIRS AND MAINTENANCE**

(2.4 mm) for diameters 1 1/4 in. (32 mm) to and including 1 1/2 in. (38 mm).

- G. In standing ropes, more than two broken wires in one lay in sections beyond end connections or more than one broken wire at an end connection.
2. Replacement rope shall have a strength rating at least as great as the original rope furnished or recommended by AutoCrane. A rope manufacturer, AutoCrane, or a qualified person shall specify any deviation from the original size, grade, or construction.

## **ROPE MAINTENANCE**

1. Rope should be stored to prevent damage or deterioration.
2. Unreeling or uncoiling of rope shall be done as recommended by the rope manufacturer and with care to avoid kinking or inducing twist.
3. Before cutting a rope, seizing shall be placed on each side of the place where the rope is to be cut to prevent unlaying of the strands. On pre-formed rope, one seizing on each side of the cut is required. On non-preformed ropes of 7/8 in. (22 mm) diameter or smaller, two seizings on each side of the cut are required, and for non-preformed rope 1 in. (25 mm) diameter or larger, three seizings on each side of the cut are required.
4. During installation care should be exercised to avoid dragging of the rope in the dirt or around objects that will scrape, nick crush or induce sharp bends in it.
5. Rope should be maintained in a well-lubricated condition. It is important that lubricant applied as a part of a maintenance program shall be compatible with the original lubricant and to this end the rope manufacturer should be consulted. Lubricant applied shall be the type that does not hinder visual inspection. Those sections of rope that are located over sheaves or otherwise hidden during inspection and maintenance procedures require special attention when lubricating rope. The object of rope lubrication is to reduce internal friction and to prevent corrosion.
6. When an operating rope shows greater wear or well-defined localized areas than on the remainder of the rope, rope life can be extended in some cases by shifting the wear to different areas of the rope.

# MAINTENANCE OF BATTERIES

Maintenance of Auto Crane unit batteries differs very little from the generally prescribed maintenance of any lead acid battery. All batteries must be kept properly charged, properly filled with water, and relatively clean.

## Keep Properly Charged

Many things affect the proper charge to a battery, such as:

1. Regulator settings.
2. Proper tightness of belts on the alternator or generator.
3. Good, clean connections of all cables and wires at the following places:
  - a. Battery.
  - b. Regulator.
  - c. Starting motor.
  - d. Alternator or generator.
  - e. Ground connections (most important).

It is of extreme importance to keep the battery as fully charged as possible without overcharging, especially when vehicles are left outside for extended periods in extremely cold climates. A battery can freeze. Freezing points for various specific gravities of acid are as follows:

Specific Gravity (Corrected to 80°F)	Freezing Temp. Degrees F.
1.280	-90°F
1.250	-62°F
1.200	-16°F
1.150	5°F
1.100	19°F

As shown, a half-charged battery (about 1.100 specific gravity) cannot stand for any length of time at 20°F or it will freeze.

The main reason for keeping the battery as fully charged as possible without over-charging is to insure that power is available even though the vehicle has been standing for some time.

## Keep Properly Filled with Water

The battery should *always* be properly filled with water. If the electrolyte level is allowed to fall below the top of the plates, the results become threefold:

1. The exposed portion of the plate will become sulfated.
2. The portion of the plate exposed is not usable.
3. That portion of the acid remaining becomes more concentrated and may cause more rapid

deterioration of the remaining parts of the battery.

## Keep A Relatively Clean Battery

The battery should be kept clean. Batteries filled with acid and which are not in use self-discharge to a limited degree because of the nature of the materials within the battery. If dirt is allowed to collect on the top of the battery (and this dirt absorbs moisture) and electrical path can be set up between the various terminals of the battery and the ground. Once such a path has been established, the self-discharge of the battery is accelerated. This also accelerates corrosion of the battery cables at the terminals.

## Periodic Maintenance is Needed

A definite program of periodic maintenance of all batteries should be conducted on a regular basis. Periodic maintenance includes:

1. Checking belts for tightness on the charging equipment.
2. Checking battery electrolyte levels.
3. Checking cables for good connections.
4. Cleaning where corrosion is apparent.

When corrosion is cleaned off, the cable terminals and battery terminals should be coated with a light coating of petroleum jelly before they are replaced. When terminals are cleaned, the top of the battery should be cleaned with a mild solution of soda water.

## Low Maintenance Batteries (Maintenance Free)

**Low maintenance batteries should not be used on AutoCrane Cranes or trucks equipped with AutoCrane Cranes. The batteries are not designed for "deep" discharge.**

## Testing Your Battery

If the condition of the battery is in question, it should be removed from the vehicle, taken to the shop, and allowed to reach room temperature. It should then be recharged until specific gravity readings taken at one-half hour intervals. If the specific gravity readings are fairly uniform, the battery should be checked with a high rate tester. Use the tester in accordance with the manufacturer's instructions. The high rate tester is the best method to test a questionable battery.

# ***MAINTENANCE OF BATTERIES***

If, after charging, it is noted that the specific gravity reading of one cell is 30 points less than any of the other cells, it may be assumed that the cell is bad and that the battery should be replaced. If all cells are uniform but not up to full charge, a low rate of charge should be attempted for an extended time. This usually will recover a badly sulfated battery.

## **Replacing a Battery**

If it is necessary to replace a battery, and a dry charge battery is used, the following procedure applies:

1. Fill the battery with electrolyte of the proper specific gravity.

2. Place the battery on charge according to the manufacturer's instructions.

It is essential that the second step above be followed to ensure that the battery going on the vehicle is fully charged.

It is also very important that the battery hold-downs be checked periodically to insure that the batteries are properly positioned to avoid vibration problems, breakage of cables or terminals. Care must be taken to avoid cracking or breaking containers or covers by tightening hold-down fixtures excessively. They also must not be so loose that breakage results from a hold-down that is too loose.

# 4004EH

## LUBRICATION & MAINTENANCE SCHEDULE

SERVICE PERFORMED	DAY	WKLY	3 MOS	6 MOS	YEAR	NOTES
LOAD HOOK	X					INSPECT HOOK & LATCH FOR DEFORMATION, CRACKS, & CORROSION
CABLE DRUM	X					MAKE SURE CABLE IS WOUND EVENLY ON DRUM
HOIST / BOOM CABLE	X					CHECK FOR FLATTENING, KINKS, & BROKEN STRANDS, SEE MANUAL
HYD. HOSES	X					VISUAL INSPECTION
HYD. FLUID	X					CHECK FLUID LEVEL
MOTOR CONNECTIONS		X				CHECK TERMINALS FOR TIGHT CONNECTIONS
POWER CABLE			X			CHECK INSULATION FOR DAMAGE OR DETERIORATION
PIN RETAINING BOLTS	X					CHECK TORQUE TO 23 FT-LBS (GRADE 5), 35 FT-LBS (GRADE 8) AS REQUIRED
MOUNTING BOLTS		X				CHECK TORQUE: TO 335 FT-LBS FOR 3/4-16
ROTATION RING GEAR		X				LUBE WITH MOBILETAC LL, OR LUBRIPLATE P/N 15263, OR EQUAL
SHEAVE BEARINGS		X				SEALED BEARING, REPLACE IF ROUGH OR LOOSE
ALL OTHER BOLTS		X				CHECK TIGHTEN AS REQUIRED
LIFT CYLINDER BEARINGS			X			GREASE WITH MOBILEPLEX EP-2 OR EQUIVALENT @ ZERKS
ROTATION BEARING			X			GREASE WITH MOBILEPLEX EP-2 OR EQUIVALENT @ ZERKS
ROTATION BEARING BOLTS			X			CHECK TORQUE TO 170 FT-LBS (HEX HEAD)
HOIST GEARBOX				X		WORM GEAR-EP GEAR LUBE SAE 80-90; SPUR GEARS-SAE 30 OIL
ROTATION WORM BEARING				X		GREASE WITH MOBILEPLEX EP-2 OR EQUIVALENT @ ZERKS
HYDRAULIC FLUID					X	DRAIN, FLUSH, AND REFILL WITH MOBILE DTE 13 HYD. OIL
BOOM SLIDE PADS	PADS GREASED WHEN REPLACED					
FOR ADDITIONAL INFORMATION SEE:	1) OWNER'S MANUAL 2) OSHA SECTION 1910.180 3) ANSI B30.5-1989					

**CAUTION:** Routine maintenance insures trouble-free operation and protects your investment. All warranties are void if maintenance is neglected.



# **4004EH**

## **LUBRICATION & MAINTENANCE SCHEDULE**

### **NOTES:**

1. Use only authorized parts. Any damage or malfunction caused by the use of unauthorized parts is not covered by Warranty or Product Liability.
2. Once a bolt has been torqued to its rated capacity and then removed; the bolt should be replaced with a new one.
3. Auto Crane Company recommends that this crane be serviced per "Crane Inspection Log" P/N 999978. These logs should be filled in at the intervals noted and kept as a permanent record. Additional copies are available from your local distributor.

# 4004EH WINCH BRAKE ADJUSTMENT

## ADJUSTING OIL COOLED WORM BRAKE

The oil-cooled, fully adjustable, automatic safety brake operates in the worm housing lubricant, all part being submerged in oil. When the brake wears to the point that the load begins to drift, the brake can be adjusted as follows:

1. Loosen the lock nut on the adjusting screw.
2. Tighten the brake by turning the adjusting screw clockwise.  
**CAUTION:** Only  $\frac{1}{4}$  turn is usually required to adjust the brake. Over-tightening can cause overheating, and damage to the brake parts. Tighten the lock nut after adjustment is completed.

If the brake does not respond to adjustment then a new leaf spring and brake disc is needed.

A torque wrench can be equipped with a special adapter to fit the input shaft (worm) of the winch. The adapter can be made by welding a nut to the end of a piece of tubing as shown in the following figure.

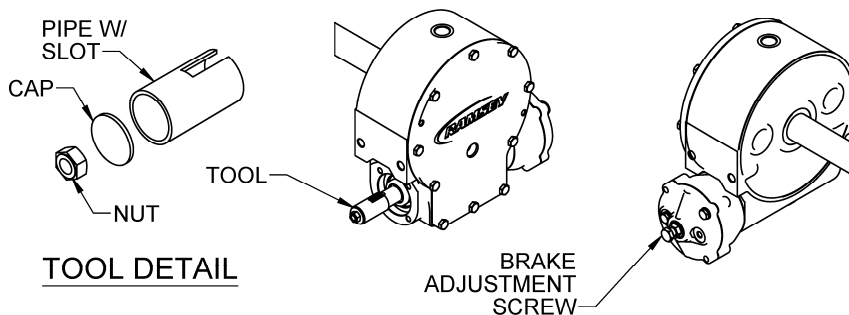

After welding the cap and nut to the tubing, slot the tubing as shown. This will allow the special adapter to slide over the keyway and then act as a large socket. A torque wrench can then be used to apply the proper torque. Turn the torque wrench so that the drum turns in the spool out direction or lowering direction. The torque ratings should be between 15-18 ft-lbs.

If the torque wrench does not show the proper value as it turns, then the worm brake adjusting bolt should be turned clockwise  $\frac{1}{4}$  turn. Each time the adjusting bolt is turned, check the torque reading. Continue this procedure until the proper torque reading is achieved. Then tighten the lock nut.

# ***NOTES***

# 4004EH

## SAFETY DECAL SECTION

PART NO.: 040529000  
 DECAL: ELECTROCUTION HAZARD  
 FUNCTION: To inform the operator of the hazard involved with contacting electrical power lines with crane boom.  
 USED ON: All Cranes.  
 QUANTITY: 2  
 PLACEMENT: Both sides of end of lower boom.

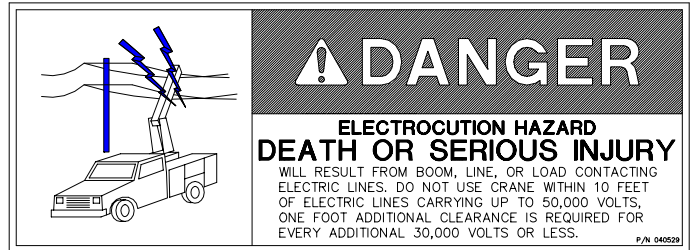

PART NO.: 040517000  
 DECAL: STAY CLEAR OF BOOM  
 FUNCTION: To inform the operator of the hazard of proximity or contact with the crane boom during operation.  
 USED ON: All Cranes.  
 QUANTITY: 2  
 PLACEMENT: Both sides of crown.

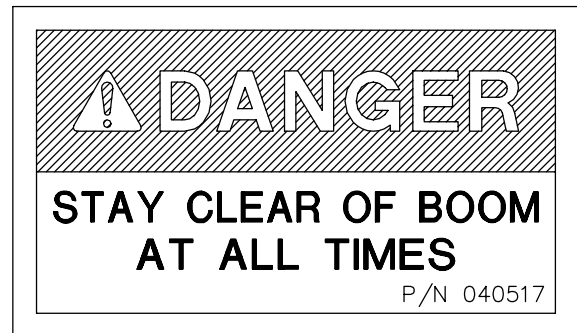

PART NO.: 040518000  
 DECAL: STAY CLEAR OF LOAD  
 FUNCTION: To inform the operator of the hazard of proximity or contact with the crane load during operation.  
 USED ON: All Cranes.  
 QUANTITY: 2  
 PLACEMENT: Both sides of traveling block.



# 4004EH

## SAFETY DECAL SECTION

PART NO.: 040587000      USED ON: All cranes equipped with a load sensor.

DECAL: LOAD SENSOR, DON'T TAMPER      QUANTITY: 2

FUNCTION: To inform the operator that the load sensor is pre-set and that tampering with the sensor may cause potentially hazardous situation.      PLACEMENT: Both sides of the lift cylinder near the load sensor.

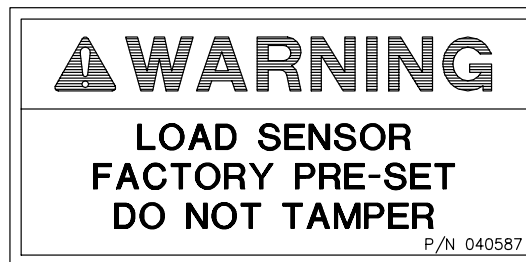

PART NO.: 040519000      USED ON: All cranes.

DECAL: SCISSORS POINT      QUANTITY: 2

FUNCTION: To inform the operator of possible danger at scissors point on crane.      PLACEMENT: Both sides of the lift cylinder.

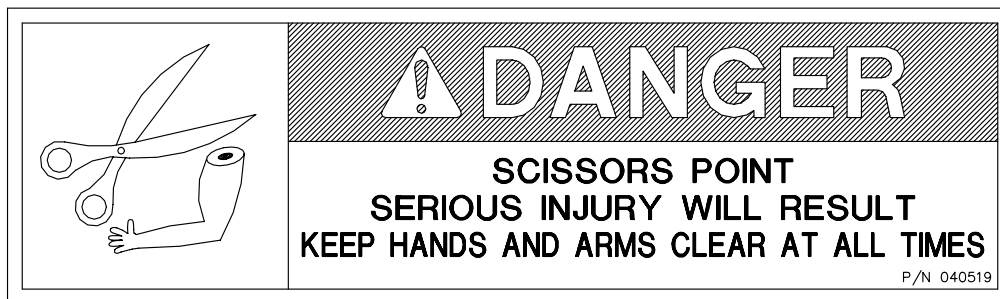

# ***NOTES***

# 4004EH

## SAFETY DECAL SECTION

PART NO.: 460169000      USED ON: All Cranes equipped with FM controls.

DECAL: REMOTE CONTROL      QUANTITY: 1

FUNCTION: To inform the operator of failure to follow the safety precautions may result in equipment failure or serious personal injury.      PLACEMENT: FRONT OF POWER UNIT



## WARNING

### REMOTE CONTROL SAFETY PRECAUTIONS

READ THE OPERATOR'S MANUAL before using the Remote Control System. Failure to follow the safety precautions may result in equipment failure or serious personal injury.

MAKE SURE MACHINERY AND SURROUNDING AREA IS CLEAR BEFORE OPERATING REMOTE CONTROL SYSTEM. Do not activate the Remote Control System unless it is safe to do so.

TURN OFF THE RECEIVER POWER BEFORE WORKING ON THE MACHINE. Always disconnect the Remote Control System before doing any maintenance to prevent accidental operation of the machine.

DO NOT MODIFY EQUIPMENT WITHOUT WRITTEN APPROVAL FROM THE MANUFACTURER.

### CARE

KEEP DRY. Do not clean the Transmitter / Receiver under high pressure. If water or other liquids get inside the Transmitter battery or Receiver compartment, immediately dry the unit. Remove the case and let the unit air dry.

Clean the unit after operation using a damp cloth to remove any mud, dirt, concrete, etc. from the unit and prevent clogging of buttons, switches, etc.

### MAINTENANCE / WELDING

DISCONNECT THE RECEIVER BEFORE WELDING ON THIS MACHINE. Failure to disconnect will result in the destruction of the Receiver.

460169000 A

# 4004EH-20FT DECAL LAYOUT

P/N: 404240009

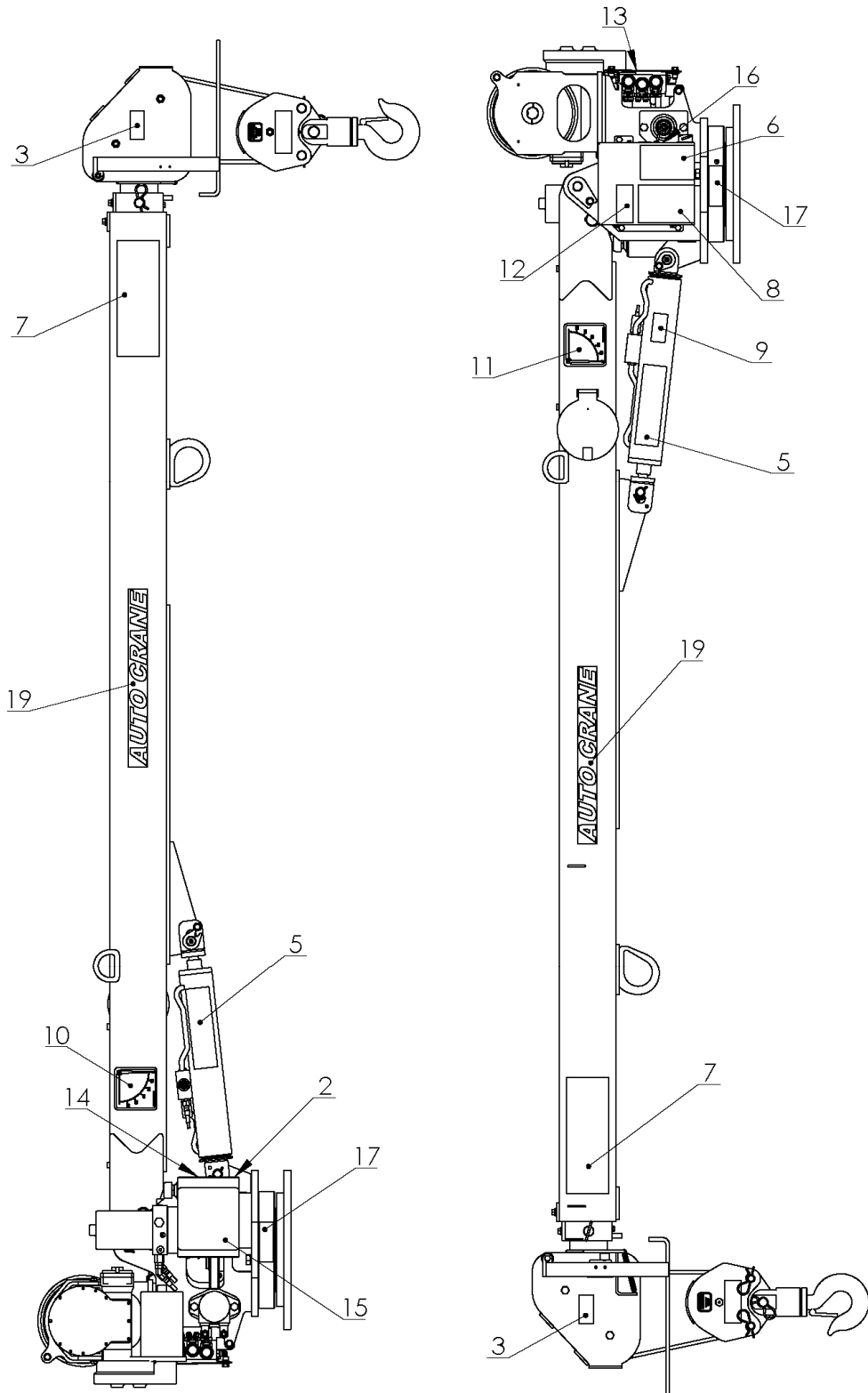



# 4004EH-20FT DECAL LAYOUT

## P/N: 40424009

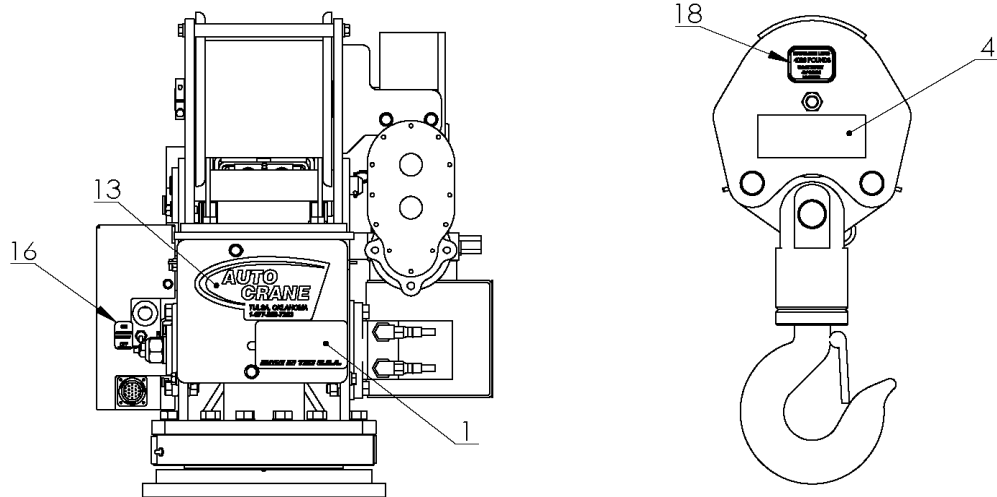

ITEM NO.	QTY.	PART NO.	DESCRIPTION
1	1	040824000	DECAL, AMERICAN FLAG, MADE IN THE U.S.A.
2	1	040632000	DECAL WARNING - OVERLOAD
3	2	040517000	DECAL STAY CLEAR OF BOOM
4	2	040518000	DECAL STAY CLEAR OF LOAD
5	2	040519000	DECAL DANGER SCISSOR POINT
6	1	040579000	DECAL OPERATION INSTRUCTIONS
7	2	040529000	DECAL DANGER "ELECTROCUTION HAZARD" POWER LINE
8	1	040580000	DECAL TRAINED OPERATOR
9	1	040587000	DECAL WARNING LOAD SENSOR
10	1	320318000	DECAL ANGLE INDICATOR CS
11	1	320318001	DECAL ANGLE INDICATOR SS
12	1	330622000	DECAL SERIAL NO
13	1	360034000	DECAL AUTO CRANE LOGO
14	1	460169000	DECAL WARNING, REMOTE CONTROL
15	1	404240011	LOAD CHART, 4004 EH 20FT BOOM
16	1	404225000	DECAL, RECEIVER/PENDANT
17	2	404208000	DECAL 4004EH, HORIZONTAL
18	2	404212000	DECAL MAX BLOCK LOAD 4004
19	2	600047000	DECAL AUTO CRANE

# 4004EH-20FT GENERAL DIMENSIONS

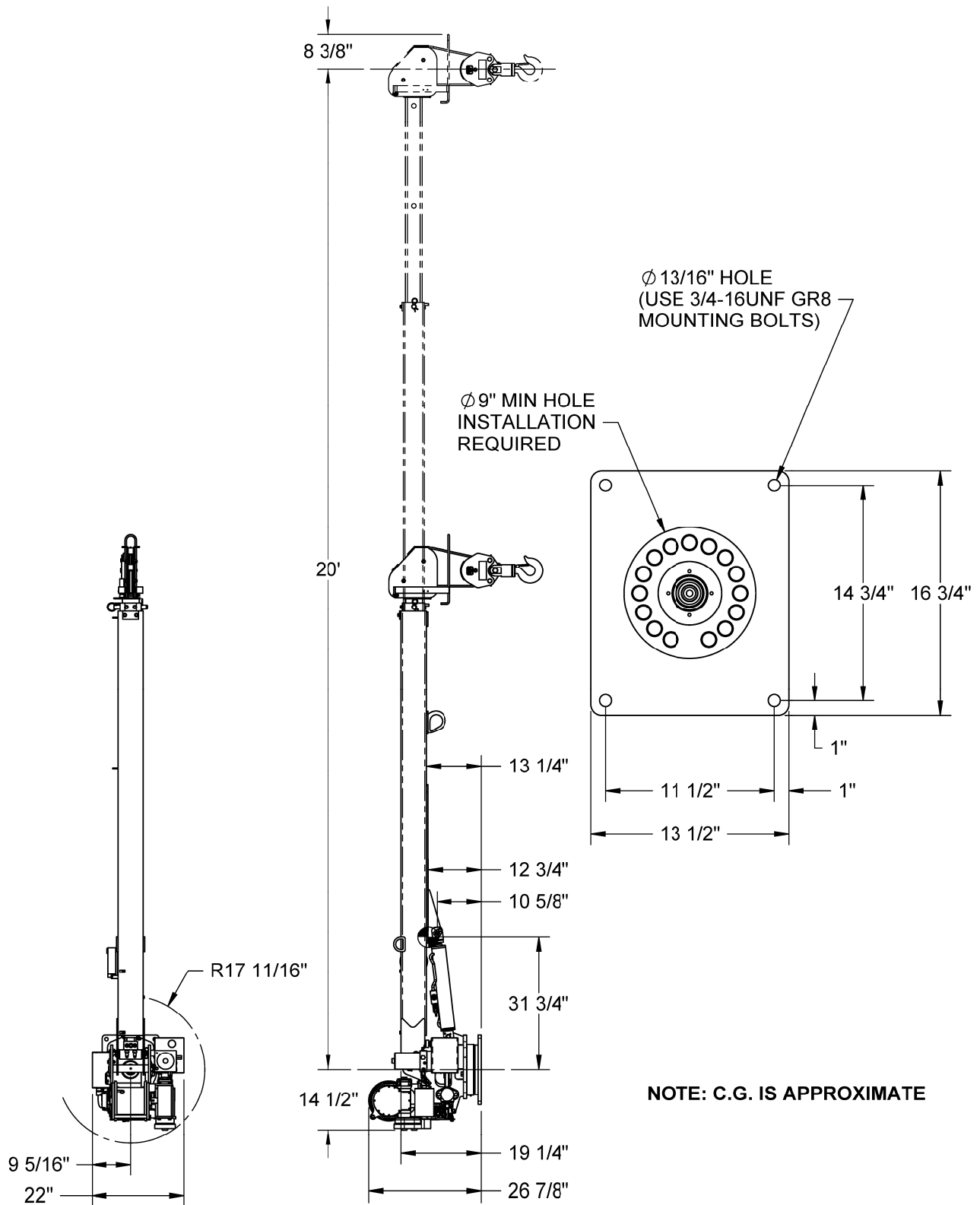

# 4004EH

## MOUNTING AND INSTALLATION

1. Check to make sure the following items are with your crane.

ITEM	QTY	PART NO.	DESCRIPTION
1	4	404226000	SCREW, HX. HD, 3/4-16NF X 3" LG. GRADE 8
2	4	022101000	WASHER, SP. LK. 3/4
3	4	404227000	NUT, HEX 3/4-16UNF
4	6	083800000	CLIP, CABLE #838 (FRAME)
5	1	404240015	OWNER'S MANUAL (4004EH)
6	4	022102000	WASHER FL 3/4
7	1	404211000	TRAVELING BLOCK
8	1	404218000	TWECO CABLE ASSY W/ MASTER SWITCH
9	1	404223000	CABLE PWR, 25 ft
10	1	320806000	CABLE ASSY #10 x 48 LG

2. Vehicle should meet minimum GVW rating of 10,500 pounds. (does not include bodies or accessories)
3. Make sure mounting surface is properly reinforced to withstand 16,000 ft-lb capacity loading of crane and that outriggers are used to provide total stability for the truck.
4. A 9" dia. hole should be cut out of mounting location (centered with mounting bolts) for access. Reference general dimensions for bolt pattern.
5. Make sure the mounting bolts are 3/4"-16UNF, grade 8. Torque bolts to 335 ft-lbs (dry).
6. When crane is not in operation, a boom support should always be used. Traveling block should be connected to hook loop.
7. See the following page for installation.
8. See the following pages for additional electrical installation.
9. Load test the crane to ensure proper functioning and truck stability
10. Make certain the owner's manual is delivered to the customer.
11. For additional help: call the service department at the Auto Crane Company. (918) 836-0463 (Tulsa, Oklahoma)

### **WARNING**

**FEDERAL LAW** (49 CFR PART 571) REQUIRES THAT THE FINAL STAGE MANUFACTURER OF A VEHICLE CERTIFY THAT HE VEHICLE COMPLIES WITH ALL APPLICABLE FEDERAL REGULATIONS. ANY MODIFICATIONS PERFORMED ON THE VEHICLE PRIOR TO THE FINAL STAGE ARE ALSO CONSIDERED INTERMEDIATE STAGE MANUFACTURING AND MUST BE CERTIFIED AS TO COMPLIANCE. THE INSTALLER OF THIS CRANE AND BODY IS CONSIDERED ONE OF THE MANUFACTURERS OF THE VEHICLE. AS SUCH A MANUFACTURER, THE INSTALLER IS RESPONSIBLE FOR COMPLIANCE WITH ALL APPLICABLE FEDERAL AND STATE REGULATIONS, AND IS REQUIRED TO CERTIFY THAT THE VEHICLE IS IN COMPLIANCE.

**IT IS THE FURTHER RESPONSIBILITY** OF THE INSTALLER OF THE CRANE TO COMPLY WITH THE OSHA TRUCK CRANE STABILITY REQUIREMENTS AS SPECIFIED BY 29 CFR PART 1910.180 (C) (1).

# 4004EH GENERAL ASSEMBLY HARDWIRED—P/N:404181001

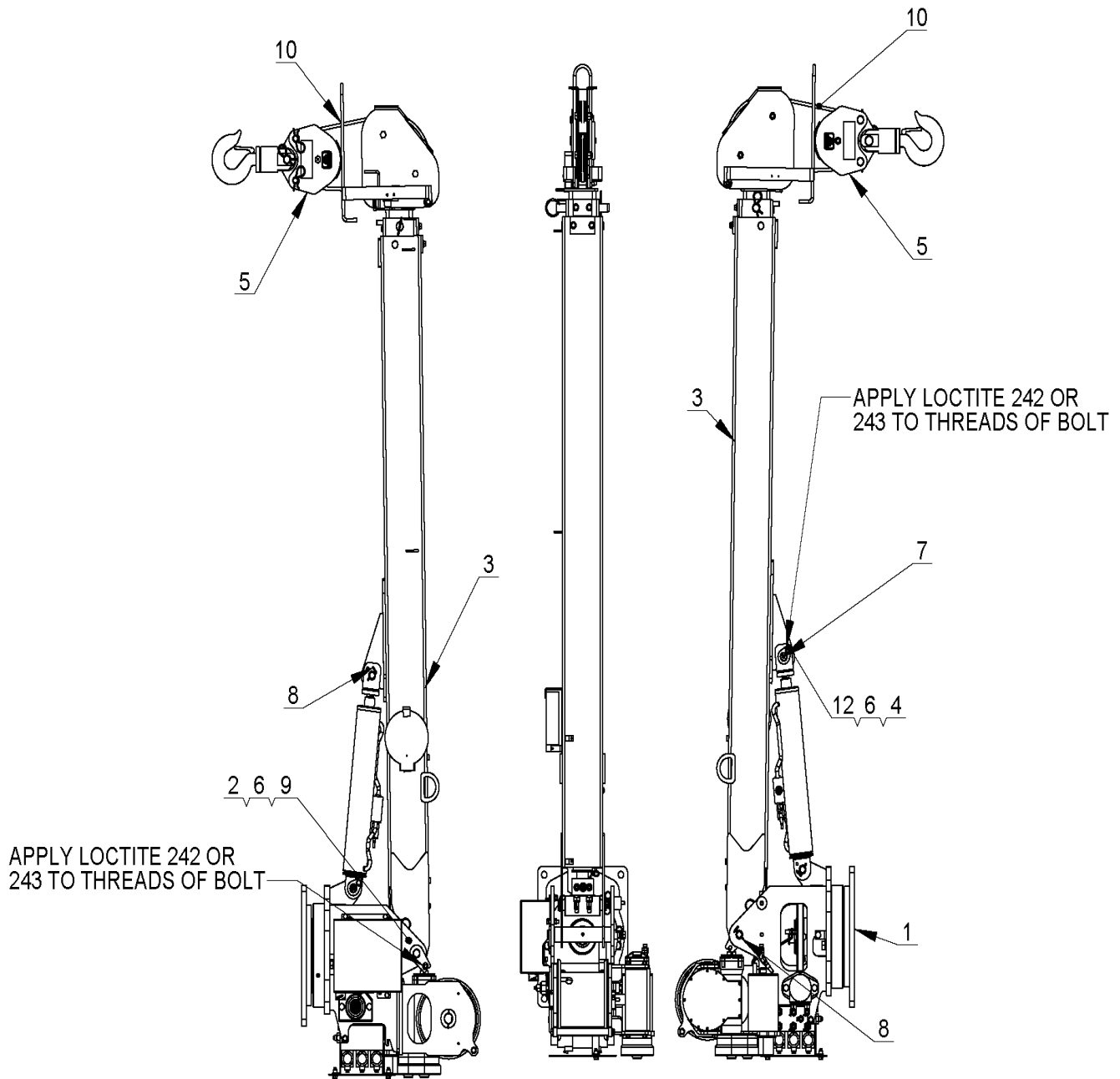

**4004EH GENERAL ASSEMBLY  
HARDWIRED—P/N:404181001**

ITEM NO.	QTY	PART NO.	DESCRIPTION
1	1	404181002	PEDESTAL ASSY, 4004EH
2	1	404220000	PIN WDMT BOOM/PED
3	1	404189000	BOOM ASSY 4004
4	1	320824000	PIN, LIFT CYLINDER
5	1	404211000	TRAVELING BLOCK ASSY, 4004
6	2	212000000	WASHER FL 3/8
7	1	239000000	ZERK DRIVE GR
8	2	360678000	PIN, 3/16 COTTERLESS RING
9	1	910900000	SCREW HX HD 3/8-16UNC X 1 1/2 LG
10	1	360155000	ROPE ASSY
11	1	330372000	NUT HX 3/8-16UNC
12	1	366158000	SCW HX 3/8 NC X 3/4 GR8
*13	1	404222000	SHIP KIT 4004EH,HW
*14	1	404209000	DECAL LAYOUT, 4004EH
*	ITEM NOT SHOWN		

# 4004EH PEDESTAL ASSEMBLY

## P/N: 404190000

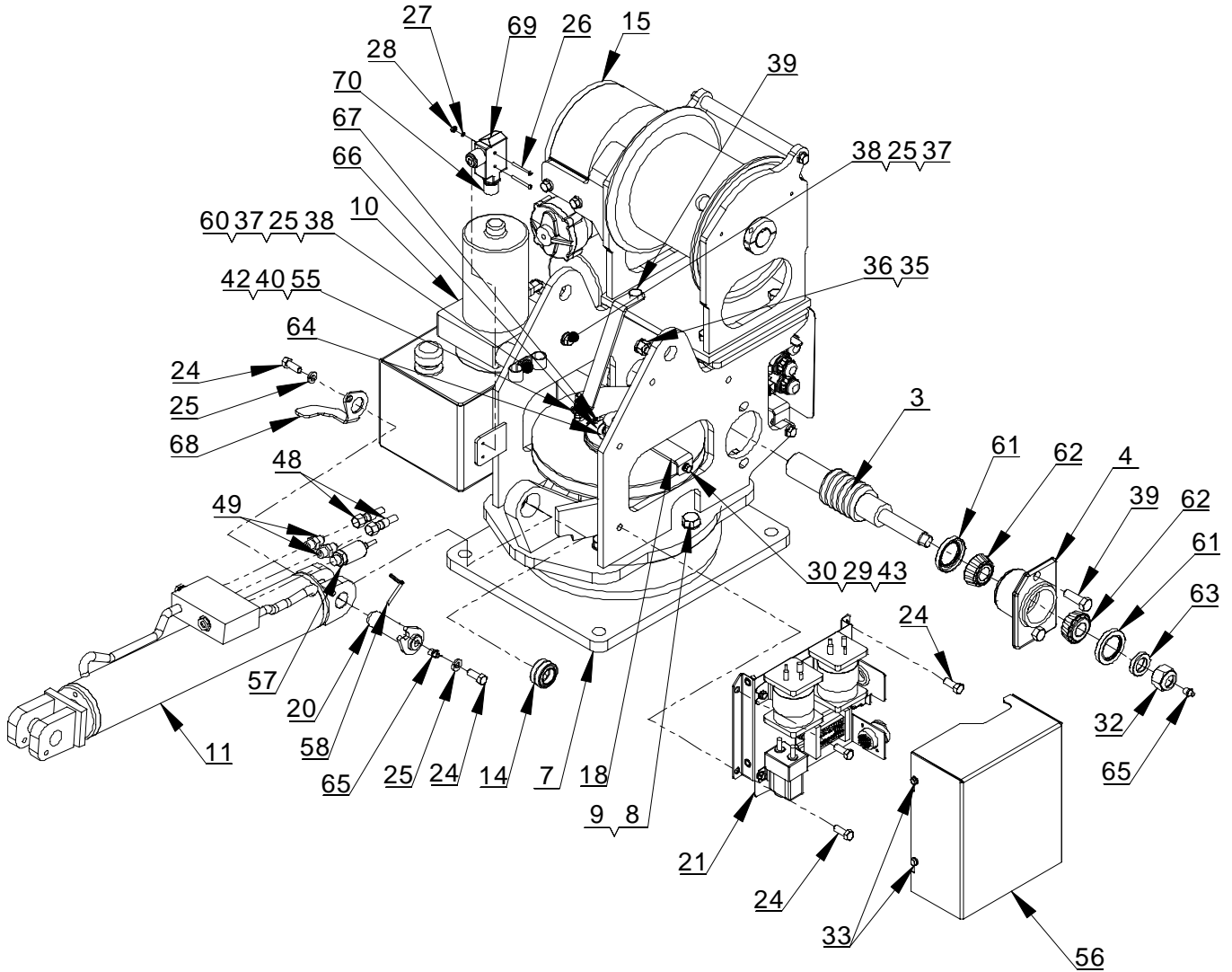

HYDRAULICS:  
 PORT B-1 RETRACT  
 PORT B-2 BOOM UP  
 PORT B-3 CCW REAR MOTOR  
 PORT A-1 EXTEND  
 PORT A-2 BOOM DOWN  
 PORT A-3 CC FRONT MOTOR

CYLINDER SEAL KIT: 366342001  
 C'BAL CARTRIDGE: 480188000

# 4004EH PEDESTAL ASSEMBLY

## P/N: 404190000

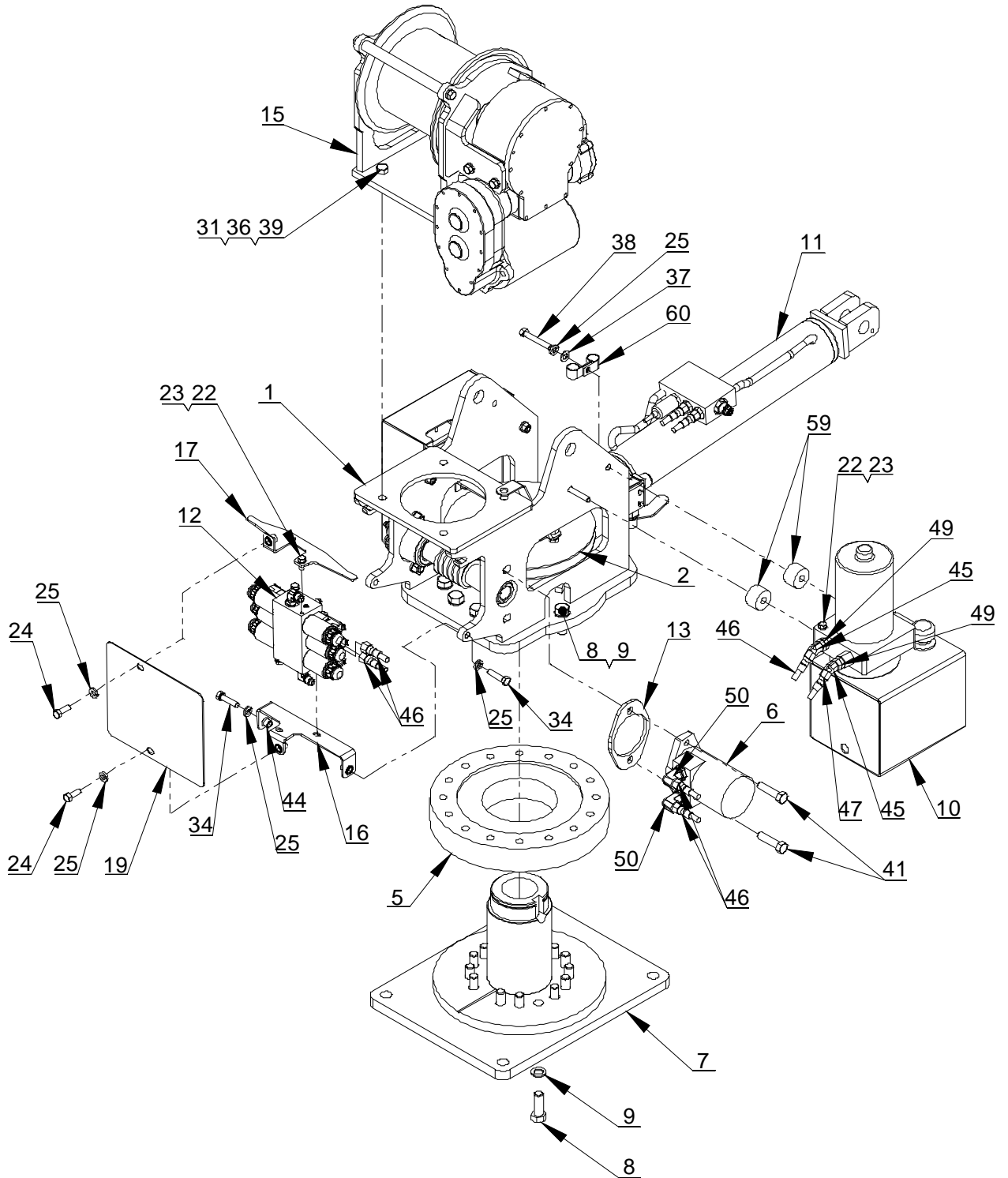

# 4004EH PEDESTAL ASSEMBLY

## P/N:404181002

ITEM NO.	QTY	PART NO	DESCRIPTION
1	1	404188000	PEDESTAL WELDMENT, 4004EH
2	1	404193000	BASE WLDMNT, 4004
3	23	239020000	WASHER FL 5/8 HARDENED
4	23	121980000	SCREW HX HD 5/8-11UNC X 1 3/4 LG GR8
**5	1	320989236	BRACKET, POWER UNIT, 4004 EH
6	1	320845000	CYLINDER, LIFT
7	1	320989420	VALVE ASSY, 3 SPOOL
8	1	330483000	SPACER
9	1	320858000	BEARING, SPHERICAL 1.00 ID
10	1	113003000	HOIST ASSEMBLY
11	1	404188009	LOWER VALVE BRACKET, 4004H
12	1	404188008	UPPER VALVE BRACKET, 4004 EH
13	1	404195000	UPPER TWECO BRACKET WLDMT, 4004
14	1	366688000	COVER, REAR
15	1	320824000	PIN, LIFT CYLINDER
16	1	404187000	SPRING PLATE, GROUND BRUSH, 4004
17	1	404202000	COVER, RELAY PANEL, 4004
18	7	116030000	SCREW HX HD 1/2-13UNC X 1 3/4 LG
19	1	360678000	PIN, 3/16 COTTERLESS RING
20	1	404214000	SPACER, HYD TANK
21	2	480024000	MOUNT PENDANT CABLE RETAINER
22	5	206010000	WASHER SP LK 5/16
23	4	330252000	SCREW HX HD 5/16-18UNC X 3/4 LG GR5
24	2	239300000	ZERK, GREASE
25	1	330472000	CUP HOUSING WITH CUPS
26	1	404213000	SEAL, 2.50 OD X 1.5 ID
27	1	404028000	RETAINING RING, SNAP RING
28	1	340602000	KEY, 3/4 SQ X 1
29	2	330486000	SEAL, OIL
30	2	330485000	BEARING, CONE
31	1	320879000	SPACER ROTATION
32	1	366440000	ROTATION MOTOR
33	1	320878000	ROTATION BEARING
34	1	404016000	WORM GEAR
35	1	404015000	WORM SHAFT
36	1	404194000	PRESSURE SWITCH, NC, 3200 PSI, 4004
37	1	404197000	RELAY PANEL ASSY, 4004EH
*	ITEMS NOT SHOWN		
**	ITEMS LOCATED IN KIT		



# 4004EH PEDESTAL ASSEMBLY

## P/N:404181002

ITEM	QTY	PART NO	DESCRIPTION
*38	1	320929000	CABLE ASSEMBLY #4 X 11 LG
*39	1	404224000	CABLE ASSY 11 IN, TWECO TO
40	1	404228000	CABLE, GROUND WINCH, 15in
41	1	680155100	KIT-ELECTRICAL, 4004EH
42	1	202000000	WASHER SP LK 1/4
43	1	550000000	SCREW HX HD 1/4-20UNC X 3/4 LG
44	2	212000000	WASHER FL 3/8
45	6	330371000	SCREW HX HD 3/8-16UNC X 1 LG
46	1	190000000	NUT HX NYLK 7/8-14UNF
47	3	360493000	SCREW HX WHIZ-LK 1/4-20UNC X
48	2	910900000	SCREW HX HD 3/8-16UNC X 1 1/2
49	5	215000000	WASHER, SP LK 1/2
50	9	177010000	NUT HX 1/2-13UNC
51	4	216000000	WASHER FL 1/2
52	1	404229000	SCR HX HD 3/8-16UNC X 2 1/2LG,
53	2	116080000	SCREW HX HD 1/2-13UNC X 2 LG
54	1	404198000	SCREW HX HD 3/8-16UNC X 1 1/2
55	1	736272000	NUTSERT 1/4-20UNC X .027-.165
56	4	736274000	NUTSERT 3/8-16UNC X .027-.15
*57	1	320988251	KIT, HYDRAULIC, 3203 PRX
**58	3	200876000	FITTING 6 SAE/6 JIC STRAIGHT
**59	2	490198000	FITTING 10SAE(M)/6JIC ELBOW 90
**60	1	480195000	FITTING 45 6-SAE/6-JIC
**61	4	812026016	HOSE ASSY -4 HOSE -6 FEMALE
**62	1	812026018	HOSE ASSY
**63	2	812026031	HOSE ASSY -4 HOSE -6 FEMALE
**64	2	760203000	FITTING, STR, -6 SAE/6 JIC
**65	5	330372000	NUT HX 3/8-16UNC
*	ITEMS NOT SHOWN		
**	ITEMS LOCATED IN KIT		

# 4004EH-20FT BOOM ASSEMBLY

## P/N: 404240001

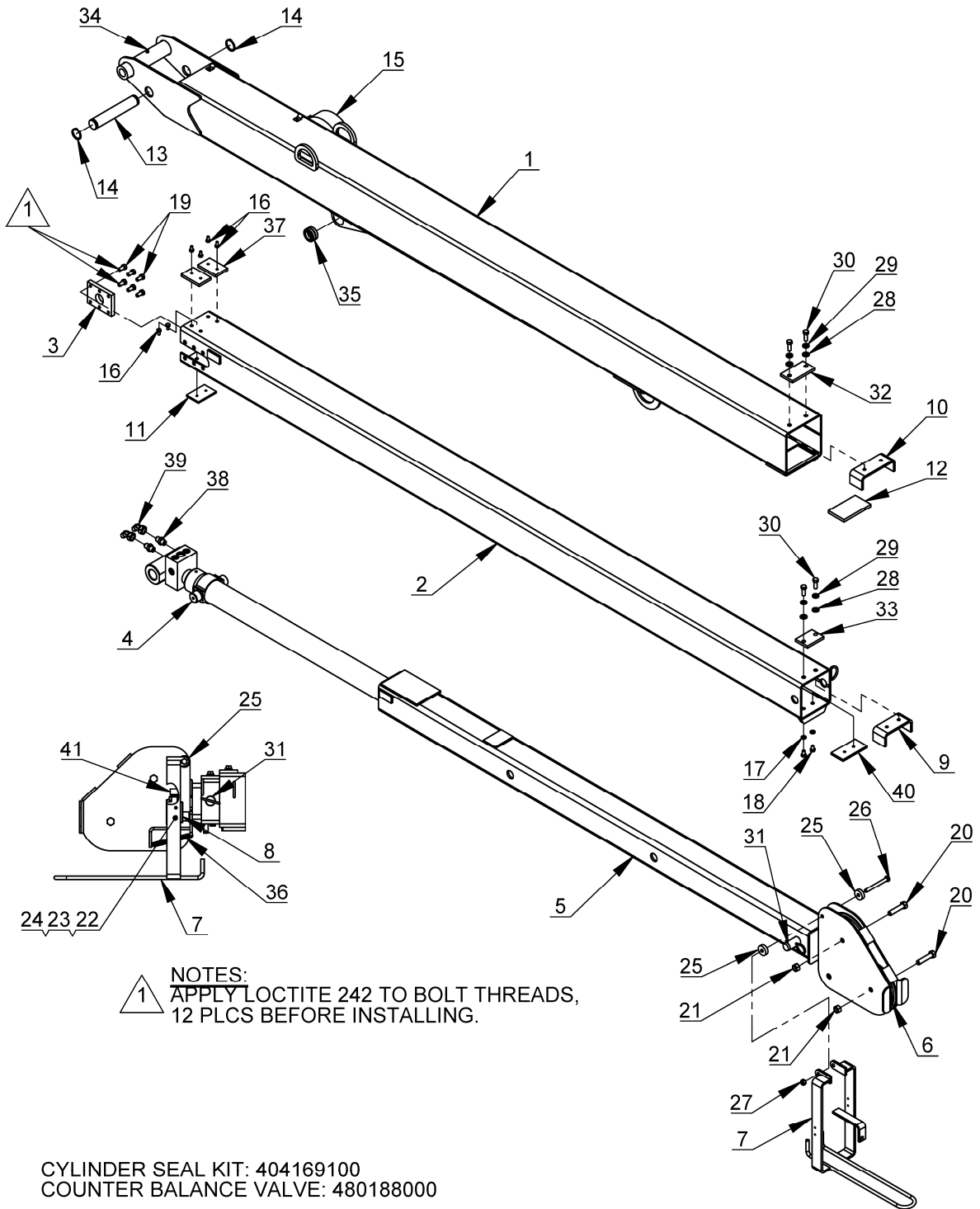

# 4004EH-20FT BOOM ASSEMBLY

## P/N: 404240001

ITEM NO.	QTY.	PART NO.	DESCRIPTION
1	1	404240002	LOWER BOOM WELDMENT, 4004EH (20FT)
2	1	404240004	MID BOOM WELDMENT, 4004EH (20FT)
3	2	366184000	RETAINER, EXTENSION CYLINDER
4	1	404240010	CYLINDER, EXTENSION, 72 INCH STROKE
5	1	404186000	UPPER BOOM WLDMT 4004
6	2	480130000	SHEAVE ASSY
7	1	360823000	2-BLOCK WDMT 5005EH
8	1	646900000	SWITCH, LIMIT ANTI-TWO BLOCK
9	1	366112000	STOP UPPER BOOM
10	1	366183000	STOP CENTER BOOM
11	1	480120000	KB PAD
12	1	360791000	WEAR PAD 4.5 X 2.63 X .35
13	1	404204000	PIN 1-1/4 DIA X 7.163 LG, 4004
14	2	480029000	RING RETAINING
15	1	404205000	CORD REEL ASSY
16	6	005406000	SCREW HX HD 1/4-28UNF X 1/2 LG
17	2	020600000	WASHER 5/16 LOCK SS
18	2	007808000	SCREW 5/16-24UNF X 1/2 LG
19	12	008400000	SCREW HX HD 3/8-16UNC X 3/4 LG GR 5
20	2	011511000	SCREW HX HD 1/2-20UNF X 2 1/4 LG GR5
21	2	017700000	NUT LK 1/2-16UNF
22	2	000610000	SCW RD HD #6 NC X 1.50 LG
23	2	019600000	WASHER SP LK #6
24	2	015400000	NUT HX #6-32UNC
25	2	360852000	SPACER 3/8 ID x 1.250 OD x 3/8 LG
26	1	009800000	SCREW HX HD 3/8-24UNF X 3 1/2 LG GR 5
27	1	01740000	NUT HX NYLK 3/8-24UNF CP
28	4	021200000	WASHER FL 3/8
29	4	021100000	WASHER SP LK 3/8
30	4	008800000	SCREW HX HD 3/8-24UNF X 1 LG
31	1	366190000	PIN ASSY W/LANYARD
32	1	366201000	WEAR PAD 3 .75 X 2.00 X .313
33	1	366202000	PAD, BOOM TOP
34	1	239000000	ZERK DRIVE GR
35	1	320858000	BEARING, SPHERICAL 1.00 ID
36	1	360824000	SPRING, EXTENSION, 4.0"
37	2	480036000	PAD BOOM SIDE
38	2	200876000	FITTING 6 SAE/6 JIC STRAIGHT
39	2	330647000	FITTING -6JIC SWIVEL NUT 45 DEG ELBOW
40	1	366199000	PAD BOOM
41	1	642918000	CORD CONNECTOR

# ***NOTES***

# 4004EH HOIST ASSEMBLY

## P/N: 113003

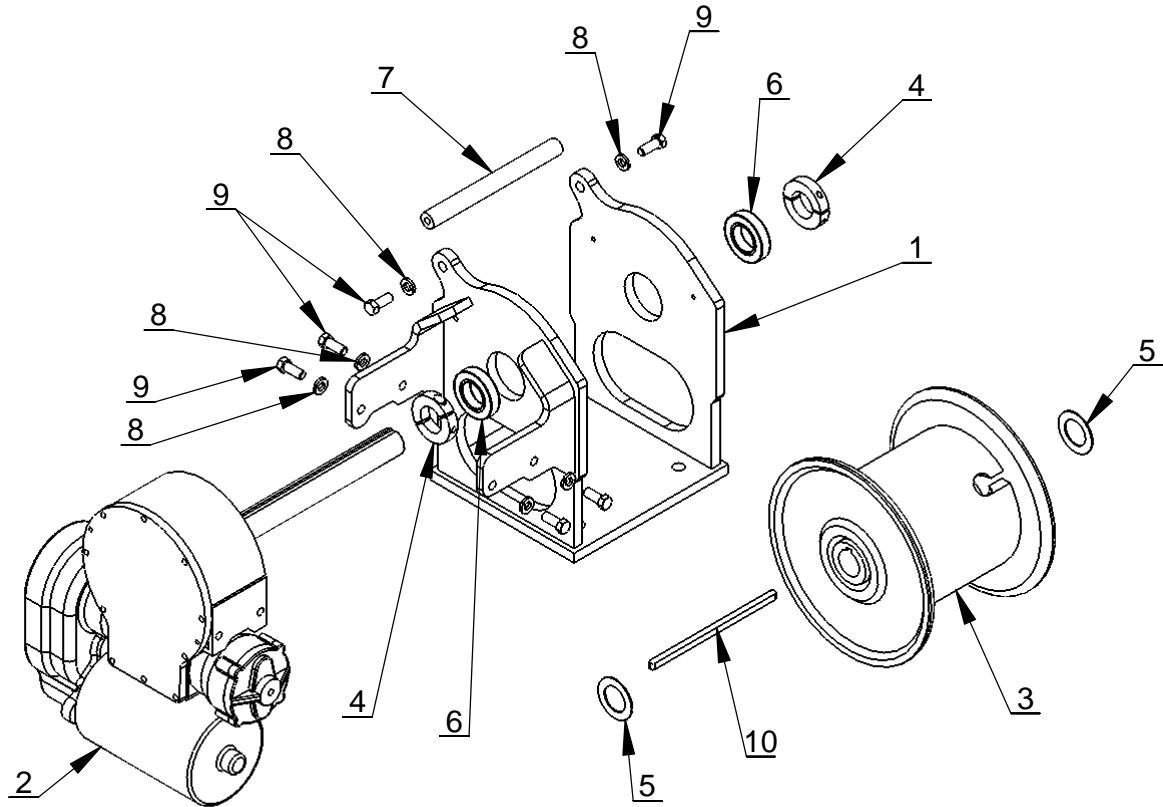

ITEM NO.	QTY.	PART NO.	DESCRIPTION
1	1	366656000	HOIST FRAME
2	1	297036	GEAR HSG/SPUR GEAR HSG/MTR
3	1	366660000	DRUM WELDMENT
4	2	330468	COLLAR, SPLIT 1.25 I.D.
5	2	320887000	BEARING, BRONZE
6	2	400500	BEARING 1.25 I.D.
7	1	366659000	TIE BAR, HOIST ASSEMBLY
8	6	021100	WASHER SP LK 3/8
9	6	330371	SCW HX 3/8 UNC X 1 GR8
10	1	360557	KEY, 5/16 X 7 1/2

# 4004EH HOIST ACTUATOR

## P/N: 297036

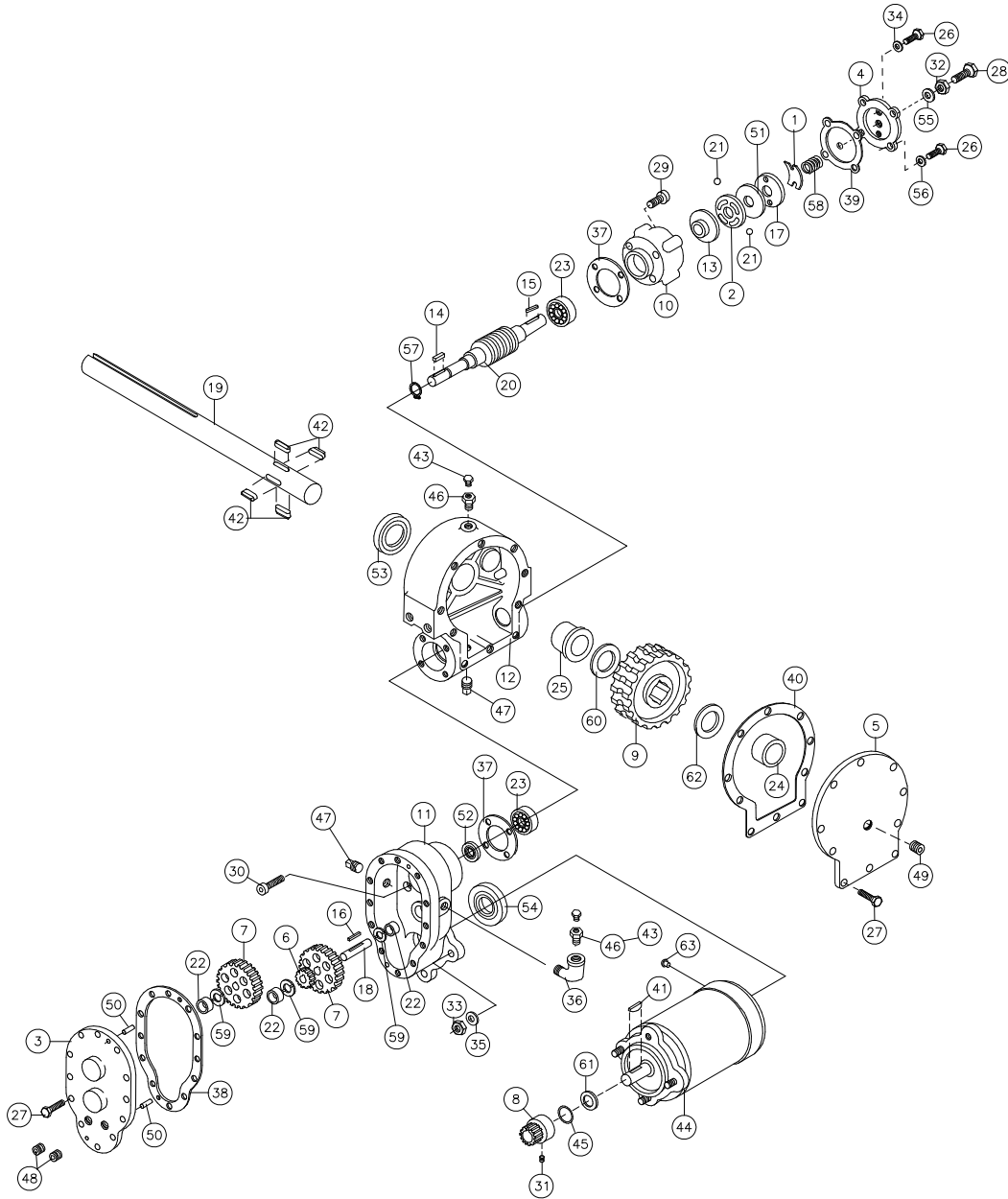

# 4004EH HOIST ACTUATOR

## P/N: 297036

ITEM NO.	QTY.	PART NO.	DESCRIPTION
1	1	306034	SPRING FLAT
2	1	314008	PLATE CAM
3	1	324106	COVER SPUR GEAR HOUSING
4	1	328128	COVER BRAKE
5	1	328134	COVER WORM GEAR HOUSING
6	1	334001	IDLER GEAR
7	2	334003	SPUR GEAR
8	1	334129	PINION GEAR
9	1	334165	GEAR WORM RH
10	1	338007	HOUSING BRAKE
11	1	338203	SPUR GEAR HOUSING
12	1	338273	GEAR HOUSING
13	1	340002	HUB BRAKE
14	1	342023	KEY SQ END
15	1	342027	KEY RD END
16	1	342033	KEY SQ END
17	1	352022	PLATE RETAINER
18	1	356901	SHAFT SPUR
19	1	357145	SHAFT OUTPUT
20	1	368200	WORM RH 30:1
21	2	400003	BALL
22	3	402001	BEARING NEEDLE
23	2	402002	BEARING BALL
24	1	412044	BUSHING COVER
25	1	412045	BUSHING HOUSING
26	6	414021	SCREW HX HD 1/4-20UNC X 1 LG GR8
27	22	414038	SCREW HX HD 1/4-20 X 3/4 LG GR5
28	1	414224	SCREW HX HD 3/8-16 X 1 1/2 LG GR5
29	4	414821	SCREW SOC BTN HD 1/4-20 X 7/8 LG
30	4	414845	SCREW SOC HD 1/4-20UNC X 1 LG
31	1	416029	SCREW SET
32	1	418036	NUT JAM 3/8-16UNC
33	3	418040	NUT HX 3/8-24UNF
34	2	418154	WASHER 1/4 FLAT ALUM.
35	3	418177	WASHER LK
36	1	432011	ELBOW 90 DEG
37	2	442184	GASKET
38	1	442185	GASKET
39	1	442189	GASKET
40	1	442205	GASKET
41	1	450001	KEY WOODRUFF
42	4	450016	KEY BARTH
43	2	456008	RELIEF FITTING
44	1	458108	MOTOR 12V

# 4004EH HOIST ACTUATOR

## P/N: 297036

ITEM NO.	QTY.	PART NO.	DESCRIPTION
45	1	462015	O-RING
46	2	468002	REDUCER
47	2	468011	PIPE PLUG SQ HD
48	2	468017	PIPE PLUG SOC HD
49	1	468018	PIPE PLUG SOC HD
50	2	470001	PIN
51	1	474001	PLATE THRUST
52	1	486009	OIL SEAL
53	1	486017	OIL SEAL
54	1	486023	OIL SEAL
55	1	486069	THREAD SEAL
56	4	486070	THREAD SEAL
57	1	490003	SNAP RING
58	1	494007	SPRING
59	3	518002	WASHER THRUST
60	1	518015	WASHER THRUST
61	1	518018	FIBER WASHER
62	1	518040	WASHER THRUST
63	1	480015	RIVET PLASTIC



# 4004EH TRAVELING BLOCK ASSEMBLY

## P/N: 404211000

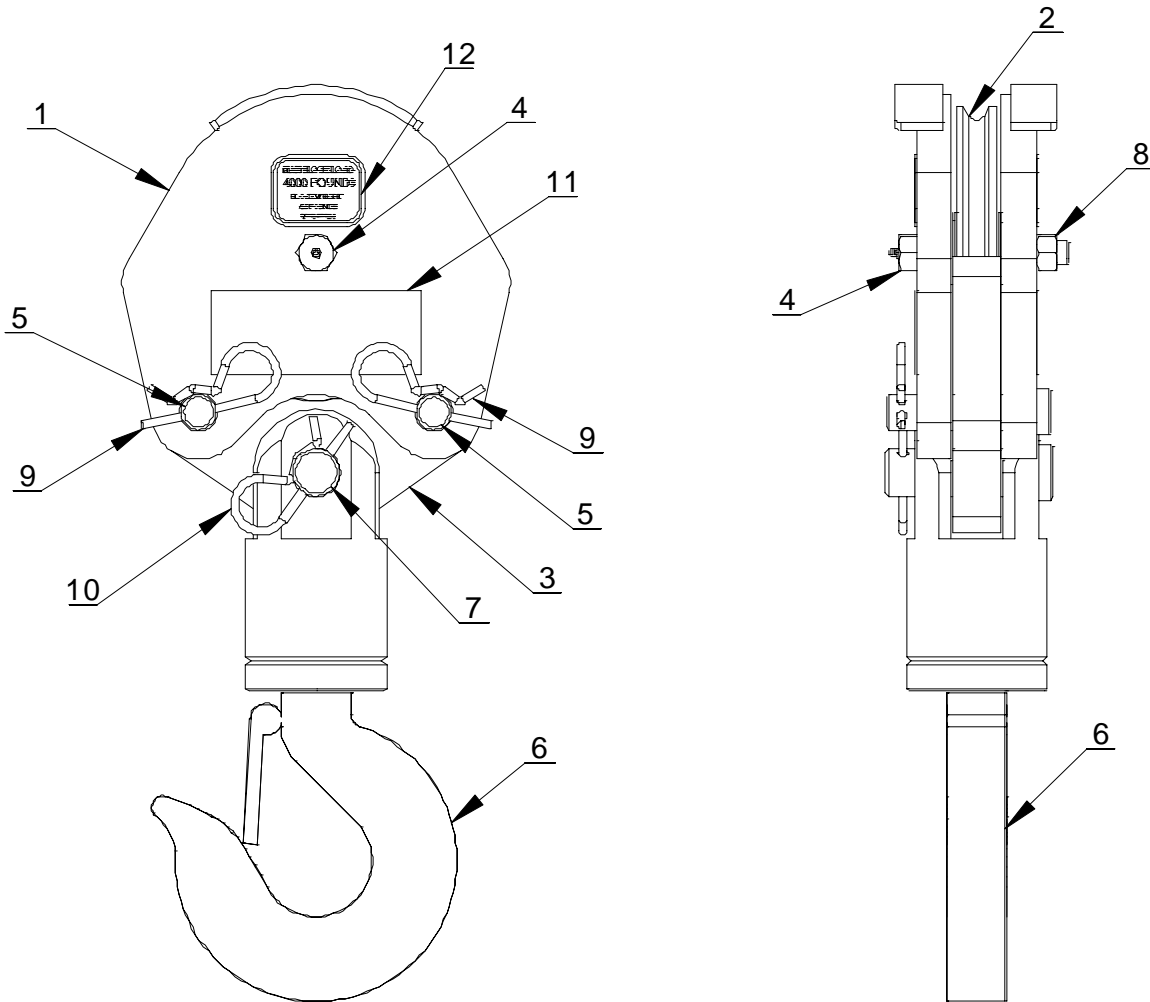

ITEM NO.	QTY.	PART NO.	DESCRIPTION
1	2	480362000	SHORT BLOCK SIDE PL WDMT
2	1	480130000	SHEAVE ASSY
3	1	480364000	TACKLE LOWER
4	1	480372000	BOLT, SHEAVE W/ ZERK FITTING
5	2	480367000	PIN BLOCK
6	1	480371000	HOOK SWIVEL 3 METRIC TON
7	1	480368000	PIN SWIVEL HOOK
8	1	017800000	NUT, HEX-LOCK 1/2-20 NF
9	2	366813000	PIN HITCH
10	1	360124000	PIN HITCH
11	2	040518000	DECAL STAY CLEAR OF LOAD
12	2	404212000	DECAL MAX BLOCK LOAD 4004

# 4004EH RELAY PANEL ASSEMBLY

## P/N: 404197000

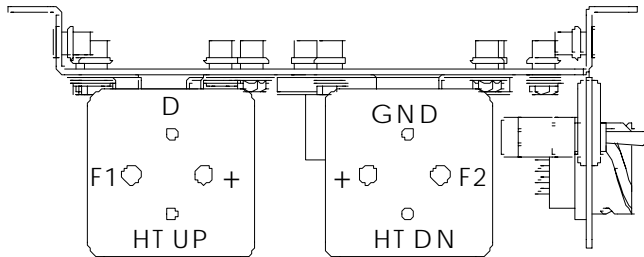

BOOTS REQUIRED

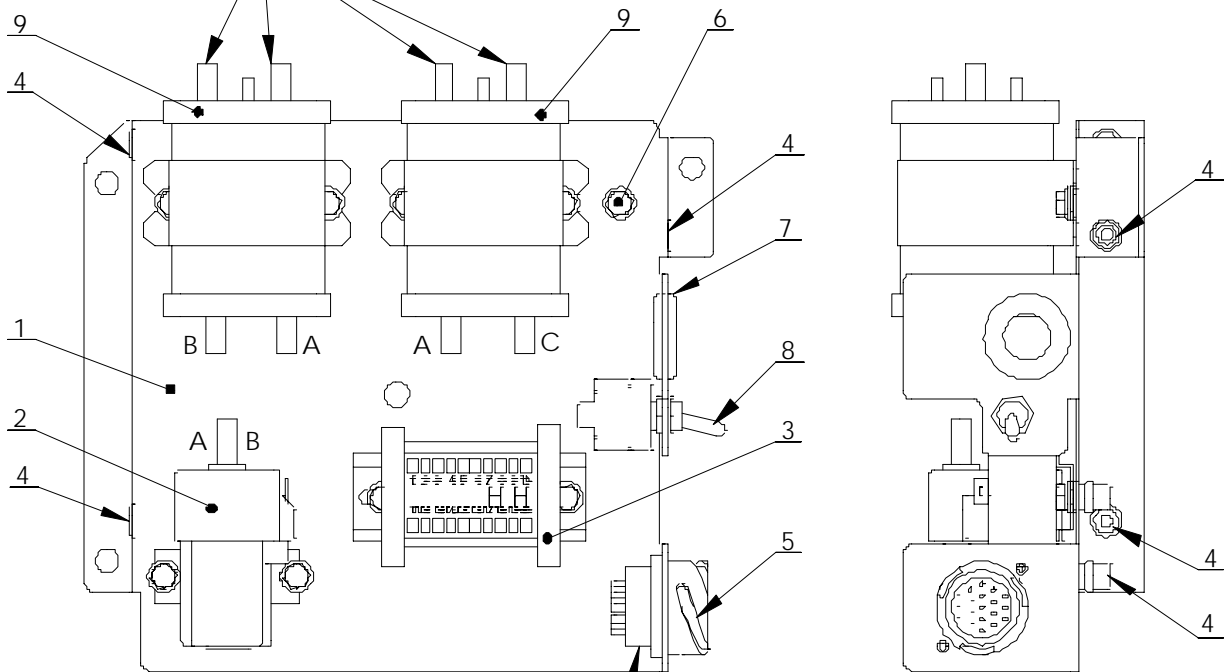

REF FOR REPLACEMENT PART ONLY  
(680171000 RECEPTACLE/WIRE PIGTAIL)

NOTE  
\* NOT SHOWN

ITEM NO.	QTY.	PART NO.	DESCRIPTION
1	1	404203000	BRACKET, RELAY PANEL, 4004
2	1	320584000	RELAY, POWER UNIT
3	1	320804000	TERMINAL STRIP 10
4	12	736272000	NUTSERT .25UNC X .027-.165 GRIP
5	1	366095000	PLUG, 19 PIN
6	10	360493000	SCREW HX WHIZ-LK 1/4-20UNC X 1/2 LG
7	1	371024000	GROMMET 3/4" I.D.
8	1	750090000	TOGGLE SWITCH (ON-ON)
9	2	404167000	SOLENOID, SEALED
*10	1	645000000	TWECO, MALE MODIFIED

# 4004EH ELECTRICAL SCHEMATIC

## P/N: 404197000

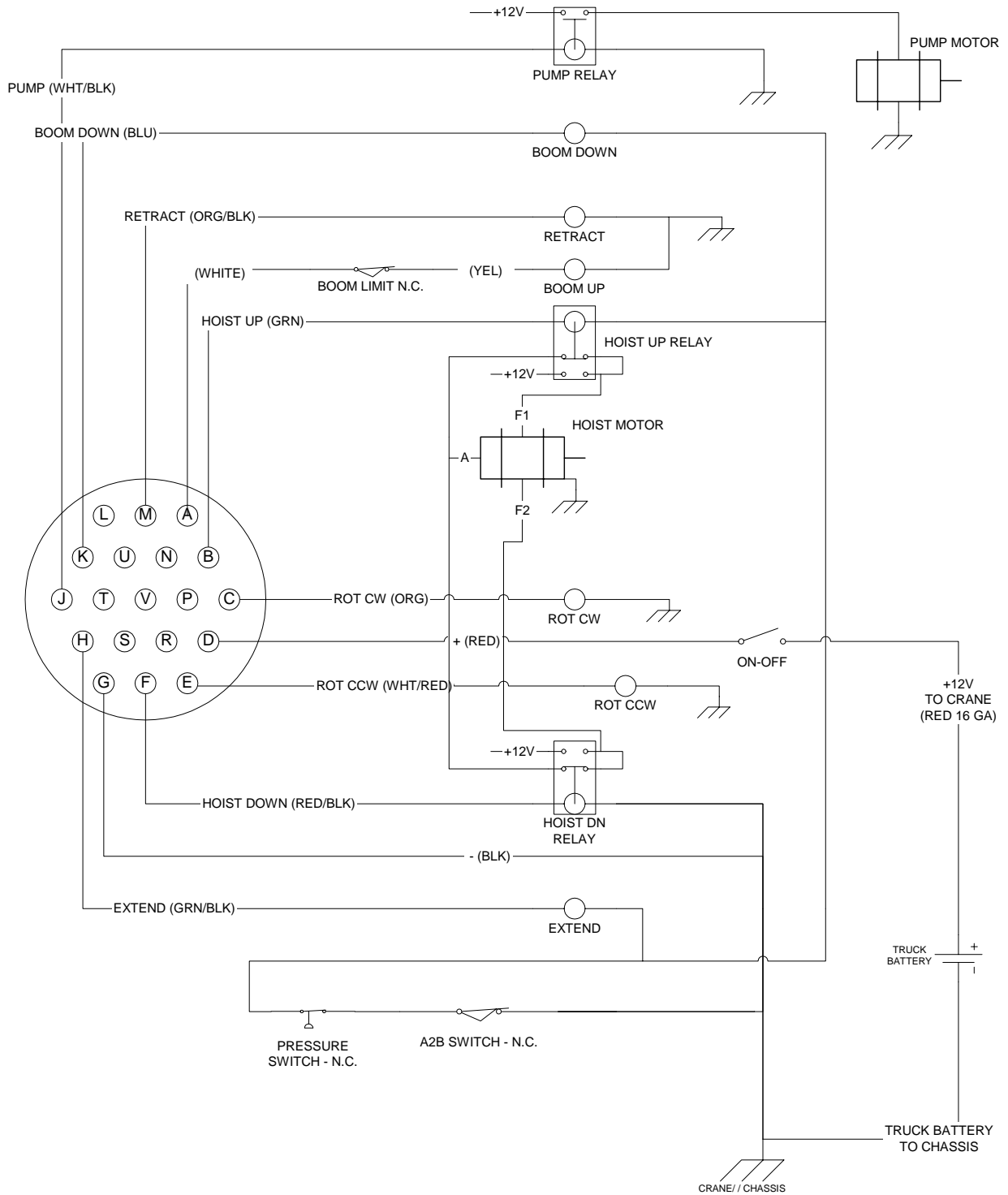

# 40004EH PENDANT 8 FUNCTION W/ ON/OFF SWITCH - P/N: 366709001

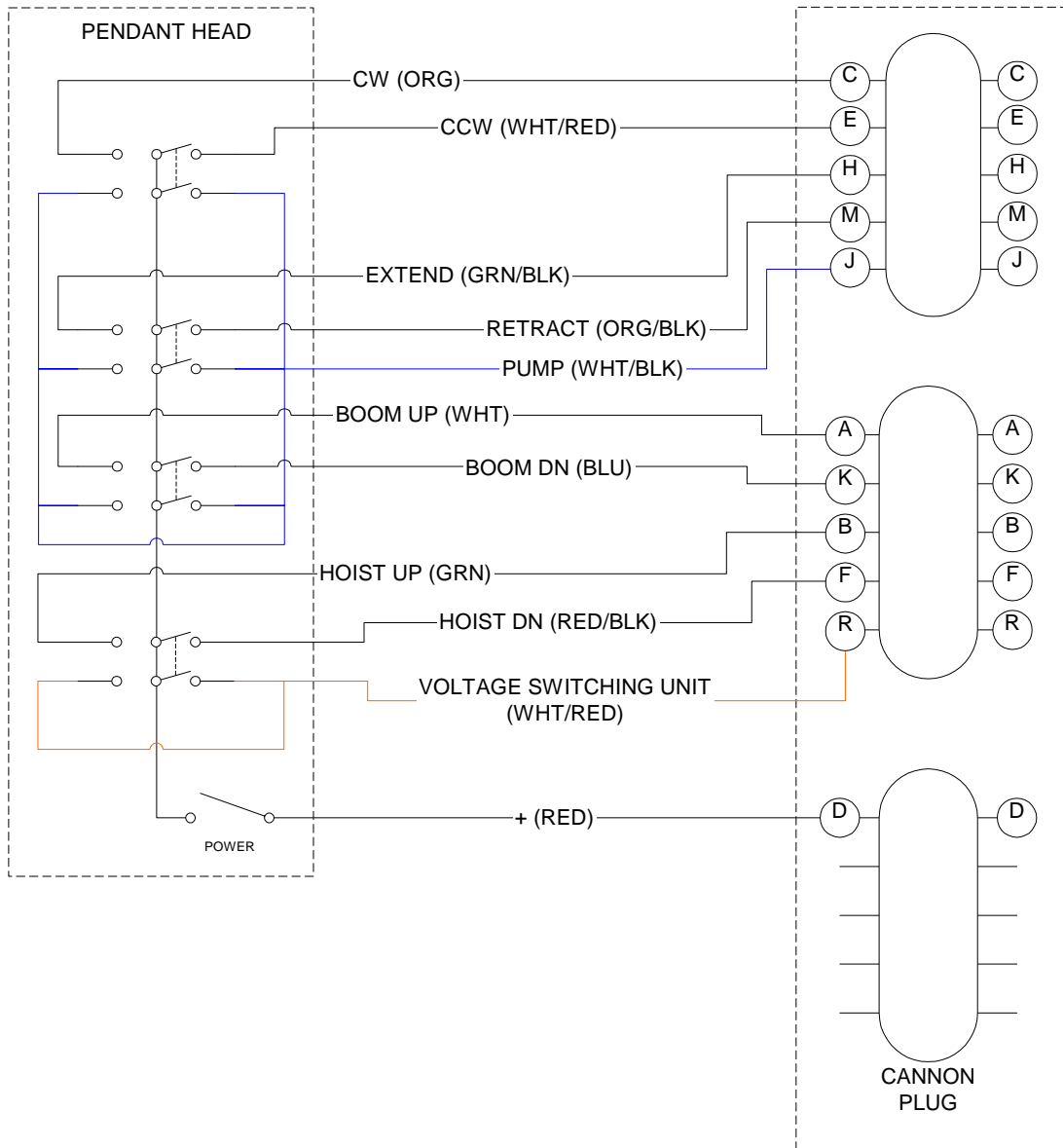

# 40004EH PENDANT 8 FUNCTION W/ ON/OFF SWITCH - P/N: 366709001

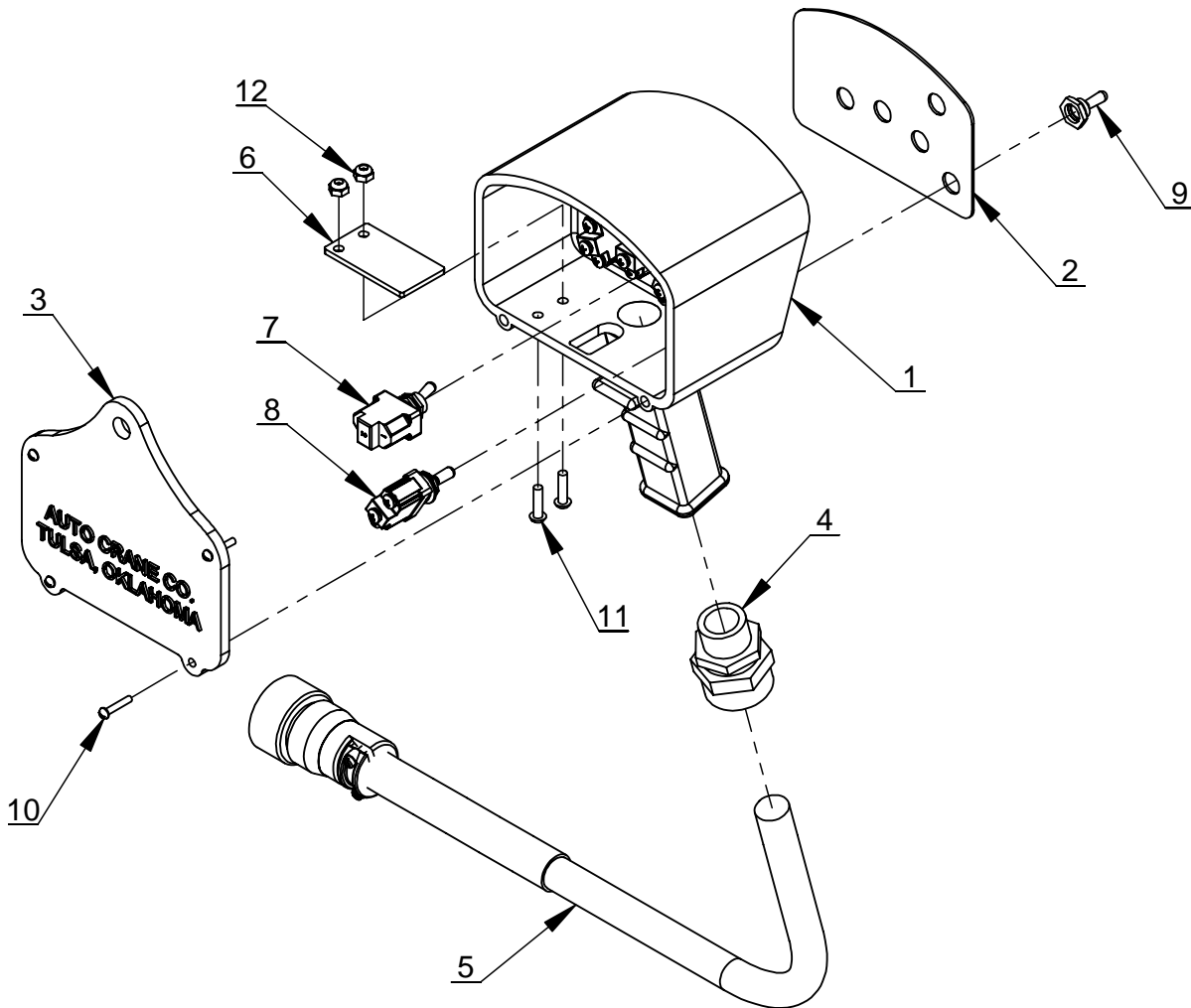

ITEM NO.	QTY.	PART NO.	DESCRIPTION
1	1	480501000	PENDANT HOUSING
2	1	366719000	DECAL, PENDANT 8 FUNC W/PWR
3	1	480504000	PENDANT BACK PLATE
4	1	370433000	CORD CONNECTOR HUBBLE F-3
5	1	680172000	PENDANT CABLE, 19 PIN BAYONET
6	1	480598000	COVER TRIGGER OPENING
7	1	750090000	TOGGLE SWITCH (ON-OFF)
8	4	634200000	TOGGLE SWITCH KIT
9	5	640300000	BOOT, TOGGLE-URETHANE-MID
10	4	001004000	SCW PN HD #6 X 3/4 LG
11	2	002607000	SCREW RD HD #10-24UNC X 3/4 LG CP
12	2	015801000	NUT HX NYLON LOCK #10-24UNC ZP

# ***NOTES***

# 4004EH TWECO W/SWITCH MOUNT

## P/N: 404218000

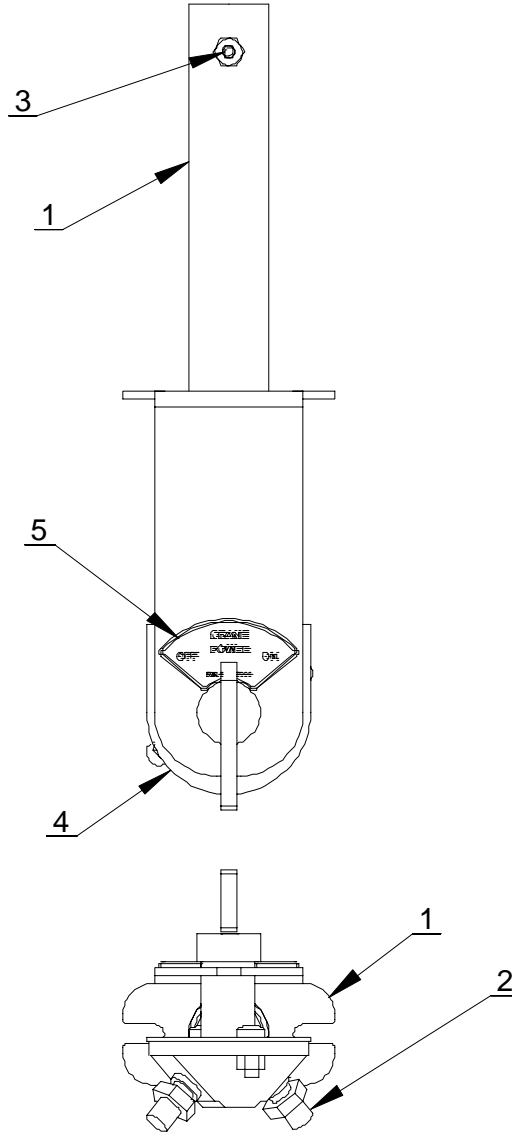

ITEM NO.	QTY.	PART NO.	DESCRIPTION
1	1	404217000	LOWER TWICO WLDMNT W/ SWITCH MNT
2	1	404224000	CABLE ASSY 11 IN, TWECO TO TERMINAL
3	1	002900000	SCREW SET .25-20UNC X .25 LG
4	1	404216000	MASTER SWITCH
5	1	404219000	DECAL, CRANE POWER

# 4004EH HYDRAULIC CONTROL VALVE

## P/N: 320826000

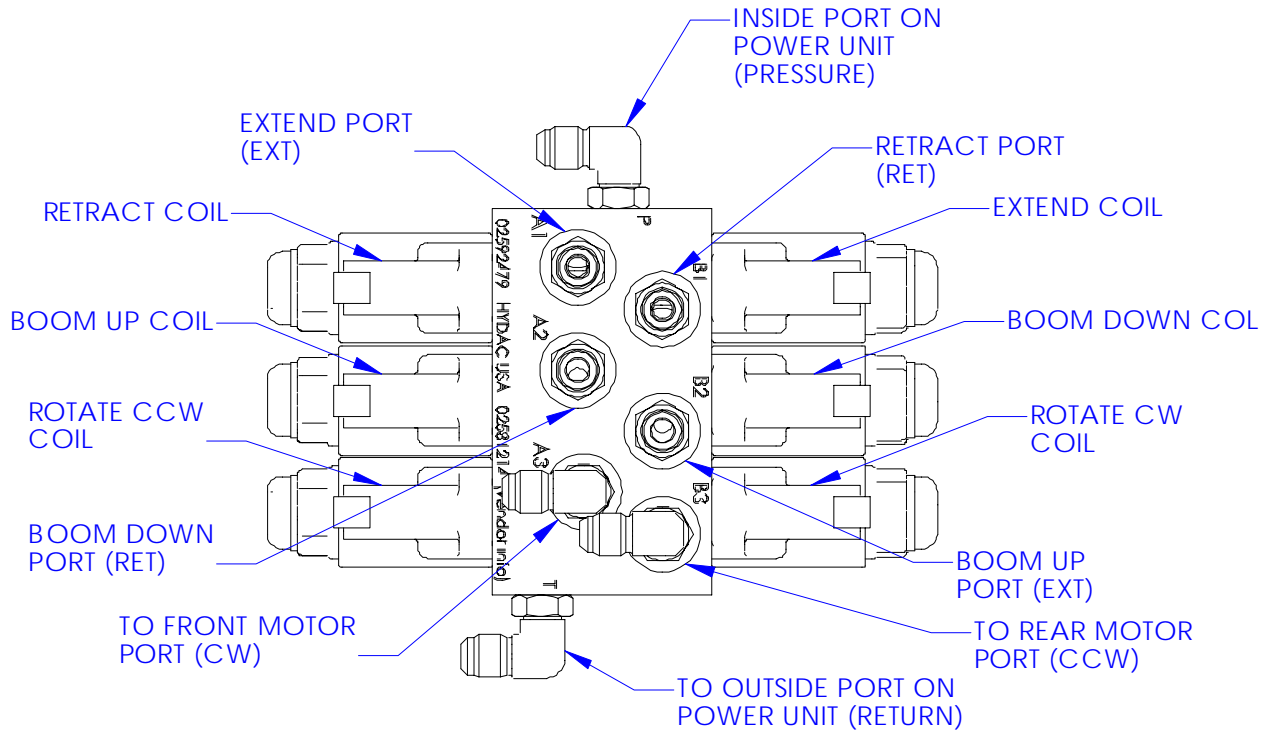

ITEM NO.	QTY	PART NO.	DESCRIPTION
REF	3	320826001	SPOOL VALVE, 4WK06G-12X-0-0-N
REF	6	320826002	SOLENOID COIL, 12DN-50-1836

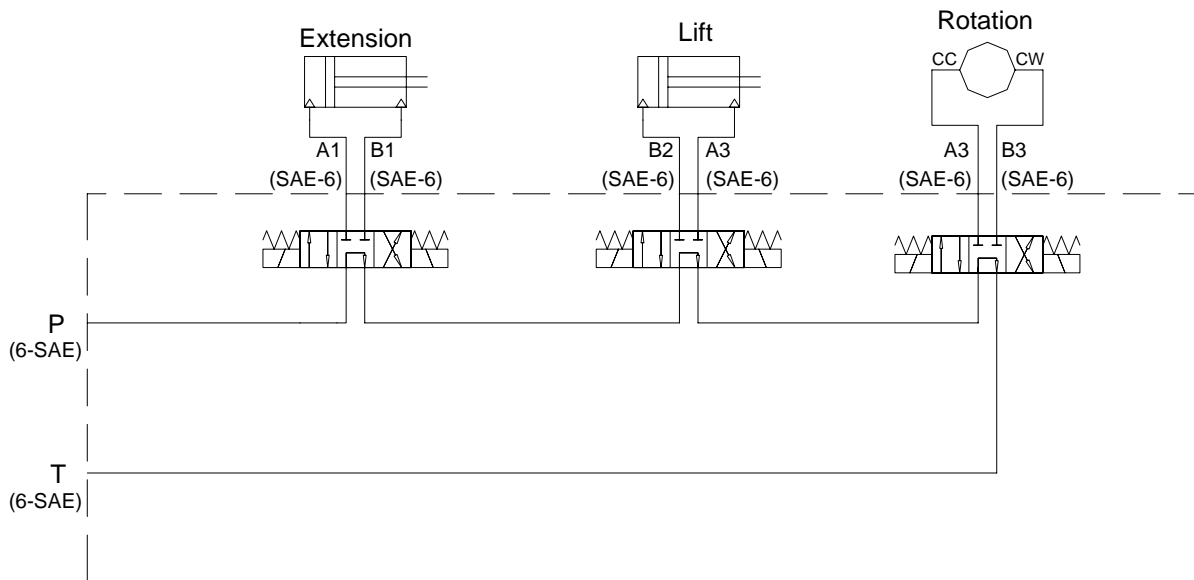



# 4004EH POWER UNIT

## P/N: 320825000

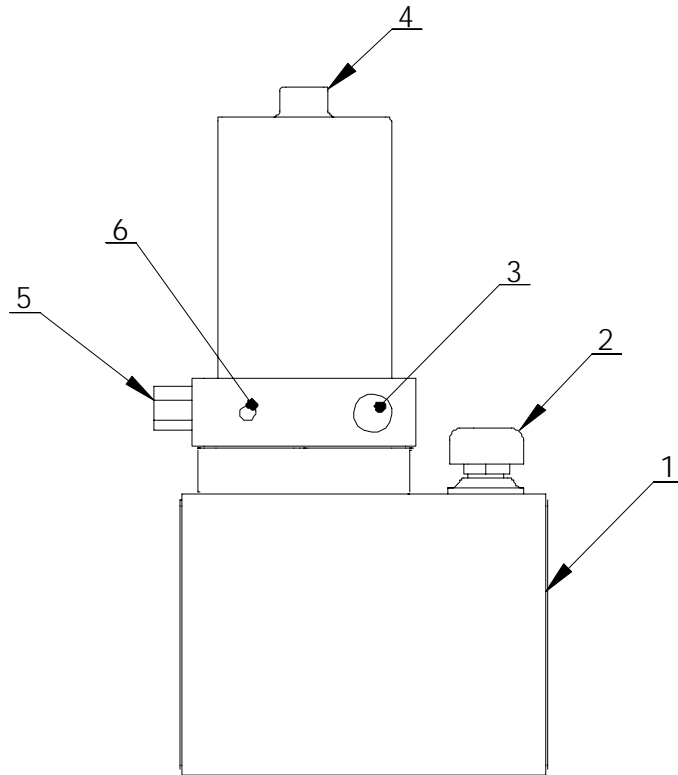

ITEM NO.	QTY.	PART NO.	DESCRIPTION
1	1	320825001	RESERVOIR KIT
2	1	200545000	BREATHER CAP
3	1	320825002	RELIEF VALVE KIT
4	1	320335005	MOTOR
5	1	320336005	RETURN PORT PLUG KIT
6	1	320825003	ADAPTER KIT
REF	1	320335003	PUMP KIT
REF	1	320335010	O-RING

# 4004EH-20FT GENERAL ASSEMBLY

## FM – P/N: 404240000

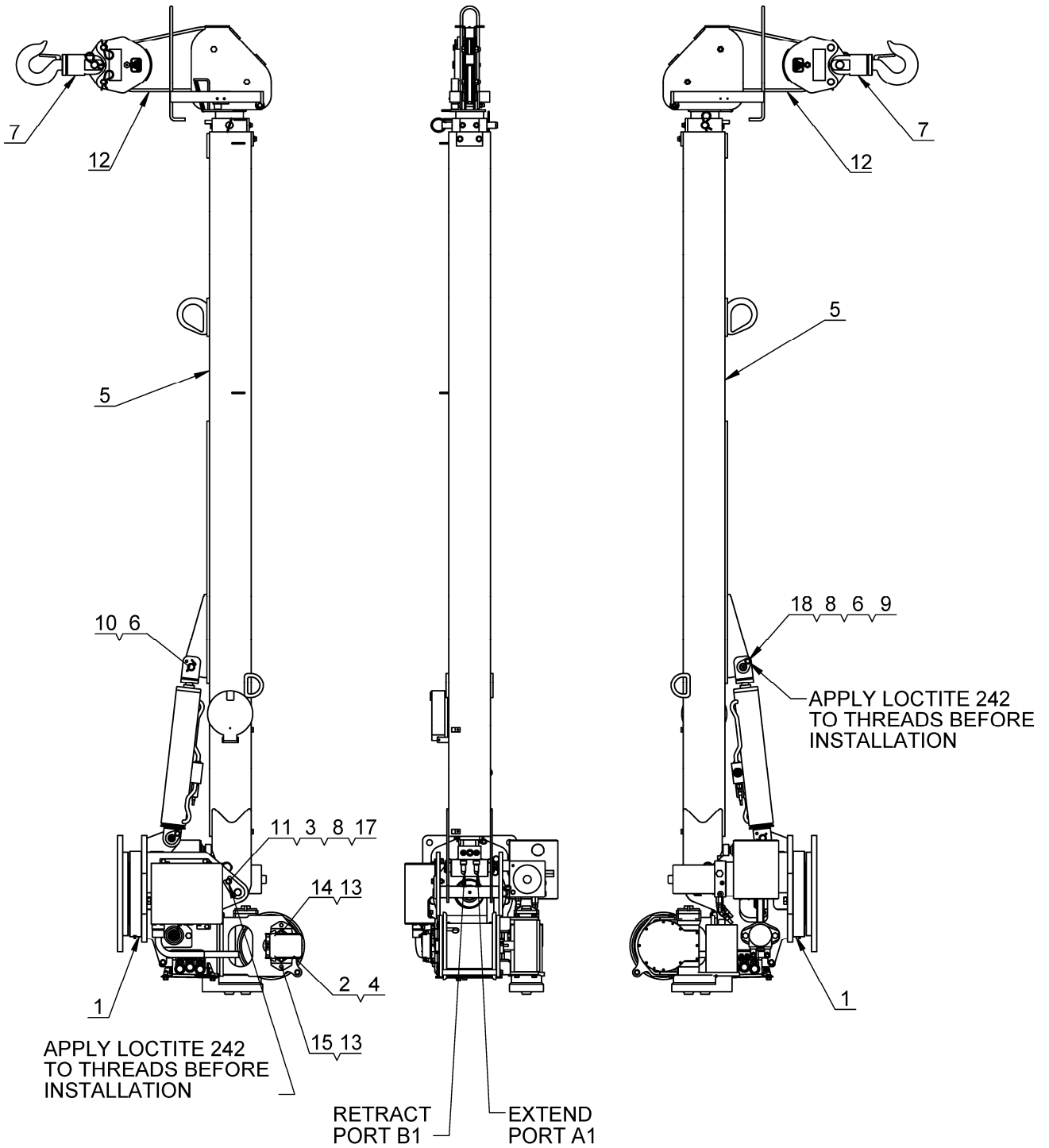

# 4004EH-20FT GENERAL ASSEMBLY

## FM – P/N: 404240000

ITEM NO.	QTY.	PART NO.	DESCRIPTION
1	1	404190000	PEDESTAL ASSY, 4004EH
2	1	460158000	RECEIVER, NON-PROPORTIONAL,
3	1	404220000	PIN WDMT BOOM/PED
4	1	366715000	BRACKET ASSEMBLY, RECEIVER MOUNT
5	1	404240001	4004EH BOOM (20FT)
6	1	320824000	PIN, LIFT CYLINDER
7	1	404211000	TRAVELING BLOCK ASSY, 4004
8	2	021200000	WASHER FL 3/8
9	1	239000000	ZERK DRIVE GR
10	2	360678000	PIN, 3/16 COTTERLESS RING
11	1	009109000	SCREW HX HD 3/8-16UNC X 1 1/2 LG
12	1	404240008	WIRE ROPE, 5/16", 100FT
13	4	020200000	WASHER SP LK 1/4
14	2	005500000	SCREW HX HD 1/4-20UNC X 3/4 LG
15	2	005901000	SCREW HX HD 1/4-20UNC X 1/2 LG
16	1	404206000	HARNESS, FM, 3203PR(X), 4004EH
17	1	330372000	NUT HX 3/8-16UNC
18	1	366158000	SCW HX 3/8 NC X 3/4 GR8
*19	1	404240014	SHIP KIT, 4004EH 20FT BOOM, FM
*20	1	404209000	DECAL LAYOUT, 4004EH
*	ITEM NOT SHOWN		

# FM CONTROL USE AND CARE

## TRANSMITTER LAYOUT

There is a red light to the left of the *ON/OFF Toggle switch* and a yellow light to the right. As the battery runs down, the red light will begin to flash as well as the yellow light.

If the yellow light is rapidly flashing this indicates that the unit is transmitting. Refer to the Transmitter Diagnostics Section for a detailed explanation of each light combination.

In addition to the two lights mentioned above there are four function toggle switches. These functions from left to right are to be used to raise and lower the boom, raise and lower the hoist cable, rotate the crane and extend and retract the boom.



## POWER ON/OFF TOGGLE SWITCH

The transmitter is powered by 4-AA alkaline batteries, located under the back cover of the housing. To turn the transmitter on, press and hold the *Power On Toggle*, release once the transmit light starts blinking. To turn the unit off, press and hold the power off toggle, release after the transmit light stops flashing.

## FUNCTION SWITCHES

To operate a function, toggle one of the function switches with either the thumb of the hand holding the unit or the thumb or fingers of the opposite hand. More than one function can be activated at one time.

## CARE

**KEEP DRY.** Do not clean the transmitter / receiver under high pressure. If water or other liquids get inside the transmitter battery or receiver compartment, immediately dry the unit. Remove the case and let the unit air dry.

## WELDING

**DISCONNECT THE RADIO RECEIVER BEFORE WELDING** on the crane, load, or truck. Failure to disconnect will result in the destruction of the radio receiver.

# FM CONTROL TRANSMITTER - P/N: 460157000

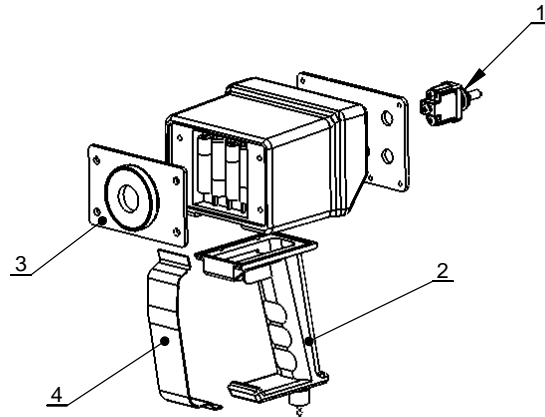

ITEM NO.	QTY.	PART NO.	DESCRIPTION
1	5	460166000	TOGGLE SWITCH KIT (OMNEX)
2	1	460168000	HANDLE, TRANSMITTER W/O TRIGGER
3	1	460163000	COVER, TRANSMITTER BATTERY W/MAGNET
4	1	460162000	GUARD, TRIGGER (OMNEX)

TOGGLE SWITCH WIRING CHART		
FUNCTION	WIRE COLOR	TERMINAL POSITION
POWER ON	YELLOW	BOTTOM
POWER OFF	GREEN (FROM 8 PIN CONNECTOR)	TOP
BOOM UP	RED	BOTTOM
BOOM DN	ORANGE	TOP
BOOM EXTEND	GREEN (FROM 10 PIN CONNECTOR)	BOTTOM
BOOM RETRACT	BLUE	TOP
ROTATE CW	VIOLET	BOTTOM
ROTATE CCW	GREY	TOP
HOIST UP	WHITE	BOTTOM
HOIST DN	BROWN	TOP
COMMON	BLACK	MIDDLE

# ***NOTES***

# 4004EH ELECTRICAL SCHEMATIC

## FM – P/N: 404206000

### ELECTRICAL SCHEMATIC FM

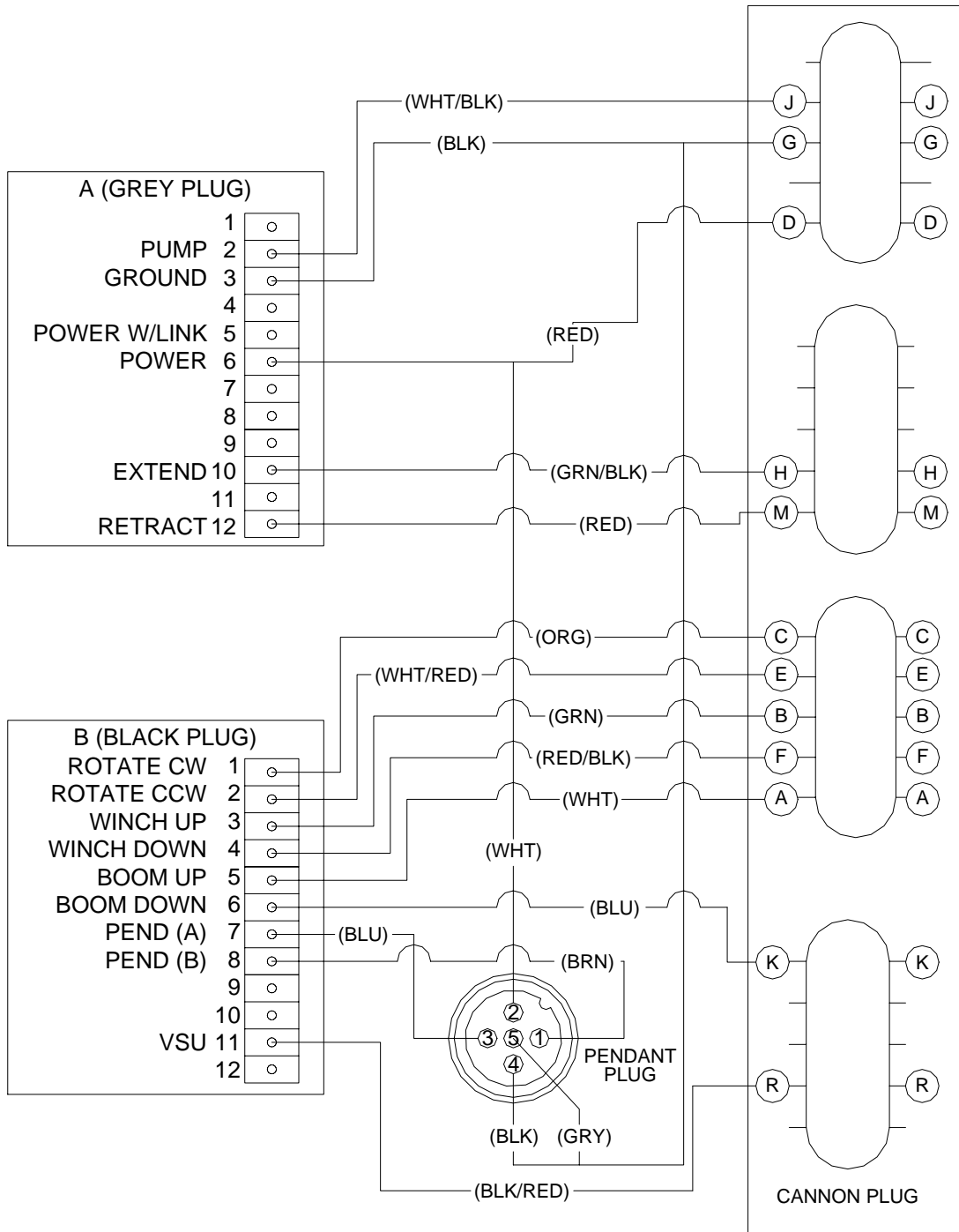

# FM CONTROL TRANSMITTER DIAGNOSTICS

	<p>Tether connection detected</p>
	<p>Low battery. Unit will run approximately 10 hours after Battery light starts flashing.</p>
	<p>Flashing rapidly for 10 seconds indicates a transmitter failure.</p>
	<p><b>Normal Operation</b> The Active light will flash several times per second, indicating that the transmitter is sending signals to the receiver. The Active light will remain on momentarily whenever a function changes</p>
	<p><b>Normal Operation</b> The transmitter is in Download Mode.</p>
	<p>Stuck switch detected. Ensure that all switches are in a centered position. The transmitter will not power up when a function is ON.</p>
	<p><b>On Power Down</b> Unit is still powered. Check for stuck switches, as the transmitter will not power down when a function is ON. Alternating flash means that the transmitter is in Calibration Mode.</p>

<p><b>Light Legend</b></p>	<p>Solid </p>	<p>Slow Flash </p>	<p>Fast Flash </p>	<p>Red Light </p>	<p>Green Light </p>	<p>Yellow Light </p>	
----------------------------	---------------	--------------------	--------------------	-------------------	---------------------	----------------------	--



# FM CONTROL RECEIVER DIAGNOSTICS

## Normal Operation

ESTOP	FAULT	LINK	STATUS	
				Transmitter is OFF If the transmitter is off, the receiver is operating properly.
				Transmitter is ON When the transmitter is turned on, the Link light (fast flashing) and E-Stop (GREEN) indicates the receiver is operating properly
				Transmitter is in Operation When a function is activated on the transmitter, the Fault light will turn on GREEN. This indicates the receiver is operating properly
				Transmitter is OFF When a latched function is activated then the transmitter is turned off, the Fault light will stay on GREEN. If the system was intentionally designed this way, the receiver is operating properly, if not call for service.

## Trouble Indicators

**Note:** In some cases, the indicator lights will be different depending on whether the transmitter is on or off. Please note the transmitter status in the "Description" column for each case.

Indicator Lights	Description	Solution
	Transmitter is ON The reason is the transmitter is not communicating with the receiver.	Refer to <b>Trouble Shooting Chart #3</b> for solutions
	Transmitter is ON A low battery condition has been detected.	To detect intermittent conditions caused by poor or corroded ground or power circuits, the GREEN light will continue to flash for 30 seconds after the condition has been removed.
	Transmitter is ON An internal fault with the E-Stop has been detected.	Check fuse, if OK then: Inspect E-Stop wiring for short circuit. Disconnect E-Stop wire as close to the receiver output as possible. If the Status light changes to: <ul style="list-style-type: none"> <li>GREEN, a short occurs after disconnection point.</li> <li>Stays flashing RED, send it in for service .</li> </ul>
	Transmitter is ON A short to ground or excessive current draw on an output. It is most likely caused by a wiring fault.	Ensure transmitter is functioning properly, check status of each output connection: Press each function button and observe Fault Light. <ul style="list-style-type: none"> <li>If GREEN, everything is OK.</li> <li>If RED, there is a short in that connection.</li> </ul>
	Transmitter is OFF The receiver has detected an internal fault.	Refer to <b>Trouble Shooting Chart #1</b> for solutions
	Transmitter is ON Blown fuse detected. (not functional with proportional units)	Refer to <b>ID Code Section</b> for instructions on how to open the receiver case to access fuse. Check wiring for shorts or bare spots. If fuses continue to blow, call for service.
	A setup failure has occurred.	Either hold the Setup button for 5 seconds to return to Setup mode or cycle power to return to the normal operating mode.
	Transmitter is OFF The receiver is powered incorrectly.	Most likely cause of this condition is that an output wire or the E-Stop wire has been connected to a power source while the power wire is disconnected from the Power Input (A6). I.E. Receiver is being powered from an output and not Power Input.

Light Legend	Solid	Slow Flash	Fast Flash	Red Light	Green Light	Yellow Light
--------------	-------	------------	------------	-----------	-------------	--------------

# FM CONTROL TROUBLESHOOTING CHART 1

## Test the Receiver—R160

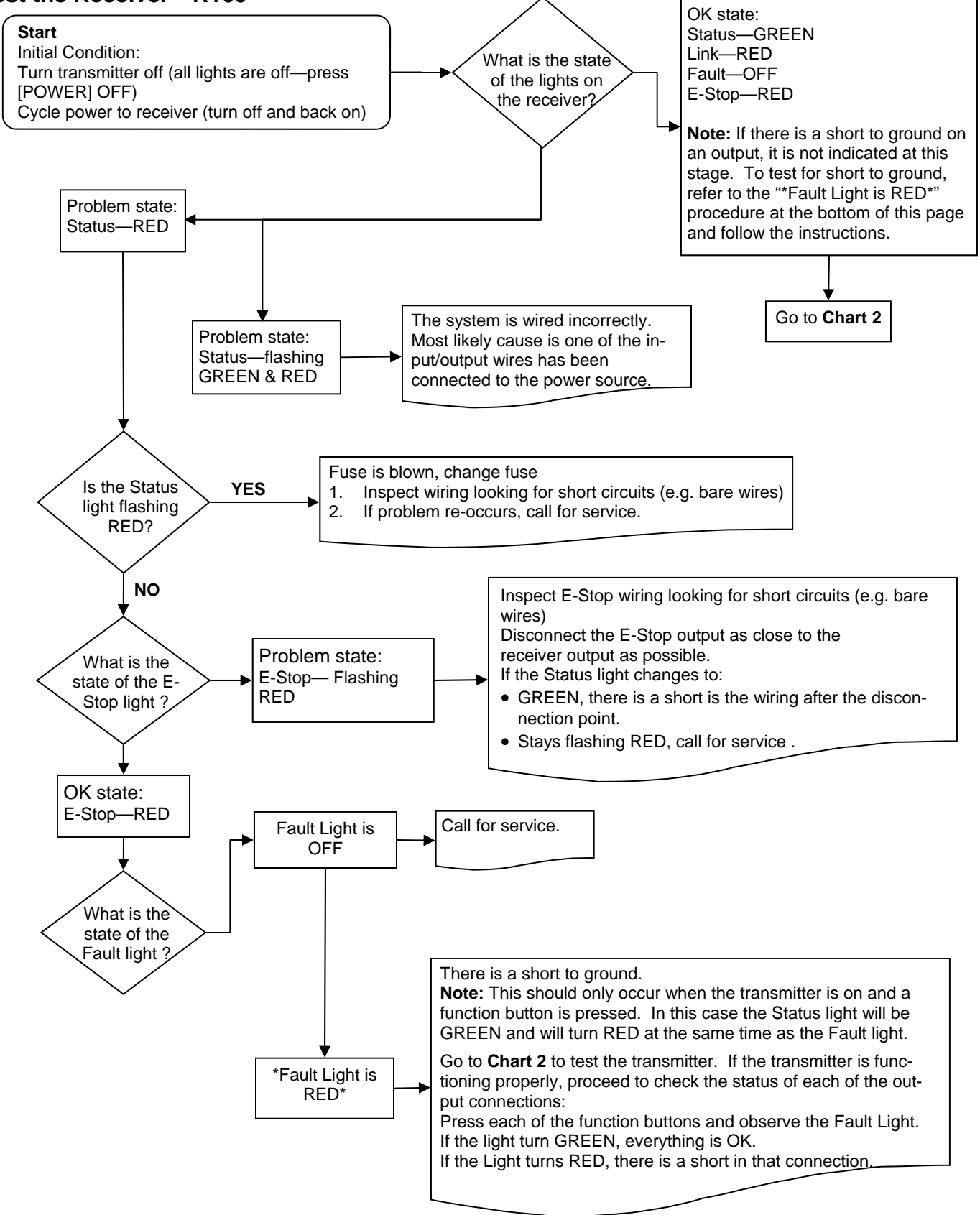

# FM CONTROL TROUBLESHOOTING CHART 2

## Test the Transmitter—T150

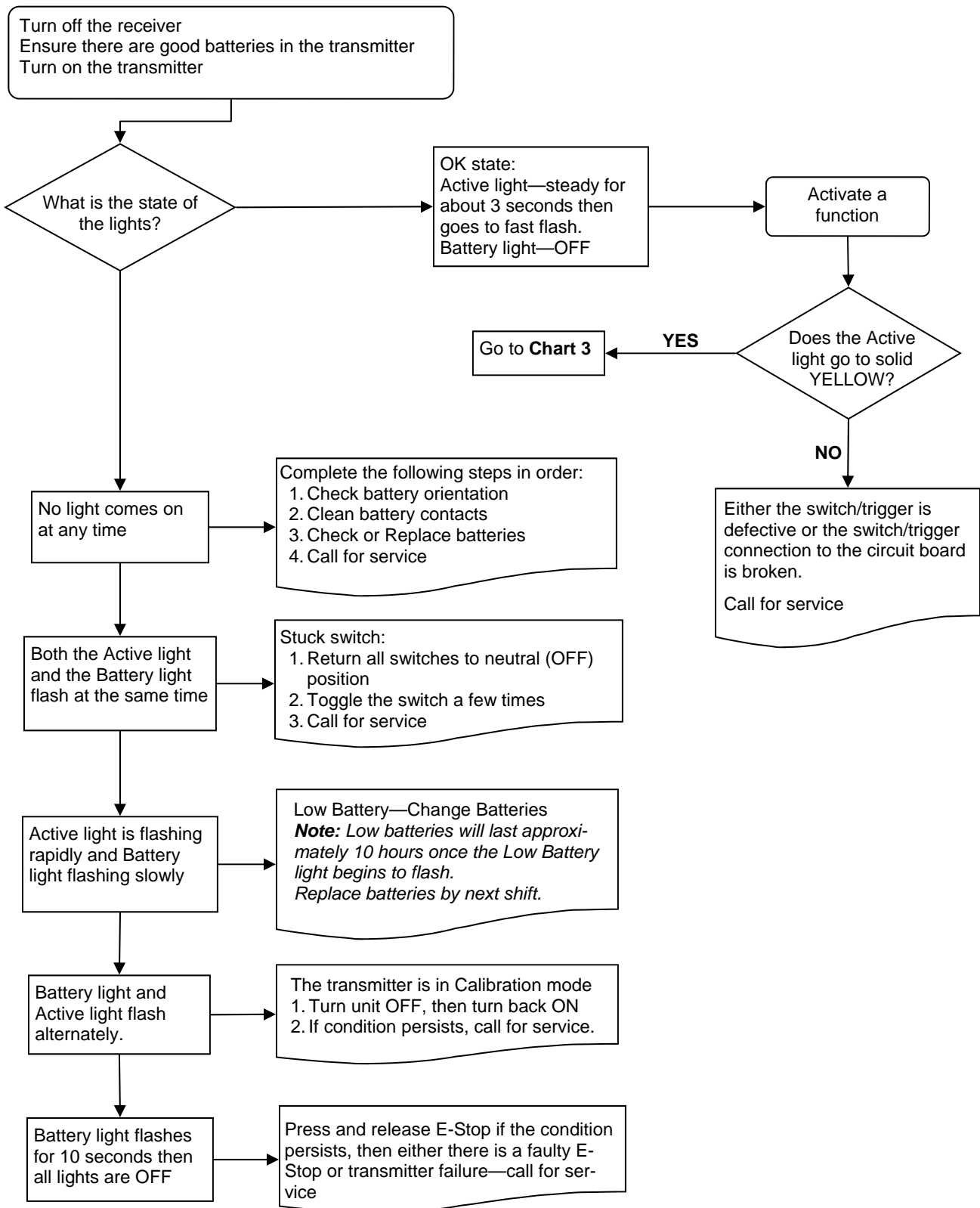

# FM CONTROL TROUBLESHOOTING CHART 3

## Testing the Transmitter / Receiver Communication

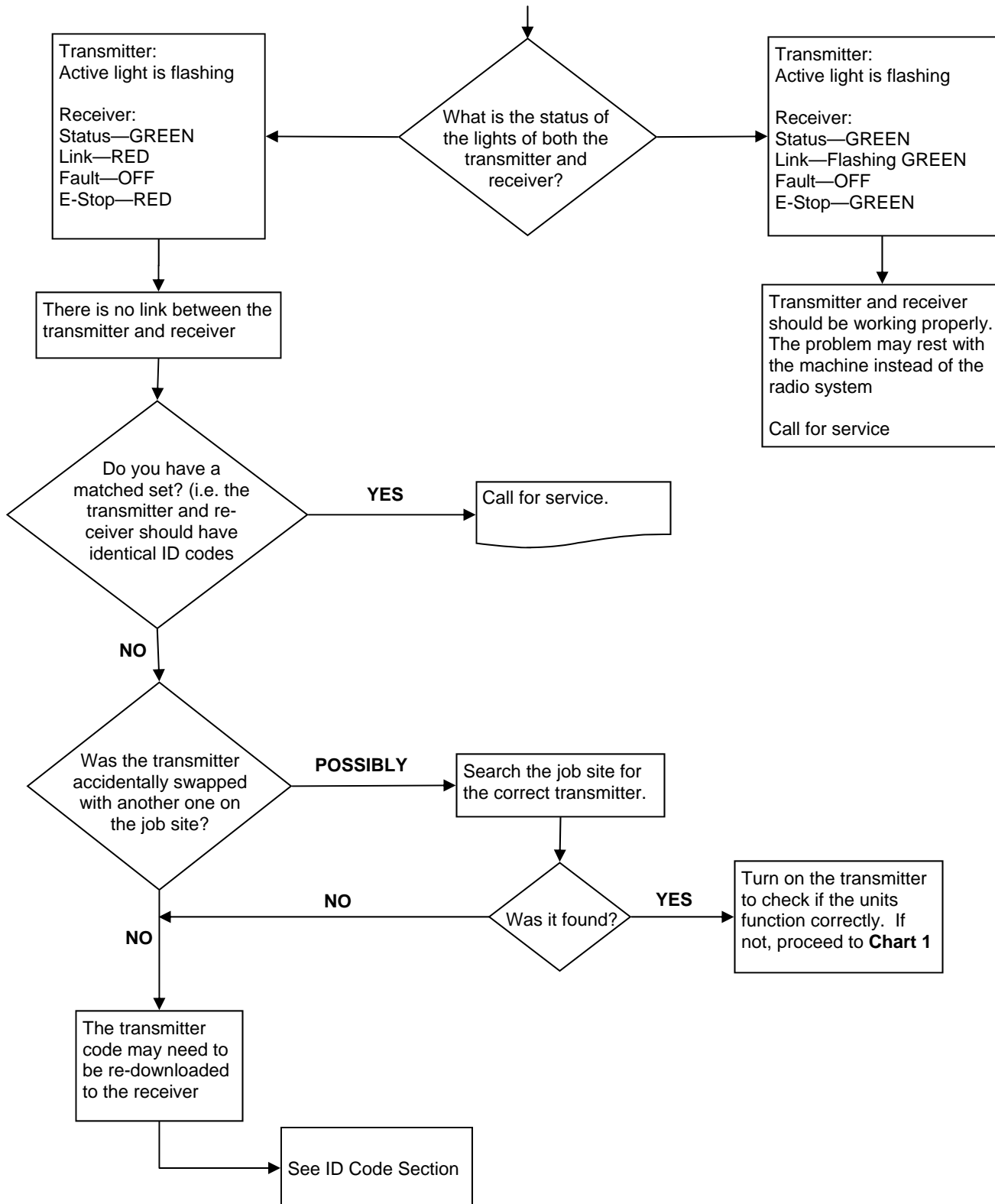

# FM CONTROL ID CODE PROGRAMMING

## Download ID Code (Use in case of Link Test failure)

**!!Caution!!**

**Note:** Before attempting reprogramming with another transmitter, understand that reprogramming the receiver with another transmitter, could result in two receivers on the job site responding to the one transmitter. If the original transmitter was sent in for repair, disconnect the receiver (disconnect connector A) to continue using the machine without remote capability and without fear of inadvertently operating the machine with the other transmitter.

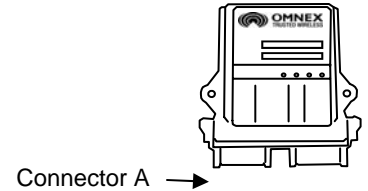

### Reprogramming Tips:

1. Use a pointy instrument to depress the Setup button on the receiver (i.e. a pen) as the button is relatively small
2. Follow each step as laid out in the procedure
3. Never lay the receiver circuit board down on anything metallic (there are contact points on the back which could contact the metal and damage the receiver)

Follow these steps to download the transmitter's unique ID Code into the receiver. This will allow the receiver to establish a radio link with that transmitter.

Refer to the **Light Legend** below for diagram details.

**NOTE:** It is necessary to download the ID Code when replacing either the transmitter or the receiver.

**NOTE:** If the transmitter is connected to the receiver with a Tether Cable, completing **only steps 3 and 5** is necessary (it is not necessary to open the R160 case and press the Setup button).

### 1. Opening the Receiver Case

The cap is held on by two plastic tabs at opposing sides, which can be unlatched as shown using a screwdriver. Once the cap is free, the R160 can slide open.

Use a small slotted screwdriver to press the Side Tabs inward.

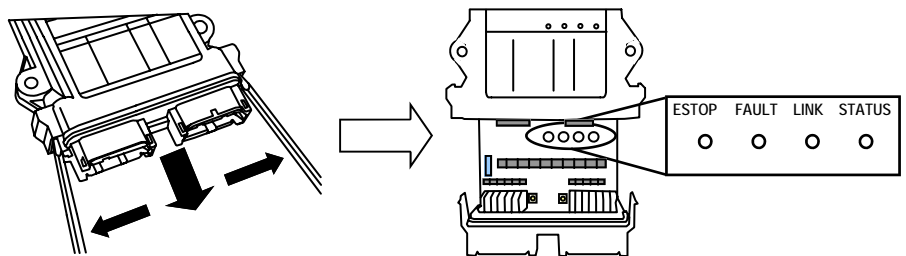

### 2. Prepare Transmitter, Power Receiver

A. Press [POWER] OFF

B. Supply power to the receiver

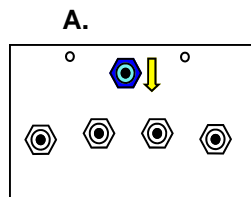

**B.**

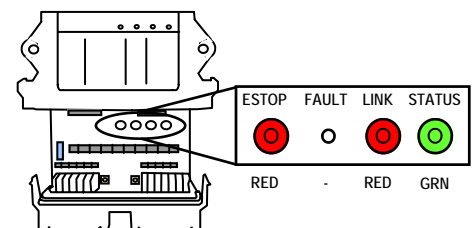

Light Legend	Solid	Slow Flash	Fast Flash	Red Light	Green Light	Yellow Light
--------------	-------	------------	------------	-----------	-------------	--------------

# FM CONTROL ID CODE PROGRAMMING (CONT.)

### 3. Power Transmitter into Configuration Mode

- A. Press & hold [BOOM] switch in the UP position
- B. Press & release [POWER] switch in the OFF position
- C. Release [BOOM] switch

The ACTIVE LED will flash once per second.

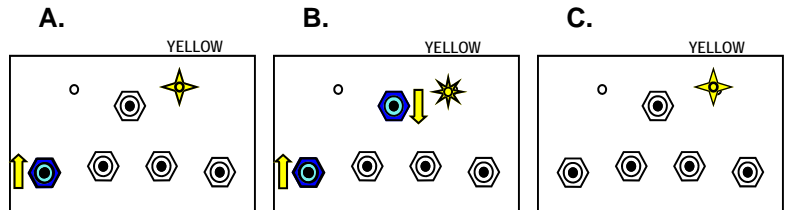

### 4. Put Receiver into Setup

- A. Press & hold [Setup] button until (Status) light goes from slow flash to fast flash
- B. Release [Setup] button. (Status) light goes to solid GREEN, (Link) light turns off

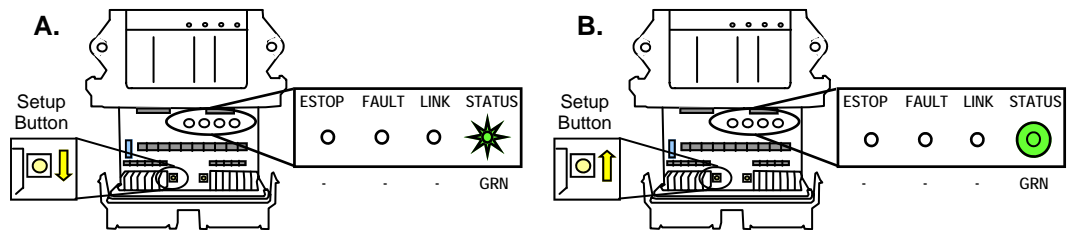

**NOTE:** If left idle in Setup Mode for over 30 seconds, the receiver will time out. The (Link) light and (Status) light will flash RED rapidly. To return to Setup Mode, repeat step 4.

### 5. Download ID Code

- A. Press & release [BOOM] switch in the UP position
- B. The R160 (Link) light goes to GREEN. Once complete, (Link) light goes to RED as the transmitter turns off

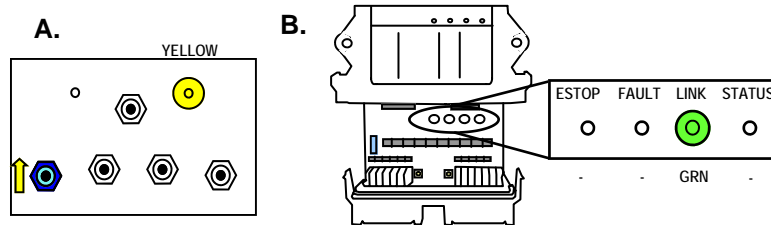

**NOTE:** When replacing the receiver cover, ensure the cover snaps completely into place to create a weather proof seal around the base of the receiver.

Light Legend	Solid	Slow Flash	Fast Flash	Red Light	Green Light	Yellow Light

# 4004EH-20FT LOAD CHART

## P/N: 404240011

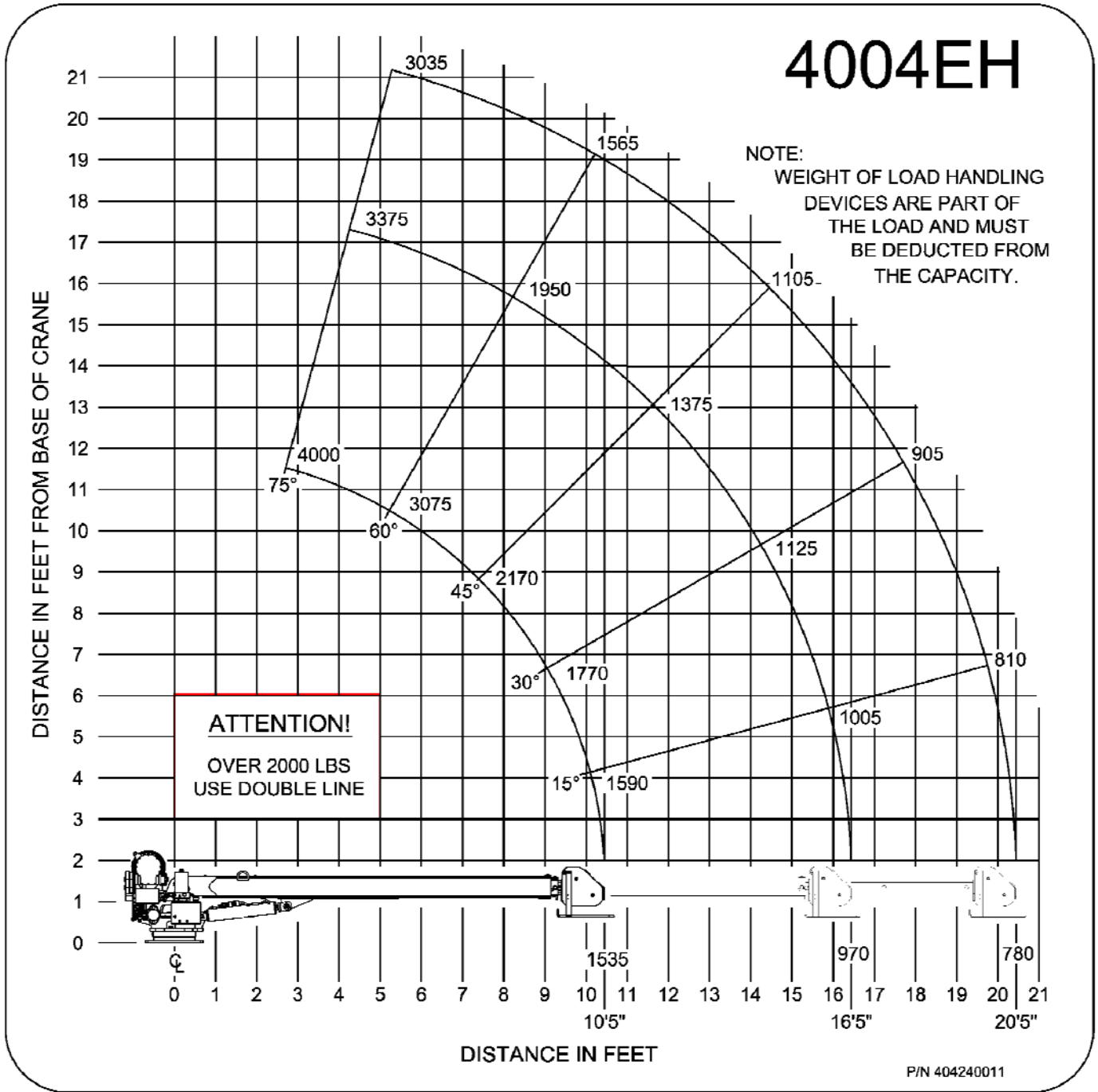

# ***NOTES***



# CRANE PREVENTATIVE MAINTENANCE

## **PAINT FINISH PREVENTIVE MAINTENANCE INSTRUCTIONS**

The paint finish on Auto Crane products can become damaged during normal use when chipped, scratched, exposed to harsh chemicals, cleaned with high pressure washers, etc. During periods when the truck is exposed to salt or other corrosive chemicals, Auto Crane products should be washed weekly. The paint finish should be inspected when washed or at least monthly. Any exposed bare metal or visible rust should be repaired immediately. Damaged paint on cranes should be repaired by:

1. Sanding the damaged areas to bare metal.
2. Solvent cleaning the sanded areas to remove sanding residue. Wipe dry with a clean cloth to remove any remaining residue.
3. Priming the sanded areas to a minimum of a 2 mil dry film thickness per the primer manufacturer's instructions. The primer must be compatible with Sherwin Williams' E2W932 epoxy primer.
4. Applying a 2 mil dry film thickness top coat paint per the manufacturer's instructions within 24 hours of applying the primer. The top coat paint must be compatible with Sherwin Williams' E2W932 epoxy primer and Sherwin Williams' Genesis polyurethane top coat paint. The final primer and top coat should have approximately a 4 mil dry film thickness.



P.O. Box 580697 \* Tulsa, OK 74158-0697  
4707 N. Mingo Rd. \* Phone (918) 836-0463

## LIMITED WARRANTY 2 YEAR PARTS AND LABOR

Auto Crane will warranty to the consumer for a period of (2) years parts and labor from the date of purchase. Each new Auto Crane unit they sell will be free under normal use and service from defects in material and workmanship. Date of purchase will be honored as the date indicated on the Bill of Sale, which must accompany the Warranty Registration and be on file with Auto Crane. Absent a valid Warranty Registration and appropriate documentation, the original date of manufacture, as indicated by the serial number on the product, will be used to determine the effective date of the 2 year warranty.

The obligation of Auto Crane under this warranty is limited to the replacement or repair of parts that appear to the manufacturer after review and/or inspection to be defective and paid flat rate labor for replacing defective parts. This warranty does not obligate Auto Crane to bear the travel time charges in connection with the replacement or repair of defective parts. Responsibility for customer's claims arising from misapplication, abuse, misuse or alteration of equipment or parts lies with the distributor or user and no warranty obligation is assumed in these circumstances by Auto Crane.

Auto Crane will in no event be liable for any consequential damages or contingent liabilities arising out of the failure of any Auto Crane Product or parts to operate properly.

Auto Crane makes no warranty in respect to component accessories, it being subject to the warranties of their respective manufacturers.

If field service, at the request of the distributor, is rendered and fault is found not to be with Auto Crane's product, the distributor shall pay the time and expense of the field representative.

Claims for service labor or other expenses that have incurred by the buyer without approval or authorization or Auto Crane will not be accepted.

When applying for warranty, claims may be handled by contacting your nearest authorized Auto Crane Distributor. All claims are to be filed in writing on an Auto Crane Warranty Claim Form.

**AUTO CRANE COMPANY IS UNDER NO OLIGATION TO EXTEND THIS WARRANTY TO ANY CUSTOMER FOR WHICH AN AUTO CRANE DELIVERY REPORT FORM HAS NOT BEEN COMPLETED AND ON FILE WITH AUTO CRANE COMPANY**



P.O. Box 580697 \* Tulsa, OK 74158-0697  
4707 N. Mingo Rd. \* Phone (918) 438-2760

## LIMITED WARRANTY 1 YEAR PURCHASED REPLACEMENT PARTS

Auto Crane will warranty to the consumer for a period of (1) year from the date that a new Auto Crane replacement part was purchased from an authorized Auto Crane distributor. Each new Auto Crane part they sell will be free under normal use and service from defects in material and workmanship. Date of purchase will be honored as the date indicated on the Bill of Sale to the consumer.

The obligation of Auto Crane under this warranty does not apply to parts replaced under the limited warranty for a new Auto Crane product. The warranty for parts replaced under the limited warranty of a new Auto Crane product expires when the warranty for that product expires.

The obligation of Auto Crane under this warranty is limited to the replacement or repair of purchased replacement parts that appear to the manufacturer to be defective after review of documentation (Auto Crane Warranty Claim Form, photos, data, etc.) provided by the Auto Crane distributor and/or inspection of parts returned to Auto Crane. This warranty does not obligate Auto Crane to bear labor costs to replace the defective parts or travel time charges in connection with the replacement or repair of defective parts. Responsibility for customer's claims arising from misapplication, abuse, misuse or alteration of equipment or parts lies with the distributor or user and no warranty obligation is assumed in these circumstances by Auto Crane.

Auto Crane will in no event be liable for any consequential damages or contingent liabilities arising out of the failure of any Auto Crane product or parts to operate properly.

Auto Crane makes no warranty in respect to parts for component accessories, it being subject to the warranties of their respective manufacturers.

If field service, at the request of the distributor, is rendered and fault is found not to be with Auto Crane's product, the distributor shall pay the time and expense of the field representative.

Claims for service labor or other expenses that have incurred by the buyer without approval or authorization or Auto Crane will not be accepted.

When applying for warranty, claims may be handled by contacting your nearest authorized Auto Crane **Distributor**. **All claims are to be filed in writing on an Auto Crane Warranty Claim Form.**