



3203H OWNERS MANUAL

Manual No. 999954

Rev. 9/2/2003

Serial No. _____

Mailing Address:
P.O. Box 580697
Tulsa, OK 74158-0697
Physical Address:
4707 N. Mingo Rd.
Tulsa, OK 74117-5904

Phone (918) 836-0463
Fax (918) 834-5979
<http://www.autocrane.com>



Auto Crane Warranty Registration

Fax Transmission

To: Warranty Department Fax: (918) 834-5979
 From: _____ Date: _____
 Re: Product Registration Pages: _____

End User Information: (Required for Warranty Activation)

Name: _____ Phone: _____
 Address: _____
 City: _____ State: _____ Zip: _____
 Contact: _____ E-mail Address: _____

Distributor Information: (Required for Warranty Activation)

Name: _____
 Address: _____
 City: _____ State: _____ Zip: _____
 Contact: _____ E-mail Address: _____

Product Information: (Required for Warranty Activation)

Model No.: _____ Serial No.: _____
 Date Product Delivered: _____ Date Processed:* _____
 VIN # _____ * For Auto Crane use only

ONE REGISTRATION FORM PER UNIT (CRANE OR BODY)

Registration form must be mailed or faxed within 15 days of customer installation.

Mail to:
 Warranty Department
 Auto Crane Company
 P.O. Box 581510
 Tulsa, OK 74158-0697

**3203H SERIES
OWNER'S MANUAL – REVISION RECORD**

Revision Date	Section(s) Or Page(s)	Description of Change
09/02/03	Last page	New 2-year warranty policy to replace 1-year warranty policy

WARNINGS

WARNING! Federal law (49 cfr part 571) requires that the Final Stage Manufacturer of a vehicle certify that the vehicle complies with all applicable federal regulations. Any modifications performed on the vehicle prior to the final state are also considered intermediate stage manufacturing and must be certified as to compliance. The installer of this crane and body is considered one of the manufacturers of the vehicle. As such a manufacturer, the installer is responsible for compliance with all applicable federal and state regulations, and is required to certify that the vehicle is in compliance.

WARNING! It is the further responsibility of the installer to comply with the OSHA Truck Crane Stability Requirements as specified by 29 CFR part 1910.180 (C) (1).

WARNING! NEVER OPERATE THE CRANE NEAR ELECTRICAL POWER LINES!

Death or serious injury will result from boom, line, or load contacting electric lines. Do not use crane within 10 feet (3.05m) of electric power lines carrying up to 50,000 volts. One foot additional clearance is required for every additional 30,000 volts or less. **SEE DANGER DECAL (P/N 040529)** in this Owner's Manual.

WARNING! NEVER.....

- ◆ **EXCEED** load chart capacities (centerline of rotation to hoist hook).
- ◆ Un-reel last 5 wraps of cable from drum!
- ◆ Wrap cable around load!
- ◆ Attempt to lift or drag a load from the side! The boom can fail far below its rated capacity.
- ◆ Weld, modify, or use unauthorized components on any Auto Crane unit! This will void any warranty or liability. Also failure of the crane may result.
- ◆ Place a chain link on the tip of the hook and try to lift a load!
- ◆ Use a sling bar or anything larger than the hook throat that could prevent the hook latch from closing, thus negating the safety feature!
- ◆ Hold on any pendant Select Switch that will cause unsafe operating conditions!

WARNING! In using a hook with latch, **ALWAYS** make sure that the hook throat is closed before lifting a load! Proper attention and common sense applied to the use of the hoist hook and various slings will prevent possible damage to material being hoisted and may prevent injury to personnel.

WARNING! Failure to correctly plumb and wire crane can cause inadvertent operation and damage to crane and/or personnel!

WARNING! Auto Crane Company remote controlled cranes are not designed or intended to be used for any applications involving the lifting or moving of personnel.

WARNING! ALWAYS operate the crane in compliance with the load capacity chart. **DO NOT USE** the overload shutdown device to determine maximum rated loads, if the crane is equipped with this type of device.

READ THIS PAGE

3203H SERIES - OWNER'S MANUAL
TABLE OF CONTENTS

	PAGE
1 INTRODUCTION	1-1.0.0
2 OPERATING PRACTICES & WARNINGS	1-2.0.0
3 OPERATION OF UNIT / OUTRIGGERS	1-3.0.0
4 QUALIFICATIONS FOR OPERATORS	1-4.0.0
5 INSPECTION, TESTING, & MAINTENANCE	1-5.0.0
6 LIFE OF WIRE LINE / WIRE LINE LUBRICATION	1-6.0.0
7 SAFETY DECAL SECTION	1-7.0.0
8 LUBRICATION & MAINTENANCE SCHEDULE	1-8.0.0
9 MOUNTING & INSTALLATION	2-1.0.0
10 GENERAL ASSEMBLY	3-1.0.0
11 2-BLOCK ASSEMBLY	3-2.0.0
12 HOIST ACTUATOR ASSEMBLY	3-3.0.0
13 TURNER ASSEMBLY	3-4.0.0
14 AUTOMATIC SAFETY BRAKE ASSEMBLY	3-5.0.0
15 TRAVELING BLOCK ASSEMBLY	3-6.0.0
16 GENERAL DIMENSIONS	4-1.0.0
17 ELECTRICAL SECTION	6-1.0.0
18 HYDRAULIC SECTION	7-1.0.0
19 LOAD CHART	9-1.0.0
20 WARRANTY	LAST PAGE

INTRODUCTION

3203H SERIES

Auto Crane products are designed to provide many years of safe, trouble-free, dependable service when properly used and maintained.

To assist you in obtaining the best service from your crane and to avoid untimely crane and/or vehicle failure, this manual provides the following operating and service instructions. It is **specifically recommended** that all operating and service personnel consider this manual as mandatory material for reading and study before operating or servicing Auto Crane products. It is **highly recommended** that crane owners, equipment managers and supervisors also read this manual.

Auto Crane has incorporated several safety features in the **3203H Series** cranes for your protection. The choice of materials and the design of the electrical system minimizes weight and lengthens durability. The hydraulic components meet or exceed a **3.5:1 safety factor**. Holding valves prevent the load from dropping if a hose should fail. The hydraulic manifold has a **10 micron strainer with relief** at the inlet.

For your convenience the overall dimensions of the **3203H Series** crane are on the General Dimension Drawing. Maximum turning radius is shown at the outside edge of the back cover.

Remember, the crane adds weight to the vehicle. Adding weight may change the driving and riding characteristics of the vehicle unless the appropriate overload spring(s) are installed on the truck. The payload of the vehicle is reduced by the weight of the crane. The operator should exercise care when loading the vehicle. Distributing the payload on the vehicle evenly will greatly improve the driving and riding characteristics of the vehicle. **A minimum G.V.W. of 8,000 lbs. with two rear jacklegs (or outriggers) is recommended for mounting the 3203H crane.**

The **3203H** crane is attached directly to your truck hydraulic power supply. The performance of your new crane depends on the truck hydraulic system. The system should supply **5 gpm at 2200 psig**. Although this unit is fully proportional, any **flow above 5.75 gpm will automatically bypass** back to tank. **This process will add heat to the hydraulic system.** For more information please read the hydraulic section of this manual.

Auto Crane Company issues a limited warranty certificate with each unit sold. See last page for warranty policy.

It has always been Auto Crane Company policy to handle all warranty claims we receive as promptly as possible. If a

warranty claim involves discrepant material or workmanship, Auto Crane will take immediate corrective action. It is understandable that Auto Crane company cannot assume responsibility of liability when it is obvious that our products have been abused, mis-used, overloaded or otherwise damaged by inexperienced persons trying to operate the equipment without reading the manual.

Auto Crane will not assume responsibility or liability for any modifications or changes made to unit, or installation of component parts done without authorization.

Auto Crane maintains a strong distributor network and a knowledgeable Customer Service Department. In most cases, an equipment problem is solved via phone conversation with our customer service department. The customer service department also has the ability to bring a local distributor, a regional sales manager, or a factory serviceman into the solution of an equipment problem. If, through no fault of Auto crane company, it is necessary to send an experienced factory serviceman on a field service call, the rates stated in the Auto Crane Distributor's Flat Rate Manual will apply.

Auto Crane Company's extensive Research and Development Program allow our customers to use the best equipment on the market. Our Engineering Staff and our knowledgeable sales people, are always available to our customers in solving crane and winch-type application problems. When in doubt, call the Auto Crane factory.

DISTRIBUTOR ASSISTANCE:

Should you require any assistance not given in this manual, we recommend that you consult your nearest Auto Crane Distributor. Our distributors sell authorized parts and have service departments that can solve almost any needed repair.

NOTE: THIS MANUAL SHOULD REMAIN WITH THE CRANE AT ALL TIMES.

This manual does not cover all maintenance, operating, or repair instructions pertinent to all possible situations. If you require additional information, please contact the **Auto Crane Company** at the following telephone number: **(918) 836-0463**. The information contained in the manual is in effect at the time of this printing. Auto Crane Company reserves the right to update this material without notice or obligation.

GENERAL SPECIFICATIONS

3203H

Dimensions

Width: 24 in (.61 m)
23.25 (.59 m)
Height: 27.25 in (.69 m)
31.31 in (.80 m)
Length: 8 ft 6 in (2.59 m) [boom(s) stored]
Weight: 630 lbs (286 kg)
[Add 5 lbs (2.25 kg) for cable length
of 75 feet (23 m)]

Capacity

10,500LBS. (1.5 TON/M)

[ft lbs = horizontal distance from centerline of rotation to free hanging weight (feet) x amount of weight (pounds)]

LIFTING CAPACITIES			
ft	lbs	ft	lbs
3	3,200	10	1,050
4	2,625	11	955
5	2,100	12	875
6	1,750	13	808
7	1,500	14	750
8	1,315	15	700
9	1,166		

Reach

Main boom reaches 7 ft
Power boom will extend to 11 ft
Manual boom will extend to 15 ft

Cable

62 ft (18.9 m) of 7/32" diameter aircraft quality
single line breaking strength of 5,600 lbs (2,540 kg).

Chassis Requirements

8,000 lbs (3,629 kg) GVWR minimum

Hydraulic System

Pressure: 2200 psi (15,173 kPa) relief setting
Flow: 5 gpm (19 lpm)
Filtration: High pressure 10 micron in manifold
Oil type: 10w Hydraulic Oil
[Mobile DTE 13, Sun 2015,
Pennzbell AWX, Dextron II]
Hoist Motor: 2.2 cid geroter
Rotation Motor: 11.3 cid geroter

Movement Speeds: (Proportional Maximum)

Hoist: 34 fpm single line (no load)
31 fpm single line (1000 lbs)
Boom Up: 7 sec
Boom Dn: 6 sec
Extend out: 9 sec
Extend in: 7 sec
Rotation: 23 sec / revolution

Electrical System Requirements

Control voltage: 12 volt DC

--- IMPORTANT ---

OPERATING PRACTICES & WARNINGS

1. Make certain the vehicle meets minimum chassis requirements. (These requirements do not guarantee unit stability)
2. Make certain the crane is installed per factory specifications. Contact your local Distributor or the Auto Crane factory if any questions arise.
3. Keep the vehicle in as level a position as possible while loading or unloading.
4. **ALWAYS** set the vehicle emergency brake before beginning crane operations.
5. **ALWAYS** use outriggers from vehicle to the ground during crane operation. Make sure they are firmly positioned on solid footings.
6. All load ratings are based on crane capacity, **NOT** truck/crane stability.
7. Keep objects and personnel clear of crane path during operation.
8. Keep hoist cable pulled tight at all times.
9. **REMEMBER**, in lifting a heavy load, the weight can create enough tipping momentum to overturn the vehicle.
10. **ALWAYS** keep load as close to ground as possible.
11. Oil gears as required.
12. Periodic adjustment of hoist worm brake may be required (see automatic safety brake drawing in this manual).
13. Hydraulic hoses need to be inspected frequently for signs of deterioration, and be replaced as required.
14. The hoist hook is an important item that an operator should consider and use properly. It should be checked on a daily basis for distortion or cracks.
15. **ALWAYS** store outriggers before road travel.
16. **WARNING! NEVER OPERATE THE CRANE NEAR ELECTRICAL POWER LINES!** Death or serious injury will result from boom, line, or load contacting electric lines. Do not use crane within 10 feet (3.05m) of electric power lines carrying up to 50,000 volts. One foot additional clearance is required for every additional 30,000 volts or less.
17. **WARNING! NEVER EXCEED** load chart capacities (centerline of rotation to hoist hook).
18. **WARNING! NEVER** un-reel last 5 wraps of cable from drum!
19. **WARNING! NEVER** wrap cable around load!
20. **WARNING! NEVER** attempt to lift or drag a load from the side! The boom can fail far below its rated capacity.
21. **WARNING! NEVER** weld, modify, or use unauthorized components on any Auto Crane unit! This will void any warranty or liability. Also failure of the crane may result.
22. **WARNING! NEVER** place a chain link on the tip of the hook and try to lift a load!
23. **WARNING! NEVER** use a sling bar or anything larger than the hook throat that could prevent the hook latch from closing, thus negating the safety feature!
24. **WARNING!** In using a hook with latch, **ALWAYS** insure that the hook throat is closed before lifting a load! Proper attention and common sense applied to the use of the hoist hook and various slings will prevent possible damage to material being hoisted and may prevent injury to personnel.
25. **WARNING! NEVER** hold any pendant Select Switch on that will cause unsafe operating conditions!

WARNING!

Auto Crane Company remote controlled, stiff boom cranes are not designed or intended to be used for any applications involving the lifting or moving of personnel.

--- IMPORTANT --- OPERATION OF UNIT

1. Make sure this manual has been thoroughly read by all crane operating personnel and supervisors.
2. A routine inspection of the crane should be mandatory before each operating day. Any defects should be corrected immediately.
3. At a job site the vehicle should be positioned so that the crane can adequately reach the load within the rated capacity (centerline of rotation to hoist hook).
4. Keep the vehicle as level as possible during operation.
5. For electric cranes, **engage emergency brake** and leave ignition on with transmission in neutral (or in park for automatic transmissions). Activate any crane power switches. For Auto Crane units requiring battery and hydraulic operation, **engage emergency brake**, place gear selector in neutral, press clutch, activate PTO, release clutch and after hydraulic fluid is warm, set throttle control to proper engine speed.
6. Always use outriggers from the truck to the ground. Be sure these are firm and adequately positioned. When rotating, **keep load as low to the ground as possible**.
7. Remove pendant control from cab or storage area. On smaller units, plug pendant into receptacle on crane. On larger units, remove pendant control from guard and unwrap cable from boom. Do not operate crane until cable is unwound completely. On all cranes, detach hook from dead man. Crane is now ready for operation.
8. Always boom up before rotating so the boom will clear the required boom support.
9. When extending the boom, always maintain clearance between the boom crown and the traveling block or hoist hook.
10. Always observe safe and practical operation to avoid possible accidents. Refer to Safety Tips and Precautions.
11. After completing lifting operations, return the boom to stowed position on the boom support. Avoid unneeded pressure on the boom support.
12. Store pendant control on proper location (in cab or on crane).
13. Return outriggers to stowed position. Make sure they are pinned in place or jacklegs are returned to compartment.
14. Check work area for any tools or equipment not stored.
15. Release throttle control, depress clutch and disengage PTO. Deactivate any crane power switches.
16. Report any unusual occurrence during crane operation that may indicate required maintenance or repair.
17. **NEVER** use two cranes to support a load too large for either crane.
18. Spray all electrical equipment with special corrosion resistant coating. This eliminates rust or corrosion due to melting and freezing action of condensation.

OPERATION OF OUTRIGGERS

For hydraulic outriggers:

1. Shift crane/outrigger control valve to "outrigger" position.
2. While operating the outrigger control valves (located on the outrigger cylinders) simultaneously operate the boom-up control switch. This will allow the hydraulic system to build pressure.
3. After outriggers are positioned, return crane/outrigger selector to "crane" position.
4. Crane is now ready to operate.

For manual outriggers:

1. Pull lock pins to release jack leg or drop down outrigger and move to outermost lock position.
2. Make sure lock pins are reinstalled properly.
3. Lower outrigger pad to firm ground and adjust foot to take out slack.
4. Crane is now ready to operate.

QUALIFICATIONS FOR AND CONDUCT OF OPERATORS AND OPERATING PRACTICES

OPERATORS

- 1 Crane operation shall be limited to personnel with the following minimum qualifications:**
 - A. designated persons
 - B. trainees under the direct supervision of a designated person
 - C. maintenance and test personnel (when it is necessary in the performance of their duties)
 - D. inspectors (crane).
- 2 No one other than the personnel specified above shall enter the operating area of a crane with the exception of persons such as oilers, supervisors, and those specified persons authorized by supervisors whose duties require them to do so and then only in the performance of their duties and with the knowledge of the operator or other persons.**

QUALIFICATIONS FOR OPERATORS

- 3 Operators shall be required by the employer to pass a practical operating examination. Qualifications shall be limited to the specific type of equipment for which examined.**
- 4 Operators and operator trainees shall meet the following physical qualifications:**
 - A. Vision of at least 20/30 Snellen in one eye and 20/50 in the other, with or without corrective lenses.
 - B. Ability to distinguish colors, regardless of position, if colors differentiation is required for operation.
 - C. Adequate hearing with or without hearing aid for the specific operation.
- 5 Evidence of physical defects or emotional instability which render a hazard to operator or others, which in the opinion of the examiner could interfere with the operator's performance may be sufficient cause for disqualification. In such cases, specialized clinical or medical judgment and tests may be required.**
- 6 Evidence that the operator is subject to seizures or loss of physical control shall be sufficient reason for disqualification. Specialized medical tests may be required to determine these conditions.**
- 7 Operators and operator trainees should have normal depth perception, coordination, and no tendencies to dizziness or similar undesirable characteristics.**

- 8 In addition to the above listed requirements, the operator shall:**

- A. Demonstrate the ability to comprehend and interpret all labels, operator's manuals, safety codes and other information pertinent to correct crane operations.
- B. Possess knowledge of emergency procedures and implementation of same.
- C. Demonstrate to the employer the ability to operate the specific type of equipment.
- D. Be familiar with the applicable safety regulations.
- E. Understand responsibility for maintenance requirements of crane.
- F. Be thoroughly familiar with the crane and its control functions.
- G. Understand the operating procedures as outlined by the manufacturer.

CONDUCT OF OPERATORS

- 9 The operator shall not engage in any practice which will divert his attention while actually operating the crane.**
- 10 Each operator shall be responsible for those operations under the operator's direct control. Whenever there is any doubt as to safety, the operator shall consult with the supervisor before handling the loads.**
- 11 The operator should not leave a suspended load unattended unless specific precautions have been instituted and are in place.**
- 12 If there is a warning sign on the switch or engine starting controls, the operator shall not close the switch or start the engine until the warning sign has been removed by the appointed person.**
- 13 Before closing the switch or starting the engine, the operator shall see that all controls are in the "OFF" or neutral position and all personnel are in the clear.**
- 14 If power fails during operation, the operator shall:**
 - A. move power controls to the "OFF" or neutral position.
 - B. land the suspended load and boom, if practical.
- 15 The operator shall be familiar with the equipment and its proper care. If adjustments or repairs are necessary, the operator shall report the same**

QUALIFICATIONS FOR AND CONDUCT OF OPERATORS AND OPERATING PRACTICES

promptly to the appointed person, and shall also notify the next operator.

16 All controls shall be tested by the operator at the start of each shift. If any controls do not operate properly, they shall be adjusted or repaired before operations are begun.

17 Stabilizers shall be visible to the operator while extending or setting unless operator is assisted by a signal person.

OPERATING PRACTICES

HANDLING THE LOAD

18 Size of load

- A. No crane shall be loaded beyond the rated load except for test purposes.
- B. The load to be lifted is to be within the rated load of the crane and its existing configuration.
- C. When loads which are not accurately known are to be lifted, the person responsible for the job shall ascertain that the weight of the load does not exceed the crane rated load at the radius at which the load is to be lifted.

19 Attaching the load

- A. The load shall be attached to the hook by means of slings or other devices of sufficient capacity.
- B. Hoist rope shall not be wrapped around the load.

20 Moving the load

- A. The operator shall determine that:
- B. The crane is level and, where necessary, the vehicle/carrier is blocked properly.
- C. The load is well secured and balanced in the sling or lifting device before it is lifted more than a few inches.
- D. Means are provided to hold the vehicle stationary while operating the crane.
- E. Before starting to lift, the hook shall be brought over the load in such a manner as to minimize swinging.
- F. During lifting care shall be taken that:

1. **there is no sudden acceleration or deceleration of the moving load.**

2. **load, boom or other parts of the crane do not contact any obstruction.**

- G. Cranes shall not be used for dragging loads sideways.
- H. This standard recognizes that articulating boom cranes are designed and intended for handling materials. They do not meet personnel lift or elevator requirements. Therefore, no lifting, lowering, swinging or traveling shall be done while a person is on the hook or load. Hook attached suspended work platforms (baskets) shall not be used with cranes covered by this standard. Work platforms attached to the boom must be approved by crane manufacturer.
- I. The operator should avoid carrying loads over people.
- J. When the crane is so equipped, the stabilizers shall be fully extended and set. Blocking under stabilizers shall meet the requirements as follows:
 1. **strong enough to prevent crushing.**
 2. **of such thickness, width and length as to completely support the stabilizer pad.**
- K. Firm footing under all tires, or individual stabilizer pads should be level. Where such a footing is not otherwise supplied, it should be provided by timbers, cribbing, or other structural members to distribute the load so as to not exceed allowable bearing capacity or the underlying material.
- L. In transit, the boom shall be carried in stowed position.
- M. When rotating the crane, sudden starts and stops shall be avoided. rotational speed shall be such that the load does not swing out beyond the radius at which it can be controlled.
- N. The crane shall not be transported with a load on the hook unless recommended by the manufacturer.
- O. No person should be permitted to stand or pass under a suspended load.

21 Stowing procedure. Follow the manufacturer's procedure and sequence when stowing and un-stowing the crane.

QUALIFICATIONS FOR AND CONDUCT OF OPERATORS AND OPERATING PRACTICES

MISCELLANEOUS

OPERATING NEAR ELECTRICAL POWER LINES

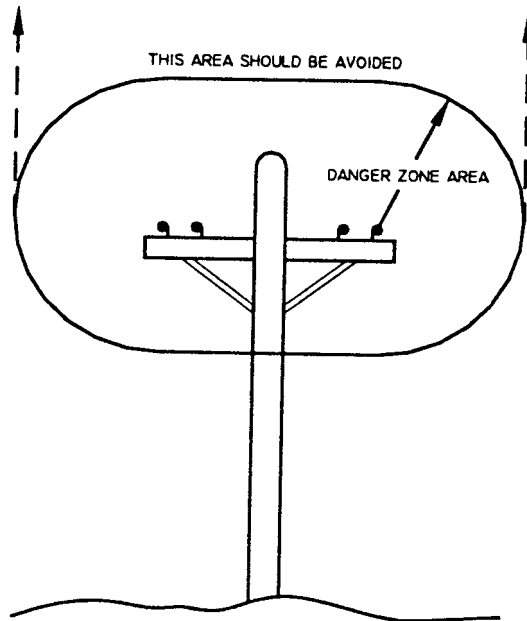

22 Cranes shall be operated so that no part of the crane or load enters into the danger zone shown above.

EXCEPTIONS

- A. The danger zone may be entered after confirmation by an appointed person that the electrical distribution and transmission lines have been de-energized and visibly grounded at the point of work; or
- B. The danger zone may be entered if insulating barriers (not a part of nor an attachment to the crane) have been erected to prevent physical contact with the lines.

23 For lines rated 50 kV or below, minimum clearance between the lines and any part of the crane or load (including handling appendages) shall be 10 ft. (3m). For higher voltages, see Table 1.

24 Caution shall be exercised when working near overhead lines, because they can move horizontally or vertically due to wind, moving the danger zone to new positions.

25 In transit with no load and boom lowered the clearance shall be specified in Table 1.

26 A qualified signperson shall be assigned to observe the clearance and give warning before approaching the above limits.

- A. Any overhead wire shall be considered to be an energized line unless and until the person owning such line or the electrical utility authorities verify that it is not an energized line.
- B. Exceptions to this procedure, if approved by the administrative or regulatory authority if the alternate procedure provides equivalent protection and set forth in writing.
- C. Durable signs shall be installed at the operator's station and on the outside of the crane, warning that electrocution or serious bodily injury may occur unless a minimum clearance of 10 ft. (3.0m) between the crane or the load being handled and energized power lines. Greater clearances are required because of higher voltage as stated above. These signs shall be revised but not removed when local jurisdiction requires greater clearances.

TABLE 1

normal voltage, kV (phase to phase)		minimum required clearance	
		ft	(m)
<u>when operating near high voltage power lines</u>			
over	to 50	10	(3.05)
over	50 to 200	15	(4.6)
over	200 to 350	20	(6.1)
over	350 to 500	25	(7.62)
over	500 to 750	35	(10.67)
over	750 to 1000	45	(13.72)
<u>while in transit with no load and boom lowered</u>			
over	to 0.75	4	(1.22)
over	0.75 to 50	6	(1.83)
over	50 to 345	10	(3.83)
over	345 to 750	16	(4.87)
over	750 to 1000	20	(6.1)

INSPECTION, TESTING AND MAINTENANCE

GENERAL

INSPECTION CLASSIFICATION

- 1 Initial inspection. Prior to initial use, all new, altered, modified or extensively repaired cranes shall be inspected by a designated person to insure compliance with provisions of this standard.**
- 2 Regular inspection. Inspection procedure for cranes in regular service is divided into two general classifications based upon the intervals at which inspection should be performed. The intervals in turn are dependent upon the nature of the components of the crane and the degree of their exposure to wear, deterioration, or malfunction. The two general classifications are herein designated as "frequent" and "periodic" with respective intervals between inspections as defined below.**
 - A. frequent inspection - daily to monthly intervals
 - B. periodic inspection - one to twelve intervals, or as specifically recommended by the manufacturer

FREQUENT INSPECTION

- 3 Inspection shall be performed by designated personnel.**
 - A. control mechanisms for maladjustment interfering with proper operation - daily, when used
 - B. control mechanisms for excessive wear of components and contamination by lubricants or other foreign matter
 - C. safety devices for malfunction
 - D. all hydraulic hoses, particularly those which flex in normal operation of crane functions, should be visually inspected once every working day, when used
 - E. hooks and latches for deformation, chemical damage, cracks, and wear. Refer to ANSI/ASME B30.10
 - F. rope reeving for compliance with crane manufacturer's specifications, if optional winch is used
 - G. electrical apparatus for malfunctioning, signs of excessive deterioration, dirt and moisture accumulation

- H. hydraulic system for proper oil level and leaks daily
- I. tires for recommended inflation pressure, cuts and loose wheel nuts
- J. connecting pins and locking device for wear and damage

PERIODIC INSPECTION

- 4 Deformed, cracked or corroded members in the crane structure and carrier.**
- 5 Loose bolts, particularly mounting bolts.**
- 6 Cracked or worn sheaves and drums.**
- 7 Worn, cracked, or distorted parts such as pins, bearings, shafts, gears, rollers and devices.**
- 8 Excessive wear on brake and clutch system parts and lining.**
- 9 Crane hooks inspected for cracks.**
- 10 Travel steering, braking, and locking devices, for malfunction.**
- 11 Excessively worn or damaged tires.**
- 12 Hydraulic and pneumatic hose, fittings, and tubing inspection.**
 - A. evidence of leakage at the surface of the flexible hose or its junction with metal and coupling
 - B. blistering, or abnormal deformation to the outer covering of the hydraulic or pneumatic hose
 - C. leakage at threaded or clamped joints that cannot be eliminated by normal tightening or recommended procedures
 - D. evidence or excessive abrasion or scrubbing on the outer surface of a hose, rigid tube, or fitting. Means shall be taken to eliminate the interference of elements in contact or otherwise protect the components

INSPECTION, TESTING AND MAINTENANCE

GENERAL

13 Hydraulic and pneumatic pumps and motors inspection.

- A. loose bolts or fasteners
- B. leaks at joints between sections
- C. shaft seal leaks
- D. unusual noises or vibrations
- E. loss of operating speed
- F. excessive heating of the fluid
- G. loss of pressure

14 Hydraulic and pneumatic valves inspection.

- A. cracks in valve housing
- B. improper return of spool to neutral position
- C. leaks at spools or joints
- D. sticking spools
- E. failure of relief valves to attain or maintain correct pressure setting
- F. relief valve pressure shall be checked as specified by the manufacturers

15 Hydraulic and pneumatic cylinders inspection.

- A. drifting caused by fluid leaking across piston
- B. rod seals leaking
- C. leaks at welding joints
- D. scored, nicked, or dented cylinder rods
- E. damaged case (barrel)
- F. loose or deformed rod eyes or connecting joints

16 Hydraulic filters. Evidence of rubber particles on the filter elements may indicate hose, "O" ring, or other rubber component deterioration. Metal chips or pieces on the filter may denote failure in pumps, motors, or cylinders. Further checking will be necessary to determine origin of the problem before corrective action can be taken.

17 Labels are to be in place and legible.

CRANES NOT IN REGULAR USE

18 A crane which has been idle for a period of over one month or more, but not less than six months, shall be given an inspection conforming with the initial-regular- frequent inspections.

19 A crane which has been idle for a period of over six months shall be given a complete inspection conforming with the initial-regular-frequent inspection requirements.

INSPECTION RECORDS

20 Dated records for periodic inspection should be made on critical items such as brakes, crane hooks, rope, hydraulic and pneumatic cylinders, and hydraulic and pneumatic relief pressure valves. Records should be kept available to an appointed person.

OPERATIONAL TESTS

21 Prior to initial use, all new, altered, modified, or extensively repaired cranes shall be tested for compliance with the operational requirements of this section, including functions such as the following:

- A. load lifting and lowering mechanisms
- B. boom lifting and lowering mechanisms
- C. boom extension and retraction mechanisms
- D. swing mechanisms
- E. safety devices
- F. operating controls comply with appropriate function labels

Operational crane test results shall be made available to an appointed person.

RATED TEST LOAD

Prior to initial use, altered, modified, or extensively repaired cranes shall be load tested by or under the direction of an appointed person.

INSPECTION, TESTING AND MAINTENANCE

GENERAL

22 Test loads shall not exceed 110% of the manufacturer's load ratings.

23 Written reports shall be maintained showing test procedures and confirming the adequacy of repairs.

MAINTENANCE

PREVENTIVE MAINTENANCE

24 Before adjustment and repairs are started on a crane, the following precautions shall be taken as applicable:

- A. crane placed where it will cause the least interference with other equipment or operations
- B. all controls at the "off" position
- C. starting means rendered inoperative
- D. boom lowered to the ground if possible or otherwise secured against dropping
- E. relieve hydraulic oil pressure from all hydraulic circuits before loosening or removing hydraulic components

25 Warning or "OUT OF ORDER" signs shall be placed on the crane controls.

26 After adjustments and repairs have been made, the crane shall not be returned to service until all guards have been reinstalled, trapped air removed from hydraulic system (if required), safety devices reactivated, and maintenance equipment removed.

ADJUSTMENTS AND REPAIRS

27 Any hazardous conditions disclosed by the inspection requirements shall be corrected before operation of crane is resumed, Adjustments and repairs shall be done only by designated personnel.

28 Adjustments shall be maintained to assure correct functioning of components, The following are examples:

- A. functional operating mechanism
- B. safety devices

C. control systems

29 Repairs or replacements shall be provided as needed for operation.

The following are examples:

- A. critical parts of functional operating mechanisms which are cracked, broken, corroded, bent, or excessively worn
- B. critical parts of the crane structure which are cracked, bent, broken, or excessively corroded
- C. crane hooks showing cracks, damage, or corrosion shall be taken out of service. Repairs by welding are not recommended

30 Instructions shall be provided by the manufacturer for the removal of air from hydraulic circuits.

LUBRICATION

All moving parts of the crane, for which lubrication is specified, should be regularly lubricated per the manufacturer's recommendations and procedures.

ROPE INSPECTION

31 Frequent Inspection

- A. All running ropes in service should be visually inspected once each working day. A visual inspection shall consist of observation of all rope which can be in use during the days operations. These visual observations should be considered with discovering gross damage such as listed below, which may be an immediate hazard.

1. **distortion of the rope such as kinking, crushing, un-stranding, birdcaging, main strand displacement, or core protrusion. Loss of rope diameter in a short length or unevenness of outer strands should be replaced**
2. **general corrosion**
3. **broken or cut strands;**
4. **number, distribution and type of visible broken wires. When such damage is**

INSPECTION, TESTING AND MAINTENANCE

GENERAL

discovered, the rope shall either be removed from service or given as inspection.

- B. Care shall be taken when inspecting sections of rapid deterioration such as flange points, crossover points, and repetitive pickup points on drums.

32 Periodic inspection

- A. The inspection frequency shall be determined by a qualified person and shall be based on such factors as:

- 1. expected rope life as determined by experience on the particular installation or similar installations**
- 2. severity of environment**
- 3. percentage of capacity lifts**
- 4. frequency rates of operation**
- 5. exposure to shock loads**

Inspection need not be at equal calendar intervals and should be more frequent as the rope approaches the end of its service life. This inspection shall be made at least annually.

- B. Periodic inspection shall be performed by a designated person. This inspection shall cover the entire length of the rope. Only the surface wires need be inspected. No attempt should be made to open the rope. Any deterioration results in appreciable loss of original strength, such as described below, shall be noted and determination made as to whether use of the rope would constitute a hazard: points listed above reduction of rope diameter below nominal diameter due to loss of core support, internal or external corrosion, or wear of outside wires; severely corroded, cracked, bent, worn or improperly applied connections;
- C. Care shall be taken when inspecting sections subject to rapid deterioration such as the following:

- 1. sections in contact with saddles, equalizer sheaves, or other sheaves where rope travel is limited**

- 2. sections of the rope at or near terminal ends where corroded or broken wires may protrude**

ROPE REPLACEMENT

- 33 No precise rules can be given for determination of the exact time for replacement of rope, since many variable factors are involved.**

Continued use in this respect depends upon good judgement by a designated person in evaluating remaining strength in a used rope after allowance for deterioration disclosed by inspection. Continued rope operation depends upon this remaining strength.

- 34 Conditions such as the following shall be reason for questioning continued use of the rope or increasing the frequency of inspection:**

- A. in running ropes, six randomly distributed broken wires in one lay or three broken wires in one strand in one lay
- B. one outer wire broken at the contact point with the core of the rope structure and protrudes or loops out of the rope structure. Additional inspection of this section is required
- C. wear of one third of the original diameter of the outside individual wire
- D. kinking, crushing, birdcaging, or any other damage resulting in distortion of the rope structure
- E. evidence of any heat damage from any cause
- F. reduction from nominal diameter of more than 1/64 in. (0.4mm) for diameters up to and including 5/16 in. (8 mm), 1/32 in. (0.8 mm) for diameter 3/8 in. (9.5 mm) to and including 1/2 in. (13 mm), 3/64 in. (1.2 mm) for diameter 9/16 in. (14.5 mm) to and including 3/4 in. (19 mm), 1/16 in. (1.6 mm) for diameter 7/8 in. (22 mm) to and including 11/8 in. (29 mm), 3/32 in. (2.4 mm) for diameters 11/4 in. (32 mm) to and including 11/2 in. (38 mm)
- G. In standing ropes, more than two broken wires in one lay in sections beyond end connections or more than one broken wire at an end connection.

INSPECTION, TESTING AND MAINTENANCE

GENERAL

H. Replacement rope shall have a strength rating at least as great as the original rope furnished or recommended by the crane manufacturer. Any deviation from the original size, grade, or construction shall be specified by a rope manufacturer, or a qualified person.

35 Rope not in regular use: all rope which has been idle for a period of a month or more due to shutdown or storage of a crane on which it is installed, shall be given and inspection in accordance with above information before it is placed in service. This inspection shall be for all types of deterioration and shall be performed by a qualified person.

36 Inspection records

- A. frequent inspection- no records required
- B. periodic inspections- in order to establish data as a basis for judging the proper time for replacement, a dated report condition at each periodic inspection should be kept on file. This report shall cover points of deterioration listed above.

ROPE MAINTENANCE

37 Rope should be stored to prevent damage or deterioration.

38 Unreeling or uncoiling of rope shall be done as recommended by the rope manufacturer and with care to avoid kinking or inducing twist.

39 Before cutting a rope, seizing shall be placed on each side of the place where the rope is to be cut to prevent unlaying of the strands. On pre-formed rope, one seizing on each side of the cut is required. On non-preformed ropes of 7/8 in. (22 mm) diameter or smaller, two seizings on each side of the cut are required, and for non-preformed rope 1 in. (25 mm) diameter or larger, three seizings on each side of the cut are required.

40 During installation care should be exercised to avoid dragging of the rope in the dirt or around objects which will scrape, nick crush or induce sharp bends in it.

41 Rope should be maintained in a well-lubricated condition. It is important that lubricant applied as a part of a maintenance program shall be compatible with the original lubricant and to this end the rope manufacturer should be consulted. Lubricant applied shall be the type which does not hinder visual inspection. Those sections of rope which are located over sheaves or otherwise hidden during inspection and maintenance procedures require special attention when lubricating rope. The object of rope lubrication is to reduce internal friction and to prevent corrosion.

42 When an operating rope shows greater wear or well defined localized areas than on the remainder of the rope, rope life can be extended in cases where a section at the worn end, and thus shifting the wear to different areas of the rope.

LIFE OF WIRE LINE

So many variable factors can cause the deterioration of wire line cable that it is not possible to determine a definite life expectancy. Some of these factors are:

- 1. Load being handled.**
- 2. Corrosive conditions.**
- 3. Maintenance of the unit.**
 - A. Keep the sheaves turning freely
 - B. Maintain tension on cable to insure proper spooling
 - C. Avoid kinks in cable
 - D. Avoid abrasive action and contact with sharp corners
- 4. Frequency of use.**

Auto Crane units, up to 2,400 pound ratings, use 3/16 inch diameter galvanized pre-formed 7 x 19 aircraft cable. This cable has a working strength, when new, of 4,200 pounds. It is recommended when 1,200 pound loads are exceeded to use a two part line with a traveling block. This will ensure a 3.5 to 1 safety factor when the cable is new.

Keeping the above factor of safety in mind and knowing the kind of loads that will be handled, the user can determine by inspection of the cable as to when it should be replaced.

Items to look for while inspecting the cables are:

- 1. Broken strands.**
- 2. Kinks and flattened sections.**
- 3. Corrosion and abrasion.**

WIRE LINE LUBRICATION

Lubrication of the wire line serves two important purposes: (1) helps to prevent corrosion; (2) lubricates the cable strands to reduce wear due to flexing and abrasion caused by contact with the sheaves, rollers, and cable on the drum.

PREPARATION:

Remove rust and foreign matter with a wire brush and wipe clean. Be sure cable is dry.

APPLICATION:

Method 1: A light weight motor oil may be used by dipping a brush into the lubricant and applying. In some cases, a rag or piece of sheepskin is dipped in the lubricant and used to swab the lubricant on to the rope.

Method 2: A heavier lubricant such as a grease gun lubricant may be used by applying with hands while wearing leather gloves. (Leather gloves are preferred to canvas because of greater protection and less penetration of the grease)



Safety Decal Section

3203

revision 8/00

ITEM	DESCRIPTION	QTY	FIG
1	DANGER, STAY CLEAR OF BOOM	1	SD-1
2	DANGER, STAY CLEAR OF LOAD	1	SD-2
3	DANGER, SCISSORS POINT	2	SD-3
4	DANGER, ELECTROCUTION HAZARD	2	SD-4
5	DANGER, OPERATION INSTRUCTIONS	2	SD-5
6	DANGER, OPERATOR TRAINING	2	SD-6
7	WARNING, LOAD SENSOR TAMPERING	1	SD-7

AUTO CRANE COMPANY
PO BOX 580697, TULSA, OK 74158-0697
4707 N. MINGO ROAD, TULSA, OK 74117-5904
Phone (918) 836-0463. Fax (918) 834-5979

SAFETY DECAL SECTION

PART NO.: 040517
 DECAL: STAY CLEAR OF BOOM
 FUNCTION: To inform the operator of the hazard of proximity or contact with the crane boom during operation.
 QUANTITY: 2
 PLACEMENT: Both sides of crown
 (see page 1-7.3.0, Item 1)

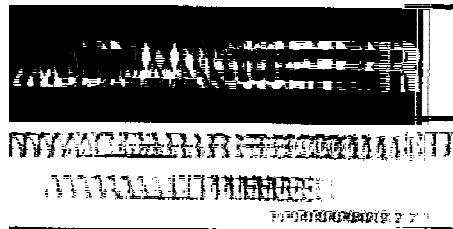

FIG. SD-1.

PART NO.: 040518
 DECAL: STAY CLEAR OF LOAD
 FUNCTION: To inform the operator of the hazard of proximity or contact with the crane load during operation.
 QUANTITY: 2
 PLACEMENT: Both sides of crown plate
 (see page 1-7.3.0, Item 2)

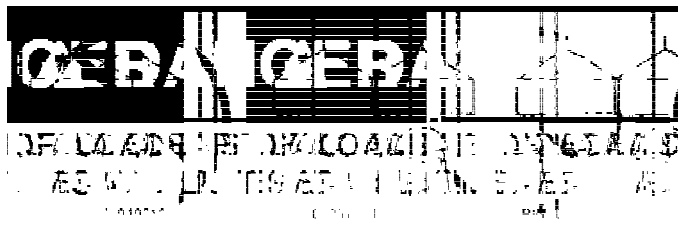

FIG. SD-2.

PART NO.: 040519
 DECAL: SCISSORS POINT
 FUNCTION: To inform the operator of possible danger at scissors point on crane.
 QUANTITY: 1
 PLACEMENT: Both sides of lift cylinder
 (see page 1-7.3.0, Item 3)



FIG. SD-3.

SAFETY DECAL SECTION

PART NO.: 040529 **QUANTITY:** 2
DECAL: ELECTROCUTION HAZARD **PLACEMENT:** Both sides of end of lower boom
FUNCTION: To inform the operator of the hazard involved with contacting electrical power lines with crane boom. (see page 1-7.3.0, Item 16)

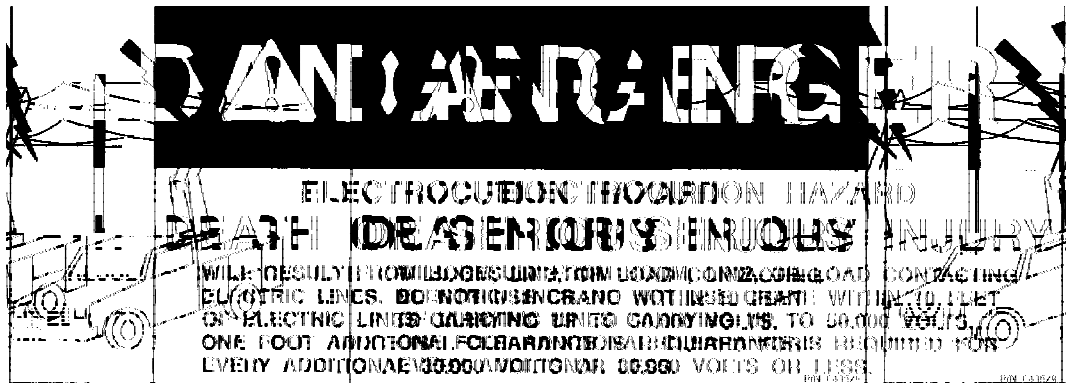

FIG. SD-4.

PART NO.: 040579
DECAL: OPERATION INSTRUCTIONS
FUNCTION: To inform the operator of the proper procedure to follow for safe operation of the crane.
QUANTITY: 1
PLACEMENT: Left Sideplate
T: (see page 1-7.3.0, Item 4)

⚠ DANGER

FAILURE TO OBEY THE FOLLOWING
WILL RESULT IN
DEATH OR SERIOUS INJURY

- Inspect crane and its operation daily.
- For crane stability use only on solid, level surface with outriggers properly extended.
- Crane must be level.
- Operate all controls slowly and smoothly.
- Never operate the crane with personnel under boom or load.
- Keep load under boom tip. Do not side load boom or drag loads. Avoid free swinging loads.
- Keep at least 3 wraps of load line on winch drum.
- For travel, boom and outriggers must be in stowed position.
- The operator must reduce loads to allow for factors such as wind, ground conditions, operating speeds, and the effect of freely suspended loads

P/N 040579-0

FIG. SD-5.

SAFETY DECAL SECTION

PART NO.: 040580
DECAL: OPERATOR TRAINING
FUNCTION: To inform the operator of the need to receive proper training before using the crane.
QUANTITY: 1
PLACEMENT: Left Sideplate
(see page 1-7.3.0, Item 5)

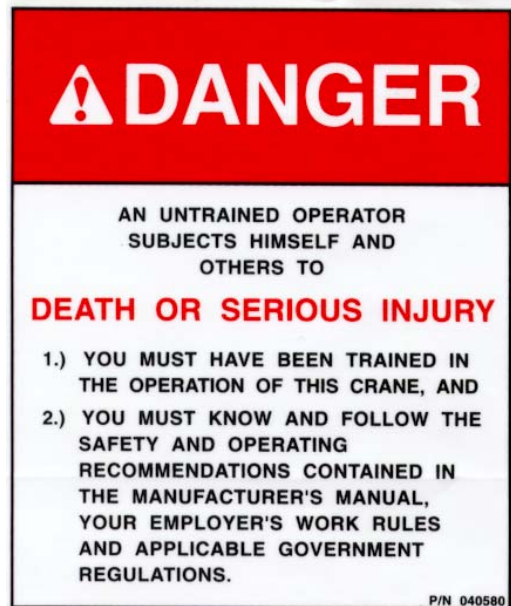

FIG. SD-7.

PART NO.: 040587
DECAL: LOAD SENSOR
FUNCTION: To inform the operator that the load sensor is pre-set and that tampering with the sensor may cause potentially hazardous situation.
QUANTITY: 1
PLACEMENT: On the lift cylinder near the load sensor
(see page 1-7.3.0, Item 6)



FIG. SD-8.

DECAL DRAWING

3203H SERIES

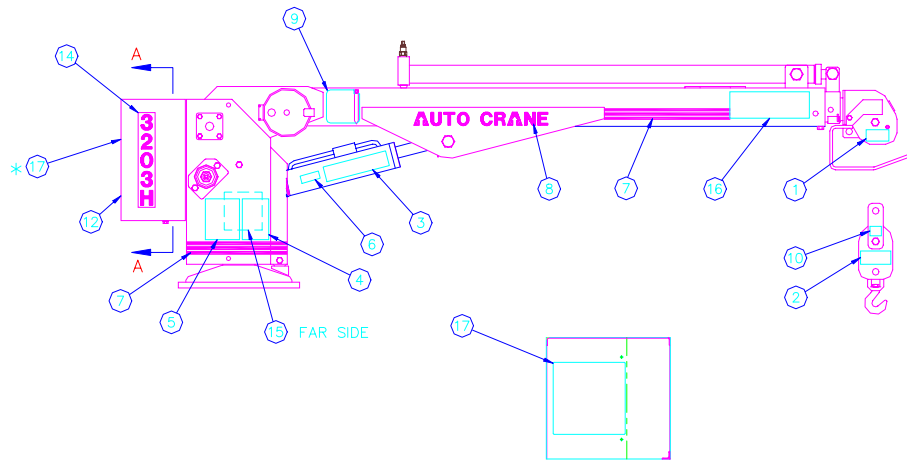

SECTION A-A

NOTE

* LOCATED INSIDE COVER

<u>ITEM</u>	<u>QTY</u>	<u>P/N</u>	<u>DESCRIPTION</u>
1	1	040517	DANGER "STAY CLEAR OF BOOM" DECAL
2	2	040518	DANGER "STAY CLEAR OF LOAD" DECAL
3	2	040519	DANGER "SCISSORS POINT" DECAL
4	1	040579	CAUTION "INSPECT VEHICLE..." DECAL
5	1	040580	DANGER "AN UNTRAINED OPERATOR..." DECAL
6	1	040587	WARNING "LOAD SENSOR PRE-SET" DECAL
7	7 FT	040620	3M STRIPING DECAL
8	2	040624-001	3M AUTO CRANE DECAL
9	1	320318	ANGLE INDICATOR DECAL
10	1	320433-100	TRAVEL BLOCK DECAL
11	1	330622	SERIAL NUMBER DECAL
12	1	360034	3M LOGO DECAL
13	1	367251	ELECTRICAL SCHEMATIC DECAL
14	2	320739	3203H DECAL
15	2	320715	3203H LOAD CHART DECAL
16	2	040529	DANGER "ELECTROCUTION HAZARD" DECAL
*17	1	320331	DECAL ELECTRICAL SCHEMATIC

LUBRICATION & MAINTENANCE SCHEDULE 3203H SERIES CRANE

SERVICE PERFORMED	DAY	WEEK	MONTH	6 MOS	YEAR	NOTES
LOAD HOOK	X					INSPECT HOOK & LATCH FOR DEFORMATION, CRACKS, & CORROSION
CABLE DRUM	X					MAKE SURE CABLE IS WOUND EVENLY ON DRUM
HOIST CABLE	X					CHECK FOR FLATTENING, KINKS, & BROKEN STRANDS, SEE MANUAL
HYD. HOSES	X					VISUAL INSPECTION
MOUNTING BOLTS		X				CHECK-TORQUE TO 85 FT-LBS (DRY) AS REQUIRED
MOTOR CONNECTION		X				CHECK TERMINALS FOR TIGHT CONNECTIONS
SHEAVE BEARINGS		X				SEALED BEARING, REPLACE IF ROUGH OR LOOSE
ALL OTHER BOLTS		X				CHECK-TIGHTEN AS REQUIRED
BOOM PIVOT		X				GREASE WITH MOBILPLEX EP-2 OR EQUIVALENT @ ZERKS
BOOM CYLINDER		X				CHECK AROUND CYLINDER ROD FOR EXCESS FLUID LEAKAGE
BOOM CYLINDER PINS		X				GREASE WITH MOBILPLEX EP-2 OR EQUIVALENT @ ZERKS
EXTENSION CYLINDER		X				CHECK AROUND CYLINDER ROD FOR EXCESS FLUID LEAKAGE
BOOM PIVOT		X				GREASE WITH MOBILPLEX EP-2 OR EQUIVALENT @ ZERKS
EXT. CYLINDER BOLTS		X				CHECK TIGHTNESS
BATTERY CONNECTIONS		X				CHECK FOR CORROSION & TIGHT CONNECTIONS. CLEAN & COAT AS REQUIRED
ROTATION GEAR		X				WATER PROOF BEARING GREASE OR DRY MOLYLUBE IF DUSTY
HYDRAULIC FILTER			X			REMOVE AND CLEAN WITH SOLVENT OR REPLACE IF NEEDED
EXT. CYLINDER BOLTS			X			GREASE WITH MOBILPLEX EP-2 OR EQUIVALENT
SAFETY DECALS			X			INSPECT AND REPLACE AS NEEDED
POWER CABLE			X			CHECK INSULATION FOR DAMAGE OR DETERIORATION

LUBRICATION & MAINTENANCE SCHEDULE 3203H SERIES CRANE

SERVICE PERFORMED	DAY	WEEK	MONTH	6 MOS	YEAR	NOTES
ROTATION WORM BEARINGS (MR) (PR)				X		GREASE WITH MOBILPLEX EP-2 OR EQUIVALENT @ ZERKS
HOIST GEARBOX				X		WORM GEAR-EP GEAR LUBE SAE 80-90, SPUR GEAR SAE 30 OIL
HYDRAULIC FLUID					X	DRAIN, FLUSH, & REFILL WITH MOBIL DTE 13, OR EQUIVALENT
ROTATION BEARINGS	SEALED BEARING-NO MAINTENANCE REQUIRED					
BOOM SLIDE PADS	PADS GREASED WHEN REPLACED					
FOR ADDITIONAL INFORMATION SEE:	1) OWNER'S MANUAL 2) OSHA SECTION 1910.180 3) ANSI B30.5-1989					

CAUTION

Routine maintenance insures trouble-free operation and protects your investment. All warranties are void if maintenance is neglected.

NOTES:

- ◆ Use only authorized parts. Any damage or malfunction caused by the use of unauthorized parts is not covered by Warranty or Product Liability.
- ◆ Once a bolt has been torqued to its rated capacity and then removed; the bolt should be replaced with a new one.
- ◆ “Crane Inspection Log” P/N
999978. These logs should be filled in at the intervals noted and kept as a permanent record.

ASSEMBLY & INSTALLATION INSTRUCTIONS

3203H SERIES

NOTE: For mounting bolt hole pattern - see page 5-1.0.0.

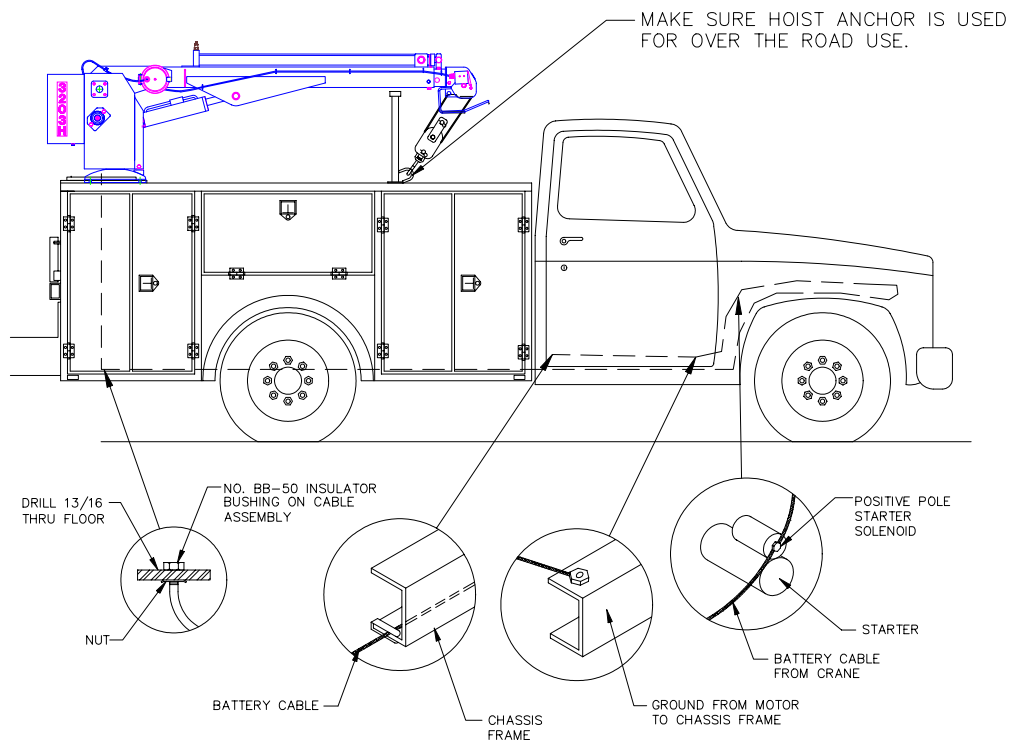

INSTALLATION - BATTERY CABLE

1. Drill 13/16" hole in floor. Install bushing, which is connected to cable, so it fits hole snug.
2. Run cable to positive battery terminal. Connect black cable to negative battery terminal or suitable chassis ground point. Locate cables so that they will be protected. Avoid sharp edges. Use the No. 083800 frame clips provided to hold cables securely in place.
3. If the battery is grounded to the engine it may be necessary to add an additional ground cable from the engine to the chassis frame to obtain maximum power at crane

BOOM SUPPORT

3203H SERIES

WARNING:

As with all Auto Crane power rotation units, the 3203H does require a boom support.

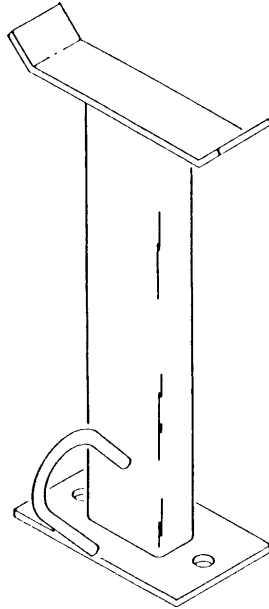

**Suggested Boom Support:
Auto Crane P/N 725045**

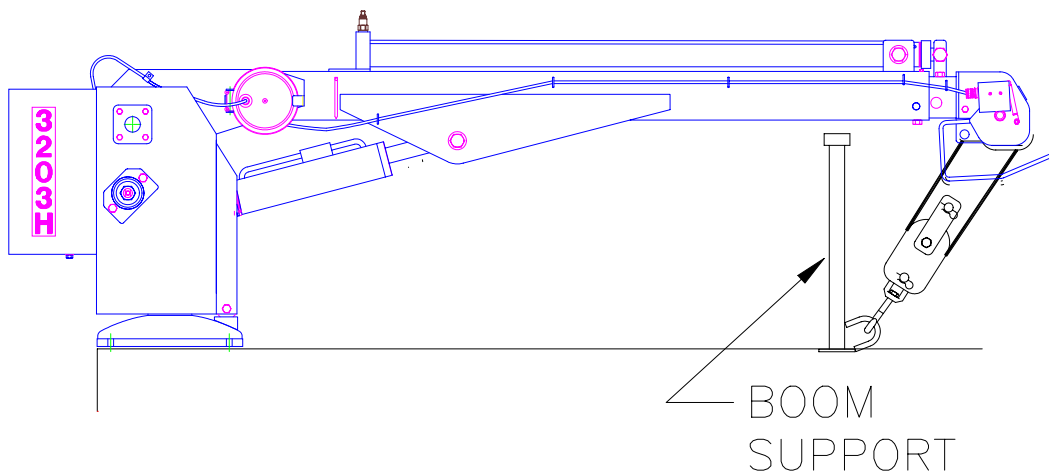

UNIT LESS BOOM ASSEMBLY

P/N 320705 - 3203H SERIES

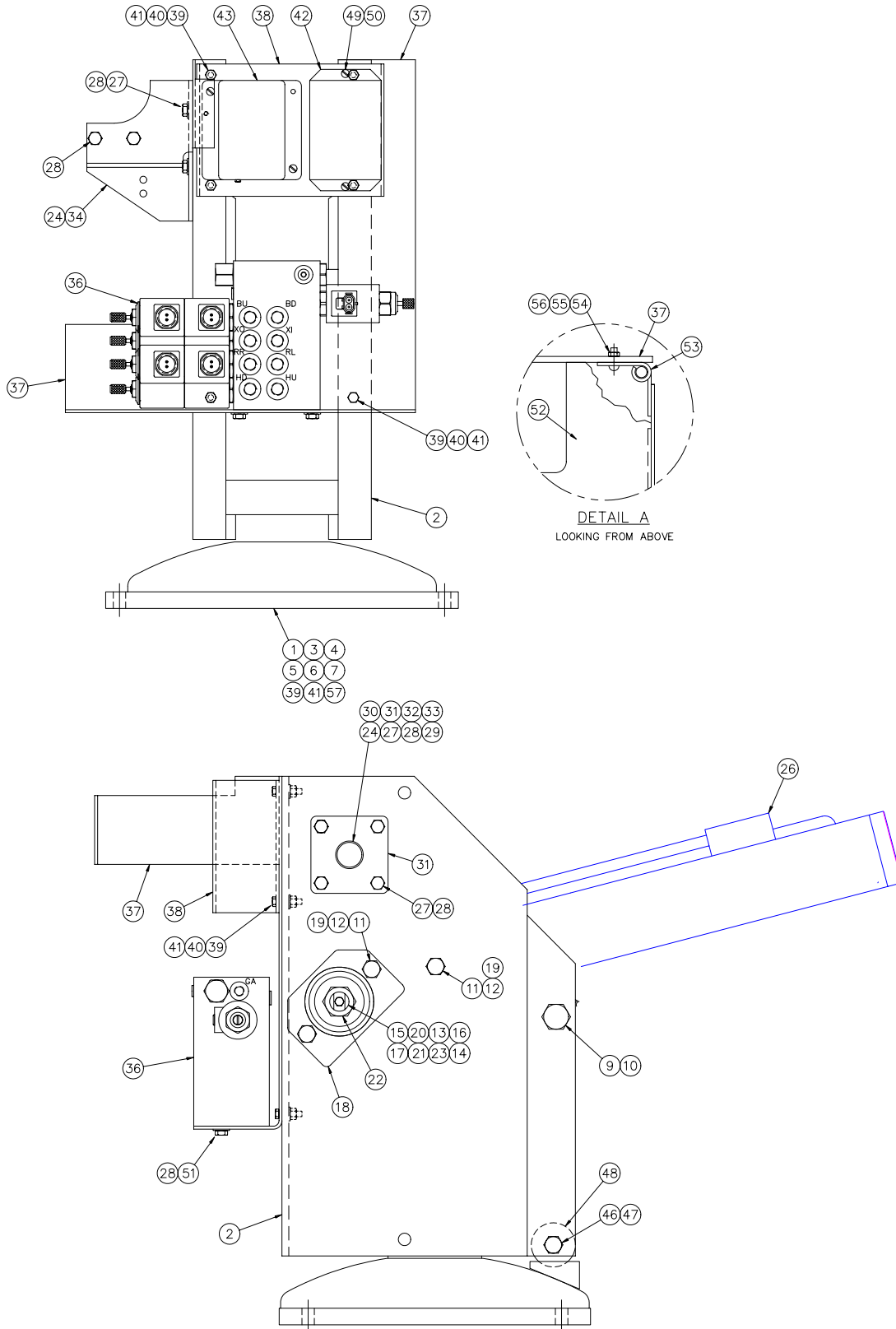

UNIT LESS BOOM ASSEMBLY

P/N 320705 - 3203H SERIES

<u>ITEM</u>	<u>QTY</u>	<u>P/N</u>	<u>DESCRIPTION</u>
1	1	320710	QUILL BASE
2	1	320428	SIDE PLATE ASSEMBLY
3	2	320330	SEALED BALL BEARING
4	1	320332	RETAINING BEARING RING
5	1	320334	WORM GEAR
6	1	340602	SQUARE KEY 3/4
7	1	320333	SNAP RING
8	1	320712	BOOM CYLINDER
9	1	014304	CAPSCREW 3/4-16 NF x 6
10	1	018600	HALF LOCK NUT 3/4-16 NF
11	4	017701	NUT 1/2-13 NC
12	6	021500	LOCK WASHER 1/2
13	1	330484	SPACER
14	2	011603	CAPSCREW 1/2-13 NC x 1 3/4
15	1	330420	SHAFT ASSEMBLY
16	2	330486	OIL SEAL
17	2	330485	BEARING
18	1	320760	HOUSING
19	2	010201	CAPSCREW 1/2-13 NC x 1 1/2
20	1	239300	GREASE ZERK
21	1	330483	SPACER
22	1	019000	HEX NUT 7/8-14 NF
23	1	320740	ROTATION MOTOR
24	1	320726	HOIST ACTUATOR
25	1	320741	HOIST MOTOR
26	8	330394	CAPSCREW 3/8-16 NC x 1 1/2
27	8	021100	LOCK WASHER 3/8
28	1	320379	DRUM
29	2	330468	SPLIT LOCK COLLAR
30	1	320368	BEARING RETAINER
31	4	007807	CAPSCREW 5/16-18 NC x 3/4
32	4	020600	LOCK WASHER 5/16
33	1	320464	ACTUATOR BRACKET
34	1	320714	HYDRAULIC SWIVEL
35	1	320725	HYDRAULIC MANIFOLD
36	1	320722	HYDRAULIC MANIFOLD MOUNTING BRACKET
37	1	320721	AMP/BLACK BOX MOUNTING

UNIT LESS BOOM ASSEMBLY

P/N 320705 - 3203H SERIES

<u>ITEM</u>	<u>QTY</u>	<u>P/N</u>	<u>DESCRIPTION</u>
39	7	005604	CAPSCREW 1/4-20 NC x 1
40	6	015900	NUT 1/4-20 NC
41	8	020200	LOCK WASHER 1/4
42	1	REF	PROPORTIONAL AMPLIFIER <i>(not included)</i> (320742)
43	1	REF	RELAY BOX ASSEMBLY (320773)
44	1	320730	CONTROL CABLE ASSEMBLY
45	1	320723	SWIVEL BRACE ASSEMBLY
46	1	011600	CAPSCREW 1/2-13 NC x 6
47	1	017699	LOCK NUT 1/2-13 NC
48	1	320729	ROTATION STOP SLIDE
49	4	002609	ROUND HEAD SCREW #10-32 NF x 5/8
50	4	019800	LOCK WASHER #10
51	2	008400	CAPSCREW 3/8-16 NC x 3/4
52	1	320736	REAR COVER
53	1	REF	CONTINUOUS HINGE x 5/8 <i>(not included)</i> (320766)
54	4	001207	PAN HEAD SCREW #8 x 1
55	4	015500	NUT #8
56	1	005901	CAPSCREW 1/4-20 NC x 1 1/2
57	1	320749	SWIVEL STOP
58	2	012197	SOCKET HEAD SCREW 1/2-13 NC x 1 1/2

BOOM ASSEMBLY

P/N 320706 - 3203H SERIES

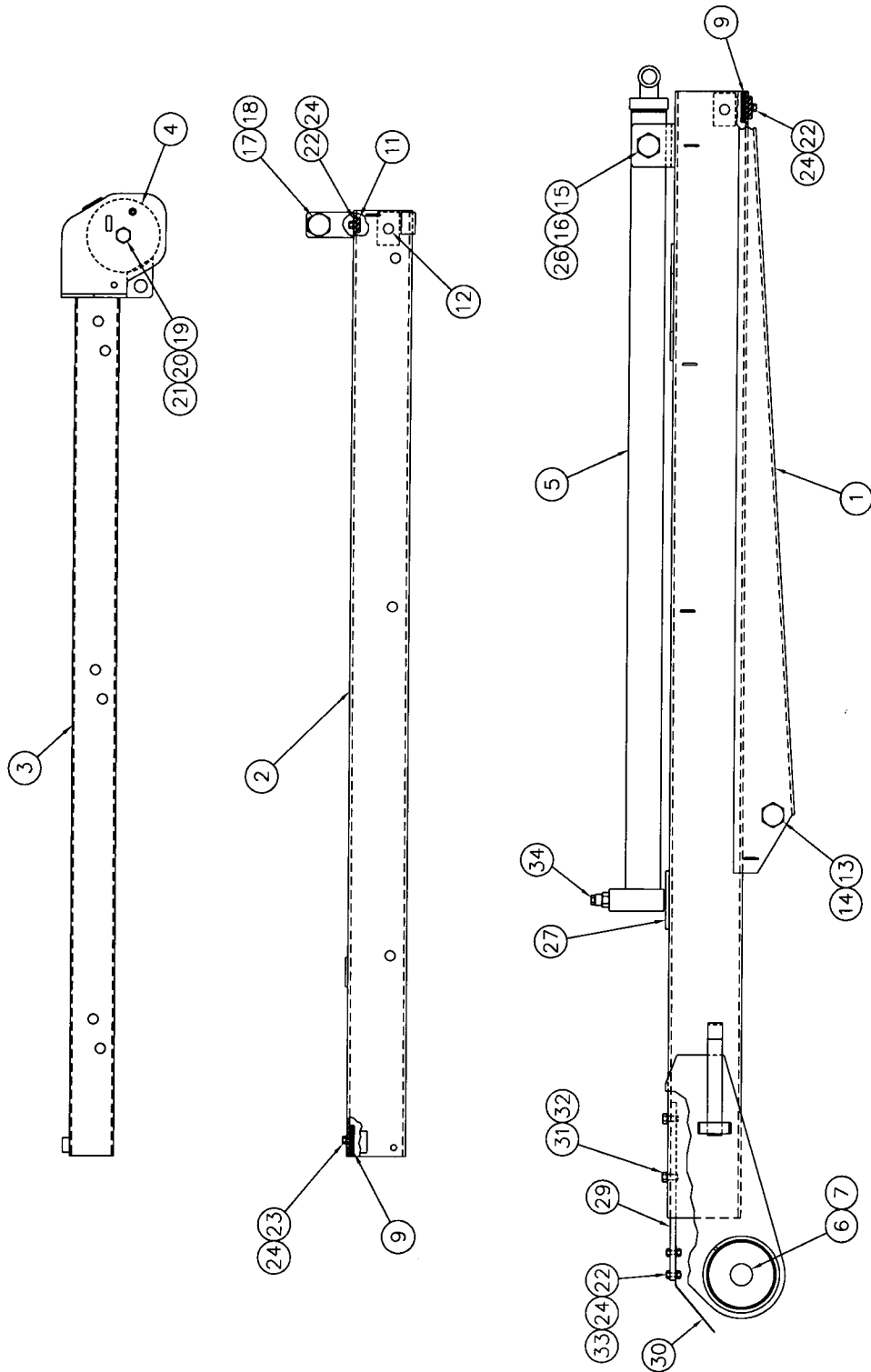

BOOM ASSEMBLY

P/N 320706 - 3203H SERIES

<u>ITEM</u>	<u>QTY</u>	<u>P/N</u>	<u>DESCRIPTION</u>
1	1	320750	LOWER WELD BOOM
2	1	320421	MID BOOM
3	1	320423-001	MANUAL BOOM w/ CROWN
4	1	227401	SHEAVE ASSEMBLY (REF BEARING ONLY P/N 200100)
5	1	320713	EXTENSION CYLINDER
6	2	320411	BOOM PIVOT
7	2	400500	BOOM PIVOT BEARING
8	1	320453	ANGLE INDICATOR
9	2	480036	BOOM PAD (NYLATRON)
10	1	320391	MID BOOM RETAINER
11	1	320415	MANUAL BOOM RETAINER
12	1	370002	PIN ASSEMBLY w/ LANYARD
13	1	330185	CAPSCREW 1-12 NF x 5 1/2
14	1	019106	HALF LOCK NUT 1-12 NF
15	2	015017	CAPSCREW 1-8 NF x 1 1/8
16	2	022502	FLAT WASHER 1
17	1	330057	CAPSCREW 1-8 NC x 4
18	1	019105	NUT 1-8 NC
19	1	012701	CAPSCREW 5/8-18 NF x3
20	1	018100	HALF LOCK NUT 5/8-18 NF
21	1	340295	ROUNDED TUBING 1 1/16 x .188W x 1 3/16
22	5	005501	CAPSCREW 1/4-28 NF x 3/4
23	2	005406	CAPSCREW 1/4-28 NF x 1/2
24	7	020200	LOCK WASHER 1/4
25	1	016300	LOCK NUT 1/4-20 NC
26	2	002905	SET SCREW
27	1	340730	ADHESIVE PAD
28	1	320755	LEVEL WIND BAR
29	1	270389	CABLE GUARD
30	2	008400	CAPSCREW 3/8-16 NC x 3/4
31	2	021100	LOCK WASHER 3/8
32	2	016100	NUT 1/4-28 NF
33	1	REF	COUNTERBALANCE VALVE CARTRIDGE (480188)

2-BLOCK ASSEMBLY

3203PRX & 3203H SERIES

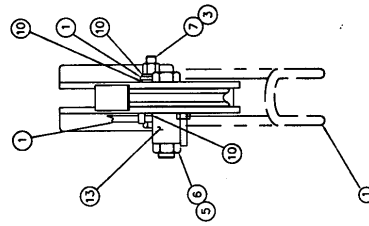
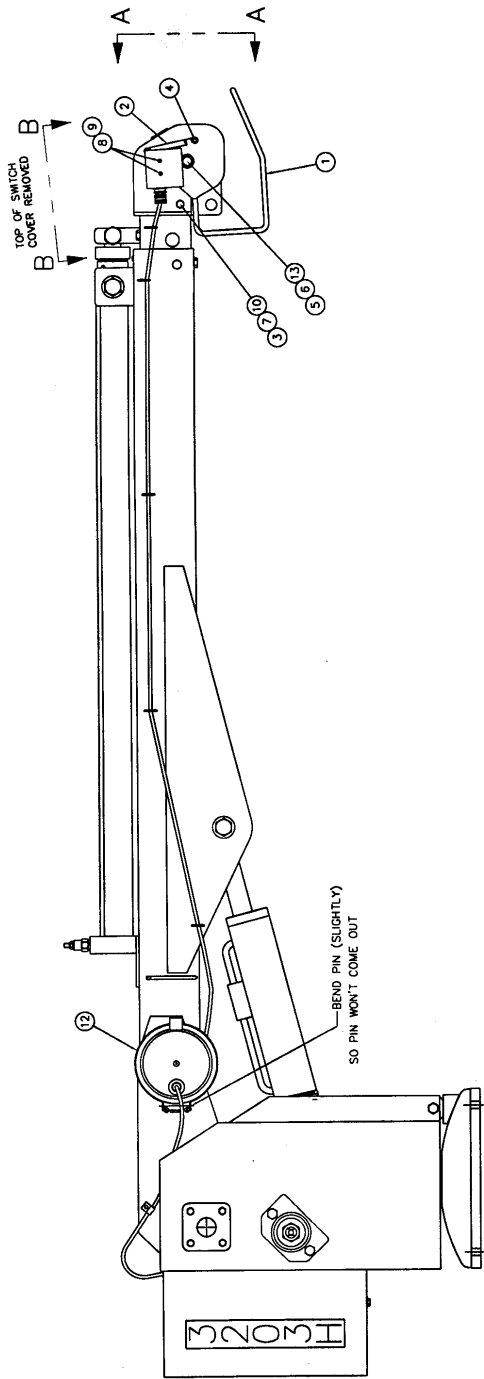

VIEW A-A
SCALE: 1/2
SWITCH REMOVED F/ CLARITY

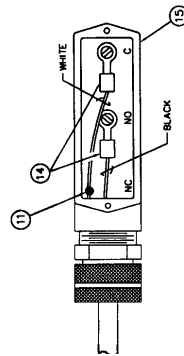

VIEW B-B
(CONN. INSIDE LIMIT SWITCH)
SCALE: NONE

2-BLOCK ASSEMBLY
3203PRX & 3203H SERIES

<u>ITEM</u>	<u>QTY</u>	<u>P/N</u>	<u>DESCRIPTION</u>
1	1	320556	BAIL / SWITCH ASSEMBLY
2	1	320554	SPRING, RETURN
3	1	330372	NUT HX LK 3/8 NC
4	2	016300	NUT HX LK 1/4 NC
5	1	018200	NUT HLF LK 5/8-11NC
6	1	012700	SCW HX HD 5/8-11NC X 3 LG
7	1	759132	SCW HX HD 3/8-11NC X 2 1/2 LG
8	2	019600	WASHER LK #6
9	2	002602	SCW RD HD #6-32NC x 1 1/4 LG
10	3	021200	WASHER FL 3/8
11	1	000302	TERM WIRE BUTT SPLICE 14 GA
12	1	366973-001	CORD REEL ASSY W/WHTR PACK CONN
13	1	340295	TUBING RD 1 1/16 X .188W X 1 3/16 LG
14	2	000101	TERM RING 14-16 GA
15	1	646900	SWITCH

2-BLOCK ASSEMBLY

3203PRX & 3203H SERIES

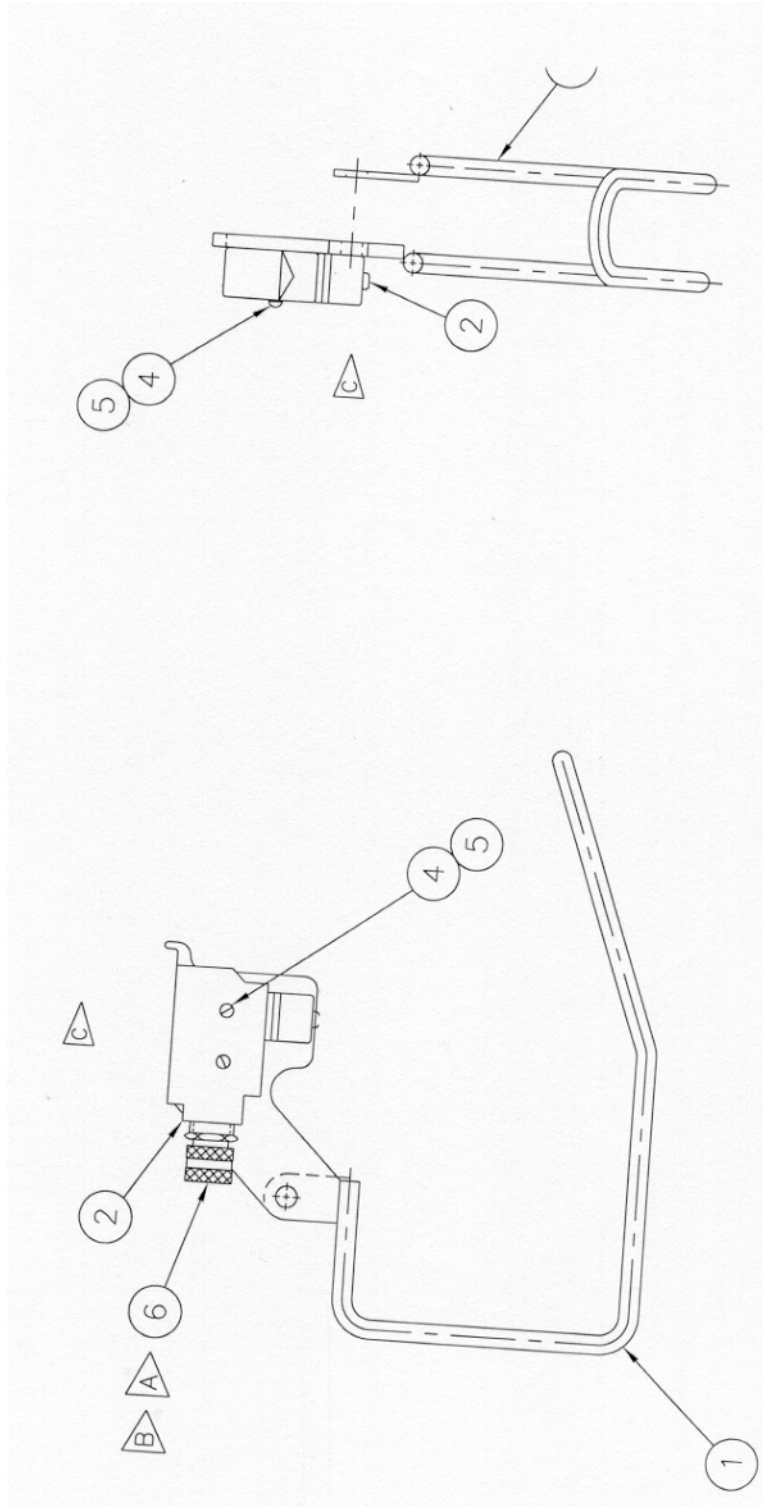

2-BLOCK ASSEMBLY
3203PRX & 3203H SERIES

<u>ITEM</u>	<u>QTY</u>	<u>P/N</u>	<u>DESCRIPTION</u>
1	1	320546	BAIL (WELD)
2	1	646900	SWITCH, LOAD SENSOR
3	2	002602	SCREW, RD HD #6-32NC X 1 ¼ LG
4	2	019600	WASHER, SP LK #6
5	1	642918	CONNECTOR, CORD (STRAIGHT)

2-BLOCK REEL INSTALLATION

3203H/ 3203PRX

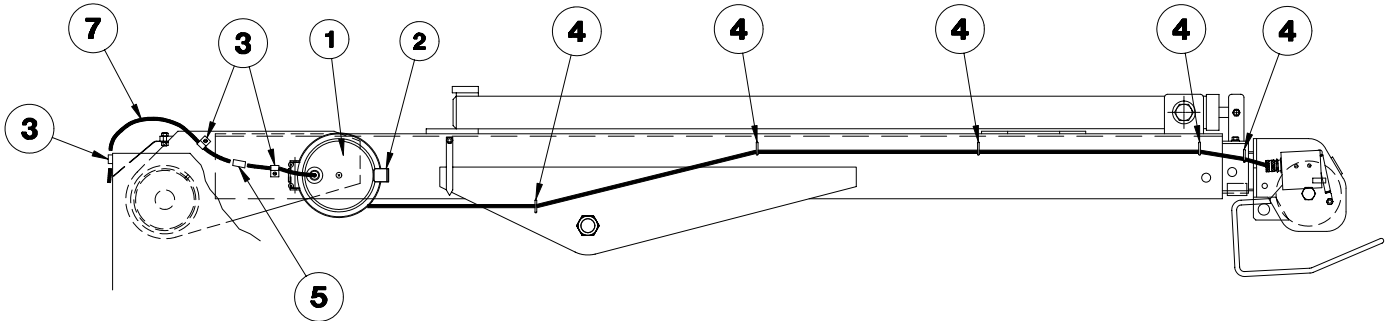

<u>ITEM</u>	<u>QTY</u>	<u>P/N</u>	<u>DESCRIPTION</u>
1	1	320521	CABLE REEL
2	1	320551	REEL MOUNT BRACKET
3	3	000115	#15 JIFFY CLIP
4	5	320570	D-RING
5	2	000302	BUTT SPLICE WIRE TERMINAL
6	1	000300	WIRE TERMINAL
7	3 FT	800626	16GA 2 CONDUCTOR CABLE 300V TYPE SJO BLACK

HOIST ACTUATOR ASSEMBLY

P/N 320726 - 3203H SERIES

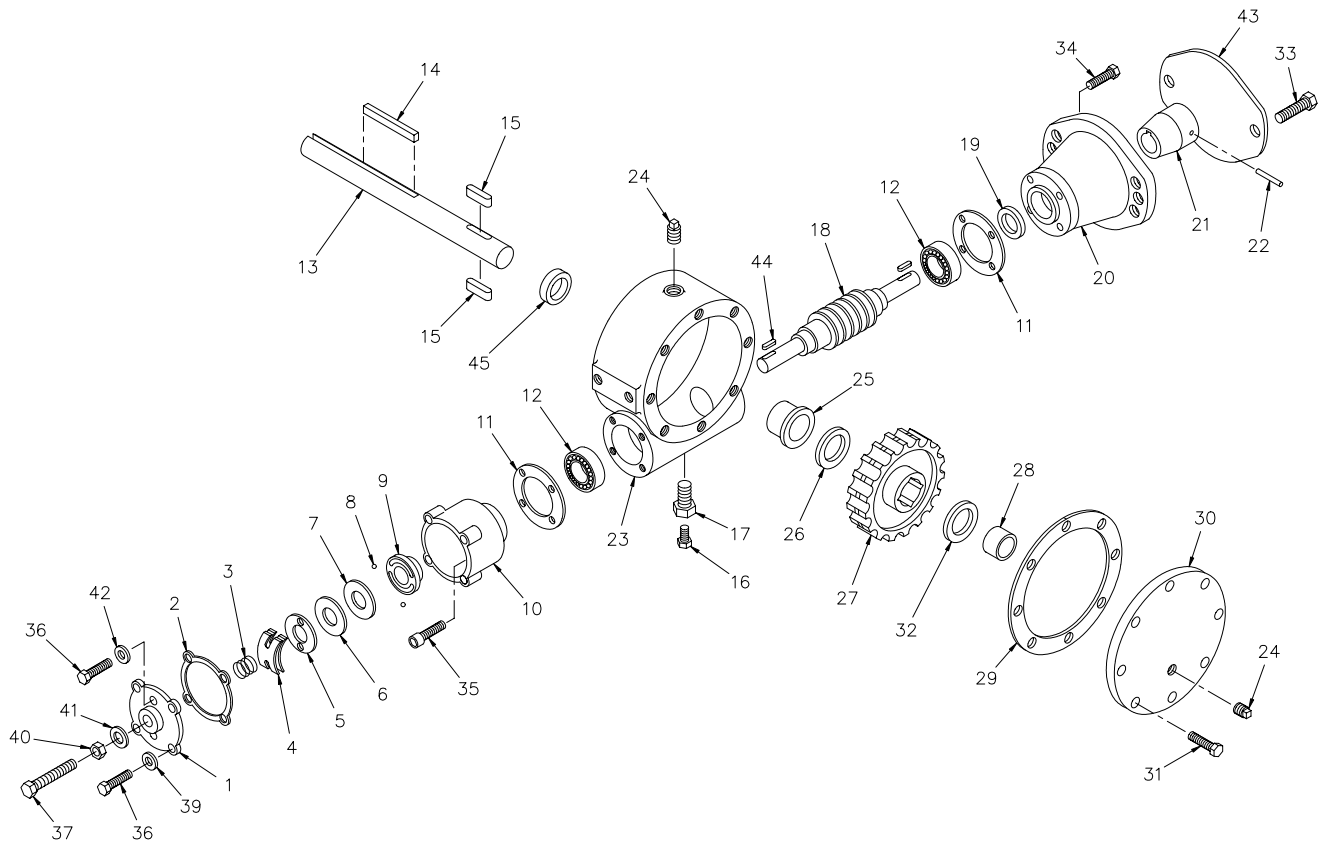

HOIST ACTUATOR ASSEMBLY

P/N 320726 - 3203H SERIES

<u>ITEM</u>	<u>QTY</u>	<u>P/N</u>	<u>DESCRIPTION</u>
1	1	360450	BRAKE HOUSING COVER
2	1	360359	BRAKE HOUSING GASKET
3	1	360368	SPRING
4	2	360367	FLAT SPRING
5	1	360342	RETAINER PLATE
6	1	360364	THRUST PLATE
7	1	360331	CAM PLATE
8	2	360345	BRAKE BALL
9	1	360339	HUB-BRAKE
10	1	360336	BRAKE HOUSING
11	2	300062	GASKET
12	2	300057	BEARING
13	1	320323	OUTPUT SHAFT
14	1	800479-001	3/8 SQ KEY
15	2	300052	BARTH KEY
16	1	300066	RELIEF FITTING
17	1	300074	REDUCER
18	1	320765	WORM RH DL
19	1	300076	OIL SEAL
20	1	360330	ADAPTER
21	1	360332	COUPLING
22	1	360363	SPIRAL PIN
23	1	300048	GEAR HOUSING
24	2	300070	PIPE PLUG
25	1	300059	BUSHING
26	1	300081	THRUST WASHER
27	1	320764	GEAR RH
28	1	320063	BUSHING
29	1	300064	GEAR HOUSING GASKET
30	1	300041	GEAR HOUSING COVER
31	8	360452	HEX HD CAPSCREW 1/4-20NC x 3/4 GR5
32	1	360466	THRUST WASHER
33	2	010202	HEX HD CAPSCREW 1/2-13NC x 1
34	4	360352	SOC HD LOCK-WEL CAPSCREW 1/4-20NC x 1 3/4
35	4	360463	SOC HD CAPSCREW 1/4-20NC x 7/8
36	6	360453	HEX HD ALL THRD CAPSCREW 1/4-20NC x 1 GR5
37	1	360456	HEX HD ALL THRD CAPSCREW 3/8-16NC x 1 1/2
38	-	-	-

HOIST ACTUATOR ASSEMBLY

P/N 320726 - 3203H SERIES

<u>ITEM</u>	<u>QTY</u>	<u>P/N</u>	<u>DESCRIPTION</u>
39	4	360465	THREAD SEAL
40	1	360353	HEX JAM NUT 3/8-16NC
41	1	360371	THREAD SEAL
42	1	360455	FLAT WASHER 1/4 ALUM
43	1	480255	COVER
44	2	360341	KEY
45	1	300077	OIL SEAL

TURNER ASSEMBLY (HYDRAULIC)

3203H SERIES

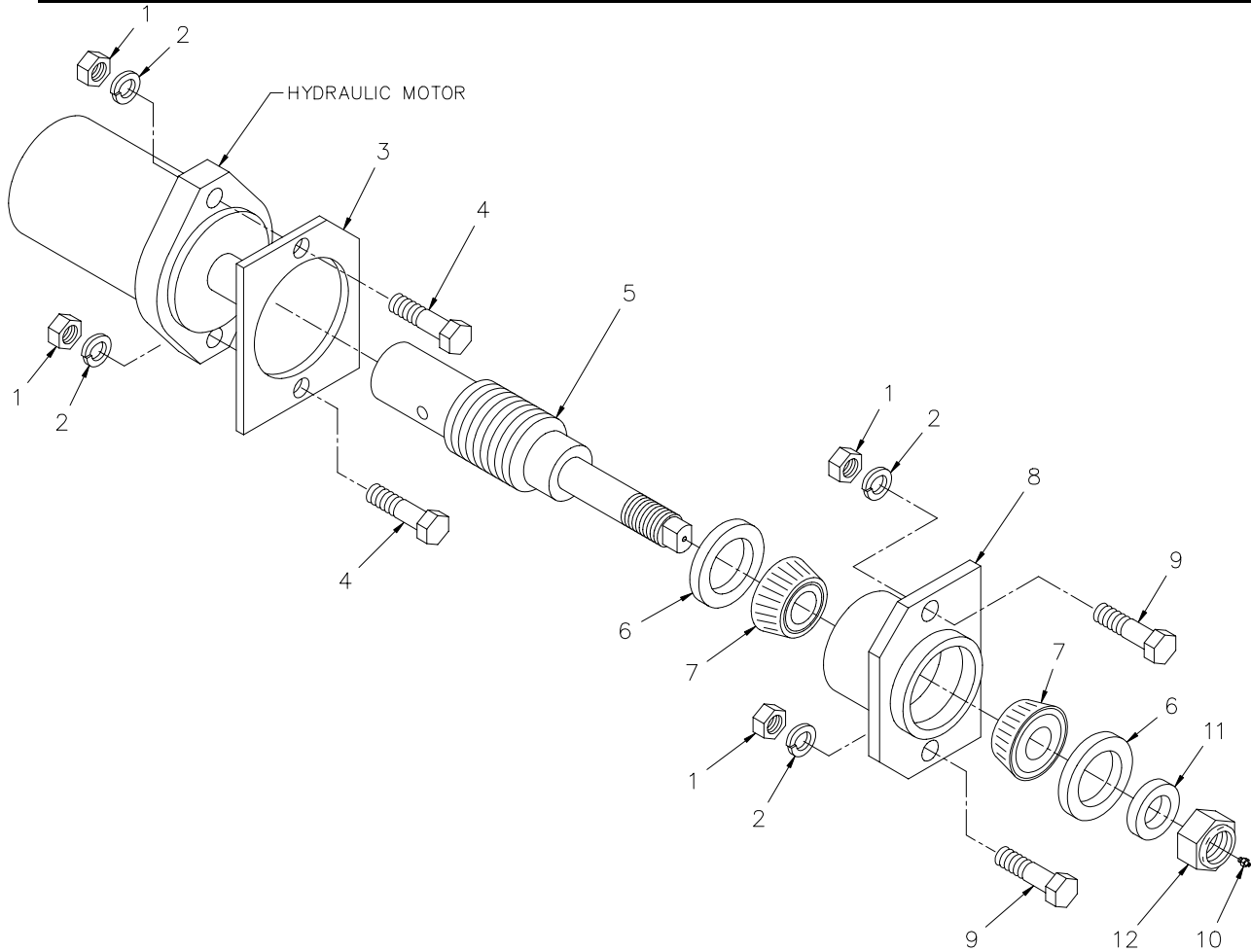

<u>ITEM</u>	<u>QTY</u>	<u>P/N</u>	<u>DESCRIPTION</u>
1	4	017701	HEX NUT 1/2-13NC
2	4	021500	LOCK WASHER 1/2
3	1	330484	SPACER
4	2	011603	HEX HD SCREW 1/2-13NC x 1 3/4 GR5
5	1	330420	SHAFT ASSEMBLY
6	2	330486	OIL SEAL
7	2	330485	BEARING
8	1	320760	HOUSING
9	2	010201	HEX HD SCREW 1/2-13NC x 1 1/2 GR5
10	1	239300	GREASE ZERK
11	1	330483	SPACER
12	1	019000	HEX LOCK NUT 7/8-14NF

TRAVELING BLOCK ASSEMBLY

P/N 320433

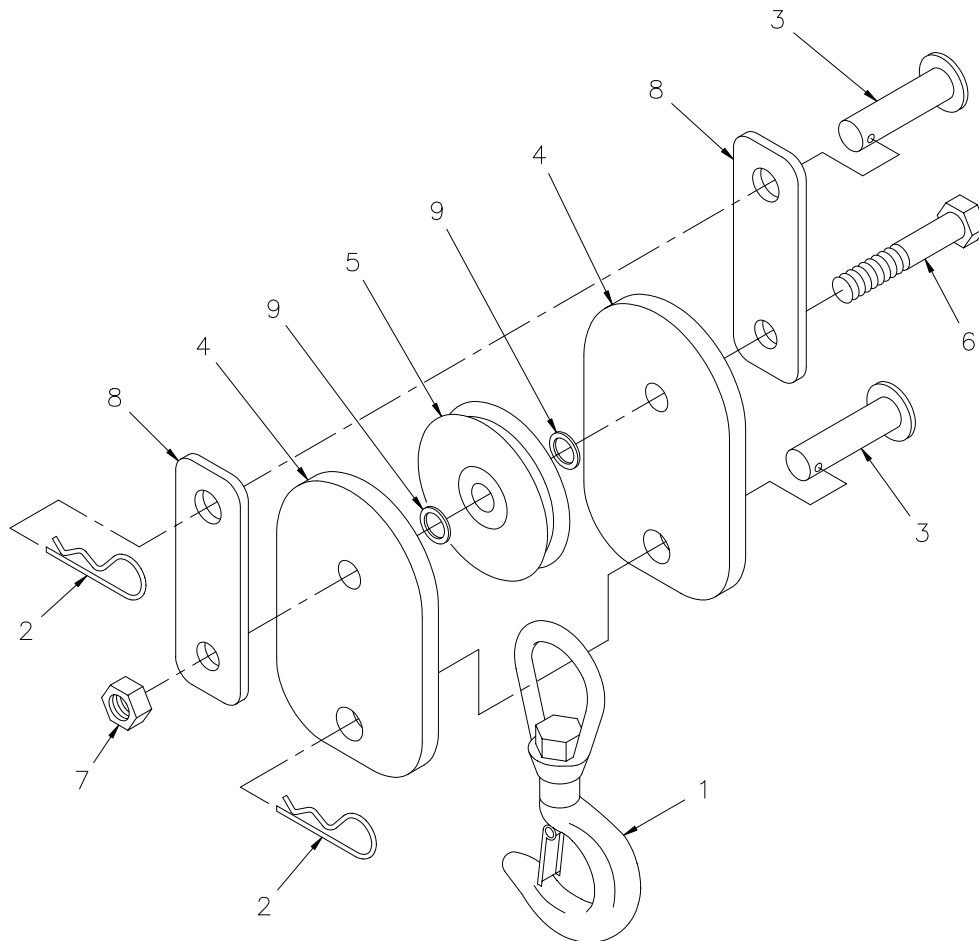

<u>ITEM</u>	<u>QTY</u>	<u>P/N</u>	<u>DESCRIPTION</u>
1	1	100309	SWIVEL HOOK
2	2	360124	HITCH PIN
3	2	320434	BLOCK PIN
4	2	320403	TRAVELING BLOCK
5	1	200909	SHEAVE ASSEMBLY w/ BEARING
6	1	013512	HEX HD SCREW 5/8 NC x 3 1/2
7	1	018200	HEX HALF LOCK NUT 5/8 NC
8	2	320404	BLOCK
9	2	330100	FLAT WASHER

NOTE: STANDARD 62' CABLE ASSEMBLY MAY BE ORDERED USING P/N 320338.
OPTIONAL 75' CABLE ASSEMBLY MAY BE ORDERED USING P/N 320339.

AUTOMATIC SAFETY BRAKE ASSEMBLY (OIL COOLED) HOIST

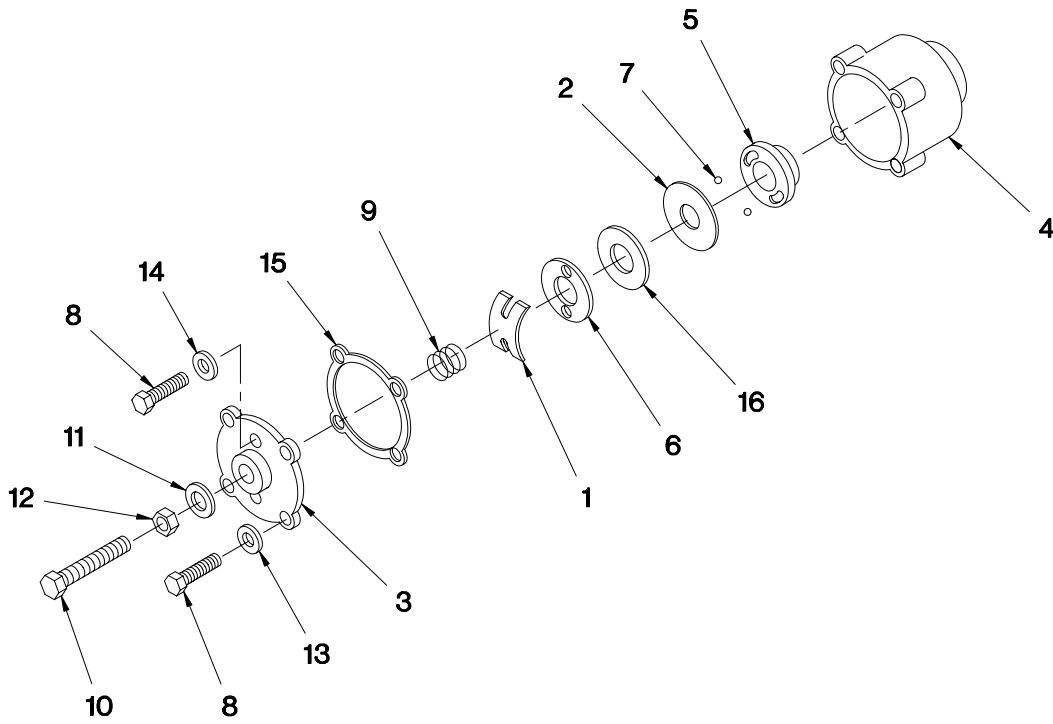

<u>ITEM</u>	<u>QTY</u>	<u>P/N</u>	<u>DESCRIPTION</u>
1	1	360367	FLAT SPRING
2	1	360331	CAM PLATE
3	1	360450	HOUSING COVER
4	1	360336	BRAKE HOUSING
5	1	360339	BRAKE HUB
6	1	360342	RETAINER PLATE
7	2	360345	BRAKE BALL
8	6	360453	CAPSCREW 1/4 NC x 1
9	1	360368	COIL SPRING
10	1	360456	CAPSCREW 3/8 NC x 1 1/2
11	1	360371	THREAD SEAL
12	1	360353	JAM NUT 3/8 NC
13	4	360465	THREAD SEAL
14	2	360455	WASHER FLAT 1/4 ALUM
15	1	360359	GASKET
16	1	360364	THRUST PLATE

AUTOMATIC SAFETY BRAKE ASSEMBLY

(OIL COOLED) HOIST

ASSEMBLY INSTRUCTIONS:

1. Winch has right hand worm and gear. Cable spools over drum. Use number one slots for brake balls(7) in cam plate(2).
2. Install brake hub(5) through brake housing(4) on winch worm with key.
3. Assemble balls(7) in cam plate(2) using hard grease to hold balls in place.
4. Place cam plate(2) on brake hub(5), matching its holes with the balls.
5. Install thrust plate(16).
6. Thread capscrew(10) with jam nut (12) and thread seal (11) through housing cover(3).
7. Place gasket(15) on housing cover(3).
8. Install coil spring(9) on capscrew(10).
9. Install flat spring(1) on capscrew(10).
10. Secure retainer plate(6) and flat spring(1) to housing cover(3) using capscrews(8) and washers(14).
11. Using capscrews(8) and thread seals(13) attach housing cover(3) to brake housing(4).
12. Test brake by shifting winch to UP then DOWN to see if brake is working in proper rotation. If not, remove housing cover(3) and locate brake balls(7) in opposite set of slots of cam plate(2).
13. Adjust to suit by tightening or loosening capscrew(10) on outside of housing cover(3). When proper adjustment is obtained, secure capscrew(10) with jam nut(12).

GENERAL DIMENSIONS

3203H SERIES

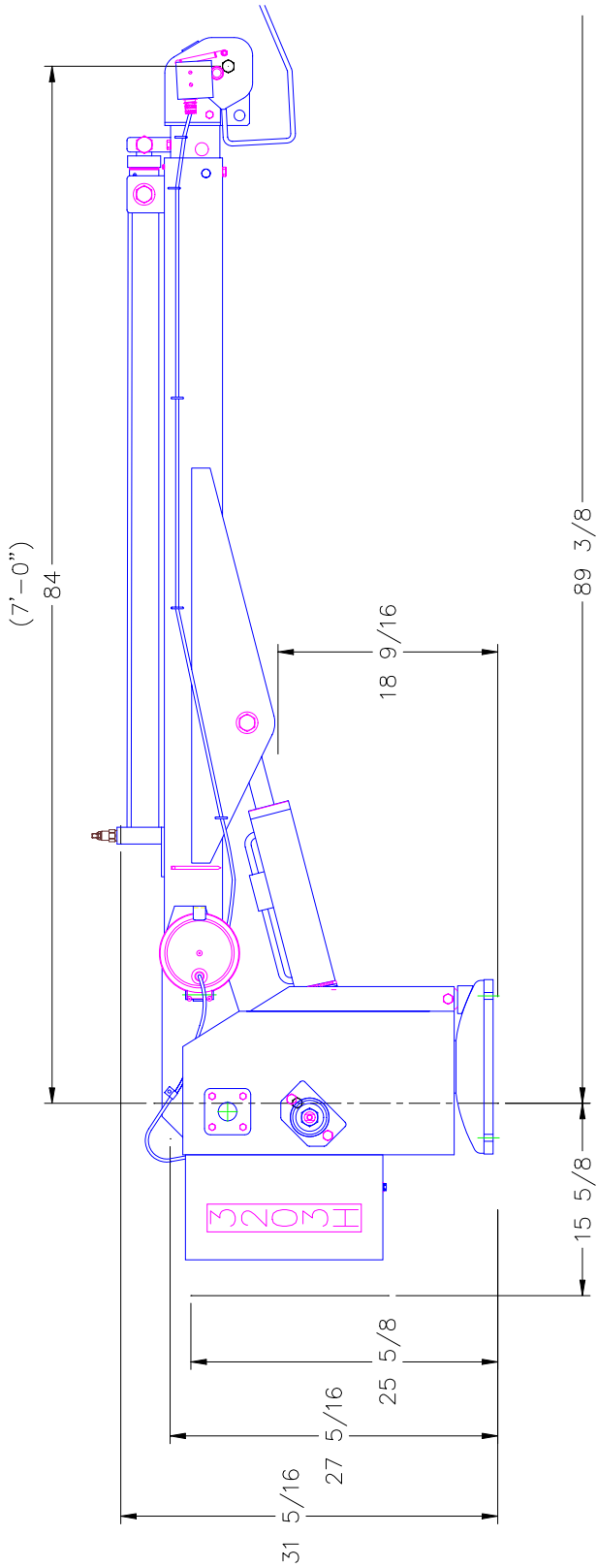

NOTE:
ROTATION CLEARANCE = 16 1/2"
@ BACK RIGHT CORNER OF COVER

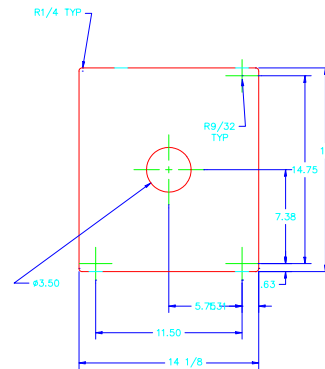

ELECTRICAL ASSEMBLY

P/N 320707 - 3203H SERIES

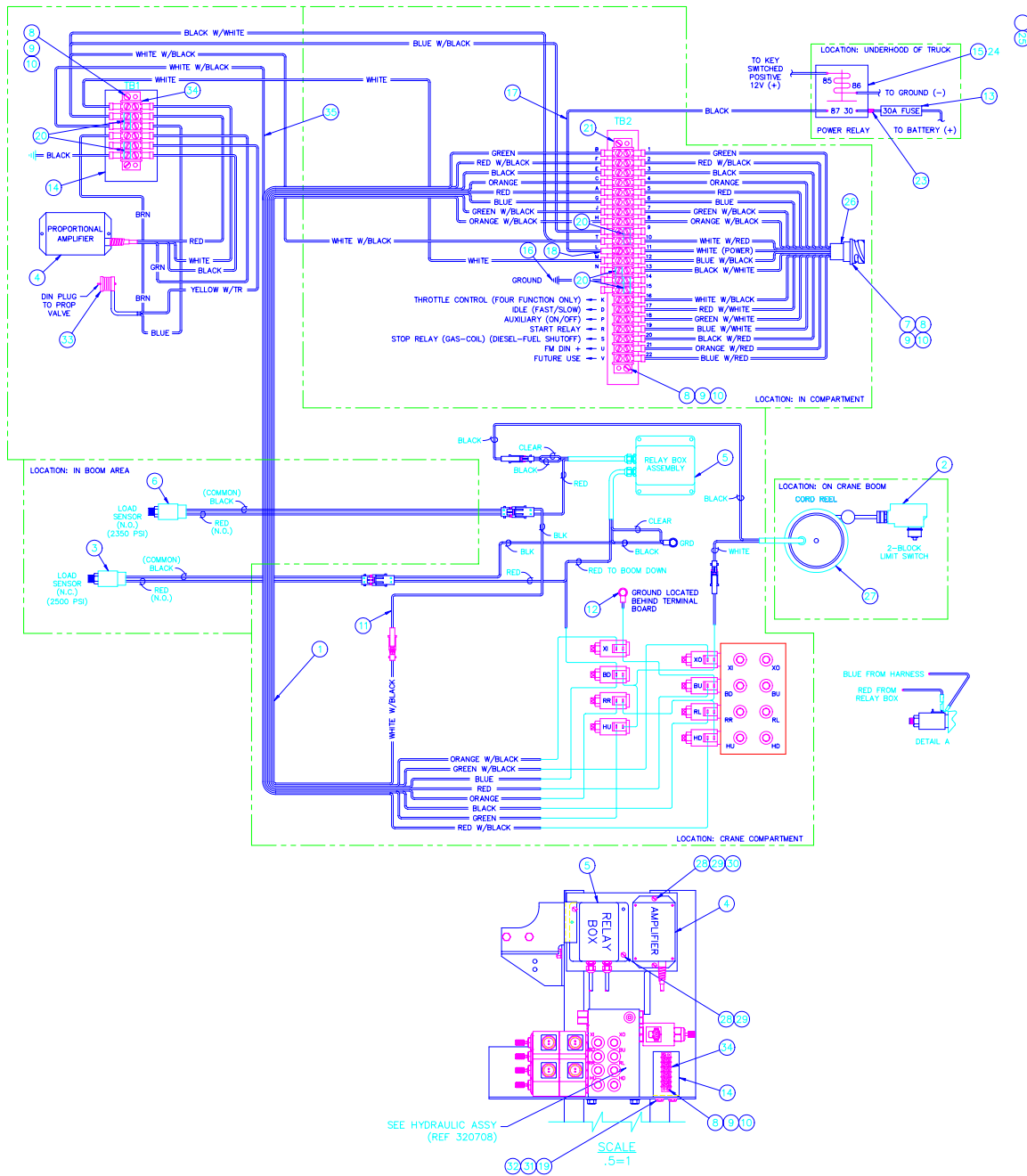

ELECTRICAL ASSEMBLY

P/N 320707 - 3203H SERIES

DECAL IS LOCATED INSIDE OF COVER

<u>ITEM</u>	<u>QTY</u>	<u>P/N</u>	<u>DESCRIPTION</u>
1	1	320777	HARNESS WIRING
2	1	REF	SWITCH (646900)
3	1	366032	LOAD SENSOR ASSY
4	1	320742	AMPLIFIER ASSEMBLY PROPORTIONAL
5	1	320773	RELAY BOX ASSEMBLY
6	1	320543	LOAD SENSOR ASSEMBLY
7	1	480547	PENDANT RECEPTACLE CAP <i>(not included)</i>
8	4	000404	RD HD SCREW #6-32 x 5/8
9	4	019600	LOCK WASHER #6
10	4	015400	HEX NUT #6-32
11	1	320775	WIRE HARNESS w/ WEATHER PACK
12	1	320776	GROUND WIRE HARNESS
13	1	750167	IN LINE FUSE 30 AMP
14	1	320778	TERMINAL BOARD BRACKET
15	1	320355	POWER RELAY
16	1	480549	16 GA BLACK CONDUCTOR
17	1	340638	POWER CONDUCTOR
18	1	001002	TERMINAL RING
19	4	005500	HEX HD SCREW 1/4NC x 3/4
20	5	636600	JUMPER
21	1	480494	22 STA TERMINAL BLOCK <i>(not included)</i>
* 22	1	320331	ELECTRICAL SCHEMATIC DECAL <i>(not included)</i>
23	1	001102	TERMINAL WIRE 2RC-10
24	1	320363	RELAY PLUG
25	5	320357	NON-INSULATED LOCKING SPADE CONNECTOR
26	1	480491-080	WIRING HARNESS
27	1	REF	CORD REEL ASSEMBLY (366973-001)
28	4	002607	RD HD SCREW #10 x 3/4
29	4	360476	HEX NUT #10-24
30	4	019800	LOCK WASHER #10
31	5	020200	LOCK WASHER #1/4
32	1	005806	HEX HD SCREW 1/4NC x 2
33	1	320774	DIN CONNECTOR ASSEMBLY
34	1	635203	6 STA TERMINAL BLOCK
35	1	320779	6' WIRE HARNES w/ WEATHER PACK

PROPORTIONAL 8 FUNCTION PENDANT ASSEMBLY

P/N 680040 - 3203H

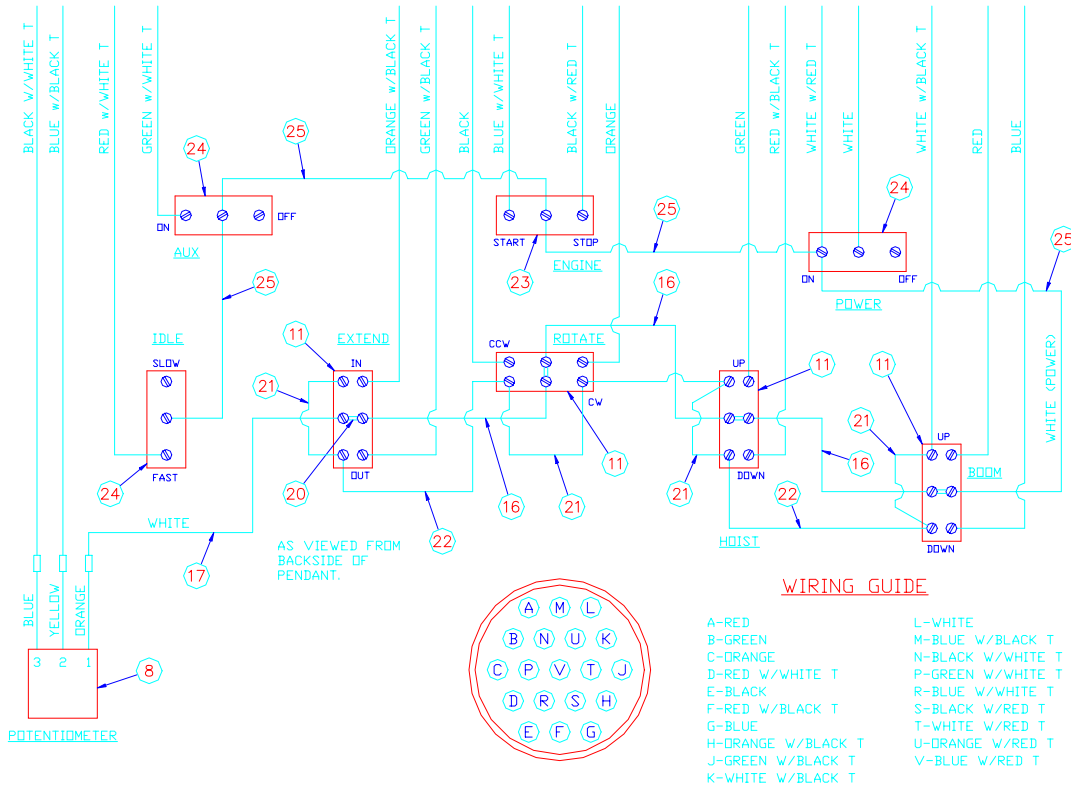
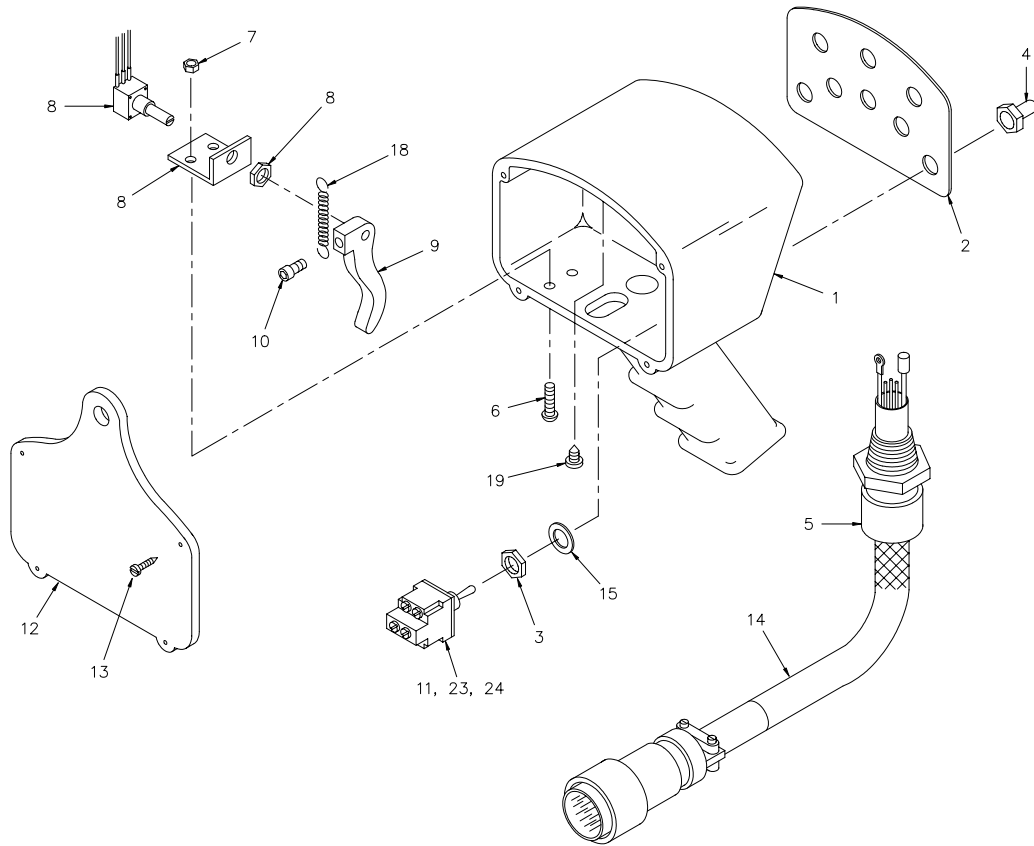

PROPORTIONAL 8 FUNCTION PENDANT ASSEMBLY

P/N 680040 - 3203H

<u>ITEM</u>	<u>QTY</u>	<u>DESCRIPTION</u>
1	1	PENDANT HOUSING
2	1	COVER PLATE DECAL
3	8	NUT
4	8	TOGGLE SWITCH BOOT
5	1	HUBBELL CONNECTOR CORD GRIP
6	2	SCREW #10 NC x 3/4
7	2	HEX LOCK NUT #10 NC
8	1	POTENTIOMETER ASSEMBLY
9	1	TRIGGER
10	1	SOC HD SCREW #10 NF x 5/8
11	4	TOGGLE DPDT SWITCH
12	1	BACK PLATE
13	4	ST RD HD SCREW #6 x 3/4
14	1	CABLE ASSEMBLY
15	8	LOCK WASHER
16	3	CONDUCTOR ASSEMBLY
17	1	CONDUCTOR ASSEMBLY
18	1	TRIGGER RETURN SPRING
19	1	PAN HD ST SCREW #6 x 3/8
20	4	JUMPER
21	4	CONDUCTOR ASSEMBLY 2 1/8
22	3	CONDUCTOR ASSEMBLY 3 1/8
23	1	TOGGLE SPDT SWITCH
24	3	TOGGLE ON/OFF SWITCH
25	1	CONDUCTOR ASSEMBLY
26	2	CABLE TIE

NOTES:

1. Items 5 & 14 may be purchased as replacement Cable Assembly using P/N 380000.
2. Items 6, 7, 8, 9, 10, 18, & 19 may be purchased as a replacement Potentiometer Kit using P/N 380003.
3. Items 1, 2, 12, & 13 may be purchased as a replacement Housing Kit using P/N 380002.
4. Items 3, 4, 11, & 15 may be purchased as a replacement DPDT Switch Kit using P/N 380005.
5. Items 3, 4, 15, & 24 may be purchased as a replacement On/Off Switch Kit using P/N 380001.
6. Items 3, 4, 11, & 23 may be purchased as a replacement SPDT Switch Kit using P/N 380004.

IN-COMPARTMENT (IC) PENDANT

P/N 404147

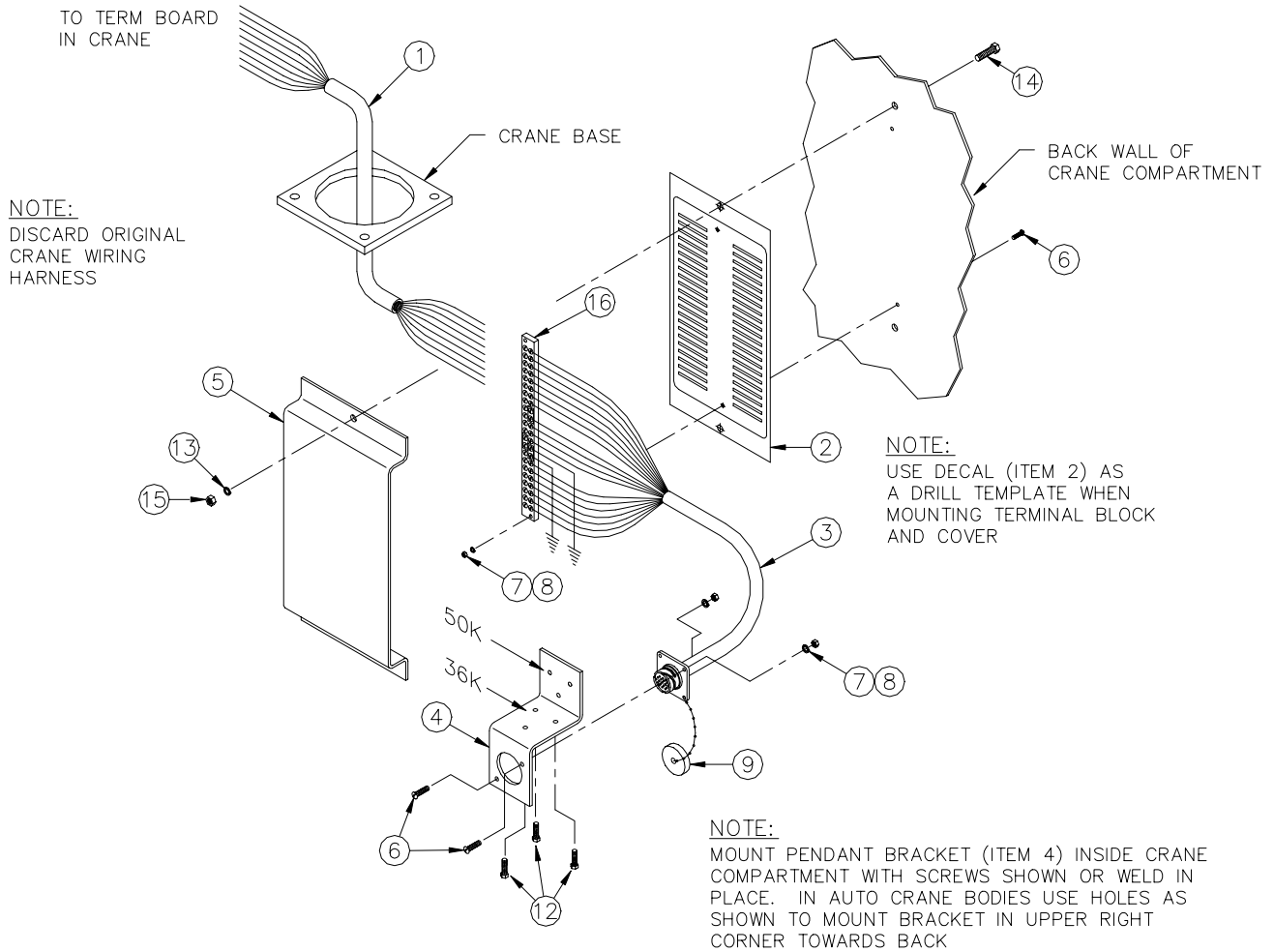

SEE APPROPRIATE CRANE WIRING

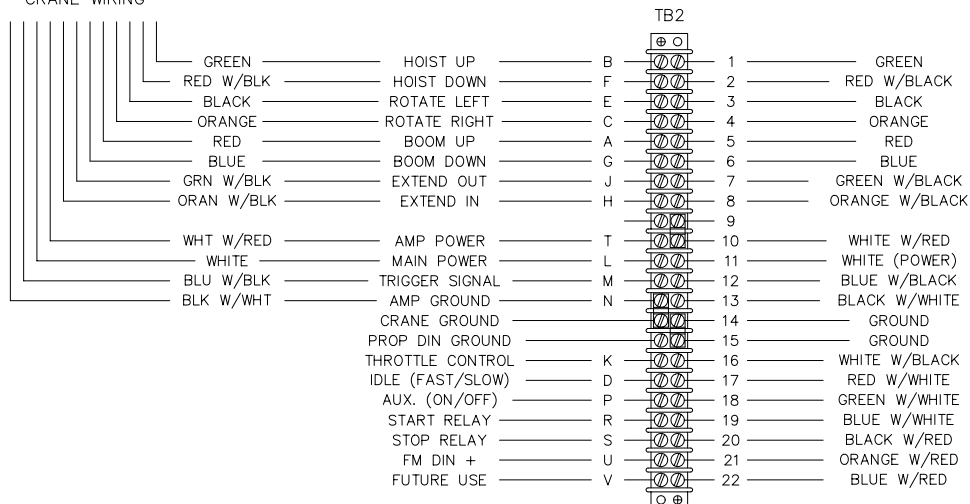

IN-COMPARTMENT (IC) PENDANT

P/N 404147

<u>ITEM</u>	<u>QTY</u>	<u>P/N</u>	<u>DESCRIPTION</u>
1	REF	404148	CRANE PIGTAIL HARNESS
2	1	480490	22 STA TERMINAL BLOCK DECAL
3	1	480491-080	22 STA/19 PIN SOCKET HARNESS
4	1	480626	19 PIN PENDANT BRACKET
5	1	480493	22 STA TERMINAL BLOCK COVER
6	4	000404	RD HD SCREW #6 NC x 5/8
7	4	015400	HEX NUT #6 NC
8	4	019600	SP LK WASHER #6
9	1	366097	19 PIN RECEPTACLE CAP
10	6	750738	STICK ON RETAINER WIRE TIE
11	6	634401	7" WIRE TIE
12	3	330038	HEX HD SELF DRILLING SCREW #10 x 3/4
13	2	020200	SP LK WASHER 1/4
14	2	005500	HEX HD SCREW 1/4 NC x 3/4 GR5
15	2	015900	HEX NUT 1/4 NC
16	1	480494	22 STA TERMINAL BLOCK

HYDRAULIC CONNECTIONS

3203H SERIES

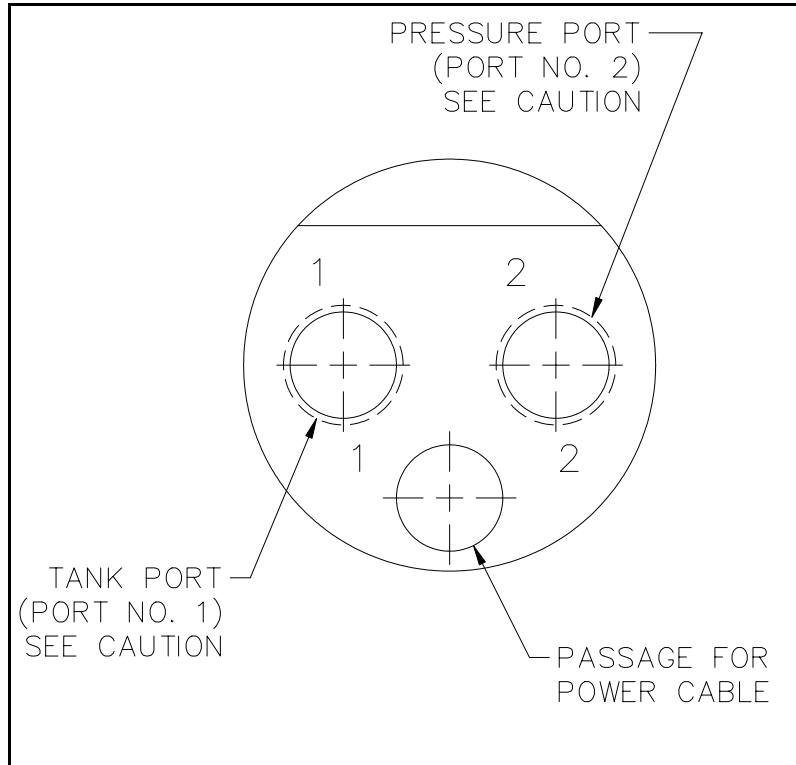

VIEW OF HYDRAULIC SWIVEL FROM BOTTOM OF CRANE

**CAUTION: REVERSING TANK AND PRESSURE
HOSES WILL DAMAGE PUMP**

HYDRAULIC ASSEMBLY

P/N 320708 - 3203H SERIES

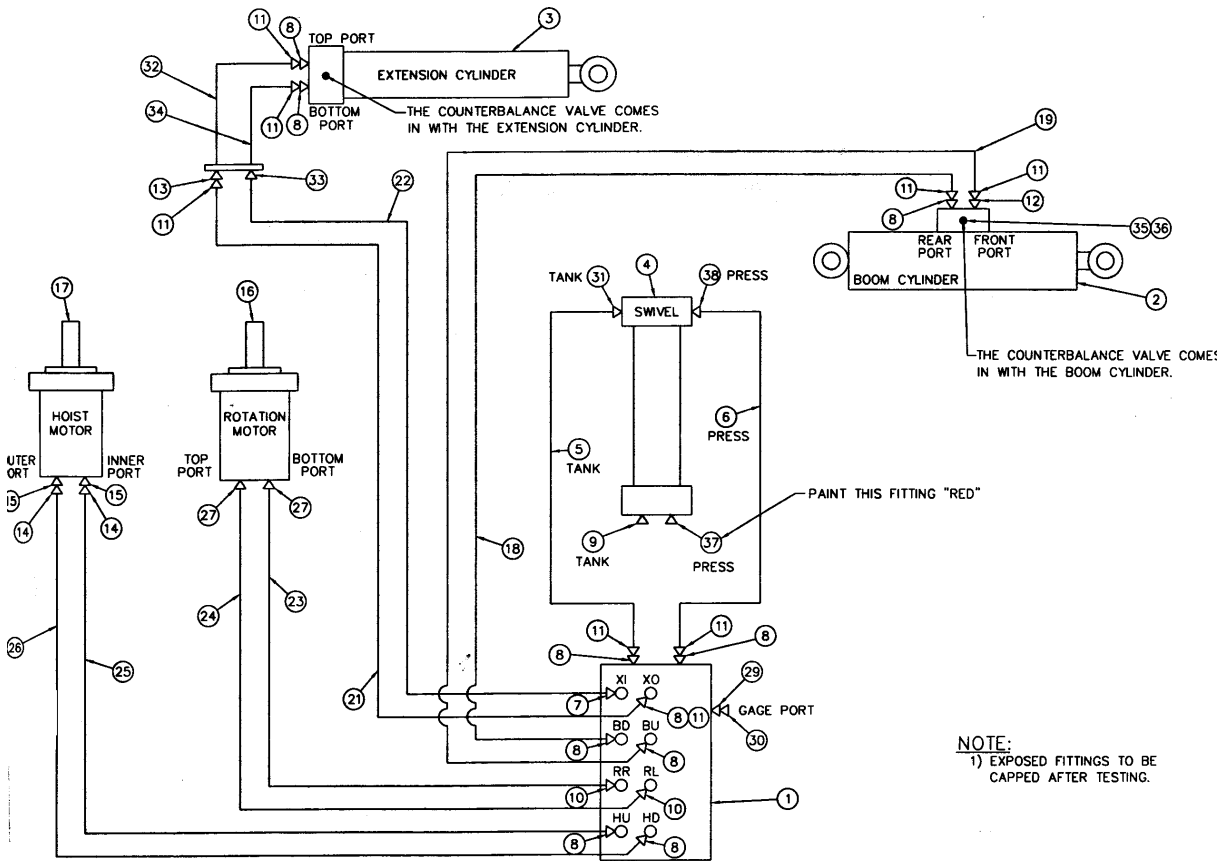

NOTE:
1) EXPOSED FITTINGS TO BE CAPPED AFTER TESTING.

NOTE:
METAL STAMP VALVE BANK IDENTIFICATION AS SHOWN

HYDRAULIC ASSEMBLY

P/N 320708 - 3203H SERIES

<u>ITEM</u>	<u>QTY</u>	<u>P/N</u>	<u>DESCRIPTION</u>
1	1	REF	HYD MANIFOLD ASSY (<i>not included</i>) (320725)
2	1	REF	BOOM CYLINDER (<i>not included</i>) (320712)
3	1	REF	EXTENSION CYLINDER (<i>not included</i>) (320713)
4	1	REF	HYDRAULIC SWIVEL (<i>not included</i>) (320714)
5	1	REF	TUBE ASSEMBLY (320731)
6	1	REF	TUBE ASSEMBLY (320732)
7	1	REF	90° ELBOW -60RM/-6JIC (241175)
8	10	REF	ADAPTER -6 ORM/-6 JICM (200876)
9	1	REF	ADAPTER -8 JICM / -6 ORM (320799)
10	2	REF	ADAPTER -6 ORM/-4 JICM (759138)
11	8	REF	90° ELBOW -6 JIC SWIVEL (480194)
12	1	REF	LONG ADAPTER -6 ORM/-6 JICM (320737)
13	1	REF	BULKHEAD UNION -6 JICM (320734)
14	2	REF	45° ELBOW -6 JIC SWIVEL (330647)
15	2	REF	ADAPTER -10 ORM/-6 JICM (320738)
16	1	REF	ROTATION MOTOR (<i>not included</i>) (320740)
17	1	REF	HOIST MOTOR (<i>not included</i>) (320741)
18	1	REF	HOSE ASSEMBLY -6 x 36" (812209036)
19	1	REF	HOSE ASSEMBLY -6 x 39" (812206039)
20	1	REF	TUBE ASSEMBLY (480188)
21	1	REF	TUBE ASSEMBLY (320770)
22	1	REF	TUBE ASSEMBLY (320769)
23	1	REF	TUBE ASSEMBLY (320771)
24	1	REF	TUBE ASSEMBLY (320772)
25	1	REF	HOSE ASSEMBLY -6 x 25" (812209025)
26	1	REF	HOSE ASSEMBLY -6 x 27" (812209027)
27	2	REF	ADAPTER -10 ORM/-4 JICM (320756)
28	2	REF	45° ELBOW -4 JIC SWIVEL (320758)
29	1	REF	ADAPTER -4 ORM/-4 JICM (320757)
30	1	REF	CAP -4 JIC (330348)
31	2	REF	45° ELBOW -6 ORM/-6 JICM (480195)
32	1	REF	HOSE ASSEMBLY -6 x 38" (812203038)
33	1	REF	ADAPTER BLKHD 90° UNION / #6 JIC (367136)
34	1	REF	HOSE ASSEMBLY -6 x 39" (320466)
35	1	REF	LOAD SENSOR ASSY (366032)
36	1	REF	LOAD SENSOR ASSY (320543)
37	1	REF	ADPTR - 6 JIC / -4 ORM
38	1	REF	ADPTR 90° -6 JIC / -4 ORM

HYDRAULIC MANIFOLD SCHEMATIC

3203H SERIES

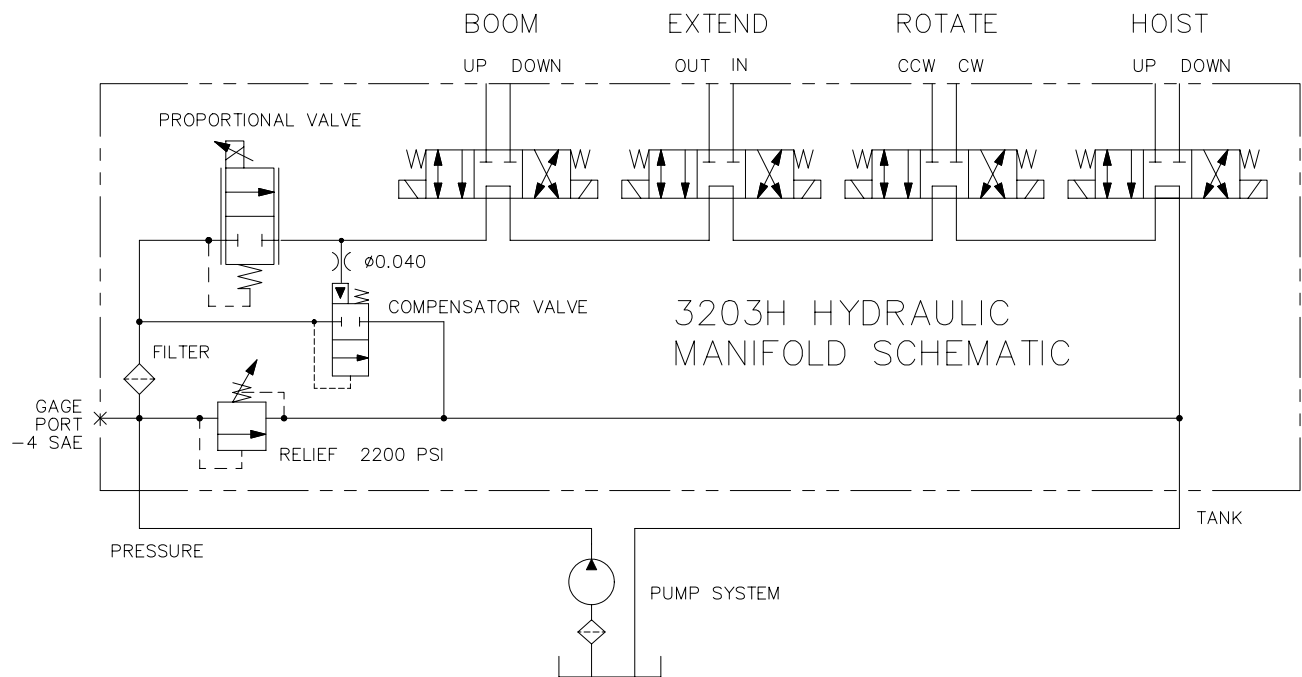

3203H TROUBLESHOOTING GUIDE

1 CRANE FAILS TO OPERATE (ALL FUNCTIONS)

- A.** Make sure power switch is set to the "on" position on the pendant.
- B.** Check power to crane by checking for truck voltage at terminal #11 on terminal strip. white harness wire.
 - 1. If truck voltage, then go to C.
 - 2. If not check continuity back to battery.
- C.** If there is power at terminal #11 and no functions are operable, find proportional valve on the right side of the hydraulic assembly and screw the manual override clockwise to provide flow to manifold. operate a function with the manual override (push or pull).
 - 1. If that function operates properly, then the problem is in the control circuit power wire (pendant or receptacle). Go to D.
 - 2. If that function does not operate properly, go to E.
- D.** Electrical problem solutions: pick a specific function and check voltage at the terminal strip by energizing that function using the pendant switch.
 - 1. If voltage is present, then check the ground circuit for continuity.
 - 2. If voltage is not present, then check pendant and harness wiring for a break in the white power wire or the colored function wire.
- E.** Hydraulic problem solutions:
 - 1. Make sure the PTO and/or the flow control device(s) are engaged and operable. Noise in pump system or excessive heat in the hydraulic system may indicate a worn or broken pump.

- 2. Check the compensator valve for contamination.

2 HOIST UP, BOOM DOWN, AND EXTEND (OUT) DON'T OPERATE (ALL OTHER FUNCTIONS DO OPERATE). THESE THREE FUNCTIONS ARE TIED INTO THE ANTI-TWO BLOCK AND CRANE OVERLOAD SENSOR SYSTEMS. THE CRANE IS SHUT DOWN WHEN THE SENSORS OPEN THE GROUND CIRCUIT FROM THE FUNCTIONS.

- A.** Unplug the anti-two-block system and reconnect din connectors to allow overload system to function (as shown in the manual).
 - 1. If the three functions work, go to B.
 - 2. If the three functions do not work, go to C.
- B.** With anti-two-block reconnected, check anti-two-block bail and switch at end of boom to verify they move freely. Switch should make audible click when operated. Try operating crane while pulling cord out of cord reel to check for possible bad spots in cord reel slip rings. Check cord for breaks. A ohmmeter can be used on the two din connectors to test this system while it is unplugged. The system is normally open.
- C.** Check load sensor pressure switch by unplugging the din connector and checking for a closed circuit.
 - 1. If circuit is closed and boom is unloaded, replace switch and reconnect anti-two-block circuit.
 - 2. If circuit is open, go to D.

3203H TROUBLESHOOTING GUIDE

CAUTION: BE SURE BOOM IS SUPPORTED BEFORE REMOVING SWITCH OR BOOM WILL FALL.

3. Load Sensor(Pressure Switch)

A. With crane unloaded, unplug weather pack connector on load sensor wire.

- D.** If the three functions work, check both Pressure Switch's by taking a ohm reading on the two wires coming from each individual switch. The 2,350 psi switch (P/N 320543) has normal open contacts, so the reading should be the minimum ("open"). If greater than maximum ohm reading is indicated (usually a dead short) replace the switch. The 2,500 psi switch (P/N 366032) has normally closed contacts, so the reading should be maximum. If less than the maximum ohm reading is indicated (usually an "open") replace the switch.
- E.** If the functions do not work, continue with section #3.
- F.** Locate timing relay box on back of crane and open lid. Disconnect yellow wire on terminal #1 of the time delay relay.
- 1.** If the three functions do not work, check the ground for overload system through the relay. (The relay may be operated by touching the yellow wire to any ground.)
 - 2.** If three functions work, clean terminals #6 and #7 on time delay relay, reconnect yellow wire to #1 terminal and retry the three functions.
 - i.** If the three functions still do not work, replace the time delay relay.

- ii.** If the three functions work, spray the terminals with a protective coating and keep them clean.
- 3.** The time delay relay may be operated by removing the connectors from terminals #6 and #7 and shorting the two terminals with a jumper. The interval between make and brake is approximately $\frac{3}{4}$ second.

CAUTION: CONNECTING THE POWER TERMINAL #3 TO TERMINAL #6 MAY CAUSE RELAY FAILURE.

3 SINGLE HYDRAULIC FUNCTION DOES NOT WORK.

- A.** With trigger pulled, operate the function using the manual override.
- 1.** If it works, check power and ground going to coil at weather pack connector.
 - 1.** Verify ground circuit.
 - i.** Verify function power circuit.
 - 2.** If it does not work, then remove valve, clean and inspect it.
 - 3.** If it still does not work, then check cylinder or motor and connecting hoses for obstructions or failure.
- B.** Test the proportional activation system also by operating the proportional manual override screw instead of the trigger on the pendant. *Be sure to restore the override to the full out position before using the crane.*
- C.** If boom retract or boom down functions don't work, then check for low hydraulic pressure at pump. These two functions have the highest pressure requirements for

3203H TROUBLESHOOTING GUIDE

an unloaded crane because they must overcome the pressure settings of the counter balance valves.

- D.** If hydraulic functions are more intermittent when cylinders are extended, then check hydraulic fluid level.
- E.** Boom locks up and won't come down when fully raised - this is caused by having the

pump relief pressure higher than the pressure that causes the overload system to activate. Set relief pressure to the correct setting of 2200 psi. Unlock boom by using the manual override of the boom down function. If pressure is correct and problem continues, then replace overload pressure switch.

COUNTERBALANCE VALVE SETTING

3203H SERIES

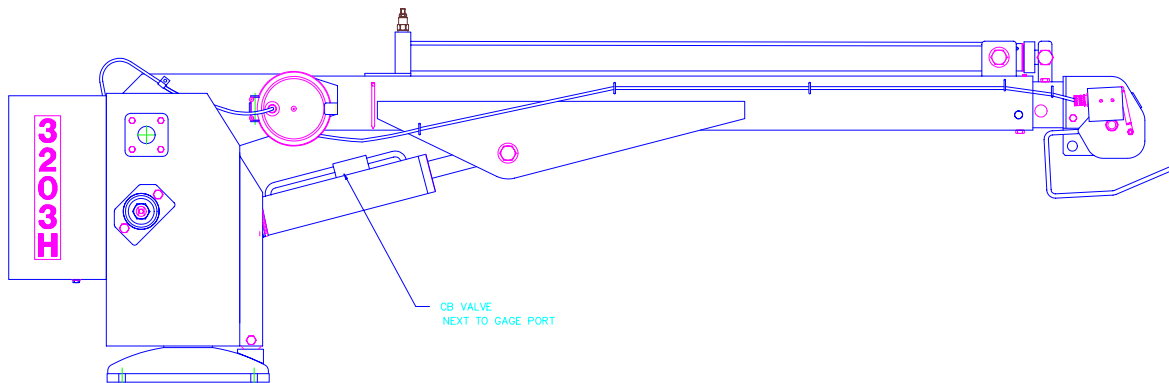

CAUTION:

IF COUNTERBALANCE VALVE IS REPLACED, THE CORRECT PRESSURE SETTING MUST BE MADE BEFORE CRANE IS IN SAFE WORKING CONDITION.

IMPORTANT

Crane boom must be supported and pump system disengaged during the removal and installation of the pressure gage port plug, pressure gage, pressure switch and counterbalance valve.

Valve Setting

To set counterbalance valve:

1. With boom supported, remove -6 ORP plug on cylinder block next to valve and install a pressure gauge; 2500 psi capacity minimum.
2. Boom up until boom cylinder is fully elevated.
3. Boom down in small increments while reading pressure gauge.
4. Loosen the 9/16" nut on end of valve, adjust 5/32" Allen screw and then retighten nut. Repeat procedure until pressure reading is a constant 900 psi. If valve is not set and boom reaches the full down position, boom up and keep trying.
5. Support boom, remove gauge and replace plug when adjustment is complete.

STABILIZER ASSEMBLY

P/N 360300 - 3203H SERIES

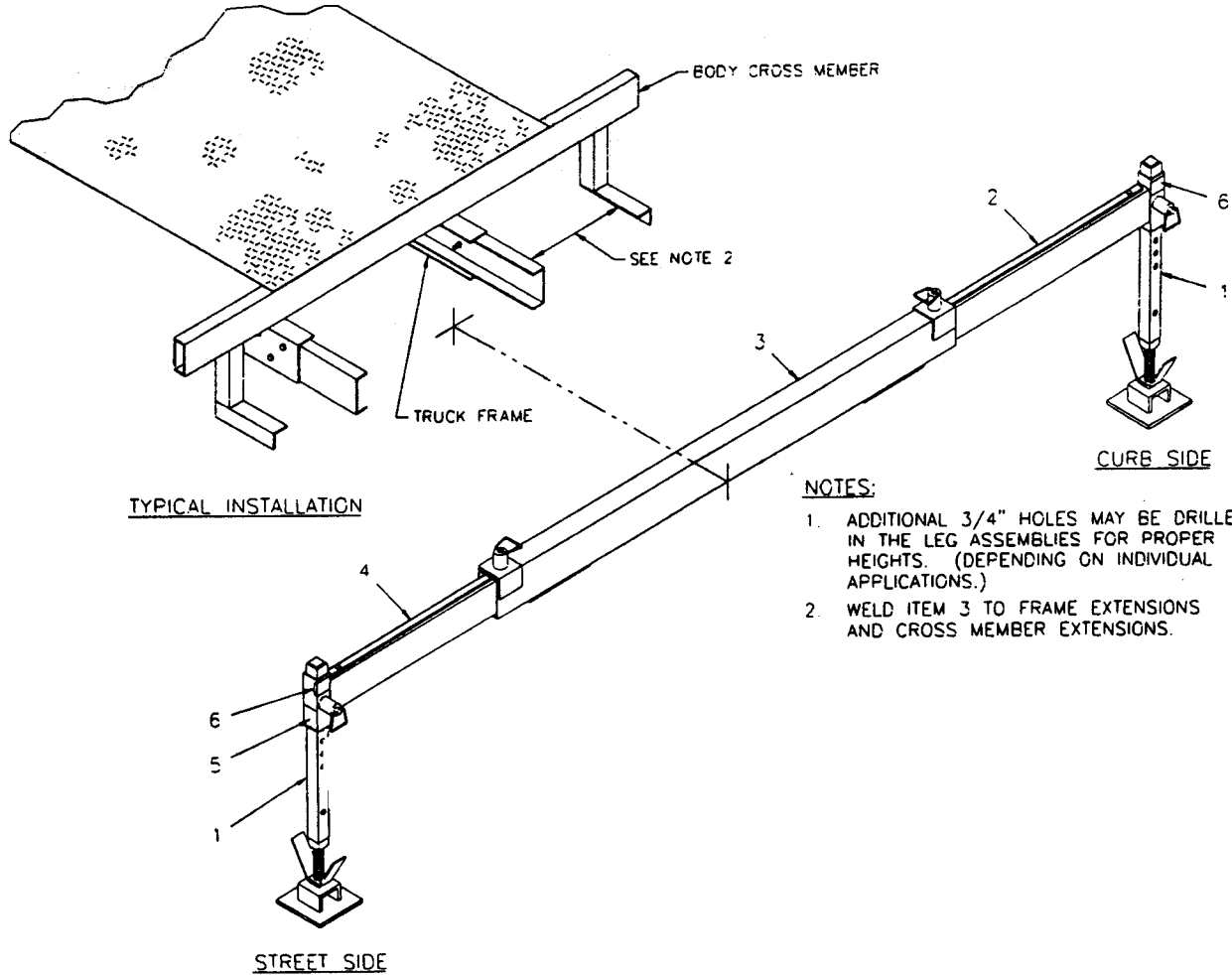

- NOTES:**
1. ADDITIONAL 3/4" HOLES MAY BE DRILLED IN THE LEG ASSEMBLIES FOR PROPER HEIGHTS. (DEPENDING ON INDIVIDUAL APPLICATIONS.)
 2. WELD ITEM 3 TO FRAME EXTENSIONS AND CROSS MEMBER EXTENSIONS.

<u>ITEM</u>	<u>QTY</u>	<u>P/N</u>	<u>DESCRIPTION</u>
1	2	360301	LEG ASSEMBLY
2	1	360302	SOCKET / PULL PIN ASSEMBLY
3	1	360303-001	OR SOCKET / PULL PIN ASSEMBLY
4	1	360325	SOCKET / PULL PIN ASSEMBLY
5	2	040581	DANGER CRUSHING DECAL
6	2	759017	CAUTION DECAL

STABILIZER ASSEMBLY

P/N 725570 - 3203H SERIES

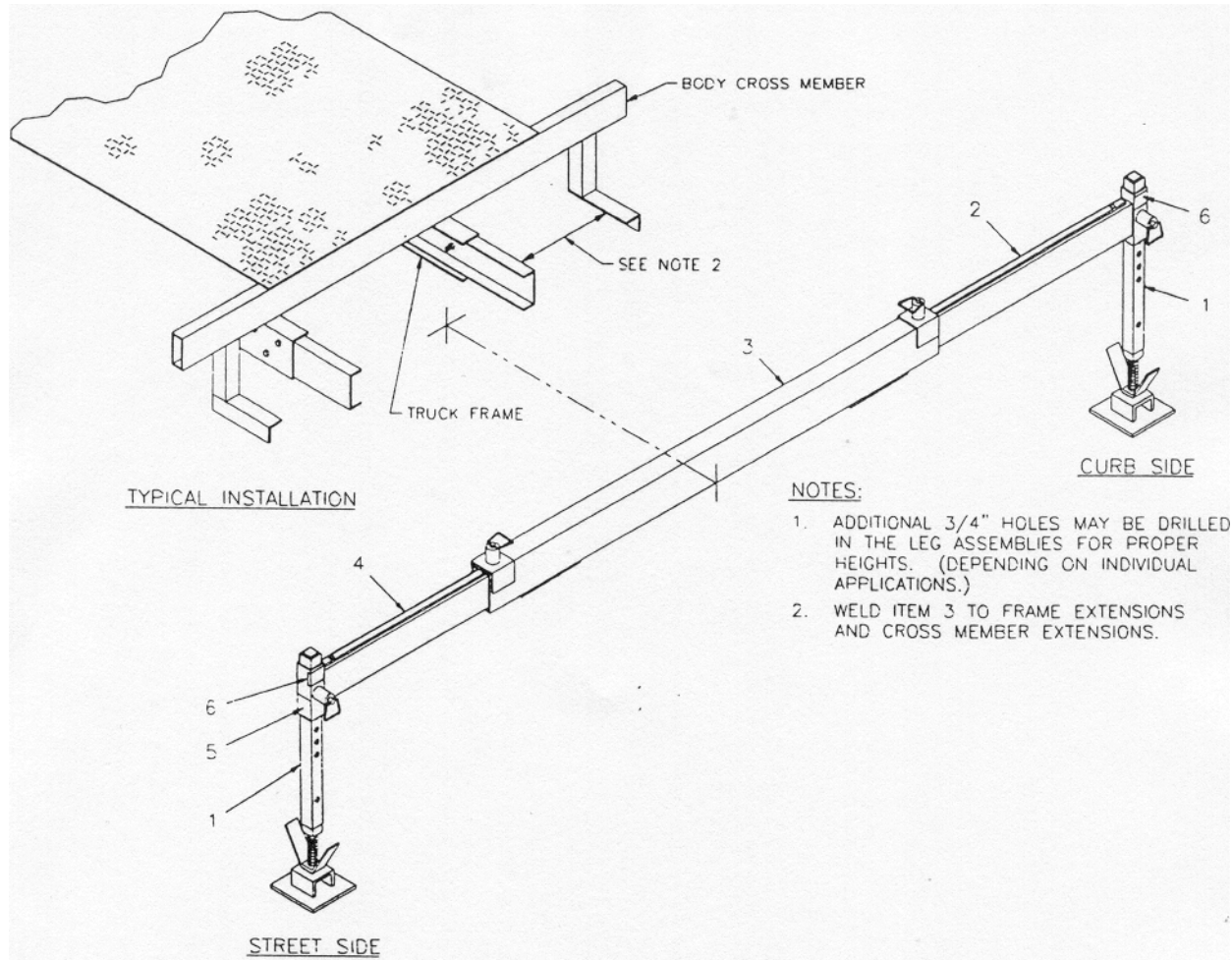

- NOTES:**
1. ADDITIONAL 3/4" HOLES MAY BE DRILLED IN THE LEG ASSEMBLIES FOR PROPER HEIGHTS. (DEPENDING ON INDIVIDUAL APPLICATIONS.)
 2. WELD ITEM 3 TO FRAME EXTENSIONS AND CROSS MEMBER EXTENSIONS.

<u>ITEM</u>	<u>QTY</u>	<u>P/N</u>	<u>DESCRIPTION</u>
1	2	360301	LEG ASSEMBLY
2	1	725588	CURB SIDE SOCKET / PULL PIN ASSEMBLY
3	1	360303-001	OR SOCKET / PULL PIN ASSEMBLY
4	1	725589	STREET SIDE SOCKET / PULL PIN ASSEMBLY
5	2	040581	DANGER CRUSHING DECAL
6	2	759017	CAUTION DECAL

STABILIZER ASSEMBLY W/CRANKDOWN LEGS

P/N 725572 - 3203H SERIES

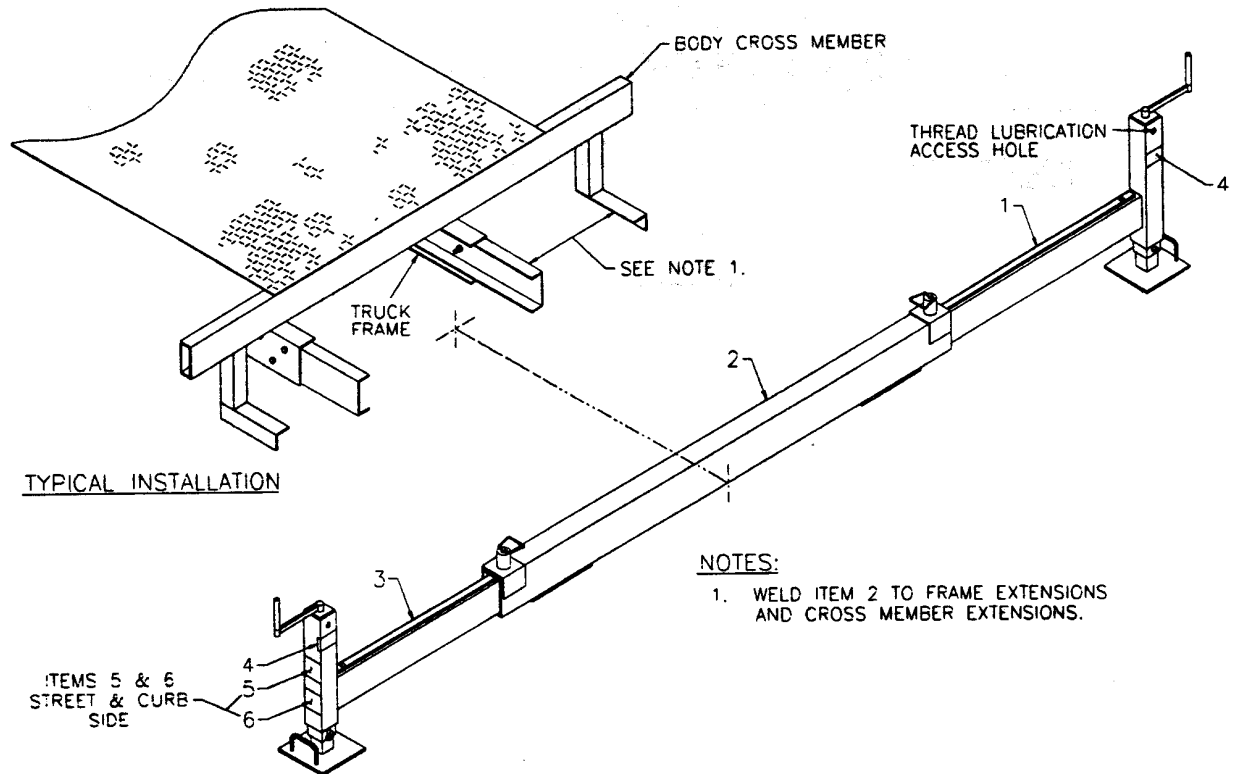

ITEM	QTY	P/N	DESCRIPTION
1	1	725592	CURB SIDE LEG ASSEMBLY
2	1	360303-001	OR SOCKET / PULL PIN ASSEMBLY
3	1	725593	STREET SIDE LEG ASSEMBLY
4	2	759017	CAUTION DECAL
5	2	725962	DANGER DECAL
6	2	040581	DANGER CRUSHING DECAL

MANUAL OUTRIGGER W/CRANKDOWN LEG ASSEMBLY

P/N 725562 - 3203H SERIES

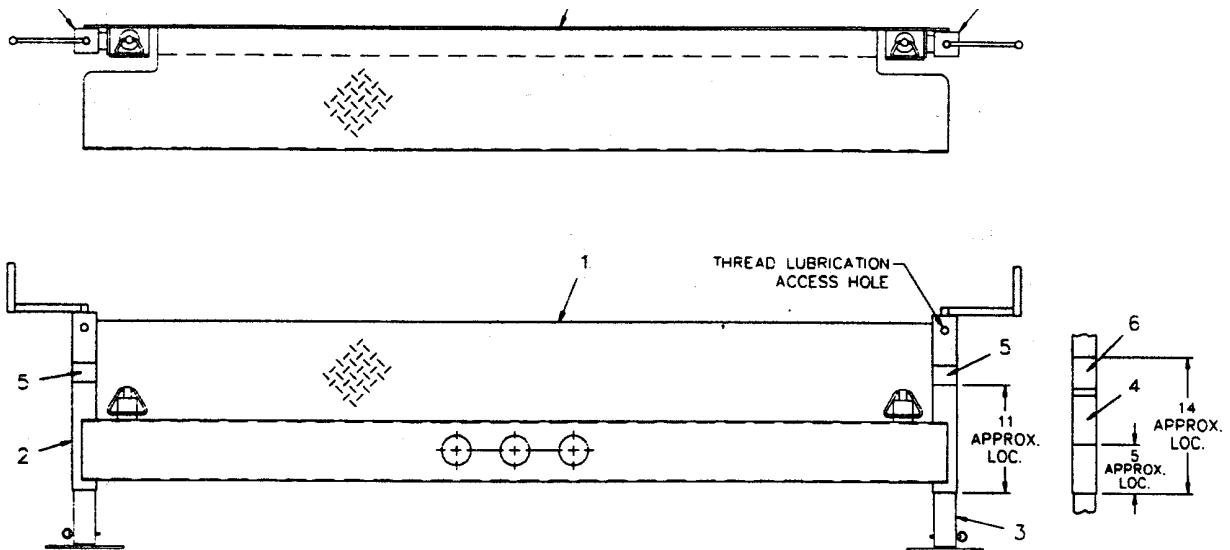

<u>ITEM</u>	<u>QTY</u>	<u>P/N</u>	<u>DESCRIPTION</u>
1	1	725200	WELDMENT BUMPER
2	1	725593	STREET SIDE SLIDE w/ CRANKDOWN LEG
3	1	725592	CURB SIDE SLIDE w/ CRANKDOWN LEG
4	2	040581	DANGER CRUSHING DECAL
5	2	040581	CAUTION DECAL
6	2	040581	DANGER DECAL

LOAD CHART

3203H SERIES

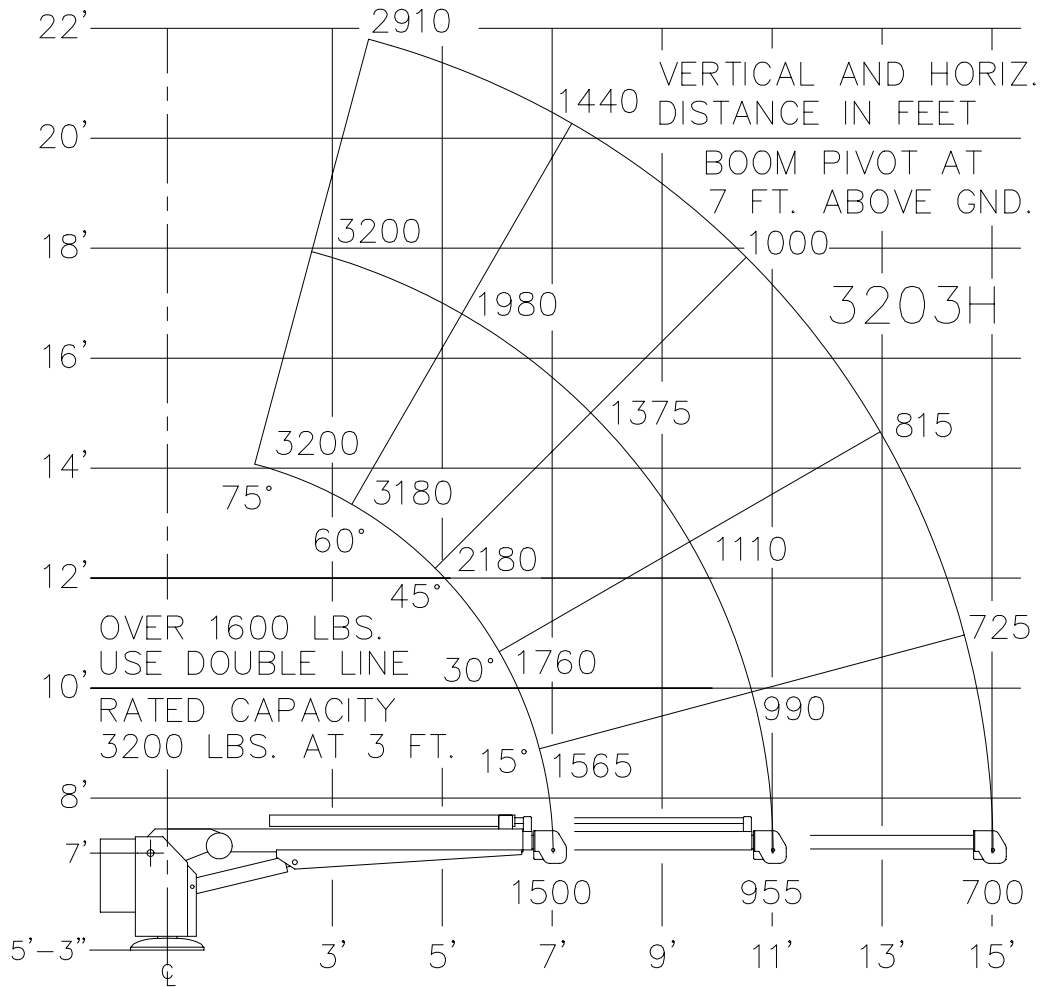



P.O. Box 580697 * Tulsa, OK 74158-0697
4707 N. Mingo Rd. * Phone (918) 836-0463

LIMITED WARRANTY 2 YEAR PARTS AND LABOR

Auto Crane will warranty to the consumer for a period of (2) years parts and labor from the date of purchase. Each new Auto Crane unit they sell will be free under normal use and service from defects in material and workmanship. Date of purchase will be honored as the date indicated on the Bill of Sale, which must accompany the Warranty Registration and be on file with Auto Crane. Absent a valid Warranty Registration and appropriate documentation, the original date of manufacture, as indicated by the serial number on the product, will be used to determine the effective date of the 2 year warranty.

The obligation of Auto Crane under this warranty is limited to the replacement or repair of parts that appear to the manufacturer after review and/or inspection to be defective and paid flat rate labor for replacing defective parts. This warranty does not obligate Auto Crane to bear the travel time charges in connection with the replacement or repair of defective parts. Responsibility for customer's claims arising from misapplication, abuse, misuse or alteration of equipment or parts lies with the distributor or user and no warranty obligation is assumed in these circumstances by Auto Crane.

Auto Crane will in no event be liable for any consequential damages or contingent liabilities arising out of the failure of any Auto Crane Product or parts to operate properly.

Auto Crane makes no warranty in respect to component accessories, it being subject to the warranties of their respective manufacturers.

If field service, at the request of the distributor, is rendered and fault is found not to be with Auto Crane's product, the distributor shall pay the time and expense of the field representative.

Claims for service labor or other expenses that have incurred by the buyer without approval or authorization or Auto Crane will not be accepted.

When applying for warranty, claims may be handled by contacting your nearest authorized Auto Crane Distributor. All claims are to be filed in writing on an Auto Crane Warranty Claim Form.

AUTO CRANE COMPANY IS UNDER NO OLIGATION TO EXTEND THIS WARRANTY TO ANY CUSTOMER FOR WHICH AN AUTO CRANE DELIVERY REPORT FORM HAS NOT BEEN COMPLETED AND ON FILE WITH AUTO CRANE COMPANY