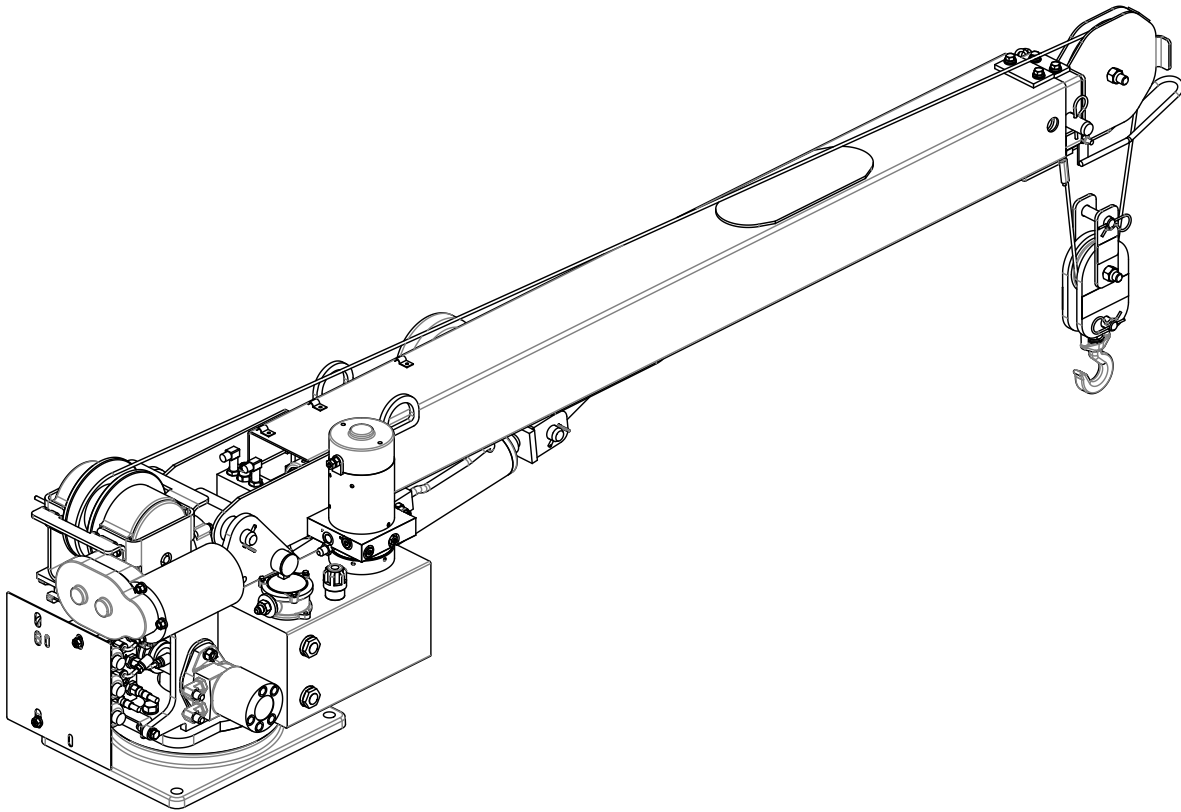




3203 PR/PRX/PREF OWNERS MANUAL



Serial No. _____

Mailing Address:
P.O. Box 580697 Tulsa,
OK 74158-0697 Physical
Address: 4707 N. Mingo
Rd. Tulsa, OK 74117-5904

Phone 1-800-777-2760
Fax (918) 269-6688
<http://www.autocrane.com>



Auto Crane Registration

From: _____ Date: _____

End User Information:

Company: _____ Phone: _____

Address: _____

City: _____ State: _____ Zip: _____

Contact: _____ E-mail: _____

Distributor Information:

Company: _____ Phone: _____

Address: _____

City: _____ State: _____ Zip: _____

Contact: _____ E-mail: _____

Product Information:

Model No: _____ Serial No: _____ Date Delivered: _____

VIN #: _____

ONE REGISTRATION FORM PER UNIT (CRANE, BODY, OR COMPRESSOR)

Please submit form within 15 days after installation

Online: www.autocrane.com | Resources | Warranties

Fax: 918-234-2177

Mail: Product Registration, Auto Crane Company, PO Box 580697, Tulsa, OK 74158-0697

WARNINGS

WARNING! Federal law (49 cfr part 571) requires that the Final Stage Manufacturer of a vehicle certify that the vehicle complies with all applicable federal regulations. Any modifications performed on the vehicle prior to the final state are also considered intermediate stage manufacturing and must be certified as to compliance. The installer of this crane and body is considered one of the manufacturers of the vehicle. As such a manufacturer, the installer is responsible for compliance with all applicable federal and state regulations, and is required to certify that the vehicle is in compliance.

WARNING! It is the further responsibility of the installer to comply with the OSHA Truck Crane Stability Requirements as specified by 29 CFR part 1910.180 (C) (1).

WARNING! NEVER OPERATE THE CRANE NEAR ELECTRICAL POWER LINES! Death or serious injury will result from boom, line, or load contacting electric lines. Do not use crane within 10 feet (3.05m) of electric power lines carrying up to 50,000 volts. One-foot additional clearance is required for every additional 30,000 volts or less. SEE DANGER DECAL (P/N 040529) in this Owner's Manual.

WARNING! NEVER.....

- ◆ **EXCEED load chart capacities (centerline of rotation to hoist hook).**
- ◆ **Un-reel last 5 wraps of cable from drum!**
- ◆ **Wrap cable around load!**
- ◆ **Attempt to lift or drag a load from the side! The boom can fail far below its rated capacity.**
- ◆ **Weld, modify, or use unauthorized components on any Auto Crane unit! This will void any warranty or liability. Also failure of the crane may result.**
- ◆ **Place a chain link on the tip of the hook and try to lift a load!**
- ◆ **Use a sling bar or anything larger than the hook throat that could prevent the hook latch from closing, thus negating the safety feature!**
- ◆ **Hold on any pendant Select Switch that will cause unsafe operating conditions!**

WARNING! In using a hook with latch, ALWAYS make sure that the hook throat is closed before lifting a load! Proper attention and common sense applied to the use of the hoist hook and various slings will prevent possible damage to material being hoisted and may prevent injury to personnel.

WARNING! Failure to correctly plumb and wire crane can cause inadvertent operation and damage to crane and/or personnel!

WARNING! Auto Crane Company remote controlled cranes are not designed or intended for use for any applications involving the lifting or moving of personnel.

WARNING! ALWAYS operate the crane in compliance with the load capacity chart. DO NOT USE the overload shutdown device to determine maximum rated loads, if the crane is equipped with this type of device.

READ THIS PAGE

3203 PR/PRX/PRFX

TABLE OF CONTENTS

INTRODUCTION	1
GENERAL SPECIFICATIONS	3
SAFETY TIPS AND PRECAUTIONS	4
OPERATING PRACTICES & WARNINGS	6
QUALIFICATIONS FOR OPERATORS	7
OPERATION OF UNIT / OUTRIGGERS	11
INSPECTION	12
TESTING	15
MAINTENANCE	16
BATTERIES	18
LUBRICATION AND MAINTENANCE SCHEDULE	20
SINGLE LINE PROCEDURE	22
ROTATION BEARING REPLACEMENT	23
SAFETY DECAL SECTION	24
GENERAL DIMENSIONS	31
MOUNTING AND INSTALLATION	32
GENERAL ASSEMBLY, HARDWIRED	34
PEDESTAL ASSEMBLY	40
BOOM ASSEMBLY	52
HOIST ASSEMBLY	49
TRAVELING BLOCK ASSEMBLY	63
RELAY PANEL ASSEMBLY	65
ELECTRICAL SECTION, HARDWIRED	66
PENDANT ASSEMBLY	68
TWECO W/SWITCH MOUNT	71
HYDRAULIC SECTION	72
POWER UNIT	75
GENERAL ASSEMBLY, FM	76
FM CONTROL USE & CARE	82
TRANSMITTER ASSEMBLY, FM	83
ELECTRICAL SECTION, FM	85
FM, DIAGNOSTICS, TROUBLESHOOTING, AND ID PROG.	86
LOAD CHART	95
WARRANTY	LAST 2 PAGES

3203PR/PRX INTRODUCTION

Auto Crane products are designed to provide many years of safe, trouble-free, dependable service when properly used and maintained.

To assist you in obtaining the best service from your crane and to avoid untimely crane and/or vehicle failure, this manual provides the following operating and service instructions. It is specifically recommended that all operating and service personnel consider this manual as mandatory material for reading and study before operating or servicing Auto Crane products. It is highly recommended that crane owners, equipment managers, and supervisors also read this manual.

Auto Crane has incorporated several safety features in the 3203 PR/PRX crane for your protection.

For your convenience the overall dimensions of the 3203 PR/PRX crane are included on the General Dimension Drawing. Rotation and turning radius are also listed on that drawing.

Remember, the crane adds weight to the vehicle. Adding weight may change the driving and riding characteristics of the vehicle unless the appropriate overload spring(s) are installed on the truck. The payload of the vehicle is reduced by the weight of the crane. The operator should exercise care when loading the vehicle. Distributing the payload on the vehicle evenly will greatly improve the driving and riding characteristics of the vehicle.

Auto Crane Company issues a limited warranty certificate with each unit sold. See last page for warranty.

The 3203 PR/PRX cranes are attached to your truck electrical system through the Main Power Switch provided. The 3203 PR/PRX is another highly efficient Auto Crane product. The use of a maintenance-free battery is not recommended on any Auto Crane product. The recommended alternator and battery

that will give the longest life with the most useful duty cycle is a 125-amp alternator with a 500 cold cranking amp battery. These specifications should be considered minimum.

It has always been Auto Crane Company policy to handle all warranty claims we receive as promptly as possible. If a warranty claim involves discrepant material or workmanship, Auto Crane will take immediate corrective action. It is understandable that Auto Crane Company cannot assume responsibility of liability when it is obvious that our products have been abused, misused, overloaded or otherwise damaged by inexperienced persons trying to operate the equipment without reading the manual.

Auto Crane will not assume responsibility or liability for any modifications or changes made to unit, or installation of component parts without authorization.

Auto Crane maintains a strong distributor network and a knowledgeable Customer Service Department. In most cases, an equipment problem is solved via phone conversation with our customer service department. The customer service department also has the ability to bring a local distributor, a regional sales manager, or a factory serviceman into the solution of an equipment problem.

If, through no fault of Auto Crane Company, it is necessary to send an experienced factory serviceman on a field service call the rates stated in the Auto Crane Distributor's Flat Rate Manual will apply.

Auto Crane Company's extensive Research and Development Program allow our customers to use the best equipment on the market. Our Engineering Staff and our knowledgeable sales people are always available to our customers in solving crane and winch-type application problems. When in doubt, call the Auto Crane factory.

Note: This manual should remain with the crane at all times.

3203PR/PRX INTRODUCTION

DISTRIBUTOR ASSISTANCE:

Should you require any assistance not given in this manual, we recommend that you consult your nearest Auto Crane Distributor. Our distributors sell authorized parts and have service departments that can solve almost any needed repair. This manual does not cover all maintenance, operating, or repair instructions pertinent to all possible situations. If you require additional information, please contact the Auto Crane Company at the following telephone number: (918) 836-0463. The information contained in the manual is in effect at the time of this printing. Auto Crane Company reserves the right to update this material without notice or obligation.

3203PR/PRX

GENERAL SPECIFICATIONS

DIMENSIONS

Width: 21 in (0.53 m)
 Height: 24.00 in (0.61 m)
 Length: 9 ft 1-1/2 in (2.78 m)
 [boom(s) stored]
 Weight: 860 lbs (390kg)

CAPACITY

10,000 ft-lbs (1.38 tt-m)
 [ft-lbs = horizontal distance from centerline of rotation to free hanging weight (feet) x amount of weight (pounds)]

LIFTING CAPACITIES			
ft	lbs	ft	lbs
2	3,200	9	1,100
3	3,200	10	1,000
4	2,500	11	900
5	2,000	12	830
6	1,670	13	770
7	1,500	14	710
8	1,250	15	660

REACH

Second boom will reach from 7 feet 4 inches to 11 feet 4 inches.
 Third boom will reach from 11 feet 4 inches to 15 feet 4 inches.

CABLE

62 ft (18.9) of 7/32 in (5.56 mm) diameter aircraft quality cable. This cable has a single line breaking strength of 5,600 lbs (2,540 kg).

CHASSIS REQUIREMENTS

201,600 in-lbs (22,777 Nm) RBR minimum
 8,800 LBS (3,992 kg.) GVWR minimum

ELECTRICAL SYSTEM REQUIREMENTS

Voltage: 12 VDC
Alternator: 125 amp (minimum)
Battery: 130 minute reserve capacity (minimum)

Maintenance type

ROTATION

360° Continuous

TANK OIL CAPACITY

2.4 GALLONS (9.08 LITERS)

--- IMPORTANT ---

SAFETY TIPS AND PRECAUTIONS

1. No unqualified or unauthorized person shall be allowed to operate the crane.
2. WARNING: Never weld, modify, or use unauthorized components / parts on any Auto Crane unit. This will void any warranty or liability. Also, failure of the crane may result.
3. Make certain the vehicle meets minimum chassis requirements. (These requirements do not guarantee unit stability.)
4. Make certain the crane is installed per factory specifications. Contact your local distributor or the Auto Crane factory if any questions arise.
5. Visual inspections and tests should be conducted at the beginning of each shift each day to insure that the crane and all its operating systems are in good condition and working order before it is used.
6. Inspect hydraulic hoses frequently for signs of deterioration, and replace them as required.
7. If a hydraulic break occurs, leave the area of the break and do not attempt to stop the break by hand as the hydraulic oil may be hot and under high pressure which can cause serious injury. Shut the system down as soon as possible.
8. Check the hook at least every thirty days for distortions or cracks and replace it as required.
9. Oil gears as required.
10. Stop all operations when cleaning, adjusting or lubricating the machine.
11. Keep dirt and grit out of moving parts by keeping crane clean. Make sure machine is free of excess oil, grease, mud and rubbish, thus reducing accidents and fire hazards.
12. When a new cable is installed, operate first with a light load to let the cable adjust itself.
13. Locate the vehicle at the work site for the best stability possible.
14. Keep the vehicle in a level position while loading or unloading.
15. Observe operating area for obstructions and/or power lines that might be a hazard.
16. WARNING: NEVER OPERATE THE CRANE NEAR ELECTRICAL POWER LINES. Auto Crane Company recommends that the crane never be any closer to a power line (including telephone lines) than 10 feet at any point.
17. Allow the vehicle engine to warm up before operating crane.
18. Know the weight of your rigging and load to avoid overloading the crane.
19. Deduct the weight of the load handling equipment from the load rating to determine how much weight can be lifted.
20. All load ratings are based on crane capacity, NOT the vehicle stability. Remember in lifting a heavy load, the weight can create enough tipping moment to overturn the vehicle
21. Always comply with load chart capacities, (centerline of rotation to hook).
22. Secure all loads before lifting.
23. Always set the emergency brake before beginning operation.
24. Keep objects and personnel clear of crane path during operation.
25. Operate control levers slowly and smoothly in order to meter oil flow for safe operation. (Not applicable to electric-hydraulic cranes.)
26. Always extend the outriggers from vehicle to the ground before crane operation. Insure that they are firmly positioned on solid footings. Stand clear of outriggers while they are being extended.
27. If any outrigger, when extended, rests on a curb or other object that prevents it from extending to its maximum distance, shorten bearing or fulcrum point and reduce the maximum load accordingly.
28. When an outrigger will not reach the ground due to holes or grades, it shall be blocked up to provide level and firm support for the truck.
29. When working in soft earth, use wide pads under outrigger feet to prevent sinking.
30. Always store outriggers before transportation.

WARNING!

Auto Crane Company cranes are not designed or intended for use in lifting or moving persons. Any such use shall be considered to be improper and the seller shall not be responsible for any claims arising there from. This sale is made with the express understanding that there is no warranty that the goods shall be fit for the purpose of lifting or moving persons or other improper use and there is no implied warranty or responsibility for such purposes.

--- IMPORTANT ---

SAFETY TIPS AND PRECAUTIONS

31. Always store the crane in its stowed position for transportation.
 32. Remember the overall height of the entire unit for garage door clearance or when moving under objects with low overhead clearance
 33. Disengage power takeoff (PTO) before moving the vehicle.
(Not applicable to electric-hydraulic cranes.)
 34. Always walk around the vehicle before moving.
 35. Never drive with a load suspended from crane.
 36. Do not take your eyes off a moving load. Look in the direction you are moving.
 37. Never swing a load over people.
 38. Do not stop the load sharply in midair so that it swings like a pendulum. Meter the control levers to avoid this situation.
(Not applicable to electric-hydraulic cranes.)
 39. Crane boom length should be kept as short as possible for maximum lifting capacity and greater safety. Longer booms require additional care in accelerating and decelerating the swing motion, and thus slow down the working cycle and reduce productivity.
 40. Keep the load directly and vertically under the boom point at all times. Crane booms are designed to handle vertical loads, not side lifts.
- WARNING: Never attempt to lift, drag, tow or pull a load from the side. The boom can fail far below its rated capacity.
41. Do not push down on anything with boom extensions; similarly do not lift anything with boom extensions.
 42. Do not lift personnel with any wire rope attachment or hook. There is no implied warranty or responsibility for such purposes.
 43. WARNING: In using a safety hook, ALWAYS close the hook throat before lifting a load. Proper attention and common sense applied to the use of the hook and various slings will prevent possible damage to material being hoisted and may prevent injury to personnel.
 44. WARNING: Never place a chain link on the tip of the hook and try to lift a load with the hoist.
 45. WARNING: Never use a sling bar or anything larger than the hook throat which could prevent the safety latch from closing, thus negating the safety feature.
 46. Do not wrap the wire rope around sharp objects when using winch.
 47. WARNING: Never unreel last 5 wraps of cable from drum.

--- IMPORTANT ---

OPERATING PRACTICES AND WARNINGS

1. Make certain the vehicle meets minimum chassis requirements. (These requirements do not guarantee unit stability)
 2. Make certain the crane is installed per factory specifications. Contact your local Distributor or the Auto Crane factory if any questions arise.
 3. Keep the vehicle in as level a position as possible while loading or unloading.
 4. ALWAYS set the vehicle emergency brake before beginning crane operations.
 5. ALWAYS use outriggers from vehicle to the ground during crane operation. Make sure they are firmly positioned on solid footings.
 6. All load ratings are based on crane capacity, NOT truck/ crane stability.
 7. Keep objects and personnel clear of crane path during operation.
 8. Keep hoist cable pulled tight at all times.
 9. REMEMBER, in lifting a heavy load, the weight can create enough tipping momentum to overturn the vehicle.
 10. ALWAYS keep load as close to ground as possible.
 11. Hydraulic hoses need to be inspected frequently for signs of deterioration, and be replaced as required.
 12. The hoist hook is an important item that an operator should consider and use properly. It should be checked on a daily basis for distortion or cracks.
 13. ALWAYS store outriggers before road travel.
 14. WARNING! NEVER OPERATE THE CRANE NEAR ELECTRICAL POWER LINES! Death or serious injury will result from boom, line, or load contacting electric lines. Do not use crane within 10 feet (3.05m) of electric power lines carrying up to 50,000 volts. One foot additional clearance is required for every additional 30,000 volts or less.
 15. WARNING! NEVER EXCEED load chart capacities (centerline of rotation to hoist hook).
 16. WARNING! NEVER un-reel last 5 wraps of cable from drum!
 17. WARNING! NEVER wrap cable around load!
 18. WARNING! NEVER attempt to lift or drag a load from the side! The boom can fail far below its rated capacity.
 19. WARNING! NEVER weld, modify, or use unauthorized components on any Auto Crane unit! This will void any warranty or liability. Also failure of the crane may result.
 20. WARNING! NEVER place a chain link on the tip of the hook and try to lift a load!
 21. WARNING! NEVER use a sling bar or anything larger than the hook throat that could prevent the hook latch from closing, thus negating the safety feature!
 22. WARNING! In using a hook with latch, ALWAYS insure that the hook throat is closed before lifting a load! Proper attention and common sense applied to the use of the hoist hook and various slings will prevent possible damage to material being hoisted and may prevent injury to personnel.
- WARNING! NEVER hold any Control Select Switch on that will cause unsafe operating conditions!

WARNING!

Auto Crane Company remote controlled, stiff boom cranes are not designed or intended for use on any applications involving the lifting or moving of personnel.

QUALIFICATIONS FOR AND CONDUCT OF OPERATORS AND OPERATING PRACTICES

REFERENCE ASME B30.5a AND OSHA 1910.180 FOR COMPLETE QUALIFICATION REQUIREMENTS

OPERATORS

1. Crane operation shall be limited to personnel with the following minimum qualifications:
 - A. Designated persons.
 - B. Trainees under the direct supervision of a designated person.
 - C. Maintenance and test personnel (when it is necessary in the performance of their duties).
 - D. Inspectors (crane).
2. No one other than the personnel specified above shall enter the operating area of a crane with the exception of persons such as oilers, supervisors, and those specified persons authorized by supervisors whose duties require them to do so and then only in the performance of their duties and with the knowledge of the operator or other persons.

QUALIFICATIONS FOR OPERATORS

1. Operators shall be required by the employer to pass a practical operating examination. Qualifications shall be limited to the specific type of equipment for which examined.
2. Operators and operator trainees shall meet the following physical qualifications:
 - A. Vision of at least 20/30 Snellen in one eye and 20/50 in the other, with or without corrective lenses.
 - B. Ability to distinguish colors, regardless of position, if color differentiation is required for operation.
 - C. Adequate hearing with or without hearing aid for the specific operation.
3. Evidence of physical defects or emotional instability, which render a hazard to operator or others, which in the opinion of the examiner could interfere with the operator's performance, may be sufficient cause for disqualification. In such cases, specialized clinical or medical judgment and tests may be required.
4. Evidence that operator is subject to seizures or loss of physical control shall be sufficient reason for disqualification. Specialized medical

tests may be required to determine these conditions.

5. Operators and operator trainees should have normal depth perception, coordination, and no tendencies to dizziness or similar undesirable characteristics.
6. In addition to the above listed requirements, the operator shall:
 - A. Demonstrate the ability to comprehend and interpret all labels, operator's manuals, safety codes, and other information pertinent to correct crane operations.
 - B. Posses the knowledge of emergency procedures and implement it.
 - C. Demonstrate to the employer the ability to operate the specific type of equipment.
 - D. Be familiar with the applicable safety regulations.
 - E. Understand the operating procedures as outlined by the manufacturer.
 - F. Be thoroughly familiar with the crane and its control functions.
 - G. Understand the operating procedures as outlined by the manufacturer.

CONDUCT OF OPERATORS

1. The operator shall not engage in any practice, which will divert his attention while actually operating the crane.
2. Each operator shall be responsible for those operations under the operator's direct control. Whenever there is any doubt as to safety, the operator shall consult with the supervisor before handling the loads.
3. The operator should not leave a suspended load unattended unless specific precautions have been instituted and are in place.
4. If there is a warning sign on the switch or engine starting controls, the operator shall not close the switch or start the engine until the warning sign has been removed by the appointed person.
5. Before closing the switch or starting the engine, the operator shall see that all controls are in the "OFF"

QUALIFICATIONS FOR AND CONDUCT OF OPERATORS AND OPERATING PRACTICES

- or neutral position and all personnel are in the clear.
6. If power fails during operation, the operator shall:
 - A. Move power controls to the "OFF" or neutral position.
 - B. Land the suspended load and boom, if practical.
 7. The operator shall be familiar with the equipment and its proper care. If adjustments or repairs are necessary, the operator shall report the same promptly to the appointed person, and shall also notify the next operator.
 8. The operator at the start of each shift shall test all controls. If any controls do not operate properly, they shall be adjusted or repaired before operations are begun.
 9. Stabilizers shall be visible to the operator while extending or setting unless a signal person assists operator.

OPERATING PRACTICES/HANDLING THE LOAD

1. Size of load.
 - A. No crane shall be loaded beyond the rated load except for test purposes.
 - B. The load to be lifted is to be within the rated load of the crane and its existing configuration.
 - C. When loads that are not accurately known are to be lifted, the person responsible for the job shall ascertain that the weight of the load does not exceed the crane rated load at the radius at which the load is to be lifted.
2. Attaching the load.
 - A. The load shall be attached to the hook by means of slings or other devices of sufficient capacity.
 - B. Hoist rope shall not be wrapped around the load.
3. Moving the load.

The operator shall determine that:

 - A. The crane is level and, where necessary, the vehicle/carrier is blocked properly.
 - B. The load is well secured and balanced in the sling or lifting device before it is lifted more than a few inches.
- C. Means are provided to hold the vehicle stationary while operating the crane.
- D. Before starting to lift, the hook shall be positioned over the load in such a manner as to minimize swinging.
- E. During lifting care shall be taken that:
 1. There is no sudden acceleration or deceleration of the moving load.
 2. Load, boom or other parts of the crane do not contact any obstruction.
- F. Cranes shall not be used for dragging loads sideways.
- G. This standard recognizes that telescopic boom cranes are designed and intended for handling materials. They do not meet personnel lift or elevator requirements. Therefore, no lifting, lowering, swinging or traveling shall be done while a person is on the hook or load. Hook attached suspended work platforms (baskets) shall not be used with cranes covered by this standard. Crane manufacturer must approve work platforms attached to the boom.
- H. The operator should avoid carrying loads over people.
- I. When the crane is so equipped, the stabilizers shall be fully extended and set. Blocking under stabilizers shall meet the requirements as follows:
 1. Strong enough to prevent crushing.
 2. Of such thickness, width and length as to completely support the stabilizer pad.
- J. Firm footing under all tires, or individual stabilizer pads should be level. Where such a footing is not otherwise supplied, timbers, cribbing, or other structural members to distribute the load so as to not exceed allowable bearing capacity or the underlying material should provide it.
- K. In transit, the boom shall be carried in stowed position.
- L. When rotating the crane, sudden starts and stops shall be avoided. Rotational speed shall be such that the load does not swing out beyond the radius at which it can be controlled.
- M. The crane shall not be transported with a load on the hook unless recommended by the manufacturer.

QUALIFICATIONS FOR AND CONDUCT OF OPERATORS AND OPERATING PRACTICES

N. No person should be permitted to stand or pass under a suspended load.

4. Stowing procedure.

Follow the manufacturer's procedure and sequence when stowing and un-stowing the crane.

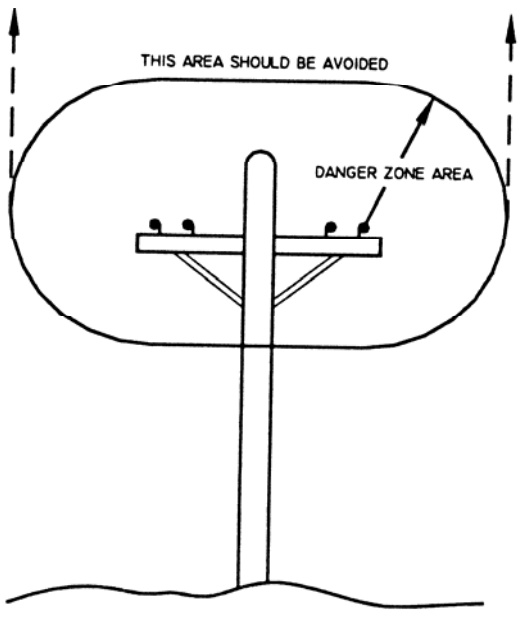
3. Caution shall be exercised when working near overhead lines, because they can move horizontally or vertically due to wind, moving the danger zone to new positions.

4. In transit with no load and boom lowered the clearance shall be specified in Table 1.

5. A qualified signalperson shall be assigned to observe the clearance and give warning before approaching the above limits.

MISCELLANEOUS

OPERATING NEAR ELECTRICAL POWER LINES



1. Cranes shall be operated so that no part of the crane or load enters into the danger zone shown above.

EXCEPTIONS

A. The danger zone may be entered after confirmation by an appointed person that the electrical distribution and transmission lines have been de-energized and visibly grounded at the point of work; or

B. The danger zone may be entered if insulating barriers (not a part of nor an attachment to the crane) have been erected to prevent physical contact with the lines.

2. For lines rated 50 kV or below, minimum clearance between the lines and any part of the crane or load (including handling appendages) shall be 10-ft. (3m). For higher voltages, see Table 1.

A. Any overhead wire shall be considered to be an energized line unless and until the person owning such line or the electrical utility authorities verify that it is not an energized line.

B. Exceptions to this procedure are allowed, if approved by the administrative or regulatory authority provided the alternate procedure insures equivalent protection and is set forth in writing.

C. Durable signs shall be installed at the operator's station and on the outside of the crane, warning that electrocution or serious bodily injury may occur unless a minimum clearance of 10 ft. (3.0m) between the crane or the load being handled and energized power lines. Greater clearances are required because of higher voltage as stated above. These signs shall be revised but not removed when local jurisdiction requires greater clearances.

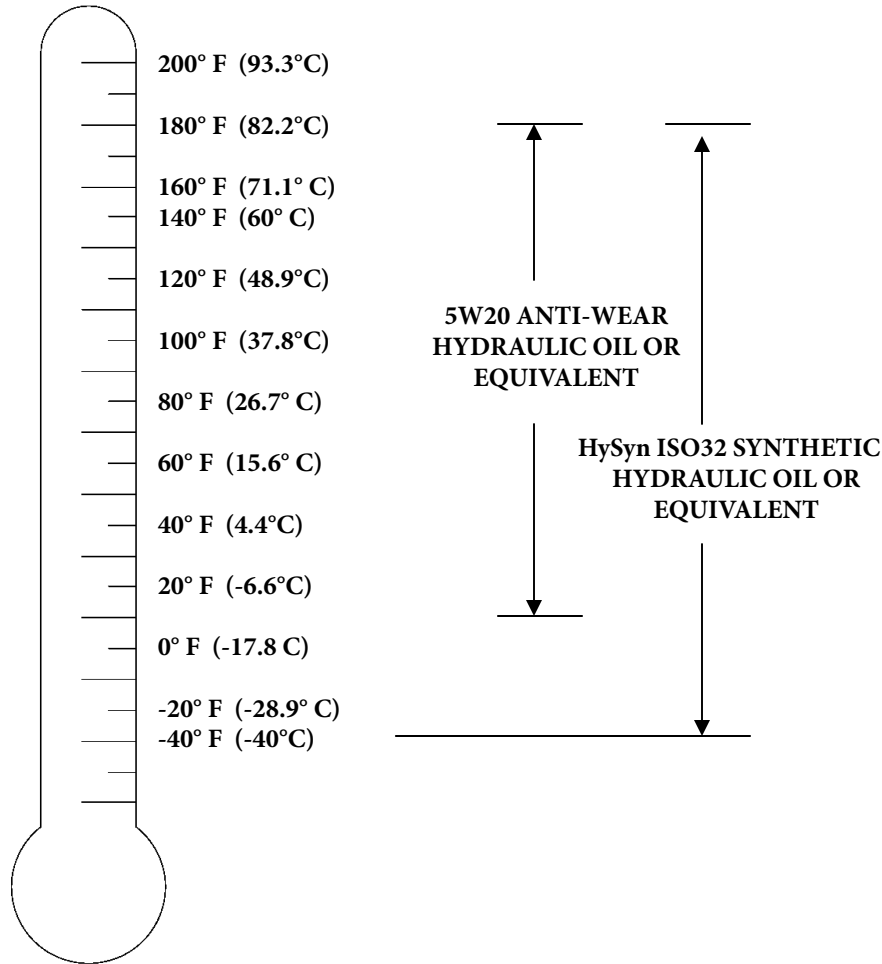
TABLE 1

normal voltage, kV (phase to phase)		minimum required clearance	
		ft	(m)
<u>when operating near high voltage power lines</u>			
over	to 50	10	(3.50)
over	50 to 200	15	(4.6)
over	200 to 350	20	(6.1)
over	350 to 500	25	(7.62)
over	500 to 750	35	(10.67)
over	750 to 1000	45	(13.72)
<u>while in transit with no load and boom lowered</u>			
over	to 0.75	4	(1.22)
over	0.75 to 50	6	(1.83)
over	50 to 345	10	(3.83)
over	345 to 750	16	(4.87)
over	750 to 1000	20	(6.1)

RANGE - SMALL EH CRANES

RECOMMENDED OPERATING TEMPERATURE

OIL TEMPERATURE



NOTES

- 1. In applications where low oil temperatures may exist (below -20°F), an external heating system may be required.**
- 2. A symptom of excessively low temperatures is hydraulic motor operation but no fluid flow from tank.**

CAUTION! HYDRAULIC RESERVOIR OIL TEMPERATURE MUST NOT EXCEED 180°F OR DAMAGE TO CRANE MAY OCCUR. THIS MAY AFFECT CRANE WARRANTY

--- IMPORTANT --- OPERATION OF UNIT

1. Make sure this manual has been thoroughly read by all crane operating personnel and supervisors.
2. A routine inspection of the crane should be mandatory before each operating day. Any defects should be corrected immediately.
3. At a job site the vehicle should be positioned so that the crane can adequately reach the load within the rated capacity (centerline of rotation to hoist hook).
4. Keep the vehicle as level as possible during operation.
5. For electric cranes, engage emergency brake and leave ignition on with transmission in neutral (or in park for automatic transmissions). Activate any crane power switches. For Auto Crane units requiring battery and hydraulic operation, engage emergency brake, place gear selector in neutral, press clutch, activate PTO, release clutch and, after hydraulic fluid is warm, set throttle control to proper engine speed.
6. Always use outriggers from the truck to the ground. Be sure these are firm and adequately positioned. When rotating, keep load as low to the ground as possible.
7. Remove the transmitter from cab or storage area. Power transmitter on. Detach hook from dead man. Crane is now ready for operation.
8. Always boom up before rotating so the boom will clear the required boom support.
9. When extending the boom, always maintain clearance between the boom crown and the traveling block or hoist hook.
10. Always observe safe and practical operation to avoid possible accidents. Refer to Safety Tips and Precautions.
11. After completing lifting operations, return the boom to stowed position on the boom support. Avoid unneeded pressure on the boom support.
12. Store transmitter in proper location (in cab or storage area).
13. Return outriggers to stowed position. Make sure they are pinned in place or jacklegs are returned to compartment.
14. Check work area for any tools or equipment not stored.
15. Release throttle control, depress clutch and disengage PTO. Deactivate any crane power switches.
16. Report any unusual occurrence during crane operation that may indicate required maintenance or repair.
17. NEVER use two cranes to support a load too large for either crane.

OPERATION OF OUTRIGGERS

HYDRAULIC OUTRIGGERS

1. Shift crane/outrigger control valve to "outrigger" position.
2. Operate the outrigger control valves to position the outriggers.
3. After outriggers are positioned, return crane/outrigger selector to "crane" position.
4. Crane is now ready to operate.

MANUAL OUTRIGGERS

1. Pull lock pins to release jackleg or drop down outrigger and move to outermost lock position.
2. Make sure lock pins are reinstalled properly.
3. Lower outrigger pad to firm ground and adjust foot to take out slack.
4. Crane is now ready to operate.

INSPECTION REQUIREMENTS

REFERENCE ASME B30.5a AND OSHA 1910.180 FOR COMPLETE INSPECTION REQUIREMENTS

INSPECTION CLASSIFICATION

1. Initial inspection.

Prior to initial use, all new, altered, modified or extensively repaired cranes shall be inspected by a designated person to insure compliance with provisions of this standard.

2. Regular inspection.

Inspection procedure for cranes in regular service is divided into two general classifications based upon the intervals at which inspection should be performed. The intervals in turn are dependent upon the nature of the components of the crane and the degree of their exposure to wear, deterioration, or malfunction. The two general classifications are herein designated as "frequent" and "periodic" with respective intervals between inspections as defined below.

- A. Frequent inspection - daily or before each use
- B. Periodic inspection - one to twelve-month intervals or as specifically recommended by the manufacturer or qualified person.

DESIGNATED PERSONNEL SHALL
PERFORM INSPECTIONS ONLY.

FREQUENT INSPECTION

Inspections should also occur during operation for any deficiencies that might appear between regular inspections. Any deficiencies, such as those listed below, shall be carefully examined and a determination made as to whether they constitute a hazard:

1. Inspect control mechanisms for maladjustment that interferes with proper operation.
2. Inspect control mechanisms for excessive wear of components and contamination by lubricants or other foreign matter.

3. Inspect safety devices for malfunction.
4. Visually inspect all hydraulic hoses, particularly those that flex in normal operation of crane functions.
5. Inspect hooks and latches for deformation, chemical damage, cracks, and wear. Refer to ANSI/ASME B30.10.
6. Inspect for proper rope reeving.
7. Inspect electrical wiring and components for malfunctioning, signs of excessive deterioration, dirt and moisture accumulation.
8. Inspect hydraulic system for proper oil level and leaks.
9. Inspect tires for recommended inflation pressure, cuts and loose wheel nuts.
10. Inspect connecting pins and locking device for wear damage and loose retaining bolts.
11. Inspect rope for gross damage, such as listed below, which may be an immediate hazard.
 - A. Distortion such as kinking, crushing, unstranding, birdcaging, main strand displacement, or core protrusion. Loss of rope diameter in a short length or unevenness of outer strands should be replaced.
 - B. General corrosion.
 - C. Broken or cut strands.
 - D. Use care when inspecting sections of rapid deterioration around flange points, crossover points, and repetitive pickup points on drums.
 - E. Inspect number, distribution, and type of visible broken wires. Reference Rope Maintenance section in the owner's manual.

Continued use of rope depends upon good judgment by a designated person in evaluating remaining strength in a used rope after allowance for deterioration disclosed by inspection. Continued rope operation depends upon this remaining strength.

INSPECTION REQUIREMENTS

PERIODIC INSPECTION

Any deficiencies, such as those listed below, shall be carefully examined and determination made as to whether they constitute a hazard:

1. Inspect for deformed, cracked or corroded members in the crane structure and entire boom.
2. Inspect for loose bolts, particularly mounting bolts.
3. Inspect for cracked or worn sheaves and drums.
4. Inspect for worn, cracked, or distorted parts such as pins, bearings, shafts, gears, rollers and devices.
5. Inspect for excessive wear on brake and clutch system parts and lining.
6. Inspect crane hooks for cracks.
7. Inspect travel steering, braking, and locking devices for malfunction.
8. Inspect for excessively worn or damaged tires.
9. Inspect hydraulic hose, fittings, and tubing for the following problems:
 - A. Evidence of leakage at the surface of the flexible hose or its junction with metal and coupling.
 - B. Blistering, or abnormal deformation to the outer covering of the hydraulic or pneumatic hose.
 - C. Leakage at threaded or clamped joints that cannot be eliminated by normal tightening or recommended procedures.
 - D. Evidence of excessive abrasion or scrubbing on the outer surface of a hose, rigid tube, or fitting. Means shall be taken to eliminate the interference of elements in contact or otherwise protect the components.
10. Inspect hydraulic pumps and motors for the following problems:
 - A. Loose bolts and fasteners.
 - B. Leaks at joints between sections.
 - C. Shaft seal leaks.
 - D. Unusual noises or vibrations.
 - E. Loss of operating speed.
 - F. Excessive heating of the fluid.
 - G. Loss of pressure.
11. Inspect hydraulic valves for the following problems:
 - A. Cracks in valve housing.
 - B. Improper return of spool to neutral position.
 - C. Leaks at spools or joints.
 - D. Sticking spools.
 - E. Failure of relief valves to attain or maintain correct pressure setting.
 - F. Relief valve pressure shall be checked as specified by the manufacturers.
12. Inspect hydraulic cylinders for the following problems:
 - A. Drifting caused by fluid leaking across piston.
 - B. Rod seals leaking.
 - C. Leaks at welding joints.
 - D. Scored, nicked, or dented cylinder rods.
 - E. Damaged case (barrel).
 - F. Loose or deformed rod eyes or connecting joints.
13. Inspect hydraulic filters for evidence of rubber particles on the filter elements indicating possible hose, O ring, or other rubber component deterioration. Metal chips or pieces on the filter may denote failure in pumps, motors, or cylinders. Further inspection will be necessary to determine the origin of the problem before corrective action can be taken.
14. Inspect labels to confirm correct location and legibility. Reference decal layout in this manual for proper location of decals.
15. Rope Inspections need not be at equal calendar intervals and should be more frequent as the rope approaches the end of useful life.

A qualified person shall inspect the wire rope based on such factors as:

 - A. Expected rope life as determined by experience on the particular installation or similar installations.
 - B. Severity of environment.
 - C. Percentage of capacity lifts.
 - D. Frequency rates of operation.
 - E. Exposure to shock loads.

This inspection shall cover the entire length of the rope. Only the surface wires need to be inspected and no attempt should be made to open the rope. Any deterioration resulting in appreciable loss of original strength shall be noted and determination made as to whether use of the rope would constitute a hazard. A few notable deterioration points are listed below:

INSPECTION REQUIREMENTS

- A. Reduction of rope diameter below nominal diameter due to loss of core support.
- B. Internal or external corrosion.
- C. Wear of outside wires.
- D. Severely corroded, cracked, bent, worn, or improperly applied connections.

CRANES NOT IN REGULAR USE

A crane, which has been idle for a period of over one month or more, shall be given an inspection conforming to the “initial” and “regular” inspection requirements of this section.

INSPECTION RECORDS

Dated records of periodic inspection should be made on critical items such as brakes, crane hooks, rope, cylinders, and relief pressure valves.

TESTING REQUIREMENTS

REFERENCE ASME B30.5a AND OSHA 1910.180 FOR COMPLETE TESTING REQUIREMENTS

TESTING SHALL BE PERFORMED BY DESIGNATED PERSONNEL ONLY.

Prior to initial use, all new, altered, modified, or extensively repaired cranes shall be tested for compliance with the operational requirements of this crane.

Test requirements:

- 1. Test all functions to verify speed and operation.**
- 2. Check that all safety devices are working properly.**
- 3. Confirm operating controls comply with appropriate function labels.**
- 4. Test loads shall not exceed 110% of the manufacturer's load rating.**
- 5. Written reports shall be maintained showing test procedures and confirming the adequacy of repairs.**

GENERAL REPAIRS AND MAINTENANCE

REFERENCE ASME B30.5a AND OSHA 1910.180 FOR COMPLETE MAINTENANCE AND REPAIR REQUIREMENTS

A preventative maintenance program should be established based on this section and all replacement parts should be obtained from AutoCrane Company. For replacement parts contact your local authorized distributor.

MAINTENANCE PRECAUTIONS

1. Place crane where it will cause the least interference with other equipment or operations.
2. Verify all controls are in the "off" position and all operating features secured from inadvertent motion by brakes, pawls, or other means.
3. The means for starting the crane shall be rendered inoperative.
4. The boom should be secured in place before maintenance.
5. Relieve hydraulic oil pressure from all hydraulic circuits before loosening or removing hydraulic components.
6. Warning or "OUT OF ORDER" signs shall be placed on all crane controls.
7. After adjustments and repairs have been made, the crane shall not be returned to service until all guards have been reinstalled, trapped air removed from hydraulic system (if required), safety devices reactivated, and maintenance equipment removed.

ADJUSTMENTS AND REPAIRS

1. Any hazardous conditions disclosed by the inspection requirements shall be corrected before operation of crane is resumed. Only designated personnel shall do adjustments and repairs.
2. Adjustments shall be maintained to assure correct functioning of components, the following are examples:
 - A. Functional operating mechanism.
 - B. Safety devices.
 - C. Control systems.
3. Repairs or replacements shall be provided as needed for operation, the following are examples:
 - A. Critical parts of functional operating mechanisms which are cracked, broken, corroded, bent, or excessively worn.

- B. Critical parts of the crane structure which are cracked, bent, broken, or excessively corroded.
 - C. Crane hooks showing cracks, damage, or corrosion shall be taken out of service. Repairs by welding are not recommended.
4. If bleeding the hydraulic system is required, run each crane function until smooth operation of that particular function is noticeable.

LUBRICATION

All moving parts of the crane, for which lubrication is specified, should be regularly lubricated per the manufacturer's recommendations and procedures. Reference Lubrication and Maintenance Schedule in this manual.

ROPE REPLACEMENT

No precise rules can be given for determination of the exact time for replacement of rope, since many variable factors are involved.

1. Conditions such as the following shall be reason for questioning continued use of the rope or increasing the frequency of inspection:
 - A. In running ropes, six randomly distributed broken wires in one lay or three broken wires in one strand in one lay.
 - B. One outer wire broken at the contact point with the core of the rope structure and protrudes or loops out of the rope structure. Additional inspection of this section is required.
 - C. Wear of one third of the original diameter of the outside individual wire.
 - D. Kinking, crushing, bird caging, or any other damage resulting in distortion of the rope structure.
 - E. Evidence of any heat damage from any cause. F. Reduction from nominal diameter of more than 1/64 in. (0.4mm) for diameters up to and including 5/16 in. (8 mm), 1/32 in. (0.8 mm) for diameter 3/8 in. (9.5 mm) to and including 1/2 in. (13 mm), 3/64 in. (1.2 mm) for diameter 9/16 in. (14.5 mm) to and including 3/4 in. (19 mm), 1/16 in. (1.6 mm) for diameter 7/8 in. (22 mm) to and including 1 1/8 in. (29 mm), 3/32 in.

GENERAL

REPAIRS AND MAINTENANCE

(2.4 mm) for diameters 1 1/4 in. (32 mm) to and including 1 1/2 in. (38 mm).

- G. In standing ropes, more than two broken wires in one lay in sections beyond end connections or more than one broken wire at an end connection.
2. Replacement rope shall have a strength rating at least as great as the original rope furnished or recommended by AutoCrane. A rope manufacturer, AutoCrane, or a qualified person shall specify any deviation from the original size, grade, or construction.

ROPE MAINTENANCE

1. Rope should be stored to prevent damage or deterioration.
2. Unreeling or uncoiling of rope shall be done as recommended by the rope manufacturer and with care to avoid kinking or inducing twist.
3. Before cutting a rope, seizing shall be placed on each side of the place where the rope is to be cut to prevent unlaying of the strands. On pre-formed rope, one seizing on each side of the cut is required. On non-preformed ropes of 7/8 in. (22 mm) diameter or smaller, two seizings on each side of the cut are required, and for non-preformed rope 1 in. (25 mm) diameter or larger, three seizings on each side of the cut are required.
4. During installation care should be exercised to avoid dragging of the rope in the dirt or around objects that will scrape, nick crush or induce sharp bends in it.
5. Rope should be maintained in a well-lubricated condition. It is important that lubricant applied as a part of a maintenance program shall be compatible with the original lubricant and to this end the rope manufacturer should be consulted. Lubricant applied shall be the type that does not hinder visual inspection. Those sections of rope that are located over sheaves or otherwise hidden during inspection and maintenance procedures require special attention when lubricating rope. The object of rope lubrication is to reduce internal friction and to prevent corrosion.
6. When an operating rope shows greater wear or well-defined localized areas than on the remainder of the rope, rope life can be extended in some cases by shifting the wear to different areas of the rope.

MAINTENANCE OF BATTERIES

Maintenance of Auto Crane unit batteries differs very little from the generally prescribed maintenance of any lead acid battery. All batteries must be kept properly charged, properly filled with water, and relatively clean.

Keep Properly Charged

Many things affect the proper charge to a battery, such as:

1. Regulator settings.
2. Proper tightness of belts on the alternator or generator.
3. Good, clean connections of all cables and wires at the following places:
 - a. Battery.
 - b. Regulator.
 - c. Starting motor.
 - d. Alternator or generator.
 - e. Ground connections (most important).

It is of extreme importance to keep the battery as fully charged as possible without overcharging, especially when vehicles are left outside for extended periods in extremely cold climates. A battery can freeze. Freezing points for various specific gravities of acid are as follows:

Specific Gravity (Corrected to 80°F)	Freezing Temp. Degrees F.
1.280	-90°F
1.250	-62°F
1.200	-16°F
1.150	5°F
1.100	19°F

As shown, a half-charged battery (about 1.100 specific gravity) cannot stand for any length of time at 20°F or it will freeze.

The main reason for keeping the battery as fully charged as possible without over-charging is to insure that power is available even though the vehicle has been standing for some time.

Keep Properly Filled with Water

The battery should *always* be properly filled with water. If the electrolyte level is allowed to fall below the top of the plates, the results become threefold:

1. The exposed portion of the plate will become sulfated.
2. The portion of the plate exposed is not usable.
3. That portion of the acid remaining becomes more concentrated and may cause more rapid

deterioration of the remaining parts of the battery.

Keep A Relatively Clean Battery

The battery should be kept clean. Batteries filled with acid and which are not in use self-discharge to a limited degree because of the nature of the materials within the battery. If dirt is allowed to collect on the top of the battery (and this dirt absorbs moisture) and electrical path can be set up between the various terminals of the battery and the ground. Once such a path has been established, the selfdischarge of the battery is accelerated. This also accelerates corrosion of the battery cables at the terminals.

Periodic Maintenance is Needed

A definite program of periodic maintenance of all batteries should be conducted on a regular basis.

Periodic maintenance includes:

1. Checking belts for tightness on the charging equipment.
2. Checking battery electrolyte levels.
3. Checking cables for good connections.
4. Cleaning where corrosion is apparent.

When corrosion is cleaned off, the cable terminals and battery terminals should be coated with a light coating of petroleum jelly before they are replaced. When terminals are cleaned, the top of the battery should be cleaned with a mild solution of soda water.

Low Maintenance Batteries

(Maintenance Free)

Low maintenance batteries should not be used on AutoCrane Cranes or trucks equipped with AutoCrane Cranes. The batteries are not designed for "deep" discharge.

Testing Your Battery

If the condition of the battery is in question, it should be removed from the vehicle, taken to the shop, and allowed to reach room temperature. It should then be recharged until specific gravity readings taken at one-half hour intervals. If the specific gravity readings are fairly uniform, the battery should be checked with a high rate tester. Use the tester in accordance with the manufacturer's instructions. The high rate tester is the best method to test a questionable battery.

MAINTENANCE OF BATTERIES

If, after charging, it is noted that the specific gravity reading of one cell is 30 points less than any of the other cells, it may be assumed that the cell is bad and that the battery should be replaced. If all cells are uniform but not up to full charge, a low rate of charge should be attempted for an extended time. This usually will recover a badly sulfated battery.

Replacing a Battery

If it is necessary to replace a battery, and a dry charge battery is used, the following procedure applies:

1. Fill the battery with electrolyte of the proper specific gravity.

2. Place the battery on charge according to the manufacturer's instructions.

It is essential that the second step above be followed to ensure that the battery going on the vehicle is fully charged.

It is also very important that the battery hold-downs be checked periodically to insure that the batteries are properly positioned to avoid vibration problems, breakage of cables or terminals. Care must be taken to avoid cracking or breaking containers or covers by tightening hold-down fixtures excessively. They also must not be so loose that breakage results from a hold-down that is too loose.

3203PR/PRX

LUBRICATION & MAINTENANCE SCHEDULE

SERVICE PERFORMED	DAY	WKLY	3 MOS	6 MOS	YEAR	NOTES
LOAD HOOK	X					INSPECT HOOK & LATCH FOR DEFORMATION, CRACKS, & CORROSION
CABLE DRUM	X					MAKE SURE CABLE IS WOUND EVENLY ON DRUM
HOIST / BOOM CABLE	X					CHECK FOR FLATTENING, KINKS, & BROKEN STRANDS, SEE MANUAL
HYD. HOSES	X					VISUAL INSPECTION
HYD. FLUID	X					CHECK FLUID LEVEL
MOTOR CONNECTIONS		X				CHECK TERMINALS FOR TIGHT CONNECTIONS
POWER CABLE			X			CHECK INSULATION FOR DAMAGE OR DETERIORATION
PIN RETAINING BOLTS	X					CHECK TORQUE TO 23 FT-LBS (GRADE 5), 35 FT-LBS (GRADE 8) AS REQUIRED
MOUNTING BOLTS		X				CHECK TORQUE TO 335 FT-LBS FOR 3/4-16
ROTATION RING GEAR		X				LUBE WITH MOBILETAC LL, OR LUBRIPLATE P/N 15263, OR EQUAL
SHEAVE BEARINGS		X				SEALED BEARING, REPLACE IF ROUGH OR LOOSE
ALL OTHER BOLTS		X				CHECK TIGHTEN AS REQUIRED
LIFT CYLINDER BEARINGS			X			GREASE WITH MOBILEPLEX EP-2 OR EQUIVALENT @ ZERKS
ROTATION BEARING			X			GREASE WITH MOBILEPLEX EP-2 OR EQUIVALENT @ ZERKS
ROTATION BEARING BOLTS			X			CHECK TORQUE TO 170 FT-LBS (HEX HEAD)
ROTATION WORM BEARING				X		GREASE WITH MOBILEPLEX EP-2 OR EQUIVALENT @ ZERKS
HYDRAULIC FLUID				X		DRAIN, FLUSH, AND REFILL WITH MOBILE DTE 13 HYD. OIL
BOOM SLIDE PADS						PADS GREASED WHEN REPLACED
FOR ADDITIONAL INFORMATION SEE: <ol style="list-style-type: none"> 1) OWNER'S MANUAL 2) OSHA SECTION 1910.180 3) ANSI B30.5-1989 						

CAUTION: Routine maintenance insures trouble-free operation and protects your investment. All warranties are void if maintenance is neglected.

3203PR/PRX

LUBRICATION & MAINTENANCE SCHEDULE

NOTES:

1. Use only authorized parts. Any damage or malfunction caused by the use of unauthorized parts is not covered by Warranty or Product Liability.
2. Once a bolt has been torqued to its rated capacity and then removed; the bolt should be replaced with a new one.
3. Auto Crane Company recommends that this crane be serviced per "Crane Inspection Log" P/N 999978. These logs should be filled in at the intervals noted and kept as a permanent record. Additional copies are available from your local distributor.

3203EH SINGLE LINE PROCEDURE

CONVERTING FOR SINGLE LINE TO DOUBLE LINE ON 3203EH CRANES

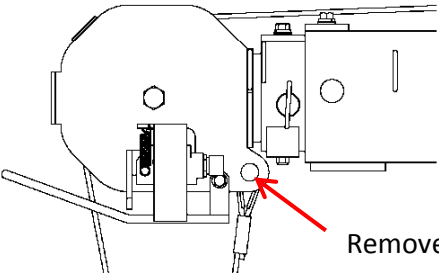
This procedure gives step by step directions for taking a double line and converting to a single line. Keep in mind when using a single line, the max capacity drops from 3200lbs to 1600lbs.

- 1. Remove hook from traveling block by removing pin

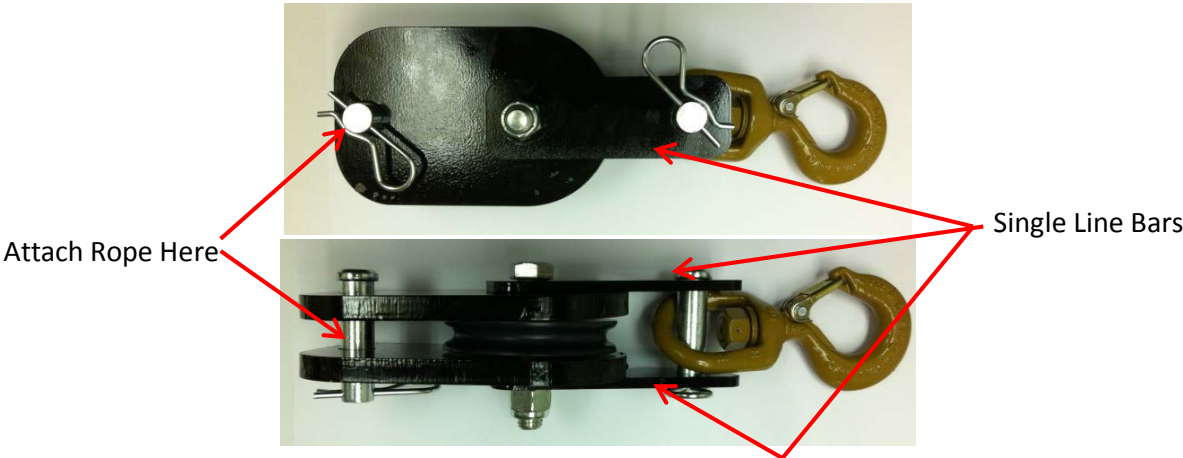


Figure 1

- 2. Remove traveling block from rope
- 3. Disconnect the rope from the crown by removing pin.



- 4. Pivot single line bars 180 degrees then attach hook to the bars using the pin removed in step 1
- 5. Attach the rope to the traveling block side plates using the pin removed in step 3. Reference pictures below for proper configuration.



3203PR/PRX/PRFX BRAKE ADJUSTMENT

ADJUSTING OIL COOLED WORM BRAKE

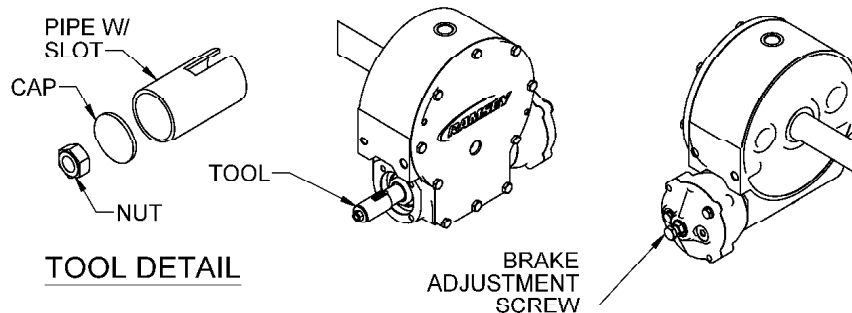
The oil-cooled, fully adjustable, automatic safety brake operates in the worm housing lubricant, all part being submerged in oil. When the brake wears to the point that the load begins to drift, the brake can be adjusted as follows:

1. Loosen the lock nut on the adjusting screw.
2. Tighten the brake by turning the adjusting screw clockwise.

CAUTION: Only $\frac{1}{4}$ turn is usually required to adjust the brake. Over-tightening can cause overheating, and damage to the brake parts. Tighten the lock nut after adjustment is completed.

If the brake does not respond to adjustment then a new leaf spring and brake disc is needed.

A torque wrench can be equipped with a special adapter to fit the input shaft (worm) of the winch. The adapter can be made by welding a nut to the end of a piece of tubing as shown in the following figure.



After welding the cap and nut to the tubing, slot the tubing as shown. This will allow the special adapter to slide over the keyway and then act as a large socket. A torque wrench can then be used to apply the proper torque. Turn the torque wrench so that the drum turns in the spool out direction or lowering direction. The torque ratings should be between 12-16 ft-lbs.

If the torque wrench does not show the proper value as it turns, then the worm brake adjusting bolt should be turned clockwise $\frac{1}{4}$ turn. Each time the adjusting bolt is turned, check the torque reading. Continue this procedure until the proper torque reading is achieved. Then tighten the lock nut.

ROTATION BEARING REPLACEMENT GUIDELINES-2003-4004

All bearings can wear over time. This includes the main rotation bearing on the crane. No precise rules can be given for replacement of the rotation bearing, since many factors are involved. However, there are common symptoms seen during crane operation that may be caused by rotation bearing wear. These symptoms include:

1. Excessive Noise
2. Rough rotation
3. Increased drive power required to rotate.
4. Metal particles in grease

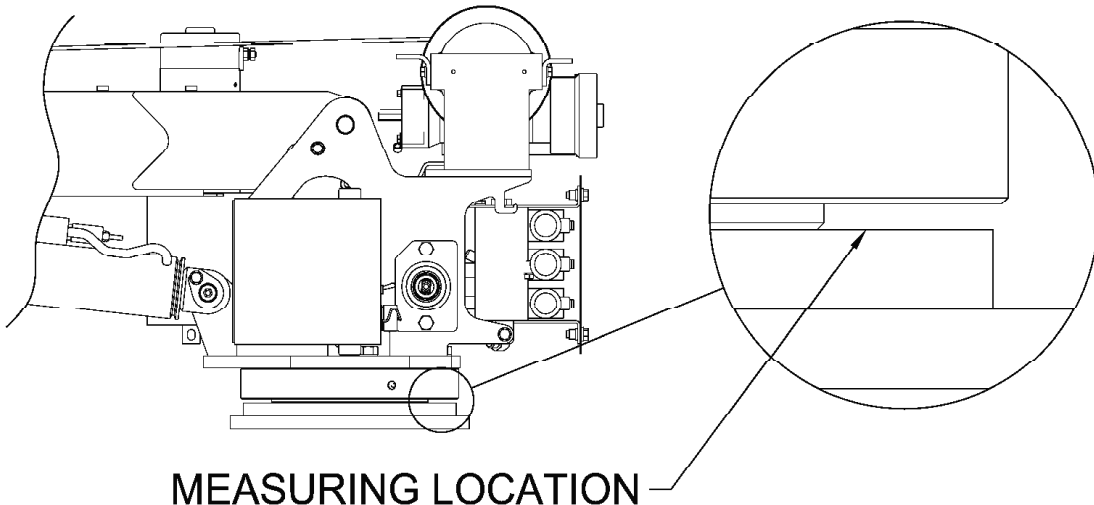
REASONS FOR ROTATION BEARING REPLACEMENT

1. Any noticeable cracking in the bearing housing
2. Excessive axial play (reference axial play check instructions below)

WARNING! NEVER TRY TO REPAIR A ROTATION BEARING. FOR A REPLACEMENT BEARING CONTACT YOUR LOCAL AUTHORIZED DISTRIBUTOR.

AXIAL PLAY ALLOWANCE CHECK PROCEDURE

1. Boom up to the max boom angle and measure the clearance between base plate and the rotation bearing with a dial or filler gauge. Reference figure 1 for location.
2. Boom down to the horizontal position and measure the clearance between the base plate and the rotation bearing with a dial indicator or feeler gauge. Reference figure 1 for location.
3. If the difference between the two measurements exceeds 1.5mm, replace bearing.
4. Rotate crane 45 degrees then repeat steps above until you reach 360 degrees of rotation.

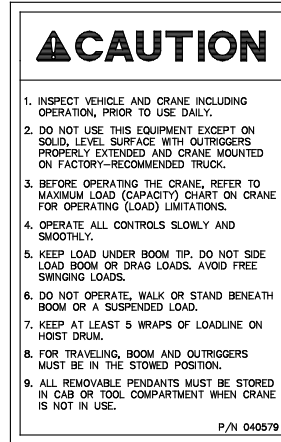


Rotation bearing replacement kit part number is 320878010

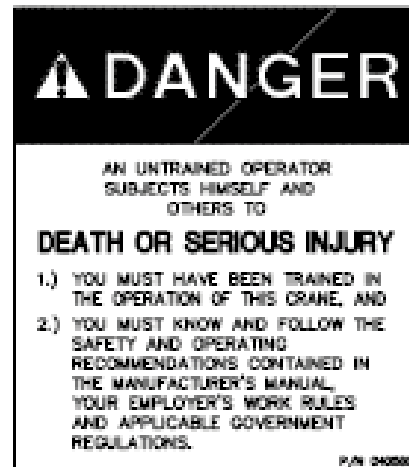
WARNING! WHEN REPLACING ROTATION BEARING, USE NEW HARDWARE WHICH IS INCLUDED IN THE KIT ABOVE.

3203PR/PRX SAFETY DECAL SECTION

PART NO.: 040579000
DECAL: OPERATING INSTRUCTIONS
FUNCTION: To inform the operator of the proper procedure to follow for safe operation of the crane.
USED ON: All Cranes
QUANTITY: 1
PLACEMENT: Right side plate



PART NO.: 040580000
DECAL: OPERATING TRAINING
FUNCTION: To inform the operator of the need to receive proper training before using the crane.
USED ON: All Cranes
QUANTITY: 1
PLACEMENT: Right side plate

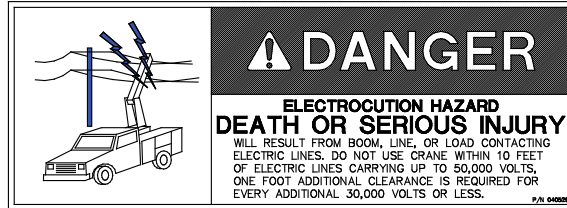


PART NO.: 040632000
DECAL: TAMPERING WITH OVERLOAD DEVICE
FUNCTION: To inform the operator that tampering with the overload device may cause a unit failure or possible personal injury.
USED ON: All Cranes equipped with a load sensor
QUANTITY: 1
PLACEMENT: Right side of valve sensor.

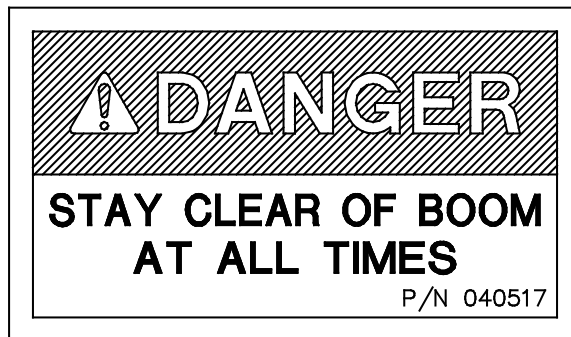


3203PR/PRX SAFETY DECAL SECTION

PART NO.: 040529000
DECAL: ELECTROCUTION HAZARD
FUNCTION: To inform the operator of the hazard involved with contacting electrical power lines with crane boom.
USED ON: All Cranes
QUANTITY: 2
PLACEMENT: Both sides of end of lower boom



PART NO.: 040517000
DECAL: STAY CLEAR OF BOOM
FUNCTION: To inform the operator of the hazard of proximity or contact with the crane boom during operation.
USED ON: All Cranes
QUANTITY: 2
PLACEMENT: Both sides of crown



PART NO.: 040518000
DECAL: STAY CLEAR OF LOAD
FUNCTION: To inform the operator of the hazard of proximity or contact with the crane load during operation.
USED ON: All Cranes
QUANTITY: 2
PLACEMENT: Both sides of traveling block



3203PR/PRX SAFETY DECAL SECTION

PART NO.: 040587000

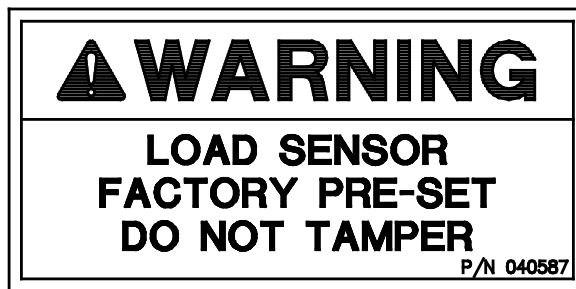
USED ON: All cranes equipped with a load sensor.

DECAL: LOAD SENSOR, DON'T TAMPER

QUANTITY: 2

FUNCTION: To inform the operator that the load sensor is pre-set and that tampering with the sensor may cause potentially hazardous situation.

PLACEMENT: Both sides of the lift cylinder near the load sensor



PART NO.: 040519000

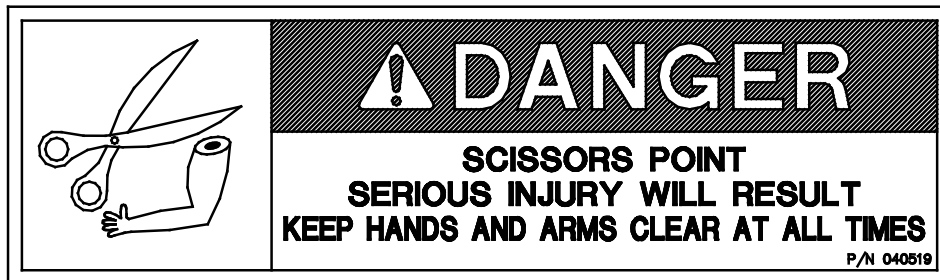
USED ON: All cranes.

DECAL: SCISSORS POINT

QUANTITY: 2

FUNCTION: To inform the operator of possible danger at scissors point on crane.

PLACEMENT: Both sides of the lift cylinder



3203PR/PRX

SAFETY DECAL SECTION

PART NO.: 460169000

USED ON: All Cranes equipped with FM controls.

DECAL: REMOTE CONTROL

QUANTITY: 1

FUNCTION: To inform the operator of failure to follow the safety precautions may result in equipment failure or serious personal injury.

PLACEMENT: FRONT OF POWER UNIT



WARNING

REMOTE CONTROL SAFETY PRECAUTIONS

READ THE OPERATOR'S MANUAL before using the Remote Control System. Failure to follow the safety precautions may result in equipment failure or serious personal injury.

MAKE SURE MACHINERY AND SURROUNDING AREA IS CLEAR BEFORE OPERATING REMOTE CONTROL SYSTEM. Do not activate the Remote Control System unless it is safe to do so.

TURN OFF THE RECEIVER POWER BEFORE WORKING ON THE MACHINE. Always disconnect the Remote Control System before doing any maintenance to prevent accidental operation of the machine.

DO NOT MODIFY EQUIPMENT WITHOUT WRITTEN APPROVAL FROM THE MANUFACTURER.

CARE

KEEP DRY. Do not clean the Transmitter / Receiver under high pressure. If water or other liquids get inside the Transmitter battery or Receiver compartment, immediately dry the unit. Remove the case and let the unit air dry.

Clean the unit after operation using a damp cloth to remove any mud, dirt, concrete, etc. from the unit and prevent clogging of buttons, switches, etc.

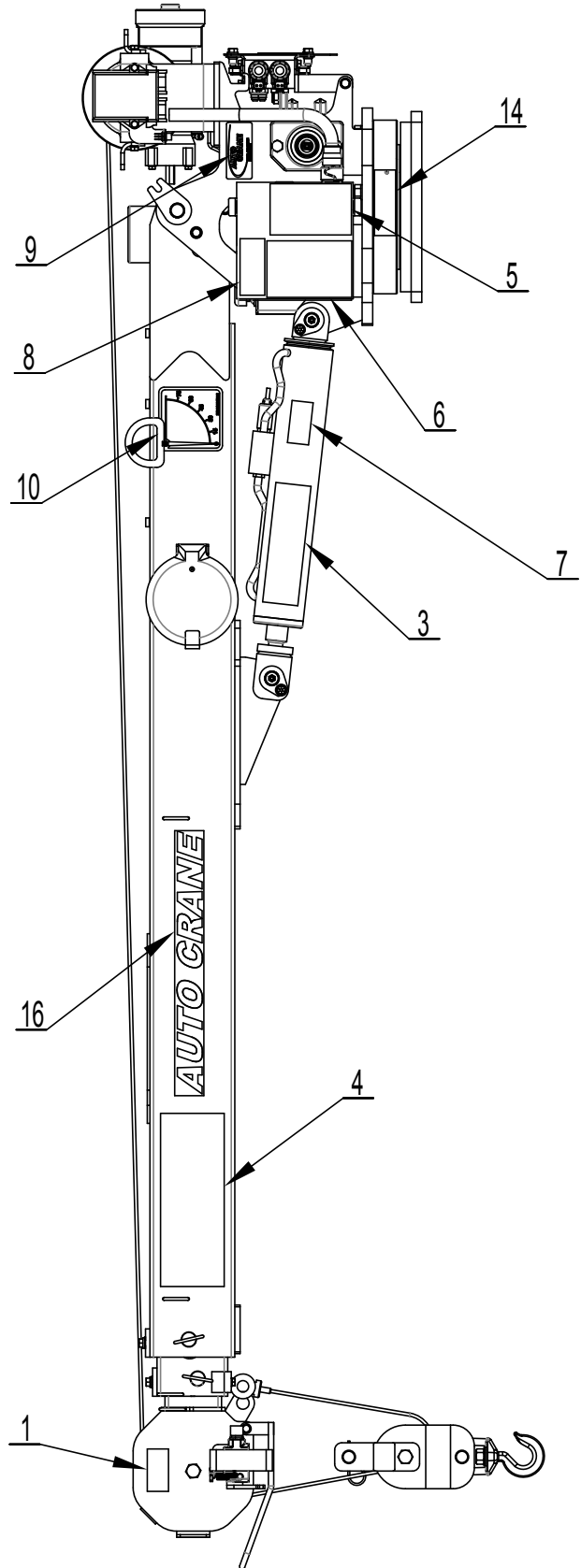
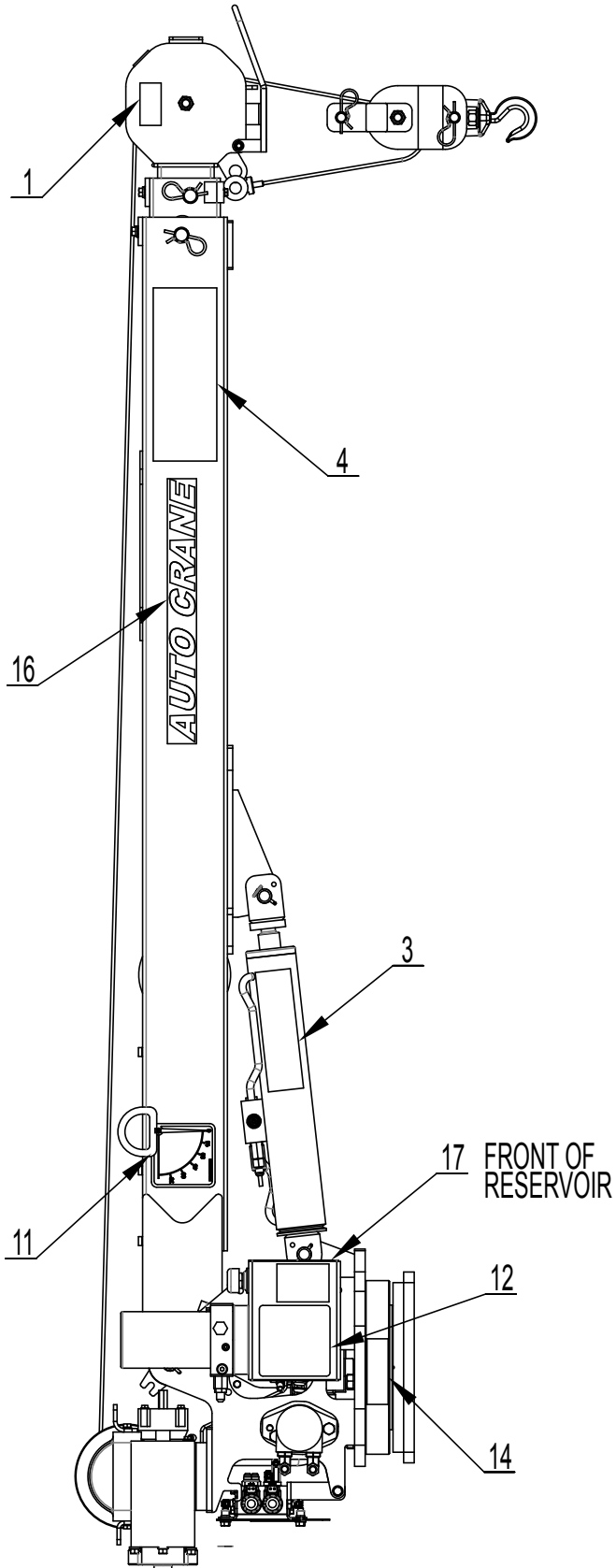
MAINTENANCE / WELDING

DISCONNECT THE RECEIVER BEFORE WELDING ON THIS MACHINE. Failure to disconnect will result in the destruction of the Receiver.

460169000 A

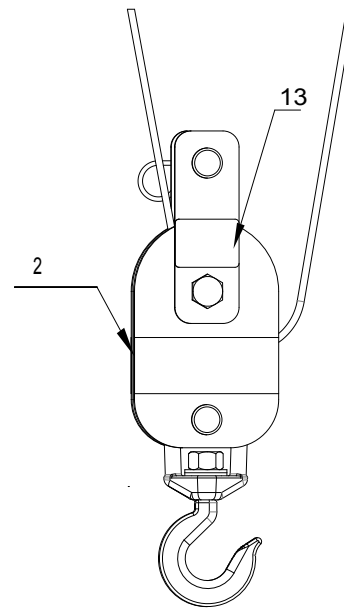
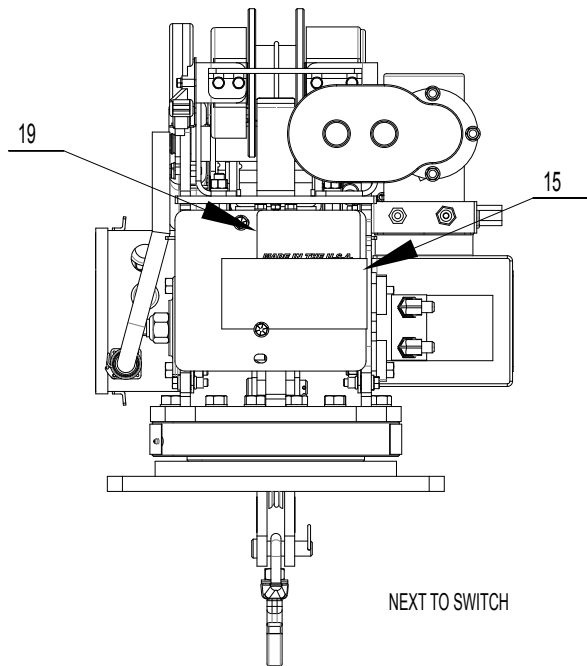
3203PR/PRX DECAL LAYOUT

P/N: 320988004



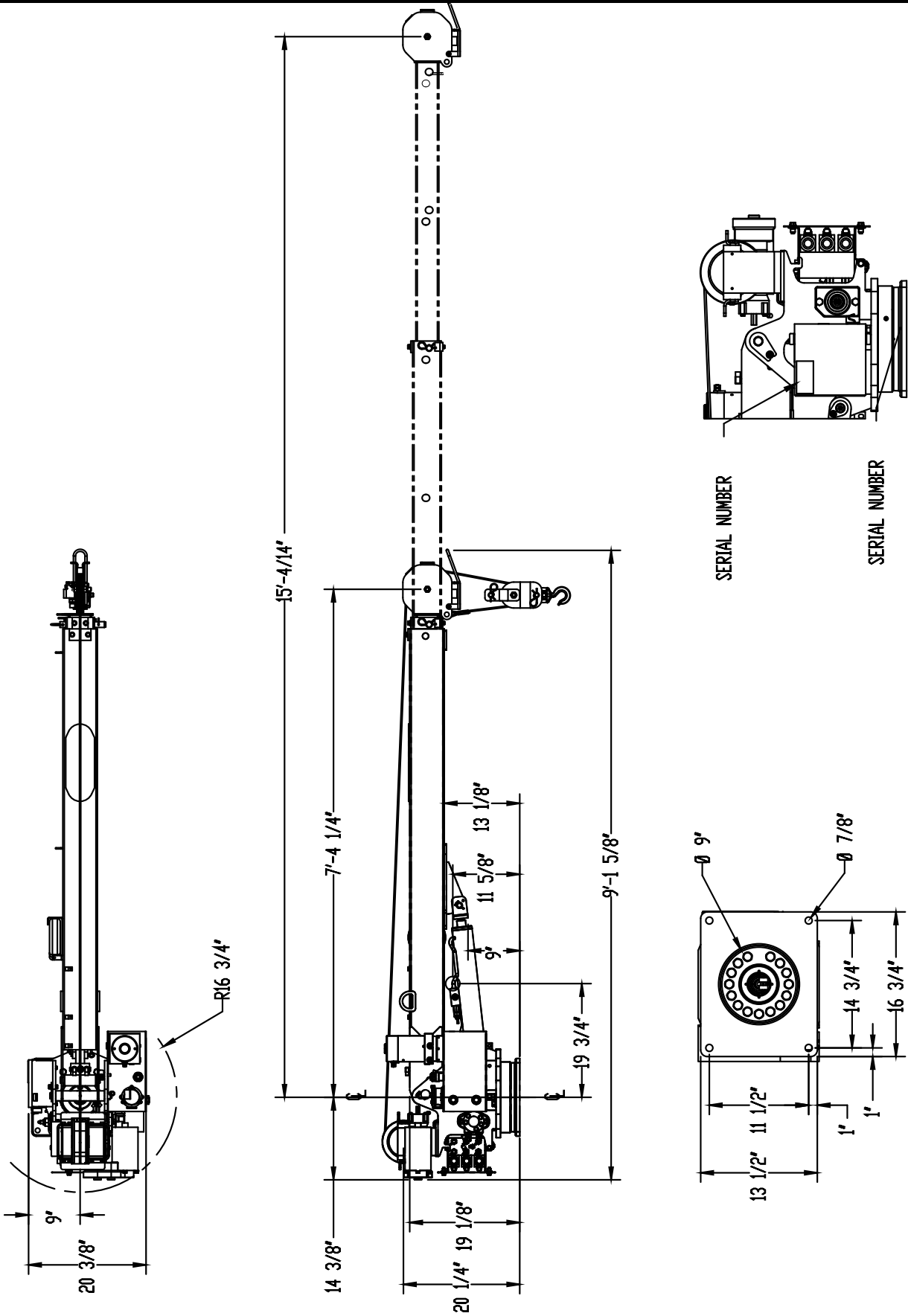
3203PR/PRX DECAL LAYOUT

P/N: 320988004



ITEM NO.	QTY	PART NUMBER	DESCRIPTION
1	2	040517000	DECAL STAY CLEAR OF BOOM
2	2	040518000	DECAL STAY CLEAR OF LOAD
3	2	040519000	DECAL DANGER SCISSOR POINT
4	2	040529000	DECAL DANGER "ELECTROCUTION HAZARD" POWER LINE
5	1	040579000	DECAL OPERATION INSTRUCTIONS
6	1	040580000	DECAL TRAINED OPERATOR
7	1	040587000	DECAL WARNING LOAD SENSOR
8	1	330622000	DECAL SERIAL NO
9	1	40619001	DECAL AUTO CRANE LOGO
10	1	320318000	DECAL ANGLE INDICATOR CS
11	1	320318001	DECAL ANGLE INDICATOR SS
12	1	320988005	DECAL 3203 LOAD CHART
13	2	320433100	DECAL, TRAVELING BLOCK 3203
14	2	320918000	DECAL 3203 HORIZONTAL
15	1	360034000	DECAL AUTO CRANE LOGO
16	2	600047000	DECAL AUTO CRANE
17	1	460169000	DECAL WARNING, REMOTE CONTROL
18	1	040632000	DECAL WARNING - OVERLOAD
19	1	040824000	DECAL, AMERICAN FLAG, MADE IN THE U.S.A.

3203PR/PRX GENERAL DIMENSIONS



3203PR/PRX

MOUNTING AND INSTALLATION

1. Check to make sure the following items are with your crane.

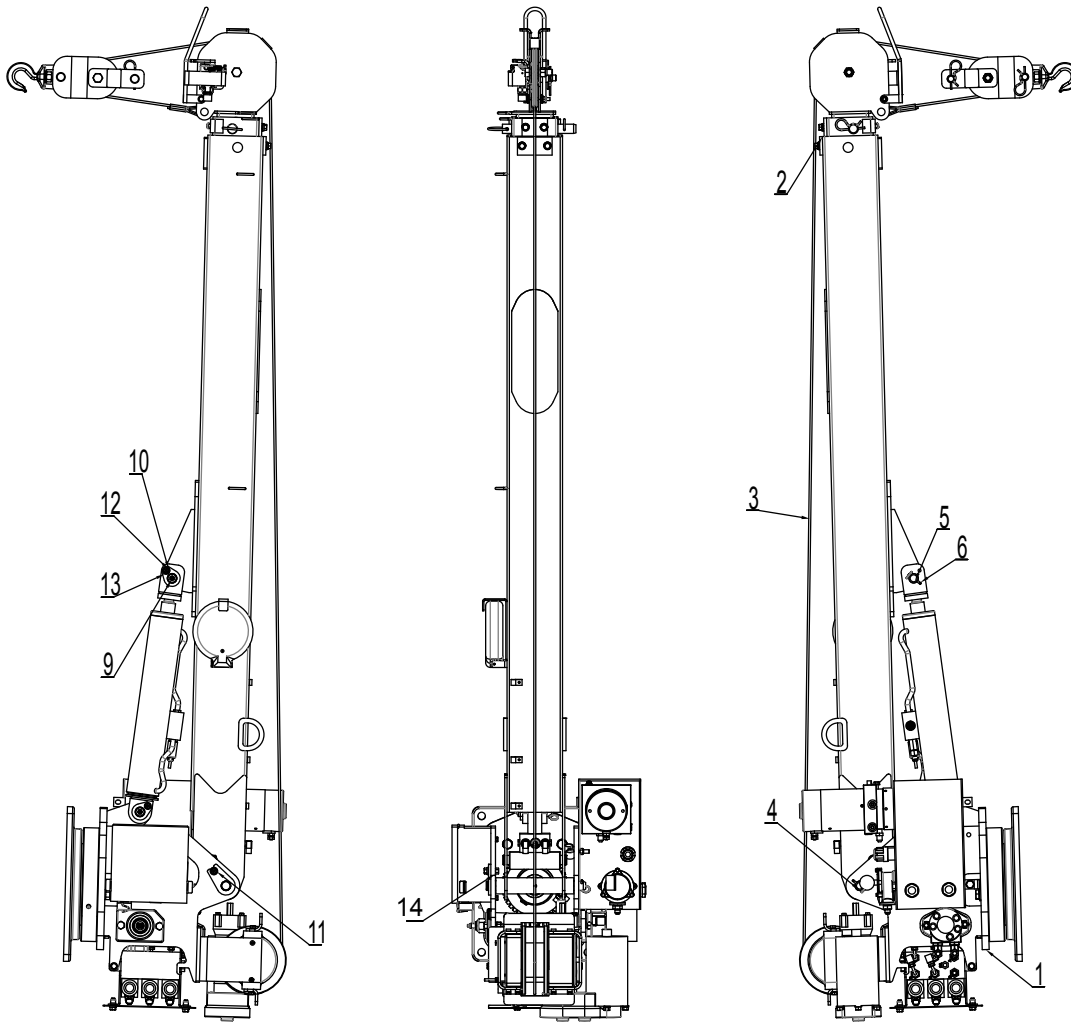
ITEM	QTY FM	QTY HW	PART NO	DESCRIPTION
1	1	1	320433000	TRAVELING BLOCK ASSY
2	6	6	083800000	CLIP, CABLE 3838 (FRAME)
3	4	4	404226000	SCREW, HS HD,, 3/4 - 16UNF X 3" LG GRADE 8
4	4	4	404227000	NUT HX 3/4 - 16 UNF
5		4	022101000	WASHER, SP. LK 3/4
6	8	4	022102000	WASHER FL 3/4
7	1	1	320950000	OWNER'S MANUAL (3203 PR/PRX/PRFX)
8	1	1	404223020	COND ASSY 4 GA X 48" BLK
9	1	1	404223010	CABLE PWR, 25 FT
10	1		460157000	TRANSMITTER
11	1		460159000	TETHER CABLE, TRANSMITTER
12	1	1	404218000	TWECO CABLE ASSY W/MASTER SWITCH
13		1	680179000	PENDANT ASSY

2. Vehicle should meet minimum GVW rating of 8,800pounds. (does not include bodies or accessories)
3. Make sure mounting surface is properly reinforced to withstand 12,000 ft-lb capacity loading of crane and that outriggers are used to provide total stability for the truck.
4. A 9" dia. hole should be cut out of mounting location (centered with mounting bolts) for access. Reference general dimensions for bolt pattern.
5. Make sure the mounting bolts are 3/4"-16UNF, grade 8UNF. Torque bolts to 335 ft-lbs (dry).
6. When crane is not in operation, a boom support should always be used. Traveling block should be connected to hook loop.
7. See the following page for installation.
8. See the following pages for additional electrical installation.
9. Load test the crane to ensure proper functioning and truck stability
10. Make certain the owner's manual is delivered to the customer.
11. For additional help: call the service department at the Auto Crane Company. (918) 836-0463 (Tulsa,Oklahoma)

WARNING

FEDERAL LAW (49 CFR PART 571) REQUIRES THAT THE FINAL STAGE MANUFACTURER OF A VEHICLE CERTIFY THAT HE VEHICLE COMPLIES WITH ALL APPLICABLE FEDERAL REGULATIONS. ANY MODIFICATIONS PERFORMED ON THE VEHICLE PRIOR TO THE FINAL STAGE ARE ALSO CONSIDERED INTERMEDIATE STAGE MANUFACTURING AND MUST BE CERTIFIED AS TO COMPLIANCE. THE INSTALLER OF THIS CRANE AND BODY IS CONSIDERED ONE OF THE MANUFACTURERS OF THE VEHICLE. AS SUCH A MANUFACTURER, THE INSTALLER IS RESPONSIBLE FOR COMPLIANCE WITH ALL APPLICABLE FEDERAL AND STATE REGULATIONS, AND IS REQUIRED TO CERTIFY THAT THE VEHICLE IS IN COMPLIANCE. IT IS THE FURTHER RESPONSIBILITY OF THE INSTALLER OF THE CRANE TO COMPLY WITH THE OSHA TRUCK CRANE STABILITY REQUIREMENTS AS SPECIFIED BY 29 CFR PART 1910.180 (C) (1).

GENERAL ASSEMBLY 3203PR CRANE

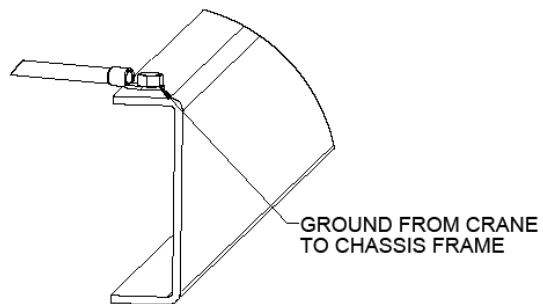
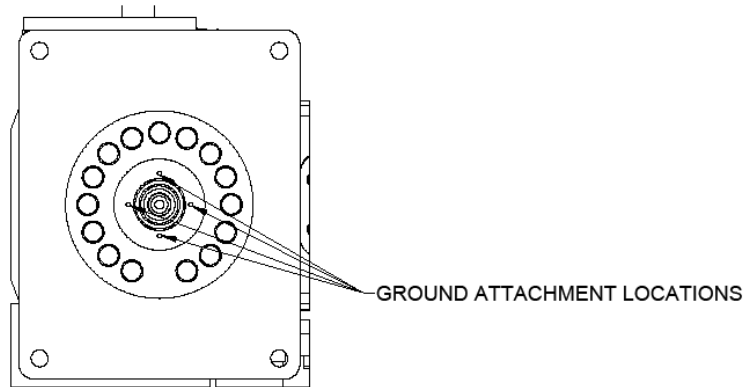


ITEM NO.	QTY.	PART NO.	DESCRIPTION
1	1	320988203	PEDESTAL ASSEMBLY, 3203 PRX
2	1	320988102	BOOM ASSY 3203 PRX
3	1	320338002	CABLE ASS'Y, 7/32" x 62FT, THIMBLE END
4	1	404220000	PIN WDMT BOOM/PED
5	1	320824000	PIN, LIFT CYLINDER
6	2	360678000	PIN, 3/16 COTTERLESS RING
7*	1	320988004	DECAL LAYOUT, 3203
8*	1	320988012	SHIP KIT, 3203 PR/PRX, HW
9	1	239300000	ZERK, GREASE
10	1	330371000	SCREW HX HD 3/8-16UNC X 1 LG GR8
11	1	366159000	SCREW HX HD 3/8-16UNC X 1 1/2 LG GR8
12	2	021100000	WASHER SP LK 3/8
13	2	021200000	WASHER FL 3/8
14	1	330372000	NUT HX 3/8-16UNC

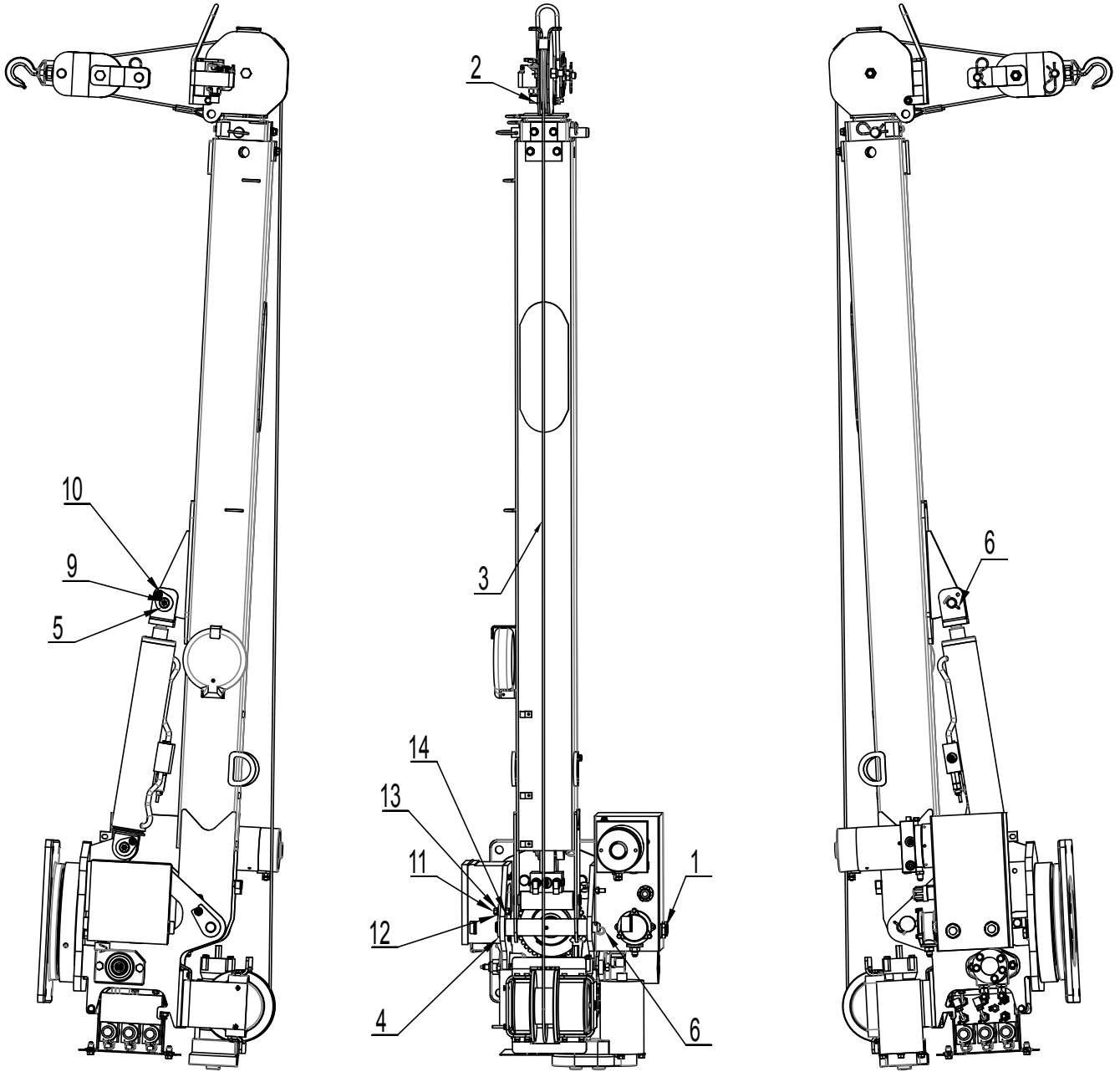
*NOT SHOWN FOR CLARITY

3203PR GENERAL ASSEMBLY HARDWIRED

Attach ground wire (404223020) to bottom of the crane. Run the ground wire down through the crane box. Locate cable so that it will be protected and avoid sharp edges. Attach ground from crane to chassis frame.



3203PRX GENERAL ASSEMBLY HARDWIRED - P/N:320989002

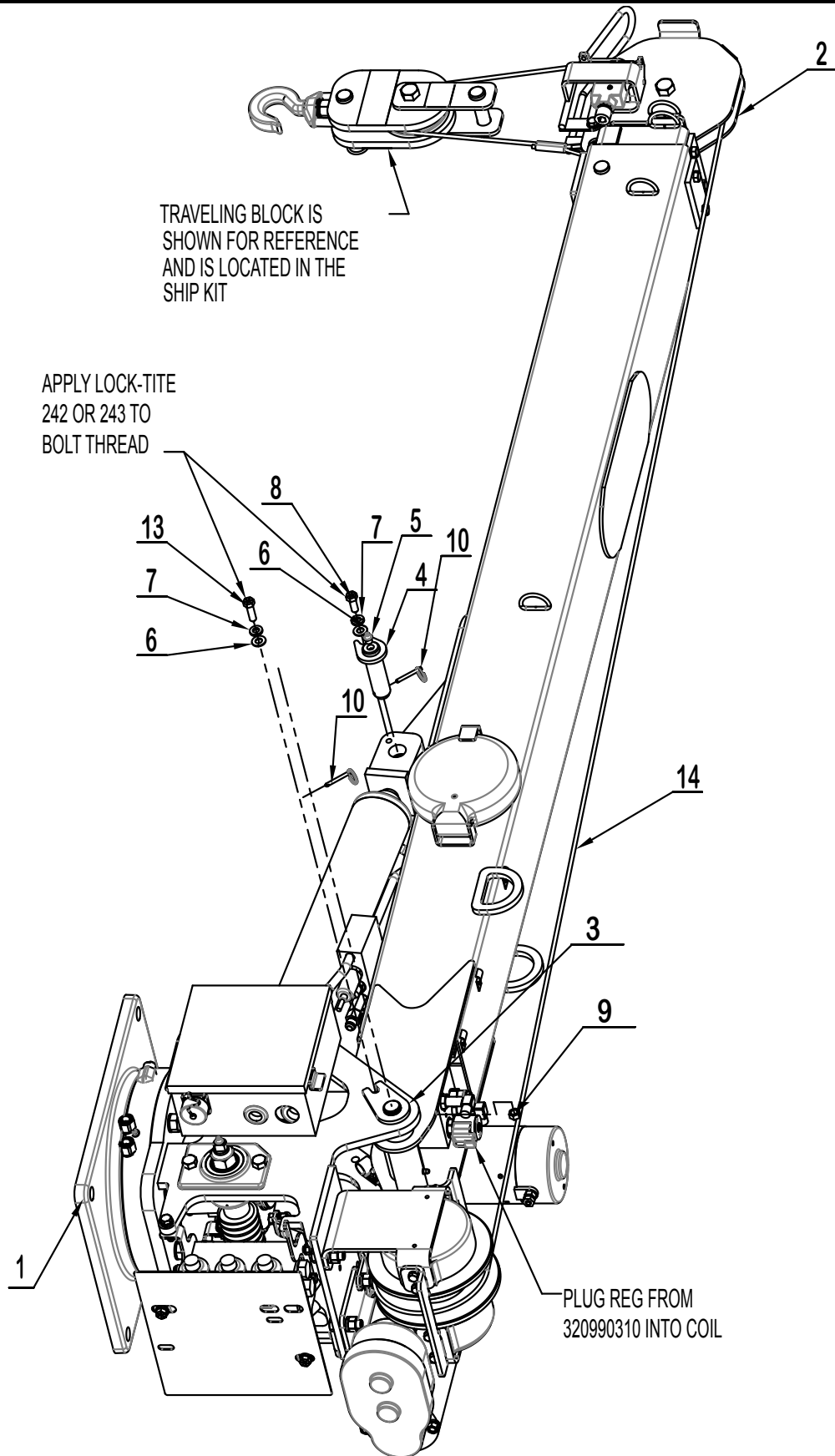


3203PRX GENERAL ASSEMBLY HARDWIRED-P/N:320989002

ITEM NO.	QTY	PART NUMBER	DESCRIPTION
1	1	320988203	PEDESTAL ASSEMBLY, 3203 PRX
2	1	320988102	BOOM ASSY 3203 PRX
3	1	320338002	CABLE ASS'Y, 7/32" x 62FT, THIMBLE END
4	1	404220000	PIN WDMT BOOM/PED
5	1	320824000	PIN, LIFT CYLINDER
6	2	360678000	PIN, 3/16 COTTERLESS RING
7*	1	320988004	DECAL LAYOUT, 3203
8*	1	320988012	SHIP KIT, 3203 PR/PRX, HW
9	1	239300000	ZERK, GREASE
10	1	330371000	SCREW HX HD 3/8-16UNC X 1 LG GR8
11	1	366159000	SCREW HX HD 3/8-16UNC X 1 1/2 LG GR8
12	2	021100000	WASHER SP LK 3/8
13	2	021200000	WASHER FL 3/8
14	1	330372000	NUT HX 3/8-16UNC

* NOT SHOWN FOR CLARITY

3203PRFX GENERAL ASSEMBLY HARDWIRED - P/N: 320990001



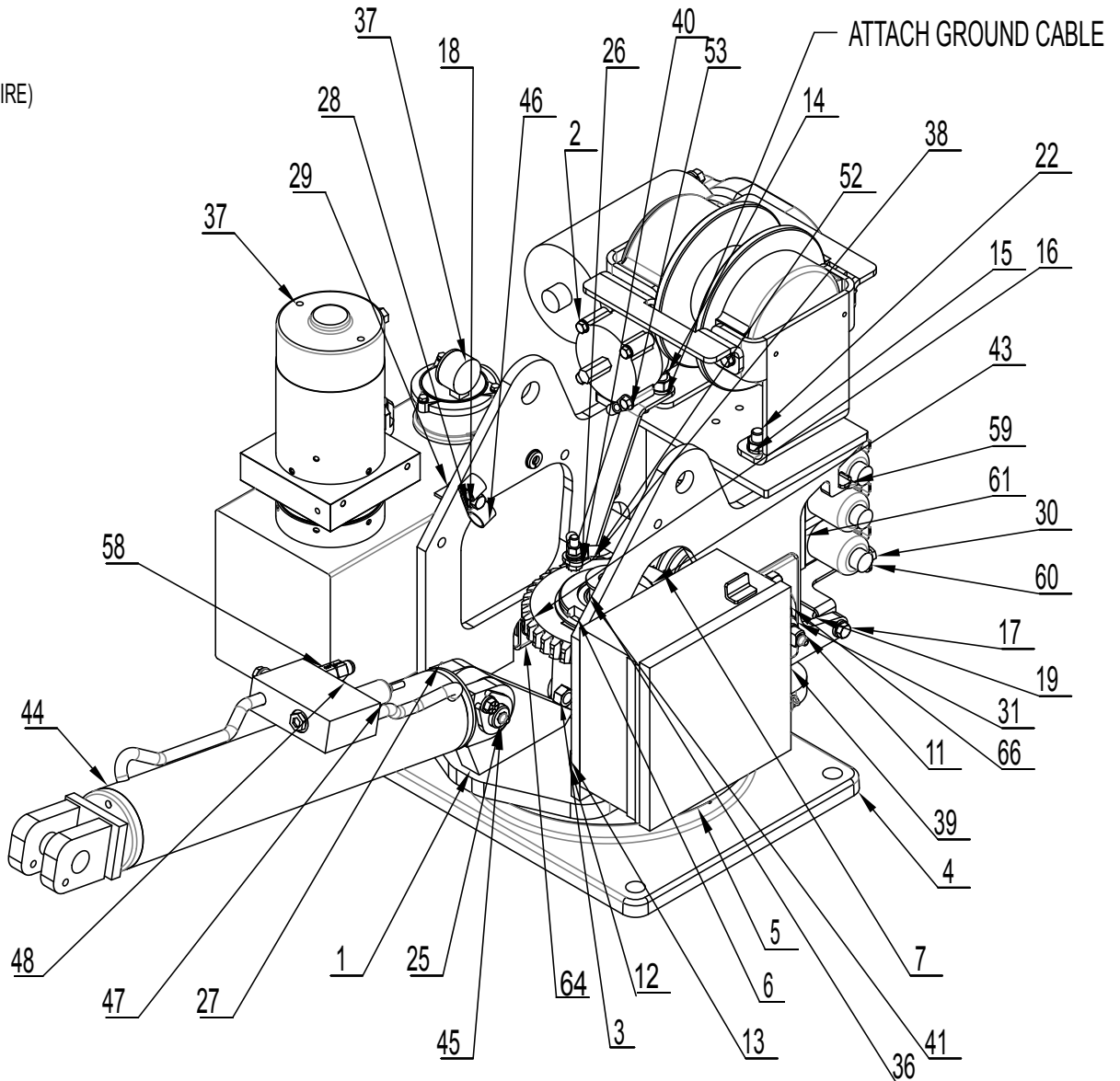
**3203PRFX GENERAL ASSEMBLY
HARDWIRED - P/N: 320990001**

ITEM NO.	QTY	PART NO.	DESCRIPTION
1	1	320990200	PEDESTAL ASSEMBLY, 3203 PRFX
2	1	320990100	BOOM ASSY 3203PRFX
3	1	404220000	PIN WDMT BOOM/PED
4	1	320824000	PIN, LIFT CYLINDER
5	1	239300000	ZERK, GREASE
6	2	021200000	WASHER FL 3/8
7	2	021100000	WASHER SP LK 3/8
8	1	330371000	SCREW HX HD 3/8-16UNC X 1 LG GR8
9	1	330372000	NUT HX 3/8-16UNC
10	2	360678000	PIN, 3/16 COTTERLESS RING
11*	1	320988012	SHIP KIT, 3203 PR/PRX, HW
12*	1	320988004	DECAL LAYOUT, 3203
13	1	366159000	SCREW HX HD 3/8-16UNC X 1 1/2 LG GR8
14	1	320338002	CABLE ASS'Y, 7/32" x 62FT, THIMBLE END
* ITEM NOT SHOWN			

3203PR PEDESTAL ASSEMBLY

P/N: 320988204

ATTACH GROUND
CABLES FROM:
HOIST (600317)
PUMP (600318)
RELAY PANEL (BLACK WIRE)



HYDRAULICS:

PORT A-1 BOOM UP

PORT A-2 CCW BOTTOM MOTOR PORT

PORT B-1 BOOM DOWN

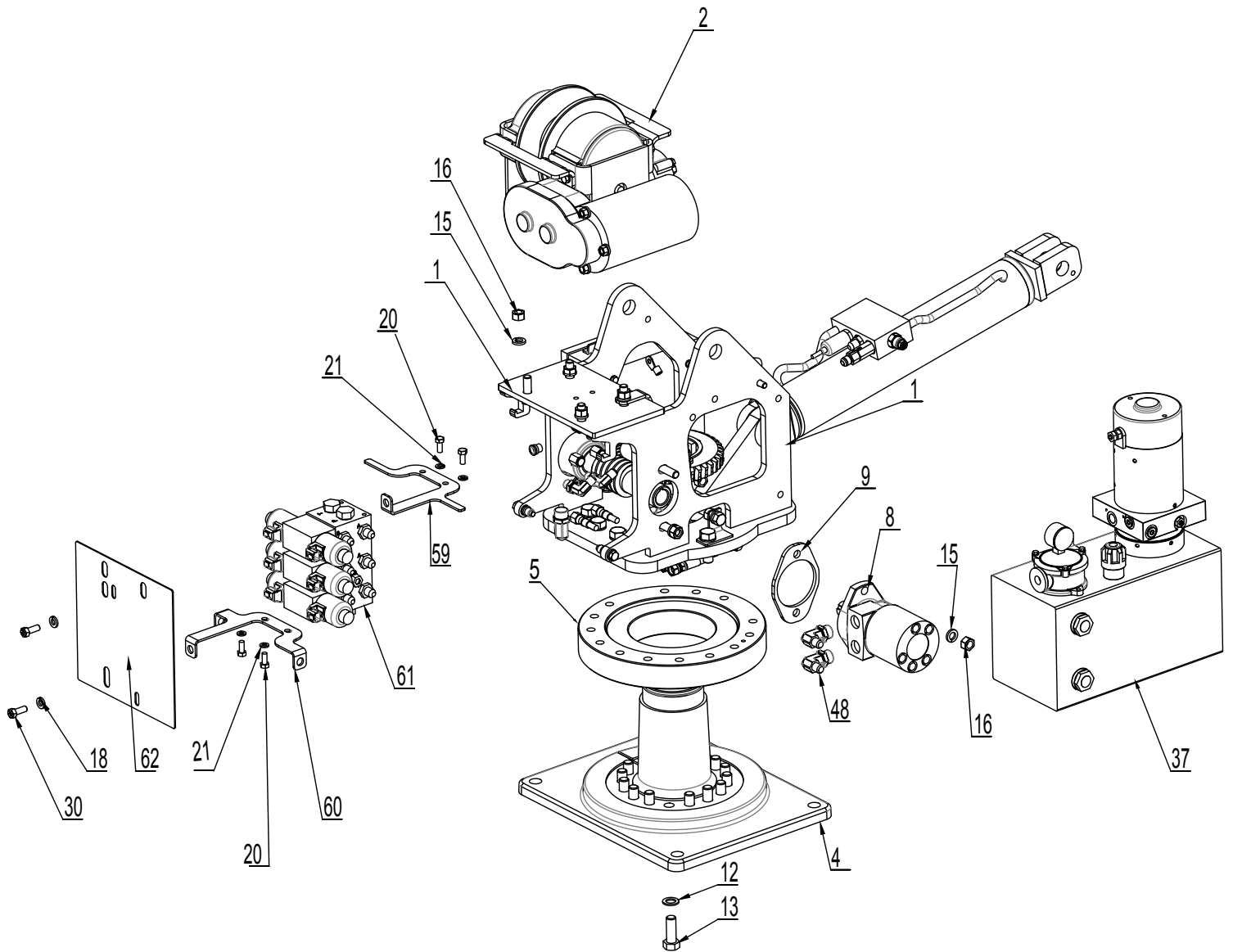
PORT B-2 CW TOP MOTOR PORT

CYLINDER SEAL KIT: 320845002

C'BAL CARTRIDGE: 480188000

3203PR PEDESTAL ASSEMBLY

P/N: 320988204



3203PR PEDESTAL ASSEMBLY

P/N 320988204

ITEM NO.	QTY	PART NO.	DESCRIPTION
1	1	320988210	PEDESTAL WELDMENT, 3203 PR / PRX / H
2	1	110703	WINCH-DCG8R FOR AUTOCRANE #3203 PRX
3	1	320991240	KIT, HOSE NEXSTAR 3203PRX/4004EH
4	1	320991237	BASE PLATE MACH 3203 LESS GROUND HOLE
5	1	320878000	ROTATION BEARING
6	1	340602000	KEY, 3/4 SQ X 1
7	1	320988253	GEAR, WORM, 4.00 ID, .75 KEY, 3203
8	1	404241285	MOTOR, HYD 8.0 CU IN, SAE 2-BOLT 1" SHAFT
9	1	320879000	SPACER ROTATION
10	1	330483000	SPACER
11	1	404015	WORM SHAFT
12	22	023902000	WASHER FL 5/8 HARDENED
13	22	012198000	SCREW HX HD 5/8-11UNC X 1 3/4 LG GR8
14	6	011603000	SCREW HX HD 1/2-13UNC X 1 3/4 LG
15	10	021500000	WASHER, SP LK 1/2
16	10	017701000	NUT HX 1/2-13UNC
17	2	009109000	SCREW HX HD 3/8-16UNC X 1 1/2 LG
18	7	021100000	WASHER SP LK 3/8
19	4	736274000	NUTSERT 3/8-16UNC X .027-.15 GRIP
20	4	330252000	SCREW HX HD 5/16-18UNC X 3/4 LG GR5
21	4	020601000	WASHER SP LK 5/16
22	3	010201000	SCREW HX HD 1/2-13UNC x 1 1/2 LG
23	4	006200000	SCREW HX HD 1/4-20UNC X 1 1/4 LG
24	4	020200000	WASHER SP LK 1/4
25	2	239300000	ZERK, GREASE
26	2	330372000	NUT HX 3/8-16UNC
27	1	360678000	PIN, 3/16 COTTERLESS RING
28	2	021200000	WASHER FL 3/8
29	1	330394000	SCREW HX HD 3/8-16UNC X 1 1/2 LG
30	3	330371000	SCREW HX HD 3/8-16UNC X 1 LG GR8
31	1	019000000	NUT HX NYLK 7/8-14UNF
32*	2	812026016	HOSE ASSY -4 HOSE -6 FEMALE JIC
33*	1	812209023	HOSE ASSY, SHORT, 23"

3203PR PEDESTAL ASSEMBLY

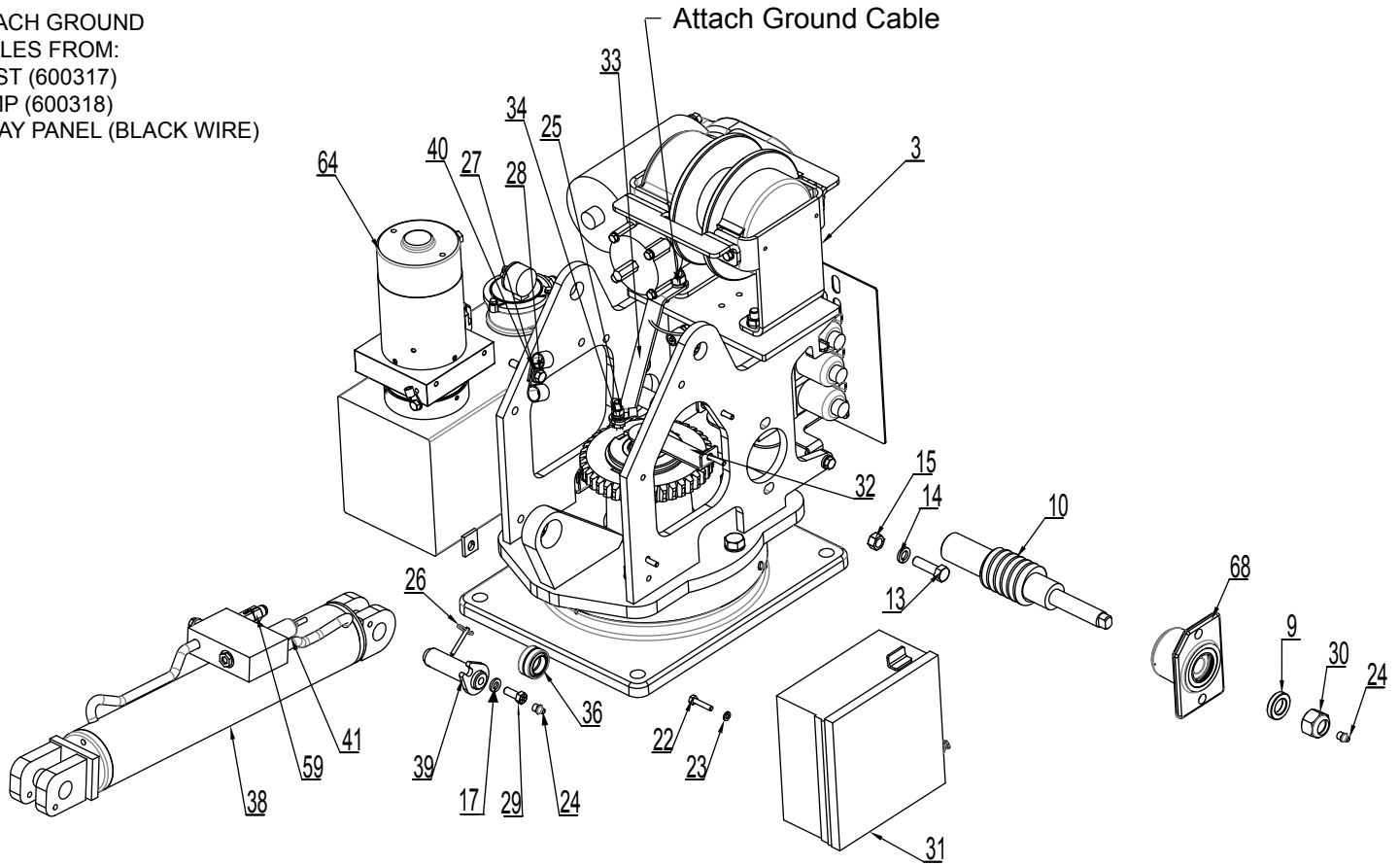
P/N 320988204

ITEM NO.	QTY	PART NO.	DESCRIPTION
34*	1	812209028	HOSE ASSY, SHORT, 28"
35	1	202756000	ADAPTER, STRAIGHT 8SAE(M)-6JIC(M)
36	1	320988258	UPPER TWECO BRACKET WLDMT, 3203
37	1	320991279	POWER UNIT, ENTRY LEVEL 3203/4004 EH
38	1	404187000	SPRING PLATE, GROUND BRUSH, 4004
39*	1	320988300	RELAY PANEL ASSEMBLY, 3203
40	1	404198000	SCREW HX HD 3/8-16UNC X 1 1/2 LG, BRONZE
41	1	404213000	SEAL, 2.50 OD X 1.5 ID
42	1	320858000	BEARING, SPHERICAL 1.00 ID
43	1	404028000	RETAINING RING, SNAP RING
44	1	320845000	CYLINDER, LIFT
45	1	320824000	PIN, LIFT CYLINDER
46	2	480024000	MOUNT PENDANT CABLE RETAINER
47	1	320917000	PRESSURE SWITCH, N.C. 1,900 PSI
48*	1	200876000	FITTING 6 SAE/6 JIC STRAIGHT
49*	3	490198000	FITTING 10SAE(M)/6JIC ELBOW 90
50	1	320988270	KIT, HYDRAULIC, 3203 PR
51	1	680156100	KIT-ELECTRICAL, 3203 PR/PRX
52	2	002901000	TERMINAL, RING #4 - 3/8
53	1	002702000	TERMINAL, RING #4 - 5/16
54*	1	660116000	CABLE ASSY, 6 AWG, 16 1/4 " WIRE LGTH
55*	1	600318000	CABLE ASSY, 6 AWG, 11" WIRE LGTH
56	1	002900000	SCREW SET 0.25-20 X 0.25
57*	1	645000000	TWECO, MALE MODIFIED
58	1	320988261	VALVE, FLOW REGULATOR, IN-LINE
59	1	320989204	UPPER VALVE BRACKET, 3203H
60	1	320989203	LOWER VALVE BRACKET, 3203H
61	1	320989420	VALVE ASSY, 3 SPOOL, NON-PROP., 12 VOLT
62	1	366688000	COVER, REAR
63*	2	360447000	FITTING, CAP, JIC, -6
64	1	320989235	BRACKET, POWER UNIT
65*	2	480194000	FITTING 6JIC/6JIC ELBOW 90
66	1	330478000	BEARING HOUSING ASSY
*	ITEMS NOT SHOWN		

3203PRX PEDESTAL ASSEMBLY

P/N: 320988203

ATTACH GROUND
 CABLES FROM:
 HOIST (600317)
 PUMP (600318)
 RELAY PANEL (BLACK WIRE)

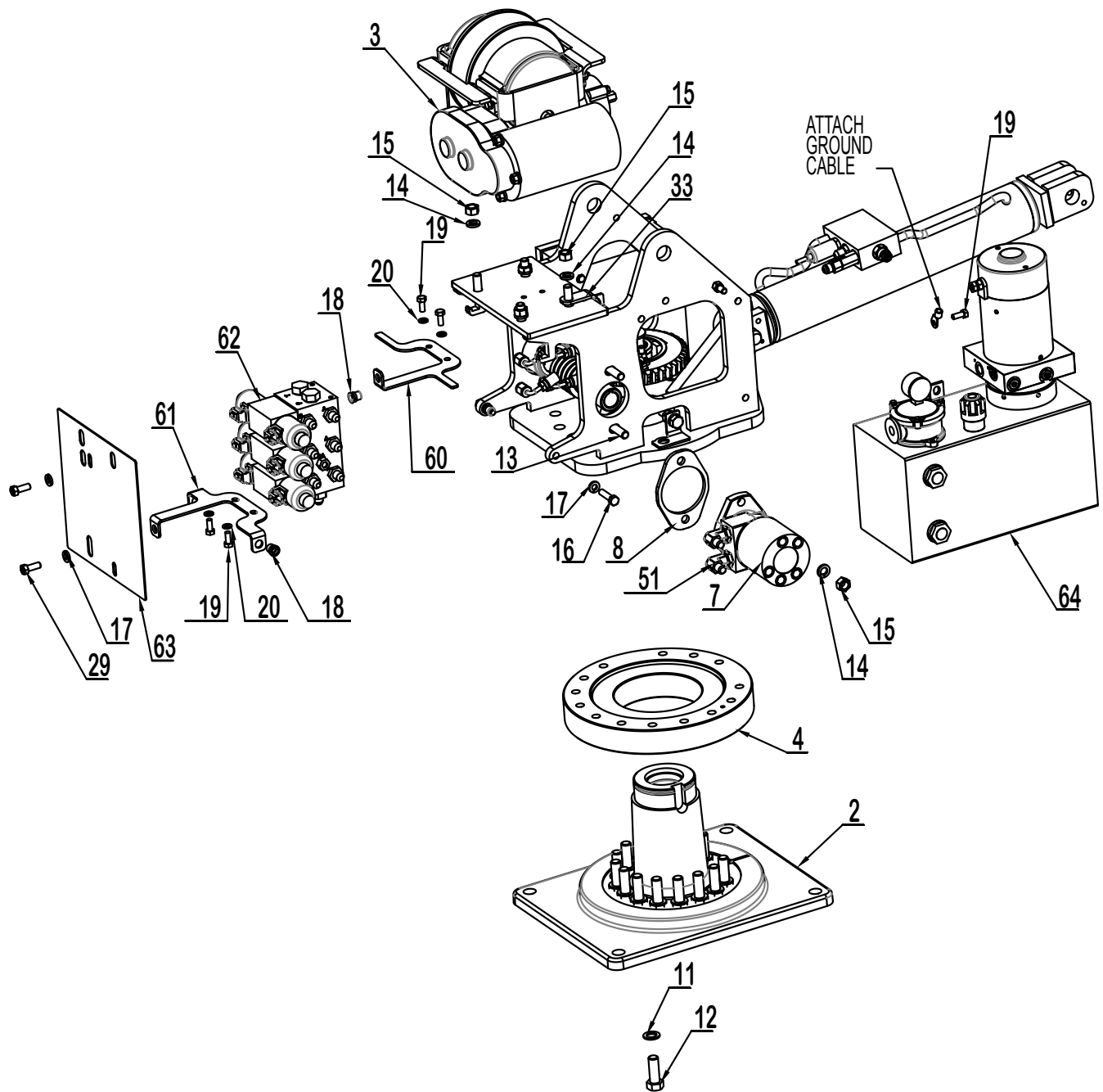


HYDRAULICS:
 PORT A-1 RETRACT
 PORT A-2 BOOM DOWN
 PORT A-3 CCW BOTTOM MOTOR PORT
 PORT B-1 EXTEND
 PORT B-2 BOOM UP
 PORT B-3 CW TOP MOTOR PORT

CYLINDER SEAL KIT: 320845002
C'BAL CARTRIDGE: 480188000

3203PRX PEDESTAL ASSEMBLY

P/N: 320988203



3203PRX PEDESTAL ASSEMBLY

P/N 320988203

ITEM NO	QTY	PART NO.	DESCRIPTION
1	1	320988210	PEDESTAL WELDMENT, 3203 PR / PRX / H
2	1	320991237	BASE PLATE MACH 3203 LESS GROUND HOLE
3	1	110703	WINCH-DCG8R FOR AUTOCRANE #3203 PRX
4	1	320878000	ROTATION BEARING
5	1	340602000	KEY, 3/4 SQ X 1
6	1	320988253	GEAR, WORM, 4.00 ID, .75 KEY, 3203
7	1	404241285	MOTOR, HYD 8.0 CU IN, SAE 2-BOLT 1" SHAFT
8	1	320879000	SPACER ROTATION
9	1	330483000	SPACER
10	1	404015000	WORM SHAFT
11	24	023902000	WASHER FL 5/8 HARDENED
12	24	012198000	SCREW HX HD 5/8-11UNC X 1 3/4 LG GR8
13	6	011603000	SCREW HX HD 1/2-13UNC X 1 3/4 LG B
14	10	021500000	WASHER, SP LK 1/2
15	9	017701000	NUT HX 1/2-13UNC
16	2	009109000	SCREW HX HD 3/8-16UNC X 1 1/2 LG
17	5	021100000	WASHER SP LK 3/8
18	4	736274000	NUTSERT 3/8-16UNC X .027-.15 GRIP
19	5	330252000	SCREW HX HD 5/16-18UNC X 3/4 LG GR5
20	4	020601000	WASHER SP LK 5/16
21	3	010201000	SCREW HX HD 1/2-13UNC x 1 1/2 LG
22	4	006200000	SCREW HX HD 1/4-20UNC X 1 1/4 LG
23	4	0202000000	WASHER SP LK 1/4
24	2	239300000	ZERK, GREASE
25	2	330372000	NUT HX 3/8-16UNC
26	1	360678000	PIN, 3/16 COTTERLESS RING
27	1	320976000	WASHER, FLAT, 3/8 SAE HARDENED
28	1	09116000	SCREW HX HD 3/8-16UNC X 2 GR5
29	3	330371000	SCREW HX HD 3/8-16UNC X 1 LG GR8
30	1	019000000	NUT HX NYLK 7/8-14UNF
31	1	320988300	RELAY PANEL ASSEMBLY, 3203
32	1	320988258	UPPER TWECO BRACKET WLDMT, 3203
33	1	404187000	SPRING PLATE, GROUND BRUSH, 4004
34	1	404198000	SCREW HX HD 3/8-16UNC X 1 1/2 LG, BRONZE

3203PRX PEDESTAL ASSEMBLY

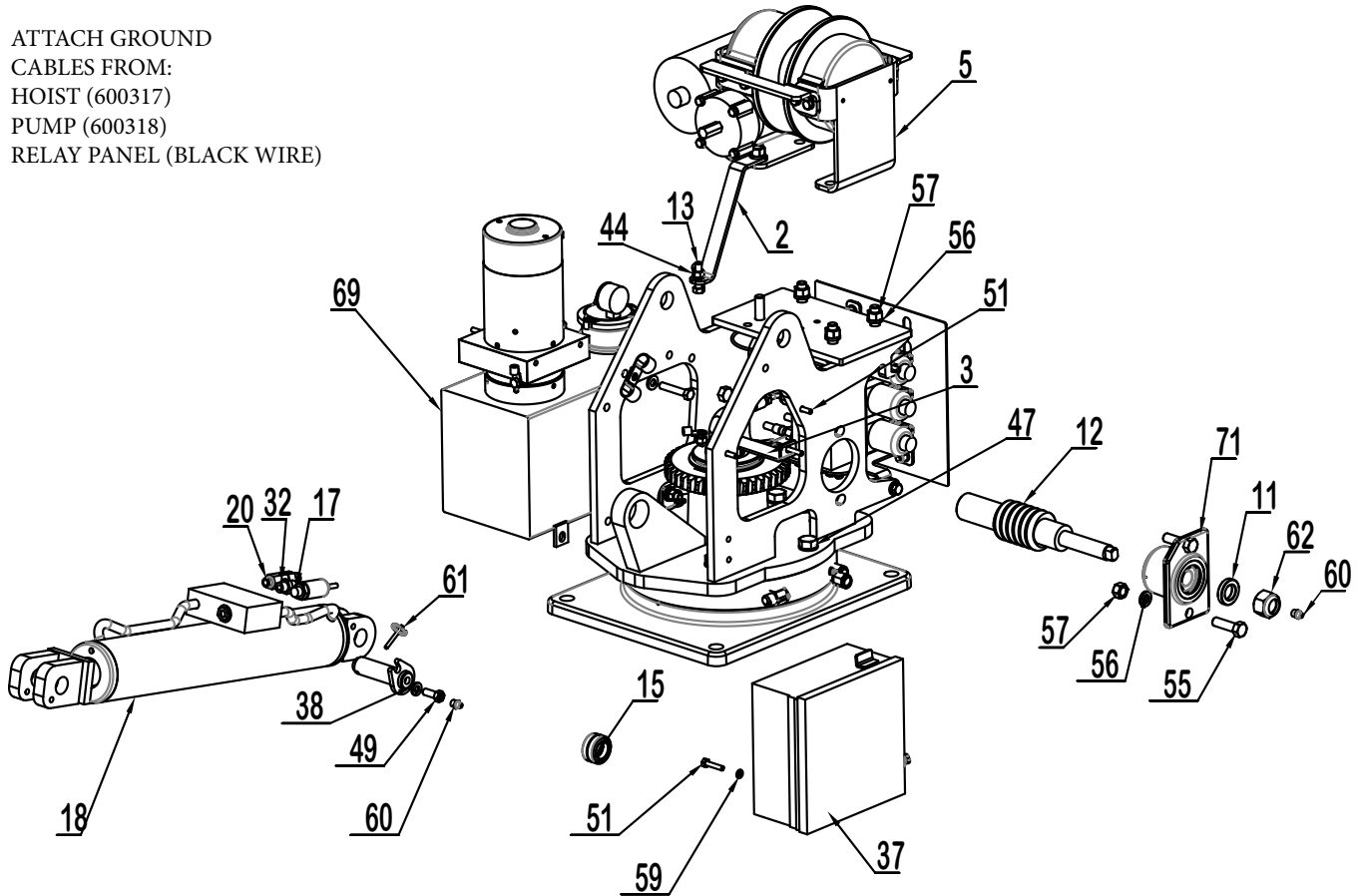
P/N 320988203

ITEM NO	QTY	PART NO.	DESCRIPTION
35	1	404213000	SEAL, 2.50 OD X 1.5 ID
36	1	320858000	BEARING, SPHERICAL 1.00 ID
37	1	404028000	RETAINING RING, SNAP RING
38	1	320845000	CYLINDER, LIFT
39	1	320824000	PIN, LIFT CYLINDER
40	2	480024000	MOUNT PENDANT CABLE RETAINER
41	1	320917000	PRESSURE SWITCH, N.C. 1,900 PSI
42	16	374085000	NYLON HOSE SLEEVE
43	1	812209028	HOSE ASSY, -6 HOSE, -6 JICF / -6 JICF 90DEG
44	1	812209023	HOSE ASSY, -6 HOSE, -6 JICF / -6 JICF 90DEG
45	2	812037018	HOSE ASSEMBLY, -6 JIC 90/-4 HOSE
46	1	812037031	HOSE ASSY, -6 JICF/ -6 90 DEG ELL, -4 HOSE x
47	1	812037027	HOSE ASSY, -6 JICF/ -6 90 DEG ELL, -4 HOSE x
48	2	812026016	HOSE ASSY -4 HOSE -6 FEMALE JIC
49	1	202756000	ADAPTER, STRAIGHT 8SAE(M)-6JIC(M)
50	2	200876000	FITTING 6 SAE/6 JIC STRAIGHT
51	2	490198000	FITTING 10SAE(M)/6JIC ELBOW 90
52	1	320988251	KIT, HYDRAULIC, 3203 PRX/ 4004
55	1	660116000	CABLE ASSY, 6 AWG, 16 1/4" WIRE LGTH, ø3/8
56	1	600318100	CABLE ASSY, 6 AWG, 24" WIRE LGTH, ø3/8 TMNL, ø
57	1	002900000	SCREW SET 0.25-20 X 0.25
58	1	645000000	TWECO, MALE MODIFIED
59	1	320988261	VALVE, FLOW REGULATOR, IN-LINE
60	1	320989204	UPPER VALVE BRACKET, 3203H
61	1	320989203	LOWER VALVE BRACKET, 3203H
62	1	320989420	VALVE ASSY, 3 SPOOL, NON-PROP., 12 VOLT
63	1	366688000	COVER, REAR
64	1	320991279	POWER UNIT, ENTRY LEVEL 3203/4004 EH B
65	1	320989235	BRACKET, POWER UNIT
66	1	680156100	KIT-ELECTRICAL, 3203 PR/PRX
67	1	017301000	NUT HX NYLK 3/8-16UNC CP
68	1	330478000	BEARING HOUSING ASSY

3203PRFX PEDESTAL ASSEMBLY

P/N: 320990200

ATTACH GROUND
 CABLES FROM:
 HOIST (600317)
 PUMP (600318)
 RELAY PANEL (BLACK WIRE)

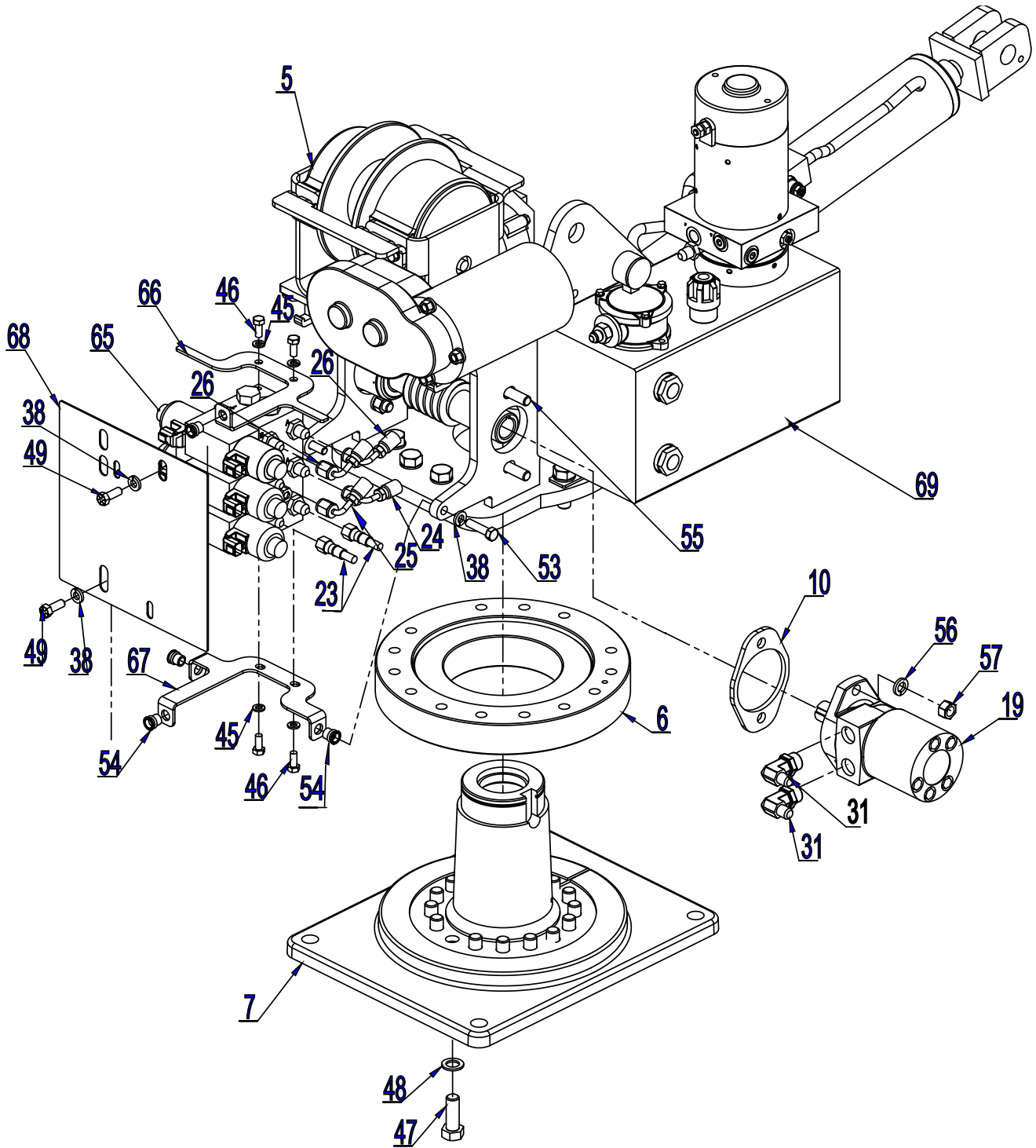


HYDRAULICS:
 PORT A-1 RETRACT
 PORT A-2 BOOM DOWN
 PORT A-3 CCW BOTTOM MOTOR PORT
 PORT B-1 EXTEND
 PORT B-2 BOOM UP
 PORT B-3 CW TOP MOTOR PORT

CYLINDER SEAL KIT: 320845002
 C'BAL CARTRIDGE: 480188000

3203PRFX PEDESTAL ASSEMBLY

P/N: 320990200



3203PRFX PEDESTAL ASSEMBLY

P/N: 320990200

ITEM NO.	QTY	PART NUMBER	DESCRIPTION
1	2	320991240	KIT, HOSE NEXSTAR 3203PRX/4004EH
2	1	404187000	SPRING PLATE, GROUND BRUSH, 4004
3	1	320988258	UPPER TWECO BRACKET WLDMT, 3203
4	1	320988210	PEDESTAL WELDMENT, 3203 PR / PRX / H
5	1	110703	WINCH-DCG8R FOR AUTOCRANE #3203 PRX
6	1	320878000	ROTATION BEARING
7	1	320991237	BASE PLATE MACH 3203 LESS GROUND HOLE
8	1	340602	KEY, 3/4 SQ X 1
9	1	320988253	GEAR, WORM, 4.00 ID, .75 KEY, 3203
10	1	320879000	SPACER ROTATION
11	1	330483	SPACER
12	1	404015	WORM SHAFT
13	1	404198000	SCREW HX HD 3/8-16UNC X 1 1/2 LG, BRONZE
14	1	404213000	SEAL, 2.50 OD X 1.5 ID
15	1	320858000	BEARING, SPHERICAL 1.00 ID
16	1	320824000	PIN, LIFT CYLINDER
17	1	320917000	PRESSURE SWITCH, N.C. 1,900 PSI
18	1	320845000	CYLINDER, LIFT
19	1	404241285	MOTOR, HYD 8.0 CU IN, SAE 2-BOLT 1" SHAFT
20	1	320988261	VALVE, FLOW REGULATOR, IN-LINE
21*	1	812209028	HOSE ASSY, -6 HOSE, -6 JICF / -6 JICF 90DEG SHORT, 28" LONG
22*	1	812209023	HOSE ASSY, -6 HOSE, -6 JICF / -6 JICF 90DEG SHORT, 23" LONG
23*	2	812026016	HOSE ASSY -4 HOSE -6 FEMALE JIC
24*	1	812037027	HOSE ASSY, -6 JICF / -6 90 DEG ELL, -4 HOSE x 27" LG
25*	1	812037031	HOSE ASSY, -6 JICF / -6 90 DEG ELL, -4 HOSE x 31" LG
26*	2	812037018	HOSE ASSEMBLY, -6 JIC 90/-4 HOSE
27*	16	374085000	NYLON HOSE SLEEVE
28*	1	480194000	FITTING 6JIC/6JIC ELBOW 90
29*	1	202756000	ADAPTER, STRAIGHT 8SAE(M)-6JIC(M)
30	1	320988251	KIT, HYDRAULIC, 3203 PRX/ 4004
31*	2	490198	FITTING 10SAE(M)/6JIC ELBOW 90
32*	2	200876	FITTING 6 SAE/6 JIC STRAIGHT
33	1	680156100	KIT-ELECTRICAL, 3203 PR/PRX
34**	1	660116000	CABLE ASSY, 6 AWG, 16 1/4" WIRE LGTH, ø3/8 TMNL, ø5/16 TMNL
35**	1	600318100	CABLE ASSY, 6 AWG, 24" WIRE LGTH, ø3/8 TMNL, ø5/16 TMNL

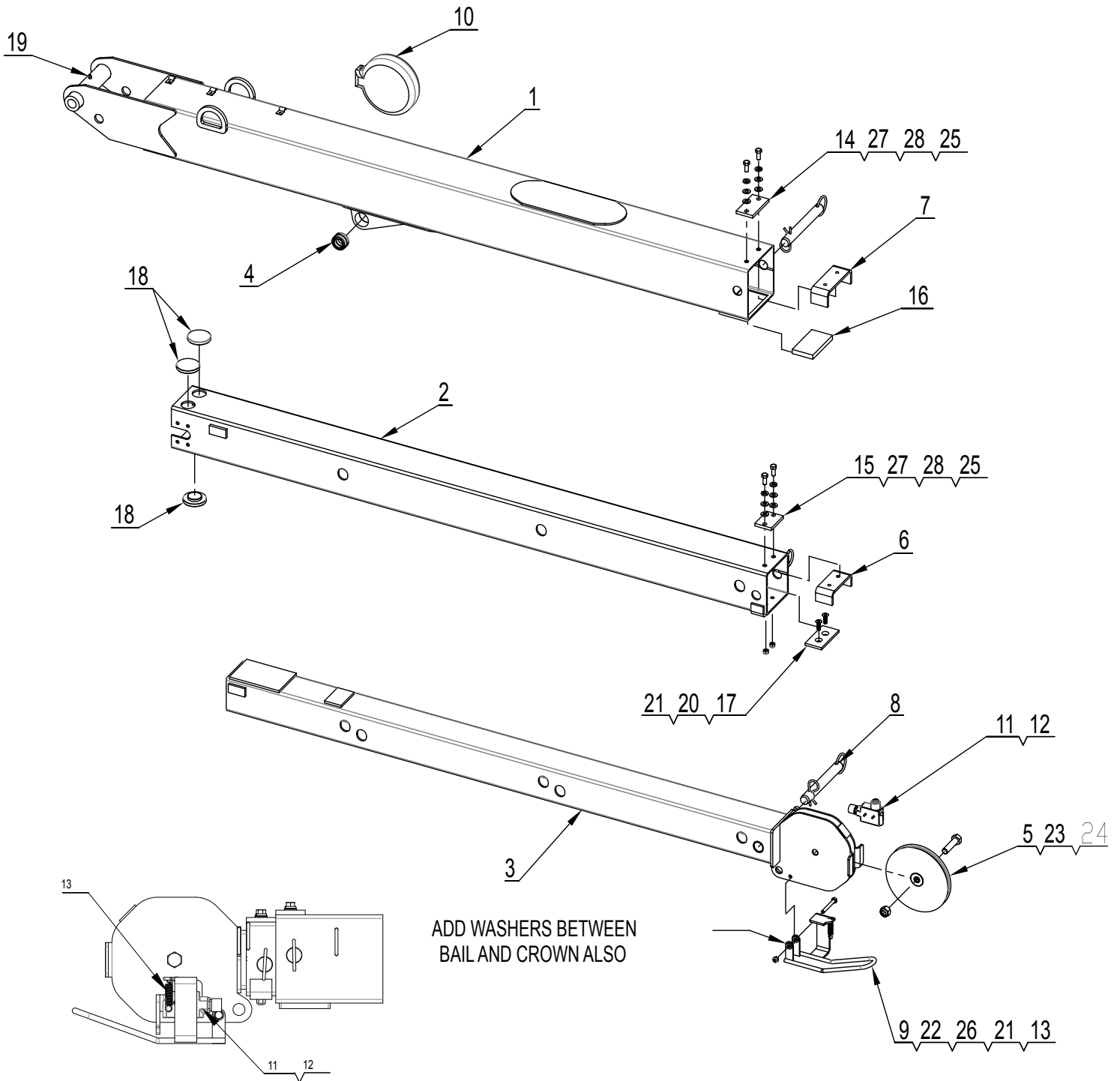
3203PRFX PEDESTAL ASSEMBLY

P/N: 320990200

ITEM NO.	QTY	PART NUMBER	DESCRIPTION
36**	1	645000000	TWECO, MALE MODIFIED
37**	1	320988300	RELAY PANEL ASSEMBLY, 3203
38	6	021100000	WASHER SP LK 3/8
39	1	017301000	NUT HX NYLK 3/8-16UNC CP
40	2	320976000	WASHER, FLAT, 3/8 SAE HARDENED
41	1	8702000	SCREW HX HD 3/8-16UNC X 1 1/4 LG GR5
42	1	009116000	SCREW HX HD 3/8-16UNC X 2 GR5
43	2	480024000	MOUNT PENDANT CABLE RETAINER
44	3	330372000	NUT HX 3/8-16UNC
45	4	020601000	WASHER SP LK 5/16
46	5	330252000	SCREW HX HD 5/16-18UNC X 3/4 LG GR5
47	23	012198000	SCREW HX HD 5/8-11UNC X 1 3/4 LG GR8
48	23	023902000	WASHER FL 5/8 HARDENED
49	3	330371000	SCREW HX HD 3/8-16UNC X 1 LG GR8
50	1	002900000	SCREW SET 0.25-20 X 0.25
51	4	006200000	SCREW HX HD 1/4-20UNC X 1 1/4 LG
52	1	404028000	RETAINING RING, SNAP RING
53	2	09109000	SCREW HX HD 3/8-16UNC X 1 1/2 LG
54	4	736274000	NUTSERT 3/8-16UNC X .027-.15 GRIP
55	5	011603000	SCREW HX HD 1/2-13UNC X 1 3/4 LG
56	8	021500000	WASHER, SP LK 1/2
57	8	017701000	NUT HX 1/2-13UNC
58	3	010201000	SCREW HX HD 1/2-13UNC x 1 1/2 LG
59	4	020200000	WASHER SP LK 1/4
60	2	023930000	ZERK, GREASE
61	1	360678000	PIN, 3/16 COTTERLESS RING
62	1	019000000	NUT HX NYLK 7/8-14UNF
63	1	320990310	HARNESS, WIRE, REGENERATIVE CIRCUIT, 3203PRFX
64	1	320990201	PRESSURE SWITCH, NC, 1450 PSI, 10 AMP
65	1	320989420	VALVE ASSY, 3 SPOOL, NON-PROP., 12 VOLT
66	1	320989204	UPPER VALVE BRACKET, 3203H
67	1	320989203	LOWER VALVE BRACKET, 3203H
68	1	366688000	COVER, REAR
69	1	320991279	POWER UNIT, ENTRY LEVEL 3203/4004 EH
70	1	320989235	BRACKET, POWER UNIT
71	1	330478000	BEARING HOUSING ASSY
* HYDRAULIC KIT 320988251			
** ELECTRICAL KIT 680156100			

3203PR BOOM ASSEMBLY

P/N: 320988103



NOTE:

APPLY LOCTITE 242 TO BOLT THREADS.

8 PLC'S BEFORE INSTALLING

CYLINDER SEAL KIT: 320835002

C'BAL CARTRIDGE: 480188000

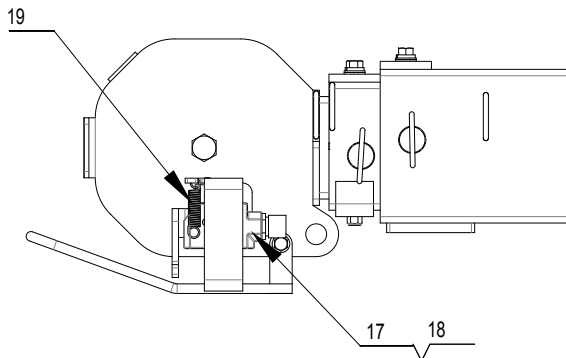
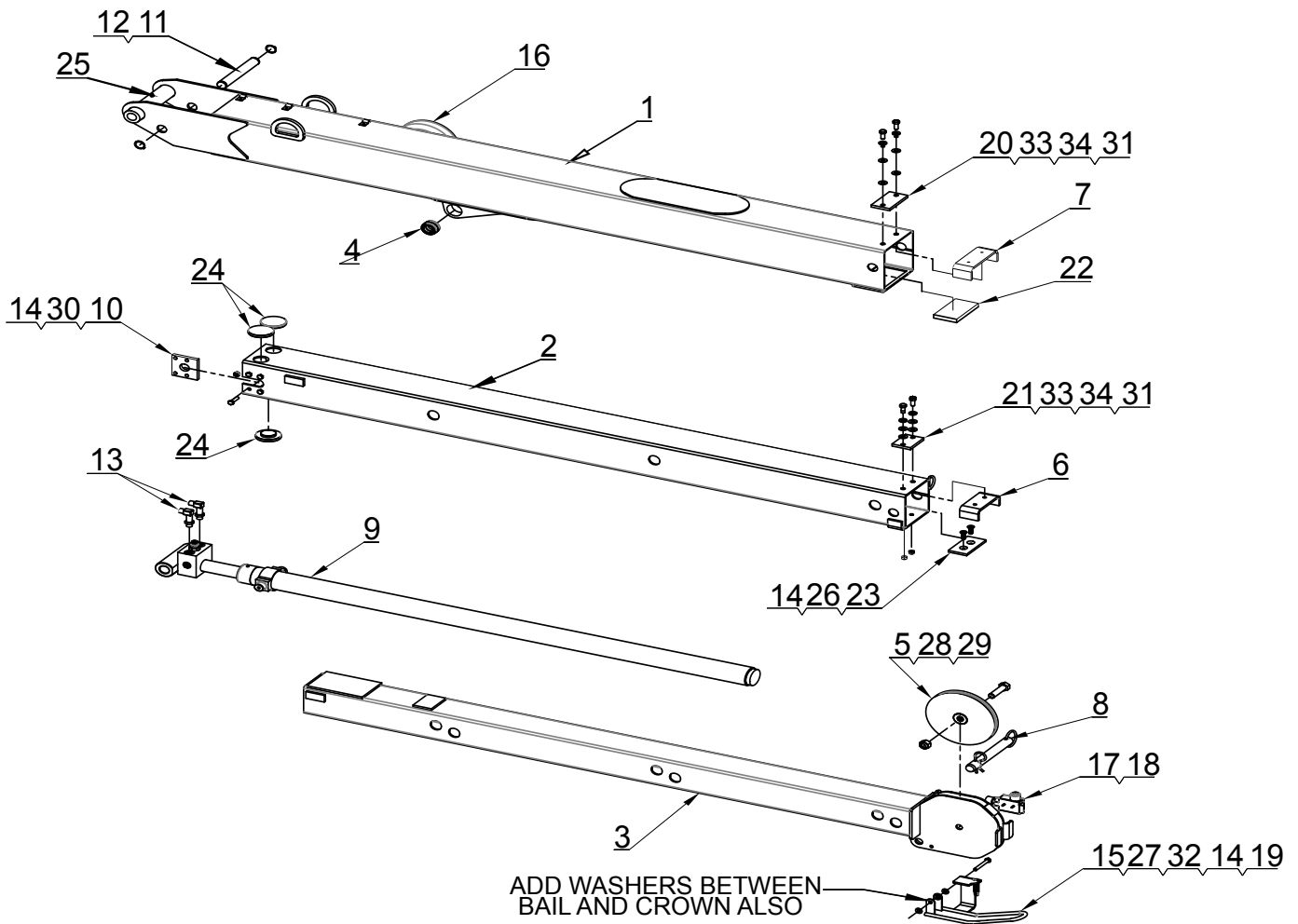
3203PR BOOM ASSEMBLY

P/N: 320988103

ITEM NO.	QTY.	PART NUMBER	DESCRIPTION
1	1	320988110	LOWER BOOM WELDMENT, 3203 PR/PRX
2	1	320988165	MID BOOM WMT, 3203
3	1	320988160	UPPER BOOM WLDMT 3203
4	1	320858000	BEARING, SPHERICAL 1.00 ID
5	1	320883000	SHEAVE ASSEMBLY
6	1	366112000	STOP UPPER BOOM
7	1	366183000	STOP CENTER BOOM
8	2	366190000	PIN ASSY W/LANYARD
9	1	320871000	BAIL WELDMENT
10	1	404205000	CORD REEL ASSY
11	1	646900000	SWITCH, ANTI-TWO BLOCK
12	1	642918000	CORD CONNECTOR
13	1	366678000	SPRING, EXTENSION
14	1	366201000	WEAR PAD 3 .75 X 2.00 X .313
15	1	366202000	PAD, BOOM TOP
16	1	320988155	BOOM PAD 4.50 X 2.50 X .50, 3203
17	1	320990104	WEAR PAD, 2 X 4 X .25, W/ CSINK HOLES
18	3	407203000	PAD, BOOM, 2.50 O.D. x .563 THK
19	1	239000000	ZERK DRIVE GR
20	2	320990105	SCREW, FLAT HEAD, 5/16-18 UNC X 1, ZP
21	3	016801000	NUT HX NYLK 5/16-18UNC CP
22	1	811029000	SCREW HX HD 5/16-18UNC X 2 1/2 LG
23	1	366393000	SCREW HX HD 5/8-11UNC X 2 1/2 LG GR8
24	1	018200000	NUT HX NYLK 5/8-11UNC
25	4	738733100	SCREW HX HD 3/8-24UNF X 7/8 LG
26	4	020901000	WASHER FL 5/16
27	8	021200000	WASHER FL 3/8
28	4	021100000	WASHER SP LK 3/8

3203PRX BOOM ASSEMBLY

P/N: 320988102



NOTE: APPLY LOCTITE 242 TO BOLT
THREADS. 8 PLC'S BEFORE INSTALLING

CYLINDER SEAL KIT: 320835002
C'BAL CARTRIDGE: 480188000

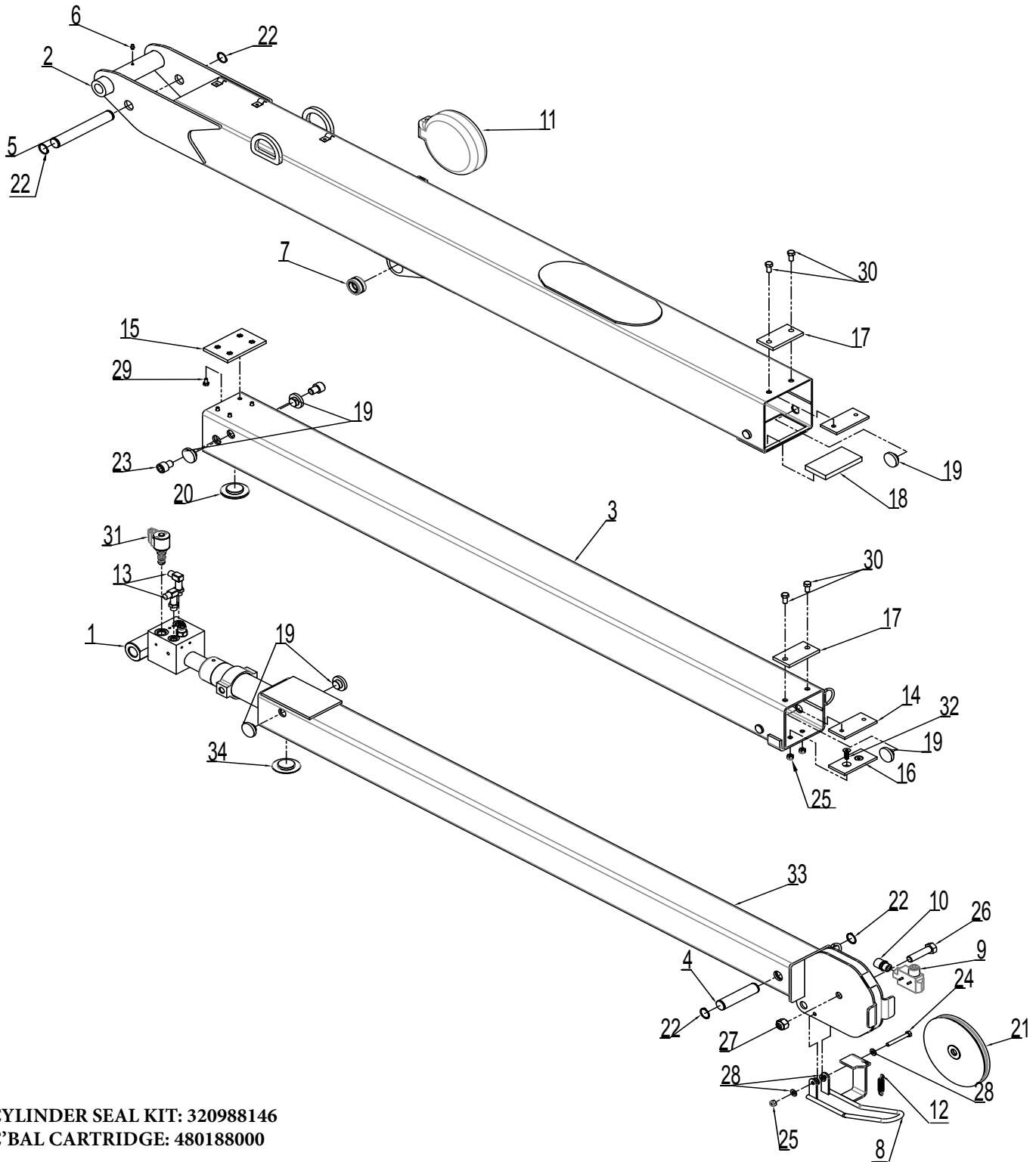
3203PRX BOOM ASSEMBLY

P/N: 320988102

ITEM NO.	QTY	PART NUMBER	DESCRIPTION
1	1	320988110	LOWER BOOM WELDMENT, 3203 PR/PRX
2	1	320988165	MID BOOM WMT, 3203
3	1	320988160	UPPER BOOM WLDMT 3203
4	1	320858000	BEARING, SPHERICAL 1.00 ID
5	1	320883000	SHEAVE ASSEMBLY
6	1	366112000	STOP UPPER BOOM
7	1	366183000	STOP CENTER BOOM
8	1	366190000	PIN ASSY W/LANYARD
9	1	320988142	EXTENSION CYLINDER, 3203
10	2	320888001	RETAINER, EXTENSION CYLINDER
11	1	320988115	PIN 1 DIA X 6.905 LG, 3203
12	2	360122000	RING RETAINING 5100-98
13	2	330645000	FITTING 90 6-SAE/6-JIC LONG
14	11	016801000	NUT HX NYLK 5/16-18UNC CP
15	1	320871000	BAIL WELDMENT
16	1	404205000	CORD REEL ASSY
17	1	646900000	SWITCH, ANTI-TWO BLOCK
18	1	642918000	CORD CONNECTOR
19	1	366678000	SPRING, EXTENSION
20	1	366201000	WEAR PAD 3 .75 X 2.00 X .313
21	1	366202000	PAD, BOOM TOP
22	1	320988155	BOOM PAD 4.50 X 2.50 X .50, 3203
23	1	320990104	WEAR PAD, 2 X 4 X .25, W/ CSINK HOLES
24	3	407203000	PAD, BOOM, 2.50 O.D. x .563 THK
25	1	239000000	ZERK DRVE GR
26	2	320990105	SCREW, FLAT HEAD, 5/16-18 UNC X 1, ZP
27	1	811029	SCREW HX HD 5/16-18UNC X 2 1/2 LG
28	1	366393000	SCREW HX HD 5/8-11UNC X 2 1/2 LG GR8
29	1	018200000	NUT HX NYLK 5/8-11UNC
30	8	007804000	SCREW HX HD 5/16-18UNC X 1 1/4 LG CP
31	4	738733100	SCREW HX HD 3/8-24UNF X 7/8 LG
32	4	020901000	WASHER FL 5/16
33	8	021200000	WASHER FL 3/8
34	4	021100000	WASHER SP LK 3/8

3203PRFX BOOM ASSEMBLY

P/N: 320990100



CYLINDER SEAL KIT: 320988146
 C'BAL CARTRIDGE: 480188000

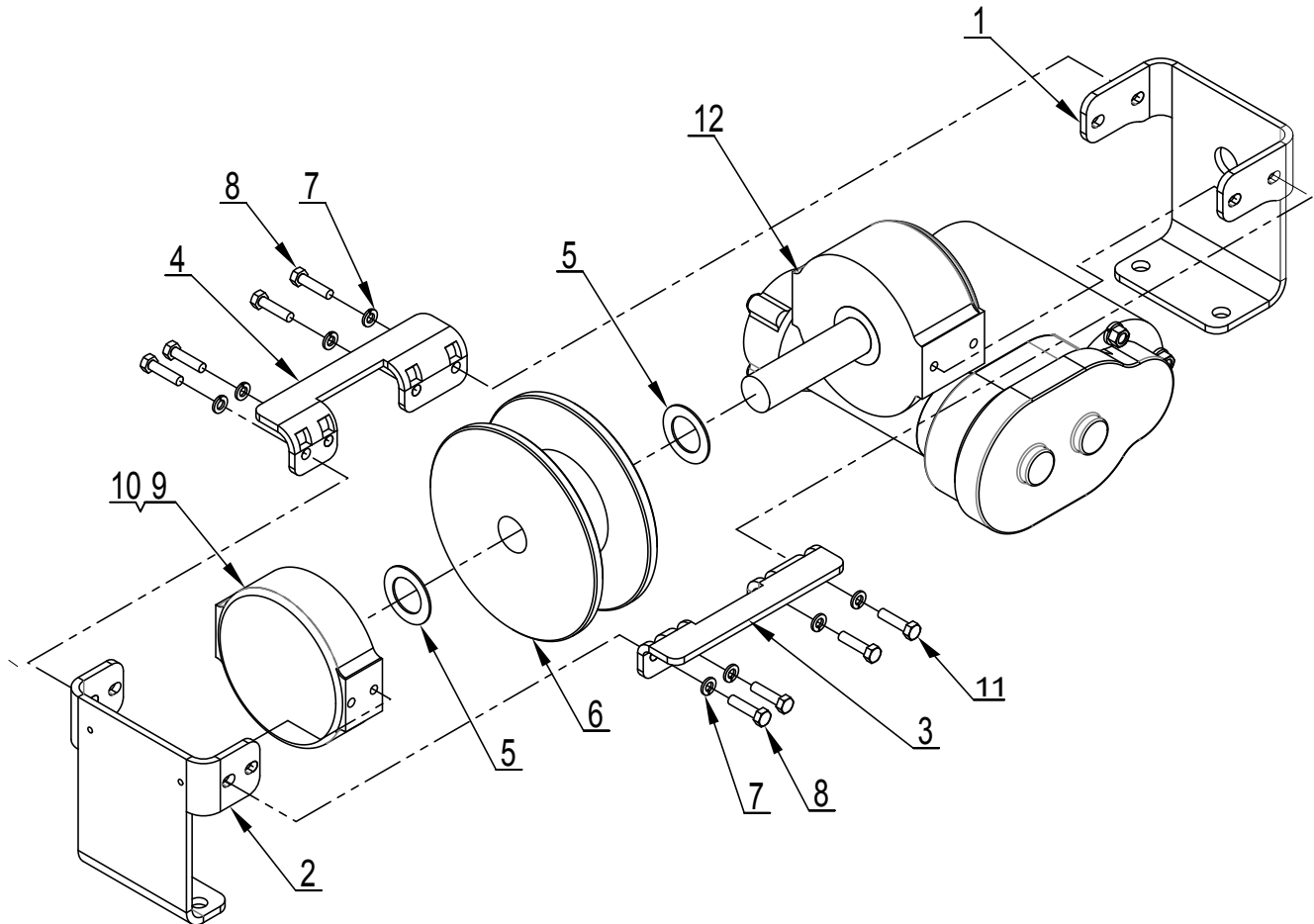
3203PRFX BOOM ASSEMBLY

P/N: 320990100

ITEM NO.	QTY	PART NUMBER	DESCRIPTION
1	1	320988145	CYLINDER, TELESCOPIC, 48" FIRST STAGE, 48" SECOND STAGE, 3-3/8 OD
2	1	320990110	LOWER BOOM WMT 3203 PRFX
3	1	320990120	MID BOOM WMT 3203 PRFX
4	1	738732000	PIN 1n X 4.063 LG
5	1	320988115	PIN 1 DIA X 6.905 LG, 3203
6	1	239000000	ZERK DRIVE GR
7	1	320858000	BEARING, SPHERICAL 1.00 ID
8	1	320871000	BAIL WELDMENT
9	1	646900000	SWITCH, ANTI-TWO BLOCK
10	1	642918000	CORD CONNECTOR
11	1	404205000	CORD REEL ASSY
12	1	366678000	SPRING, EXTENSION
13	2	330645000	FITTING 90 6-SAE/6-JIC LONG
14	2	366483000	PLATE, WEAR PAD .25 X 2 X 4
15	1	320988156	BOOM PAD WITH NUTS, 4.75 X 3 X .313, 3203
16	1	320990104	WEAR PAD, 2 X 4 X .25, W/ CSINK HOLES
17	2	366201000	WEAR PAD 3 .75 X 2.00 X .313
18	1	320988155	BOOM PAD 4.75 X 2.50 X .50, 3203
19	8	360767000	PAD BOOM 1.5 O.D.
20	1	407202000	PAD BOOM 2.50 O.D.
21	1	320883000	SHEAVE ASSEMBLY
22	4	360122000	RING RETAINING 5100-98
23	2	460177162	SCREW SOC HD 5/8-11UNC X 3/4 LG
24	1	811029000	SCREW HX HD 5/16-18UNC X 2 1/2 LG
25	3	016801000	NUT HX NYLK 5/16-18UNC CP
26	1	366393000	SCREW HX HD 5/8-11UNC X 2 1/2 LG GR8
27	1	018200000	NUT HX NYLK 5/8-11UNC
28	4	020901000	WASHER FL 5/16
29	4	005406000	SCREW HX HD 1/4-28UNF X 1/2 LG
30	4	738733000	SCREW HX HD 3/8-24UNF X 3/4 LG
31	1	320990101	VALVE, SPOOL, 3-WAY, W/ COIL & DEUTSCH CONNECTION
32	2	320990105	SCREW, FLAT HEAD, 5/16-18 UNC X 1, ZP
33	1	320990140	UPPER BOOM WMT 3203 PRFX
34	1	470048000	PAD, BOOM 2.50 O.D. X 0.063 THICK

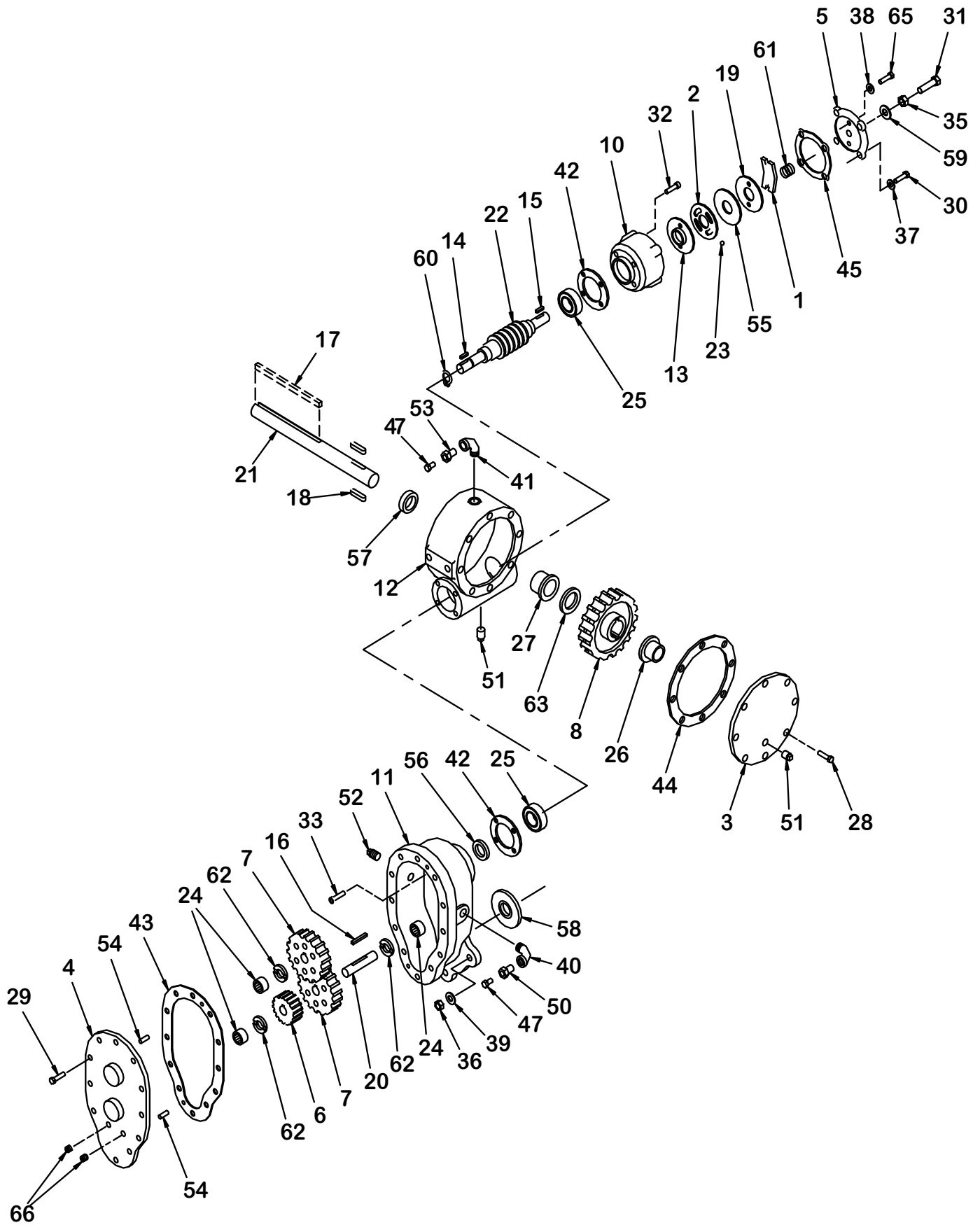
3203PR/PRX HOIST ASSEMBLY

P/N: 110703



ITEM NO.	QTY	PART NO.	DESCRIPTION
1	1	320836	WINCH MOUNTING BRACKET CS
2	1	320837	WINCH MOUNTING BRACKET SS
3	1	320838	WINCH TIE BAR
4	1	320839	WINCH TIE BAR, FRONT
5	2	320887	BEARING, BRONZE
6	1	320379	DRUM
7	8	418163	WASHER SP LK 5/16
8	7	414136	SCREW HX HD 5/16-18UNC X 1 1/4 LG CP
9	1	412003	FLANGE BEARING
10	1	338053	WINCH END BEARING
11	1	414865	CAPSCREW-5/16-18NCX1LG HX SOC HD
12	1	296907	HSG ASSY-SPUR GEAR

3203PR/PRX HOIST ACTUATOR



3203PR/PRX HOIST ACTUATOR

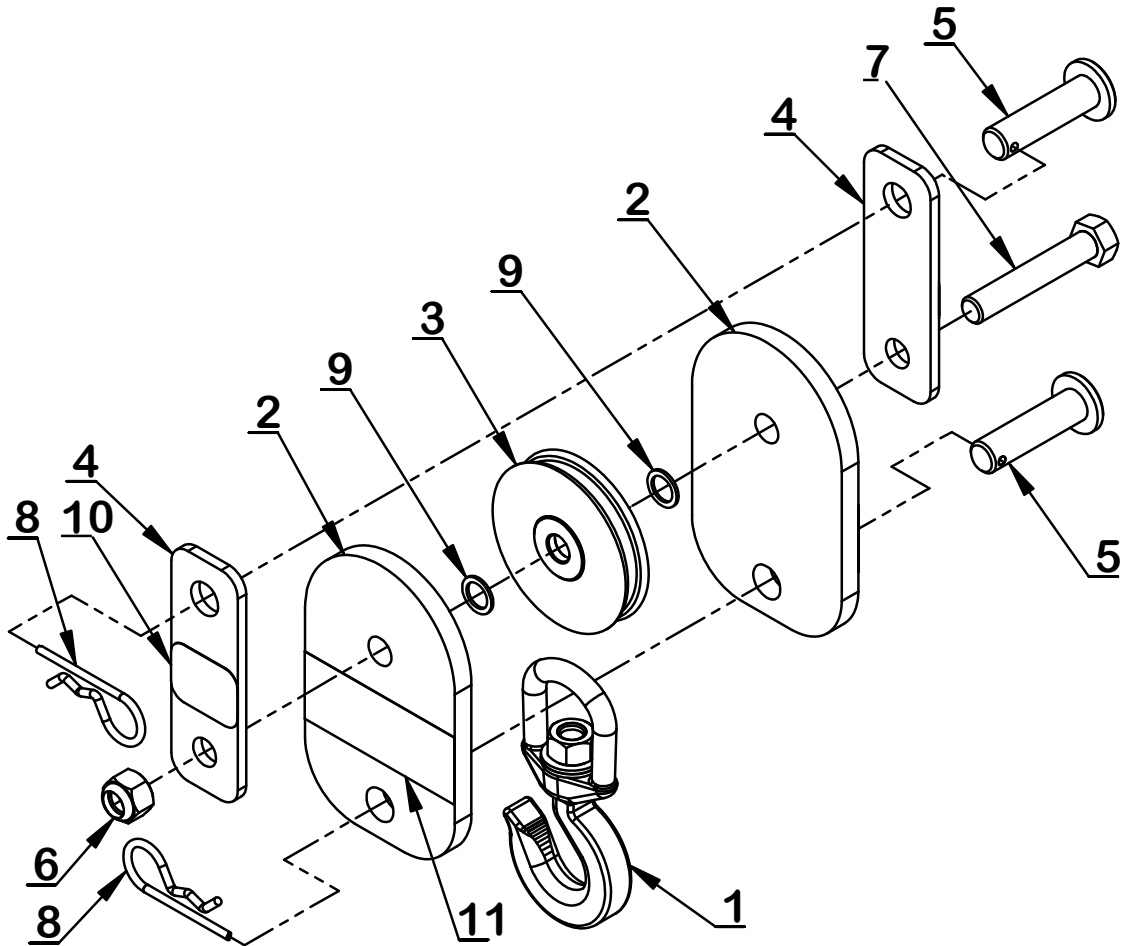
ITEM NO.	QTY.	PART NO.	DESCRIPTION
1	1	306034	SPRING FLAT
2	1	314008	PLATE CAM
3	1	328009	COVER GEAR HOUSING
4	1	328106	COVER WORM GEAR HOUSING
5	1	328128	COVER BRAKE
6	1	334001	IDLER GEAR
7	2	334003	SPUR GEAR
8	1	334007	GEAR WORM RH
9			NOT USED
10	1	338007	HOUSING BRAKE
11	1	338203	SPUR GEAR HOUSING
12	1	338238	GEAR HOUSING
13	1	340002	HUB BRAKE
14	1	342023	KEY 3/16 SQ X 1/2 LG
15	1	342027	KEY 3/16 SQ X 1 LG
16	1	342033	KEY 3/16 SQ X 1 7/16 LG
17	1	342198	KEY 1/4 SQ X 2 1/8 LG
18	2	342075	KEY RD 5/16 X 5/16 X 15/16 LG
19	1	352022	PLATE RETAINER
20	1	356901	SPUR GEAR SHAFT
21	1	357515	OUTPUT SHAFT
22	1	368192	WORM R.H.
23	2	400003	BALL
24	3	402001	BEARING NEEDLE
25	2	402002	BEARING BALL
26	1	412003	BUSHING
27	1	412046	BUSHING
28	8	414020	SCREW HX HD 1/4-20UNC X 3/4 LG NY LK
29	12	414038	SCREW HX HD 1/4-20UNC X 3/4 LG
30	4	414039	SCREW HX HD 1/4-20UNC X 1 LG
31	1	414224	SCREW HX HD 3/8-16UNC X 1 1/2 LG ALL THD
32	4	414821	SCREW BTN HD 1/4-20UNC X 7/8 LG
33	4	414845	SCREW SOC HD 1/4-20UNC X 1 LG
34			NOT USED
35	1	418036	NUT JAM 3/8-16UNC
36	3	418040	NUT HX 3/8-24UNF
37	4	486070	WASHER SP LK 1/4 MED SECT
38	2	418154	WASHER FL 1/4 ALUM
39	3	418177	WASHER SP LK 3/8
40	1	432011	ELL 90 DEG 3/8-18 NPT BOTH ENDS
41	1	432012	ELL 90 DEG 1/4-18 NPT BOTH ENDS
42	2	442184	GASKET BEARING
43	1	442185	GASKET SPUR GEAR HOUSING
44	1	442186	GASKET GEAR HOUSING COVER

3203PR/PRX HOIST ACTUATOR

ITEM NO.	QTY.	PART NO.	DESCRIPTION
44	1	442186	GASKET GEAR HOUSING COVER
45	1	442189	GASKET BRAKE COVER
46			NOT USED
47	2	456008	FITTING RELIEF
48			NOT USED
49			NOT USED
50	1	468002	REDUCER -6NPT/-2NPT
51	2	468010	PLUG PIPE -4NPT SQ HD
52	1	468018	PLUG PIPE -6NPT HX SOC HEADLESS
53	1	468024	REDUCER -4NPT/-2NPT
54	2	470001	PIN DOWELL
55	1	474001	PLATE THRUST
56	1	486009	OIL SEAL 3/4 ID X 1 1/4 OD X 1/4 THK
57	1	486017	OIL SEAL 1 1/4 ID X 1 3/4 OD X 1/4 THK
58	1	486023	OIL SEAL 1 1/2 ID X 2 1/4 OD X 5/16 THK
59			NOT USED
60	1	490003	SNAP RING
61	1	494007	SPRING
62	3	518002	WASHER THRUST
63	1	518015	WASHER THRUST
64	1	518018	WASHER FIBER
65	1	414021	SCREW HX HD 1/4-20UNC X 1 LG NYLK
66	2	468017	PIPE PLUG SOC HD -4NPT

3203 TRAVELING BLOCK ASSEMBLY

P/N: 320433000

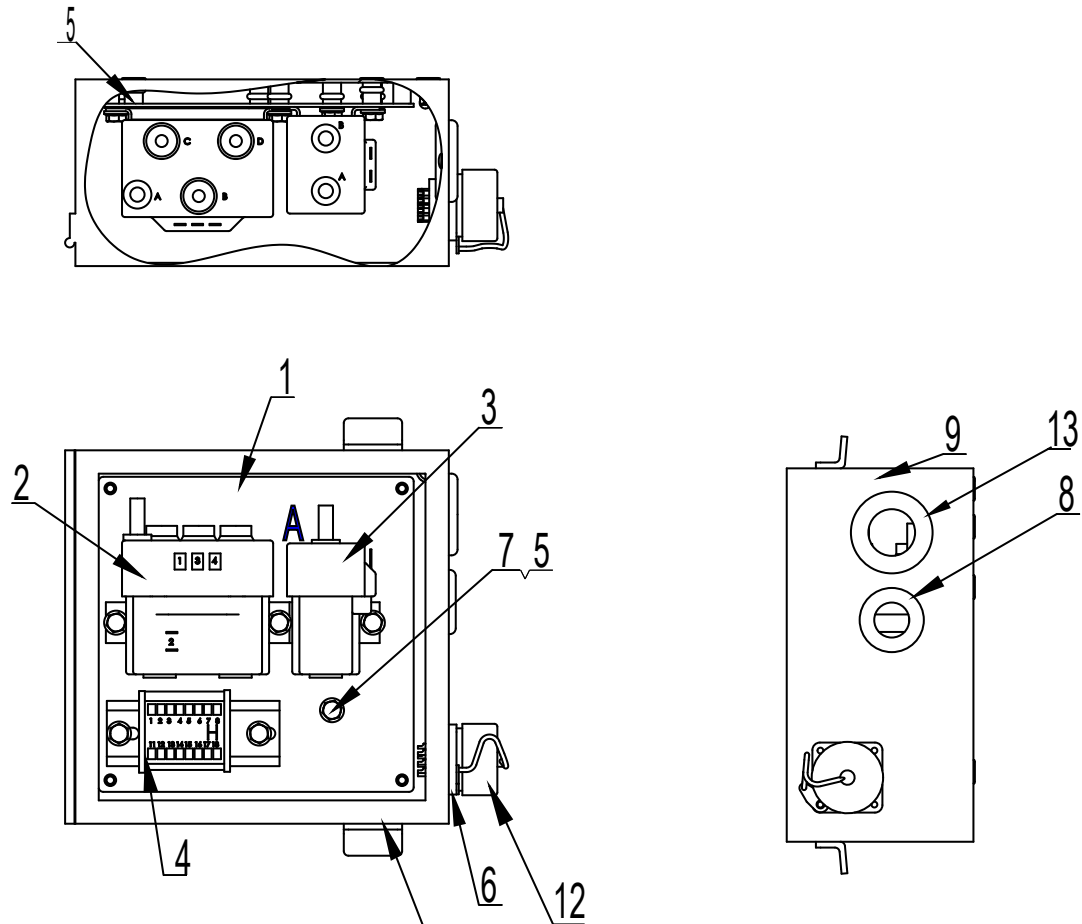


ITEM NO.	QTY	PART NUMBER	DESCRIPTION
1	1	100309000	SWIVEL HOOK ASSY W/LATCH
2	2	320403000	SIDE PLATE, 3203
3	1	200909000	SHEAVE ASSEMBLY
4	2	320404000	BLOCK TRAVELING
5	2	320434001	PIN, 3/4 X 2-3/4 LG
6	1	018200000	NUT HX NY LK 5/8-11UNC
7	1	013512000	SCREW HX HD 5/8-11UNC X 3 1/2 LG
8	2	366813000	PIN HITCH
9	2	330100000	WASHER, FL 5/8 X 7/8 OD
10	2	320433100	DECAL, TRAVELING BLOCK 3203
11	2	040518000	DECAL STAY CLEAR OF LOAD

NOTES

3203PR/PRX RELAY PANEL ASSEMBLY

P/N: 320988300

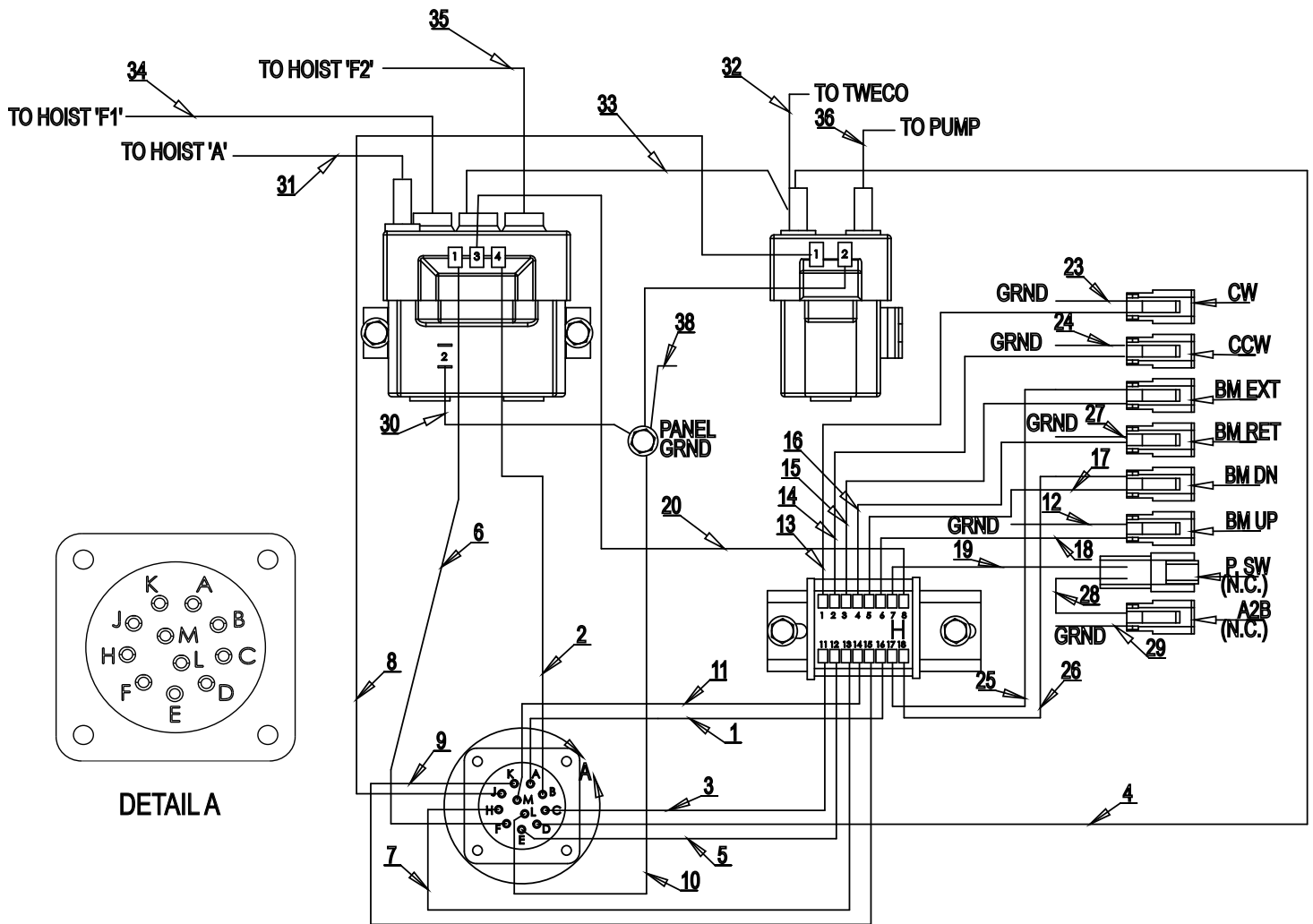


REF FOR REPLACEMENT PART ONLY
(680178000) RECEPTACLE W/WIRE PIGTAIL

ITEM NO.	QTY	PART NO.	DESCRIPTION
1	1	320988256	BULKHEAD ELECTRICAL PLATE
2	1	320589000	RELAY, HOIST
3	1	320584000	RELAY, POWER UNIT
4	1	320988399	TERMINAL STRIP 8
5	10	736272000	NUTSERT 1/4-20UNC X .027-.165 GRIP
6	1	320562000	RECEPTACLE, 11 PIN, 1/4 TURN, BAYONET
7	6	360493000	SCREW HX WHIZ-LK 1/4-20UNC X 1/2 LG
8	1	371024000	GROMMET 3/4" I.D.
9	1	320988255	ELECTRICAL BOX, 8X8X4
10	7	366367000	DEUTSCH 2 PIN Assembly
11	1	360769001	HOUSING, DEUTSCH 2-PIN RECEPTACLE
12	1	320564000	CAP WITH CHAIN (FOR RECEPTACLE)
13	1	750282000	GROMMET, RUBBER, 1.375 OD, 1.00 ID

3203PR/PRX ELECTRICAL SCHEMATIC

P/N: 320988300



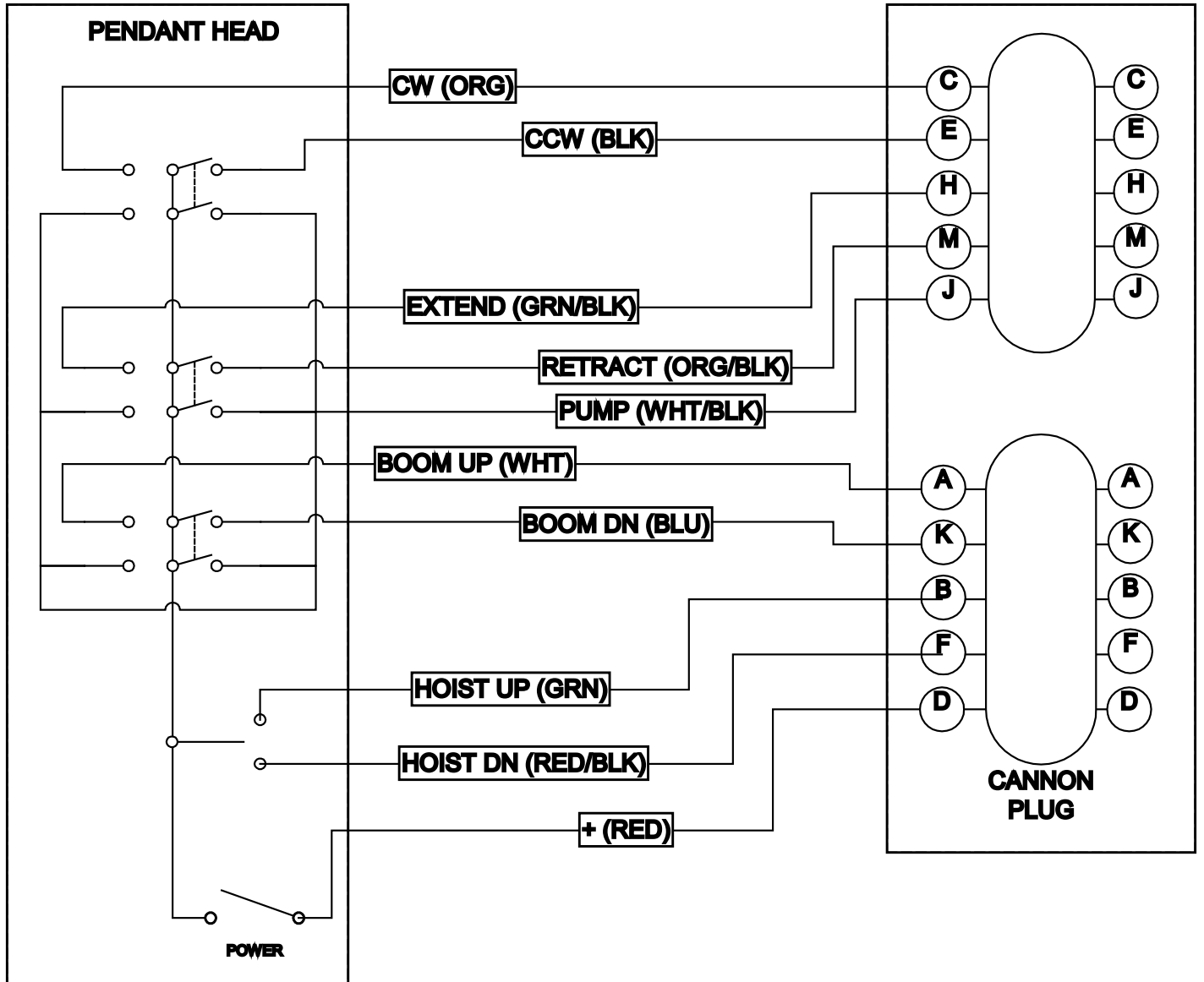
3203PR/PRX ELECTRICAL SCHEMATIC

P/N: 320988300

ITEM NO.	PART NO.	COLOR	GAGE
1	REF	YELLOW	16
2	REF	GREEN	16
3	REF	ORANGE	16
4	REF	RED	16
5	REF	WHITE/RED	16
6	REF	RED/BLACK	16
7	REF	GREEN/BLACK	16
8	REF	WHITE/BLACK	16
9	REF	BLUE	16
10	REF	BLACK	16
11	REF	ORANGE/BLACK	16
12	REF	WHITE	16
13	REF	ORANGE	16
14	REF	WHITE/RED	16
15	REF	GREEN/BLACK	16
16	REF	ORANGE/BLACK	16
17	REF	BLUE	16
18	REF	YELLOW	16
19	REF	RED	16
20	REF	GREEN/WHITE	16
21		NOT USED	
22		NOT USED	
23	REF	WHITE	16
24	REF	WHITE	16
25	REF	RED/WHITE	16
26	REF	BLUE/WHITE	16
27	REF	WHITE	16
28	REF	WHITE/RED	16
29	REF	WHITE	16
30	REF	WHITE	16
31	320988331	BLACK	6
32	320988332	BLACK	6
33	320988333	BLACK	6
34	320988334	BLACK	6
35	320988335	BLACK	6
36	320988336	BLACK	6
37	REF	WHITE	16
38	320988338	BLACK	16

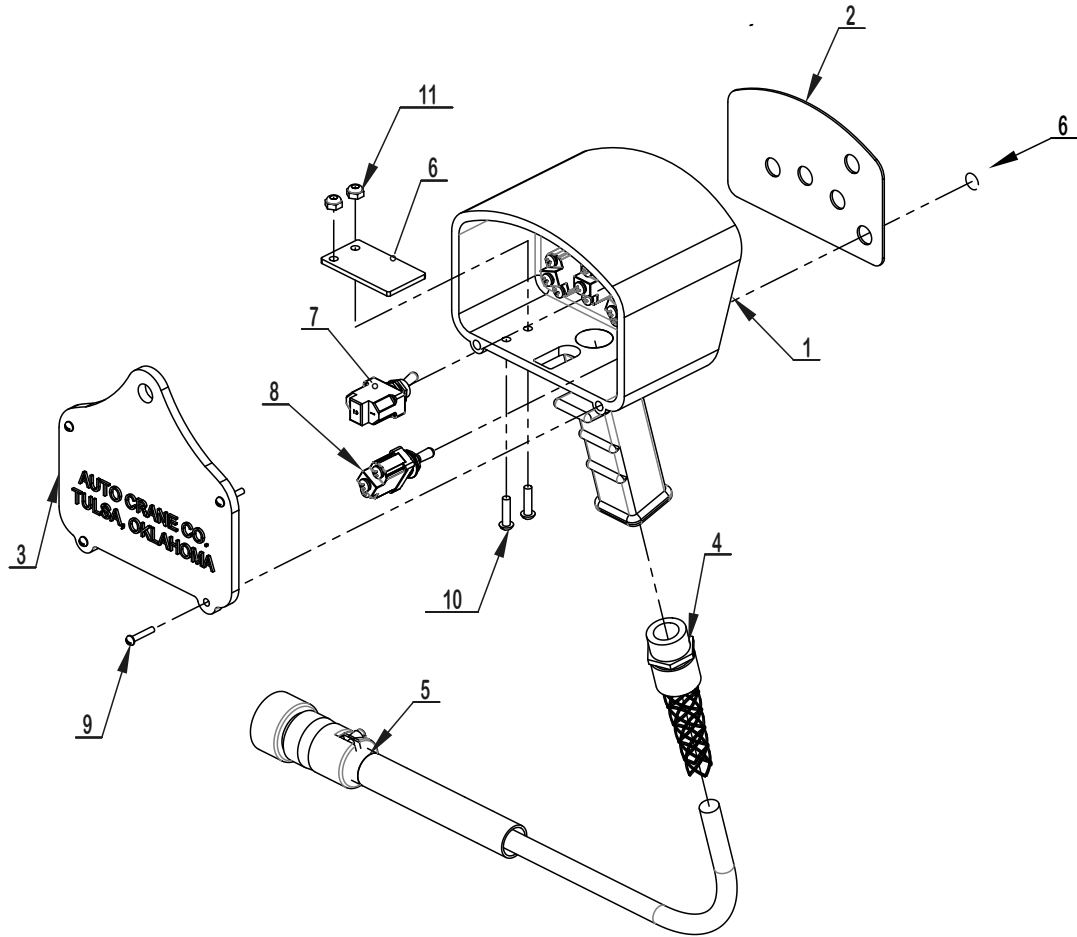
3203PR/PRX PENDANT ASSEMBLY

P/N: 680179000



3203PR/PRX PENDANT ASSEMBLY

P/N: 680179000

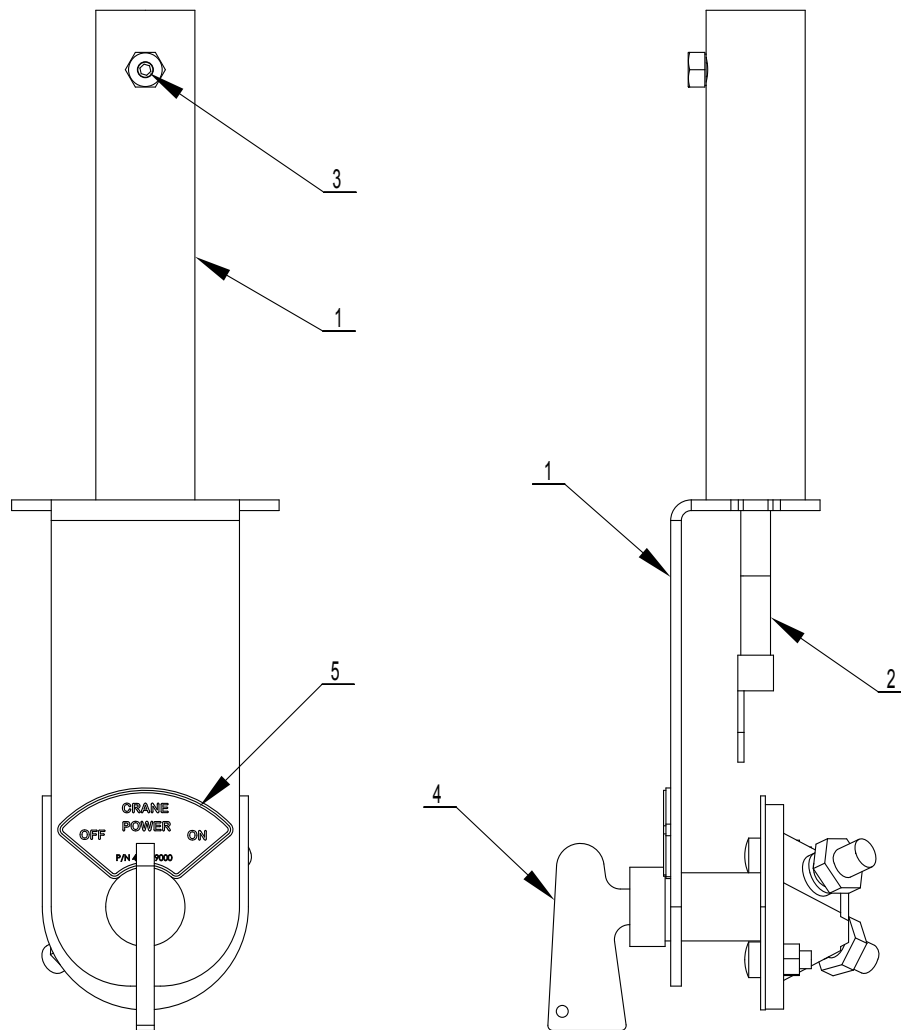


ITEM NO.	QTY.	PART NO.	DESCRIPTION
1	1	480501000	PENDANT HOUSING
2	1	366719000	DECAL, PENDANT 8 FUNC W/PWR
3	1	480504000	PENDANT BACK PLATE
4	1	600820000	CORD GRIP, 3/4 NPT, .50-.625" CORD
5	1	680179001	PENDANT CABLE, 11 PIN BAYONET
6	1	480598000	COVER TRIGGER OPENING
7	1	750090000	TOGGLE SWITCH, 1 POLE, 2 POSITION
8	4	634200000	TOGGLE SWITCH KIT
9	4	001004000	SCREW PN HD #6 X 3/4 LG
10	2	002607000	SCREW RD HD #10-24UNC X 3/4 LG CP
11	2	015801000	NUT HX NYLK #10-24UNC ZP

NOTES

3203PR/PRX TWECO W/SWITCH MOUNT

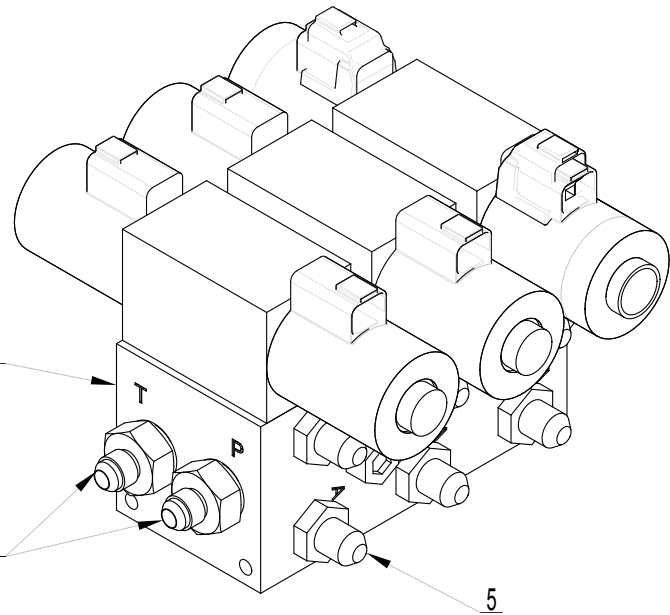
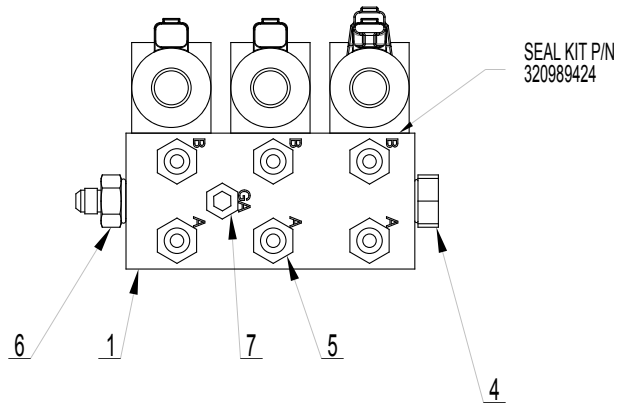
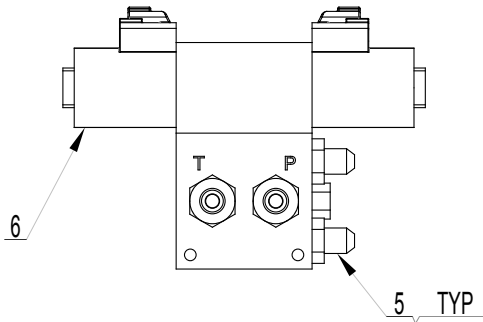
P/N: 404218000



ITEM NO.	QTY	PART NO.	DESCRIPTION
1	1	404217000	LOWER TWECO WELD WITH SWITCH MOUNT
2	1	404224000	CABLE ASSY 11 IN, TWECO TO TERMINAL
3	1	002900000	SCREW SET 1/4-20UNC X 1/4 LG
4	1	404216000	MASTER SWITCH
5	1	404219000	DECAL, CRANE POWER

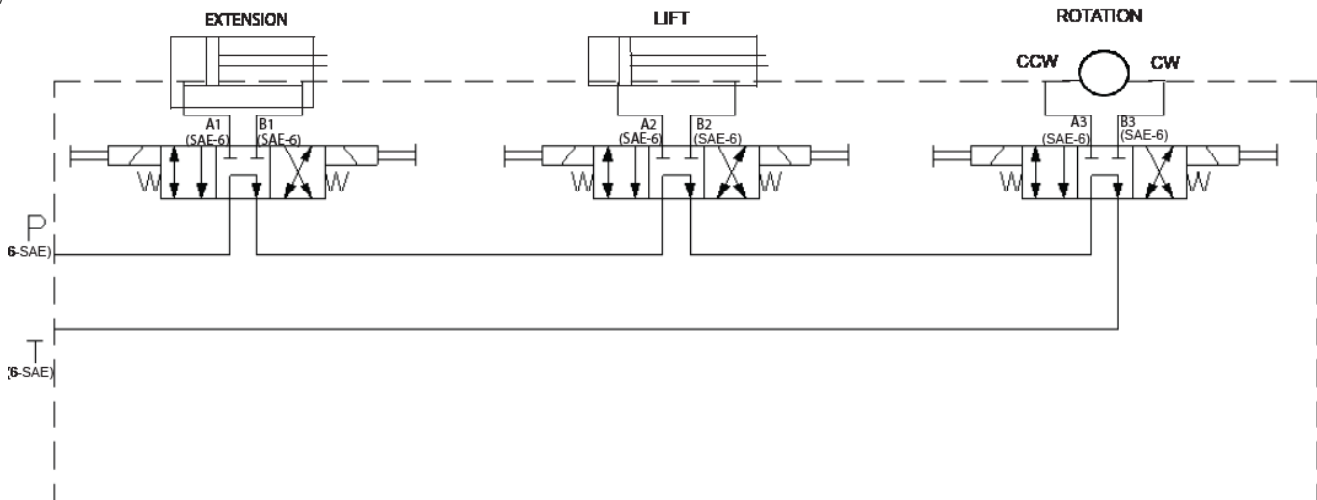
3203PR/PRX HYDRAULIC CONTROL VALVE

P/N: 320989420

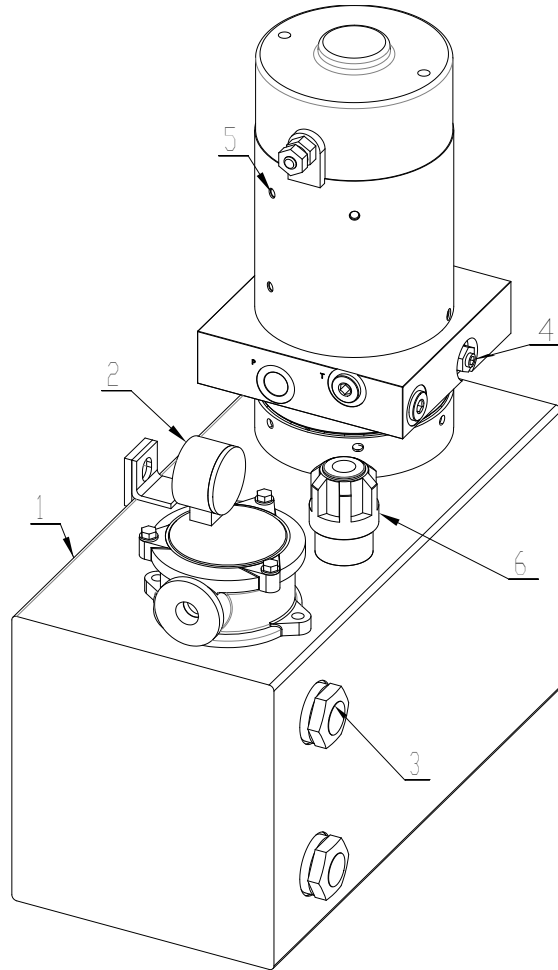


ITEM NO.	HYTOS QTY.	PARKER QTY.	PART NUMBER	DESCRIPTION
1	1	1	320989421	MANIFOLD BLOCK, DO3
2	3	-	320989428	VALVE, DO3 STACK TYPE, HYTOS
	-	3	320989422	VALVE, DO3 STACK TYPE, PARKER
3	6	-	320989429	COIL, 12V-2.7A HYTOS, FOR 320989420
	-	6	320989423	COIL, 12V-2.5A PARKER, FOR 320989420
4	2	2	330072000	PLUG, #10 SAE
5	6	6	202756000	FITTING 6-8 STRAIGHT
6	2	2	202755000	FITTING, -10 SAE/-6 JIC, STR
7	1	1	751034000	PLUG, -6ORB

REPLACEMENT COILS:
 (BLACK) = 320989423
 (STEEL) = 320989429



3203 POWER UNIT P/N 320991279

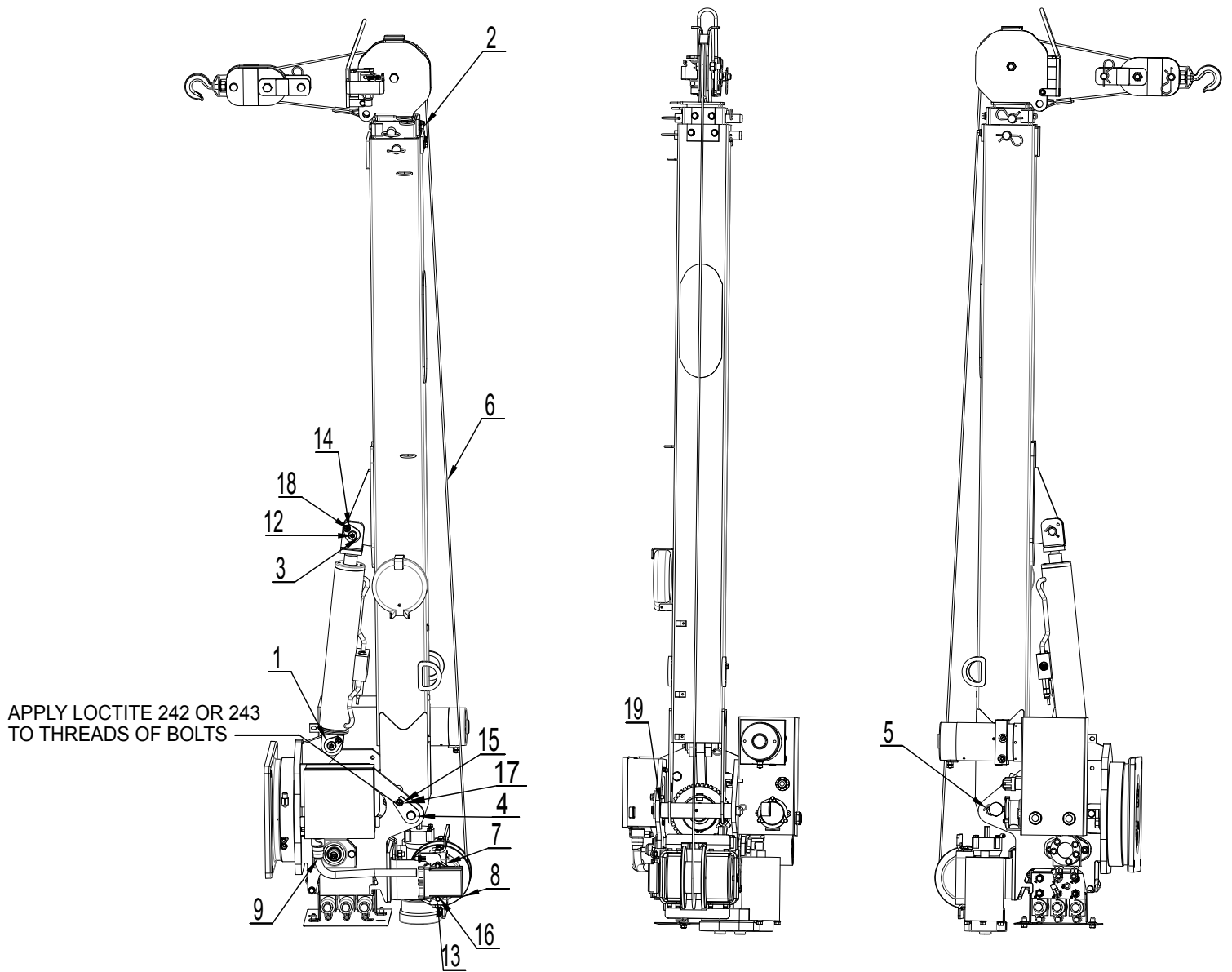


ITEM NO.	QTY	PART NUMBER	DESCRIPTION
1	1	320991272	TANK, NEXSTAR 3203/4004EH
2	1	320991908	GAUGE, FILTER USED W/320991270
3	2	320991274	GLASS, SIGHT USED W/320991270
4	1	320991284	BASE ASSEMBLY USED W/320991270
5	1	320991271	MOTOR, NEXSTAR 3203/4004EH
6	1	320991275	CAP, FILLER USED W/ 320991270
7*	1	320991277	VALVE, RELIEF USED W/320991270
8*	1	320991910	FILTER, ELEMENT SMALL EH NEXSTAR
9*	1	320991285	O-RING USED W/ 320991270
10*	1	320991286	PUMP, 3203/4004EH

* NOT SHOWN

3203PR GENERAL ASSEMBLY

FM - P/N: 320989005



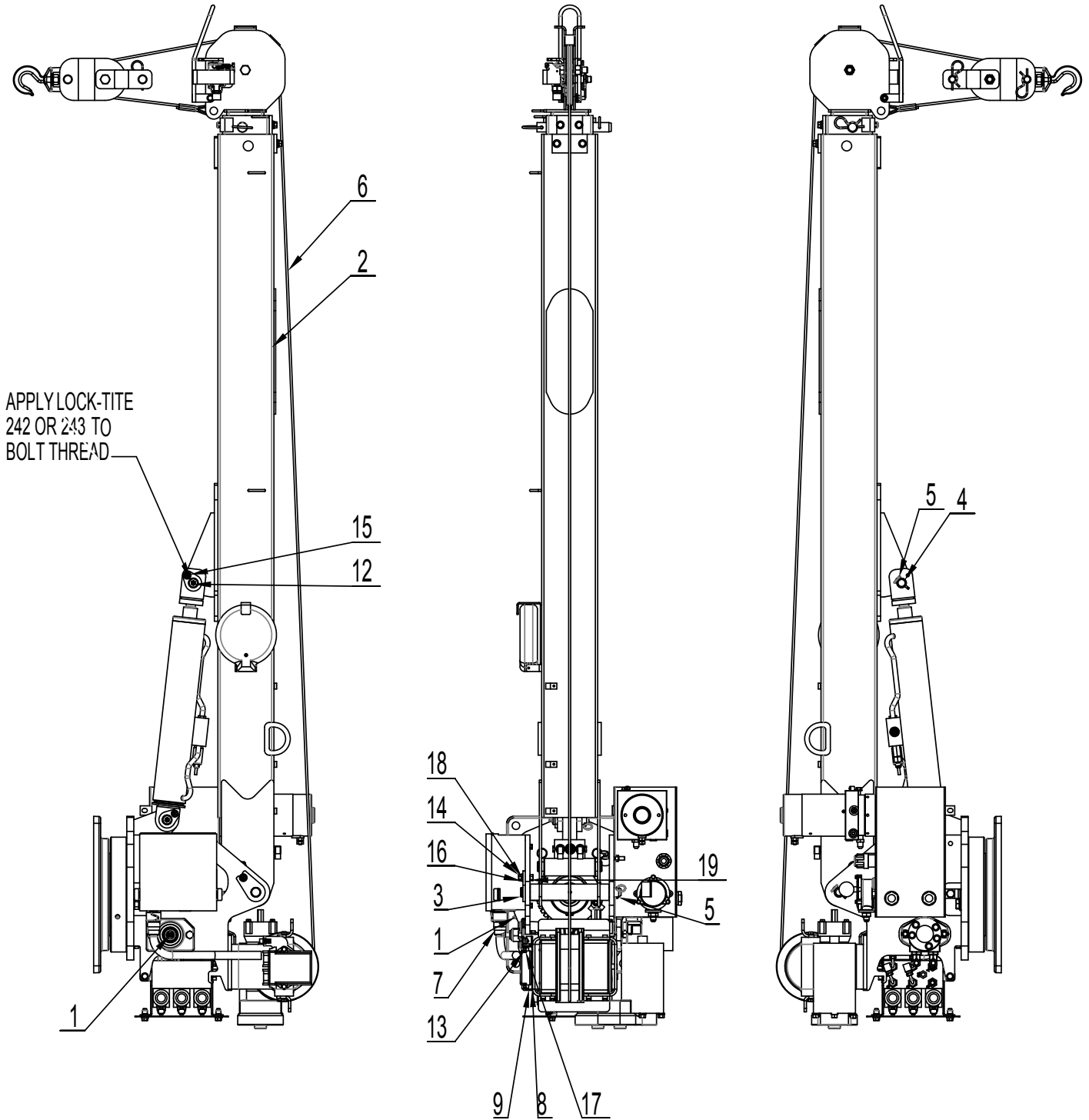
3203PR GENERAL ASSEMBLY

FM - P/N: 320989005

ITEM NO.	QTY	PART NUMBER	DESCRIPTION
1	1	320988204	PEDESTAL ASSEMBLY, 3203 PR
2	1	320988103	BOOM ASSY 3203 PR
3	1	320824000	PIN, LIFT CYLINDER
4	1	404220000	PIN WDMT BOOM/PED
5	2	360678000	PIN, 3/16 COTTERLESS RING
6	1	320338002	CABLE ASS'Y, 7/32" x 62FT, THIMBLE END
7	1	361102001	MOUNTING BRACKET, OMNEX PENDANT PLUG
8	1	460158000	RECEIVER, NON-PROPORTIONAL,
9	1	680180000	HARNESS, FM, 3203PR(X)
10*	1	320988013	SHIP KIT, 3203 PR/PRX, FM
11*	1	320988004	DECAL LAYOUT, 3203
12	1	239300000	ZERK, GREASE
13	2	005604000	SCREW HX HD 1/4-20UNC X 1 LG
14	1	330371000	SCREW HX HD 3/8-16UNC X 1 LG GR8
15	1	366159000	SCREW HX HD 3/8-16UNC X 1 1/2 LG GR8
16	2	020200000	WASHER SP LK 1/4
17	2	021200000	WASHER FL 3/8
18	2	021100000	WASHER SP LK 3/8
19	1	330372000	NUT HX 3/8-16UNC
* NOT SHOWN			

3203PRX GENERAL ASSEMBLY

FM - P/N: 320989004



3203PRX GENERAL ASSEMBLY

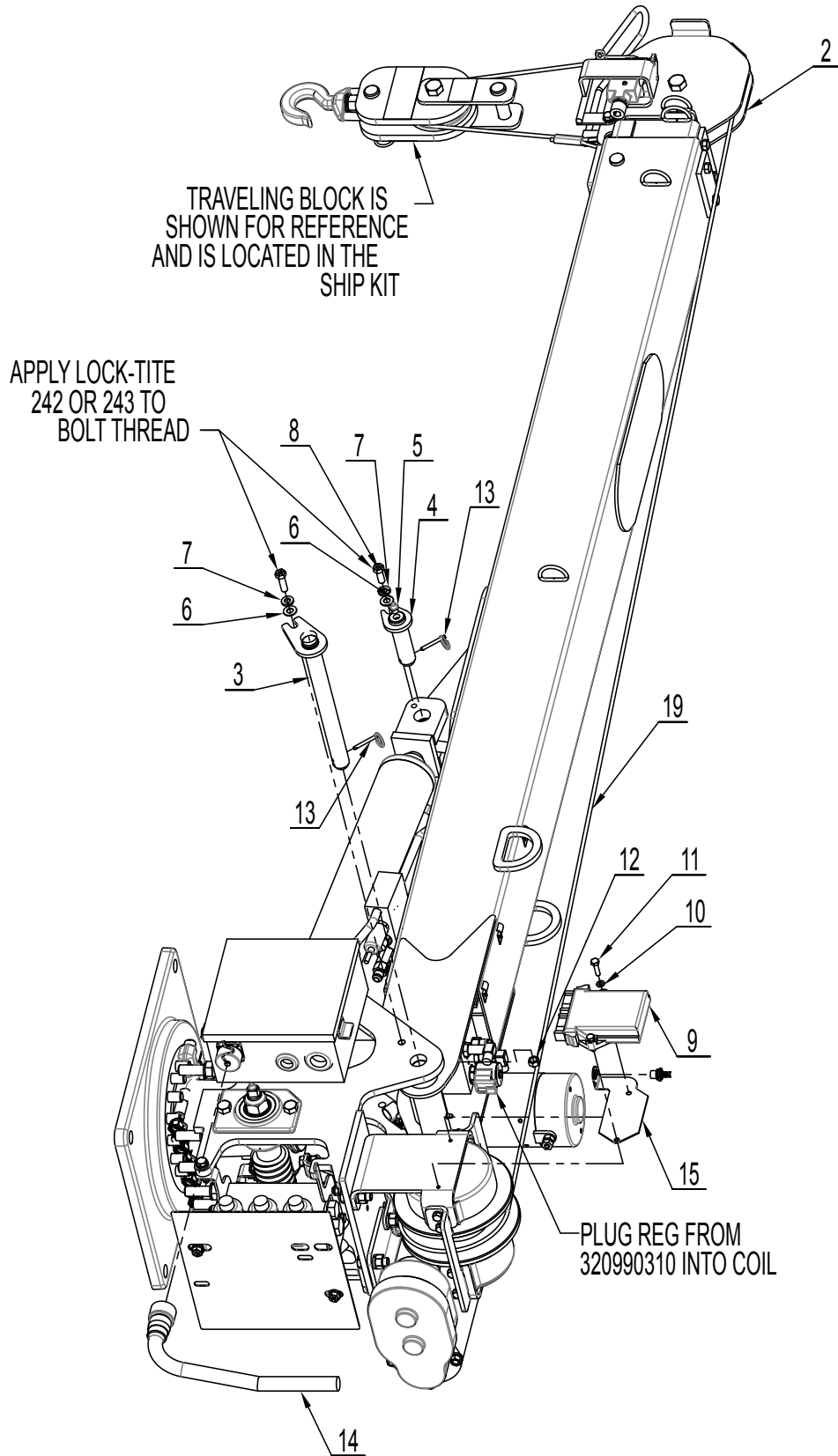
FM - P/N: 320989004

ITEM NO.	QTY	PART NO.	DESCRIPTION
1	1	320988203	PEDESTAL ASSEMBLY, 3203 PRX
2	1	320988102	BOOM ASSY 3203 PRX
3	1	404220000	PIN WDMT BOOM/PED
4	1	320824000	PIN, LIFT CYLINDER
5	2	360678000	PIN, 3/16 COTTERLESS RING
6	1	320338002	CABLE ASS'Y, 7/32" x 62FT, THIMBLE END
7	1	680180000	HARNESS, FM, 3203PR(X)
8	1	361102001	MOUNTING BRACKET, OMNEX PENDANT PLUG
9	1	460158000	RECEIVER, NON-PROPORTIONAL,
10*	1	320988004	DECAL LAYOUT, 3203
11*	1	320988013	SHIP KIT, 3203 PR/PRX, FM
12	1	000239300	ZERK, GREASE
13	2	005604000	SCREW HX HD 1/4-20UNC X 1 LG
14	1	366159000	SCREW HX HD 3/8-16UNC X 1 1/2 LG
15	1	330371000	SCREW HX HD 3/8-16UNC X 1 LG
16	2	021100000	WASHER SP LK 3/8
17	2	020200000	WASHER SP LK 1/4
18	2	021200000	WASHER FL 3/8
19	1	330372000	NUT HX 3/8-16UNC

*NOT SHOWN

3203PRFX GENERAL ASSEMBLY

FM - P/N: 320990000



3203PRFX GENERAL ASSEMBLY

FM - P/N: 320990000

ITEM NO.	QTY	PART NUMBER	DESCRIPTION
1	1	320990200	PEDESTAL ASSEMBLY, 3203 PRFX
2	1	320990100	BOOM ASSY 3203PRFX
3	1	404220000	PIN WDMT BOOM/PED
4	1	320824000	PIN, LIFT CYLINDER
5	1	239300000	ZERK, GREASE
6	2	021200000	WASHER FL 3/8
7	2	021100000	WASHER SP LK 3/8
8	1	330371000	SCREW HX HD 3/8-16UNC X 1 LG GR8
9	1	460158000	RECEIVER, NON-PROPORTIONAL,
10	2	020200000	WASHER SP LK 1/4
11	2	005604000	SCREW HX HD 1/4-20UNC X 1 LG
12	1	330372000	NUT HX 3/8-16UNC
13	2	360678000	PIN, 3/16 COTTERLESS RING
14	1	680180000	HARNESS, FM, 3203PR(X)
15	1	361102001	MOUNTING BRACKET, OMNEX PENDANT PLUG
16	1	320988013	SHIP KIT, 3203 PR/PRX, FM
17	1	320988004	DECAL LAYOUT, 3203
18	1	366159000	SCREW HX HD 3/8-16UNC X 1 1/2 LG GR8
19	1	320338002	CABLE ASS'Y, 7/32" x 62FT, THIMBLE END

FM CONTROL USE AND CARE

TRANSMITTER LAYOUT

There is a red light to the left of the *ON/OFF Toggle switch* and a yellow light to the right. As the battery runs down, the red light will begin to flash as well as the yellow light.

If the yellow light is rapidly flashing this indicates that the unit is transmitting. Refer to the Transmitter Diagnostics Section for a detailed explanation of each light combination.

In addition to the two lights mentioned above there are four function toggle switches. These functions from left to right are to be used to raise and lower the boom, raise and lower the hoist cable, rotate the crane and extend and retract the boom.



POWER ON/OFF TOGGLE SWITCH

The transmitter is powered by 4-AA alkaline batteries, located under the back cover of the housing. To turn the transmitter on, press and hold the *Power On Toggle*, release once the transmit light starts blinking. To turn the unit off, press and hold the power off toggle, release after the transmit light stops flashing.

FUNCTION SWITCHES

To operate a function, toggle one of the function switches with either the thumb of the hand holding the unit or the thumb or fingers of the opposite hand. More than one function can be activated at one time.

CARE

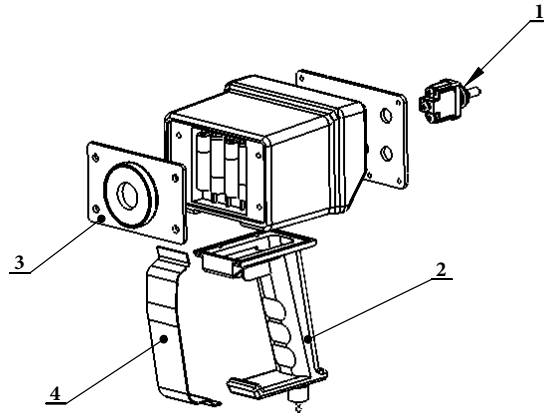
KEEP DRY. Do not clean the transmitter / receiver under high pressure. If water or other liquids get inside the transmitter battery or receiver compartment, immediately dry the unit. Remove the case and let the unit air dry.

WELDING

DISCONNECT THE RADIO RECEIVER BEFORE WELDING on the crane, load, or truck. Failure to disconnect will result in the destruction of the radio receiver.

TRANSMITTER - P/N: 460157000

FM CONTROL

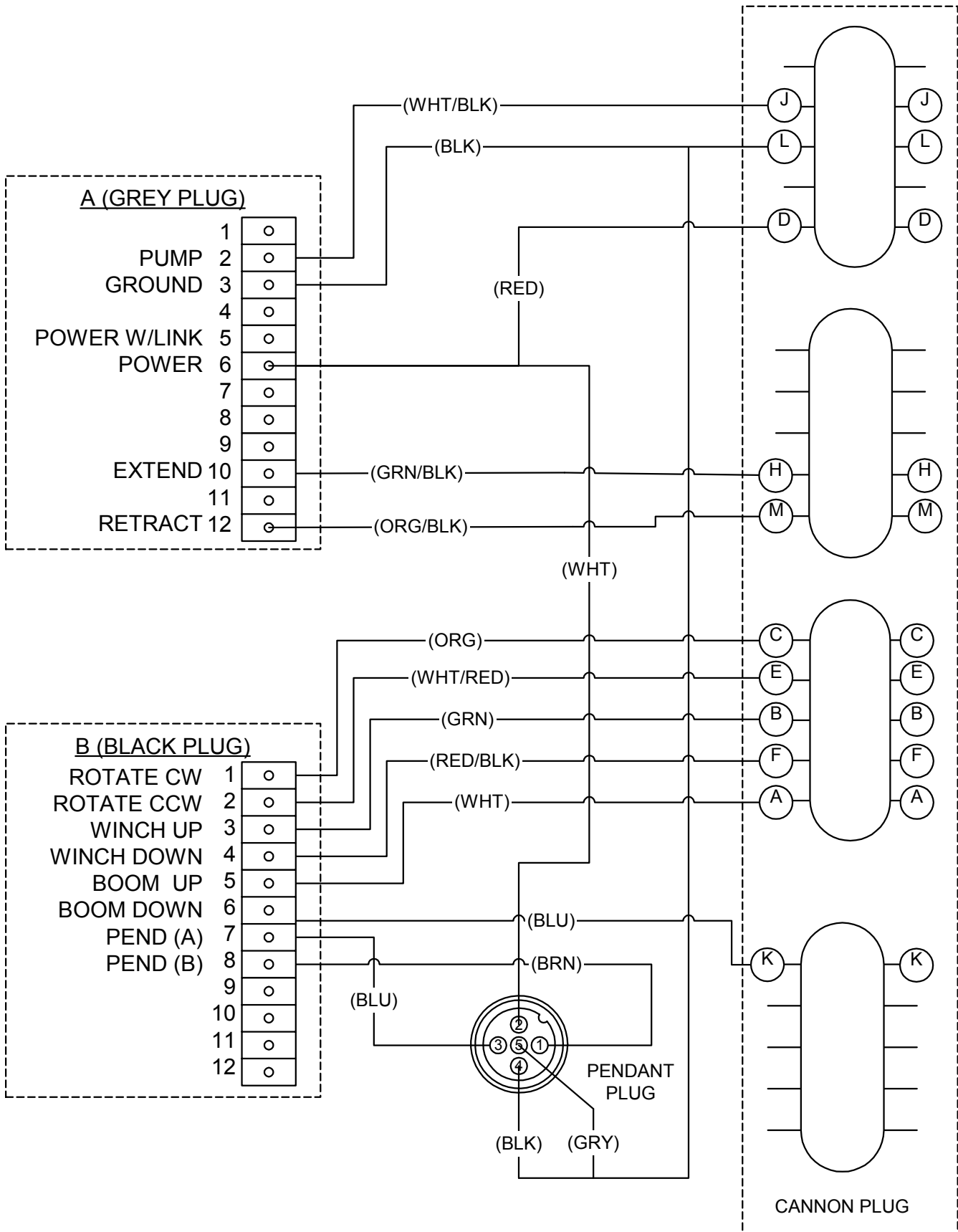


ITEM NO.	QTY.	PART NO.	DESCRIPTION
1	5	460166000	TOGGLE SWITCH KIT (OMNEX)
2	1	460168000	HANDLE, TRANSMITTER W/O TRIGGER
3	1	460163000	COVER, TRANSMITTER BATTERY W/MAGNET
4	1	460162000	GUARD, TRIGGER (OMNEX)

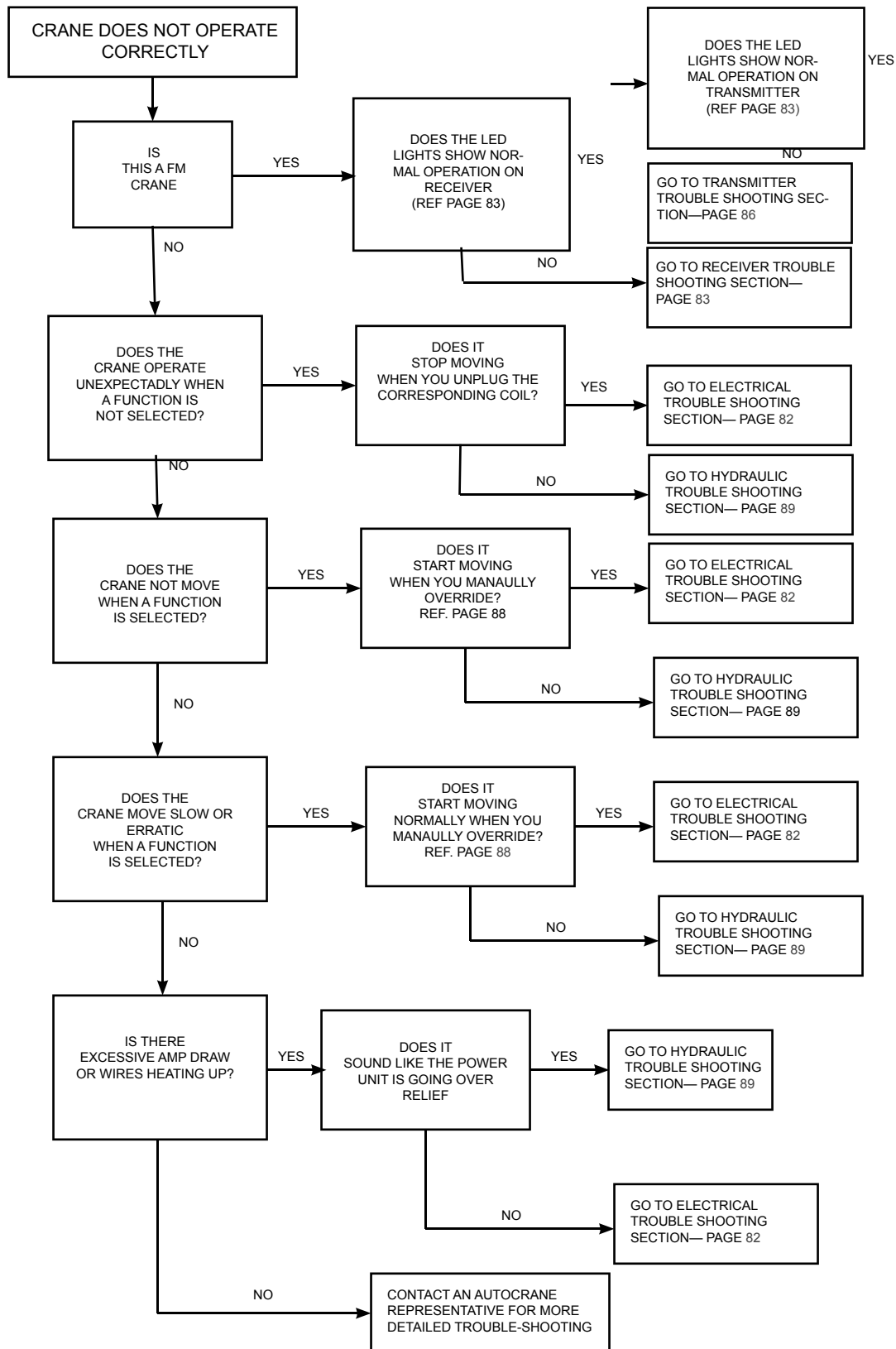
TOGGLE SWITCH WIRING CHART		
FUNCTION	WIRE COLOR	TERMINAL POSITION
POWER ON	YELLOW	BOTTOM
POWER OFF	GREEN (FROM 8 PIN CONNECTOR)	TOP
BOOM UP	RED	BOTTOM
BOOM DN	ORANGE	TOP
BOOM EXTEND	GREEN (FROM 10 PIN CONNECTOR)	BOTTOM
BOOM RETRACT	BLUE	TOP
ROTATE CW	VIOLET	BOTTOM
ROTATE CCW	GREY	TOP
HOIST UP	WHITE	BOTTOM
HOIST DN	BROWN	TOP
COMMON	BLACK	MIDDLE

3203PR/PRX ELECTRICAL SCHEMATIC

P/N: 680180000



3203EH TROUBLESHOOTING CHART



3203EH

ELECTRICAL TROUBLESHOOTING CHART

PROBLEM	POSSIBLE CAUSE	DIAGNOSIS	SOLUTION
CRANE OPERATES UNEXPECTEDLY	DAMAGED TOGGLE SWITCH	TURN OFF OR UNPLUG PENDANT. SEE IF MOVEMENT STOPS	VERIFY THAT NOTHING WAS ACTIVATING TOGGLE SWITCH AT TIME OF MOVEMENT. IF NOT ACTIVATED THEN REPLACE SWITCH
	SHORT IN HARNESS	UNEXPECTED MOVEMENT WOULD ONLY OCCUR WHEN MULTI-FUNCTIONING FOR HYDRAULIC FUNCTIONS. UNPLUG COIL TO SEE IF MOVEMENT STOPS. CHECK FOR VOLTAGE AT THE COIL CONTACTS.	TRACE WIRE BACK TO 1/4 TURN BAYONET PLUG. VERIFY NO DAMAGE TO THE WIRE. CHECK CONNECTORS, THEY SHOULD BE CLEAR OF DEBRIS AND WATER.
	HOIST FUNCTION ALWAYS RUNNING (HOIST UP OR DOWN)	WITHOUT HOIST BEING SELECTED, THE HOIST FUNCTION IS OPERATIONAL	CHECK HOIST RELAY CHECK WIRING FOR A SHORT
	POWER UNIT ALWAYS ACTIVE	IF NO FUNCTION IS SELECTED BUT THE POWER UNIT IS RUNNING ON WHEN NO FUNCTION IS SELECTED	CHECK POWER UNIT RELAY CHECK WIRING FOR SHORT GOING TO POWER UNIT
NO FUNCTION OPERATES ON THE CRANE.	PENDANT TURNED OFF	VERIFY TOGGLE SWITCH ON PENDANT IS IN THE "ON POSITION" - HW UNITS VERIFY YELLOW LIGHT IS FLASHING—FM UNITS	TURN ON TRANSMITTER BY TOGGING THE POWER SWITCH INTO THE "ON" POSITION.
	TRANSMITTER/ RECEIVER NOT SYNCHRONIZED (FM UNITS ONLY)	CHECK LED LIGHTS WITH TRANSMITTER TURNED ON. LINK LIGHT & STATUS LIGHT SHOULD BE GREEN	SYNCHRONIZE TRANSMITTER—REFERENCE ID CODE PROGRAMMING SECTION IN MANUAL
	CRANE TURNED OFF	CHECK MAIN DISCONNECT SWITCH LOCATED IN CRANE BOX AND VERIFY IT IS IN THE ON POSITION.	TURN SWITCH INTO THE "ON" POSITION
	LOW TRANSMITTER BATTERY (FM UNITS ONLY)	WHILE THE TRANSMITTER IS TURNED ON, CHECK THE YELLOW LED ON TRANSMITTER SHOULD BE FLASHING SLOWLY. RED FLASHING IS LOW BATTERY	REPLACE TRANSMITTER BATTERIES. IT REQUIRES (4) AA BATTERIES
	LOST GROUND	USING A VOLTMETER CHECK MAIN POWER WIRE AT RELAY PANEL USING GROUND ON CRANE. THEN CHECK TO SEE IF SAME VOLTAGE FROM CHASSIS GROUND & RELAY PANEL POWER.	USING OHMMETER CHECK RESISTANCE ACROSS ALL COMPONENTS IN THE GROUND CIRCUIT. PAY SPECIAL ATTENTION TO GROUND CONTACTING WORM GEAR. REPLACE OR REMOVE IMPEDENCE FROM CIRCUIT.
	LOW TRUCK BATTERY VOLTAGE	WHEN RUNNING A FUNCTION, CHECK VOLTAGE AT HOIST OR HYDRAULIC POWER UNIT. SHOULD NOT DROP BELOW 10V.	VERIFY TRUCK IS RUNNING WHILE OPERATING CRANE CHECK VEHICLE BATTERY FLUID LEVEL CHECK FOR ADEQUATE WIRE SIZING FOR LENGTH AND AMPERAGE REQUIREMENTS
	POWER UNIT NOT ACTIVATING	IF RECEIVER HAS POWER BUT THE POWER UNIT DOESN'T TURN ON WHEN A FUNCTION IS SELECTED	CHECK POWER UNIT RELAY CHECK GROUNDING WIRE FROM RELAY TO PUMP CHECK MAIN GROUNDING WIRE FROM PUMP TO GROUNDING BOLT ON PEDESTAL
THE FOLLOWING FUNCTIONS ARE INOPERABLE BOOM DOWN, EXTEND, HOIST UP	ANTI-2 BLOCK	CHECK CONTINUITY AT A2B PLUG IN THE PEDESTAL WHEN DISCONNECTED ON THE CORD REEL SIDE. SHOULD BE A CLOSED CIRCUIT	VERIFY THAT THE TRAVELING BLOCK IS NOT IN CONTACT WITH BAIL. IF SO, HOIST DN AND CHECK FUNCTIONS AGAIN. INSPECT END OF BOOM TO VERIFY BAIL IS IN CONTACT WITH ANTI-2 BLOCK SWITCH. CHECK BAIL SPRING. CHECK CORD REEL & WIRE ON SIDE OF CRANE FOR DAMAGE.
	CRANE OVERLOAD	CHECK CONTINUITY AT THE PRESSURE SWITCH WHEN DISCONNECTED ON THE PRESSURE SWITCH SIDE. SHOULD BE A CLOSED CIRCUIT	VERIFY LOAD ON CRANE DOES NOT EXCEED MOMENT RATING. REFERENCE LOAD CHART. CHECK PRESSURE ON CYLINDER IN GAUGE PORT— BOOM MUST BE SUPPORTED BEFORE REMOVING GAUGE PORT PLUG. VERIFY SWITCH IS PLUGGED INTO HARNESS.
CRANE ROTATES SLOWLY	ADEQUATE OPERATING CLEARANCES BETWEEN WORM GEAR AND WORM	ROTATION WILL SLOW AT A PARTICULAR POINT ON THE WORM GEAR	SLIGHTLY LOOSEN BOLTS ATTACHING TAPERED BEARINGS TO PEDESTAL. TAP THE BEARING HOUSING USING A HAMMER AWAY FROM THE WORM GEAR. RETIGHTEN BOLTS.
ALL FUNCTIONS OPERATE SLOWLY	LOW TRUCK BATTERY VOLTAGE	WHEN RUNNING A FUNCTION, CHECK VOLTAGE AT HOIST OR HYDRAULIC POWER UNIT. SHOULD NOT DROP BELOW 10V.	VERIFY TRUCK IS RUNNING WHILE OPERATING CRANE CHECK VEHICLE BATTERY FLUID LEVEL CHECK FOR ADEQUATE WIRE SIZING FOR LENGTH AND AMPERAGE REQUIREMENTS

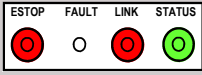
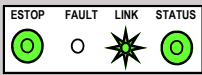
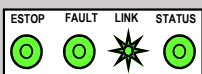
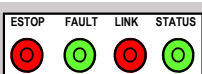
FM CONTROL TRANSMITTER TROUBLESHOOTING

	Tether connection detected
	Low battery. Unit will run approximately 10 hours after Battery light starts flashing.
	Flashing rapidly for 10 seconds indicates a transmitter failure.
	<p>Normal Operation The Active light will flash several times per second, indicating that the transmitter is sending signals to the receiver. The Active light will remain on momentarily whenever a function changes</p>
	<p>Normal Operation The transmitter is in Download Mode.</p>
	Stuck switch detected. Ensure that all switches are in a centered position. The transmitter will not power up when a function is ON.
	<p>On Power Down Unit is still powered. Check for stuck switches, as the transmitter will not power down when a function is ON. Alternating flash means that the transmitter is in Calibration Mode.</p>

Light Legend	Solid	Slow Flash	Fast Flash	Red Light	Green Light	Yellow Light	Alternating Red & Green Light
---------------------	-------	------------	------------	-----------	-------------	--------------	-------------------------------

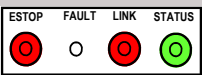
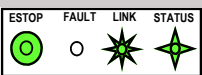
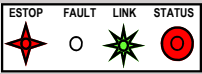
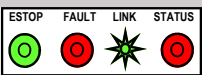
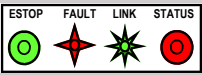
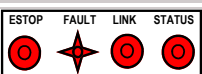
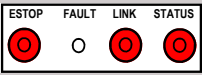
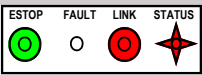
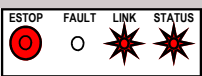
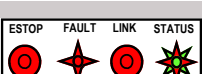
FM CONTROL RECEIVER TROUBLESHOOTING

Normal Operation

	Transmitter is OFF If the transmitter is off, the receiver is operating properly.
	Transmitter is ON When the transmitter is turned on, the Link light (fast flashing) and E-Stop (GREEN) indicates the receiver is operating properly
	Transmitter is in Operation When a function is activated on the transmitter, the Fault light will turn on GREEN. This indicates the receiver is operating properly
	Transmitter is OFF When a latched function is activated then the transmitter is turned off, the Fault light will stay on GREEN. If the system was intentionally designed this way, the receiver is operating properly, if not call for service.

Trouble Indicators

Note: In some cases, the indicator lights will be different depending on whether the transmitter is on or off. Please note the transmitter status in the "Description" column for each case.

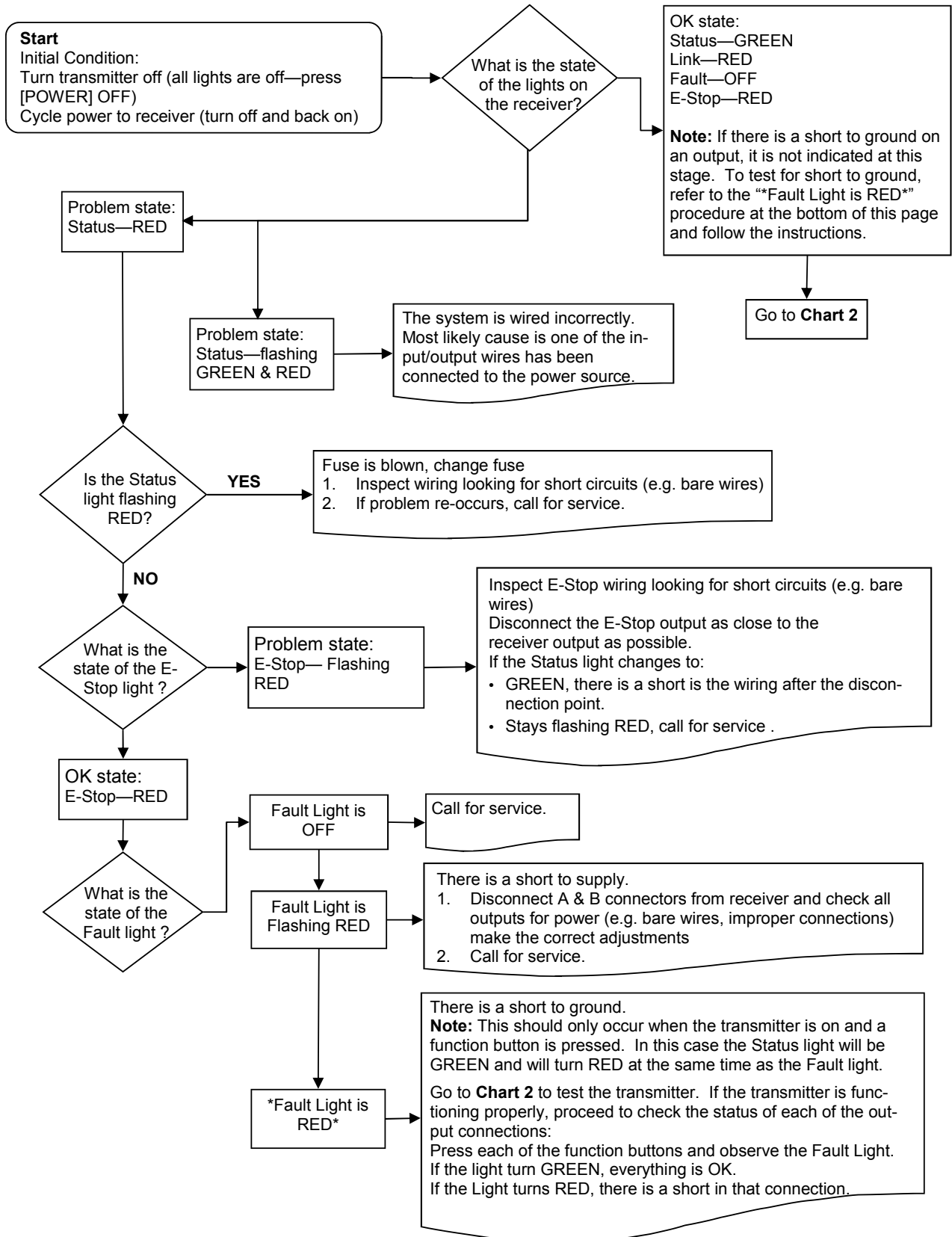
Indicator Lights	Description	Solution
	Transmitter is ON The reason is the transmitter is not communicating with the receiver.	Refer to Trouble Shooting Chart #3 for solutions
	Transmitter is ON A low battery condition has been detected.	To detect intermittent conditions caused by poor or corroded ground or power circuits, the GREEN light will continue to flash for 30 seconds after the condition has been removed.
	Transmitter is ON An internal fault with the E-Stop has been detected.	Check fuse, if OK then: Inspect E-Stop wiring for short circuit. Disconnect E-Stop wire as close to the receiver output as possible. If the Status light changes to: <ul style="list-style-type: none"> GREEN, a short occurs after disconnection point. Stays flashing RED, send it in for service .
	Transmitter is ON A short to ground or excessive current draw on an output. It is most likely caused by a wiring fault.	Ensure transmitter is functioning properly, check status of each output connection: Press each function button and observe Fault Light. <ul style="list-style-type: none"> If GREEN, everything is OK. If RED, there is a short in that connection.
	Transmitter is ON E-Stop output is connected with one of the other outputs or one of the outputs is shorted to power	Turn off transmitter, if condition clears follow E-Stop wire and check for connections with other wires. If condition remains one of the outputs is shorted to power. Test all outputs wires for power.
	Transmitter is OFF A wiring short to the battery has been detected.	Refer to Trouble Shooting Chart #1 for solutions
	Transmitter is OFF The receiver has detected an internal fault.	Refer to Trouble Shooting Chart #1 for solutions
	Transmitter is ON Blown fuse detected. (not functional with proportional units)	Refer to Page 8 for instructions on how to open the receiver case to access fuse. Check wiring for shorts or bare spots. If fuses continue to blow, call for service.
	A setup failure has occurred.	Either hold the Setup button for 5 seconds to return to Setup mode or cycle power to return to the normal operating mode.
	Transmitter is OFF The receiver is powered incorrectly.	Most likely cause of this condition is that an output wire or the E-Stop wire has been connected to a power source while the power wire is disconnected from the Power Input (A6). I.E. Receiver is being powered from an output and not Power Input.

Light Legend

Solid		Slow Flash		Fast Flash		Red Light		Green Light		Yellow Light		Alternating Red & Green Light	
-------	---	------------	---	------------	---	-----------	---	-------------	---	--------------	---	-------------------------------	---

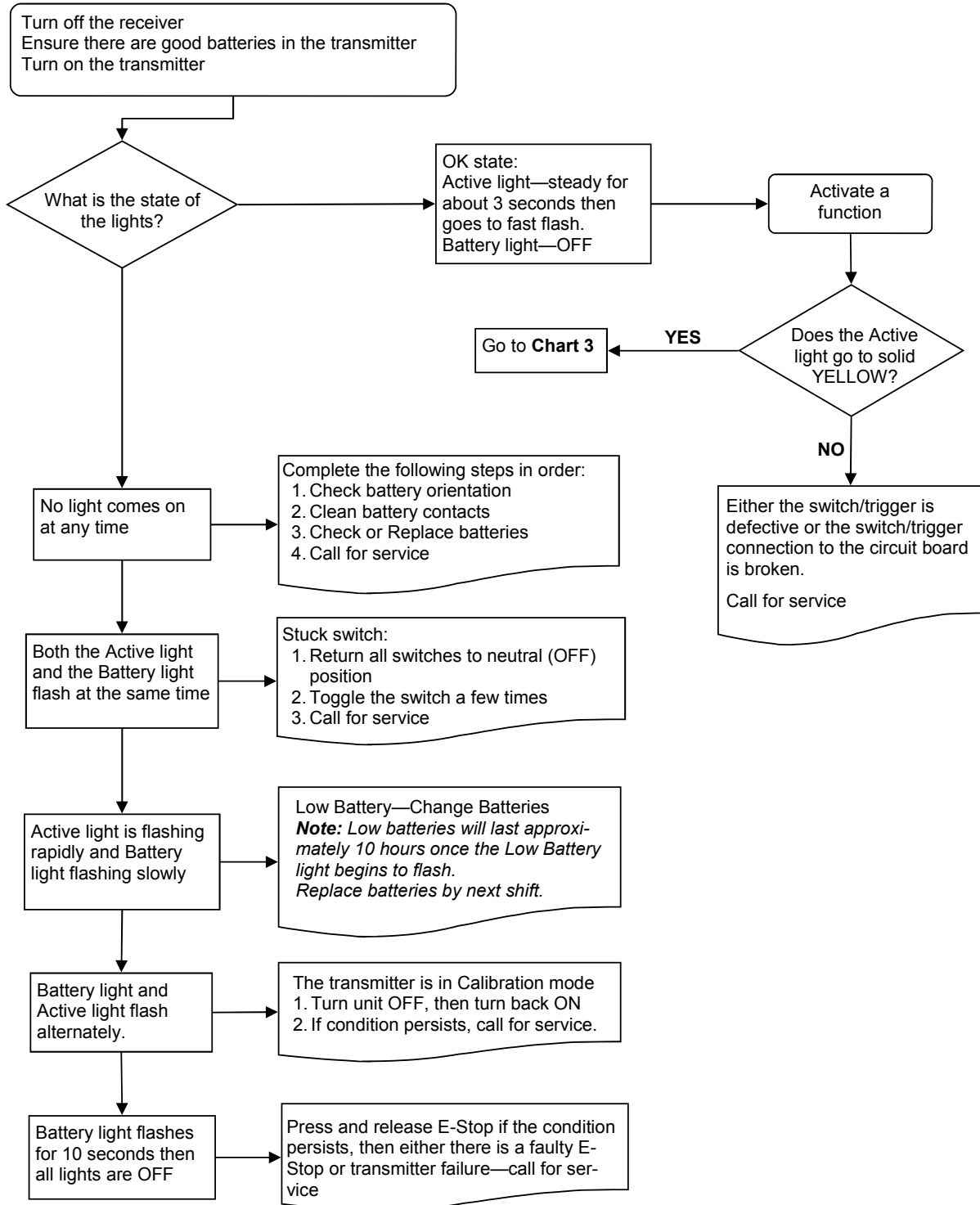
FM CONTROL RECEIVER TROUBLESHOOTING

Test the Receiver—R160



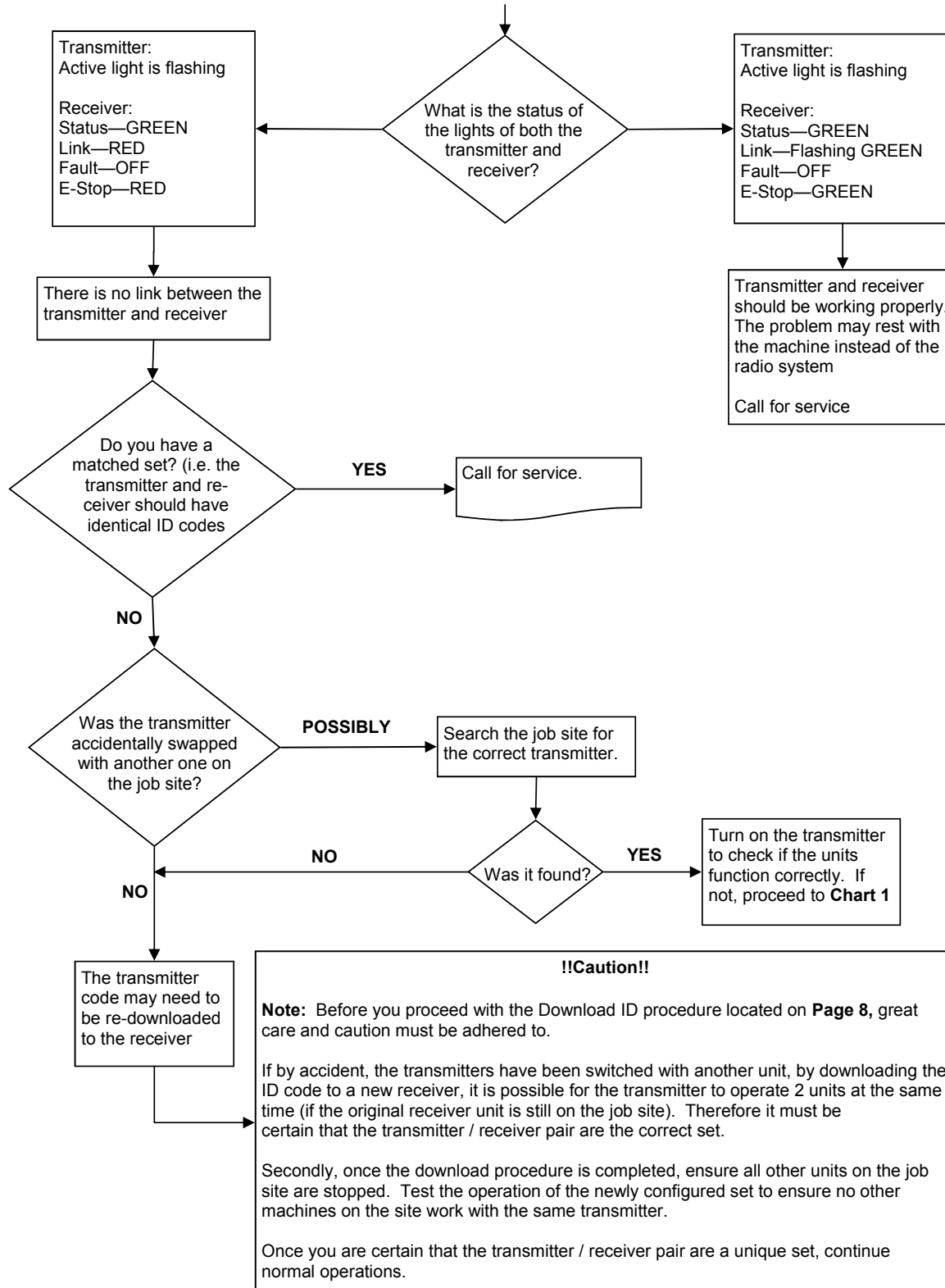
FM CONTROL TRANSMITTER TROUBLESHOOTING

Test the Transmitter—T150



FM CONTROL TROUBLESHOOTING CHART 3

Testing the Transmitter / Receiver Communication



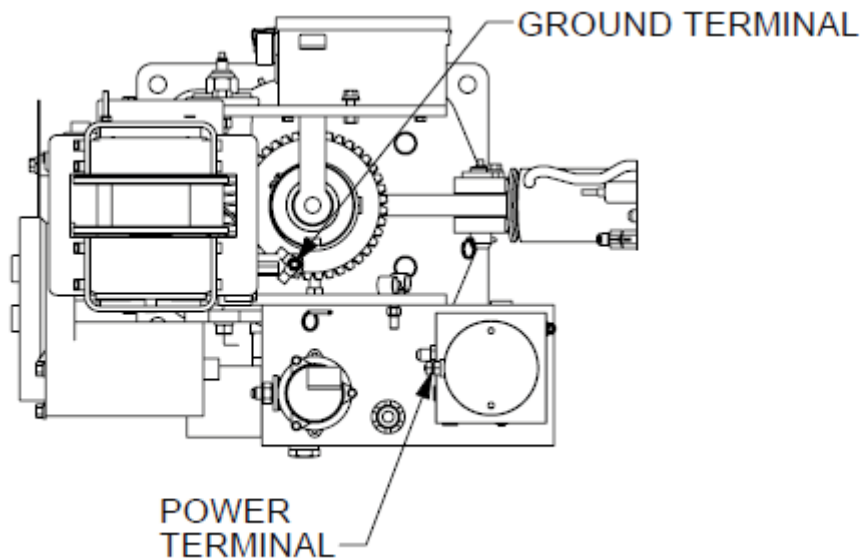
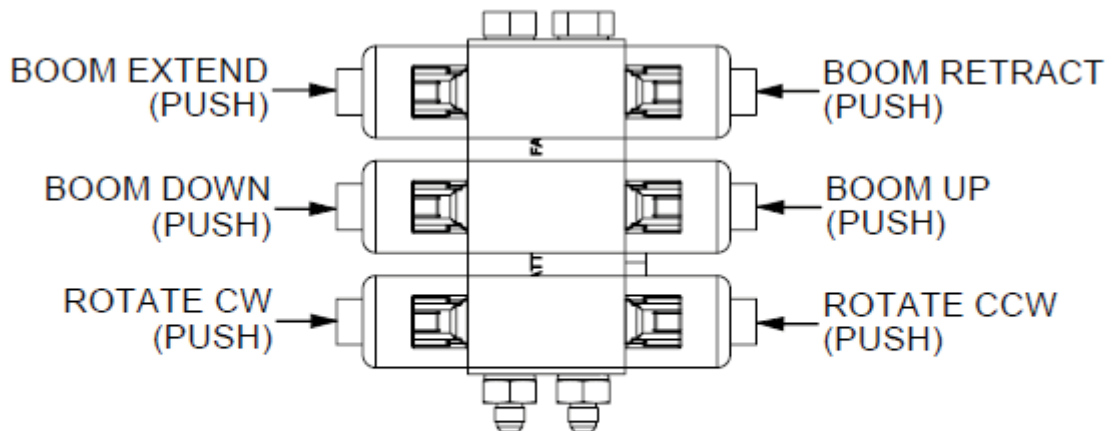
3203EH

HYDRAULIC TROUBLESHOOTING CHART

PROBLEM	POSSIBLE CAUSE	DIAGNOSIS	SOLUTION
CRANE MOVES UNEXPECTEDLY	JAMMED CARTRIDGE	TRY TO MANUALLY OVERRIDE VALVE IF UNABLE TO MOVE STEM. CARTRIDGE IS JAMMED	REPLACE CARTRIDGE
	COUNTER-BALANCE SET TOO LOW (BOOM-UP & BOOM-DN)	ADJUST THE COUNTER-BALANCE OUT TO SEE IF MOVEMENT STOPS.	CONTACT AUTOCRANE FOR PROPER SETTING OF COUNTER-BALANCE. YOU MAY NEED TO REPLACE COUNTER-BALANCE.
	CONTAMINATE IN CARTRIDGE	VALVE STICKS IN CERTAIN POSITIONS	CLEAN CARTRIDGE
NO FUNCTION OPERATES ON CRANE	HYDRAULIC TANK IS LOW OR EMPTY	VISUALLY INSPECT THE HYDRAULIC OIL LEVEL IN THE TANK	FILL TANK TO PROPER LEVEL.
ALL FUNCTIONS OPERATE SLOWLY	FILTER CLOGGED	CHECK FILTER GAUGE LOCATED ON FILTER HOUSING	REPLACE FILTER
EXCESSIVE HEAT DURING OPERATION	OPERATION TIME	CRANE OPERATION IS GENERALLY DESIGNED FOR INTERMITTENT DUTY (7 MIN. LOADED / 30 MIN. COOLDOWN)	REDUCE USE OF CRANE TO ALLOW OIL TO COOL

3203EH

MANUAL OVERRIDE PROCEDURE



MANUAL OVERRIDE PROCEDURES

1. APPLY 12VDC FROM BATTERY TO PUMP POWER TERMINAL
2. APPLY GROUND FROM BATTERY TO GROUNDING CONNECTION
3. SELECT THE FUNCTION DESIRED, THEN PUSH IN OVERRIDE LOCATED ON THE END OF THE COIL USING A PUNCH OR OTHER SMALL OBJECT

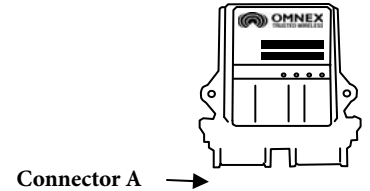
CAUTION: MANUALLY OVERRIDING CRANE BYPASSES ALL SAFETY FEATURES. DURING OPERATION MAKE SURE LOAD DOES NOT EXCEED CRANE CAPACITY AND THE TRAVELING BLOCK DOES NOT COME INTO CONTACT WITH BOOM TIP.

FM CONTROL ID CODE PROGRAMMING

Download ID Code (Use in case of Link Test failure)

!!Caution!!

Note: Before attempting reprogramming with another transmitter, understand that reprogramming the receiver with another transmitter, could result in two receivers on the job site responding to the one transmitter. If the original transmitter was sent in for repair, disconnect the receiver (disconnect connector A) to continue using the machine without remote capability and without fear of inadvertently operating the machine with the other transmitter.



Reprogramming Tips:

1. Use a pointy instrument to depress the Setup button on the receiver (i.e. a pen) as the button is relatively small
2. Follow each step as laid out in the procedure
3. Never lay the receiver circuit board down on anything metallic (there are contact points on the back which could contact the metal and damage the receiver)

Follow these steps to download the transmitter's unique ID Code into the receiver. This will allow the receiver to establish a radio link with that transmitter.

Refer to the Light Legend below for diagram details.

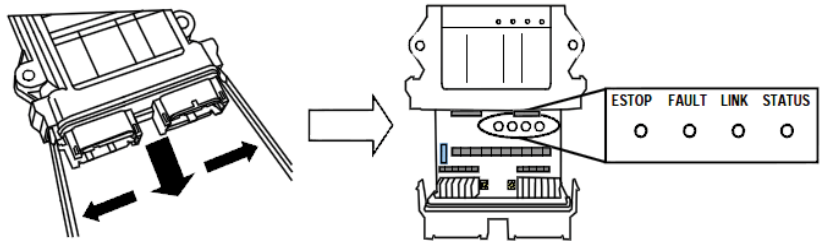
NOTE: It is necessary to download the ID Code when replacing either the transmitter or the receiver.

NOTE: If the transmitter is connected to the receiver with a Tether Cable, completing **only steps 3 and 5** is necessary (it is not necessary to open the R160 case and press the Setup button).

1. Opening the Receiver Case

The cap is held on by two plastic tabs at opposing sides, which can be unlatched as shown using a screwdriver. Once the cap is free, the R160 can slide open.

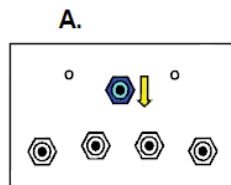
Use a small slotted screwdriver to press the Side Tabs inward.



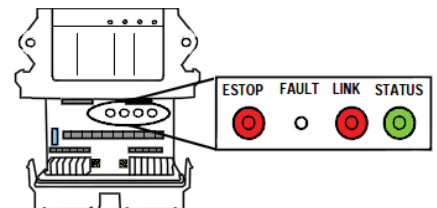
2. Prepare Transmitter, Power Receiver

A. Press [POWER] OFF

B. Supply power to the receiver



B.



Light Legend

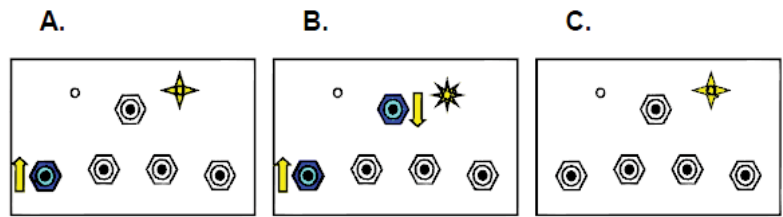
Solid	Slow Flash	Fast Flash	Red Light	Green Light	Yellow Light	Alternating Red & Green Light
-------	------------	------------	-----------	-------------	--------------	-------------------------------

ID CODE PROGRAMMING (CONT.)

FM CONTROL

3. Power Transmitter into Configuration Mode

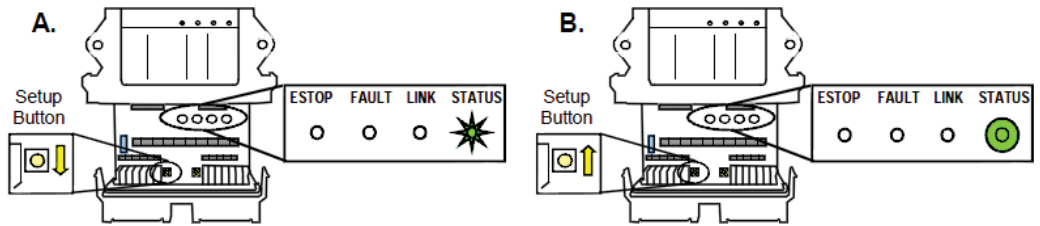
- A. Press & hold [BOOM] switch in the UP position
- B. Press & release [POWER] switch in the OFF position
- C. Release [BOOM] switch



The ACTIVE LED will flash once per second.

4. Put Receiver into Setup

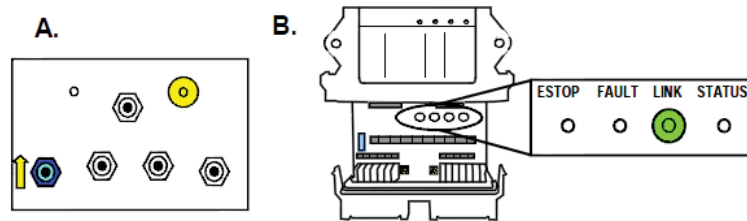
- A. Press & hold [Setup] button until (Status) light goes from slow flash to fast flash
- B. Release [Setup] button. (Status) light goes to solid GREEN, (Link) light turns off



NOTE: If left idle in Setup Mode for over 30 seconds, the receiver will time out. The (Link) light and (Status) light will flash RED rapidly. To return to Setup Mode, repeat step 4.

5. Download ID Code

- A. Press & release [BOOM] switch in the UP position
- B. The R160 (Link) light goes to GREEN. Once complete, (Link) light goes to RED as the transmitter turns off



NOTE: When replacing the receiver cover, ensure the cover snaps completely into place to create a weather proof seal around the base of the receiver.

Light Legend	Solid	Slow Flash	Fast Flash	Red Light	Green Light	Yellow Light	Alternating Red & Green Light
	○	⊛	⊛	●	●	●	⊛

NOTES

CRANE

PREVENTATIVE MAINTENANCE

PAINT FINISH PREVENTIVE MAINTENANCE INSTRUCTIONS

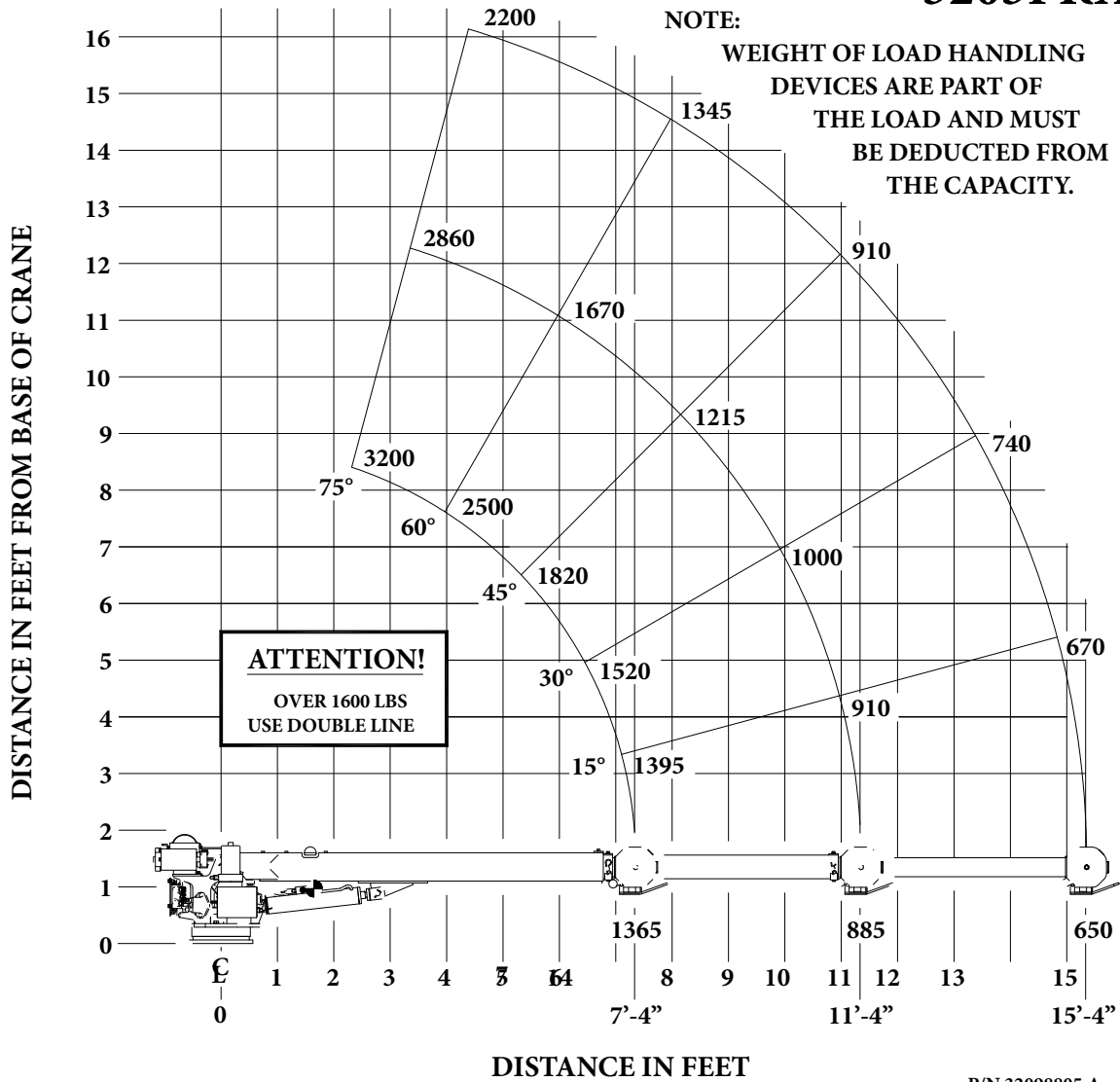
The paint finish on Auto Crane products can become damaged during normal use when chipped, scratched, exposed to harsh chemicals, cleaned with high pressure washers, etc. During periods when the truck is exposed to salt or other corrosive chemicals, Auto Crane products should be washed weekly. The paint finish should be inspected when washed or at least monthly. Any exposed bare metal or visible rust should be repaired immediately. Damaged paint on cranes should be repaired by:

1. Sanding the damaged areas to bare metal.
2. Solvent cleaning the sanded areas to remove sanding residue. Wipe dry with a clean cloth to remove any remaining residue.
3. Priming the sanded areas to a minimum of a 2 mil dry film thickness per the primer manufacturer's instructions. The primer must be compatible with Sherwin Williams' E2W932 epoxy primer.
4. Applying a 2 mil dry film thickness top coat paint per the manufacturer's instructions within 24 hours of applying the primer. The top coat paint must be compatible with Sherwin Williams' E2W932 epoxy primer and Sherwin Williams' Genesis polyurethane top coat paint. The final primer and top coat should have approximately a 4 mil dry film thickness.

3203PR/PRX LOAD CHART

P/N: 320988005

3203PR 3203PRX



P/N 32098805 A



P.O. Box 580697 * Tulsa, OK 74158-0697
4707 N. Mingo Rd. * Phone (918) 438-2760

LIMITED WARRANTY 1 YEAR PURCHASED REPLACEMENT PARTS

Auto Crane will warranty to the consumer for a period of (1) year from the date that a new Auto Crane replacement part was purchased from an authorized Auto Crane distributor. Each new Auto Crane part they sell will be free under normal use and service from defects in material and workmanship. Date of purchase will be honored as the date indicated on the Bill of Sale to the consumer.

The obligation of Auto Crane under this warranty does not apply to parts replaced under the limited warranty for a new Auto Crane product. The warranty for parts replaced under the limited warranty of a new Auto Crane product expires when the warranty for that product expires.

The obligation of Auto Crane under this warranty is limited to the replacement or repair of purchased replacement parts that appear to the manufacturer to be defective after review of documentation (Auto Crane Warranty Claim Form, photos, data, etc.) provided by the Auto Crane distributor and/or inspection of parts returned to Auto Crane. This warranty does not obligate Auto Crane to bear labor costs to replace the defective parts or travel time charges in connection with the replacement or repair of defective parts. Responsibility for customer's claims arising from misapplication, abuse, misuse or alteration of equipment or parts lies with the distributor or user and no warranty obligation is assumed in these circumstances by Auto Crane.

Auto Crane will in no event be liable for any consequential damages or contingent liabilities arising out of the failure of any Auto Crane product or parts to operate properly.

Auto Crane makes no warranty in respect to parts for component accessories, it being subject to the warranties of their respective manufacturers.

If field service, at the request of the distributor, is rendered and fault is found not to be with Auto Crane's product, the distributor shall pay the time and expense of the field representative.

Claims for service labor or other expenses that have incurred by the buyer without approval or authorization or Auto Crane will not be accepted.

When applying for warranty, claims may be handled by contacting your nearest authorized Auto Crane **Distributor**. **All claims are to be filed in writing on an Auto Crane Warranty Claim Form.**



P.O. Box 580697 * Tulsa, OK 74158-0697
4707 N. Mingo Rd. * Phone (918) 836-0463

LIMITED WARRANTY 2 YEAR PARTS AND LABOR

Auto Crane will warranty to the consumer for a period of (2) years parts and labor from the date of purchase. Each new Auto Crane unit they sell will be free under normal use and service from defects in material and workmanship. Date of purchase will be honored as the date indicated on the Bill of Sale, which must accompany the Warranty Registration and be on file with Auto Crane. Absent a valid Warranty Registration and appropriate documentation, the original date of manufacture, as indicated by the serial number on the product, will be used to determine the effective date of the 2 year warranty.

The obligation of Auto Crane under this warranty is limited to the replacement or repair of parts that appear to the manufacturer after review and/or inspection to be defective and paid flat rate labor for replacing defective parts. This warranty does not obligate Auto Crane to bear the travel time charges in connection with the replacement or repair of defective parts. Responsibility for customer's claims arising from misapplication, abuse, misuse or alteration of equipment or parts lies with the distributor or user and no warranty obligation is assumed in these circumstances by Auto Crane.

Auto Crane will in no event be liable for any consequential damages or contingent liabilities arising out of the failure of any Auto Crane Product or parts to operate properly.

Auto Crane makes no warranty in respect to component accessories, it being subject to the warranties of their respective manufacturers.

If field service, at the request of the distributor, is rendered and fault is found not to be with Auto Crane's product, the distributor shall pay the time and expense of the field representative.

Claims for service labor or other expenses that have incurred by the buyer without approval or authorization or Auto Crane will not be accepted.

When applying for warranty, claims may be handled by contacting your nearest authorized Auto Crane Distributor. All claims are to be filed in writing on an Auto Crane Warranty Claim Form.

AUTO CRANE COMPANY IS UNDER NO OLIGATION TO EXTEND THIS WARRANTY TO ANY CUSTOMER FOR WHICH AN AUTO CRANE DELIVERY REPORT FORM HAS NOT BEEN COMPLETED AND ON FILE WITH AUTO CRANE COMPANY

Note: This manual should remain with the crane at all times.

Auto Crane will not assume responsibility or liability for any modifications or changes made to unit, or installation of component parts without authorization.

Auto Crane Company issues a limited warranty certificate with each unit sold. See last page for warranty.

