

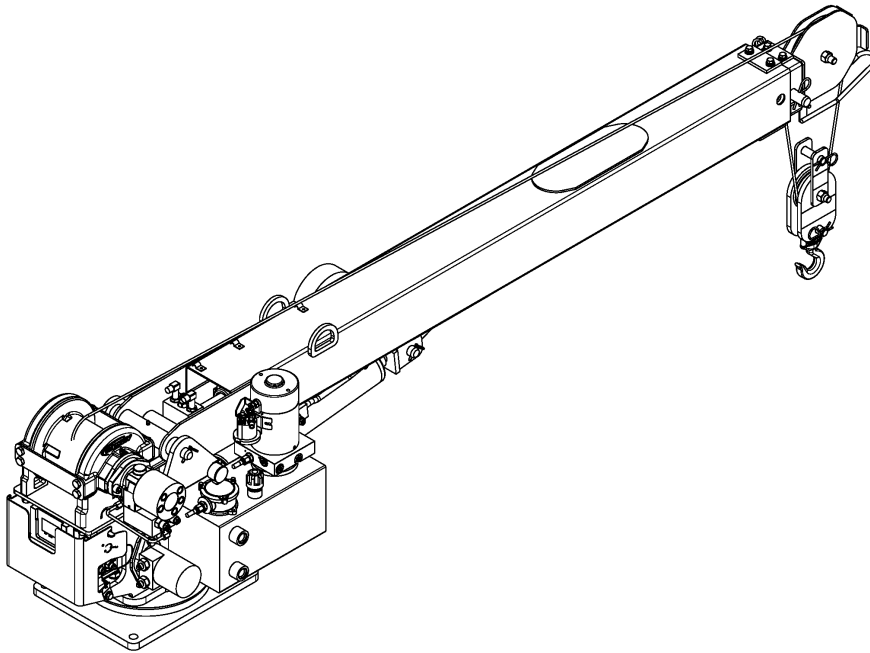

# 3203EH NEXSTAR OWNERS MANUAL

Manual No. 320991031



Serial No. \_\_\_\_\_

Mailing Address:  
P.O. Box 580697  
Tulsa, OK 74158-0697  
Physical Address:  
4707 N. Mingo Rd.  
Tulsa, OK 74117-5904

Phone 1-800-777-2760  
Fax (918) 269-6688  
<http://www.autocrane.com>



# Auto Crane Warranty Registration

Fax Transmission

To: Warranty Department Fax: (918) 834-5979  
 From: \_\_\_\_\_ Date: \_\_\_\_\_  
 Re: Product Registration Pages: \_\_\_\_\_

**End User Information:** (Required for Warranty Activation)

Name: \_\_\_\_\_ Phone: \_\_\_\_\_  
 Address: \_\_\_\_\_  
 City: \_\_\_\_\_ State: \_\_\_\_\_ Zip: \_\_\_\_\_  
 Contact: \_\_\_\_\_ E-mail Address: \_\_\_\_\_

**Distributor Information:** (Required for Warranty Activation)

Name: \_\_\_\_\_  
 Address: \_\_\_\_\_  
 City: \_\_\_\_\_ State: \_\_\_\_\_ Zip: \_\_\_\_\_  
 Contact: \_\_\_\_\_ E-mail Address: \_\_\_\_\_

**Product Information:** (Required for Warranty Activation)

Model No.: \_\_\_\_\_ Serial No.: \_\_\_\_\_  
 Date Product Delivered: \_\_\_\_\_ Date Processed: \* \_\_\_\_\_  
 VIN # \_\_\_\_\_ \* For Auto Crane use only

## ONE REGISTRATION FORM PER UNIT (CRANE OR BODY)

Registration form must be mailed or faxed within 15 days of customer installation.

Mail to:  
 Warranty Department  
 Auto Crane Company  
 P.O. Box 581510  
 Tulsa, OK 74158-0697

# 3203EH

## OWNER'S MANUAL REVISION RECORD

Revision Date	Section(s) Or Page(s)	Description of Change
01/24/2012	3-2	ADDED TEMPERATURE RANGE
05/22/2012	7-3,4,5,6,7; 7-13,14	CHANGED PEDESTAL & HOIST FOR FINAL PRODUCTION RELEASE
	8-2,4	UPDATED WIRING HARNESS

**Notes:**

1. The information contained in this manual is in effect at the time of this printing. It does not cover all instructions, configurations, accessories, etc. If you require additional information, please contact **Auto Crane Company** at **1-800-777-2760**.
2. **Auto Crane Company** reserves the right to update this material without notice or obligation.

# WARNINGS

**WARNING!** Federal law (49 cfr part 571) requires that the Final Stage Manufacturer of a vehicle certify that the vehicle complies with all applicable federal regulations. Any modifications performed on the vehicle prior to the final state are also considered intermediate stage manufacturing and must be certified as to compliance. The installer of this crane and body is considered one of the manufacturers of the vehicle. As such a manufacturer, the installer is responsible for compliance with all applicable federal and state regulations, and is required to certify that the vehicle is in compliance.

**WARNING!** It is the further responsibility of the installer to comply with the OSHA Truck Crane Stability Requirements as specified by 29 CFR part 1910.180 (C) (1).

**WARNING! NEVER OPERATE THE CRANE NEAR ELECTRICAL POWER LINES!**

**Death** or serious injury will result from boom, line, or load contacting electric lines. Do not use crane within 10 feet (3.05m) of electric power lines carrying up to 50,000 volts. One-foot additional clearance is required for every additional 30,000 volts or less. **SEE DANGER DECAL (P/N 040529)** in this Owner's Manual.

**WARNING! NEVER.....**

- **EXCEED** load chart capacities (centerline of rotation to hoist hook).
- Un-reel last 5 wraps of cable from drum!
- Wrap cable around load!
- Attempt to lift or drag a load from the side! The boom can fail far below its rated capacity.
- Weld, modify, or use unauthorized components on any Auto Crane unit! This will void any warranty or liability. Also failure of the crane may result.
- Place a chain link on the tip of the hook and try to lift a load!
- Use a sling bar or anything larger than the hook throat that could prevent the hook latch from closing, thus negating the safety feature!
- Hold on any pendant Select Switch that will cause unsafe operating conditions!

**WARNING!** In using a hook with latch, **ALWAYS** make sure that the hook throat is closed before lifting a load! Proper attention and common sense applied to the use of the hoist hook and various slings will prevent possible damage to material being hoisted and may prevent injury to personnel.

**WARNING!** Failure to correctly plumb and wire crane can cause inadvertent operation and damage to crane and/or personnel!

**WARNING!** Auto Crane Company remote controlled cranes are not designed or intended for use for any applications involving the lifting or moving of personnel.

**WARNING! ALWAYS** operate the crane in compliance with the load capacity chart. **DO NOT USE** the overload shutdown device to determine maximum rated loads, if the crane is equipped with this type of device.

**READ THIS PAGE**

# **3203EH**

## ***TABLE OF CONTENTS***

INTRODUCTION	1-1.0
GENERAL SPECIFICATIONS	1-3.0
SAFETY TIPS AND PRECAUTIONS	2-1.0
OPERATING PRACTICES & WARNINGS	2-3.0
QUALIFICATIONS FOR OPERATORS	2-4.0
OPERATION OF UNIT / OUTRIGGERS	3-1.0
CRANE OPERATION	3-3.0
INSPECTION REQUIREMENTS	4-1.0
TESTING REQUIREMENTS	4-3.0
REPAIRS & MAINTENANCE	4-4.0
BATTERIES	4-6.0
LUBRICATION AND MAINTENANCE SCHEDULE	4-8.0
SAFETY DECAL SECTION	5-1.0
GENERAL DIMENSIONS	6-1.0
MOUNTING AND INSTALLATION	6-2.0
GENERAL ASSEMBLY	7-1.0
PEDESTAL ASSEMBLY	7-3.0
BOOM ASSEMBLY	7-9.0
HOIST ASSEMBLY	7-13.0
TRAVELING BLOCK ASSEMBLY	7-16.0
MAIN WIRING HARNESS	8-1.0
HYDRAULIC CONTROL VALVE	8-5.0
POWER UNIT	8-9.0
VALVE OVERRIDE OPERATION	9-1.0
TROUBLESHOOTING CHART	9-2.0
CARTRIDGE MAINTENANCE	9-8.0
LOAD CHART	9-9.0
WARRANTY	LAST PAGE

# 3203EH

## INTRODUCTION

Auto Crane products are designed to provide many years of safe, trouble-free, dependable service when properly used and maintained.

To assist you in obtaining the best service from your crane and to avoid untimely crane and/or vehicle failure, this manual provides the following operating and service instructions. It is specifically recommended that all operating and service personnel consider this manual as mandatory material for reading and study before operating or servicing Auto Crane products. It is highly recommended that crane owners, equipment managers, and supervisors also read this manual.

Auto Crane has incorporated several safety features in the 3203EH crane for your protection.

For your convenience the overall dimensions of the 3203EH crane are included on the General Dimension Drawing. Rotation and turning radius are also listed on that drawing.

Remember, the crane adds weight to the vehicle. Adding weight may change the driving and riding characteristics of the vehicle unless the appropriate overload spring(s) are installed on the truck. The payload of the vehicle is reduced by the weight of the crane. The operator should exercise care when loading the vehicle. Distributing the payload on the vehicle evenly will greatly improve the driving and riding characteristics of the vehicle.

***Auto Crane Company issues a limited warranty certificate with each unit sold. See last page for warranty.***

The 3203EH cranes are attached to your 12-volt truck electrical system through the relay provided. The 3203EH is another highly efficient Auto Crane product. The use of a maintenance-free battery is not recommended on any Auto Crane product. The recommended alternator and battery that will give the longest life with the most useful duty cycle is a 75-Amp alternator with a 500 cold cranking amp battery. These specifications should be considered minimum.

It has always been Auto Crane Company policy to handle all warranty claims we receive as promptly as possible. If a warranty claim involves discrepant material or workmanship, Auto Crane will take immediate corrective action. It is understandable that Auto Crane Company cannot assume responsibility of liability when it is obvious that our products have been abused, misused, overloaded or otherwise damaged by inexperienced persons trying to operate the equipment without reading the manual.

***Auto Crane will not assume responsibility or liability for any modifications or changes made to unit, or installation of component parts without authorization.***

Auto Crane maintains a strong distributor network and a knowledgeable Customer Service Department. In most cases, an equipment problem is solved via phone conversation with our customer service department. The customer service department also has the ability to bring a local distributor, a regional sales manager, or a factory serviceman into the solution of an equipment problem.

If, through no fault of Auto Crane Company, it is necessary to send an experienced factory serviceman on a field service call the rates stated in the Auto Crane Distributor's Flat Rate Manual will apply.

Auto Crane Company's extensive Research and Development Program allow our customers to use the best equipment on the market. Our Engineering Staff and our knowledgeable sales people are always available to our customers in solving crane and winch-type application problems. When in doubt, call the Auto Crane factory.

***Note: This manual should remain with the crane at all times.***

# 3203EH

## ***INTRODUCTION***

### **DISTRIBUTOR ASSISTANCE:**

Should you require any assistance not given in this manual, we recommend that you consult your nearest Auto Crane Distributor. Our distributors sell authorized parts and have service departments that can solve almost any needed repair. This manual does not cover all maintenance, operating, or repair instructions pertinent to all possible situations.

**If you require additional information, please contact the Auto Crane Company at the following telephone number: 1-800-777-2760.**

The information contained in the manual is in effect at the time of this printing. Auto Crane Company reserves the right to update this material without notice or obligation.

# 3203EH

## **GENERAL SPECIFICATIONS**

### **DIMENSIONS**

Width: 20.63 in (0.52 m)

Height: 25.50 in (0.65 m)

Length: 7 ft 4 in (2.24 m)  
[booms stored]

Weight: 840 lbs (382 kg)

### **CAPACITY**

10,000 ft-lbs (1.38 ton-m)

[ft-lbs = horizontal distance from centerline of rotation to free hanging weight (feet) x amount of weight (pounds)]

<b>LIFTING CAPACITIES</b>			
ft	lbs	ft	lbs
2	3,200	9	1,100
3	3,200	10	1,000
4	2,500	11	900
5	2,000	12	830
6	1,670	13	770
7	1,500	14	710
8	1,250	15	660

### **REACH**

Second boom will reach from 7ft-4in to 11ft-4in.

Third boom will reach from 11ft-4in to 15ft-4in.

### **CABLE**

62 ft (20.6 m) of 7/32 in (5.56 mm) diameter aircraft quality cable. This cable has a single line breaking strength of 5,600 lbs (2,540 kg).

### **CHASSIS REQUIREMENTS**

8,800 lbs (4,000 kg) GVWR min

201,600 in-lbs RBM

### **ELECTRICAL SYSTEM REQUIREMENTS**

**Voltage:** 12 Volt DC

**Alternator:** 75 Amp (min.)

**Battery:** 625 Cold Cranking Amp (min.)  
130 minute reserve capacity (min.)  
Maintenance Type

### **ROTATION**

360° Continuous



# —IMPORTANT— SAFETY TIPS AND PRECAUTIONS

1. No unqualified or unauthorized person shall be allowed to operate the crane.
2. **WARNING:** Never weld, modify, or use unauthorized components / parts on any Auto Crane unit. This will void any warranty or liability. Also, failure of the crane may result.
3. Make certain the vehicle meets minimum chassis requirements. (These requirements do not guarantee unit stability.)
4. Make certain the crane is installed per factory specifications. Contact your local distributor or the Auto Crane factory if any questions arise.
5. Visual inspections and tests should be conducted at the beginning of each shift each day to insure that the crane and all its operating systems are in good condition and working order before it is used.
6. Inspect hydraulic hoses frequently for signs of deterioration, and replace them as required.
7. If a hydraulic break occurs, leave the area of the break and do not attempt to stop the break by hand as the hydraulic oil may be hot and under high pressure which can cause serious injury. Shut the system down as soon as possible.
8. Check the hook at least every thirty days for distortions or cracks and replace it as required.
9. Oil gears as required.
10. Stop all operations when cleaning, adjusting or lubricating the machine.
11. Keep dirt and grit out of moving parts by keeping crane clean. Make sure machine is free of excess oil, grease, mud and rubbish, thus reducing accidents and fire hazards.
12. When a new cable is installed, operate first with a light load to let the cable adjust itself.
13. Locate the vehicle at the work site for the best stability possible.
14. Keep the vehicle in a level position while loading or unloading.
15. Observe operating area for obstructions and/or power lines that might be a hazard.
16. **WARNING: NEVER OPERATE THE CRANE NEAR ELECTRICAL POWER LINES.** Auto Crane Company recommends that the crane never be any closer to a power line (including telephone lines) than 10 feet at any point.
17. Allow the vehicle engine to warm up before operating crane.
18. Know the weight of your rigging and load to avoid overloading the crane.
19. Deduct the weight of the load handling equipment from the load rating to determine how much weight can be lifted.
20. All load ratings are based on crane capacity, NOT the vehicle stability. Remember in lifting a heavy load, the weight can create enough tipping moment to overturn the vehicle
21. Always comply with load chart capacities, (centerline of rotation to hook).
22. Secure all loads before lifting.
23. Always set the emergency brake before beginning operation.
24. Keep objects and personnel clear of crane path during operation.
25. Operate controls slowly and smoothly in order to meter oil flow for safe operation.
26. Always extend the outriggers from vehicle to the ground before crane operation. Ensure that they are firmly positioned on solid footings. Stand clear of outriggers while they are being extended.
27. If any outrigger, when extended, rests on a curb or other object that prevents it from extending to its maximum distance, shorten bearing or fulcrum point and reduce the maximum load accordingly.
28. When an outrigger will not reach the ground due to holes or grades, it shall be blocked up to provide level and firm support for the truck.

## WARNING!

Auto Crane Company cranes are not designed or intended for use in lifting or moving persons. Any such use shall be considered to be improper and the seller shall not be responsible for any claims arising there from. This sale is made with the express understanding that there is no warranty that the goods shall be fit for the purpose of lifting or moving persons or other improper use and there is no implied warranty or responsibility for such purposes.

# —IMPORTANT— SAFETY TIPS AND PRECAUTIONS

29. When working in soft earth, use wide pads under outrigger feet to prevent sinking.
30. Always store outriggers before transportation.
31. Always store the crane in its stowed position for transportation.
32. Remember the overall height of the entire unit for garage door clearance or when moving under objects with low overhead clearance
33. Disengage power takeoff (PTO) before moving the vehicle. (Not applicable to electric-hydraulic cranes.)
34. Always walk around the vehicle before moving.
35. Never drive with a load suspended from crane.
36. Do not take your eyes off a moving load. Look in the direction you are moving.
37. Never swing a load over people.
38. Do not stop the load sharply in midair so that it swings like a pendulum. Meter the controls to avoid this situation.
39. Crane boom length should be kept as short as possible for maximum lifting capacity and greater safety. Longer booms require additional care in accelerating and decelerating the swing motion, and thus slow down the working cycle and reduce productivity.
40. Keep the load directly and vertically under the boom point at all times. Crane booms are designed to handle vertical loads, not side lifts.  
**WARNING:** Never attempt to lift, drag, tow or pull a load from the side. The boom can fail far below its rated capacity.
41. Do not push down on anything with boom extensions; similarly do not lift anything with boom extensions.
42. Do not lift personnel with any wire rope attachment or hook. There is no implied warranty or responsibility for such purposes.
43. **WARNING:** In using a safety hook, ALWAYS close the hook throat before lifting a load. Proper attention and common sense applied to the use of the hook and various slings will prevent possible damage to material being hoisted and may prevent injury to personnel.
44. **WARNING:** Never place a chain link on the tip of the hook and try to lift a load with the hoist.
45. **WARNING:** Never use a sling bar or anything larger than the hook throat which could prevent the safety latch from closing, thus negating the safety feature.
46. Do not wrap the wire rope around sharp objects when using winch.
47. **WARNING:** Never unreel the last 5 wraps of cable from drum.

# —IMPORTANT— OPERATING PRACTICES AND WARNINGS

1. Make certain the vehicle meets minimum chassis requirements. (These requirements do not guarantee unit stability)
2. Make certain the crane is installed per factory specifications. Contact your local Distributor or the Auto Crane factory if any questions arise.
3. Keep the vehicle in as level a position as possible while loading or unloading.
4. **ALWAYS** set the vehicle emergency brake before beginning crane operations.
5. **ALWAYS** use outriggers from vehicle to the ground during crane operation. Make sure they are firmly positioned on solid footings.
6. All load ratings are based on crane capacity, **NOT** truck/crane stability.
7. Keep objects and personnel clear of crane path during operation.
8. Keep hoist cable pulled tight at all times.
9. **REMEMBER**, in lifting a heavy load, the weight can create enough tipping momentum to overturn the vehicle.
10. **ALWAYS** keep load as close to ground as possible.
11. Hydraulic hoses need to be inspected frequently for signs of deterioration, and be replaced as required.
12. The hoist hook is an important item that an operator should consider and use properly. It should be checked on a daily basis for distortion or cracks.
13. **ALWAYS** store outriggers before road travel.
14. **WARNING! NEVER OPERATE THE CRANE NEAR ELECTRICAL POWER LINES!** Death or serious injury will result from boom, line, or load contacting electric lines. Do not use crane within 10 feet (3.05m) of electric power lines carrying up to 50,000 volts. One foot additional clearance is required for every additional 30,000 volts or less.
15. **WARNING! NEVER EXCEED** load chart capacities (centerline of rotation to hoist hook).
16. **WARNING! NEVER** un-reel last 5 wraps of cable from drum!
17. **WARNING! NEVER** wrap cable around load!
18. **WARNING! NEVER** attempt to lift or drag a load from the side! The boom can fail far below its rated capacity.
19. **WARNING! NEVER** weld, modify, or use unauthorized components on any Auto Crane unit! This will void any warranty or liability. Also failure of the crane may result.
20. **WARNING! NEVER** place a chain link on the tip of the hook and try to lift a load!
21. **WARNING! NEVER** use a sling bar or anything larger than the hook throat that could prevent the hook latch from closing, thus negating the safety feature!
22. **WARNING!** In using a hook with latch, **ALWAYS** insure that the hook throat is closed before lifting a load! Proper attention and common sense applied to the use of the hoist hook and various slings will prevent possible damage to material being hoisted and may prevent injury to personnel.
23. **WARNING! NEVER** hold any Control Select Switch on that will cause unsafe operating conditions!

## **WARNING!**

**Auto Crane Company remote controlled, stiff boom cranes are not designed or intended for use on any applications involving the lifting or moving of personnel.**

# **QUALIFICATIONS FOR AND CONDUCT OF OPERATORS AND OPERATING PRACTICES**

## **REFERENCE ASME B30.5a AND OSHA 1910.180 FOR COMPLETE QUALIFICATION REQUIREMENTS**

### **OPERATORS**

1. Crane operation shall be limited to personnel with the following minimum qualifications:
  - A. Designated persons.
  - B. Trainees under the direct supervision of a designated person.
  - C. Maintenance and test personnel (when it is necessary in the performance of their duties).
  - D. Inspectors (crane).
2. No one other than the personnel specified above shall enter the operating area of a crane with the exception of persons such as oilers, supervisors, and those specified persons authorized by supervisors whose duties require them to do so and then only in the performance of their duties and with the knowledge of the operator or other persons.

### **QUALIFICATIONS FOR OPERATORS**

1. Operators shall be required by the employer to pass a practical operating examination. Qualifications shall be limited to the specific type of equipment for which examined.
2. Operators and operator trainees shall meet the following physical qualifications:
  - A. Vision of at least 20/30 Snellen in one eye and 20/50 in the other, with or without corrective lenses.
  - B. Ability to distinguish colors, regardless of position, if color differentiation is required for operation.
  - C. Adequate hearing with or without hearing aid for the specific operation.
3. Evidence of physical defects or emotional instability, which render a hazard to operator or others, which in the opinion of the examiner could interfere with the operator's performance, may be sufficient cause for disqualification. In such cases, specialized clinical or medical judgment and tests may be required.
4. Evidence that operator is subject to seizures or loss of physical control shall be sufficient reason for disqualification. Specialized medical tests may be required to determine these conditions.

5. Operators and operator trainees should have normal depth perception, coordination, and no tendencies to dizziness or similar undesirable characteristics.
6. In addition to the above listed requirements, the operator shall:
  - A. Demonstrate the ability to comprehend and interpret all labels, operator's manuals, safety codes, and other information pertinent to correct crane operations.
  - B. Posses the knowledge of emergency procedures and implement it.
  - C. Demonstrate to the employer the ability to operate the specific type of equipment.
  - D. Be familiar with the applicable safety regulations.
  - E. Understand the operating procedures as outlined by the manufacturer.
  - F. Be thoroughly familiar with the crane and its control functions.
  - G. Understand the operating procedures as outlined by the manufacturer.

### **CONDUCT OF OPERATORS**

1. The operator shall not engage in any practice, which will divert his attention while actually operating the crane.
2. Each operator shall be responsible for those operations under the operator's direct control. Whenever there is any doubt as to safety, the operator shall consult with the supervisor before handling the loads.
3. The operator should not leave a suspended load unattended unless specific precautions have been instituted and are in place.
4. If there is a warning sign on the switch or engine starting controls, the operator shall not close the switch or start the engine until the warning sign has been removed by the appointed person.
5. Before closing the switch or starting the engine, the operator shall see that all controls are in the "OFF" or neutral position and all personnel are in the clear.

# QUALIFICATIONS FOR AND CONDUCT OF OPERATORS AND OPERATING PRACTICES

6. If power fails during operation, the operator shall:
    - A. Move power controls to the "OFF" or neutral position.
    - B. Land the suspended load and boom, if practical.
  7. The operator shall be familiar with the equipment and its proper care. If adjustments or repairs are necessary, the operator shall report the same promptly to the appointed person, and shall also notify the next operator.
  8. The operator at the start of each shift shall test all controls. If any controls do not operate properly, they shall be adjusted or repaired before operations are begun.
  9. Stabilizers shall be visible to the operator while extending or setting unless a signal person assists operator.
- E. During lifting care shall be taken that:
    - i. There is no sudden acceleration or deceleration of the moving load.
    - ii. Load, boom or other parts of the crane do not contact any obstruction.
  - F. Cranes shall not be used for dragging loads sideways.
  - G. This standard recognizes that telescopic boom cranes are designed and intended for handling materials. They do not meet personnel lift or elevator requirements. Therefore, no lifting, lowering, swinging or traveling shall be done while a person is on the hook or load. Hook attached suspended work platforms (baskets) shall not be used with cranes covered by this standard. Crane manufacturer must approve work platforms attached to the boom.
  - H. The operator should avoid carrying loads over people.

## **OPERATING PRACTICES/HANDLING THE LOAD**

1. Size of load.
  - A. No crane shall be loaded beyond the rated load except for test purposes
  - B. The load to be lifted is to be within the rated load of the crane and its existing configuration.
  - C. When loads that are not accurately known are to be lifted, the person responsible for the job shall ascertain that the weight of the load does not exceed the crane rated load at the radius at which the load is to be lifted.
2. Attaching the load.
  - A. The load shall be attached to the hook by means of slings or other devices of sufficient capacity.
  - B. Hoist rope shall not be wrapped around the load.
3. Moving the load.

The operator shall determine that:

  - A. The crane is level and, where necessary, the vehicle/carrier is blocked properly.
  - B. The load is well secured and balanced in the sling or lifting device before it is lifted more than a few inches.
  - C. Means are provided to hold the vehicle stationary while operating the crane.
  - D. Before starting to lift, the hook shall be positioned over the load in such a manner as to minimize swinging.
4. Stowing procedure – Follow the manufacturer's procedure and sequence when stowing and unstowing the crane.
  - I. When the crane is so equipped, the stabilizers shall be fully extended and set. Blocking under stabilizers shall meet the requirements as follows:
    - i. Strong enough to prevent crushing.
    - ii. Of such thickness, width and length as to completely support the stabilizer pad.
  - J. Firm footing under all tires, or individual stabilizer pads should be level. Where such a footing is not otherwise supplied, timbers, cribbing, or other structural members to distribute the load so as to not exceed allowable bearing capacity or the underlying material should provide it.
  - K. In transit, the boom shall be carried in stowed position.
  - L. When rotating the crane, sudden starts and stops shall be avoided. Rotational speed shall be such that the load does not swing out beyond the radius at which it can be controlled.
  - M. The crane shall not be transported with a load on the hook unless recommended by the manufacturer.
  - N. No person should be permitted to stand or pass under a suspended load.

# QUALIFICATIONS FOR AND CONDUCT OF OPERATORS AND OPERATING PRACTICES

## MISCELLANEOUS

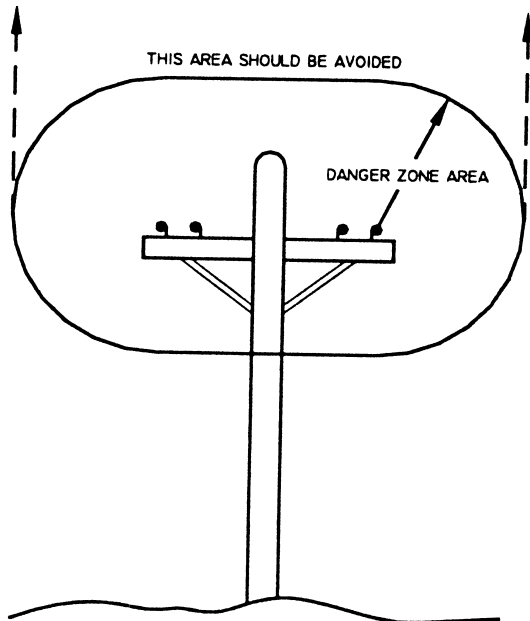

## OPERATING NEAR ELECTRICAL POWER LINES

1. Cranes shall be operated so that no part of the crane or load enters into the danger zone shown above.

### EXCEPTIONS

- A. The danger zone may be entered after confirmation by an appointed person that the electrical distribution and transmission lines have been de-energized and visibly grounded at the point of work; or
  - B. The danger zone may be entered if insulating barriers (that are neither a part of nor an attachment to the crane) have been erected to prevent physical contact with the lines.
2. For lines rated 50 kV or below, minimum clearance between the lines and any part of the crane or load (including handling appendages) shall be 10-ft. (3m). For higher voltages, see Table 1.
  3. Caution shall be exercised when working near overhead lines, because they can move horizontally or vertically due to wind, moving the danger zone to new positions.
  4. In transit with no load and boom lowered the clearance shall be specified in Table 1.

5. A qualified signalperson shall be assigned to observe the clearance and give warning before approaching the above limits.
  - A. Any overhead wire shall be considered to be an energized line unless and until the person owning such line or the electrical utility authorities verify that it is not an energized line.
  - B. Exceptions to this procedure are allowed, if approved by the administrative or regulatory authority provided the alternate procedure insures equivalent protection and is set forth in writing.
  - C. Durable signs shall be installed at the operator's station and on the outside of the crane, warning that electrocution or serious bodily injury may occur unless a minimum clearance of 10 ft. (3.0m) between the crane or the load being handled and energized power lines. Greater clearances are required because of higher voltage as stated above. These signs shall be revised but not removed when local jurisdiction requires greater clearances.

<b>TABLE 1</b>				
			<u>minimum required clearance</u>	
<u>normal voltage, kV (phase to phase)</u>			<u>ft</u>	<u>(m)</u>
<b><u>when operating near high voltage power lines</u></b>				
over		to 50	10	(3.50)
over	50	to 200	15	(4.6)
over	200	to 350	20	(6.1)
over	350	to 500	25	(7.62)
over	500	to 750	35	(10.67)
over	750	to 1000	45	(13.72)
<b><u>while in transit with no load and boom lowered</u></b>				
over		to 0.75	4	(1.22)
over	0.75	to 50	6	(1.83)
over	50	to 345	10	(3.83)
over	345	to 750	16	(4.87)
over	750	to 1000	20	(6.1)

## **—IMPORTANT— BEFORE OPERATING CRANE**

1. Make sure this manual has been thoroughly read by all crane operating personnel and supervisors.
2. A routine inspection of the crane should be mandatory before each operating day. Any defects should be corrected immediately.
3. At a job site the vehicle should be positioned so that the crane can adequately reach the load within the rated capacity (centerline of rotation to hoist hook).
4. Keep the vehicle as level as possible during operation. **CANNOT EXCEED 15% GRADE.**
5. For electric cranes, **engage emergency brake** and leave ignition on with transmission in neutral (or in park for automatic transmissions). Activate any crane power switches. For Auto Crane units requiring battery and hydraulic operation, **engage emergency brake**, place gear selector in neutral, press clutch, activate PTO, release clutch and after hydraulic fluid is warm, set throttle control to proper engine speed.
6. Always use outriggers from the truck to the ground. Be sure these are firm and adequately positioned. When rotating, **keep load as low to the ground as possible.**
7. Remove the transmitter from cab or storage area. Power transmitter on. Detach hook from dead man. Crane is now ready for operation.
8. Always boom up before rotating so the boom will clear the required boom support.
9. When extending the boom, always maintain clearance between the boom crown and the traveling block or hoist hook.
10. Always observe safe and practical operation to avoid possible accidents. Refer to Safety Tips and Precautions.
11. After completing lifting operations, return the boom to stowed position on the boom support. Avoid unneeded pressure on the boom support.
12. Store transmitter in proper location (in cab or storage area).
13. Return outriggers to stowed position. Make sure they are pinned in place or jacklegs are returned to compartment.
14. Check work area for any tools or equipment not stored.
15. Release throttle control, depress clutch and disengage PTO. Deactivate any crane power switches.
16. Report any unusual occurrence during crane operation that may indicate required maintenance or repair.
17. **NEVER** use two cranes to support a load too large for either crane.

## **OPERATION OF OUTRIGGERS**

### **HYDRAULIC OUTRIGGERS**

1. Shift crane/outrigger control valve to "outrigger" position.
2. Operate the outrigger control valves to position the outriggers.
3. After outriggers are positioned, return crane/outrigger selector to "crane" position.
4. Crane is now ready to operate.

### **MANUAL OUTRIGGERS**

1. Pull lock pins to release jackleg or drop down outrigger and move to outermost lock position.
2. Make sure lock pins are reinstalled properly.
3. Lower outrigger pad to firm ground and adjust foot to take out slack.
4. Crane is now ready to operate.

# RECOMMENDED OPERATING TEMPERATURE RANGE—SMALL EH CRANES

## OIL TEMPERATURE

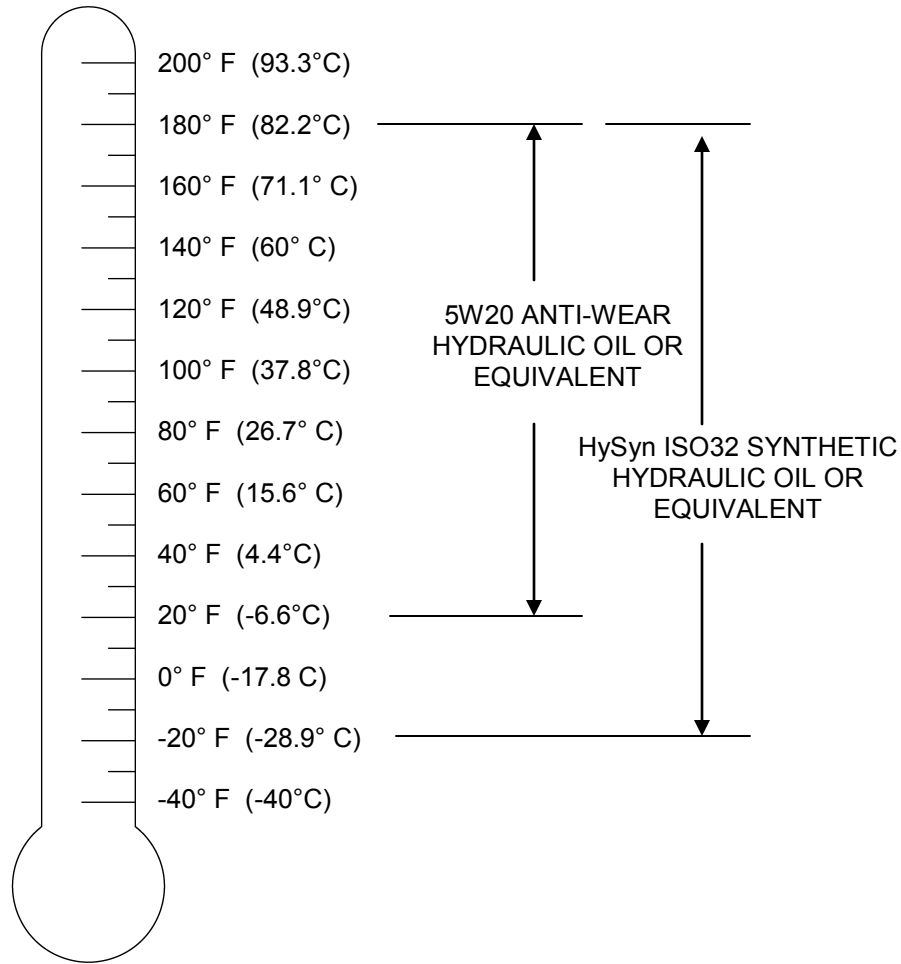

### NOTES

1. In applications where low oil temperatures may exist (below  $-20^{\circ}\text{F}$ ), an external heating system may be required.
2. A symptom of excessively low temperatures is hydraulic motor operation but no fluid flow from tank.

**CAUTION— HYDRAULIC RESERVOIR OIL TEMPERATURE MUST NOT EXCEED  $180^{\circ}\text{F}$  OR DAMAGE TO CRANE MAY OCCUR. THIS MAY AFFECT CRANE WARRANTY**



# CRANE OPERATION

## TRANSMITTER LAYOUT

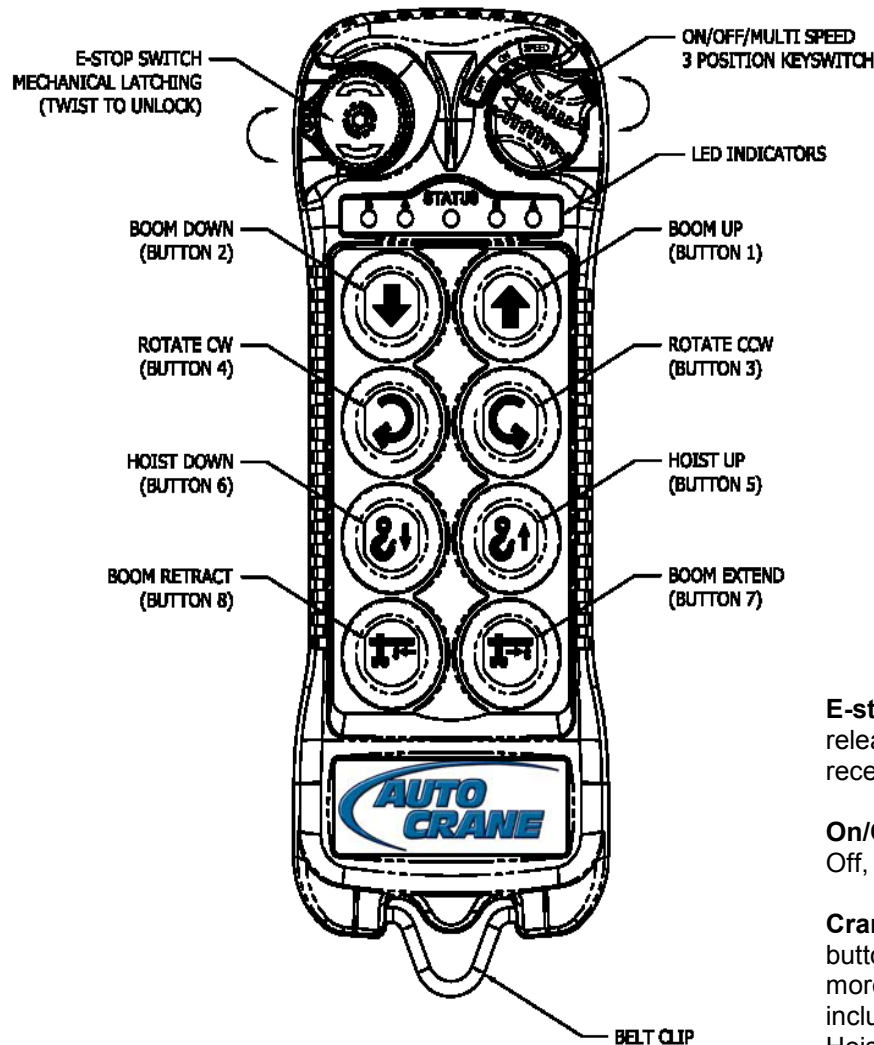

**E-stop Switch**—Push to activate, Twist to release. Shuts down all outputs from receiver.

**On/Off/Multispeed**— Detachable key, On, Off, Multispeed, & Start Switch.

**Crane Controls**—Proportional push button. The function speed increases the more the button is pressed. Functions include Boom Up/Down, Rotate CW-CCW, Hoist Up/Down, Boom Extend, Retract. (NON PROPORTIONAL). PRX-ONLY

**TURNING OFF TRANSMITTER**— Move the On/Off/Multi-speed switch to the “off” position

**TURNING ON TRANSMITTER**— Move the On/Off/Multi-speed switch to the “on” position, then move the On/Off/Multi-speed switch to the “Multi-speed” or “start” position momentarily. The status light should be blinking green when active with no buttons depressed.

**REMOVING KEY**— Move the On/Off/Multi-speed switch to the “off” position, then move the switch counter-clockwise one position past the “off” position. Once the switch is one position past the “off” position then pull out the switch from the transmitter.

# CRANE OPERATION

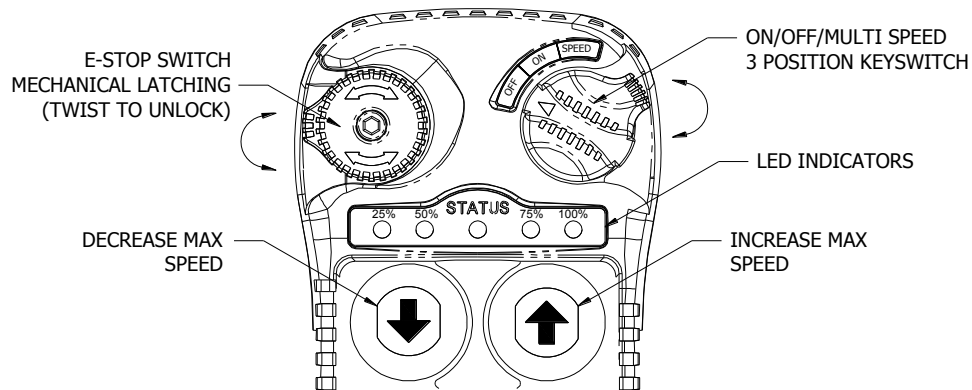

## ACTIVATING E-STOP

Press the E-stop Switch.

Note:

1. When E-stop is active, the transmitter will remain on but will not operate any functions. This includes truck and crane functions.
2. **Activating E-stop will not turn the truck off.**
3. There will be an Error Code on the receiver stating "E-stop active".

## DEACTIVATING E-STOP

1. Twist to release E-stop.
2. Turn transmitter to the "OFF" position.
3. Once all lights turn off. Turn transmitter to the "ON" position.
4. Turn transmitter to the "START"/"SPEED" position and release

Note:

There is very little height difference in a active and inactive E-stop. To verify E-stop switch is deactivated, twist switch to release.

## WAKING UP TRANSMITTER

Turn the transmitter to the "START"/"SPEED" position and release

Note:

The transmitter goes into sleep mode after 5 minutes of inactivity.

## SPEED CONTROL

1. Rotate "ON/OFF/SPEED" switch to the "SPEED" position and hold
2. Press the Boom Up switch in increase max speed or press Boom Down button to decrease. Each time the button is actuated, the max speed increases or decreases to the next 25% range.
3. Release "ON/OFF/SPEED" switch once the desired speed is selected.

Note:

1. Slower speed decreases the max speed and gives more finite control of the proportional push button.
2. Faster speed increases the max speed but give less finite control of the load
3. The LED indicators show the current speed setting of the transmitter.

# CRANE OPERATION

## RECEIVER LAYOUT (FM UNITS ONLY)

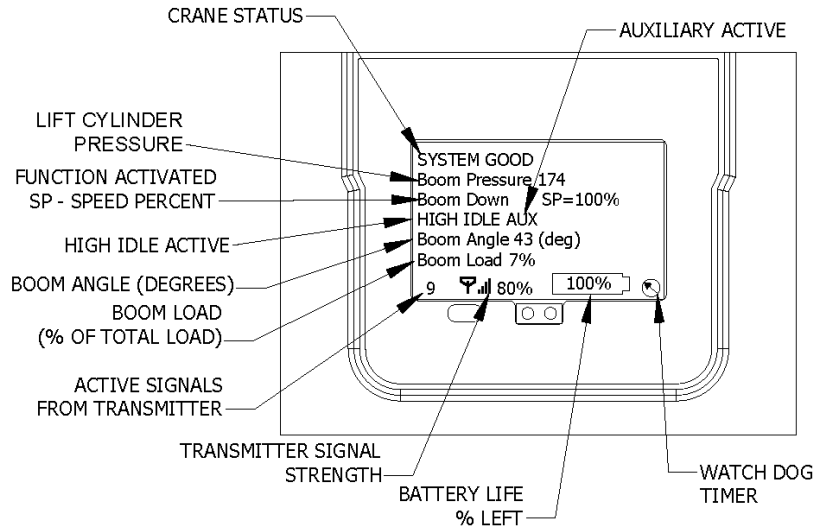

**CRANE STATUS**—shows current status of the crane. If any alarms are occurring they will be displayed here. Otherwise, it will say system good.

**Note: Reference Troubleshooting section for alarm descriptions.**

**LIFT CYLINDER PRESSURE**—Current pressure in the lift cylinder in PSI

**FUNCTION ACTIVATED SP-SPEED PERCENT**—Current function activated and percent of max speed for that particular function.

**Note: If multi-functioning, only last function selected will be displayed.**

**BOOM ANGLE (DEGREES)** - Current boom angle in degrees.

**Note: This value may not match the boom angle decal attached to side of boom since the decal is referenced to the ground not the pedestal.**

**BOOM LOAD**—Current percent of crane capacity used. **Note: Unloaded this value may be higher than 0% due to boom weight beyond the retracted position.**

**ACTIVE SIGNALS FROM TRANSMITTER**—Shows current status of transmitter. 0 means the transmitter is not active. It must be turned on, e-stop deactivated, or taken out of sleep mode. 5-6 means the transmitter is active but no function is currently being selected. Receiver is waiting on a command from the user. 9-10 means the transmitter is sending crane function signals to start operating the crane. The user is sending a command for the crane to operate.

**TRANSMITTER SIGNAL STRENGTH**—Shows the strength of signal coming from transmitter.

**Note: approximate range of transmitter is 300 feet.**

**BATTERY LIFE**—Percent of transmitter battery life remaining

**WATCH DOG TIMER**— Should always be spinning. If timer stops spinning contact your AutoCrane representative

# CRANE OPERATION

## RECEIVER LAYOUT (TETHERED UNITS ONLY)

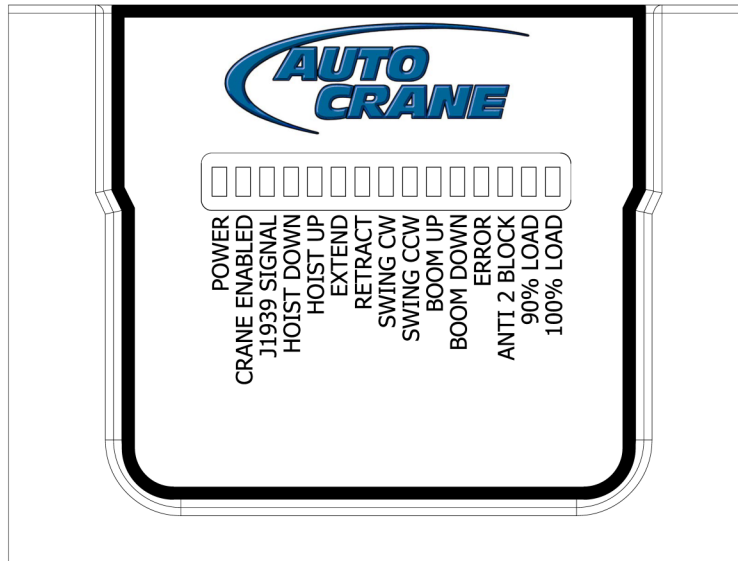

**POWER**—(steady green) turns on with power.

**CRANE ENABLED** — (green 1 pulse/second) Crane enable “Inactive” Need to wake up transmitter before hitting function  
(green 4 pulse/second) Crane enable “Active” Ready for a function to be selected

**J1939 SIGNAL** — (green 4 pulse/second) transmitter is on

**FUNCTIONS (I.E. HOIST UP-BOOM DOWN)** - (green proportional) Activated when function is selected. Blink rate is proportional with function request.

**ERROR** — (red stead) Battery voltage dropped below 9V

**ANTI 2 BLOCK**—(red steady) turns on when Anti-two Block is active

**90% LOAD** — (amber steady) turn on when the crane reaches 90% of rated capacity

**100% LOAD** — (red steady) turns on when the crane reaches 100% of rated capacity (overload situation)

# **INSPECTION REQUIREMENTS**

## **REFERENCE ASME B30.5a AND OSHA 1910.180 FOR COMPLETE INSPECTION REQUIREMENTS**

### **INSPECTION CLASSIFICATION**

1. Initial inspection.  
Prior to initial use, all new, altered, modified or extensively repaired cranes shall be inspected by a designated person to insure compliance with provisions of this standard
2. Regular inspection.  
Inspection procedure for cranes in regular service is divided into two general classifications based upon the intervals at which inspection should be performed. The intervals in turn are dependent upon the nature of the components of the crane and the degree of their exposure to wear, deterioration, or malfunction. The two general classifications are herein designated as "frequent" and "periodic" with respective intervals between inspections as defined below.
  - A. Frequent inspection - daily or before each use
  - B. Periodic inspection - one to twelve-month intervals or as specifically recommended by the manufacturer or qualified person.
7. Inspect electrical wiring and components for malfunctioning, signs of excessive deterioration, dirt and moisture accumulation.
8. Inspect hydraulic system for proper oil level and leaks.
9. Inspect tires for recommended inflation pressure, cuts and loose wheel nuts.
10. Inspect connecting pins and locking device for wear damage and loose retaining bolts.
11. Inspect rope for gross damage, such as listed below, which may be an immediate hazard.
  - A. Distortion such as kinking, crushing, un-stranding, birdcaging, main strand displacement, or core protrusion. Loss of rope diameter in a short length or unevenness of outer strands should be replaced.
  - B. General corrosion.
  - C. Broken or cut strands.
  - D. Use care when inspecting sections of rapid deterioration around flange points, crossover points, and repetitive pickup points on drums.
  - E. Inspect number, distribution, and type of visible broken wires. Reference Rope Maintenance section in the owner's manual.

**DESIGNATED PERSONNEL SHALL  
PERFORM INSPECTIONS ONLY.**

### **FREQUENT INSPECTION**

Inspections should also occur during operation for any deficiencies that might appear between regular inspections. Any deficiencies, such as those listed below, shall be carefully examined and a determination made as to whether they constitute a hazard:

1. Inspect control mechanisms for maladjustment that interferes with proper operation.
2. Inspect control mechanisms for excessive wear of components and contamination by lubricants or other foreign matter.
3. Inspect safety devices for malfunction.
4. Visually inspect all hydraulic hoses, particularly those that flex in normal operation of crane functions.
5. Inspect hooks and latches for deformation, chemical damage, cracks, and wear. Refer to ANSI/ASME B30.10.
6. Inspect for proper rope reeving.

***Continued use of rope depends upon good judgment by a designated person in evaluating remaining strength in a used rope after allowance for deterioration disclosed by inspection. Continued rope operation depends upon this remaining strength.***

### **PERIODIC INSPECTION**

Any deficiencies, such as those listed below, shall be carefully examined and determination made as to whether they constitute a hazard:

1. Inspect for deformed, cracked or corroded members in the crane structure and entire boom.
2. Inspect for loose bolts, particularly mounting bolts.
3. Inspect for cracked or worn sheaves and drums.
4. Inspect for worn, cracked, or distorted parts such as pins, bearings, shafts, gears, rollers and devices.
5. Inspect for excessive wear on brake and clutch system parts and lining.
6. Inspect crane hooks for cracks.

# **INSPECTION REQUIREMENTS**

7. Inspect travel steering, braking, and locking devices for malfunction.
8. Inspect for excessively worn or damaged tires.
9. Inspect hydraulic hose, fittings, and tubing for the following problems:
  - A. Evidence of leakage at the surface of the flexible hose or its junction with metal and coupling.
  - B. Blistering, or abnormal deformation to the outer covering of the hydraulic or pneumatic hose.
  - C. Leakage at threaded or clamped joints that cannot be eliminated by normal tightening or recommended procedures.
  - D. Evidence of excessive abrasion or scrubbing on the outer surface of a hose, rigid tube, or fitting. Means shall be taken to eliminate the interference of elements in contact or otherwise protect the components.
10. Inspect hydraulic pumps and motors for the following problems:
  - A. Loose bolts and fasteners.
  - B. Leaks at joints between sections.
  - C. Shaft seal leaks.
  - D. Unusual noises or vibrations.
  - E. Loss of operating speed.
  - F. Excessive heating of the fluid.
  - G. Loss of pressure.
11. Inspect hydraulic valves for the following problems:
  - A. Cracks in valve housing.
  - B. Improper return of spool to neutral position.
  - C. Leaks at spools or joints.
  - D. Sticking spools.
  - E. Failure of relief valves to attain or maintain correct pressure setting.
  - F. Relief valve pressure shall be checked as specified by the manufacturers.
12. Inspect hydraulic cylinders for the following problems:
  - A. Drifting caused by fluid leaking across piston.
  - B. Rod seals leaking.
  - C. Leaks at welding joints.
  - D. Scored, nicked, or dented cylinder rods.
  - E. Damaged case (barrel).
  - F. Loose or deformed rod eyes or connecting joints.
13. Inspect hydraulic filters for evidence of rubber particles on the filter elements indicating possible hose, "O" ring, or other rubber component deterioration. Metal chips or pieces on the filter may denote failure in pumps, motors, or cylinders. Further inspection will be necessary to determine the origin of the problem before corrective action can be taken.
14. Inspect labels to confirm correct location and legibility. Reference decal layout in this manual for proper location of decals.
15. Rope Inspections need not be at equal calendar intervals and should be more frequent as the rope approaches the end of useful life. A qualified person shall inspect the wire rope based on such factors as:
  - A. Expected rope life as determined by experience on the particular installation or similar installations.
  - B. Severity of environment.
  - C. Percentage of capacity lifts.
  - D. Frequency rates of operation.
  - E. Exposure to shock loads.

This inspection shall cover the entire length of the rope. Only the surface wires need to be inspected and no attempt should be made to open the rope. Any deterioration resulting in appreciable loss of original strength shall be noted and determination made as to whether use of the rope would constitute a hazard. A few notable deterioration points are listed below:

  - A. Reduction of rope diameter below nominal diameter due to loss of core support.
  - B. Internal or external corrosion.
  - C. Wear of outside wires.
  - D. Severely corroded, cracked, bent, worn, or improperly applied connections.

## **CRANES NOT IN REGULAR USE**

A crane, which has been idle for a period of over one month or more, shall be given an inspection conforming to the "initial" and "regular" inspection requirements of this section.

## **INSPECTION RECORDS**

Dated records of periodic inspection should be made on critical items such as brakes, crane hooks, rope, cylinders, and relief pressure valves.

# ***TESTING REQUIREMENTS***

**REFERENCE ASME B30.5a AND OSHA 1910.180 FOR COMPLETE INSPECTION REQUIREMENTS**

**TESTING SHALL BE PERFORMED BY DESIGNATED PERSONNEL ONLY.**

Prior to initial use, all new, altered, modified, or extensively repaired cranes shall be tested for compliance with the operational requirements of this crane.

Test requirements:

1. Test all functions to verify speed and operation.
2. Check that all safety devices are working properly.
3. Confirm operating controls comply with appropriate function labels.
4. Test loads shall not exceed 110% of the manufacturer's load rating.
5. Written reports shall be maintained showing test procedures and confirming the adequacy of repairs

# **GENERAL REPAIRS AND MAINTENANCE**

## **REFERENCE ASME B30.5a AND OSHA 1910.180 FOR COMPLETE MAINTENANCE AND REPAIR REQUIREMENTS**

A preventative maintenance program should be established based on this section and all replacement parts should be obtained from AutoCrane Company. **For replacement parts contact your local authorized distributor.**

### **MAINTENANCE PRECAUTIONS**

1. Place crane where it will cause the least interference with other equipment or operations.
2. Verify all controls are in the "off" position and all operating features secured from inadvertent motion by brakes, pawls, or other means.
3. The means for starting the crane shall be rendered inoperative.
4. The boom should be secured in place before maintenance.
5. Relieve hydraulic oil pressure from all hydraulic circuits before loosening or removing hydraulic components.
6. Warning or "OUT OF ORDER" signs shall be placed on all crane controls.
7. After adjustments and repairs have been made, the crane shall not be returned to service until all guards have been reinstalled, trapped air removed from hydraulic system (if required), safety devices reactivated, and maintenance equipment removed.

### **ADJUSTMENTS AND REPAIRS**

1. Any hazardous conditions disclosed by the inspection requirements shall be corrected before operation of crane is resumed. Only designated personnel shall do adjustments and repairs.
2. Adjustments shall be maintained to assure correct functioning of components, the following are examples:
  - A. Functional operating mechanism.
  - B. Safety devices.
  - C. Control systems.
3. Repairs or replacements shall be provided as needed for operation, the following are examples:
  - A. Critical parts of functional operating mechanisms which are cracked, broken, corroded, bent, or excessively worn.
  - B. Critical parts of the crane structure which are cracked, bent, broken, or excessively corroded.

- C. Crane hooks showing cracks, damage, or corrosion shall be taken out of service. Repairs by welding are not recommended.
4. If bleeding the hydraulic system is required, run each crane function until smooth operation of that particular function is noticeable.

### **LUBRICATION**

All moving parts of the crane, for which lubrication is specified, should be regularly lubricated per the manufacturer's recommendations and procedures. **Reference Lubrication and Maintenance Schedule in this manual.**

### **ROPE REPLACEMENT**

**No precise rules can be given for determination of the exact time for replacement of rope, since many variable factors are involved.**

1. Conditions such as the following shall be reason for questioning continued use of the rope or increasing the frequency of inspection:
  - A. In running ropes, six randomly distributed broken wires in one lay or three broken wires in one strand in one lay.
  - B. One outer wire broken at the contact point with the core of the rope structure and protrudes or loops out of the rope structure. Additional inspection of this section is required.
  - C. Wear of one third of the original diameter of the outside individual wire.
  - D. Kinking, crushing, bird caging, or any other damage resulting in distortion of the rope structure.
  - E. Evidence of any heat damage from any cause.
  - F. Reduction from nominal diameter of more than 1/64 in. (0.4mm) for diameters up to and including 5/16 in. (8 mm), 1/32 in. (0.8 mm) for diameter 3/8 in. (9.5 mm) to and including 1/2 in. (13 mm), 3/64 in. (1.2 mm) for diameter 9/16 in. (14.5 mm) to and including 3/4 in. (19 mm), 1/16 in. (1.6 mm) for diameter 7/8 in. (22 mm) to and including 1 1/8 in. (29 mm), 3/32 in. (2.4 mm) for diameters 1 1/4 in. (32 mm) to and including 1 1/2 in. (38 mm).
  - G. In standing ropes, more than two broken wires in one lay in sections beyond end connections or more than one broken wire at an end connection.



# **GENERAL REPAIRS AND MAINTENANCE**

2. Replacement rope shall have a strength rating at least as great as the original rope furnished or recommended by AutoCrane. A rope manufacturer, AutoCrane, or a qualified person shall specify any deviation from the original size, grade, or construction.

## **ROPE MAINTENANCE**

1. Rope should be stored to prevent damage or deterioration.
2. Unreeling or uncoiling of rope shall be done as recommended by the rope manufacturer and with care to avoid kinking or inducing twist.
3. Before cutting a rope, seizing shall be placed on each side of the place where the rope is to be cut to prevent unlaying of the strands. On pre-formed rope, one seizing on each side of the cut is required. On non-preformed ropes of 7/8 in. (22 mm) diameter or smaller, two seizings on each side of the cut are required, and for non-preformed rope 1 in. (25 mm) diameter or larger, three seizings on each side of the cut are required.

4. During installation care should be exercised to avoid dragging of the rope in the dirt or around objects that will scrape, nick crush or induce sharp bends in it.
5. Rope should be maintained in a well-lubricated condition. It is important that lubricant applied as a part of a maintenance program shall be compatible with the original lubricant and to this end the rope manufacturer should be consulted. Lubricant applied shall be the type that does not hinder visual inspection. Those sections of rope that are located over sheaves or otherwise hidden during inspection and maintenance procedures require special attention when lubricating rope. The object of rope lubrication is to reduce internal friction and to prevent corrosion.
6. When an operating rope shows greater wear or well-defined localized areas than on the remainder of the rope, rope life can be extended in some cases by shifting the wear to different areas of the rope.

# MAINTENANCE OF BATTERIES

Maintenance of Auto Crane unit batteries differs very little from the generally prescribed maintenance of any lead acid battery. All batteries must be kept properly charged, properly filled with water, and relatively clean.

## **Keep Properly Charged**

Many things affect the proper charge to a battery, such as:

1. Regulator settings.
2. Proper tightness of belts on the alternator or generator.
3. Good, clean connections of all cables and wires at the following places:
  - a. Battery.
  - b. Regulator.
  - c. Starting motor.
  - d. Alternator or generator.
  - e. Ground connections (most important).

It is of extreme importance to keep the battery as fully charged as possible without overcharging, especially when vehicles are left outside for extended periods in extremely cold climates. A battery can freeze. Freezing points for various specific gravities of acid are as follows:

Specific Gravity (Corrected to 80°F)	Freezing Temp. Degrees F.
1.280	-90°F
1.250	-62°F
1.200	-16°F
1.150	5°F
1.100	19°F

As shown, a half-charged battery (about 1.100 specific gravity) cannot stand for any length of time at 20°F or it will freeze.

The main reason for keeping the battery as fully charged as possible without over-charging is to insure that power is available even though the vehicle has been standing for some time.

## **Keep Properly Filled with Water**

The battery should *always* be properly filled with water. If the electrolyte level is allowed to fall below the top of the plates, the results become threefold:

1. The exposed portion of the plate will become sulfated.
2. The portion of the plate exposed is not usable.
3. That portion of the acid remaining becomes more concentrated and may cause more rapid deterioration of the remaining parts of the battery.

## **Keep A Relatively Clean Battery**

The battery should be kept clean. Batteries filled with acid and which are not in use self-discharge to a limited degree because of the nature of the materials within the battery. If dirt is allowed to collect on the top of the battery (and this dirt absorbs moisture) and electrical path can be set up between the various terminals of the battery and the ground. Once such a path has been established, the self-discharge of the battery is accelerated. This also accelerates corrosion of the battery cables at the terminals.

## **Periodic Maintenance is Needed**

A definite program of periodic maintenance of all batteries should be conducted on a regular basis. Periodic maintenance includes:

1. Checking belts for tightness on the charging equipment.
2. Checking battery electrolyte levels.
3. Checking cables for good connections.
4. Cleaning where corrosion is apparent.

When corrosion is cleaned off, the cable terminals and battery terminals should be coated with a light coating of petroleum jelly before they are replaced. When terminals are cleaned, the top of the battery should be cleaned with a mild solution of soda water.

## **Low Maintenance Batteries**

### **(Maintenance Free)**

**Low maintenance batteries should not be used on AutoCrane Cranes or trucks equipped with AutoCrane Cranes. The batteries are not designed for "deep" discharge.**

# ***MAINTENANCE OF BATTERIES***

## **Testing Your Battery**

If the condition of the battery is in question, it should be removed from the vehicle, taken to the shop, and allowed to reach room temperature. It should then be recharged until specific gravity readings taken at one-half hour intervals. If the specific gravity readings are fairly uniform, the battery should be checked with a high rate tester. Use the tester in accordance with the manufacturer's instructions. The high rate tester is the best method to test a questionable battery.

If, after charging, it is noted that the specific gravity reading of one cell is 30 points less than any of the other cells, it may be assumed that the cell is bad and that the battery should be replaced. If all cells are uniform but not up to full charge, a low rate of charge should be attempted for an extended time. This usually will recover a badly sulfated battery.

## **Replacing a Battery**

If it is necessary to replace a battery, and a dry charge battery is used, the following procedure applies:

1. Fill the battery with electrolyte of the proper specific gravity.
2. Place the battery on charge according to the manufacturer's instructions.

It is essential that the second step above be followed to ensure that the battery going on the vehicle is fully charged.

It is also very important that the battery hold-downs be checked periodically to insure that the batteries are properly positioned to avoid vibration problems, breakage of cables or terminals. Care must be taken to avoid cracking or breaking containers or covers by tightening hold-down fixtures excessively. They also must not be so loose that breakage results from a hold-down that is too loose.

# 3203EH

## **LUBRICATION & MAINTENANCE SCHEDULE**

SERVICE PERFORMED	DAY	WKLY	3 MOS	6 MOS	YEAR	NOTES
LOAD HOOK	X					INSPECT HOOK & LATCH FOR DEFORMATION, CRACKS, & CORROSION
CABLE DRUM	X					MAKE SURE CABLE IS WOUND EVENLY ON DRUM
HOIST / BOOM CABLE	X					CHECK FOR FLATTENING, KINKS, & BROKEN STRANDS, SEE MANUAL
HYD. HOSES	X					VISUAL INSPECTION
HYD. FLUID	X					CHECK FLUID LEVEL
MOTOR CONNECTIONS		X				CHECK TERMINALS FOR TIGHT CONNECTIONS
POWER CABLE			X			CHECK INSULATION FOR DAMAGE OR DETERIORATION
PIN RETAINING BOLTS	X					CHECK TORQUE TO 23 FT-LBS (GRADE 5), 35 FT-LBS (GRADE 8) AS REQUIRED
MOUNTING BOLTS		X				CHECK TORQUE: TO 335 FT-LBS FOR 3/4-16
ROTATION RING GEAR		X				LUBE WITH MOBILETAC LL, OR LUBRIPLATE P/N 15263, OR EQUAL
SHEAVE BEARINGS		X				SEALED BEARING, REPLACE IF ROUGH OR LOOSE
ALL OTHER BOLTS		X				CHECK TIGHTEN AS REQUIRED
LIFT CYLINDER BEARINGS			X			GREASE WITH MOBILEPLEX EP-2 OR EQUIVALENT @ ZERKS
ROTATION BEARING			X			GREASE WITH MOBILEPLEX EP-2 OR EQUIVALENT @ ZERKS
ROTATION BEARING BOLTS			X			CHECK TORQUE TO 170 FT-LBS (HEX HEAD)
HOIST GEARBOX				X		WORM GEAR-EP GEAR LUBE SAE 80-90
ROTATION WORM BEARING				X		GREASE WITH MOBILEPLEX EP-2 OR EQUIVALENT @ ZERKS
HYDRAULIC FLUID					X	DRAIN, FLUSH, AND REFILL WITH MOBILE DTE 13 HYD. OIL
BOOM SLIDE PADS	PADS GREASED WHEN REPLACED					
FOR ADDITIONAL INFORMATION SEE:	1) OWNER'S MANUAL 2) OSHA SECTION 1910.180 3) ANSI B30.5-1989					

**CAUTION:** Routine maintenance ensures trouble-free operation and protects your investment. All warranties are void if maintenance is neglected.

# **3203EH PR/PRX**

## ***LUBRICATION & MAINTENANCE SCHEDULE***

### **NOTES:**

1. Use only authorized parts. Any damage or malfunction caused by the use of unauthorized parts is not covered by Warranty or Product Liability.
2. Once a bolt has been torqued to its rated capacity and then removed; the bolt should be replaced with a new one.
3. Auto Crane Company recommends that this crane be serviced per “Crane Inspection Log” P/N 999978. These logs should be filled in at the intervals noted and kept as a permanent record. Additional copies are available from your local distributor.



# 3203EH

## SAFETY DECAL SECTION

PART NO.:	040579000
DECAL:	OPERATING INSTRUCTIONS
FUNCTION:	To inform the operator of the proper procedure to follow for safe operation of the crane.
USED ON:	All Cranes
QUANTITY:	1
PLACEMENT:	Right side plate

**⚠ CAUTION**

1. INSPECT VEHICLE AND CRANE INCLUDING OPERATION, PRIOR TO USE DAILY.
2. DO NOT USE THIS EQUIPMENT EXCEPT ON SOLID, LEVEL SURFACE WITH OUTRIGGERS PROPERLY EXTENDED AND CRANE MOUNTED ON FACTORY-RECOMMENDED TRUCK.
3. BEFORE OPERATING THE CRANE, REFER TO MAXIMUM LOAD (CAPACITY) CHART ON CRANE FOR OPERATING (LOAD) LIMITATIONS.
4. OPERATE ALL CONTROLS SLOWLY AND SMOOTHLY.
5. KEEP LOAD UNDER BOOM TIP. DO NOT SIDE LOAD BOOM OR DRAG LOADS. AVOID FREE SWINGING LOADS.
6. DO NOT OPERATE, WALK OR STAND BENEATH BOOM OR A SUSPENDED LOAD.
7. KEEP AT LEAST 5 WRAPS OF LOADLINE ON HOIST DRUM.
8. FOR TRAVELING, BOOM AND OUTRIGGERS MUST BE IN THE STOWED POSITION.
9. ALL REMOVABLE PENDANTS MUST BE STORED IN CAB OR TOOL COMPARTMENT WHEN CRANE IS NOT IN USE.

P/N 040579

PART NO.:	040580000
DECAL:	OPERATING TRAINING
FUNCTION:	To inform the operator of the need to receive proper training before using the crane.
USED ON:	All Cranes
QUANTITY:	1
PLACEMENT:	Right side plate

**⚠ DANGER**

AN UNTRAINED OPERATOR  
SUBJECTS HIMSELF AND  
OTHERS TO

**DEATH OR SERIOUS INJURY**

- 1.) YOU MUST HAVE BEEN TRAINED IN THE OPERATION OF THIS CRANE, AND
- 2.) YOU MUST KNOW AND FOLLOW THE SAFETY AND OPERATING RECOMMENDATIONS CONTAINED IN THE MANUFACTURER'S MANUAL, YOUR EMPLOYER'S WORK RULES AND APPLICABLE GOVERNMENT REGULATIONS.

P/N 040580

PART NO.:	040632000
DECAL:	TAMPERING WITH OVERLOAD DEVICE
FUNCTION:	To inform the operator that tampering with the overload device may cause a unit failure or possible personal injury.
USED ON:	All Cranes equipped with a load sensor
QUANTITY:	1
PLACEMENT:	Right side of valve sensor.

**⚠ WARNING**

TAMPERING WITH OVERLOAD DEVICE VOIDS WARRANTY. OVERLOADED CRANE MAY HYDRAULICALLY RELEASE AND LET LOAD DOWN TO GROUND.

OVERLOAD PROTECTION DEVICE CANNOT FUNCTION WITH BOOM BELOW HORIZONTAL (0°). HOIST UP, BOOM DOWN, AND EXTEND OUT WILL BE INOPERATIVE WHEN CRANE IS IN OVERLOAD CONDITION.

P/N 040632

# 3203EH

## SAFETY DECAL SECTION

PART NO.:	040529000
DECAL:	ELECTROCUTION HAZARD
FUNCTION:	To inform the operator of the hazard involved with contacting electrical power lines with crane boom.
USED ON:	All Cranes
QUANTITY:	2
PLACEMENT:	Both sides of end of lower boom

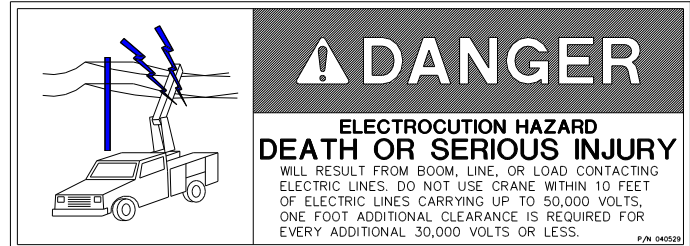

PART NO.:	040517000
DECAL:	STAY CLEAR OF BOOM
FUNCTION:	To inform the operator of the hazard of proximity or contact with the crane boom during operation.
USED ON:	All Cranes
QUANTITY:	2
PLACEMENT:	Both sides of crown

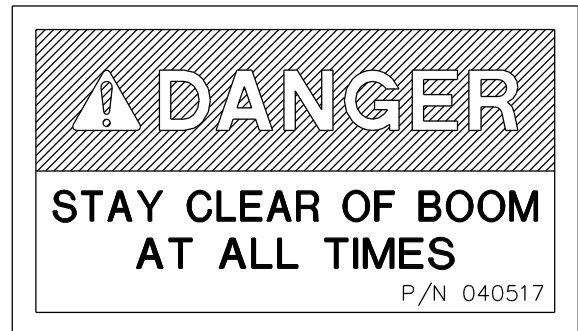

PART NO.:	040518000
DECAL:	STAY CLEAR OF LOAD
FUNCTION:	To inform the operator of the hazard of proximity or contact with the crane load during operation.
USED ON:	All Cranes
QUANTITY:	2
PLACEMENT:	Both sides of traveling block

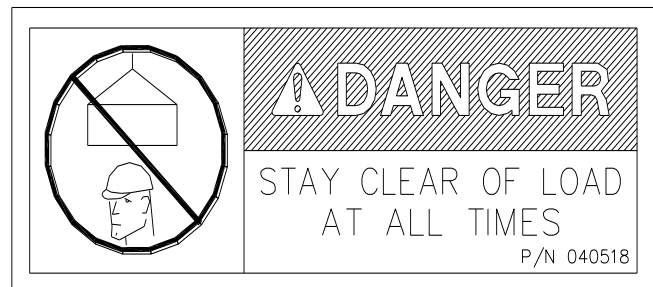



# 3203EH

## SAFETY DECAL SECTION

PART NO.:	040587000	USED ON:	All cranes equipped with a load sensor.
DECAL:	LOAD SENSOR, DON'T TAMPER	QUANTITY:	2
FUNCTION:	To inform the operator that the load sensor is pre-set and that tampering with the sensor may cause potentially hazardous situation.	PLACEMENT:	Both sides of the lift cylinder near the load sensor
USED ON:	All cranes equipped with a load sensor.		
QUANTITY:	1		
PLACEMENT:	On the lift cylinder near the load sensor		

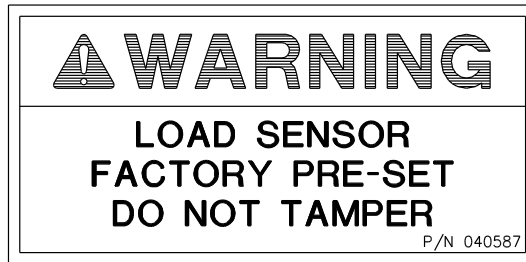

PART NO.:	040519000	USED ON:	All cranes.
DECAL:	SCISSORS POINT	QUANTITY:	2
FUNCTION:	To inform the operator of possible danger at scissors point on crane.	PLACEMENT:	Both sides of the lift cylinder

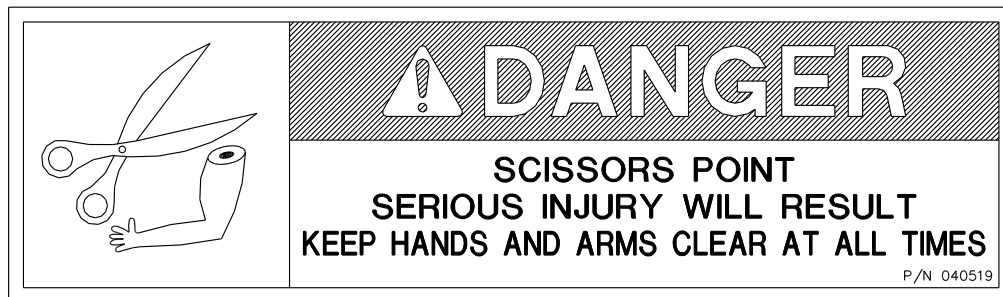

# 3203EH

## ***SAFETY DECAL SECTION***

PART NO.:	460169000	USED ON:	All Cranes equipped with FM controls.
DECAL:	REMOTE CONTROL	QUANTITY:	1
FUNCTION:	To inform the operator of failure to follow the safety precautions may result in equipment failure or serious personal injury.	PLACEMENT:	FRONT OF POWER UNIT



## **WARNING**

### **REMOTE CONTROL SAFETY PRECAUTIONS**

READ THE OPERATOR'S MANUAL before using the Remote Control System. Failure to follow the safety precautions may result in equipment failure or serious personal injury.

MAKE SURE MACHINERY AND SURROUNDING AREA IS CLEAR BEFORE OPERATING REMOTE CONTROL SYSTEM. Do not activate the Remote Control System unless it is safe to do so.

TURN OFF THE RECEIVER POWER BEFORE WORKING ON THE MACHINE. Always disconnect the Remote Control System before doing any maintenance to prevent accidental operation of the machine.

DO NOT MODIFY EQUIPMENT WITHOUT WRITTEN APPROVAL FROM THE MANUFACTURER.

### **CARE**

KEEP DRY. Do not clean the Transmitter / Receiver under high pressure. If water or other liquids get inside the Transmitter battery or Receiver compartment, immediately dry the unit. Remove the case and let the unit air dry.

Clean the unit after operation using a damp cloth to remove any mud, dirt, concrete, etc. from the unit and prevent clogging of buttons, switches, etc.

### **MAINTENANCE / WELDING**

DISCONNECT THE RECEIVER BEFORE WELDING ON THIS MACHINE. Failure to disconnect will result in the destruction of the Receiver.

460169000 A

# 3203EH DECAL LAYOUT

## P/N: 320991300

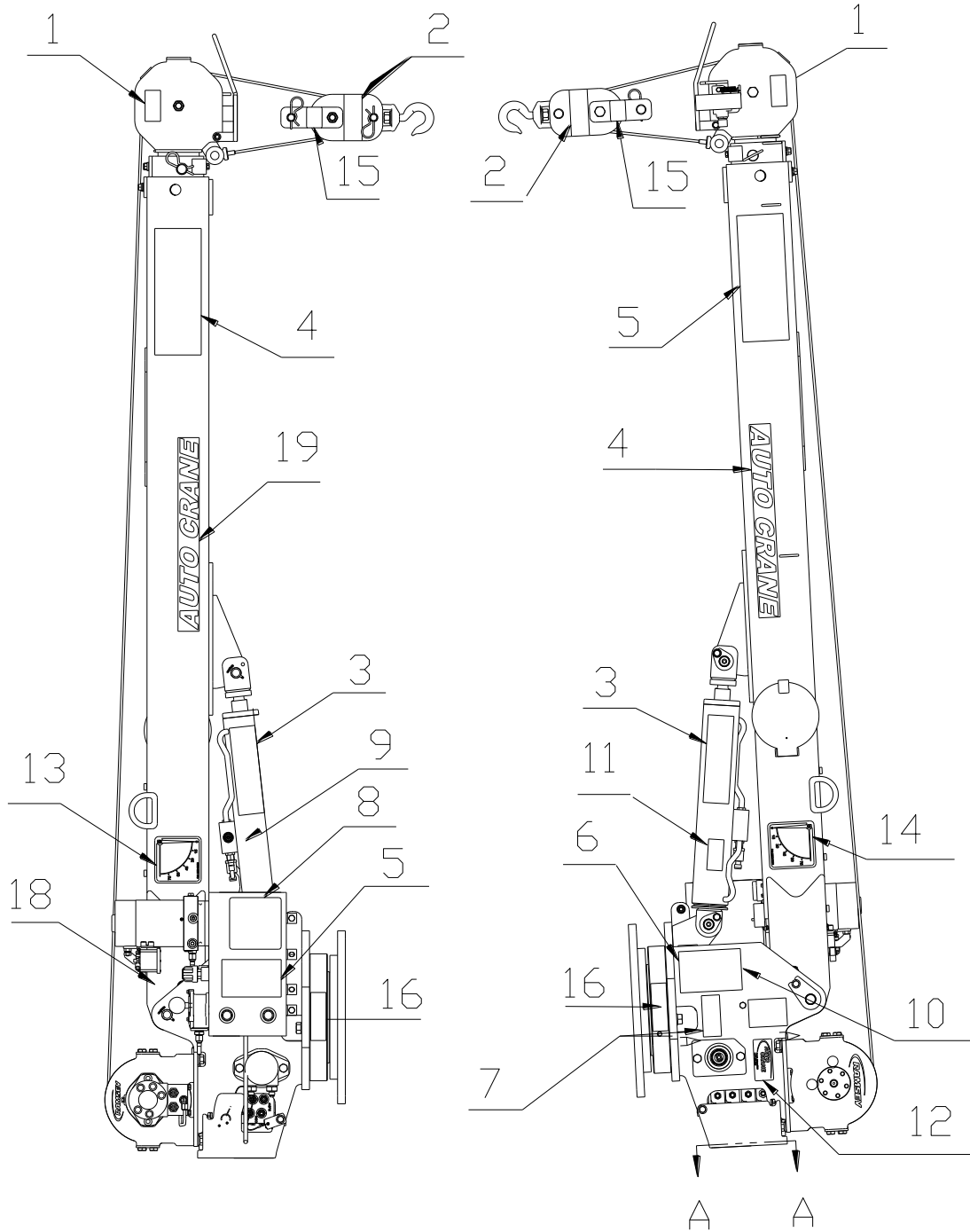

# 3203EH DECAL LAYOUT

## P/N: 320991300

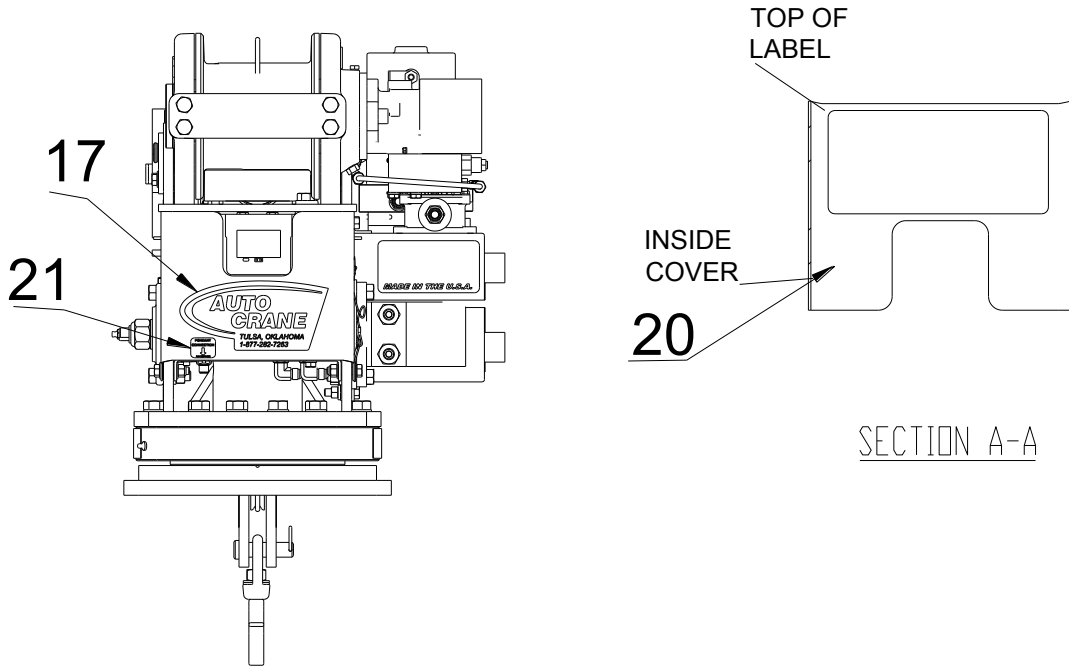

ITEM NO.	QTY	PART NUMBER	DESCRIPTION
1	2	405170000	DECAL STAY CLEAR OF BOOM
2	2	405180000	DECAL STAY CLEAR OF LOAD
3	2	405190000	DECAL DANGER SCISSOR POINT
4	2	405290000	DECAL DANGER "ELECTROCUTION HAZARD" POWER LINE
5	1	405790000	DECAL OPERATION INSTRUCTIONS
6	1	405800000	DECAL TRAINED OPERATOR
7	1	330622000	DECAL SERIAL NO
8	1	320988005	DECAL 3203 LOAD CHART
9	1	460169000	DECAL WARNING, REMOTE CONTROL
10	1	406320000	DECAL WARNING - OVERLOAD
11	1	405870000	DECAL WARNING LOAD SENSOR
12	1	406190010	DECAL AUTO CRANE LOGO
13	1	320318000	DECAL ANGLE INDICATOR CS
14	1	320318001	DECAL ANGLE INDICATOR SS
15	2	320433100	DECAL, TRAVELING BLOCK 3203
16	2	320918000	DECAL 3203 HORIZONTAL
17	1	360034000	DECAL AUTO CRANE LOGO
18	1	408240000	DECAL, AMERICAN FLAG, MADE IN THE U.S.A.
19	2	600047000	DECAL AUTO CRANE
20	1	320991301	DECAL, MAN OVERRIDE NEXSTAR SMALL EH
21	1	320991302	DECAL, PENDANT CONNECTION

# 3203EH GENERAL DIMENSIONS

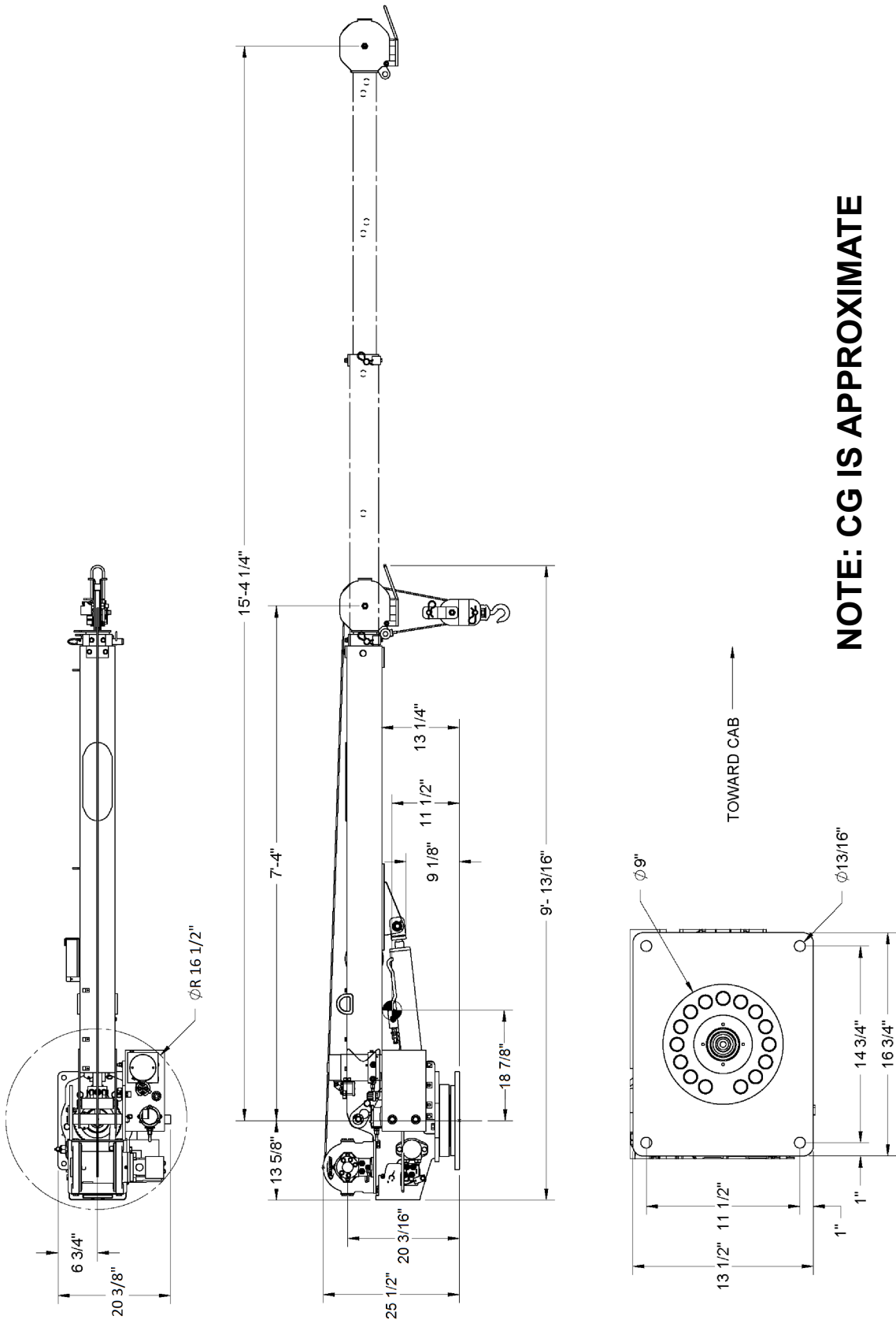

**NOTE: CG IS APPROXIMATE**

# 3203EH MOUNTING AND INSTALLATION

1. Check to make sure the following items are with your crane. Please note the different, model specific, quantities.

ITEM NO.	QTY	PART NUMBER	DESCRIPTION
1	1	404223010	CABLE, POWER HEAVY-DUTY 25FT LG
2	1	404218000	TWECO CABLE ASSY, W/ MASTER SWITCH
3	1	320433000	TRAVELING BLOCK ASSEMBLY
4	6	838000000	CLIP, CABLE #838
5	4	404226000	SCR HX HD 3/4-16UNF x 3 LG GR 8
6	4	404227000	NUT HX 3/4-16UNF, GR 8
7	4	221020000	WASHER FL 3/4
8	4	221010000	WASHER SP LK 3/4
9	1	320988005	DECAL 3203 LOAD CHART
10	1	320991031	MANUAL, OWNERS 3203EH NEXSTAR
11	2	202000000	WASHER SP LK 1/4
12	2	560400000	SCREW HX HD 1/4-20UNC X 1 LG
13	2	203000000	WASHER FL 1/4
14	1	366823266	TRANSMITTER, 8 BUTTON FULL PROP. FM
	1	320991266	TRANSMITTER, 6 BUTTON FULL PROP. FM
	1	366823940	TRANSMITTER, 8 BUTTON FULLY PROP W/CABLE TETHERED
	1	366823945	TRANSMITTER, 6 BUTTON FULLY PROP W/CABLE TETHERED

**NOTES:**

366823266 SHIPS WITH ALL FM PRX UNITS,  
 366823940 SHIPS WITH ALL HW PRX UNITS,  
 366823945 SHIPS WITH ALL HW PR UNITS,  
 320991266 SHIPS WITH ALL FM PR UNITS

2. Vehicle should meet minimum GVW Rating of 10,500 pounds (does not include bodies or accessories).
3. Make sure mounting surface is properly reinforced to withstand 8,800 ft-lb capacity loading of crane and that outriggers are used to provide total stability for the truck.
4. A 9" dia. Hole should be cut out of mounting location (centered with mounting bolts) for access. Reference general dimensions for bolt pattern.
5. Make sure the mounting bolts are 3/4"-16UNF Grade 8. Torque bolts to 335 ft-lbs (dry).
6. When crane is not in operation, a boom support should always be used and the traveling block should be connected to the hook loop.
7. See the following pages for additional electrical installation.
8. Load test the crane to ensure proper functioning and truck stability.
9. Make certain the owner's manual is delivered to the customer.
10. For additional help: call the service department at the Auto Crane Company.  
 (918) 836-0463 (Tulsa, Oklahoma).

## **WARNING**

**FEDERAL LAW** (49 CFR PART 571) REQUIRES THAT THE FINAL STAGE MANUFACTURER OF A VEHICLE CERTIFY THAT THE BEHICLE COMPLIES WITH ALL APPLICABLE FEDERAL REGULATIONS. ANY MODIFICATIONS PERFORMED ON THE VEHICLE PRIOR TO THE FINAL STAGE ARE ALSO CONSIDERED INTERMEDIATE STAGE MANUFACTURING AND MUST BE CERTIFIED AS TO COMPLIANCE. THE INSTALLER OF THIS CRANE AND BODY IS CONSIDERED ONE OF THE MANUFACTURERS OF THE VEHICLE. AS SUCH A MANUFACTURER, THE INSTALLER IS RESPONSIBLE FOR COMPLIANCE WITH ALL APPLICABLE FEDERAL AND STATE REGULATIONS, AND IS REQUIRED TO CERTIFY THAT THE VEHICLE IS IN COMPLIANCE.

**IT IS THE FURTHER RESPONSIBILITY** OF THE INSTALLER OF THE CRANE TO COMPLY WITH THE **OSHA TRUCK CRANE STABILITY REQUIREMENTS** AS SPECIFIED BY 29 CFR PART 1910.180 (C) (1).

# 3203EH

## MOUNTING AND INSTALLATION

### **WARNING!**

FAILURE TO CORRECTLY PLUMB AND WIRE CRANE CAN CAUSE INADVERTENT OPERATION AND DAMAGE TO CRANE AND/OR PERSONNEL!

### **Ground Cable Attachment**

1. Attach ground wire (404223020) to bottom of the crane.
2. Run the ground wire down through the crane box.
3. Locate cable so that it will be protected and avoid sharp edges.
4. Attach ground from crane to frame.

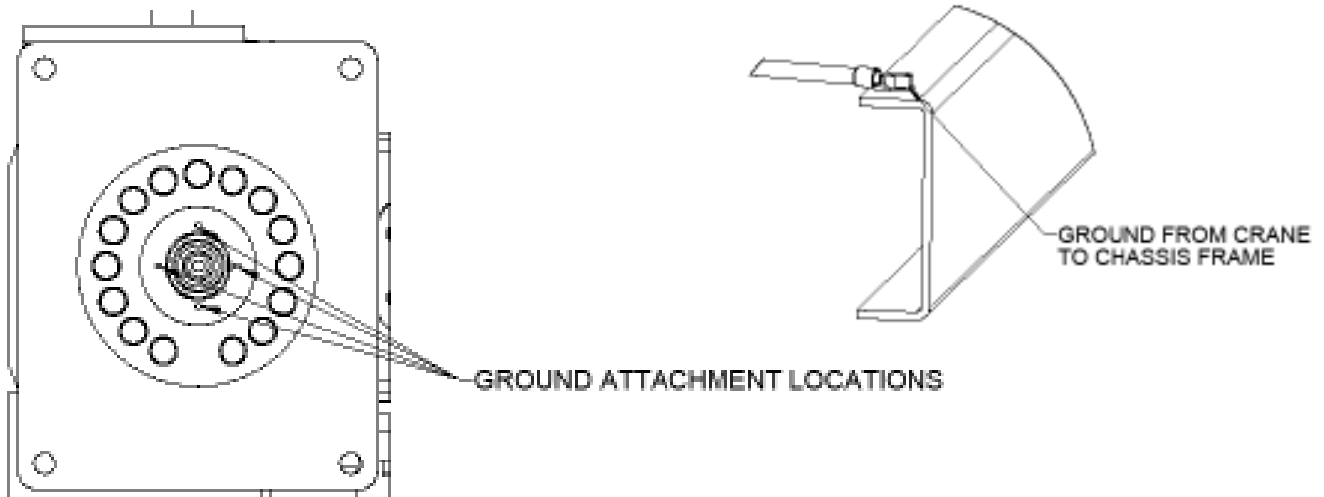

# ***NOTES***



# 3203EH GENERAL ASSEMBLY P/N 320991XXX

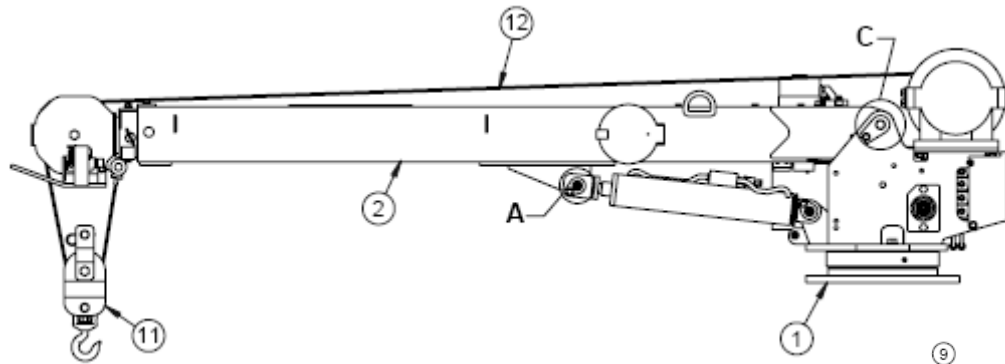

## COMMON PARTS

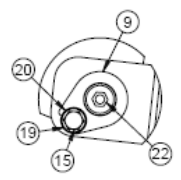

DETAIL A

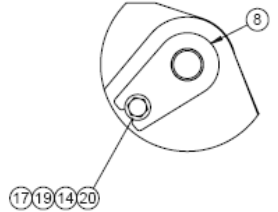

DETAIL C

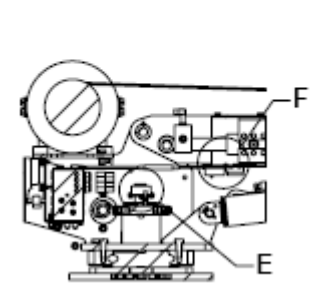
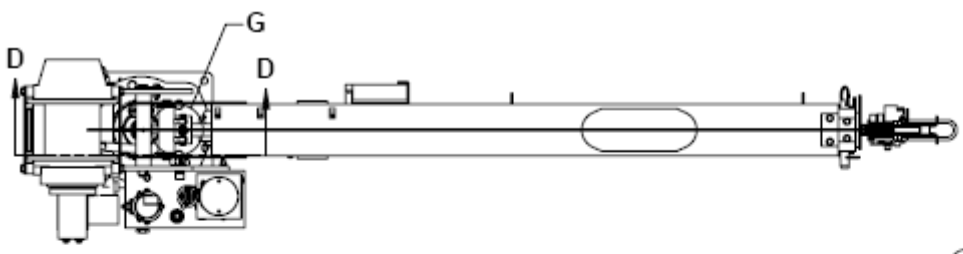

SECTION D-D

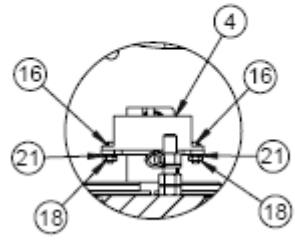

DETAIL E

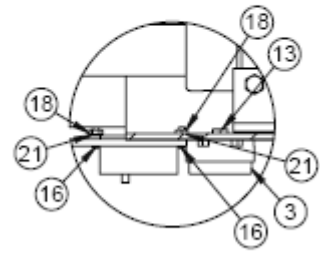

DETAIL F

## FM COMPONENTS

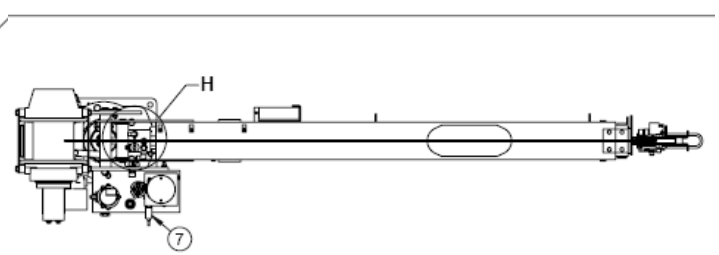

## PRFX COMPONENTS

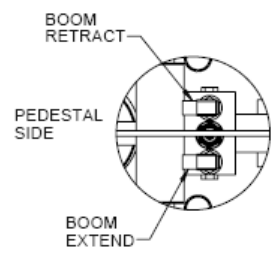

DETAIL G

PRX HOISING DETAIL

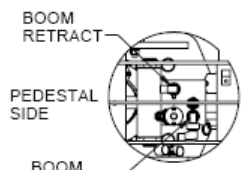

DETAIL H

# 3203EH GENERAL ASSEMBLY

## P/N 320991XXX

12	1	1	1	1	1	1	320338	CABLE
13	1	-	1	-	1	-	5901	SCREW HX HD 1/4-20UNC X 1/2 LG
14	1	1	1	1	1	1	9109000	SCREW HX HD 3/8-16UNC X 1 1/2 LG
15	1	1	1	1	1	1	330371	SCREW HX HD 3/8-16UNC X 1 LG GR8
16	4	-	4	-	4	-	1302000	SCREW RD HD #8-32UNC X 7/8 LG
17	1	1	1	1	1	1	330372	NUT HX 3/8-16UNC
18	4	-	4	-	4	-	15500000	NUT HX #8-32UNC CP
19	2	2	2	2	2	2	21100	WASHER SP LK 3/8
20	2	2	2	2	2	2	21200	WASHER FL 3/8
21	4	-	4	-	4	-	19700	WASHER SP LK #8
22	1	1	1	1	1	1	239300	ZERK, GREASE
23	1	1	1	1	1	1	320991300	DECAL LAYOUT, 3203EH NEXSTAR
24	1	1	1	1	1	1	320991030	KIT, SHIP 3203EH NEXSTAR

# 3203EH PEDESTAL ASSEMBLY P/N 3209912XX

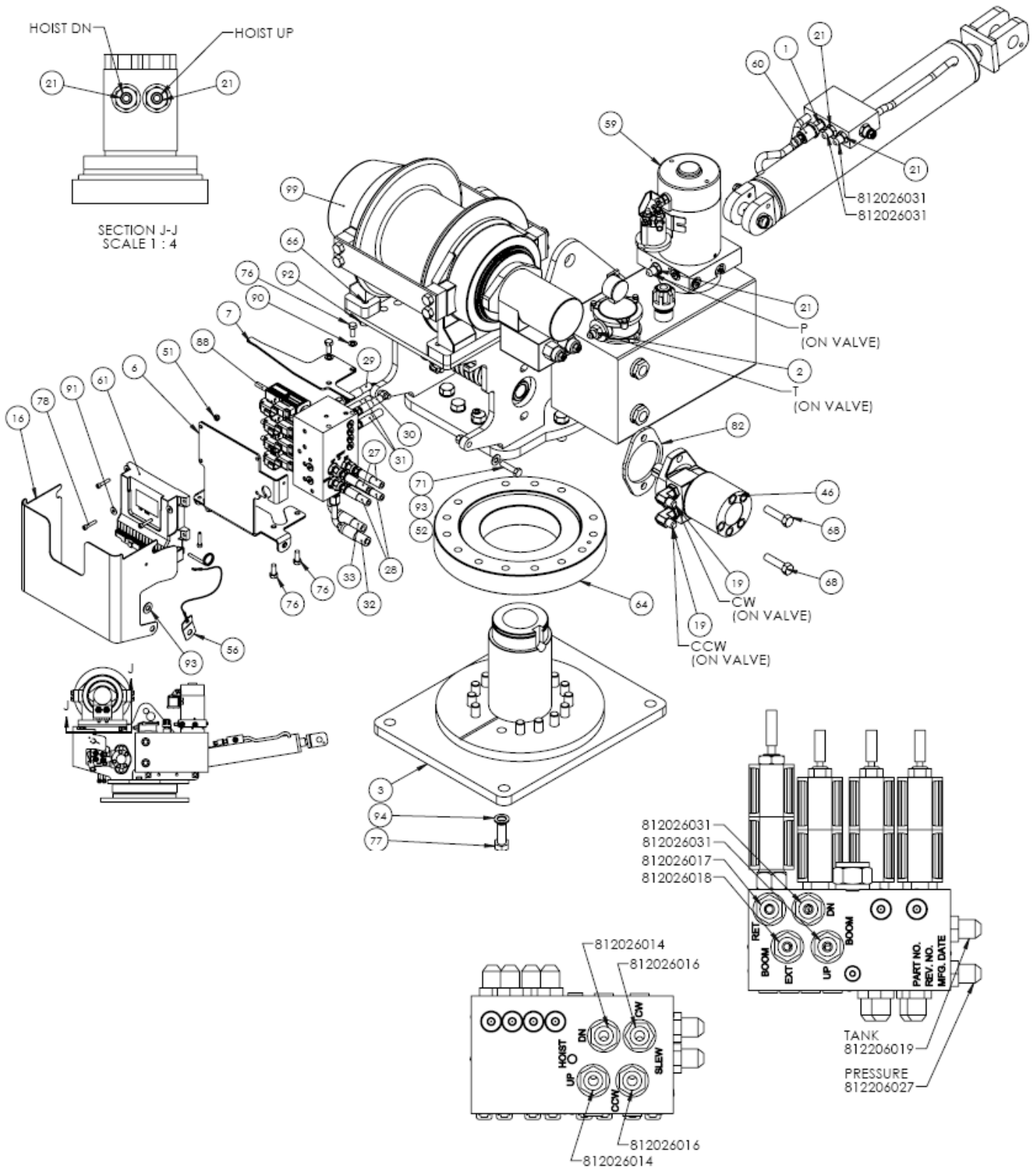

# 3203EH PEDESTAL ASSEMBLY P/N 3209912XX

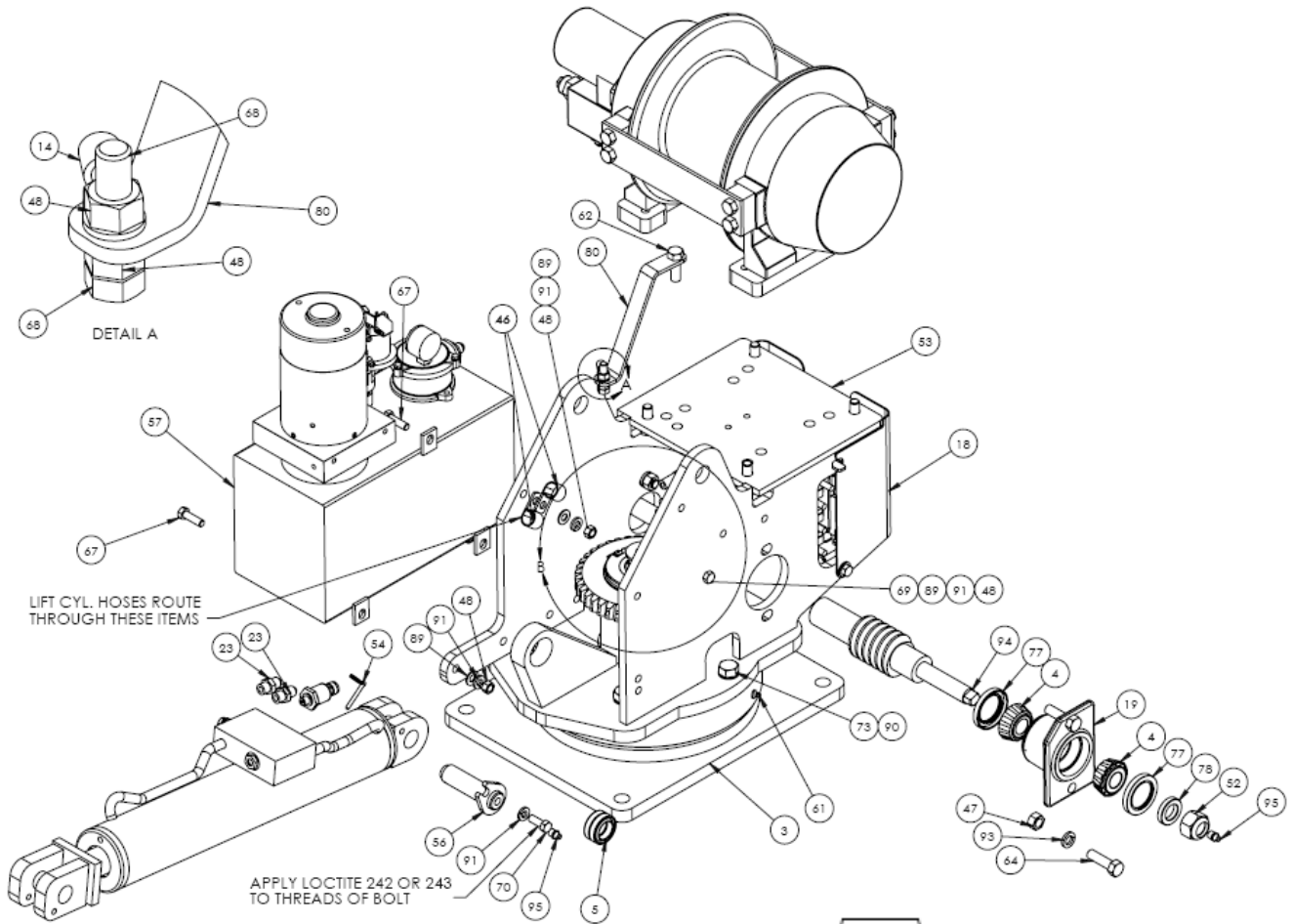

USE CAULK TO FILL HOLE AROUND POWER CABLE IN TWECO BRACKET

APPLY THIN LAYER OF GREASE TO WORM GEAR

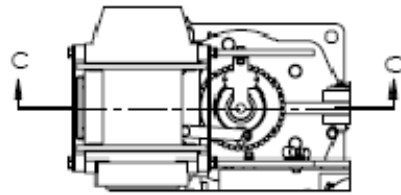
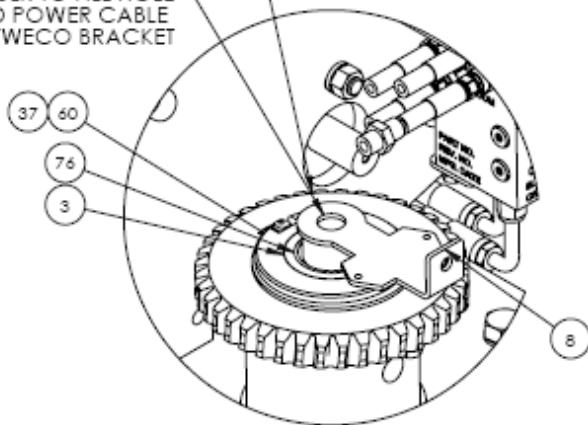

CLAMP POWER CABLE INTO TWECO BRACKET

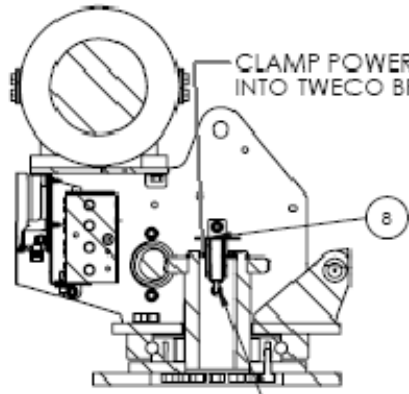

# 3203EH PEDESTAL ASSEMBLY

## P/N 3209912XX

ITEM NO.	-201 PRX-FM	-202 PRX-TH	-203 PR-FM	-204 PR-TH	PART NUMBER	DESCRIPTION
1	1	-	1	-	369611000	ADAPTER, STR -6 ORM/ -4 ORF
2	1	1	1	1	202756000	ADAPTER, STRAIGHT 8SAE(M)-6JIC(M)
3	1	1	1	1	320991230	BASE WLDMNT, 3203/4004
4	2	2	2	2	330485	BEARING, CONE
5	1	1	1	1	320858000	BEARING, SPHERICAL 1.00 ID
6	1	1	1	1	320991223	BRACKET, LOWER VALVE & RECEIVER, 3203/4004 EH
7	1	1	1	1	320991222	BRACKET, UPPER VALVE 3203/4004 EH
8	-	-	-	-	320991228	BRACKET, LOWER VALVE, 3203/4004 NON-PROP.
9	-	-	-	-	320991229	BRACKET, UPPER VALVE, 3203/4004 NON-PROP.
10	1	1	1	1	320991226	BRACKET, UPPER TWECO NEXSTAR 3203/4004EH
11	-	-	-	-	600318000	CABLE ASSY, 6 AWG, 11" WIRE LGTH, ø3/8 TMNL, ø5/16 TMNL
12	-	-	-	-	660116000	CABLE ASSY, 6 AWG, 16 1/4" WIRE LGTH, ø3/8 TMNL, ø5/16 TMNL
13	1	1	1	1	320991291	CABLE, 2GA 5/16 TERM 24LG
14	1	1	1	1	320991292	CABLE, 2GA 5/16-3/8 TERM 29LG
15	-	-	-	-	320991221	COVER, VALVE, SMALL EH, NON-PROP.
16	1	1	1	1	320991224	COVER, VALVE/RECIEVER NEXSTAR
17	1	1	1	1	330472	CUP HOUSING WITH CUPS
18	1	1	1	1	320845000	CYLINDER, LIFT
19	2	2	2	2	490198	FITTING 10SAE(M)/6JIC ELBOW 90
21	3	3	3	3	200876	FITTING 6 SAE/6 JIC STRAIGHT
21	2	2	2	2	202755000	FITTING, -10 SAE/-6 JIC, STR
22	-	-	-	-	360447000	FITTING, CAP, JIC, -6
23	1	1	1	1	320991282	GEAR, WORM, 6.667PD, 4.00 ID, w/GROUND, 3203
24	-	-	-	-	320442	GUARD CABLE RETAINER
25	1	-	1	-	320991257	HARNESS, ELEC SMALL EH FM NEXSTAR
26	-	1	-	1	320991267	HARNESS, ELEC SMALL EH HW NEXSTAR
27	2	2	2	2	812026014	HOSE, 1/4" x 3/8"JICF x 3/8"JICF x 14"
28	2	2	2	2	812026016	HOSE, 1/4" x 3/8"JICF x 3/8"JICF x 16"
29	1	1	-	-	812026017	HOSE, 1/4" x 3/8"JICF x 3/8"JICF x 17"
30	1	1	-	-	812026018	HOSE, 1/4" x 3/8"JICF x 3/8"JICF x 18"
31	2	2	2	2	812026031	HOSE, 1/4" x 3/8"JICF x 3/8"JICF x 31"
32	1	1	1	1	812206019	HOSE, 3/8" x 3/8"JICF x 3/8"JICF 90° LONG x 19"
33	1	1	1	1	812206027	HOSE, 3/8" x 3/8"JICF x 3/8"JICF 90° LONG x 27"
34	1	1	1	1	340602	KEY, 3/4 SQ X 1
35	1	-	-	-	320991250	KIT, ELEC/HYD 3203PRX/4004EH FM

# 3203EH PEDESTAL ASSEMBLY

## P/N 3209912XX

ITEM NO.	-201 PRX-FM	-202 PRX-TH	-203 PR-FM	-204 PR-TH	PART NUMBER	DESCRIPTION
36	-	1	-	-	320991260	KIT, ELEC/HYD 3203/4004 NEXSTAR TETHERED
37	-	-	1	-	320991255	KIT, ELEC/HYD 3203PR NEXSTAR FM
38	-	-	-	1	320991265	KIT, ELEC/HYD 3203PR NEXSTAR TETHERED
39	1	-	1	-	320991290	KIT, HARNESS SMALL EH FM NEXSTAR
40	-	1	-	1	320991295	KIT, HARNESS SMALL EH TETHERED NEXSTAR
41	-	-	1	1	320991245	KIT, HOSE NEXSTAR 3203PR
42	1	1	-	-	320991240	KIT, HOSE NEXSTAR 3203PRX/4004EH
43	-	-	-	-	320988270	KIT, HYDRAULIC, 3203 PR
44	-	-	-	-	320988251	KIT, HYDRAULIC, 3203 PRX/ 4004
45	-	-	-	-	680156100	KIT-ELECTRICAL, 3203 PR/PRX
46	1	1	1	1	404241285	MOTOR, HYD 8.0 CU IN, SAE 2-BOLT 1" SHAFT
47	2	2	2	2	480024	MOUNT PENDANT CABLE RETAINER
48	5	5	5	5	17701	NUT HX 1/2-13UNC
49	-	-	-	-	15900	NUT HX 1/4-20UNC SS
50	6	6	6	6	330372	NUT HX 3/8-16UNC
51	5	5	5	5	15801	NUT HX NYLK #10-24UNC ZP
52	2	2	2	2	17301	NUT HX NYLK 3/8-16UNC CP
53	1	1	1	1	19000	NUT HX NYLK 7/8-14UNF
54	1	1	1	1	320991215	PEDESTAL WMT, 3203/4004 EH
55	1	1	1	1	360678000	PIN, 3/16 COTTERLESS RING
56	1	1	1	1	366823240	PIN, 3/16 W/LANYARD
57	1	1	1	1	320824000	PIN, LIFT CYLINDER
58	-	-	-	-	320991279	POWER UNIT, ENTRY LEVEL 3203/4004 EH
59	1	1	1	1	320991270	POWER UNIT, NEXSTAR 3203/4004 EH
60	-	1	-	1	320917000	PRESSURE SWITCH, N.C. 1,900 PSI
	1	-	1	-	366823255	TRANSDUCER, PRESSURE 0-3000 PSI
61	1	-	1	-	366823252	RECEIVER, PROPORTIONAL W/LCD
	-	1	-	1	320991262	CONTROLLER, NEXSTAR 3203/4004 TETHERED
62	-	-	-	-	320988300	RELAY PANEL ASSEMBLY, 3203
63	1	1	1	1	404028	RETAINING RING, SNAP RING
64	1	1	1	1	320878000	ROTATION BEARING
65	1	1	1	1	10201	SCREW HX HD 1/2-13UNC x 1 1/2 LG
66	4	4	4	4	738647000	SCREW HX HD 1/2-13UNC X 1 1/4 LG GR8
67	2	2	2	2	11603	SCREW HX HD 1/2-13UNC X 1 3/4 LG
68	2	2	2	2	11608	SCREW HX HD 1/2-13UNC X 2 LG

# 3203EH PEDESTAL ASSEMBLY

## P/N 3209912XX

ITEM NO.	-201 PRX-FM	-202 PRX-TH	-203 PR-FM	-204 PR-TH	PART NUMBER	DESCRIPTION
69	-	-	-	-	6200	SCREW HX HD 1/4-20UNC X 1 1/4 LG
70	-	-	-	-	5500	SCREW HX HD 1/4-20UNC X 3/4 LG
71	5	5	5	5	9109000	SCREW HX HD 3/8-16UNC X 1 1/2 LG
72	1	1	1	1	404198000	SCREW HX HD 3/8-16UNC X 1 1/2 LG, BRONZE
73	1	1	1	1	8702000	SCREW HX HD 3/8-16UNC X 1 1/4 LG GR5
74	1	1	1	1	330371	SCREW HX HD 3/8-16UNC X 1 LG GR8
75	1	1	1	1	8400	SCREW HX HD 3/8-16UNC X 3/4 LG GR 5
76	5	5	5	5	7807	SCREW HX HD 5/16-18UNC X 3/4 LG GR5
77	23	23	23	23	12198	SCREW HX HD 5/8-11UNC X 1 3/4 LG GR8
78	5	5	5	5	460094000	SCREW, SOC HD, #10-24 X 1"L, ZPL
79	1	1	1	1	404213000	SEAL, 2.50 OD X 1.5 ID
80	2	2	2	2	330486	SEAL, OIL
81	1	1	1	1	330483	SPACER
82	1	1	1	1	320879000	SPACER ROTATION
83	1	1	1	1	320991225	SPRING PLATE, GROUND 3203/4004EH
84	-	-	1	-	320991263	TAG, ID 3203PR
85	1	-	-	-	320991253	TAG, ID 3203PRX/FX
86	1	1	1	1	645000	TWECO, MALE MODIFIED
87	-	-	-	-	320989420	VALVE ASSY, 3 SPOOL, NON-PROP., 12 VOLT
88	-	-	1	1	320991261	VALVE BLOCK, 3203PR PROPORTIONAL
	1	1	-	-	320991251	VALVE BLOCK, 3203PRX/4004EH PROPORTIONAL
89	-	-	-	-	320988261	VALVE, FLOW REGULATOR, IN-LINE
90	5	5	5	5	20600	WASHER 5/16 LOCK SS
91	5	5	5	5	20000	WASHER FL #10 ZP
92	5	5	5	5	21600	WASHER FL 1/2
93	8	8	8	8	21200	WASHER FL 3/8
94	23	23	23	23	23902	WASHER FL 5/8 HARDENED
95	-	-	-	-	20200	WASHER SP LK 1/4
96	6	6	6	6	21100	WASHER SP LK 3/8
97	-	-	-	-	20601	WASHER SP LK 5/16
98	9	9	9	9	21500000	WASHER, SP LK 1/2
99	1	1	1	1	123331	HOIST, RPH2000
100	-	-	-	-	110703	WINCH-DCG8R FOR AUTOCRANE #3203 PRX
101	1	1	1	1	404015	WORM SHAFT
102	2	2	2	2	239300	ZERK, GREASE
103	1	1	1	1	320991293	CABLE, 2GA, 1/4-3/8 TERM, 72"LG

# ***NOTES***



# 3203EH BOOM ASSEMBLY

## P/N: 320988100/101 PR,PRX

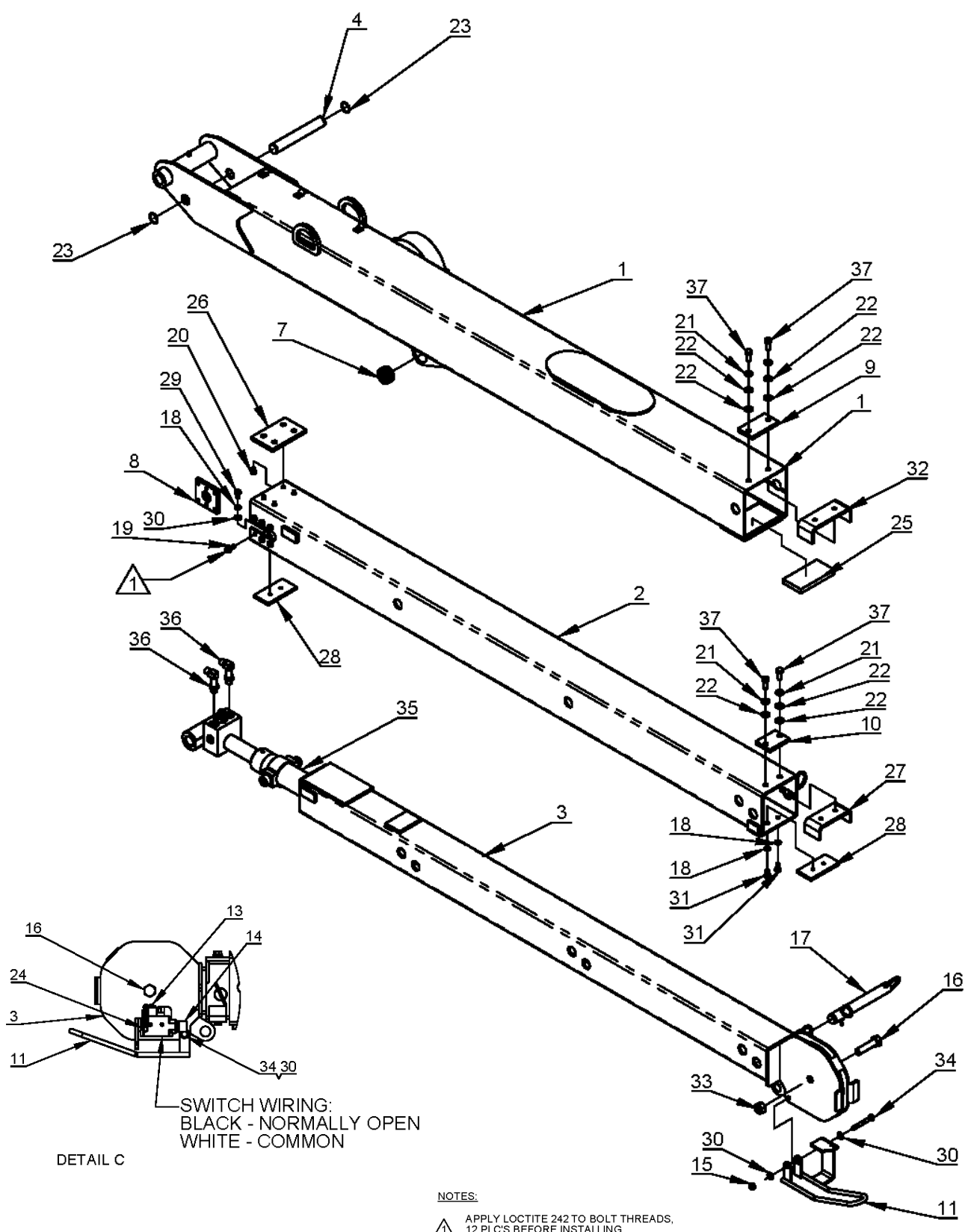

# 3203EH BOOM ASSEMBLY

## P/N: 320988100/101 PR,PRX

ITEM NO.	3203 PRX -100	3203 PR -101	PART NUMBER	DESCRIPTION
1	1	1	320988110	LOWER BOOM WELDMENT, 3203
2	1	1	320988120	MID BOOM WLDMNT, 3203
3	1	1	320988130	UPPER BOOM WLDMT 3203
4	1	-	320988115	PIN 1 DIA X 6.905 LG, 3203
5	1	1	404205000	CORD REEL ASSY
6	1	1	239000000	ZERK DRIVE GR
7	1	1	320858000	BEARING, SPHERICAL 1.00 ID
8	2	2	320888000	RETAINER, EXTENSION CYLINDER
9	1	1	366201000	WEAR PAD 3 .75 X 2.00 X .313
10	1	1	366202000	PAD, BOOM TOP
11	1	1	320871000	BAIL WELDMENT
12	1	1	320883000	SHEAVE ASSEMBLY
13	1	1	646900000	SWITCH, ANTI-TWO BLOCK
14	1	1	642918000	CORD CONNECTOR
15	1	1	168010000	NUT HX NYLK 5/16-18UNC CP
16	1	1	366393000	SCREW HX HD 5/8-11UNC X 2 1/2 LG GR8
17	1	2	366190000	PIN ASSY W/LANYARD
18	4	4	206000000	WASHER 5/16 LOCK SS
19	12	12	780700000	SCREW HX HD 5/16-18UNC X 3/4 LG GR5
20	4	4	540600000	SCREW HX HD 1/4-28UNF X 1/2 LG
21	4	4	211000000	WASHER SP LK 3/8
22	7	3	212000000	WASHER FL 3/8
23	2	-	360122000	RING RETAINING 5100-98
24	1	1	366678000	SPRING, EXTENSION
25	1	1	320988155	BOOM PAD 4.75 X 2.50 X .50, 3203
26	1	1	320988156	BOOM PAD WITH NUTS, 4.75 X 3 X .313
27	1	1	366112000	STOP UPPER BOOM
28	2	2	366199000	PAD BOOM
29	2	2	780800000	SCREW 5/16-24UNF X 1/2 LG
30	6	6	209010000	WASHER FL 5/16
31	2	2	320988132	SCREW HX HD 5/16-24UNF X 5/8 LG GR 5
32	1	1	366183000	STOP CENTER BOOM
33	1	1	182000000	NUT HX NY LK 5/8-11UNC
34	1	1	811029000	SCREW HX HD 5/16-18UNC X 2 1/2 LG
35	1	-	320988142	EXTENSION CYLINDER, 3203
36	2	-	330645000	FITTING 90 6-SAE/6-JIC LONG
37	4	4	738733100	SCREW HX HD 3/8-24UNF X 7/8 LG

# 3203EH PRFX BOOM ASSEMBLY

## P/N: 320990100 PRFX

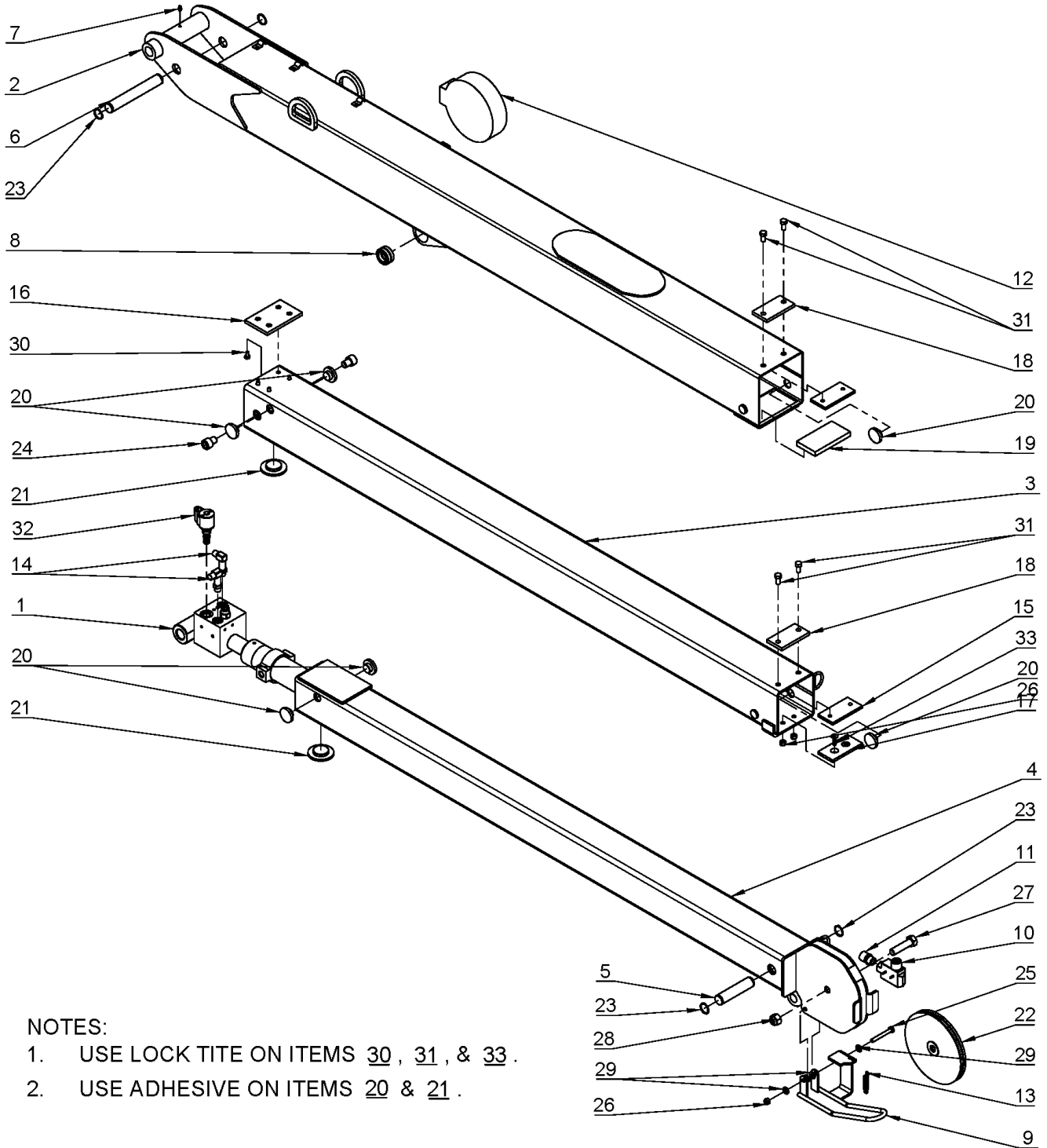

**NOTES:**

1. USE LOCK TITE ON ITEMS 30 , 31 , & 33 .
2. USE ADHESIVE ON ITEMS 20 & 21 .

# 3203EH PRFX BOOM ASSEMBLY

## P/N: 320990100

ITEM NO.	QTY	PART NUMBER	DESCRIPTION
1	1	320988145	CYLINDER, TELESCOPIC, 48" FIRST STAGE, 48"
2	1	320990110	LOWER BOOM WELDMENT, 3203PRFX
3	1	320990120	MID BOOM WLDMNT, 3203PRFX
4	1	320990130	UPPER BOOM WLDMT 3203PRFX
5	1	738732000	PIN 1 $\phi$ X 4.063 LG
6	1	320988115	PIN 1 DIA X 6.905 LG, 3203
7	1	239000000	ZERK DRIVE GR
8	1	320858000	BEARING, SPHERICAL 1.00 ID
9	1	320871000	BAIL WELDMENT
10	1	646900000	SWITCH, ANTI-TWO BLOCK
11	1	642918000	CORD CONNECTOR
12	1	404205000	CORD REEL ASSY
13	1	366678000	SPRING, EXTENSION
14	2	330645000	FITTING 90 6-SAE/6-JIC LONG
15	2	366483000	PLATE, WEAR PAD .25 X 2 X 4
16	1	320988156	BOOM PAD WITH NUTS, 4.75 X 3 X .313, 3203
17	1	320990104	WEAR PAD, 2 X 4 X .25, W/ CSINK HOLES
18	2	366201000	WEAR PAD 3 .75 X 2.00 X .313
19	1	320988155	BOOM PAD 4.75 X 2.50 X .50, 3203
20	8	360767000	PAD BOOM 1.5 O.D.
21	2	407202000	PAD BOOM 2.50 O.D.
22	1	320883000	SHEAVE ASSEMBLY
23	4	360122000	RING RETAINING 5100-98
24	2	460177162	SCREW SOC HD 5/8-11UNC X 3/4 LG
25	1	811029000	SCREW HX HD 5/16-18UNC X 2 1/2 LG
26	3	168010000	NUT HX NYLK 5/16-18UNC CP
27	1	366393000	SCREW HX HD 5/8-11UNC X 2 1/2 LG GR8
28	1	182000000	NUT HX NY LK 5/8-11UNC
29	4	209010000	WASHER FL 5/16
30	4	540600000	SCREW HX HD 1/4-28UNF X 1/2 LG
31	4	738733000	SCREW HX HD 3/8-24UNF X 3/4 LG
32	1	320990101	VALVE, SPOOL, 3-WAY, W/ COIL & DEUTSCH CON.
33	2	320990105	SCREW, FLAT HEAD, 5/16-18 UNC X 1, ZP

# 3203EH PR/PRX HOIST ASSEMBLY

## P/N: 123331

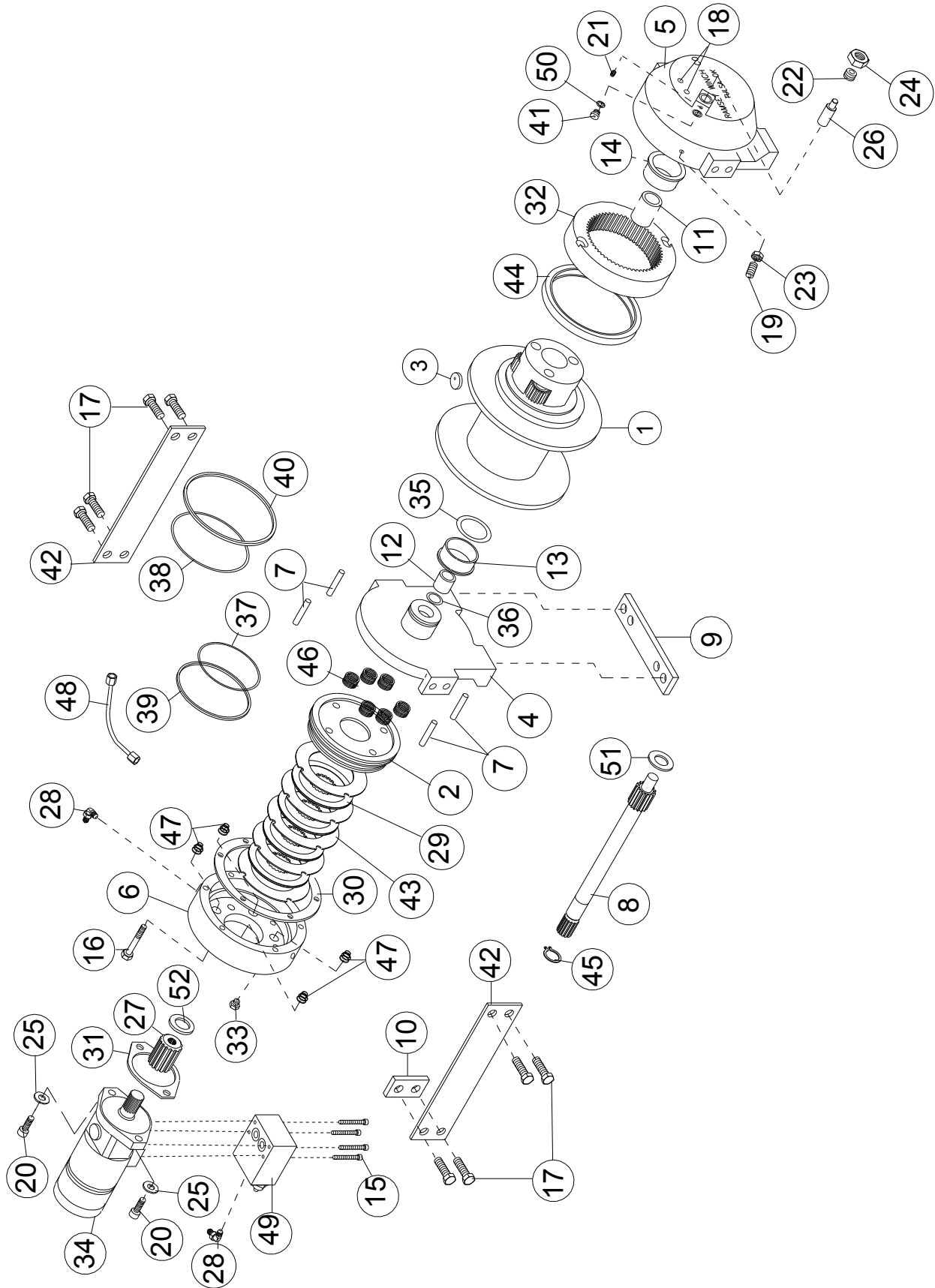

# 3203EH PR/PRX HOIST ASSEMBLY

## P/N: 123331

ITEM NO.	QTY.	PART NO.	DESCRIPTION
1	1	234189	DRUM ASSEMBLY
2	1	306042	PISTON-BRAKE
3	1	315004	ANCHOR- CABLE
4	1	338300	END BRG-MOTOR END
5	1	338301	END BRG-GEAR HSG.
6	1	338302	HSG-BRAKE
7	4	346045	PIN-BRAKE
8	1	357513	SHAFT- INPUT
9	2	408435	PLATE WINCH MOUNTING RPH 2000
10	4	362284	SPACER - TIE PLATE
11	1	402120	BEARING-GARLOK BRG.#12U16 OR EQUIV.
12	1	402121	BEARING-RPH12,GARLOCK BRG#16DU08/EQ
13	1	412084	BUSHING-DRUM,MOTOR END
14	1	412085	BUSHING-DRUM,GEAR END
15	4	414129	CAPSCREW 5/16-18NCX3 LG HX HD GR-5
16	6	414303	BOLT-3/8-16NC X2 1/2,HXHD,GR-5, Z/P
17	8	414548	CAPSCREW-1/2-13NCX1 1/2,HXHD,Z/P,G5
18	2	414854	SCREW-1/4-20NCX1/2LG,RDHD,SLOT,Z/PL
19	1	414926	SETSCREW-3/8-16NC X1,SOCKET,NYLON
20	2	414948	CAPSCREW-1/2-13NCX1 1/4LG,SOCKET HD
21	1	416016	SETSCREW1/4-20NCX1/4 HX SOCK HD CUP
22	1	416080	SETSCREW-5/8-18NF X1 LG,HXSOCHD,CUP
23	1	418036	NUT-3/8-16 NC,HEX JAM,Z/P
24	1	418088	NUT-JAM 5/8-18NF HEX HD,ZINC PLT
25	2	418218	LOCKWASHER-1/2 ID MED SECT,ZINC PLT
26	1	426048	PLUNGER-CLUTCH,BLOCKED,RPH12/15000
27	1	431015	COUPLING-MOTOR,P/M, RPH-12000
28	2	432018	FITTING #4-C5OX-S T-LOK, 7/16-20 90 degree
29	4	438022	DISC-BRAKE
30	1	442220	GASKET-BRAKE HSG.,RPH12000,#VCN-60
31	1	442223	GASKET-MOTOR FLANGE,RPH12000
32	1	444085	GEAR-RING,P/M,RPH-12000
33	1	456038	FITTING-VENT,BREATHER,#ASP-1BV/EQV
34	1	458195	MOTOR, HYD. 6.0 CU IN, 1" KEYED SHAFT
35	1	462046	O-RING 1/8X2 1/4 OD X 2, AS-568-226
36	1	462056	O-RING-AS-568-214
37	1	462057	O-RING-AS-568-256
38	1	462058	O-RING-AS-568-259
39	1	462059	RING-BACK-UP,VERCO #1750-256
40	1	462060	RING-BACK-UP,VERCO #1750-259

# NOTES

ITEM NO.	QTY.	PART NO.	DESCRIPTION
41	1	472052	PLUG-SAE O-RING,.562-18NF,HXSOC
42	2	474065	TIE PLT-7GAX2.25X10.25,W/Y-DM,IPH8Y
43	5	474111	PLATE-SEPARATOR,BRAKE,RPH-12000
44	1	486080	SEAL-GH,MIKRON #RWH-675,MB-2590,RPH
45	1	490037	SNAP RING-TRUARC #5100-93,OR EQUIV.
46	6	494110	SPRING-BRAKE,ASSOC#CV1000-1000-158
47	4	494112	SPRING-RPH12000,PRESSURE TO BRAKE
48	1	509009	TUBE ASSY-1/4OD,HYD.BRK.,RPH-12000
49	1	516033	VALVE-MOTOR CONTROL 4.5:1 RATIO
50	1	518037	THRUST WASHER-TORRINGTON #TRA-1018
51	1	518047	THRUST WASHER,0.063 THK.X1.50 OD
52	1	518052	THRUST WASHER,1.37 O.D.,RPH-12000

# 3203EH TRAVELING BLOCK ASSEMBLY

## P/N: 320433000

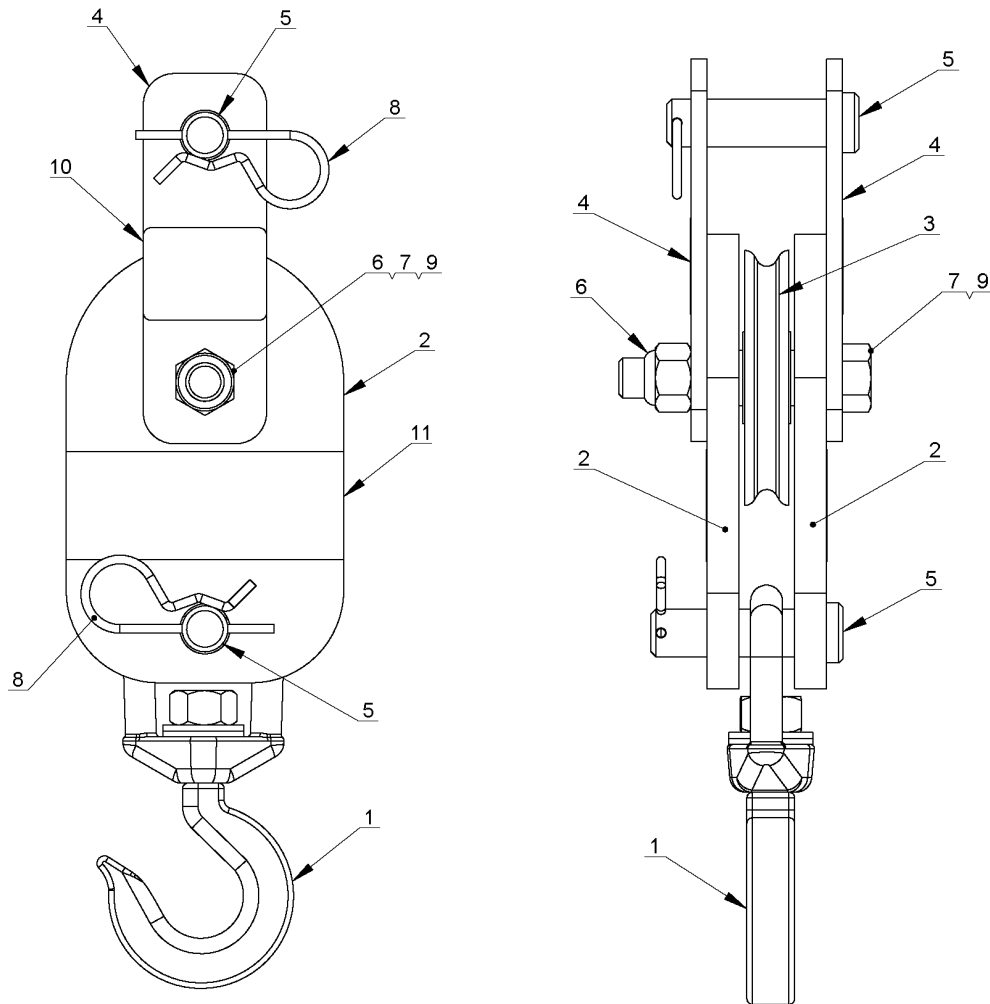

ITEM NO.	QTY	PART NUMBER	DESCRIPTION
1	1	100309000	SWIVEL HOOK ASSY W/LATCH
2	2	320403000	SIDE PLATE, 3203
3	1	200909000	SHEAVE ASSEMBLY
4	2	320404000	BLOCK TRAVELING
5	2	320434001	PIN, 3/4 X 2-3/4LG
6	1	182000000	NUT HX NY LK 5/8-11UNC
7	1	135120000	SCREW HX HD 5/8-11UNC X 3 1/2 LG
8	2	366813000	PIN HITCH
9	2	330100000	WASHER, FL 5/8 X 7/8 OD
10	2	320433100	DECAL, TRAVELING BLOCK 3203
11	2	405180000	DECAL STAY CLEAR OF LOAD



# 3203EH MAIN HARNESS — FM

## P/N: 320991257

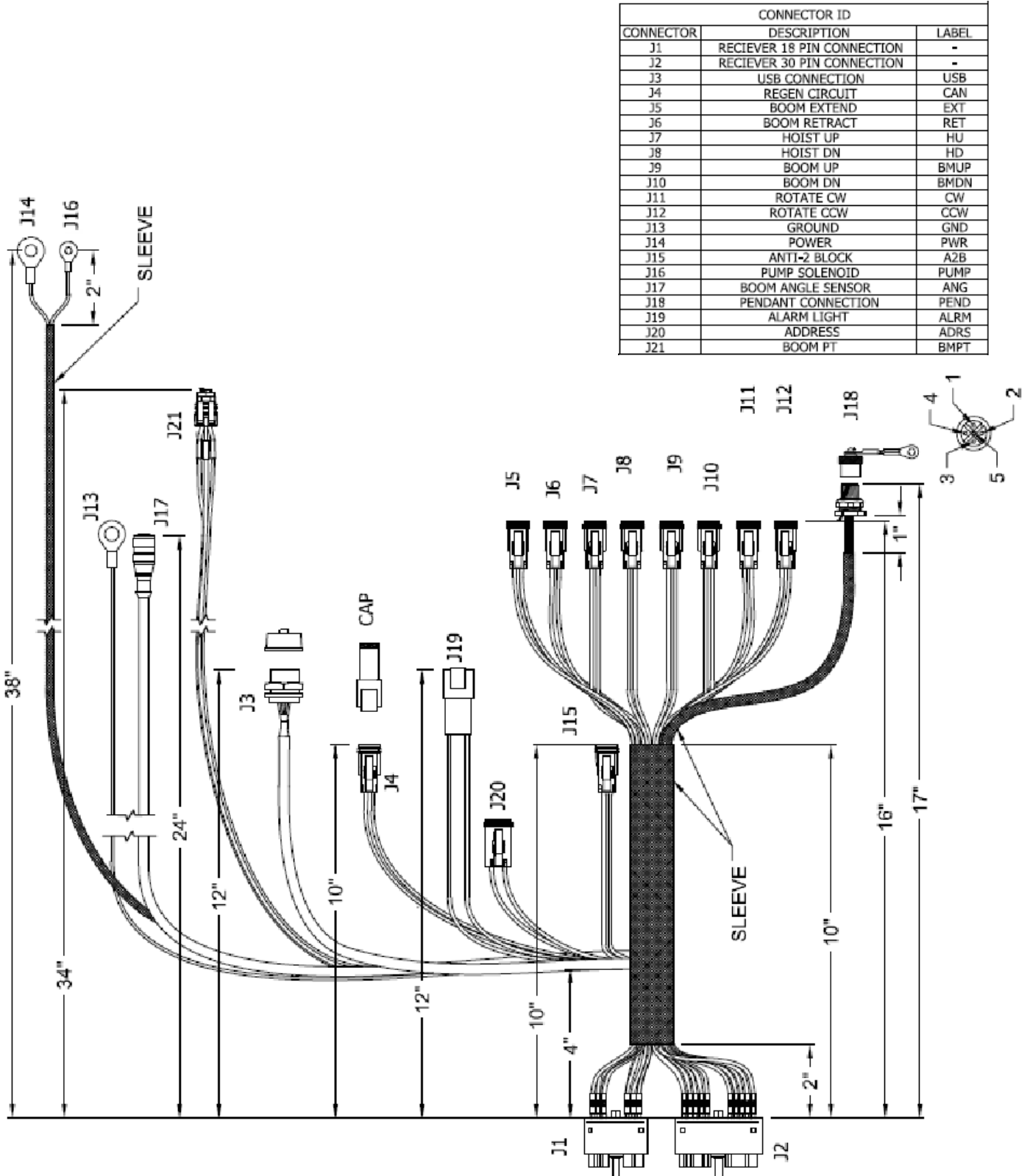

# 3203EH MAIN HARNESS — FM

## P/N: 320991010

**NOTE:**

1. ALL JUMPERS TO BE 4" FROM CONNECTORS TO J1 & J2.
2. ALL WIRES TO BE 18 GAUGE UNLESS SPECIFIED.

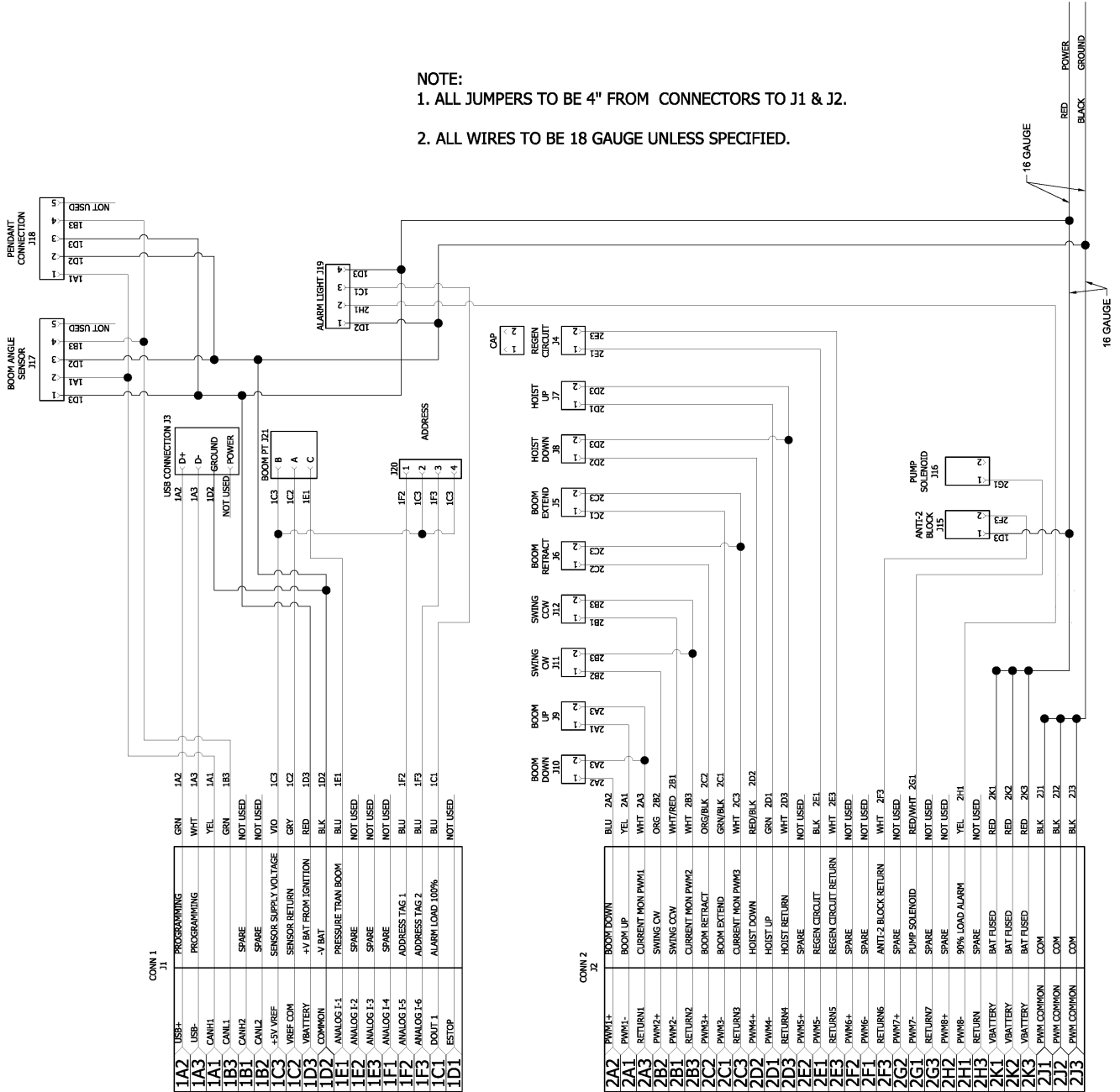

# 3203EH MAIN HARNESS — TETHERED

## P/N: 320991267

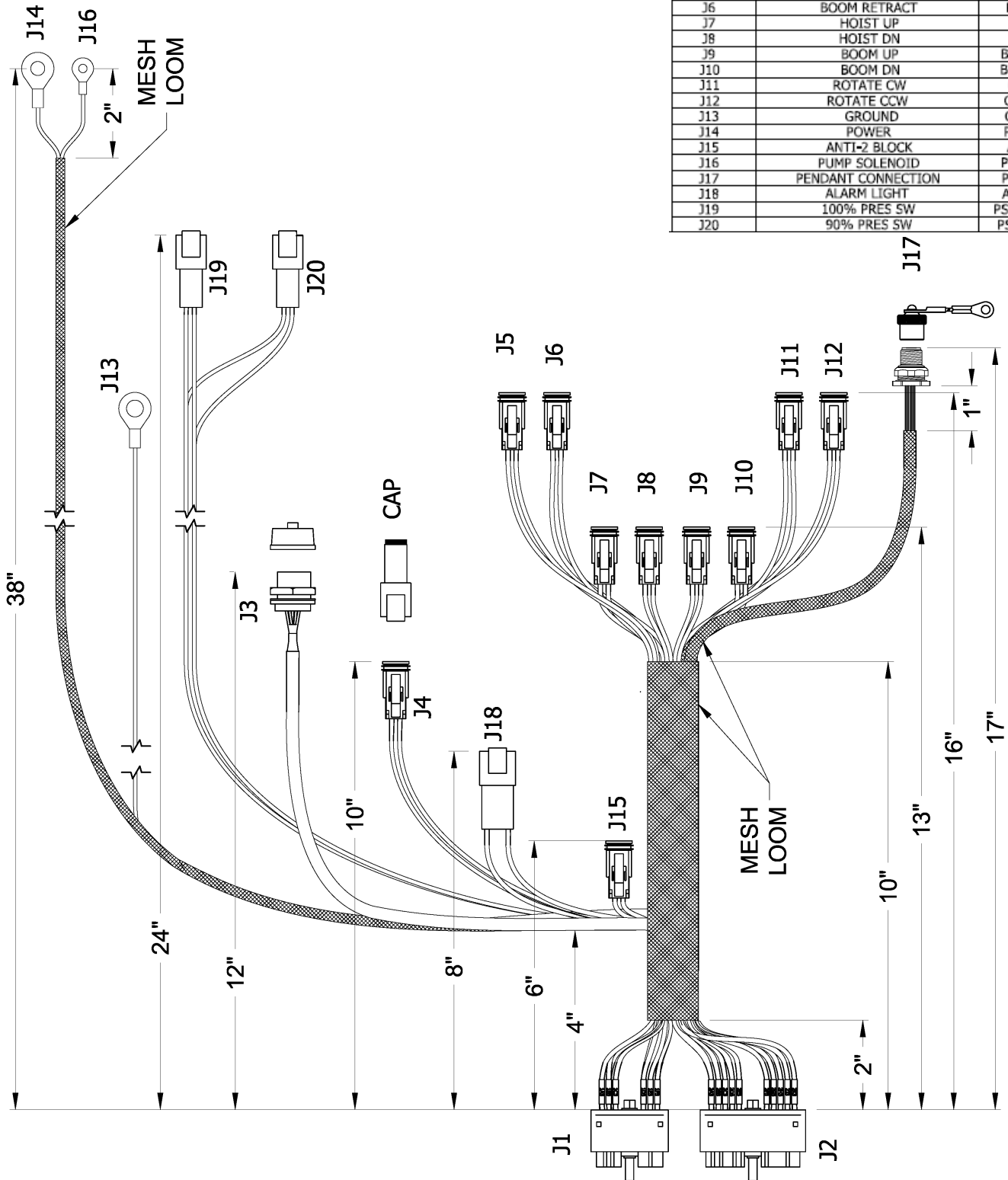

CONNECTOR ID		
CONNECTOR	DESCRIPTION	LABEL
J1	RECIEVER 18 PIN CONNECTION	-
J2	RECIEVER 30 PIN CONNECTION	-
J3	USB CONNECTION	USB
J4	REGEN CIRCUIT	CAN
J5	BOOM EXTEND	EXT
J6	BOOM RETRACT	RET
J7	HOIST UP	HU
J8	HOIST DN	HD
J9	BOOM UP	BMUP
J10	BOOM DN	BMDN
J11	ROTATE CW	CW
J12	ROTATE CCW	CCW
J13	GROUND	GND
J14	POWER	PWR
J15	ANTI-2 BLOCK	A2B
J16	PUMP SOLENOID	PUMP
J17	PENDANT CONNECTION	PEND
J18	ALARM LIGHT	ALRM
J19	100% PRES SW	PSW100
J20	90% PRES SW	PSW90



# 3203EH PRX HYDRAULIC CONTROL VALVE

## P/N: 320991251

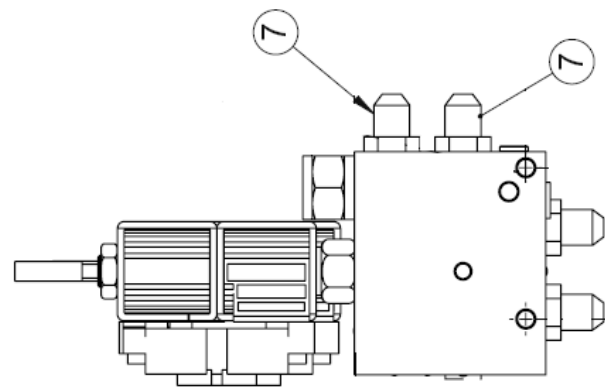
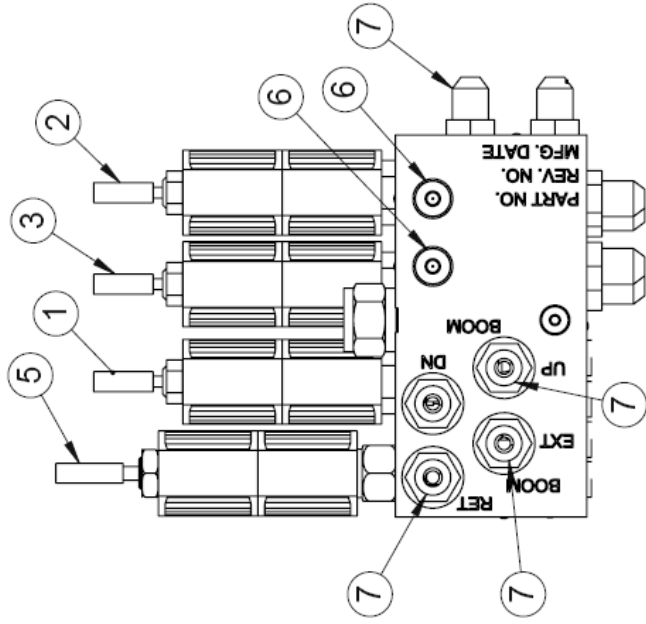
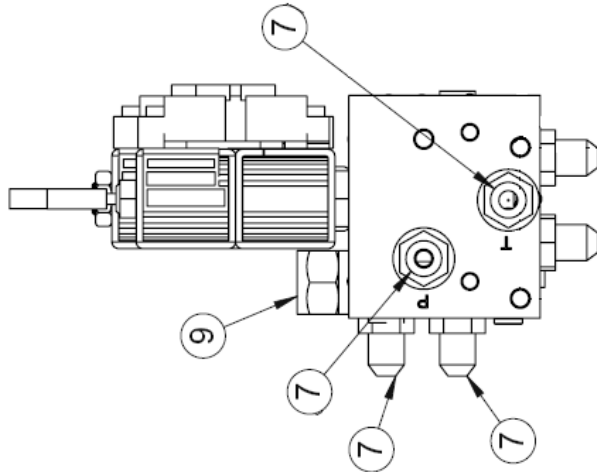

# 3203EH PRX HYDRAULIC CONTROL VALVE

## P/N: 320991251

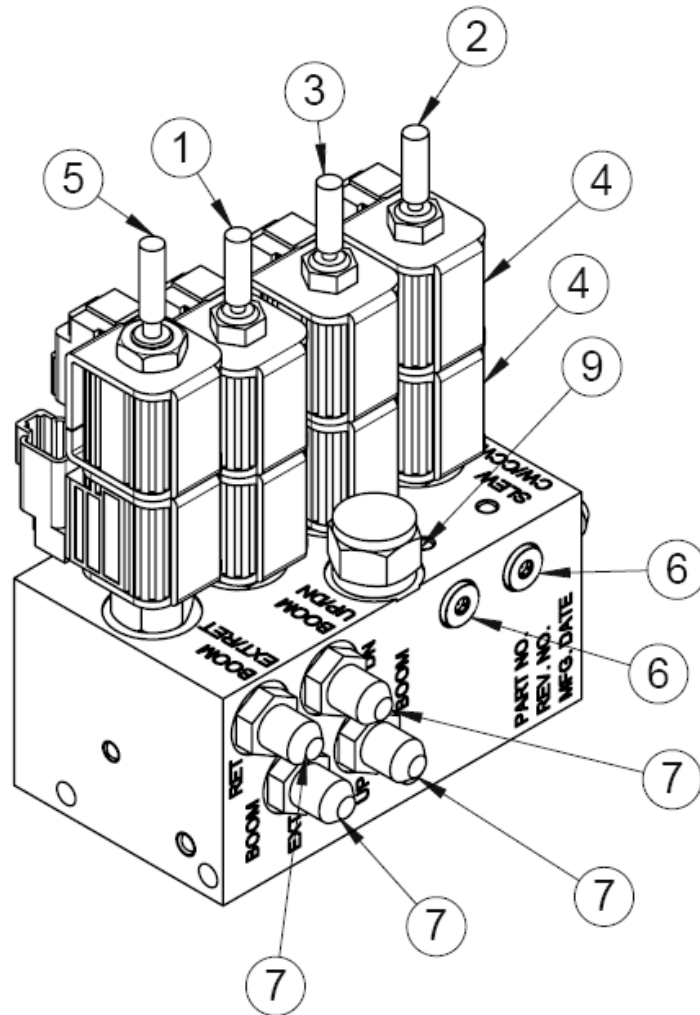

ITEM NO.	QTY	PART NUMBER	DESCRIPTION
1	1	320991914	VALVE, CARTRIDGE PROPOTIONAL 3203/4004 NEXSTAR FLOAT CENTER
2	1	320991912	VALVE, CARTRIDGE PROPOTIONAL 3203/4004 NEXSTAR CLOSED CENTER
3	1	320991913	VALVE, CARTRIDGE PROPOTIONAL 3203/4004 NEXSTAR FLOATING CENTER
4	8	320991901	COIL, SOLENOID 12VDC 1/2" DIA
5	1	320991902	VALVE, CARTRIDGE 3203/4004 NEXSTAR
6	8	320991905	VALVE, CHECK SIZE 04
7	10	200876	FITTING 6 SAE/6 JIC STRAIGHT
8	1	320991904	ORIFICE, 1/4-20UNC 3/8LG 0.018 DIA
9	1	320991903	VALVE, LOGIC

# 3203EH PR HYDRAULIC CONTROL VALVE

## P/N: 320991261

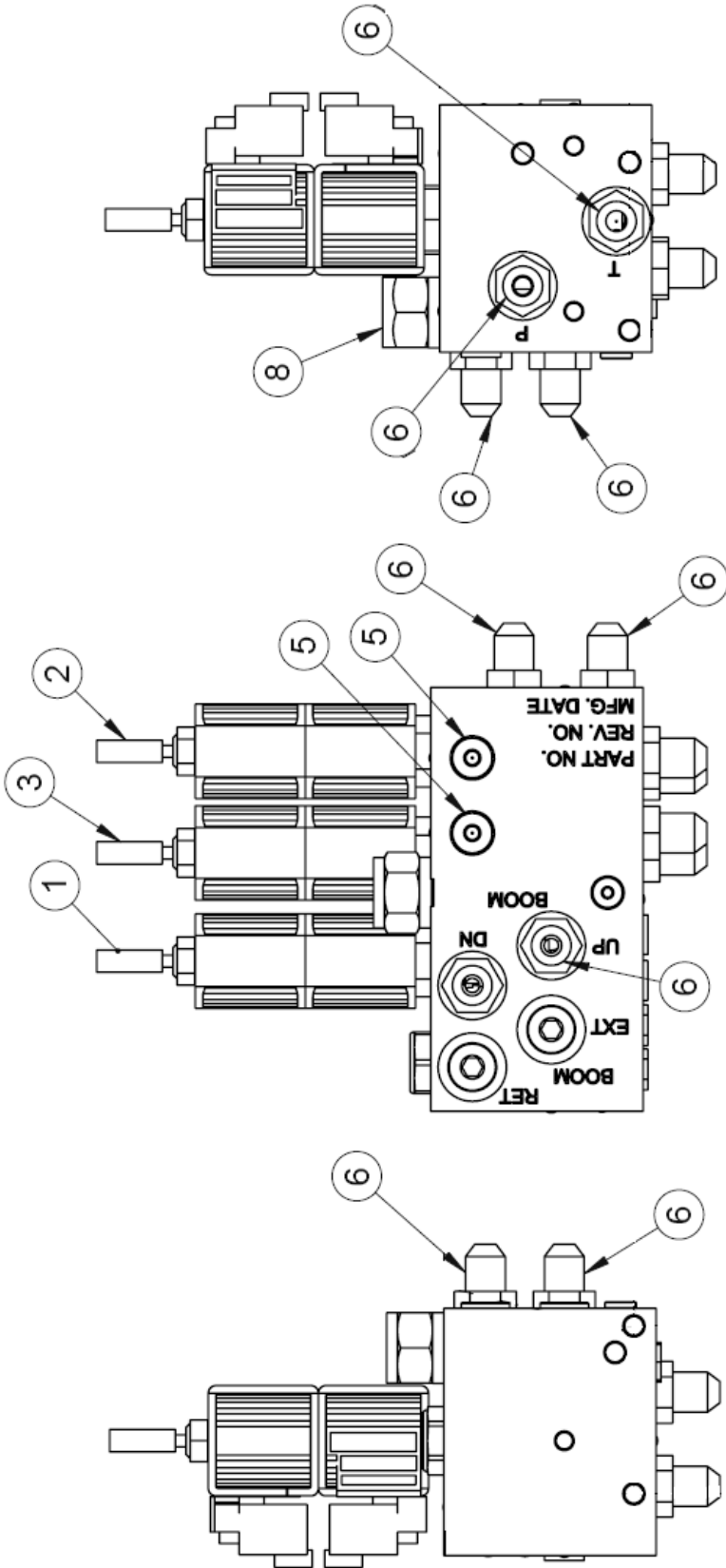

# 3203EH PR HYDRAULIC CONTROL VALVE

## P/N: 320991261

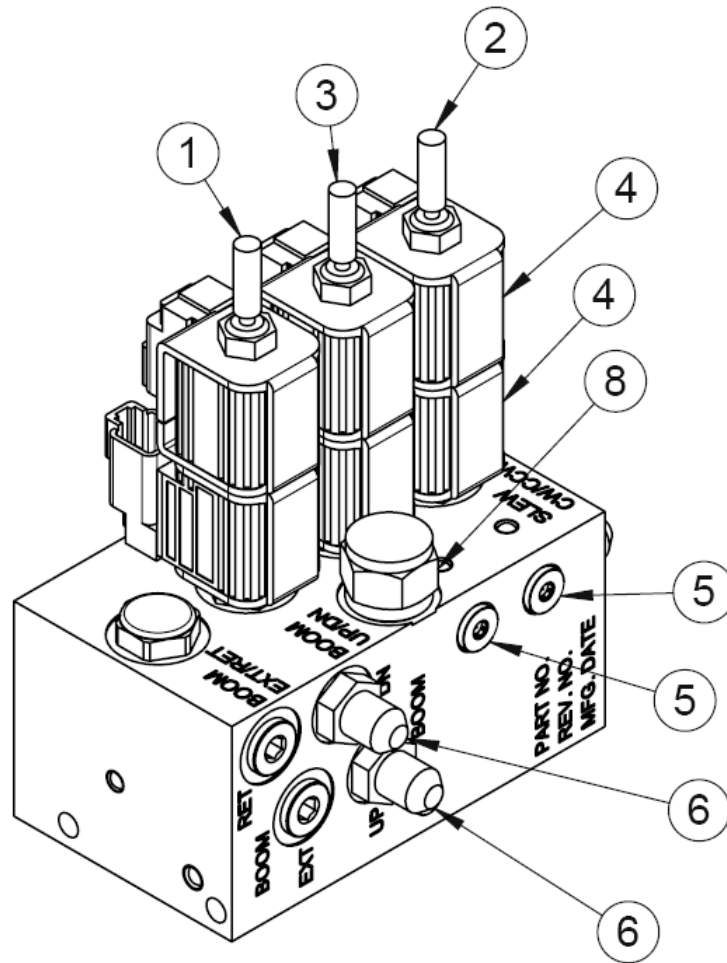

ITEM NO.	QTY	PART NUMBER	DESCRIPTION
1	1	320991914	VALVE, CARTRIDGE PROPOTIONAL 3203/4004 NEXSTAR FLOAT CENTER
2	1	320991912	VALVE, CARTRIDGE PROPOTIONAL 3203/4004 NEXSTAR CLOSED CENTER
3	1	320991913	VALVE, CARTRIDGE PROPOTIONAL 3203/4004 NEXSTAR FLOATING CENTER
4	6	320991901	COIL, SOLENOID 12VDC 1/2" DIA
5	6	320991905	VALVE, CHECK SIZE 04
6	8	200876	FITTING 6 SAE/6 JIC STRAIGHT
7	1	320991904	ORIFICE, 1/4-20UNC 3/8LG 0.018 DIA
8	1	320991903	VALVE, LOGIC



# 3203EH NEXSTAR POWER UNIT 320991270

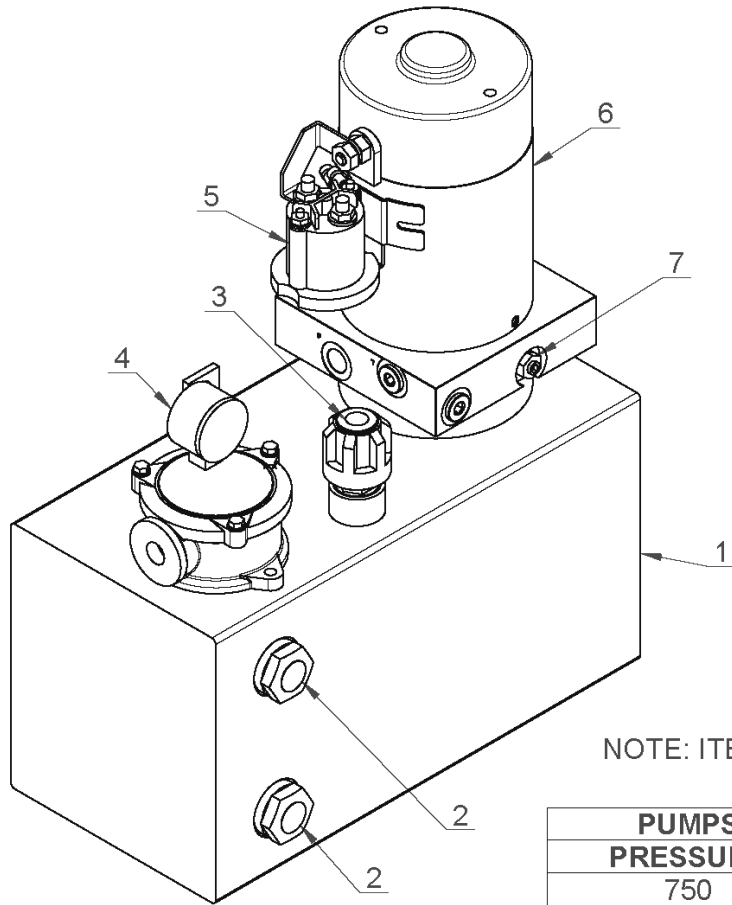

**NOTES:**

- 1.) REPLACEMENT FILTER ELEMENT  
PART NUMBER: RTE10D20B/S1 (A/C 320991910)

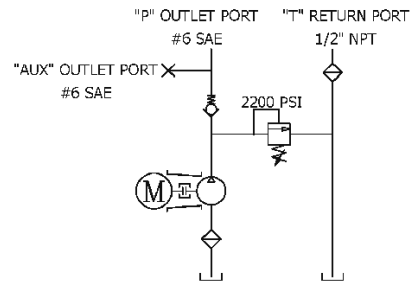

NOTE: ITEM 7 AND 8 NOT SHOWN IN DETAIL

PUMPS		
PRESSURE	FLOW	AMPS
750	1.9	128
1500	1.41	169
1750	1.3	183
2000	1.2	197
2750	0.98	239

ITEM NO.	QTY	PART NUMBER	DESCRIPTION
1	1	320991272	TANK, NEXSTAR 3203/4004EH
2	2	320991274	GLASS, SIGHT USED W/320991270
3	1	320991275	CAP, FILLER USED W/ 320991270
4	1	320991908	GAUGE, FILTER USED W/320991270
5	1	320991276	STARTER, MOTOR USED W/320991270
6	1	320991271	MOTOR, NEXSTAR 3203/4004EH
7	1	320991277	VALVE, RELIEF USED W/320991270
8	1	320991910	FILTER, ELEMENT SMALL EH NEXSTAR



# 3203EH

## MANUAL OVERRIDE PROCEDURE

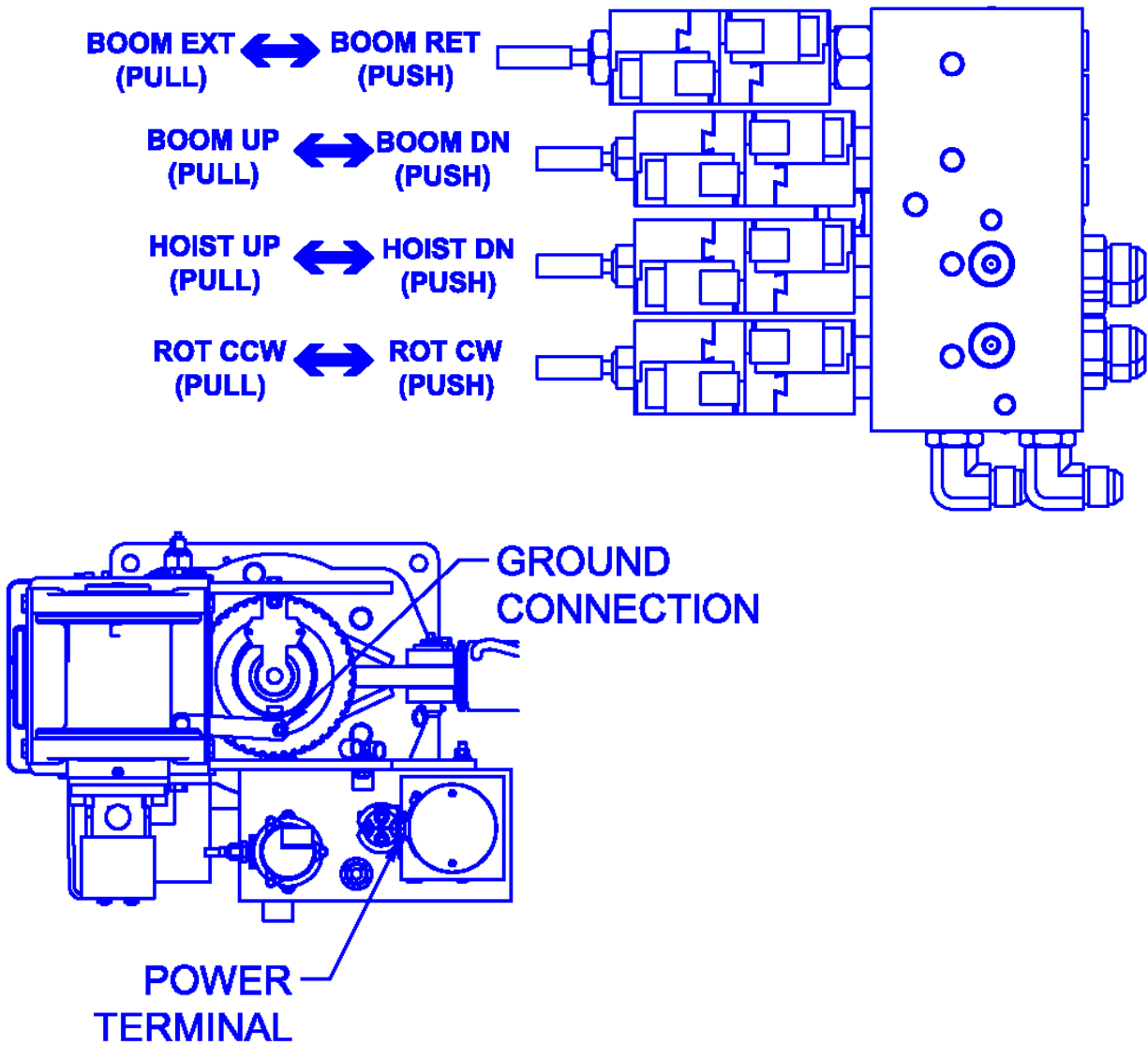

### MANUAL OVERRIDE PROCEDURES

- 1) APPLY 12VDC FROM BATTERY TO PUMP POWER TERMINAL
- 2) APPLY GROUND FROM BATTERY TO GROUNDING CONNECTION
- 3) SELECT THE FUNCTION DESIRED, THEN CLOSE THE GAP BETWEEN COLLAR AND THE END ON THE OVERRIDE BUTTON. (NOTE: BOOM EXTEND/RETRACT DOES NOT HAVE A COLLAR)
- 4) PUSH OR PULL THE OVERRIDE BUTTON FOR THE DESIRED DIRECTION OF MOVEMENT. THE FARTHER THE BUTTON IS DEPRESSED OR PULLED, THE FASTER THE FUNCTION WILL OPERATE.

# 3203EH TROUBLESHOOTING CHART

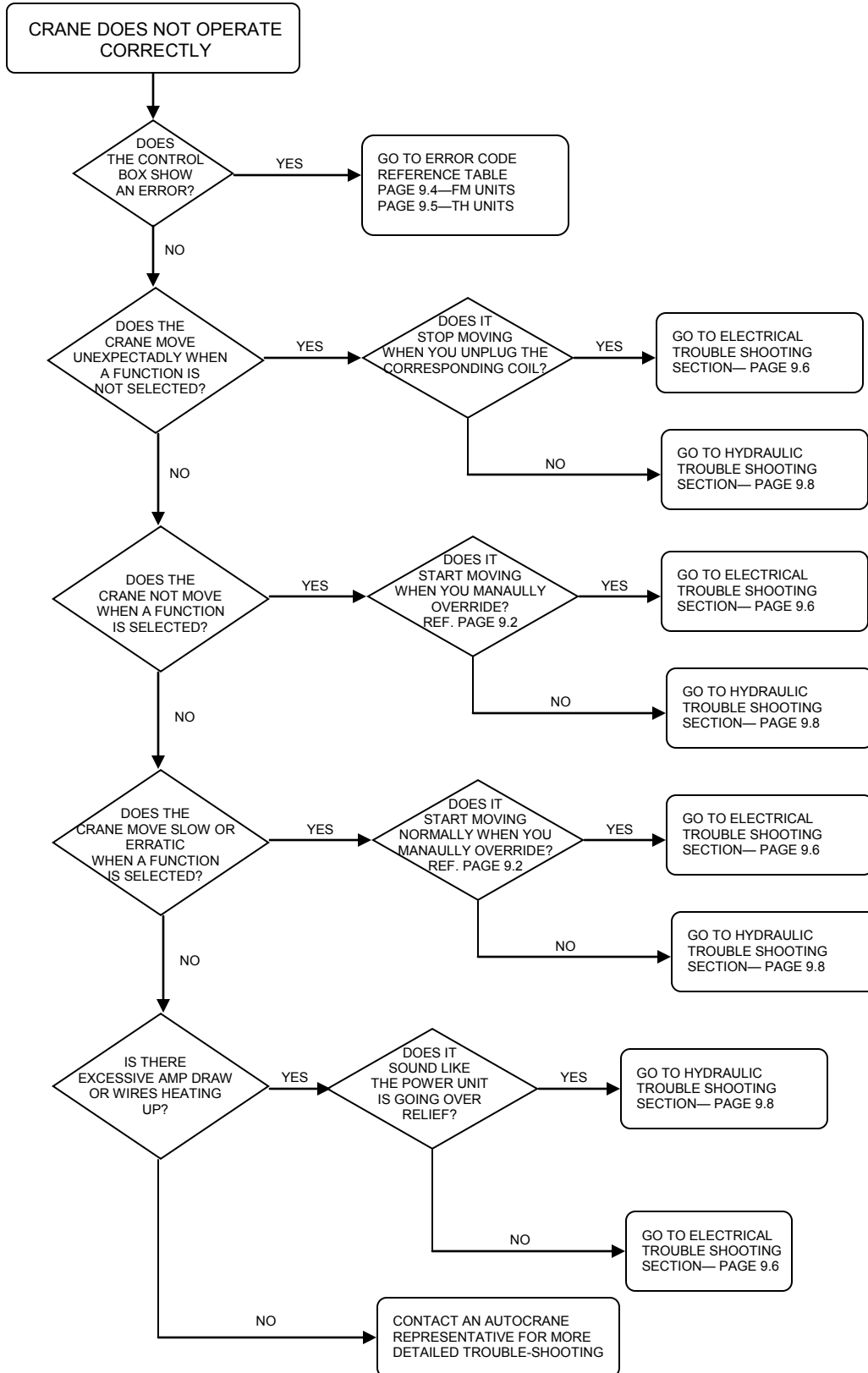

# 3203EH

## ERROR CODE TROUBLESHOOTING CHART

### FM UNITS ONLY

ERROR CODE	CAUSE	EFFECT	SOLUTION
S0. ESTOP ACTIVE	E-STOP ACTIVATED	ALL OUTPUTS WILL BE DISABLED	TURN ON TRANSMITTER. FOLLOW DE-ACTIVATING E-STOP PROCEDURES ON PAGE 3-3.0
S1. CAN RX TO	RECEPTION OF A CAN MESSAGE TIMED OUT	ALL OUTPUTS WILL BE DISABLED	DETERMINE WHY MESSAGE(S) IS(ARE) NOT BEING RECEIVED. WHEN PROBLEM IS CORRECTED THE ALARM WILL CLEAR
S2. TEMP OUT OF RANGE	OUTSIDE OPERATING TEMPERATURE -40C TO 85C	ALL OUTPUTS WILL BE DISABLED	GET TEMPERATURE INTO ACCEPTABLE RANGE. ALARM WILL CLEAR AFTER 1 MINUTE
S16-S31 OUT X OVER-CURRENT ERR	WHEN THE OUTPUT WAS ACTIVATED, A CURRENT OF OVER 3.5 A WAS BEING DRAWN.	THAT OUTPUT IS DISABLED	CYCLE POWER TO RECEIVER. IF PROBLEM CONTINUES, FIND WHAT CAUSED OVERCURRENT DRAW AND CYCLE POWER.
S32-S47 OUT X +VB SHORT	WHEN THE OUTPUT WAS SUPPOSED TO BE A GROUND IT HAD A POSITIVE VOLTAGE	THAT OUTPUT IS DISABLED	DETERMINE THE CAUSE OF THE SHORT, FIX THE CAUSE, AND CYCLE POWER TO RECEIVER.
S32-S47 OUT X -VB SHORT	WHEN THE OUTPUT WAS SUPPOSED TO BE A POSITIVE VOLTAGE IT HAD A GROUND	THAT OUTPUT IS DISABLED	DETERMINE THE CAUSE OF THE SHORT, FIX THE CAUSE, AND CYCLE POWER TO THE RECEIVER
A1. BOOM PSI LOW	LIFT CYLINDER PRESSURE BELOW 80 PSI	DISABLES ALL FUNCTIONS EXCEPT BOOM UP AND HOIST DOWN	HOIST DOWN LOAD IF APPLICABLE, AND RAISE BOOM OFF ANY SUPPORTS. ALARM WILL CLEAR ONCE PRESSURE IN CYLINDER IS RESTORED
A2. CW LIMIT	CRANE HAS REACHED THE LIMIT OF ROTATION IN THE CW DIRECTION	DISABLES CLOCKWISE ROTATION	ROTATE CCW TO CLEAR ERROR. ONCE SWITCH IS DEACTIVATED THE ALARM WILL CLEAR
A3. CCW LIMIT	CRANE HAS REACHED THE LIMIT OF ROTATION IN THE CCW DIRECTION	DISABLES COUNTER-CLOCKWISE ROTATION	ROTATE CW TO CLEAR ERRO. ONCE SWITCH IS DEACTIVATED THE ALARM WILL CLEAR
A4. TRK TILT WARN	TRUCK ANGLE EXCEEDS 5.7 DEGREES OR 10% SLOPE	ALL FUNCTIONS WILL ONLY OPERATE AT 50% OF SPEED	MOVE VEHICLE TO LEVEL GROUND
A5. TRK TILT ALARM	TRACK ANGLE EXCEEDS 8.5 DEGREES OR 15% SLOPE	ALL FUNCTIONS ARE DISABLED	MOVE VEHICLE TO LEVEL GROUND
A6. ANTI 2-BLOCK	ANTI 2-BLOCK IS ACTIVATED. TRAVELING BLOCK HAS COME INTO CONTACT WITH BOOM	DISABLES BOOM DOWN, EXTEND, AND HOIST UP	MOVE LOAD AWAY FROM BOOM BY EITHER RETRACTING, HOISTING DOWN, OR BOOMING UP. IF THERE IS NO LOAD NEAR TIP OF BOOM CHECK FUNCTION OF THE BAIL WELDMENT. IT MUST COME INTO CONTACT WITH SWITCH PLUNGER UNDER NORMAL CONDITIONS.
A7. 90% LOAD WARN	REACHED 90% OF RATED CAPACITY	REDUCES SPEED OF ALL FUNCTIONS BY 50%	REDUCE LOAD TO CLEAR ALARM.
A8. 100% LOAD ALARM	RACHED 100% OF RATED CAPACITY	DISABLES BOOM DOWN, EXTEND, AND HOIST UP	REDUCE LOAD BY EITHER RETRACTING, BOOMING UP, OR HOISTING DOWN.
A9. SLOW ROTATE ACT	LIFT CYLINDER HAS EXCEEDED 600 PSI	REDUCES ROTATE FUNCTIONS BY 50%	THIS IS A SAFETY FEATURE THAT PREVENTS EXCESSIVE SWINGING OF HEAVY LOADS. WILL RESET WHEN LOAD DECREASES AND FUNCTION IS DEACTIVATED
A10. BOOM SENSOR ERR	BOOM ANGLE SENSOR FAILED	ALL FUNCTIONS ARE REDUCED BY 50%	CHECK CONNECTIONS TO BOOM ANGLE SENSOR
A11. BOOM ANGLE RANGE	ANGLE SENSOR IS OUT OF RANGE	OPERATES NORMALLY	BOOM ANGLE SENSOR IS MOUNTED INCORRECTLY. CHECK MOUNTING. THE ARROW SHOULD BE FACING THE TIP OF THE CRANE.
A12. BOOM PT ERR	BOOM PRESSURE TRANSDUCER ERROR	ALL FUNCTIONS ARE DISABLED EXCEPT BOOM DOWN & HOIST DOWN	CHECK CONNECTIONS TO PRESSURE TRANSDUCER LOCATED ON LIFT CYLINDER
A13 DIRTY FILTER	FILTER IS DIRTY IF TEMPATURE OF OIL IS AT LEAST 100 DEG	OPERATES NORMALLY	REPLACE FILTER. PART NUMBER IS 366823910

# 3203EH

## ERROR CODE TROUBLESHOOTING CHART

### TETHERED UNITS ONLY

LED LABEL	COLOR	FLASH RATE	CAUSE	SOLUTION
ERROR	RED	STEADY	VEHICLE BATTERY VOLTAGE BELOW 9 VOLTS	CHECK BATTERY FLUID LEVEL. CHECK VOLTAGE DROP ACROSS POWER WIRE MAY NEED TO INCREASE WIRE SIZE VERIFY TRUCK IS RUNNING WHILE OPERATING CRANE
ANTI-2 BLOCK	RED	STEADY	HOOK/TRAVELING BLOCK CAME INTO CONTACT WITH BOOM CROWN. BOOM DOWN, EXTEND, AND HOIST UP WILL BE DISABLED	MOVE LOAD AWAY FROM BOOM BY EITHER RETRACTING, HOISTING DOWN, OR BOOMING UP. IF THERE IS NO LOAD NEAR TIP OF BOOM CHECK FUNCTION OF THE BAIL WELDMENT. IT MUST COME INTO CONTACT WITH SWITCH PLUNGER UNDER NORMAL CONDITIONS.
90% LOAD	AMBER	STEADY	CRANE REACHES 90% OF RATED CAPACITY. REDUCES SPEED OF ALL FUNCTIONS BY 50%	REDUCE LOAD TO CLEAR ALARM
100% LOAD	RED	STEADY	CRANES REACHED 100% OF RATED CAPACITY. BOOM DOWN, EXTEND, AND HOIST UP WILL BE DISABLED	REDUCE LOAD BY EITHER RETRACTING, BOOMING UP, OR HOISTING DOWN.
POWER	GREEN	STEADY	LIGHT WILL BE GREEN WHEN CRANE HAS POWER.	IF LIGHT IS NOT LIT, CHECK THE ON/OFF POWER SWITCH LOCATED IN CRANE BOX DIRECTLY UNDER CRANE.
CRANE ENABLED	GREEN	1PULSE/SEC	CRANE ENABLE "INACTIVE". NO FUNCTIONS WILL BE AVAILABLE	ACTIVATE CRANE BY TURNING ROTARY SWITCH TO START/SPEED AND RELEASE.
CAN COMMUNICATION	GREEN	OFF	NOT RECEIVING SIGNAL FROM TRANSMITTER	VERIFY TRANSMITTER IS TURNED ON CHECK TETHER CABLE FOR SECURE CONNECTION AT PENDANT AND CRANE

# 3203EH

## ELECTRICAL TROUBLESHOOTING CHART

PROBLEM	POSSIBLE CAUSE	DIAGNOSIS	SOLUTION
CRANE MOVES UNEXPECTEDLY	JAMMED TRANSMITTER BUTTON	ACTIVATE E-STOP TO SEE IF MOVEMENT STOPS	VERIFY THAT NOTHING WAS DEPRESSING THE BUTTON AT THE TIME OF MOVEMENT. IF IT WAS NOT DEPRESSED THEN REPLACE TRANSMITTER
	SHORT IN HARNESS	UNEXPECTED MOVEMENT WOULD ONLY OCCUR WHEN MULTI-FUNCTIONING. UNPLUG COIL TO SEE IF MOVEMENT STOPS. CHECK AMPERAGE TO COIL USING MULTI-METER IN LINE WITH COIL. IT SHOULD BE NO MORE THAN 100mA.	TRACE WIRE BACK TO RECEIVER. VERIFY NO DAMAGE TO THE WIRE. CHECK CONNECTORS, THEY SHOULD BE CLEAR OF DEBRIS AND WATER.
	RECEIVER LOCKED UP (FM UNITS ONLY)	BOTTOM RIGHT CORNER IS A CIRCLE WITH AN ARROW. THIS SHOULD BE ROTATING AT ALL TIMES.	IF THE ARROW STOPS ROTATING, SHUT POWER OFF TO THE CRANE. LET SET OF A COUPLE OF MINUTES AND TURN POWER BACK ON. IF THIS PROBLEM PERSISTS CONTACT TECHNICAL SUPPORT.
NO FUNCTION OPERATES ON THE CRANE.	TRANSMITTER TURNED OFF	THE STATUS LIGHT ON THE TRANSMITTER SHOULD BE FLASHING GREEN WHEN NO BUTTON IS DEPRESSED	TURN ON TRANSMITTER. FOLLOW DE-ACTIVATING E-STOP PROCEDURES ON PAGE 3-3.0
	E-STOP ACTIVE	CHECK LCD SCREEN. YOU WOULD HAVE AN ERROR STATING E-STOP IS ACTIVE (FM UNITS) CRANE ENABLE LIGHT WILL BE BLINKING AT 1 PULSE/SECOND	TURN ON TRANSMITTER. FOLLOW DE-ACTIVATING E-STOP PROCEDURES ON PAGE 3-3.0
	RECEIVER TURNED OFF	CHECK THE LCD SCREEN. IF IT IS BLANK, THE RECEIVER IS TURNED OFF (FM UNITS). POWER LIGHT WILL BE OFF. (TH UNITS)	CHECK MAIN POWER SWITCH LOCATED IN CRANE BOX DIRECTLY UNDER THE CRANE.
	LOW BATTERY	WHILE THE TRANSMITTER IS TURNED ON, CHECK THE LCD SCREEN ON RECEIVER. BATTERY INDICATOR SHOULD BE AT LEAST 10% (FM UNITS)	REPLACE TRANSMITTER BATTERIES. IT REQUIRES (2) AA BATTERIES
	RECEIVER LOCKED UP (FM UNITS ONLY)	BOTTOM RIGHT CORNER IS A CIRCLE WITH AN ARROW. THIS SHOULD BE ROTATING AT ALL TIMES. (FM UNITS)	IF THE ARROW STOPS ROTATING, SHUT POWER OFF TO THE CRANE. LET SET OF A COUPLE OF MINUTES AND TURN POWER BACK ON. IF THIS PROBLEM PERSISTS CONTACT TECHNICAL SUPPORT.
	TRUCK TILT ALARM ACTIVE (FM UNITS ONLY)	CHECK SCREEN FOR ERROR CODE. IT WOULD READ TRK TILT ALARM (FM UNITS)	THIS ERROR OCCURS WHEN THE TRUCK ANGLE EXCEEDS A 15 % SLOPE (8.5 DEGREES). RELOCATE THE TRUCK TO A FLATTER SURFACE.
	POWER UNIT NOT ACTIVATING	IF RECEIVER HAS POWER BUT THE POWR UNIT DOESN'T TURN ON WHEN A FUNCTION IS SELECTED	CHECK POWER UNIT RELAY CHECK GROUNDING WIRE FROM RELAY TO PUMP CHECK MAIN GROUNDING WIRE FROM PUMP TO GROUNDING BOLT ON PEDESTAL
THE FOLLOWING FUNCTIONS ARE INOPERABLE BOOM DOWN, EXTEND, HOIST UP	ANTI-2 BLOCK	CHECK SCREEN FOR ERROR CODE. IT WOULD READ ANTI-2 BLOCK ERROR. (FM UNITS) ANTI-2 BLOCK LED WOULD BE STEADY RED (TH UNITS)	VERIFY THAT THE TRAVELING BLOCK IS NOT IN CONTACT WITH BAIL. IF SO, HOIST DN AND CHECK FUNCTIONS AGAIN. INSPECT END OF BOOM TO VERIFY BAIL IS IN CONTACT WITH ANTI-2 BLOCK SWITCH. CHECK BAIL SPRING. CHECK CORD REEL & WIRE ON SIDE OF CRANE FOR DAMAGE.
	CRANE OVERLOAD	CHECK SCREEN FOR ERROR CODE. IT WOULD READ 100% OVERLOAD. (FM UNITS) 100% LOAD LED WOULD BE STEADY RED (TH UNITS)	VERIFY LOAD ON CRANE DOES NOT EXCEED MOMENT RATING. REFERENCE LOAD CHART. TAP HOIST DOWN OR RETRACT FUNCTION TO RESET OVERLOAD. CHECK OPERATION AGAIN. CHECK WIRING TO PRESSURE SWITCH. VERIFY SWITCH IS PLUGGED INTO HARNESS. (TH ONLY)
THE FOLLOWING FUNCTIONS ARE INOPERABLE EXTEND, RETRACT, HOIST UP, BOOM UP, ROTATE CW, & ROTATE CCW	LOW BOOM PRESSURE (FM UNITS ONLY)	CHECK SCREEN FOR ERROR CODE, IT WOULD READ BOOM PSI LOW	VERIFY BOOM IS NOT SUPPORTED BY ANYTHING EXCEPT THE LIFT CYLINDER. THIS WOULD INCLUDE THE BOOM SUPPORT ON THE VEHICLE.

# 3203EH

## ELECTRICAL TROUBLESHOOTING CHART

PROBLEM	POSSIBLE CAUSE	DIAGNOSIS	SOLUTION
ALL FUNCTIONS ARE INOPERABLE EXCEPT BOOM DOWN AND HOIST DOWN (FM UNITS ONLY)	PESSURE TRANSDUCER IS UNPLUGGED (FM UNITS)	CHECK LCD SCREEN. IT WOULD READ "BOOM PT ERROR"	VERIFY THAT PRESSURE TRANSDUCER LOCATED ON THE LIFT CYLINDER VALVE BLOCK IS PLUGGED INTO THE HARNESS
CRANE ROTATES SLOWLY	SLOW ROTATE ACTIVATED (FM UNITS ONLY)	CHECK LCD SCREEN. IT WOULD READ "SLOW ROTATE ACT"	THIS IS A SAFETY FEATURE TO PREVENT GETTING THE LOAD INTO AN UNSAFE CONDITION (EXCESSIVE SWINGING). SLOW ROTATE WILL REMAIN ACTIVE UNTIL THE LOAD IS REMOVED AND THE ROTATION FUNCTION IS DESELECTED.
	CLOSE TO MAX CRANE LOAD	WHEN THE TRUCK IS TILTED AND UNDER HIGH LOAD A DECREASE IN SPEED IS POSSIBLE	BRING LOAD IN CLOSER TO DECREASE THE LOAD
	ADEQUATE OPERATING CLEARANCES BETWEEN WORM GEAR AND WORM	ROTATION WILL SLOW AT A PARTICULAR POINT ON THE WORM GEAR	SLIGHTLY LOOSEN BOLTS ATTACHING TAPERED BEARINGS TO PEDESTAL. TAP THE BEARING HOUSING USING A HAMMER AWAY FROM THE WORM GEAR. RETIGHTEN BOLTS.
ALL FUNCTIONS OPERATE SLOWLY	WRONG SPEED FUNCTION IS SELECTED	CHECK THE TRANSMITTER. THERE SHOULD BE A GREEN LED DIRECTLY BELOW THE CURRENT SPEED SELECTED.	ADJUST THE SPEED TO THE PREFERRED SPEED SETTING. REFERENCE SPEED CONTROL SECTION ON PAGE 3-3.0
	BOOM ANGLE SENSOR ERROR (FM UNITS ONLY)	CHECK SCREEN FOR ERROR CODE. IT WOULD READ "BOOM SENSOR ERR"	VERIFY THAT THE BOOM SENSOR IS PLUGGED INTO THE HARNESS. CHECK CONNECTION BETWEEN HARNESS AND SENSOR. REMOVE ANY DEBRIS OR WATER FROM CONNECTOR AND REATTACH.
	90% OVERLOAD ACTIVATED	CRANE IS AT OR OVER 90% OF IT'S RATED CAPACITY	THIS IS A SAFETY FEATURE TO PREVENT GETTING INTO AN UNSAFE CONDITION (SUDDEN MOVEMENT OF HEAVY LOAD). 90% OVERLOAD WILL REMAIN ACTIVATED UNTIL LOAD IS DECREASED.
	TRUCK TILT WARNING (FM UNITS ONLY)	CRANE IS BETWEEN A 10% AND 15% SLOPE. CHECK LCD SCREEN FOR ERROR CODE, IT WOULD READ "TRK TILT WARN"	MOVE VEHICLE OR RAISE OUTRIGGER TO A MORE STABLE, LEVEL POSITION.
	LOW VOLTAGE	VOLTAGE WILL BE 10 VOLTS OR LOWER	VERIFY TRUCK IS RUNNING WHILE OPERATING CRANE CHECK VEHICLE BATTERY FLUID LEVEL CHECK FOR ADEQUATE WIRE SIZING FOR LENGTH AND AMPERAGE REQUIREMENTS



# 3203EH

## HYDRAULIC TROUBLESHOOTING CHART

PROBLEM	POSSIBLE CAUSE	DIAGNOSIS	SOLUTION
CRANE MOVES UNEXPECTEDLY	JAMMED CARTRIDGE	TRY TO MANUALLY OVERRIDE VALVE IF UNABLE TO MOVE STEM. CARTRIDGE IS JAMMED	REPLACE CARTRIDGE
	COUNTER-BALANCE SET TOO LOW (BOOM-UP & BOOM-DN )	ADJUST THE COUNTER-BALANCE OUT TO SEE IF MOVEMENT STOPS.	CONTACT AUTOCRANE FOR PROPER SETTING OF COUNTER-BALANCE. YOU MAY NEED TO REPLACE COUNTER-BALANCE.
	CONTAMINATE IN CARTRIDGE	VALVE STICKS IN CERTAIN POSITIONS	REFERENCE PG. 9-8 FOR CLEANING PROCEDURE
NO FUNCTION OPERATES ON CRANE	HYDRAULIC TANK IS LOW OR EMPTY	VISUALLY INSPECT THE HYDRAULIC OIL LEVEL IN THE TANK	FILL TANK TO PROPER LEVEL.
	VEHICLE IS NOT RUNNING	VERIFY ENGINE IS RUNNING	START VEHICLE
ALL FUNCTIONS OPERATE SLOWLY	FILTER CLOGGED	IF NEXSTAR II, CHECK LCS SCREEN. IF NEXSTAR I, CHECK FILTER	REPLACE FILTER
EXCESSIVE HEAT DURING OPERATION	OPERATION TIME	CRANE OPERATION IS GENERALLY DESIGNED FOR INTERMITTENT DUTY (7 MIN. LOADED / 30 MIN. COOLDOWN)	REDUCE USE OF CRANE TO ALLOW OIL TO COOL

# 3203EH CARTRIDGE MAINTENANCE

- Clean the area around the valve spool to be removed from the valve bank
- Remove the valve spool from the valve bank being careful not to touch or hit surrounding objects
- Carefully remove any visible debris from the valve spool
- The recommended cleaning fluid is off-the-shelf automotive brake cleaning fluid.
- It is recommended the skin and eye protection be worn when spraying the valve spool clean.
- Inspect o-rings for damage and replace if needed
- Dip the valve spool into fresh hydraulic oil to lubricate and fill cavities
- Reinstall the valve spool in the reverse order in which it was removed
- Validate function operation of the crane



VERIFY MOVEMENT IN PORTS WHILE  
MANUALLY OVER-RIDING CARTRIDGE.

# 3203EH LOAD CHART

## P/N 320988005

**3203PR**  
**3203PRX**  
**3203H**

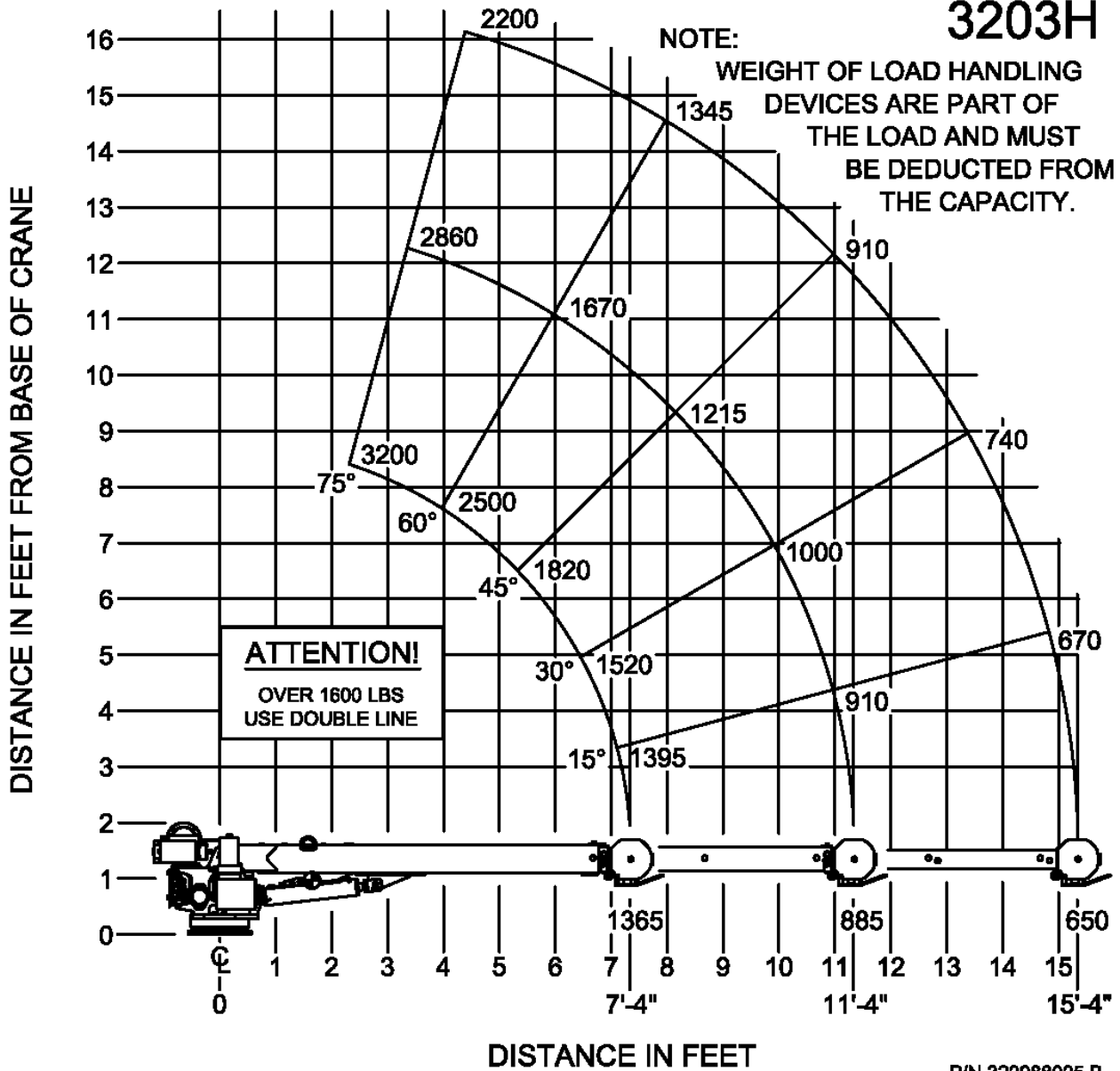

P/N 320988005 B



P.O. Box 580697 \* Tulsa, OK 74158-0697  
4707 N. Mingo Rd. \* Phone (918) 438-2760

## LIMITED WARRANTY 1 YEAR PURCHASED REPLACEMENT PARTS

Auto Crane will warranty to the consumer for a period of (1) year from the date that a new Auto Crane replacement part was purchased from an authorized Auto Crane distributor. Each new Auto Crane part they sell will be free under normal use and service from defects in material and workmanship. Date of purchase will be honored as the date indicated on the Bill of Sale to the consumer.

The obligation of Auto Crane under this warranty does not apply to parts replaced under the limited warranty for a new Auto Crane product. The warranty for parts replaced under the limited warranty of a new Auto Crane product expires when the warranty for that product expires.

The obligation of Auto Crane under this warranty is limited to the replacement or repair of purchased replacement parts that appear to the manufacturer to be defective after review of documentation (Auto Crane Warranty Claim Form, photos, data, etc.) provided by the Auto Crane distributor and/or inspection of parts returned to Auto Crane. This warranty does not obligate Auto Crane to bear labor costs to replace the defective parts or travel time charges in connection with the replacement or repair of defective parts. Responsibility for customer's claims arising from misapplication, abuse, misuse or alteration of equipment or parts lies with the distributor or user and no warranty obligation is assumed in these circumstances by Auto Crane.

Auto Crane will in no event be liable for any consequential damages or contingent liabilities arising out of the failure of any Auto Crane product or parts to operate properly.

Auto Crane makes no warranty in respect to parts for component accessories, it being subject to the warranties of their respective manufacturers.

If field service, at the request of the distributor, is rendered and fault is found not to be with Auto Crane's product, the distributor shall pay the time and expense of the field representative.

Claims for service labor or other expenses that have incurred by the buyer without approval or authorization or Auto Crane will not be accepted.

When applying for warranty, claims may be handled by contacting your nearest authorized Auto Crane **Distributor**. **All claims are to be filed in writing on an Auto Crane Warranty Claim Form.**



P.O. Box 580697 \* Tulsa, OK 74158-0697  
4707 N. Mingo Rd. \* Phone (918) 836-0463

## LIMITED WARRANTY 2 YEAR PARTS AND LABOR

Auto Crane will warranty to the consumer for a period of (2) years parts and labor from the date of purchase. Each new Auto Crane unit they sell will be free under normal use and service from defects in material and workmanship. Date of purchase will be honored as the date indicated on the Bill of Sale, which must accompany the Warranty Registration and be on file with Auto Crane. Absent a valid Warranty Registration and appropriate documentation, the original date of manufacture, as indicated by the serial number on the product, will be used to determine the effective date of the 2 year warranty.

The obligation of Auto Crane under this warranty is limited to the replacement or repair of parts that appear to the manufacturer after review and/or inspection to be defective and paid flat rate labor for replacing defective parts. This warranty does not obligate Auto Crane to bear the travel time charges in connection with the replacement or repair of defective parts. Responsibility for customer's claims arising from misapplication, abuse, misuse or alteration of equipment or parts lies with the distributor or user and no warranty obligation is assumed in these circumstances by Auto Crane.

Auto Crane will in no event be liable for any consequential damages or contingent liabilities arising out of the failure of any Auto Crane Product or parts to operate properly.

Auto Crane makes no warranty in respect to component accessories, it being subject to the warranties of their respective manufacturers.

If field service, at the request of the distributor, is rendered and fault is found not to be with Auto Crane's product, the distributor shall pay the time and expense of the field representative.

Claims for service labor or other expenses that have incurred by the buyer without approval or authorization or Auto Crane will not be accepted.

When applying for warranty, claims may be handled by contacting your nearest authorized Auto Crane **Distributor**. **All claims are to be filed in writing on an Auto Crane Warranty Claim Form.**

**AUTO CRANE COMPANY IS UNDER NO OBLIGATION TO EXTEND THIS WARRANTY TO ANY CUSTOMER FOR WHICH AN AUTO CRANE DELIVERY REPORT FORM HAS NOT BEEN COMPLETED AND ON FILE WITH AUTO CRANE COMPANY**