



14005HP

OWNERS MANUAL

SPECIAL: HELMERICH & PAYNE

Manual No. 470098000
Rev.9/07/06

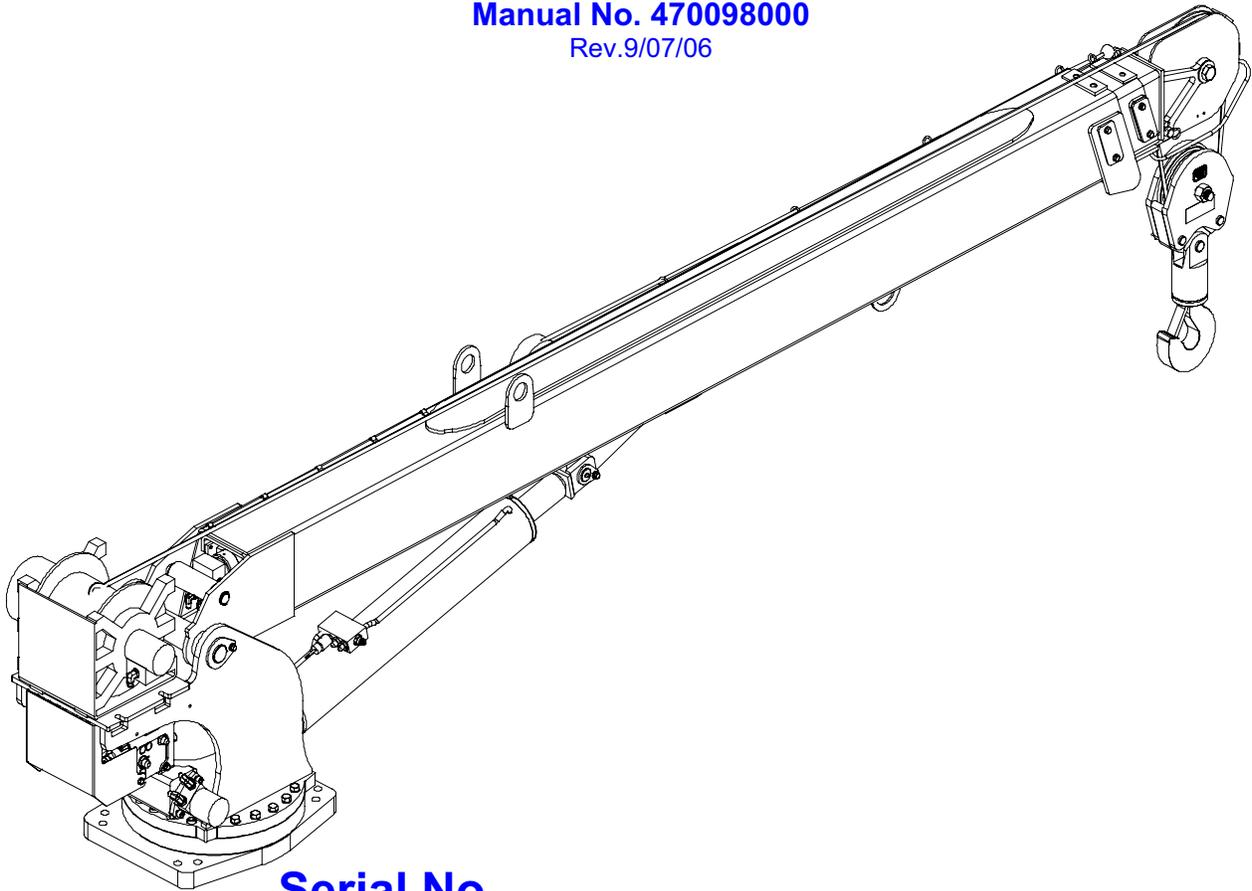

Serial No. _____

Mailing Address:
P.O. Box 580697
Tulsa, OK 74158-0697
Physical Address:
4707 N. Mingo Rd.
Tulsa, OK 74117-5904

Phone (918) 836-0463
Fax (918) 834-5979
<http://www.autocrane.com>



Auto Crane Warranty Registration

Fax Transmission

To: Warranty Department Fax: (918) 834-5979
 From: _____ Date: _____
 Re: Product Registration Pages: _____

End User Information: (Required for Warranty Activation)

Name: _____ Phone: _____
 Address: _____
 City: _____ State: _____ Zip: _____
 Contact: _____ E-mail Address: _____

Distributor Information: (Required for Warranty Activation)

Name: _____
 Address: _____
 City: _____ State: _____ Zip: _____
 Contact: _____ E-mail Address: _____

Product Information: (Required for Warranty Activation)

Model No.: _____ Serial No.: _____
 Date Product Delivered: _____ Date Processed:* _____
 VIN # _____ * For Auto Crane use only

ONE REGISTRATION FORM PER UNIT (CRANE OR BODY)

Registration form must be mailed or faxed within 15 days of customer installation.

Mail to:
 Warranty Department
 Auto Crane Company
 P.O. Box 581510
 Tulsa, OK 74158-0697

WARNINGS

WARNING! Federal law (49 cfr part 571) requires that the Final Stage Manufacturer of a vehicle certify that the vehicle complies with all applicable federal regulations. Any modifications performed on the vehicle prior to the final state are also considered intermediate stage manufacturing and must be certified as to compliance. The installer of this crane and body is considered one of the manufacturers of the vehicle. As such a manufacturer, the installer is responsible for compliance with all applicable federal and state regulations, and is required to certify that the vehicle is in compliance.

WARNING! It is the further responsibility of the installer to comply with the OSHA Truck Crane Stability Requirements as specified by 29 CFR part 1910.180 (C) (1).

WARNING! NEVER OPERATE THE CRANE NEAR ELECTRICAL POWER LINES!

Death or serious injury will result from boom, line, or load contacting electric lines. Do not use crane within 10 feet (3.05m) of electric power lines carrying up to 50,000 volts. One-foot additional clearance is required for every additional 30,000 volts or less. **SEE DANGER DECAL (P/N 040529)** in this Owner's Manual.

WARNING! NEVER.....

- ◆ **EXCEED** load chart capacities (centerline of rotation to hoist hook).
- ◆ Un-reel last 5 wraps of cable from drum!
- ◆ Wrap cable around load!
- ◆ Attempt to lift or drag a load from the side! The boom can fail far below its rated capacity.
- ◆ Weld, modify, or use unauthorized components on any Auto Crane unit! This will void any warranty or liability. Also failure of the crane may result.
- ◆ Place a chain link on the tip of the hook and try to lift a load!
- ◆ Use a sling bar or anything larger than the hook throat that could prevent the hook latch from closing, thus negating the safety feature!
- ◆ Hold on any pendant Select Switch that will cause unsafe operating conditions!

WARNING! In using a hook with latch, **ALWAYS** make sure that the hook throat is closed before lifting a load! Proper attention and common sense applied to the use of the hoist hook and various slings will prevent possible damage to material being hoisted and may prevent injury to personnel.

WARNING! Failure to correctly plumb and wire crane can cause inadvertent operation and damage to crane and/or personnel!

WARNING! Auto Crane Company remote controlled cranes are not designed or intended for use for any applications involving the lifting or moving of personnel.

WARNING! ALWAYS operate the crane in compliance with the load capacity chart. **DO NOT USE** the overload shutdown device to determine maximum rated loads, if the crane is equipped with this type of device.

READ THIS PAGE

14005H

TABLE OF CONTENTS

INTRODUCTION	1-1.0
GENERAL SPECIFICATIONS	1-3.0
SAFETY TIPS AND PRECAUTIONS	2-1.0
OPERATING PRACTICES & WARNINGS	2-3.0
QUALIFICATIONS FOR OPERATORS	2-4.0
OPERATION OF UNIT / OUTRIGGERS	2-7.0
INSPECTION	3-1.0
TESTING	3-4.0
MAINTENANCE	3-5.0
BATTERIES	3-7.0
LUBRICATION AND MAINTENANCE SCHEDULE	3-9.0
SAFETY DECAL SECTION	4-1.0
GENERAL DIMENSIONS	5-1.0
MOUNTING AND INSTALLATION	5-2.0
GENERAL ASSEMBLY, HARDWIRED	6-1.0
PEDESTAL ASSEMBLY, HARDWIRED	6-3.0
BOOM ASSEMBLY	6-7.0
ROTATION GEARBOX	6-9.0
TRAVELING BLOCK ASSEMBLY	6-14.0
ELECTRICAL SECTION, HARDWIRED	7-1.0
MAIN WIRING HARNESS	7-2.0
JUNCTION BOX	7-3.0
PENDANT ASSEMBLY	7-5.0
PENDANT CABLE ASSEMBLY	7-7.0
PROPORTIONAL VALVE	7-8.0
HYDRAULIC SECTION	8-1.0
LOAD CHART	12-1.0
WARRANTY	13-1.0
DP WINCH SECTION	APPENDIX

14005H INTRODUCTION

Auto Crane products are designed to provide many years of safe, trouble-free, dependable service when properly used and maintained.

To assist you in obtaining the best service from your crane and to avoid untimely crane and/or vehicle failure, this manual provides the following operating and service instructions. It is specifically recommended that all operating and service personnel consider this manual as mandatory material for reading and study before operating or servicing Auto Crane products. It is highly recommended that crane owners, equipment managers, and supervisors also read this manual.

Auto Crane has incorporated several safety features in the 14005H crane for your protection.

For your convenience the overall dimensions of the 14005H crane are included on the General Dimension Drawing. Rotation and turning radius are also listed on that drawing.

Remember, the crane adds weight to the vehicle. Adding weight may change the driving and riding characteristics of the vehicle unless the appropriate overload spring(s) are installed on the truck. The payload of the vehicle is reduced by the weight of the crane. The operator should exercise care when loading the vehicle. Distributing the payload on the vehicle evenly will greatly improve the driving and riding characteristics of the vehicle.

Auto Crane Company issues a limited warranty certificate with each unit sold. See last page for warranty.

The 14005H cranes are attached to your 12-volt truck electrical system through the relay provided. The 14005H is another highly efficient Auto Crane product. The use of a maintenance-free battery is not recommended on any Auto Crane product. The recommended alternator and battery

that will give the longest life with the most useful duty cycle is a 60-amp alternator with a 500 cold cranking amp battery. These specifications should be considered minimum.

It has always been Auto Crane Company policy to handle all warranty claims we receive as promptly as possible. If a warranty claim involves discrepant material or workmanship, Auto Crane will take immediate corrective action. It is understandable that Auto Crane Company cannot assume responsibility of liability when it is obvious that our products have been abused, misused, overloaded or otherwise damaged by inexperienced persons trying to operate the equipment without reading the manual.

Auto Crane will not assume responsibility or liability for any modifications or changes made to unit, or installation of component parts without authorization.

Auto Crane maintains a strong distributor network and a knowledgeable Customer Service Department. In most cases, an equipment problem is solved via phone conversation with our customer service department. The customer service department also has the ability to bring a local distributor, a regional sales manager, or a factory serviceman into the solution of an equipment problem.

If, through no fault of Auto Crane Company, it is necessary to send an experienced factory serviceman on a field service call the rates stated in the Auto Crane Distributor's Flat Rate Manual will apply.

Auto Crane Company's extensive Research and Development Program allow our customers to use the best equipment on the market. Our Engineering Staff and our knowledgeable sales people are always available to our customers in solving crane and winch-type application problems. When in doubt, call the Auto Crane factory.

Note: This manual should remain with the crane at all times.

14005H INTRODUCTION

DISTRIBUTOR ASSISTANCE:

Should you require any assistance not given in this manual, we recommend that you consult your nearest Auto Crane Distributor. Our distributors sell authorized parts and have service departments that can solve almost any needed repair. This manual does not cover all maintenance, operating, or repair instructions pertinent to all possible situations. **If you require additional information, please contact the Auto Crane Company at the following telephone number: (918) 836-0463.** The information contained in the manual is in effect at the time of this printing. Auto Crane Company reserves the right to update this material without notice or obligation.

14005H

GENERAL SPECIFICATIONS

DIMENSIONS

Width: 27 in (.69 m)
Height: 39 in (.99 m)
Length: 15 ft 9 in (4.80 m)
 [Boom(s) stored]
Weight: 3,200 lbs (1,451 kg)

CAPACITY

78,000 ft-lbs (9.68 ton-m)
 [ft-lbs = horizontal distance from centerline of rotation to free hanging weight (feet) x amount of weight (pounds)]

LIFTING CAPACITIES			
ft	lbs	ft	lbs
3	14,000	17	4,588
4	14,000	18	4,333
5	14,000	19	4,105
6	13,000	20	3,900
7	11,143	21	3,714
8	9,750	22	3,545
9	8,667	23	3,391
10	7,800	24	3,250
11	7,091	25	3,120
12	6,500	26	3,000
13	6,000	27	2,889
14	5,571	28	2,786
15	5,200	29	2,690
16	4,875	30	2,600

REACH

Second boom will reach from 13 feet to 22 feet 2 inches.
 Third boom will reach from 22 feet 2 inches to 30 feet.

CABLE

120 ft (36.6 m) of 1/2 in (12.7 mm) diameter aircraft quality cable. This cable has a single line breaking strength of 26,600 lbs (12,065 kg).

CHASSIS REQUIREMENTS

29,000 lbs (13,154 kg) GVWR minimum
 1,000,000 in-lbs RBM

ELECTRICAL SYSTEM REQUIREMENTS

Voltage: 12 VDC
Alternator: 60 amp (minimum)
Battery: 100 minute reserve capacity (minimum)
 Maintenance type

ROTATION

370° Rotation with electric stop.

--- IMPORTANT ---

SAFETY TIPS AND PRECAUTIONS

1. No unqualified or unauthorized person shall be allowed to operate the crane.
2. **WARNING:** Never weld, modify, or use unauthorized components / parts on any Auto Crane unit. This will void any warranty or liability. Also, failure of the crane may result.
3. Make certain the vehicle meets minimum chassis requirements. (These requirements do not guarantee unit stability.)
4. Make certain the crane is installed per factory specifications. Contact your local distributor or the Auto Crane factory if any questions arise.
5. Visual inspections and tests should be conducted at the beginning of each shift each day to insure that the crane and all its operating systems are in good condition and working order before it is used.
6. Inspect hydraulic hoses frequently for signs of deterioration, and replace them as required.
7. If a hydraulic break occurs, leave the area of the break and do not attempt to stop the break by hand as the hydraulic oil may be hot and under high pressure which can cause serious injury. Shut the system down as soon as possible.
8. Check the hook at least every thirty days for distortions or cracks and replace it as required.
9. Oil gears as required.
10. Stop all operations when cleaning, adjusting or lubricating the machine.
11. Keep dirt and grit out of moving parts by keeping crane clean. Make sure machine is free of excess oil, grease, mud and rubbish, thus reducing accidents and fire hazards.
12. When a new cable is installed, operate first with a light load to let the cable adjust itself.
13. Locate the vehicle at the work site for the best stability possible.
14. Keep the vehicle in a level position while loading or unloading.
15. Observe operating area for obstructions and/or power lines that might be a hazard.
16. **WARNING: NEVER OPERATE THE CRANE NEAR ELECTRICAL POWER LINES.** Auto Crane Company recommends that the crane never be any closer to a power line (including telephone lines) than 10 feet at any point.
17. Allow the vehicle engine to warm up before operating crane.
18. Know the weight of your rigging and load to avoid overloading the crane.
19. Deduct the weight of the load handling equipment from the load rating to determine how much weight can be lifted.
20. All load ratings are based on crane capacity, NOT the vehicle stability. Remember in lifting a heavy load, the weight can create enough tipping moment to overturn the vehicle
21. Always comply with load chart capacities, (centerline of rotation to hook).
22. Secure all loads before lifting.
23. Always set the emergency brake before beginning operation.
24. Keep objects and personnel clear of crane path during operation.
25. Operate control levers slowly and smoothly in order to meter oil flow for safe operation.
26. Always extend the outriggers from vehicle to the ground before crane operation. Insure that they are firmly positioned on solid footings. Stand clear of outriggers while they are being extended.
27. If any outrigger, when extended, rests on a curb or other object that prevents it from extending to its maximum distance, shorten bearing or fulcrum point and reduce the maximum load accordingly.
28. When an outrigger will not reach the ground due to holes or grades, it shall be blocked up to provide level and firm support for the truck.
29. When working in soft earth, use wide pads under outrigger feet to prevent sinking.
30. Always store outriggers before transportation.

WARNING!

Auto Crane Company cranes are not designed or intended for use in lifting or moving persons. Any such use shall be considered to be improper and the seller shall not be responsible for any claims arising there from. This sale is made with the express understanding that there is no warranty that the goods shall be fit for the purpose of lifting or moving persons or other improper use and there is no implied warranty or responsibility for such purposes.

--- IMPORTANT ---

SAFETY TIPS AND PRECAUTIONS

31. Always store the crane in its stowed position for transportation.
32. Remember the overall height of the entire unit for garage door clearance or when moving under objects with low overhead clearance
33. Disengage power takeoff (PTO) before moving the vehicle.
34. Always walk around the vehicle before moving.
35. Never drive with a load suspended from crane.
36. Do not take your eyes off a moving load. Look in the direction you are moving.
37. Never swing a load over people.
38. Do not stop the load sharply in midair so that it swings like a pendulum. Meter the control levers to avoid this situation.
39. Crane boom length should be kept as short as possible for maximum lifting capacity and greater safety. Longer booms require additional care in accelerating and decelerating the swing motion, and thus slow down the working cycle and reduce productivity.
40. Keep the load directly and vertically under the boom point at all times. Crane booms are designed to handle vertical loads, not side lifts.
WARNING: Never attempt to lift, drag, tow or pull a load from the side. The boom can fail far below its rated capacity.
41. Do not push down on anything with boom extensions; similarly do not lift anything with boom extensions.
42. Do not lift personnel with any wire rope attachment or hook. There is no implied warranty or responsibility for such purposes.
43. **WARNING:** In using a safety hook, ALWAYS close the hook throat before lifting a load. Proper attention and common sense applied to the use of the hook and various slings will prevent possible damage to material being hoisted and may prevent injury to personnel.
44. **WARNING:** Never place a chain link on the tip of the hook and try to lift a load with the hoist.
45. **WARNING:** Never use a sling bar or anything larger than the hook throat which could prevent the safety latch from closing, thus negating the safety feature.
46. Do not wrap the wire rope around sharp objects when using winch.
47. **WARNING:** Never unreel last 5 wraps of cable from drum.

--- IMPORTANT ---

OPERATING PRACTICES AND WARNINGS

1. Make certain the vehicle meets minimum chassis requirements. (These requirements do not guarantee unit stability)
2. Make certain the crane is installed per factory specifications. Contact your local Distributor or the Auto Crane factory if any questions arise.
3. Keep the vehicle in as level a position as possible while loading or unloading.
4. **ALWAYS** set the vehicle emergency brake before beginning crane operations.
5. **ALWAYS** use outriggers from vehicle to the ground during crane operation. Make sure they are firmly positioned on solid footings.
6. All load ratings are based on crane capacity, **NOT** truck/crane stability.
7. Keep objects and personnel clear of crane path during operation.
8. Keep hoist cable pulled tight at all times.
9. **REMEMBER**, in lifting a heavy load, the weight can create enough tipping momentum to overturn the vehicle.
10. **ALWAYS** keep load as close to ground as possible.
11. Hydraulic hoses need to be inspected frequently for signs of deterioration, and be replaced as required.
12. The hoist hook is an important item that an operator should consider and use properly. It should be checked on a daily basis for distortion or cracks.
13. **ALWAYS** store outriggers before road travel.
14. **WARNING! NEVER OPERATE THE CRANE NEAR ELECTRICAL POWER LINES!** Death or serious injury will result from boom, line, or load contacting electric lines. Do not use crane within 10 feet (3.05m) of electric power lines carrying up to 50,000 volts. One foot additional clearance is required for every additional 30,000 volts or less.
15. **WARNING! NEVER EXCEED** load chart capacities (centerline of rotation to hoist hook).
16. **WARNING! NEVER** un-reel last 5 wraps of cable from drum!
17. **WARNING! NEVER** wrap cable around load!
18. **WARNING! NEVER** attempt to lift or drag a load from the side! The boom can fail far below its rated capacity.
19. **WARNING! NEVER** weld, modify, or use unauthorized components on any Auto Crane unit! This will void any warranty or liability. Also failure of the crane may result.
20. **WARNING! NEVER** place a chain link on the tip of the hook and try to lift a load!
21. **WARNING! NEVER** use a sling bar or anything larger than the hook throat that could prevent the hook latch from closing, thus negating the safety feature!
22. **WARNING!** In using a hook with latch, **ALWAYS** insure that the hook throat is closed before lifting a load! Proper attention and common sense applied to the use of the hoist hook and various slings will prevent possible damage to material being hoisted and may prevent injury to personnel.
WARNING! NEVER hold any Control Select Switch on that will cause unsafe operating conditions!

WARNING!

Auto Crane Company remote controlled, stiff boom cranes are not designed or intended for use on any applications involving the lifting or moving of personnel.

QUALIFICATIONS FOR AND CONDUCT OF OPERATORS AND OPERATING PRACTICES

REFERENCE ASME B30.5a AND OSHA 1910.180 FOR COMPLETE QUALIFICATION REQUIREMENTS

OPERATORS

1. Crane operation shall be limited to personnel with the following minimum qualifications:
 - A. Designated persons.
 - B. Trainees under the direct supervision of a designated person.
 - C. Maintenance and test personnel (when it is necessary in the performance of their duties).
 - D. Inspectors (crane).
2. No one other than the personnel specified above shall enter the operating area of a crane with the exception of persons such as oilers, supervisors, and those specified persons authorized by supervisors whose duties require them to do so and then only in the performance of their duties and with the knowledge of the operator or other persons.

QUALIFICATIONS FOR OPERATORS

1. Operators shall be required by the employer to pass a practical operating examination. Qualifications shall be limited to the specific type of equipment for which examined.
2. Operators and operator trainees shall meet the following physical qualifications:
 - A. Vision of at least 20/30 Snellen in one eye and 20/50 in the other, with or without corrective lenses.
 - B. Ability to distinguish colors, regardless of position, if color differentiation is required for operation.
 - C. Adequate hearing with or without hearing aid for the specific operation.
3. Evidence of physical defects or emotional instability, which render a hazard to operator or others, which in the opinion of the examiner could interfere with the operator's performance, may be sufficient cause for disqualification. In such cases, specialized clinical or medical judgment and tests may be required.
4. Evidence that operator is subject to seizures or loss of physical control shall be sufficient reason for disqualification. Specialized medical

tests may be required to determine these conditions.

5. Operators and operator trainees should have normal depth perception, coordination, and no tendencies to dizziness or similar undesirable characteristics.
6. In addition to the above listed requirements, the operator shall:
 - A. Demonstrate the ability to comprehend and interpret all labels, operator's manuals, safety codes, and other information pertinent to correct crane operations.
 - B. Posses the knowledge of emergency procedures and implement it.
 - C. Demonstrate to the employer the ability to operate the specific type of equipment.
 - D. Be familiar with the applicable safety regulations.
 - E. Understand the operating procedures as outlined by the manufacturer.
 - F. Be thoroughly familiar with the crane and its control functions.
 - G. Understand the operating procedures as outlined by the manufacturer.

CONDUCT OF OPERATORS

1. The operator shall not engage in any practice, which will divert his attention while actually operating the crane.
2. Each operator shall be responsible for those operations under the operator's direct control. Whenever there is any doubt as to safety, the operator shall consult with the supervisor before handling the loads.
3. The operator should not leave a suspended load unattended unless specific precautions have been instituted and are in place.
4. If there is a warning sign on the switch or engine starting controls, the operator shall not close the switch or start the engine until the warning sign has been removed by the appointed person.
5. Before closing the switch or starting the engine, the operator shall see that all controls are in the "OFF"

QUALIFICATIONS FOR AND CONDUCT OF OPERATORS AND OPERATING PRACTICES

- or neutral position and all personnel are in the clear.
6. If power fails during operation, the operator shall:
 - A. Move power controls to the "OFF" or neutral position.
 - B. Land the suspended load and boom, if practical.
 7. The operator shall be familiar with the equipment and its proper care. If adjustments or repairs are necessary, the operator shall report the same promptly to the appointed person, and shall also notify the next operator.
 8. The operator at the start of each shift shall test all controls. If any controls do not operate properly, they shall be adjusted or repaired before operations are begun.
 9. Stabilizers shall be visible to the operator while extending or setting unless a signal person assists operator.
- C. Means are provided to hold the vehicle stationary while operating the crane.
 - D. Before starting to lift, the hook shall be positioned over the load in such a manner as to minimize swinging.
 - E. During lifting care shall be taken that:
 1. There is no sudden acceleration or deceleration of the moving load.
 2. Load, boom or other parts of the crane do not contact any obstruction.
 - F. Cranes shall not be used for dragging loads sideways.
 - G. This standard recognizes that telescopic boom cranes are designed and intended for handling materials. They do not meet personnel lift or elevator requirements. Therefore, no lifting, lowering, swinging or traveling shall be done while a person is on the hook or load. Hook attached suspended work platforms (baskets) shall not be used with cranes covered by this standard. Crane manufacturer must approve work platforms attached to the boom.
 - H. The operator should avoid carrying loads over people.
 - I. When the crane is so equipped, the stabilizers shall be fully extended and set. Blocking under stabilizers shall meet the requirements as follows:
 1. Strong enough to prevent crushing.
 2. Of such thickness, width and length as to completely support the stabilizer pad.
 - J. Firm footing under all tires, or individual stabilizer pads should be level. Where such a footing is not otherwise supplied, timbers, cribbing, or other structural members to distribute the load so as to not exceed allowable bearing capacity or the underlying material should provide it.
 - K. In transit, the boom shall be carried in stowed position.
 - L. When rotating the crane, sudden starts and stops shall be avoided. Rotational speed shall be such that the load does not swing out beyond the radius at which it can be controlled.
 - M. The crane shall not be transported with a load on the hook unless recommended by the manufacturer.

OPERATING PRACTICES/HANDLING THE LOAD

1. Size of load.
 - A. No crane shall be loaded beyond the rated load except for test purposes.
 - B. The load to be lifted is to be within the rated load of the crane and its existing configuration.
 - C. When loads that are not accurately known are to be lifted, the person responsible for the job shall ascertain that the weight of the load does not exceed the crane rated load at the radius at which the load is to be lifted.
2. Attaching the load.
 - A. The load shall be attached to the hook by means of slings or other devices of sufficient capacity.
 - B. Hoist rope shall not be wrapped around the load.
3. Moving the load.

The operator shall determine that:

 - A. The crane is level and, where necessary, the vehicle/carrier is blocked properly.
 - B. The load is well secured and balanced in the sling or lifting device before it is lifted more than a few inches.

QUALIFICATIONS FOR AND CONDUCT OF OPERATORS AND OPERATING PRACTICES

N. No person should be permitted to stand or pass under a suspended load.

4. Stowing procedure.

Follow the manufacturer's procedure and sequence when stowing and un-stowing the crane.

3. Caution shall be exercised when working near overhead lines, because they can move horizontally or vertically due to wind, moving the danger zone to new positions.

4. In transit with no load and boom lowered the clearance shall be specified in Table 1.

5. A qualified signalperson shall be assigned to observe the clearance and give warning before approaching the above limits.

MISCELLANEOUS

OPERATING NEAR ELECTRICAL POWER LINES

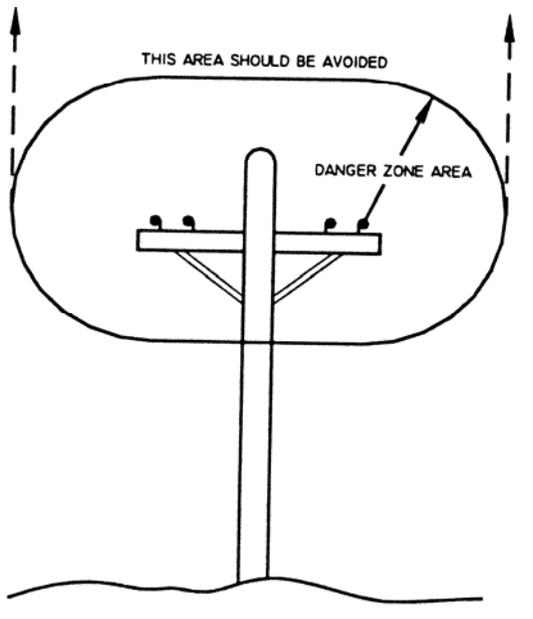

1. Cranes shall be operated so that no part of the crane or load enters into the danger zone shown above.

EXCEPTIONS

A. The danger zone may be entered after confirmation by an appointed person that the electrical distribution and transmission lines have been de-energized and visibly grounded at the point of work; or

B. The danger zone may be entered if insulating barriers (not a part of nor an attachment to the crane) have been erected to prevent physical contact with the lines.

2. For lines rated 50 kV or below, minimum clearance between the lines and any part of the crane or load (including handling appendages) shall be 10-ft. (3m). For higher voltages, see Table 1.

A. Any overhead wire shall be considered to be an energized line unless and until the person owning such line or the electrical utility authorities verify that it is not an energized line.

B. Exceptions to this procedure are allowed, if approved by the administrative or regulatory authority provided the alternate procedure insures equivalent protection and is set forth in writing.

C. Durable signs shall be installed at the operator's station and on the outside of the crane, warning that electrocution or serious bodily injury may occur unless a minimum clearance of 10 ft. (3.0m) between the crane or the load being handled and energized power lines. Greater clearances are required because of higher voltage as stated above. These signs shall be revised but not removed when local jurisdiction requires greater clearances.

TABLE 1

normal voltage, kV (phase to phase)		minimum required clearance	
		ft	(m)
<u>when operating near high voltage power lines</u>			
over	to 50	10	(3.50)
over	50 to 200	15	(4.6)
over	200 to 350	20	(6.1)
over	350 to 500	25	(7.62)
over	500 to 750	35	(10.67)
over	750 to 1000	45	(13.72)
<u>while in transit with no load and boom lowered</u>			
over	to 0.75	4	(1.22)
over	0.75 to 50	6	(1.83)
over	50 to 345	10	(3.83)
over	345 to 750	16	(4.87)
over	750 to 1000	20	(6.1)

--- IMPORTANT --- OPERATION OF UNIT

1. Make sure this manual has been thoroughly read by all crane operating personnel and supervisors.
2. A routine inspection of the crane should be mandatory before each operating day. Any defects should be corrected immediately.
3. At a job site the vehicle should be positioned so that the crane can adequately reach the load within the rated capacity (centerline of rotation to hoist hook).
4. Keep the vehicle as level as possible during operation.
5. For electric cranes, **engage emergency brake** and leave ignition on with transmission in neutral (or in park for automatic transmissions). Activate any crane power switches. For Auto Crane units requiring battery and hydraulic operation, **engage emergency brake**, place gear selector in neutral, press clutch, activate PTO, release clutch and after hydraulic fluid is warm, set throttle control to proper engine speed.
6. Always use outriggers from the truck to the ground. Be sure these are firm and adequately positioned. When rotating, **keep load as low to the ground as possible**.
7. Remove the transmitter from cab or storage area. Power transmitter on. Detach hook from dead man. Crane is now ready for operation.
8. Always boom up before rotating so the boom will clear the required boom support.
9. When extending the boom, always maintain clearance between the boom crown and the traveling block or hoist hook.
10. Always observe safe and practical operation to avoid possible accidents. Refer to Safety Tips and Precautions.
11. After completing lifting operations, return the boom to stowed position on the boom support. Avoid unneeded pressure on the boom support.
12. Store transmitter in proper location (in cab or storage area).
13. Return outriggers to stowed position. Make sure they are pinned in place or jacklegs are returned to compartment.
14. Check work area for any tools or equipment not stored.
15. Release throttle control, depress clutch and disengage PTO. Deactivate any crane power switches.
16. Report any unusual occurrence during crane operation that may indicate required maintenance or repair.
17. **NEVER** use two cranes to support a load too large for either crane.

OPERATION OF OUTRIGGERS

HYDRAULIC OUTRIGGERS

1. Shift crane/outrigger control valve to "outrigger" position.
2. Operate the outrigger control valves to position the outriggers.
3. After outriggers are positioned, return crane/outrigger selector to "crane" position.
4. Crane is now ready to operate.

MANUAL OUTRIGGERS

1. Pull lock pins to release jackleg or drop down outrigger and move to outermost lock position.
2. Make sure lock pins are reinstalled properly.
3. Lower outrigger pad to firm ground and adjust foot to take out slack.
4. Crane is now ready to operate.

INSPECTION REQUIREMENTS

REFERENCE ASME B30.5a AND OSHA 1910.180 FOR COMPLETE INSPECTION REQUIREMENTS

INSPECTION CLASSIFICATION

1. Initial inspection.

Prior to initial use, all new, altered, modified or extensively repaired cranes shall be inspected by a designated person to insure compliance with provisions of this standard.

2. Regular inspection.

Inspection procedure for cranes in regular service is divided into two general classifications based upon the intervals at which inspection should be performed. The intervals in turn are dependent upon the nature of the components of the crane and the degree of their exposure to wear, deterioration, or malfunction. The two general classifications are herein designated as "frequent" and "periodic" with respective intervals between inspections as defined below.

- A. Frequent inspection - daily or before each use
- B. Periodic inspection - one to twelve-month intervals or as specifically recommended by the manufacturer or qualified person.

**DESIGNATED PERSONNEL SHALL
PERFORM INSPECTIONS ONLY.**

FREQUENT INSPECTION

Inspections should also occur during operation for any deficiencies that might appear between regular inspections. Any deficiencies, such as those listed below, shall be carefully examined and a determination made as to whether they constitute a hazard:

1. Inspect control mechanisms for maladjustment that interferes with proper operation.
2. Inspect control mechanisms for excessive wear of components and contamination by lubricants or other foreign matter.

3. Inspect safety devices for malfunction.
4. Visually inspect all hydraulic hoses, particularly those that flex in normal operation of crane functions.
5. Inspect hooks and latches for deformation, chemical damage, cracks, and wear. Refer to ANSI/ASME B30.10.
6. Inspect for proper rope reeving.
7. Inspect electrical wiring and components for malfunctioning, signs of excessive deterioration, dirt and moisture accumulation.
8. Inspect hydraulic system for proper oil level and leaks.
9. Inspect tires for recommended inflation pressure, cuts and loose wheel nuts.
10. Inspect connecting pins and locking device for wear damage and loose retaining bolts.
11. Inspect rope for gross damage, such as listed below, which may be an immediate hazard.
 - A. Distortion such as kinking, crushing, unstranding, birdcaging, main strand displacement, or core protrusion. Loss of rope diameter in a short length or unevenness of outer strands should be replaced.
 - B. General corrosion.
 - C. Broken or cut strands.
 - D. Use care when inspecting sections of rapid deterioration around flange points, crossover points, and repetitive pickup points on drums.
 - E. Inspect number, distribution, and type of visible broken wires. Reference Rope Maintenance section in the owner's manual.

Continued use of rope depends upon good judgment by a designated person in evaluating remaining strength in a used rope after allowance for deterioration disclosed by inspection. Continued rope operation depends upon this remaining strength.

INSPECTION REQUIREMENTS

PERIODIC INSPECTION

Any deficiencies, such as those listed below, shall be carefully examined and determination made as to whether they constitute a hazard:

1. Inspect for deformed, cracked or corroded members in the crane structure and entire boom.
2. Inspect for loose bolts, particularly mounting bolts.
3. Inspect for cracked or worn sheaves and drums.
4. Inspect for worn, cracked, or distorted parts such as pins, bearings, shafts, gears, rollers and devices.
5. Inspect for excessive wear on brake and clutch system parts and lining.
6. Inspect crane hooks for cracks.
7. Inspect travel steering, braking, and locking devices for malfunction.
8. Inspect for excessively worn or damaged tires.
9. Inspect hydraulic hose, fittings, and tubing for the following problems:
 - A. Evidence of leakage at the surface of the flexible hose or its junction with metal and coupling.
 - B. Blistering, or abnormal deformation to the outer covering of the hydraulic or pneumatic hose.
 - C. Leakage at threaded or clamped joints that cannot be eliminated by normal tightening or recommended procedures.
 - D. Evidence of excessive abrasion or scrubbing on the outer surface of a hose, rigid tube, or fitting. Means shall be taken to eliminate the interference of elements in contact or otherwise protect the components.
10. Inspect hydraulic pumps and motors for the following problems:
 - A. Loose bolts and fasteners.
 - B. Leaks at joints between sections.
 - C. Shaft seal leaks.
 - D. Unusual noises or vibrations.
 - E. Loss of operating speed.
 - F. Excessive heating of the fluid.
 - G. Loss of pressure.
11. Inspect hydraulic valves for the following problems:
 - A. Cracks in valve housing.
 - B. Improper return of spool to neutral position.
 - C. Leaks at spools or joints.
 - D. Sticking spools.
 - E. Failure of relief valves to attain or maintain correct pressure setting.
 - F. Relief valve pressure shall be checked as specified by the manufacturers.
12. Inspect hydraulic cylinders for the following problems:
 - A. Drifting caused by fluid leaking across piston.
 - B. Rod seals leaking.
 - C. Leaks at welding joints.
 - D. Scored, nicked, or dented cylinder rods.
 - E. Damaged case (barrel).
 - F. Loose or deformed rod eyes or connecting joints.
13. Inspect hydraulic filters for evidence of rubber particles on the filter elements indicating possible hose, "O" ring, or other rubber component deterioration. Metal chips or pieces on the filter may denote failure in pumps, motors, or cylinders. Further inspection will be necessary to determine the origin of the problem before corrective action can be taken.
14. Inspect labels to confirm correct location and legibility. Reference decal layout in this manual for proper location of decals.
15. **Rope Inspections need not be at equal calendar intervals and should be more frequent as the rope approaches the end of useful life.** A qualified person shall inspect the wire rope based on such factors as:
 - A. Expected rope life as determined by experience on the particular installation or similar installations.
 - B. Severity of environment.
 - C. Percentage of capacity lifts.
 - D. Frequency rates of operation.
 - E. Exposure to shock loads.

This inspection shall cover the entire length of the rope. Only the surface wires need to be inspected and no attempt should be made to open the rope. Any deterioration resulting in appreciable loss of original strength shall be noted and determination made as to whether use of the rope would constitute a hazard. A few notable deterioration points are listed below:

INSPECTION REQUIREMENTS

- A. Reduction of rope diameter below nominal diameter due to loss of core support.
- B. Internal or external corrosion.
- C. Wear of outside wires.
- D. Severely corroded, cracked, bent, worn, or improperly applied connections.

CRANES NOT IN REGULAR USE

A crane, which has been idle for a period of over one month or more, shall be given an inspection conforming to the "initial" and "regular" inspection requirements of this section.

INSPECTION RECORDS

Dated records of periodic inspection should be made on critical items such as brakes, crane hooks, rope, cylinders, and relief pressure valves.

TESTING REQUIREMENTS

REFERENCE ASME B30.5a AND OSHA 1910.180 FOR COMPLETE TESTING REQUIREMENTS

TESTING SHALL BE PERFORMED BY DESIGNATED PERSONNEL ONLY.

Prior to initial use, all new, altered, modified, or extensively repaired cranes shall be tested for compliance with the operational requirements of this crane.

Test requirements:

1. Test all functions to verify speed and operation.
2. Check that all safety devices are working properly.
3. Confirm operating controls comply with appropriate function labels.
4. Test loads shall not exceed 110% of the manufacturer's load rating.
5. Written reports shall be maintained showing test procedures and confirming the adequacy of repairs.

GENERAL REPAIRS AND MAINTENANCE

REFERENCE ASME B30.5a AND OSHA 1910.180 FOR COMPLETE MAINTENANCE AND REPAIR REQUIREMENTS

A preventative maintenance program should be established based on this section and all replacement parts should be obtained from AutoCrane Company.

For replacement parts contact your local authorized distributor.

MAINTENANCE PRECAUTIONS

1. Place crane where it will cause the least interference with other equipment or operations.
2. Verify all controls are in the "off" position and all operating features secured from inadvertent motion by brakes, pawls, or other means.
3. The means for starting the crane shall be rendered inoperative.
4. The boom should be secured in place before maintenance.
5. Relieve hydraulic oil pressure from all hydraulic circuits before loosening or removing hydraulic components.
6. Warning or "OUT OF ORDER" signs shall be placed on all crane controls.
7. After adjustments and repairs have been made, the crane shall not be returned to service until all guards have been reinstalled, trapped air removed from hydraulic system (if required), safety devices reactivated, and maintenance equipment removed.

ADJUSTMENTS AND REPAIRS

1. Any hazardous conditions disclosed by the inspection requirements shall be corrected before operation of crane is resumed. Only designated personnel shall do adjustments and repairs.
2. Adjustments shall be maintained to assure correct functioning of components, the following are examples:
 - A. Functional operating mechanism.
 - B. Safety devices.
 - C. Control systems.
3. Repairs or replacements shall be provided as needed for operation, the following are examples:
 - A. Critical parts of functional operating mechanisms which are cracked, broken, corroded, bent, or excessively worn.

- B. Critical parts of the crane structure which are cracked, bent, broken, or excessively corroded.
 - C. Crane hooks showing cracks, damage, or corrosion shall be taken out of service. Repairs by welding are not recommended.
4. If bleeding the hydraulic system is required, run each crane function until smooth operation of that particular function is noticeable.

LUBRICATION

All moving parts of the crane, for which lubrication is specified, should be regularly lubricated per the manufacturer's recommendations and procedures. **Reference Lubrication and Maintenance Schedule in this manual.**

ROPE REPLACEMENT

No precise rules can be given for determination of the exact time for replacement of rope, since many variable factors are involved.

1. Conditions such as the following shall be reason for questioning continued use of the rope or increasing the frequency of inspection:
 - A. In running ropes, six randomly distributed broken wires in one lay or three broken wires in one strand in one lay.
 - B. One outer wire broken at the contact point with the core of the rope structure and protrudes or loops out of the rope structure. Additional inspection of this section is required.
 - C. Wear of one third of the original diameter of the outside individual wire.
 - D. Kinking, crushing, bird caging, or any other damage resulting in distortion of the rope structure.
 - E. Evidence of any heat damage from any cause.
 - F. Reduction from nominal diameter of more than 1/64 in. (0.4mm) for diameters up to and including 5/16 in. (8 mm), 1/32 in. (0.8 mm) for diameter 3/8 in. (9.5 mm) to and including 1/2 in. (13 mm), 3/64 in. (1.2 mm) for diameter 9/16 in. (14.5 mm) to and including 3/4 in. (19 mm), 1/16 in. (1.6 mm) for diameter 7/8 in. (22 mm) to and including 1 1/8 in. (29 mm), 3/32 in.

GENERAL REPAIRS AND MAINTENANCE

(2.4 mm) for diameters 1 1/4 in. (32 mm) to and including 1 1/2 in. (38 mm).

- G. In standing ropes, more than two broken wires in one lay in sections beyond end connections or more than one broken wire at an end connection.
- 2. Replacement rope shall have a strength rating at least as great as the original rope furnished or recommended by AutoCrane. A rope manufacturer, AutoCrane, or a qualified person shall specify any deviation from the original size, grade, or construction.

ROPE MAINTENANCE

- 1. Rope should be stored to prevent damage or deterioration.
- 2. Unreeling or uncoiling of rope shall be done as recommended by the rope manufacturer and with care to avoid kinking or inducing twist.
- 3. Before cutting a rope, seizing shall be placed on each side of the place where the rope is to be cut to prevent unlaying of the strands. On pre-formed rope, one seizing on each side of the cut is required. On non-preformed ropes of 7/8 in. (22 mm) diameter or smaller, two seizings on each side of the cut are required, and for non-preformed rope 1 in. (25 mm) diameter or larger, three seizings on each side of the cut are required.
- 4. During installation care should be exercised to avoid dragging of the rope in the dirt or around objects that will scrape, nick crush or induce sharp bends in it.
- 5. Rope should be maintained in a well-lubricated condition. It is important that lubricant applied as a part of a maintenance program shall be compatible with the original lubricant and to this end the rope manufacturer should be consulted. Lubricant applied shall be the type that does not hinder visual inspection. Those sections of rope that are located over sheaves or otherwise hidden during inspection and maintenance procedures require special attention when lubricating rope. The object of rope lubrication is to reduce internal friction and to prevent corrosion.
- 6. When an operating rope shows greater wear or well-defined localized areas than on the remainder of the rope, rope life can be extended in some cases by shifting the wear to different areas of the rope.

MAINTENANCE OF BATTERIES

Maintenance of Auto Crane unit batteries differs very little from the generally prescribed maintenance of any lead acid battery. All batteries must be kept properly charged, properly filled with water, and relatively clean.

Keep Properly Charged

Many things affect the proper charge to a battery, such as:

1. Regulator settings.
2. Proper tightness of belts on the alternator or generator.
3. Good, clean connections of all cables and wires at the following places:
 - a. Battery.
 - b. Regulator.
 - c. Starting motor.
 - d. Alternator or generator.
 - e. Ground connections (most important).

It is of extreme importance to keep the battery as fully charged as possible without overcharging, especially when vehicles are left outside for extended periods in extremely cold climates. A battery can freeze. Freezing points for various specific gravities of acid are as follows:

Specific Gravity (Corrected to 80°F)	Freezing Temp. Degrees F.
1.280	-90°F
1.250	-62°F
1.200	-16°F
1.150	5°F
1.100	19°F

As shown, a half-charged battery (about 1.100 specific gravity) cannot stand for any length of time at 20°F or it will freeze.

The main reason for keeping the battery as fully charged as possible without over-charging is to insure that power is available even though the vehicle has been standing for some time.

Keep Properly Filled with Water

The battery should *always* be properly filled with water. If the electrolyte level is allowed to fall below the top of the plates, the results become threefold:

1. The exposed portion of the plate will become sulfated.
2. The portion of the plate exposed is not usable.
3. That portion of the acid remaining becomes more concentrated and may cause more rapid

deterioration of the remaining parts of the battery.

Keep A Relatively Clean Battery

The battery should be kept clean. Batteries filled with acid and which are not in use self-discharge to a limited degree because of the nature of the materials within the battery. If dirt is allowed to collect on the top of the battery (and this dirt absorbs moisture) and electrical path can be set up between the various terminals of the battery and the ground. Once such a path has been established, the self-discharge of the battery is accelerated. This also accelerates corrosion of the battery cables at the terminals.

Periodic Maintenance is Needed

A definite program of periodic maintenance of all batteries should be conducted on a regular basis. Periodic maintenance includes:

1. Checking belts for tightness on the charging equipment.
2. Checking battery electrolyte levels.
3. Checking cables for good connections.
4. Cleaning where corrosion is apparent.

When corrosion is cleaned off, the cable terminals and battery terminals should be coated with a light coating of petroleum jelly before they are replaced. When terminals are cleaned, the top of the battery should be cleaned with a mild solution of soda water.

Low Maintenance Batteries (Maintenance Free)

Low maintenance batteries should not be used on AutoCrane Cranes or trucks equipped with AutoCrane Cranes. The batteries are not designed for "deep" discharge.

Testing Your Battery

If the condition of the battery is in question, it should be removed from the vehicle, taken to the shop, and allowed to reach room temperature. It should then be recharged until specific gravity readings taken at one-half hour intervals. If the specific gravity readings are fairly uniform, the battery should be checked with a high rate tester. Use the tester in accordance with the manufacturer's instructions. The high rate tester is the best method to test a questionable battery.

MAINTENANCE OF BATTERIES

If, after charging, it is noted that the specific gravity reading of one cell is 30 points less than any of the other cells, it may be assumed that the cell is bad and that the battery should be replaced. If all cells are uniform but not up to full charge, a low rate of charge should be attempted for an extended time. This usually will recover a badly sulfated battery.

Replacing a Battery

If it is necessary to replace a battery, and a dry charge battery is used, the following procedure applies:

1. Fill the battery with electrolyte of the proper specific gravity.

2. Place the battery on charge according to the manufacturer's instructions.

It is essential that the second step above be followed to ensure that the battery going on the vehicle is fully charged.

It is also very important that the battery hold-downs be checked periodically to insure that the batteries are properly positioned to avoid vibration problems, breakage of cables or terminals. Care must be taken to avoid cracking or breaking containers or covers by tightening hold-down fixtures excessively. They also must not be so loose that breakage results from a hold-down that is too loose.

14005H

LUBRICATION & MAINTENANCE SCHEDULE

SERVICE PERFORMED	DAY	WKLY	3 MOS	6 MOS	YEAR	NOTES
LOAD HOOK	X					INSPECT HOOK & LATCH FOR DEFORMATION, CRACKS, & CORROSION
CABLE DRUM	X					MAKE SURE CABLE IS WOUND EVENLY ON DRUM
HOIST / BOOM CABLE	X					CHECK FOR FLATTENING, KINKS, & BROKEN STRANDS, SEE MANUAL
HYD. HOSES	X					VISUAL INSPECTION
HYD. FLUID	X					CHECK FLUID LEVEL
PIN RETAINING BOLTS	X					CHECK TORQUE TO 23 FT-LBS (GRADE 5), 35 FT-LBS (GRADE 8) AS REQUIRED
MOUNTING BOLTS		X				CHECK TORQUE TO 501 FT-LBS AS REQUIRED
ROTATION RING GEAR		X				LUBE WITH MOBILETAC LL, OR LUBRIPLATE P/N 15263, OR EQUAL
SHEAVE BEARINGS		X				SEALED BEARING, REPLACE IF ROUGH OR LOOSE
ALL OTHER BOLTS		X				CHECK TIGHTEN AS REQUIRED
LIFT CYLINDER BEARINGS			X			GREASE WITH MOBILEPLEX EP-2 OR EQUIVALENT @ ZERKS
ROTATION BEARING			X			GREASE WITH MOBILEPLEX EP-2 OR EQUIVALENT @ ZERKS
ROTATION BEARING BOLTS			X			CHECK TORQUE TO 200 FT-LBS (HEX HEAD) 250 FT-LBS (SOCKET HEAD) AS REQUIRED
ROTATION GEAR BOX			X			CHECK TORQUE TO 80 FT-LBS AS REQUIRED
ROTATION GEAR BOX				X		EP GEAR LUBE SAE 80-90
HYDRAULIC FLUID					X	DRAIN, FLUSH, AND REFILL WITH MOBILE DTE 13 HYD. OIL
BOOM SLIDE PADS	PADS GREASED WHEN REPLACED					
FOR ADDITIONAL INFORMATION SEE:	1) OWNER'S MANUAL 2) OSHA SECTION 1910.180 3) ANSI B30.5-1989					

CAUTION: Routine maintenance insures trouble-free operation and protects your investment. All warranties are void if maintenance is neglected.

14005H

LUBRICATION & MAINTENANCE SCHEDULE

NOTES:

1. Use only authorized parts. Any damage or malfunction caused by the use of unauthorized parts is not covered by Warranty or Product Liability.
2. Once a bolt has been torqued to its rated capacity and then removed; the bolt should be replaced with a new one.
3. Auto Crane Company recommends that this crane be serviced per "Crane Inspection Log" P/N 999978. These logs should be filled in at the intervals noted and kept as a permanent record. Additional copies are available from your local distributor.

14005H

SAFETY DECAL SECTION

PART NO.: 040579000
 DECAL: OPERATING INSTRUCTIONS
 FUNCTION: To inform the operator of the proper procedure to follow for safe operation of the crane.
 USED ON: All Cranes.
 QUANTITY: 1
 PLACEMENT: Right side plate.

⚠ CAUTION

1. INSPECT VEHICLE AND CRANE INCLUDING OPERATION, PRIOR TO USE DAILY.
2. DO NOT USE THIS EQUIPMENT EXCEPT ON SOLID, LEVEL SURFACE WITH OUTRIGGERS PROPERLY EXTENDED AND CRANE MOUNTED ON FACTORY-RECOMMENDED TRUCK.
3. BEFORE OPERATING THE CRANE, REFER TO MAXIMUM LOAD (CAPACITY) CHART ON CRANE FOR OPERATING (LOAD) LIMITATIONS.
4. OPERATE ALL CONTROLS SLOWLY AND SMOOTHLY.
5. KEEP LOAD UNDER BOOM TIP. DO NOT SIDE LOAD BOOM OR DRAG LOADS. AVOID FREE SWINGING LOADS.
6. DO NOT OPERATE, WALK OR STAND BENEATH BOOM OR A SUSPENDED LOAD.
7. KEEP AT LEAST 5 WRAPS OF LOADLINE ON HOIST DRUM.
8. FOR TRAVELING, BOOM AND OUTRIGGERS MUST BE IN THE STOWED POSITION.
9. ALL REMOVABLE PENDANTS MUST BE STORED IN CAB OR TOOL COMPARTMENT WHEN CRANE IS NOT IN USE.

P/N 040579

PART NO.: 040580000
 DECAL: OPERATING TRAINING
 FUNCTION: To inform the operator of the need to receive proper training before using the crane.
 USED ON: All Cranes.
 QUANTITY: 1
 PLACEMENT: Right side plate.

⚠ DANGER

AN UNTRAINED OPERATOR
SUBJECTS HIMSELF AND
OTHERS TO

DEATH OR SERIOUS INJURY

- 1.) YOU MUST HAVE BEEN TRAINED IN THE OPERATION OF THIS CRANE, AND
- 2.) YOU MUST KNOW AND FOLLOW THE SAFETY AND OPERATING RECOMMENDATIONS CONTAINED IN THE MANUFACTURER'S MANUAL, YOUR EMPLOYER'S WORK RULES AND APPLICABLE GOVERNMENT REGULATIONS.

P/N 040580

PART NO.: 040632000
 DECAL: TAMPERING WITH OVERLOAD DEVICE
 FUNCTION: To inform the operator that tampering with the overload device may cause a unit failure or possible personal injury.
 USED ON: All Cranes equipped with a load sensor.
 QUANTITY: 1
 PLACEMENT: Right side of valve sensor.

⚠ WARNING

TAMPERING WITH OVERLOAD DEVICE VOIDS WARRANTY. OVERLOADED CRANE MAY HYDRAULICALLY RELEASE AND LET LOAD DOWN TO GROUND. OVERLOAD PROTECTION DEVICE CANNOT FUNCTION WITH BOOM BELOW HORIZONTAL (0°). HOIST UP, BOOM DOWN, AND EXTEND OUT WILL BE INOPERATIVE WHEN CRANE IS IN OVERLOAD CONDITION.

P/N 040632

14005H SAFETY DECAL SECTION

PART NO.: 040529000
 DECAL: ELECTROCUTION HAZARD
 FUNCTION: To inform the operator of the hazard involved with contacting electrical power lines with crane boom.
 USED ON: All Cranes.
 QUANTITY: 2
 PLACEMENT: Both sides of end of lower boom.

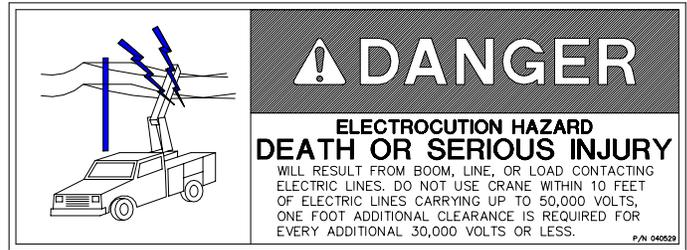

PART NO.: 040517000
 DECAL: STAY CLEAR OF BOOM
 FUNCTION: To inform the operator of the hazard of proximity or contact with the crane boom during operation.
 USED ON: All Cranes.
 QUANTITY: 2
 PLACEMENT: Both sides of crown.

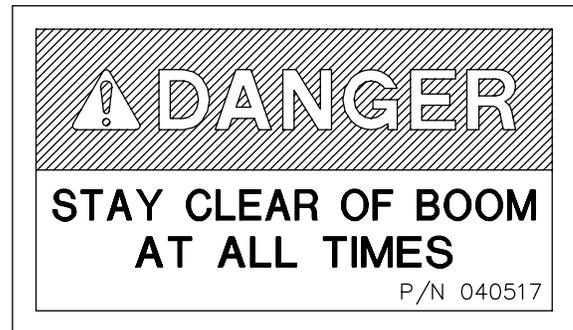

PART NO.: 040518000
 DECAL: STAY CLEAR OF LOAD
 FUNCTION: To inform the operator of the hazard of proximity or contact with the crane load during operation.
 USED ON: All Cranes.
 QUANTITY: 2
 PLACEMENT: Both sides of traveling block.



14005H

SAFETY DECAL SECTION

PART NO.: 040587000

USED ON: All cranes equipped with a load sensor.

DECAL: LOAD SENSOR, DON'T TAMPER

QUANTITY: 2

FUNCTION: To inform the operator that the load sensor is pre-set and that tampering with the sensor may cause potentially hazardous situation.

PLACEMENT: Both sides of the lift cylinder near the load sensor.

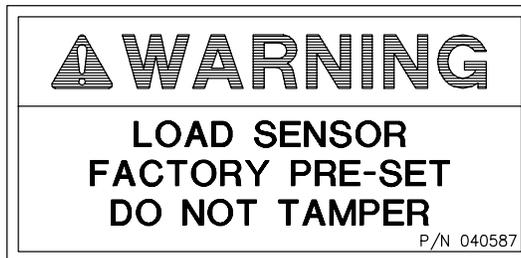

PART NO.: 040519000

USED ON: All cranes.

DECAL: SCISSORS POINT

QUANTITY: 2

FUNCTION: To inform the operator of possible danger at scissors point on crane.

PLACEMENT: Both sides of the lift cylinder.

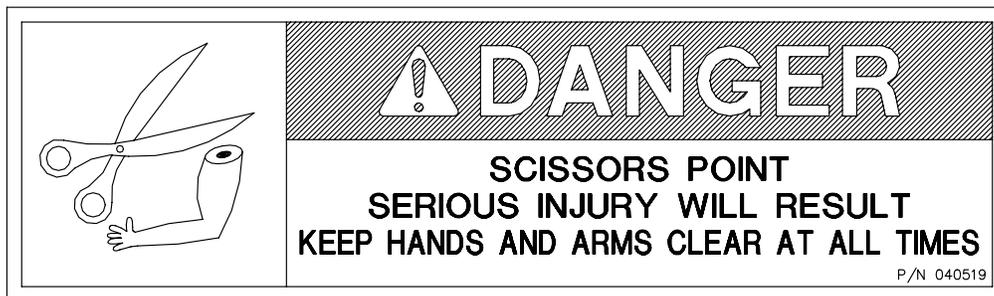

NOTES

14005H

SAFETY DECAL SECTION

PART NO.: 460169000 USED ON: All Cranes equipped with FM controls.

DECAL: REMOTE CONTROL QUANTITY: 1

FUNCTION: To inform the operator of failure to follow the safety precautions may result in equipment failure or serious personal injury. PLACEMENT: FRONT OF POWER UNIT



WARNING

REMOTE CONTROL SAFETY PRECAUTIONS

READ THE OPERATOR'S MANUAL before using the Remote Control System. Failure to follow the safety precautions may result in equipment failure or serious personal injury.

MAKE SURE MACHINERY AND SURROUNDING AREA IS CLEAR BEFORE OPERATING REMOTE CONTROL SYSTEM. Do not activate the Remote Control System unless it is safe to do so.

TURN OFF THE RECEIVER POWER BEFORE WORKING ON THE MACHINE. Always disconnect the Remote Control System before doing any maintenance to prevent accidental operation of the machine.

DO NOT MODIFY EQUIPMENT WITHOUT WRITTEN APPROVAL FROM THE MANUFACTURER.

CARE

KEEP DRY. Do not clean the Transmitter / Receiver under high pressure. If water or other liquids get inside the Transmitter battery or Receiver compartment, immediately dry the unit. Remove the case and let the unit air dry.

Clean the unit after operation using a damp cloth to remove any mud, dirt, concrete, etc. from the unit and prevent clogging of buttons, switches, etc.

MAINTENANCE / WELDING

DISCONNECT THE RECEIVER BEFORE WELDING ON THIS MACHINE. Failure to disconnect will result in the destruction of the Receiver.

460169000 A

14005H DECAL LAYOUT

P/N: 470040001

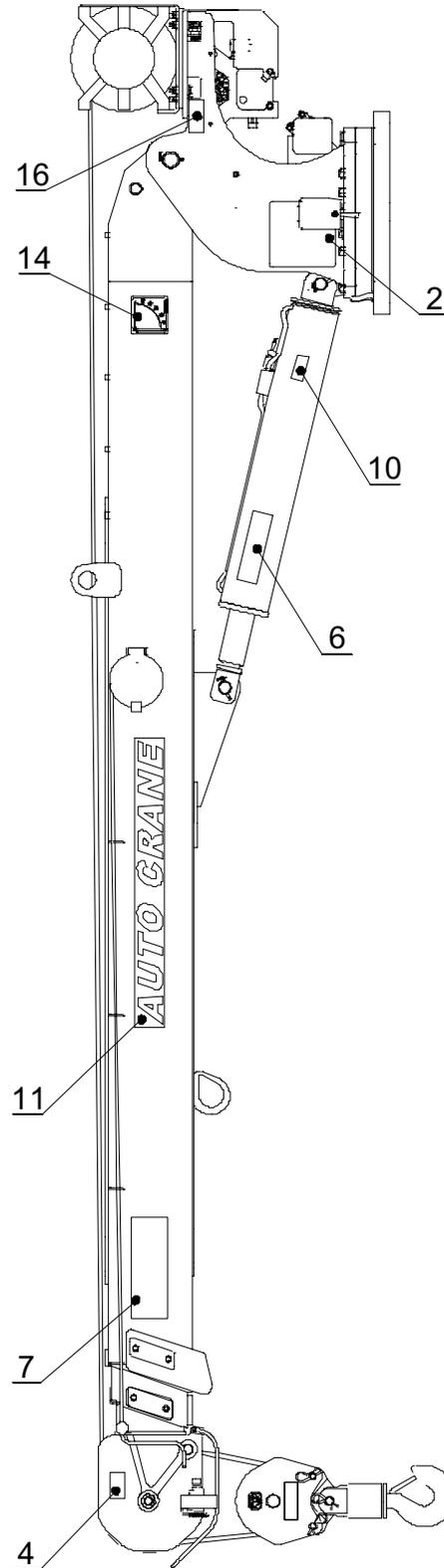
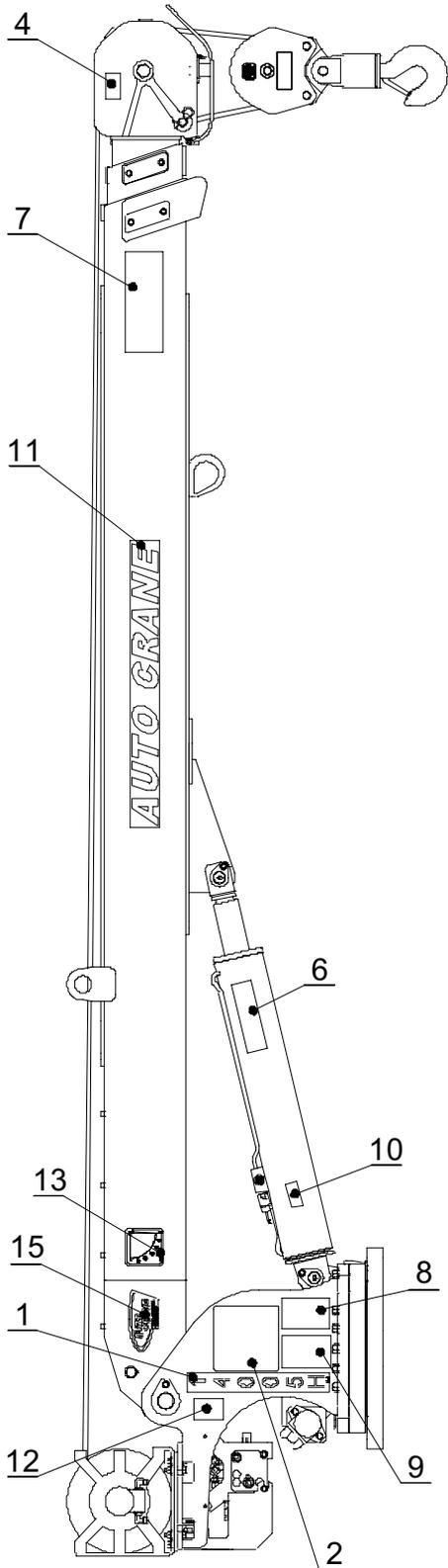

14005H DECAL LAYOUT

P/N: 470040001

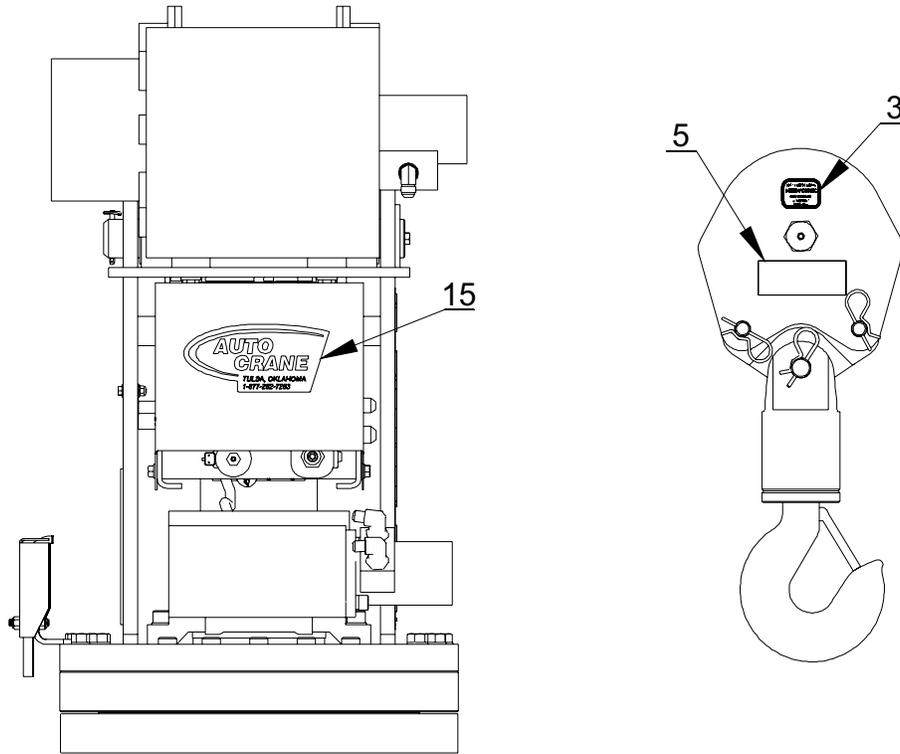

ITEM NO.	QTY.	PART NO.	DESCRIPTION
1	1	470041000	DECAL, 14005H
2	2	470042000	DECAL, LOAD CHART 14005HP
3	2	470044000	DECAL MAX BLOCK LOAD
4	2	040517000	DECAL STAY CLEAR OF BOOM
5	2	040518000	DECAL STAY CLEAR OF LOAD
6	2	040519000	DECAL DANGER SCISSOR POINT
7	2	040529000	DECAL DANGER "ELECTROCUTION HAZARD" POWER LINE
8	1	040579000	DECAL OPERATION INSTRUCTIONS
9	1	040580000	DECAL TRAINED OPERATOR
10	2	040587000	DECAL WARNING LOAD SENSOR
11	2	040624000	DECAL AUTO CRANE
12	1	040632000	DECAL WARNING - OVERLOAD
13	1	320318000	DECAL ANGLE INDICATOR CS
14	1	320318001	DECAL ANGLE INDICATOR SS
15	2	360034000	DECAL AUTO CRANE LOGO
16	1	330622000	DECAL SERIAL NO

NOTES

14005H GENERAL DIMENSIONS

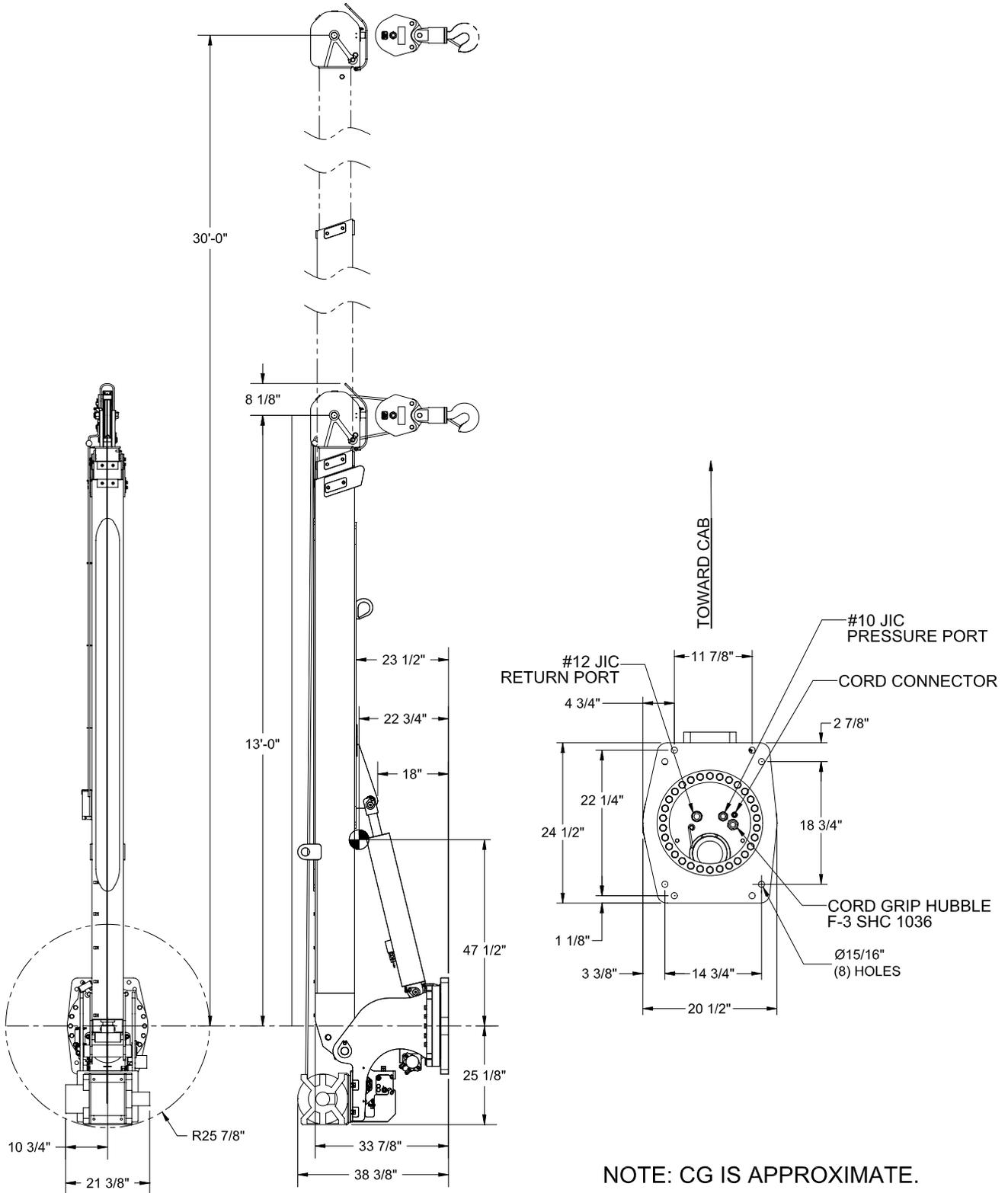

14005H

MOUNTING AND INSTALLATION

WARNING: NOT INTENDED FOR TRUCK MOUNTING. INSTALLATION INSTRUCTIONS APPLY TO RIG/TRAILER MOUNTING ONLY. TRUCK MOUNTING REQUIRES ADDITIONAL INSTRUCTIONS/PRECAUTIONS NOT COVERED IN THIS MANUAL.

1. Check to make sure the following items are with your crane. Please note the different, model specific, quantities.

ITEM	QTY	PART NO.	DESCRIPTION
1	1	480689000	FUSE 15 AMP TIME-DELAY
2	1	480688000	FUSE HOLDER IN-LINE WATERPROOF
3	120"	800596000	WIRE 16G 600V 1C YEL
4	6	634401000	TIE CABLE - MEDIUM
5	6	750738000	STICK-ON
6	5	320357000	TERMINAL NON-INS S/O W/L
7	1	320363000	PLUG TERMINAL CONNECTOR
8	1	340638000	CONDUCTOR POWER
9	1	320355000	POWER RELAY
10	8	018900000	NUT HX 7/8 - 14 UNF GR8
11	8	022200000	WASHER SP LK 7/8
12	8	015104000	7/8-14 UNF X 5 HH GR8
13	1	470098000	MANUAL 14005HP, SPECIAL
14	1	366520002	JUNCTION BOX ASSY
15	1	366466000	WIRE HARNESS, TRUCK FUNCTIONS
16	1	680040000	PENDANT ASSEMBLY

2. Pressure and return hoses are not furnished with this crane. The installer must provide the hoses and the lengths determined at installation.

REQUIREMENTS FOR INSTALLATION USING 23 GALLON RESERVOIR (*)

- A. **RETURN LINE** FROM CRANE TO RESERVOIR (IN COMPARTMENT): -12 SAE 100R2 (OR EQUIVALENT). INSTALLER DETERMINES HOSE LENGTH. RETURN LINES LONGER THAN 6 FEET SHOULD BE SIZE - 16. HOSE END FITTINGS ARE -12 JIC FEMALE SWIVEL (CRANE END) AND -12 JIC FEMALE SWIVEL (RESERVOIR END).
- B. **PRESSURE LINE** FROM PUMP TO CRANE: -10 SAE 100R12 (OR EQUIVALENT) WITH A **2,850-PSI MINIMUM WORKING PRESSURE**. INSTALLER DETERMINES HOSE LENGTHS. HOSE END FITTINGS ARE BOTH -10 JIC FEMALE SWIVEL.

(*) **NOTE:** 23 GAL RESERVOIR IS MINIMUM REQUIREMENT FOR CRANE ONLY. THE ADDITION OF OTHER AUXILLARY EQUIPMENT WILL REQUIRE ADDITIONAL CAPACITY.

CAUTION – FAILURE TO USE CLEAN HYDRAULIC HOSES AND COMPONENTS MAY CONTAMINATE THE CRANE AND HYDRAULIC SYSTEM AND VOID WARRANTY.

3. Crane must be provided with a flow of 12 gallons per minute and a pressure of 2,800 PSI. Excess flow will cause erratic operation, and too little flow will cause poor crane operation.
4. Make sure mounting surface is properly reinforced to withstand 78,000 ft-lb capacity loading of crane and that outriggers are used to provide total stability for the trailer/mount.
5. A 15 3/4"-dia. hole should be cut out of mounting location (centered with mounting bolts) for access to hydraulic connections.
6. Make sure the mounting bolts are 7/8" dia, grade 8. Torque bolts to 501 ft-lbs.
7. When crane is not in operation, a boom support should always be used. Traveling block should be connected to hook loop.
8. Electrical hookup:

14005H

MOUNTING AND INSTALLATION

Wiring (cable from junction box):

- A. CONNECT THE BLACK WIRE TO THE BATTERY NEGATIVE (GROUND).
- B. CONNECT THE RED WIRE TO FUSED 12VDC POWER. 12VDC POWER SHOULD BE SUPPLIED THROUGH A DEDICATED SWITCH THAT IS POWERED ONLY WHEN THE IGNITION SWITCH IS ON.

NOTE: ALL ELECTRICAL CONNECTIONS BETWEEN THE CRANE AND THE VEHICLE SHOULD BE MADE USING RELAYS TO ISOLATE THE ELECTRICAL SYSTEMS OF EACH AS MUCH AS POSSIBLE.

WARNING! FAILURE TO CORRECTLY PLUMB AND WIRE CRANE CAN CAUSE INADVERTENT OPERATION AND DAMAGE TO CRANE AND/OR PERSONNEL!

9. Once crane and plumbing are installed on the trailer/mount, fill the reservoir to top of sight glass (mobile DTE 13 or equal). Before operating crane, connect together the pressure and return hoses going to base of crane using 10-12 JIC union and engage PTO with engine running. Allow oil to circulate for 15 to 20 minutes. This will flush contaminants from the system back to the return line filter. Operate all cylinders to full extension and retraction a minimum of six times, to bleed air from system. Return all cylinders to the stored position and disengage PTO. Refill reservoir to top sight glass. To ensure 12 gallons per minute (GPM), install an in-line flow meter between the crane and the reservoir in the return hose.
10. Load test the crane to ensure proper functioning and trailer/mount stability.
11. Make certain the owner's manual is delivered to the customer.
12. For additional help: call the service department at the Auto Crane Company (918) 836-0463 (Tulsa, Oklahoma).

14005H GENERAL ASSEMBLY HARDWIRED - P/N: 470080002

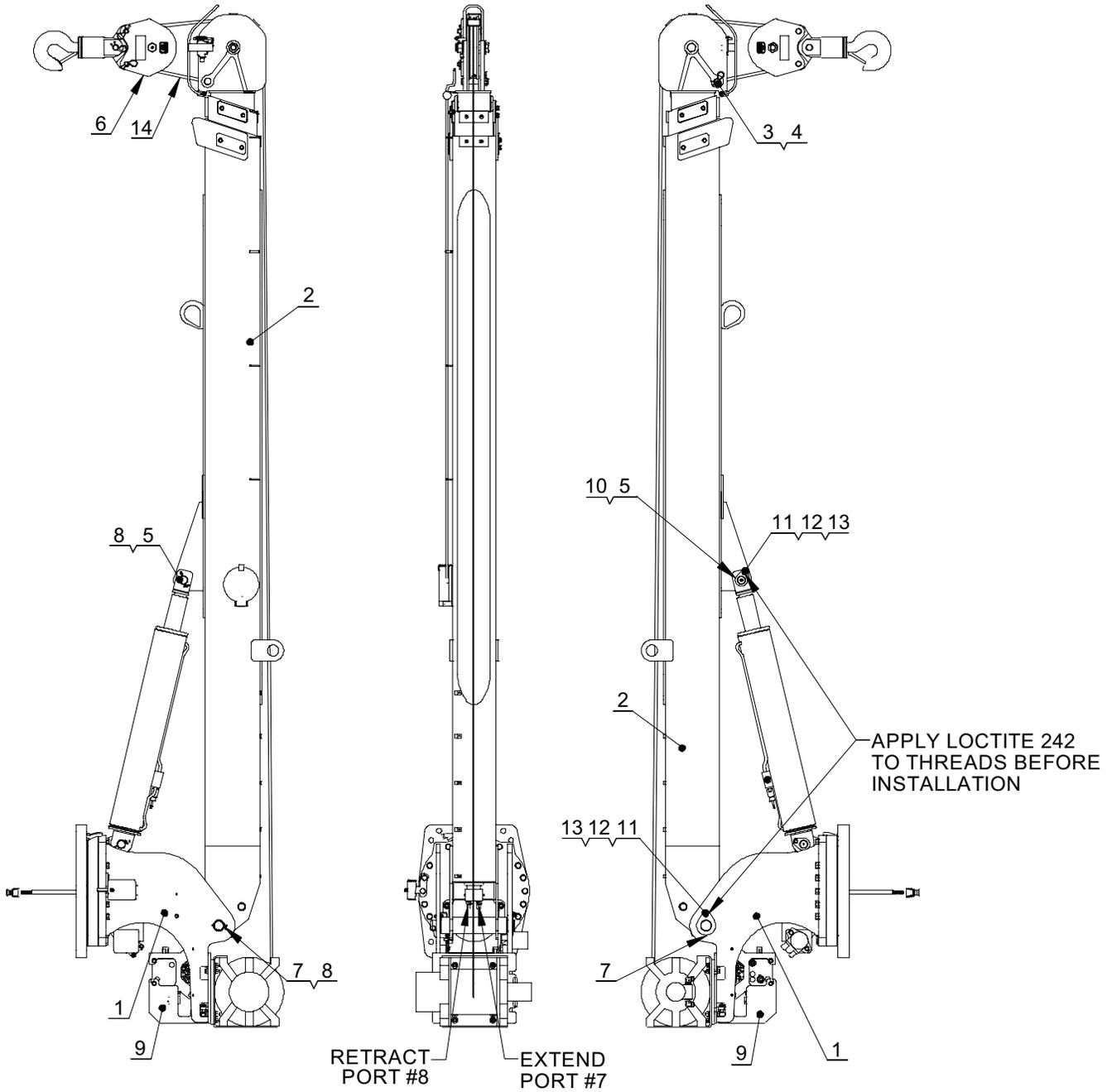

ELECTRICAL SCHEMATIC P/N: 470093000
HYDRAULIC SCHEMATIC P/N: 470094000

14005H GENERAL ASSEMBLY HARDWIRED - P/N: 470080002

ITEM NO.	QTY.	PART NO.	DESCRIPTION
1	1	470030002	PEDESTAL ASSY, 14005H, HW
2	1	470050000	14005H BOOM ASSEMBLY
3	1	470076000	PIN, 1 DIA 4-9/16 LG
4	1	360124000	PIN HITCH
5	1	470077000	PIN, CYLINDER 1.5 OD
6	1	470025000	TRAVELING BLOCK ASSEMBLY
7	1	470032000	PIN WLDMNT, BOOM PIVOT, 14005
8	2	360677000	PIN, 1/4 COTTERLESS RING
9	1	460073000	COVER, REAR
10	1	239300000	ZERK, GREASE
11	2	320976000	WASHER, FLAT, 3/8 SAE HARDENED
12	2	021100000	WASHER SP LK 3/8
13	2	008702000	SCREW HX HD 3/8-16UNC X 1 1/4 LG GR5
14	1	470017000	WIRE ROPE ASSY 1/2
15	1	470092000	SHIP KIT, 14005HP, HW, H&P SPECIAL
16	1	470040001	14005H, DECAL LAYOUT

14005H PEDESTAL ASSEMBLY HARDWIRED - P/N: 470030002

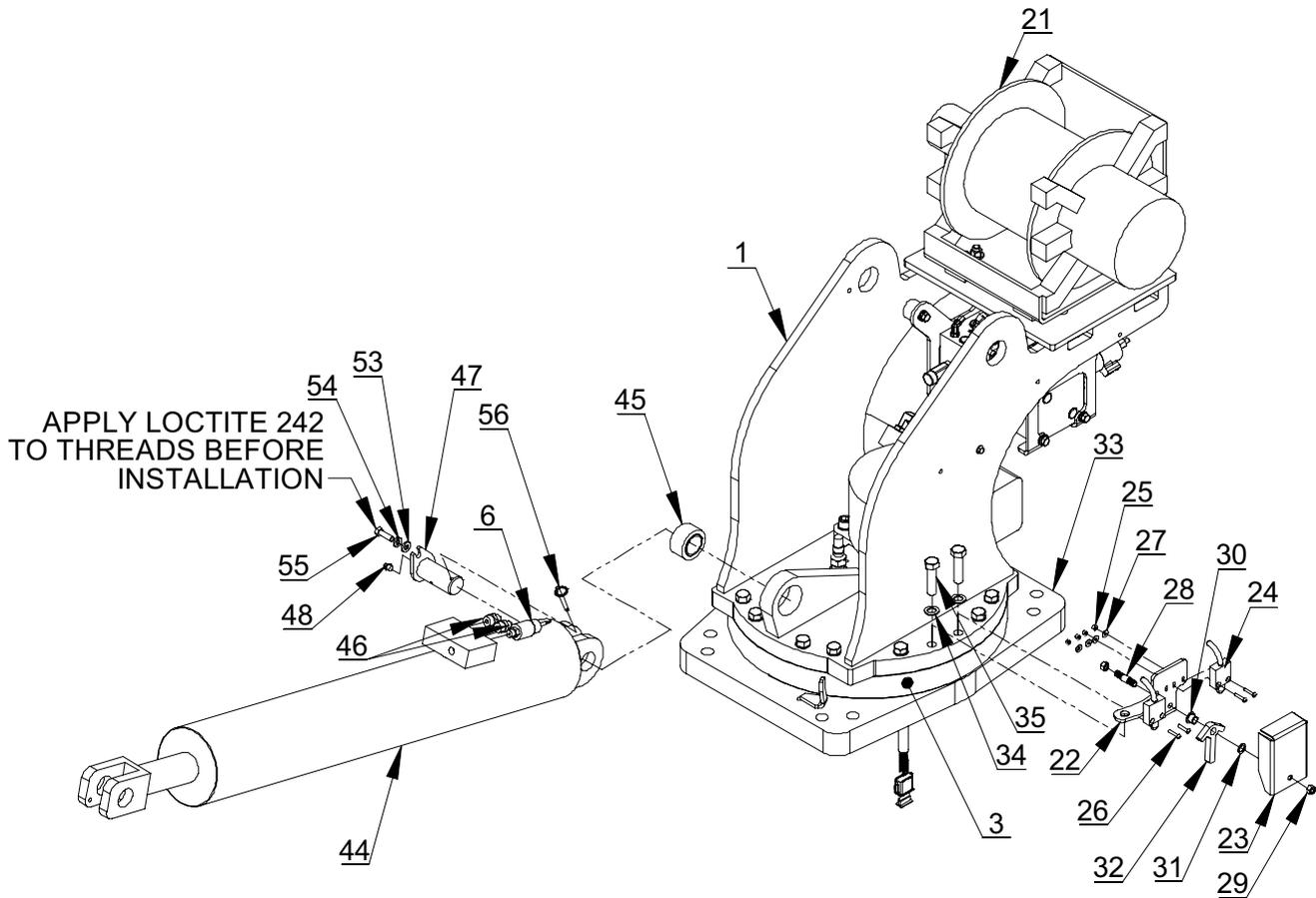

HYDRAULICS:

- PORT #1: HOIST DOWN (REAR MOTOR PORT)
- PORT #2: HOIST UP (FRONT MOTOR PORT)
- PORT #3: ROTATION CCW (UPPER MOTOR PORT)
- PORT #4: ROTATION CW (LOWER MOTOR PORT)
- PORT #5: LIFT CYL EXTEND
- PORT #6: LIFT CYL RETRACT
- PORT #7: EXT CYL EXTEND
- PORT #8: EXT CYL RETRACT

CYLINDER SEAL KIT: 470016001
C'BAL CARTRIDGE: 360153001

14005H PEDESTAL ASSEMBLY HARDWIRED - P/N: 470030002

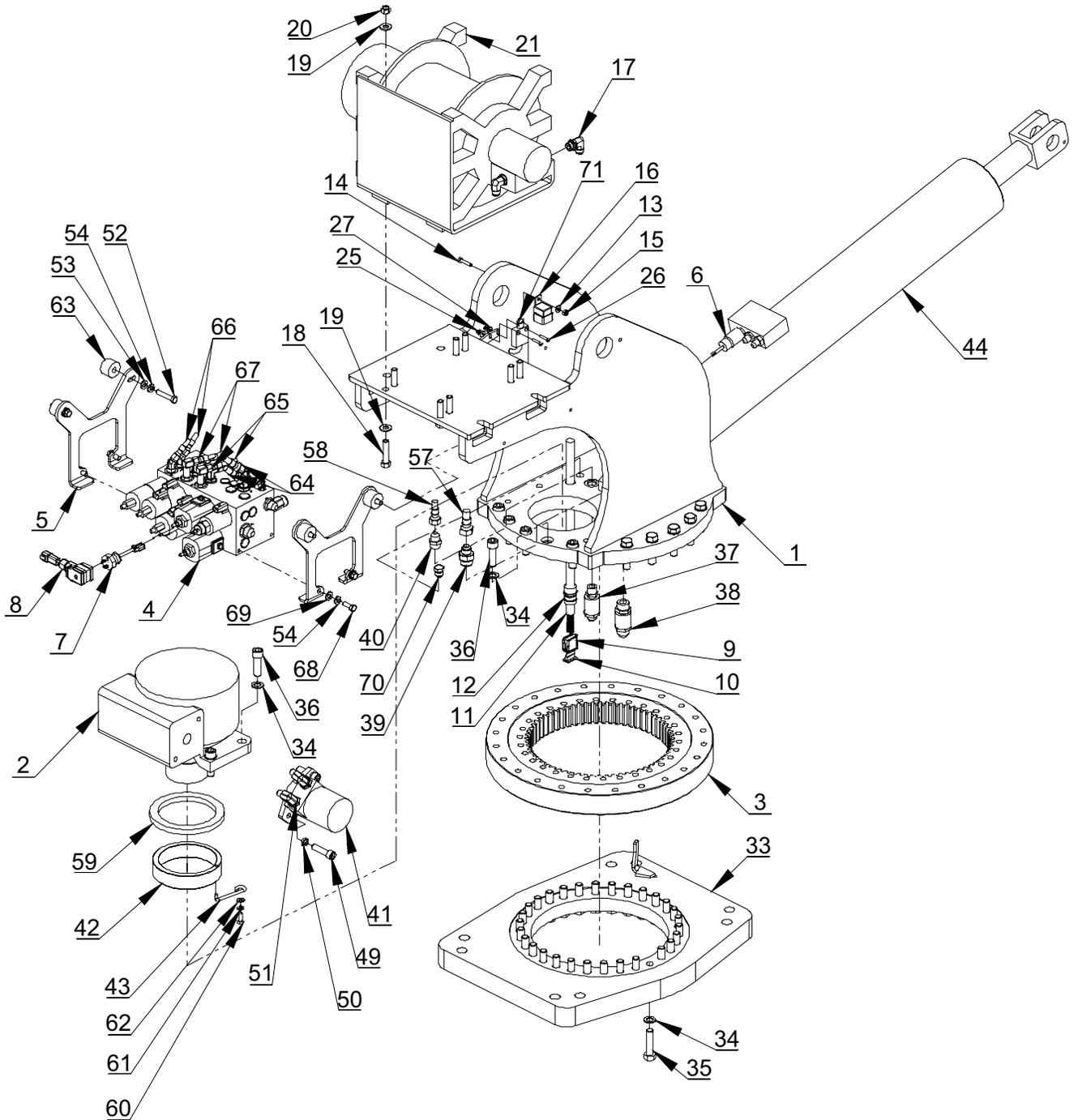

14005H PEDESTAL ASSEMBLY HARDWIRED - P/N: 470030002

ITEM NO.	QTY.	PART NO.	DESCRIPTION
1	1	470031000	PEDESTAL WLDMNT, 14005
2	1	470003000	GEARBOX, ROTATION DRIVE, 42:1
3	1	470001000	BEARING, ROTATION
4	1	470007000	VALVE ASSY, 6GPM DIVIDER, PROP, UNLOAD, 14005
5	2	366364000	PLATE, VALVE MOUNTING
6	1	460096000	LOAD SENSOR SWITCH, 2850 PSI
7	1	470011000	CABLE ASSY, AMP TO 2-PIN DEUTSCH
8	1	470010000	AMPLIFIER ASSY, 4-PIN DEUTSCH
9	1	366522001	HOUSING, PLUG, DEUTSCH 12-PIN
10	1	366522002	WEDGE, DEUTSCH PLUG, 12 SOCKET
11	1	470038000	MAIN HARNESS ASSEMBLY, HARD WIRED
12	1	366698000	CORD GRIP .375-.500 3/4" HUB
13	2	020300000	WASHER FL 1/4
14	1	006200000	SCREW HX HD 1/4-20UNC X 1 1/4 LG
15	1	016300000	NUT HX NYLK 1/4-20UNC
16	1	320355000	RELAY, BOSCH
17	2	362020000	FITTING 90 8 SAE/8 JIC
18	8	366391000	HEX HD 1/2-13 X 2 1/4
19	16	320588000	WASHER FL 1/2
20	8	017701000	NUT HX 1/2-13UNC
21	1	470004000	WINCH, PLANETARY, 7000 LB
22	1	470035000	PLATE, ROTATION STOP
23	1	366676000	COVER, ROTATION STOP
24	1	460110000	ROTATION STOP SWITCH ASSEMBLY
25	6	015801000	NUT HX NYLON LOCK #10-24UNC ZP
26	6	460093000	SCREW RD HD SL #10-24UNC X 1 LG ZP
27	6	020000000	WASHER FL #10 ZP
28	1	366673000	PIN, ROTATION STOP
29	2	017301000	NUT HX NYLK 3/8-16UNC CP
30	1	460079000	BEARING, ROTATION STOP
31	1	366675000	WASHER, NYLON
32	1	366671000	ARM, ROTATION STOP
33	1	470033000	BASE WLDMNT, 14005
34	53	023902000	WASHER FL 5/8 HARDENED
35	44	366393000	SCREW HX HD 5/8-11UNC X 2 1/2 LG GR8
36	9	470046000	SCREW, SOCKET HD, 5/8-11 X 2.0L
37	1	366358000	FITTING 10SAE/JIC SWIVEL PS810503-10-10
38	1	460086000	FITTING 12 SAE/JIC SWIVEL
39	1	372260000	FITTING, 10-12 JIC/SAE STR
40	1	372041000	FITTING 8JIC/10SAE STRAIGHT 8-10 F5OX
41	1	366440000	ROTATION MOTOR
42	1	470005000	ECCENTRIC RING, 14005
43	1	360207000	RETAINER ECCENTRIC RING
44	1	470016000	CYLINDER, LIFT
45	1	470024000	BEARING, SPHERICAL 1-1/2"PIN
46	2	202756000	FITTING, -6JIC/-8SAE STR
47	1	470077000	PIN, CYLINDER 1.5 OD

14005H PEDESTAL ASSEMBLY HARDWIRED - P/N: 470030002

ITEM NO.	QTY.	PART NO.	DESCRIPTION
48	1	239300000	ZERK, GREASE
49	2	009118000	SCREW SOC HD 1/2-13UNC X 2 LG
50	2	021502000	WASHER SP LK 1/2 HI COLLAR
51	2	490198000	FITTING 10SAE(M)/6 JIC ELBOW 90
52	4	009116000	SCREW HX HD 3/8-16UNC X 2 GR5
53	5	320976000	WASHER, FLAT, 3/8 SAE HARDENED
54	9	021100000	WASHER SP LK 3/8
55	1	008702000	SCREW HX HD 3/8-16UNC X 1 1/4 LG GR5
56	1	360677000	PIN, 1/4 COTTERLESS RING
57	1	812409-024	HOSE ASSY 10 STR/90
58	1	812309-024	HOSE ASSY 8 STR/90
59	1	470006000	SEAL, 6.75OD, ROTATION BOX
60	1	007807000	SCREW HX HD 5/16-18UNC X 3/4 LG GR5
61	1	020601000	WASHER SP LK 5/16
62	1	020901000	WASHER FL 5/16
63	4	404214000	SPACER, HYD TANK
64	2	480203000	HOSE ASSY 8 STR X 24.75
65	2	480205000	HOSE ASSY 6 STR X 19.25
66	2	812203024	HOSE ASSY 6 JICF STR
67	2	812203038	HOSE ASSY 6 STR
68	4	330371000	SCREW HX HD 3/8-16UNC X 1 LG GR8
69	4	021200000	WASHER FL 3/8
70	1	360883000	FITTING, PLUG -8 JIC
71	1	460112000	BOOM LIMIT SWITCH ASSEMBLY, HW
*72	1	374086000	NYLON HOSE SLEEVE
*	ITEMS NOT SHOWN		

14005H BOOM ASSEMBLY

P/N: 470050000

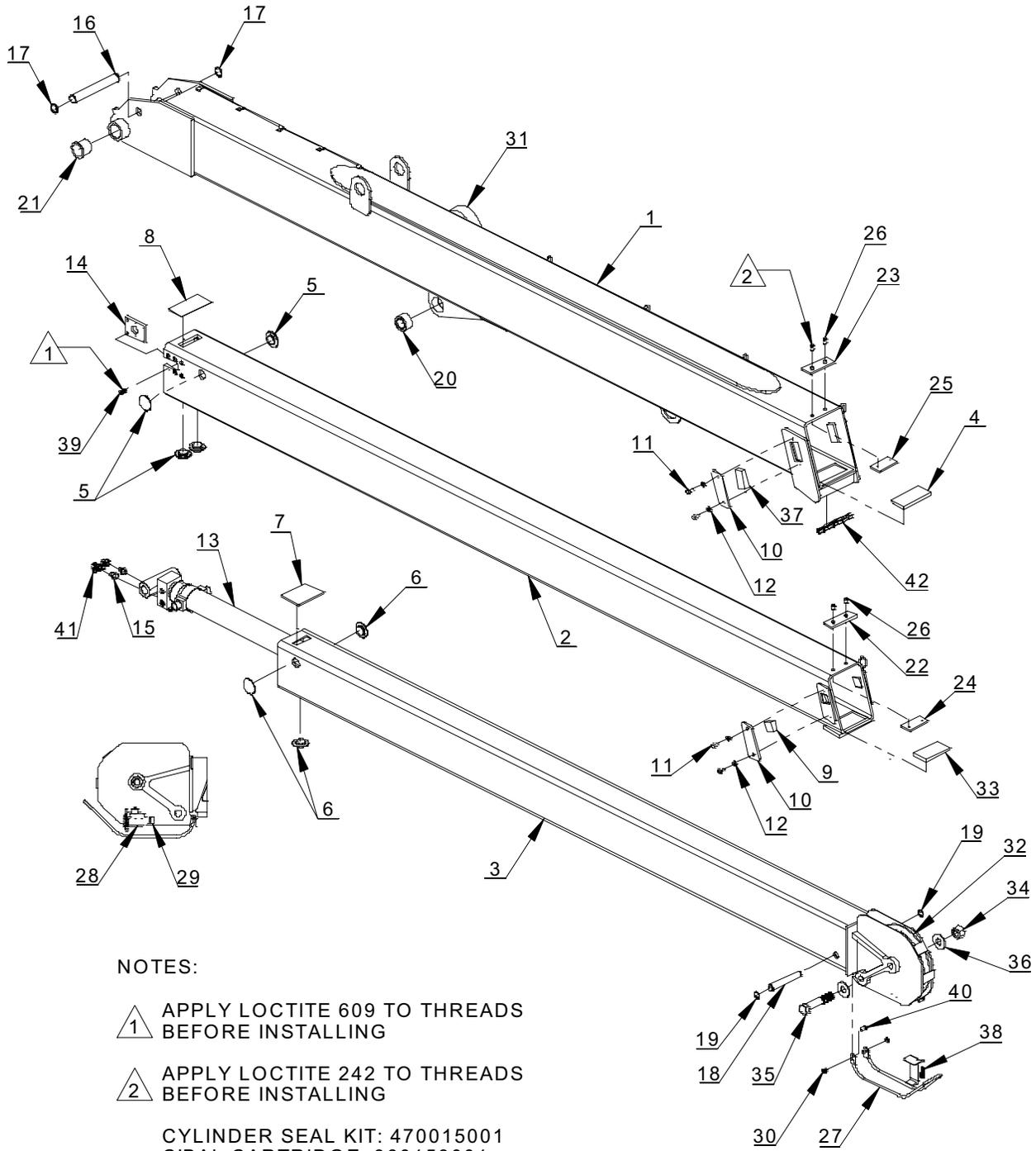

14005H BOOM ASSEMBLY

P/N: 470050000

ITEM NO.	QTY.	PART NO.	DESCRIPTION
1	1	470055000	14005H LOWER BOOM WELDMENT
2	1	470053000	14005H MID BOOM WELDMENT
3	1	470051000	14005H BOOM WELDMENT UPPER
4	1	366187000	PAD LOWER, 6006H
5	4	407202000	PAD BOOM 2.50 O.D.
6	3	470048000	PAD, BOOM 2.50 O.D. X 0.063 THICK
7	1	470057000	WEAR PAD TOP UPPER - 1/8" THICK
8	1	470058000	WEAR PAD, TOP MID 3/16"THICK
9	2	366351000	PAD, WEAR 1 1/2 X 1 1/2 X .84
10	4	366385000	PLATE, LOWER BOOM PAD COVER
11	8	008400000	SCREW HX HD 3/8-16UNC X 3/4 LG GR 5
12	8	021100000	WASHER SP LK 3/8
13	1	470015000	CYLINDER, EXTENSION 3" BORE 204" STROKE
14	2	470082000	RETAINER EXTENSION CYLINDER 3/8"THICK
15	2	202756000	FITTING 6-8 STRAIGHT
16	1	470073000	PIN 1.25" DIA X 9.06 LG
17	2	480029000	RING RETAINING
18	1	470074000	PIN 1" DIA X 6.03 LG
19	2	360122000	RING RETAINING 5100-98
20	1	470024000	BEARING, SPHERICAL 1-1/2"PIN
21	2	366394000	BEARING, PIVOT
22	1	470084000	WEAR PAD, CABLE
23	1	460081000	WEAR PAD, CABLE
24	1	470047000	WEAR PAD RETAINER PLATE 1/8 THICK
25	1	460082000	PLATE, WEAR PAD RETAINER
26	4	460083000	SCREW SOC HD CTRS NK 5/16-24UNF X 3/4 LG
27	1	360718000	BAIL WELDMENT
28	1	646900000	SWITCH, LIMIT ANTI-TWO BLOCK
29	1	642918000	CORD CONNECTOR
30	2	016801000	NUT HX NYLK 5/16-18UNC CP
31	1	360759000	CORD REEL ASSY
32	1	470023000	SHEAVE ASSEMBLY CROWN 1/2" ROPE
33	1	460052000	WEAR PAD, BOTTOM MID
34	1	470075000	NUT, HEX NYLOCK 1-14UNF ZPL
35	1	330185000	1" BOLT - 5-1/2"LG UNF
36	2	022502000	WASHER FLAT 1 I.D. x 2.50 O.D.
37	2	366354000	WEAR PAD
38	1	366678000	SPRING, EXTENSION
39	12	470079000	3/8"-16UNC BUTTON HEAD 3/4"LG
40	2	007807000	SCREW HX HD 5/16-18UNC X 3/4 LG GR5
41	2	480194000	FITTING 6 SWIVEL NUT ELBOW
42	7 in.	470049000	EDGE TRIM 1/2

14005H ROTATION GEARBOX

P/N: 470003000

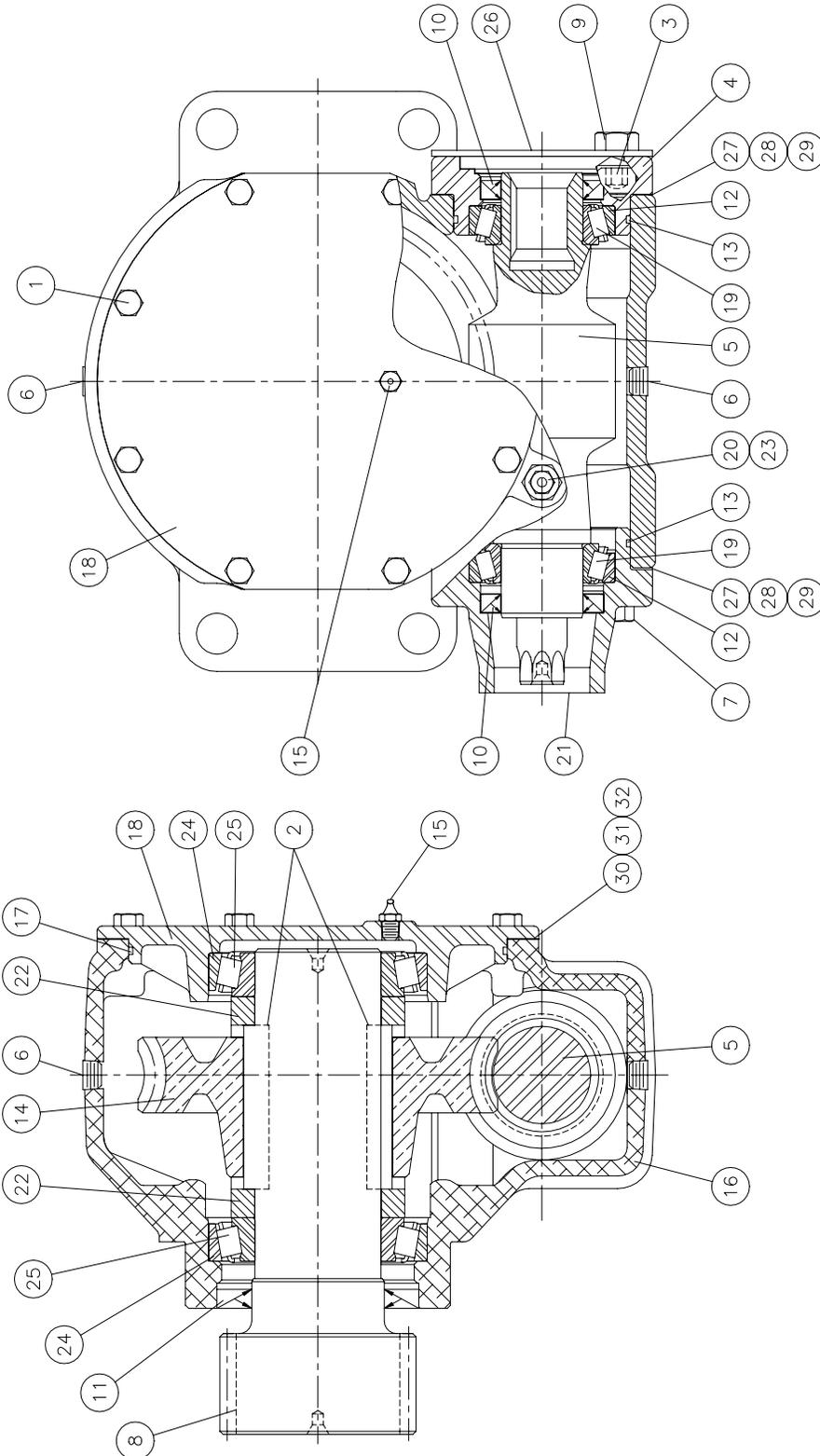

14005H ROTATION GEARBOX

P/N: 470003000

ITEM NO.	QTY.	PART NO.	DESCRIPTION
1	8	470003001	CAPSCREW
2	2	470003002	KEY
3	2	470003003	CAPSCREW, SOCKET HEAD
4	1	470003004	CAP, END, MOTOR
5	1	470003005	WORM, SL
6	2	470003006	PLUG, PIPE
7	4	470003007	CAPSCREW
8	1	470003008	SHAFT, OUTPUT
9	2	470003009	CAPSCREW
10	2	470003010	SEAL, OIL
11	1	470003011	SEAL, OIL
12	2	470003012	CUP, BEARING
13	2	470003013	O-RING
14	1	470003014	GEAR, WORM, SL
15	1	470003015	FITTING, GREASE
16	1	470003016	HOUSING
17	1	470003017	O-RING
18	1	470003018	COVER
19	2	470003019	CONE, BEARING
20	1	470003020	BREATHER
21	1	470003021	CAP, END
22	2	470003022	SPACER, BEARING
23	1	470003023	BUSHING, PIPE
24	2	470003024	CUP, BEARING
25	2	470003025	CONE, BEARING
26	1	470003026	PROTECTOR
27	2	470003027	SHIM, G1600D, CLEAR (.005)
28	2	470003028	SHIM, G1600D, BROWN (.010)
29	2	470003029	SHIM, G1600D, YELLOW (.020)
30	1	470003030	SHIM, G1600D, CLEAR (.005)
31	1	470003031	SHIM, G1600D, BROWN (.010)
32	1	470003032	SHIM, G1600D, YELLOW (.020)

14005H HOIST ASSEMBLY

P/N: 123416

ITEM NO.	QTY.	PART NO.	DESCRIPTION
49	1	518037	THRUST WASHER
50	1	518047	THRUST WASHER
51	1	518052	THRUST WASHER
52	1	518053	THRUST WASHER (MOTOR END)
53	1	518054	THRUST WASHER (GEAR HOUSING END)
54	1	362298	SPACER-MOTOR

**NOTE: SEE APPENDIX FOR INFORMATION REGARDING PEDESTAL ASSEMBLY AND WINCH SUPPLIED ON UNITS 1-10.
(SERIAL NUMBERS: 14005HP0406001 THRU 14005HP0606010)**

14005H TRAVELING BLOCK ASSEMBLY

P/N: 470025000

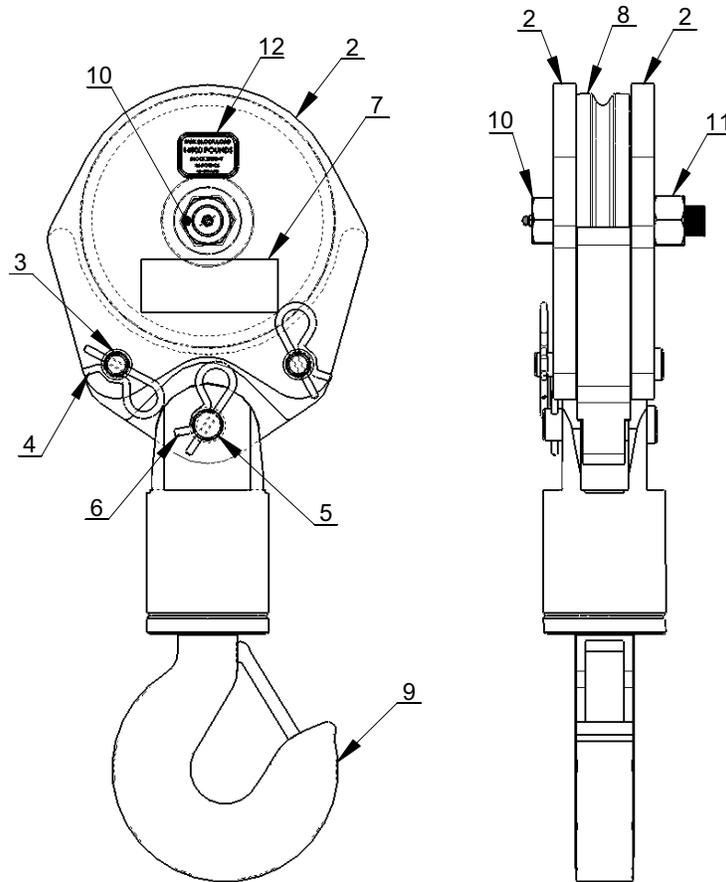

ITEM NO.	QTY.	PART NO.	DESCRIPTION
1	1	470027000	14005H TACKLE LOWER
2	2	470026000	14005H TRAVELING BLOCK SIDE PLATE
3	2	470014000	PIN 3/4 X 3.94 LG
4	2	366813000	PIN HITCH
5	1	470013000	PIN, SWIVEL HOOK
6	1	360124000	PIN HITCH
7	2	040518000	DECAL STAY CLEAR OF LOAD
8	1	470022000	SHEAVE ASS'Y, BLOCK 1/2" ROPE
9	1	470018000	HOOK, SWIVEL 8 METRIC TON
10	1	470012000	BOLT, SHEAVE W/ZERK FITTING 1-14UNF
11	1	470075000	NUT, HEX NYLOCK 1-14UNF ZPL
12	2	470044000	DECAL MAX BLOCK LOAD

14005H ELECTRICAL SCHEMATIC HARDWIRED – P/N: 470093001

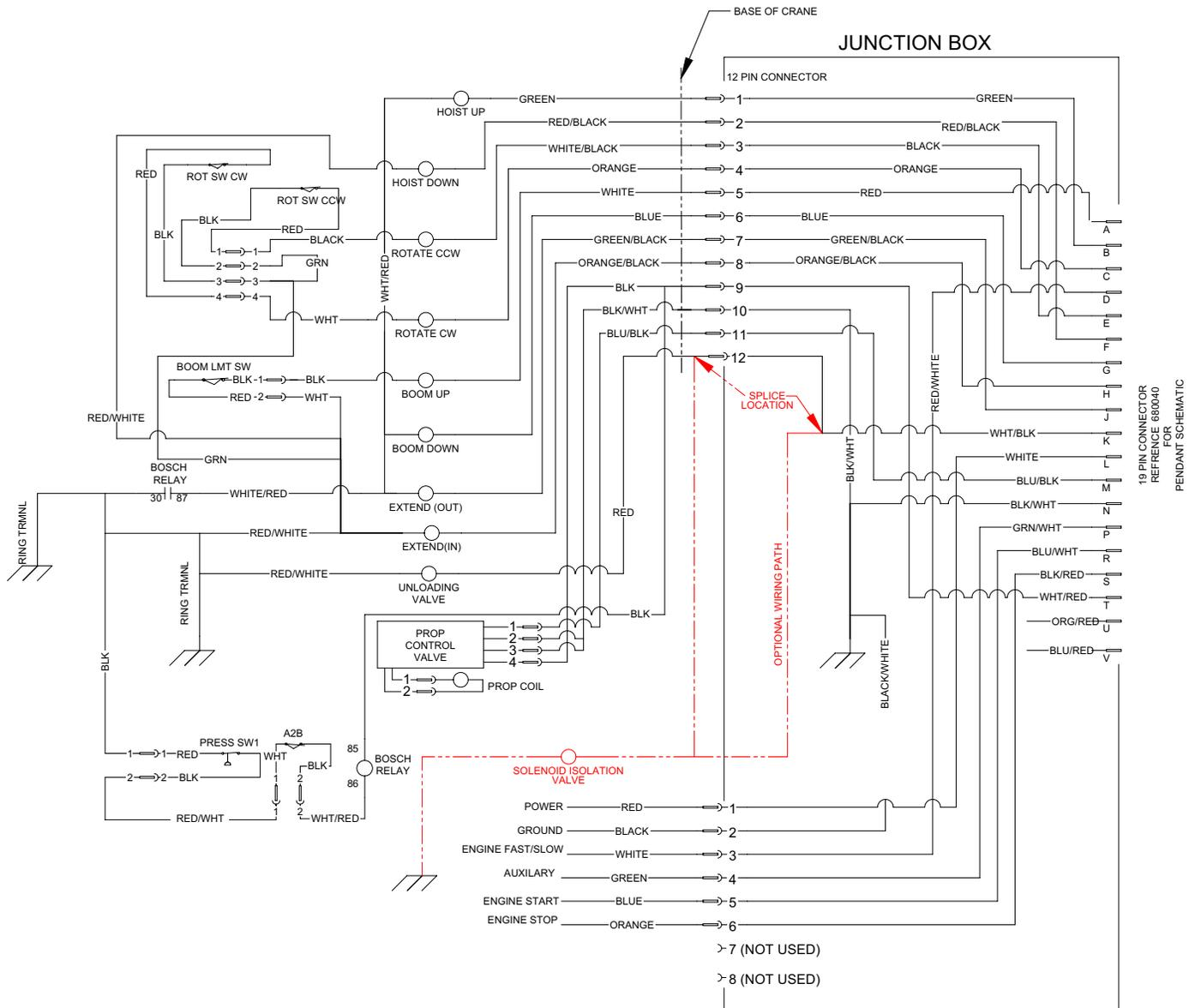

14005H MAIN WIRING HARNESS HARDWIRED – P/N: 470038000

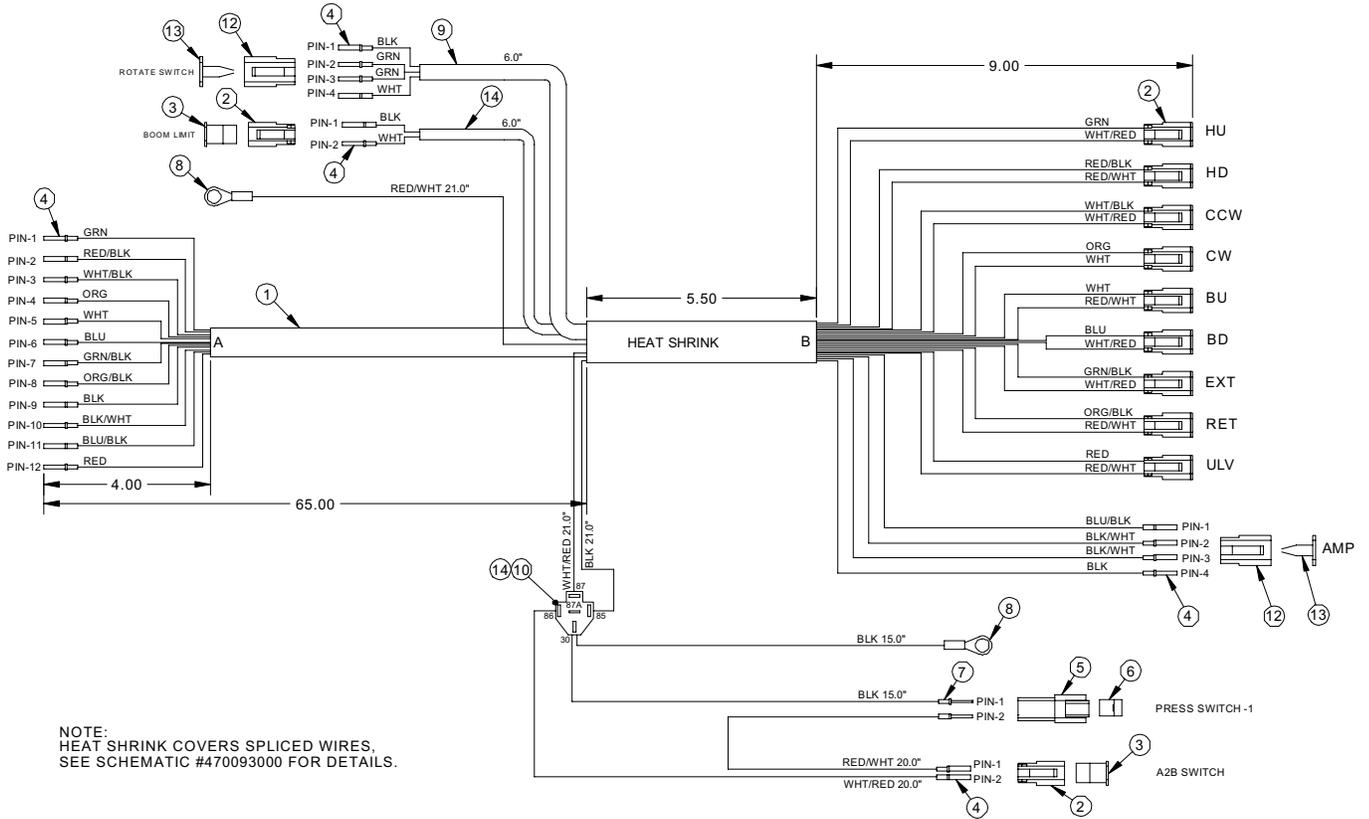

ITEM NO.	QTY.	PART NO.	DESCRIPTION
1	REF.		CABLE, 18/12 GRAY PVC JACKET
2	11	366367001	HOUSING, DEUTSCH 2-PIN PLUG
3	11	366367002	WEDGE, DEUTSCH PLUG, 2 PIN
4	42	366367003	CONTACT, DEUTSCH SOCKET
5	1	360769001	HOUSING, DEUTSCH 2-PIN RECEPTACLE
6	1	360769002	WEDGE, DEUTSCH 2-PIN RECEPTACLE
7	2	366376003	CONTACT, DEUTSCH
8	2	501000000	TERMINAL RING, 5/16, 14-16 GA
9	REF.	800628000	WIRE, 3 CONDUCTOR
10	1	320363000	PLUG TERMINAL CONNECTOR
11	4	320357000	FEMALE SPADE, NON-INSULATED
12	2	320931001	HOUSING, DEUTSCH 4-PIN PLUG
13	2	320931002	WEDGE, DEUTSCH 4-PIN PLUG
14	REF.	800626000	WIRE, 2 CONDUCTOR

FUNCTION	PIN	WIRE COLOR	NOTES
HOIST UP	1	GREEN	TO PIN 1 (MAIN)
	2	WHITE/RED	TO A2B GROUND
HOIST DN	1	RED/BLACK	TO PIN 2 (MAIN)
	2	RED/WHITE	GROUND
ROTATE CCW	1	WHITE/BLACK	TO PIN 3 (MAIN)
	2	BLACK	TO PIN 1 (ROTATE SWITCH)
ROTATE CW	1	ORANGE	TO PIN 4 (MAIN)
	2	WHITE	TO PIN 4 (ROTATE SWITCH)
BOOM UP	1	WHITE	TO PIN 5 (MAIN)
	2	RED/WHITE	GROUND
BOOM DN	1	BLUE	TO PIN 6 (MAIN)
	2	WHITE/RED	TO A2B GROUND
EXTEND	1	GREEN/BLACK	TO PIN 7 (MAIN)
	2	WHITE/RED	TO A2B GROUND
RETRACT	1	ORANGE/BLACK	TO PIN 8 (MAIN)
	2	RED/WHITE	GROUND
A2B SWITCH	1	RED/WHITE	TO PIN 2 (PRESS SWITCH-1)
	2	WHITE/RED	TO PIN 87 (RELAY)
PRESSURE SWITCH	1	BLACK	GROUND
	2	RED/WHITE	TO PIN 1 (A2B SWITCH)
ROTATE SWITCH 3 COND CABLE	1	BLACK	TO PIN 2 (CCW)
	2,3	GREEN	GROUND
	4	WHITE	TO PIN 2 (CW)
PROPORTIONAL VALVE	2	BLACK/WHITE	TO PIN 10 (MAIN)
	3	BLUE/BLACK	TO PIN 11 (MAIN)
	4	BLACK	TO PIN 9 (MAIN)
	5	BLACK/WHITE	TO PIN 10 (MAIN)
UNLOADING VALVE	1	RED	TO PIN 12 (MAIN)
	2	RED/WHITE	GROUND
BOOM LIMIT	1	BLACK	TO PIN 2 (BOOM UP)
	2	WHITE	GROUND

14005H JUNCTION BOX ASSEMBLY HARDWIRED - P/N: 366520002

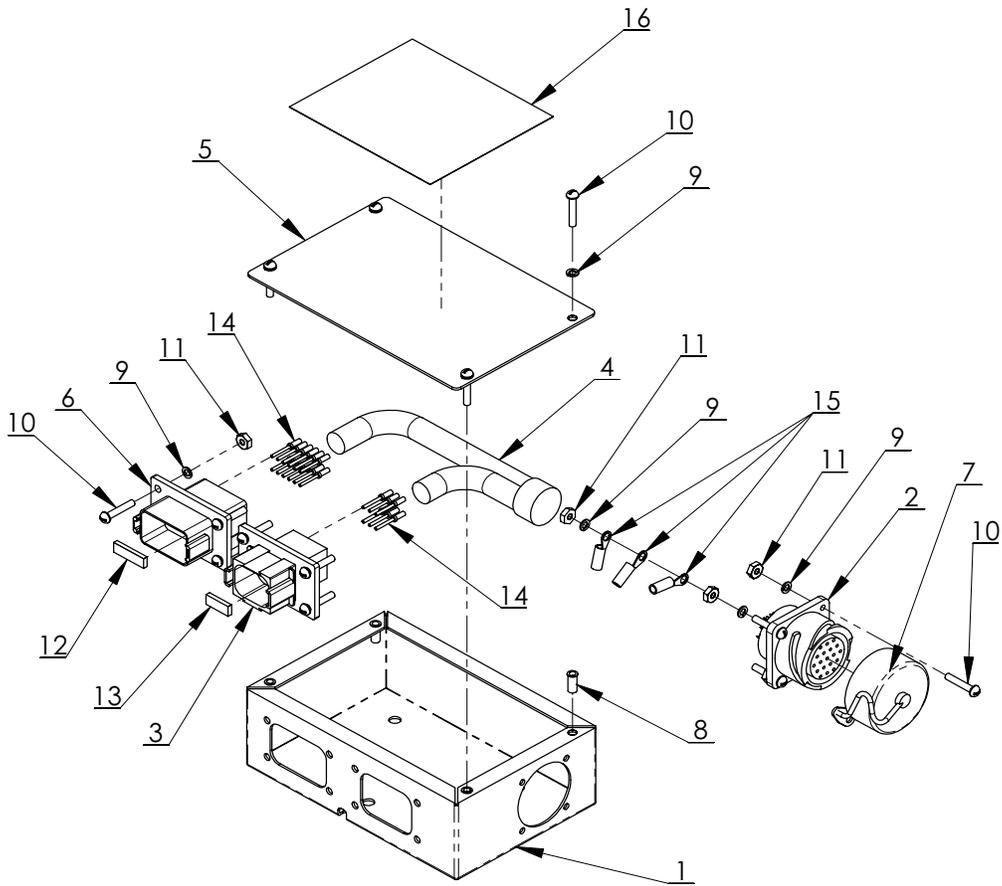

19 PIN	8 PIN	12 PIN	GND	WIRE COLOR	WIRE CUT LENGTH
A		5		RED	6.5
B		1		GREEN	6.5
C		4		ORANGE	6.5
D	3			RED/WHITE	4.0
E		3		BLACK	6.5
F		2		RED/BLACK	6.5
G		6		BLUE	6.5
H		8		ORANGE/BLACK	6.5
J		7		GREEN/BLACK	6.5
K	-	12		WHITE/BLACK	6.5
L	1			WHITE	4.0
M		11		BLUE/BLACK	6.5
N			GND	BLACK/WHITE	5.5
P	4			GREEN/WHITE	4.0
R	5			BLUE/WHITE	4.0
S	6			BLACK/RED	4.0
T		9		WHITE/RED	6.5
U	-	-		NOT USED	N/A
V	-	-		NOT USED	N/A
		10	GND	BLACK/WHITE	3.0
	2		GND	BLACK/WHITE	5.0

14005H JUNCTION BOX ASSEMBLY HARDWIRED - P/N: 366520002

ITEM NO.	QTY.	PART NO.	DESCRIPTION
1	1	366470000	JUNCTION BOX
2	1	366095000	PLUG, 19 PIN
3	1	366523001	HOUSING, DEUTSCH 8-PIN RECEPTACLE
4	1	480594001	CABLE, PENDANT, 16/10 SO BLACK
5	1	366471000	COVER, JUNCTION BOX
6	1	366524001	HOUSING, DEUTSCH 12-PIN RECEPTACLE
7	1	366097000	CAP W/CHAIN (FOR RECEPTACLE)
8	4	366517000	RIVET NUT, 6-32
9	17	019600000	WASHER SP LK #6
10	16	001004000	SCREW PN HD #6 X 3/4 LG
11	13	015400000	NUT HX #6-32
12	1	366524002	WEDGE, DEUTSCH RECEPTACLE, 12 PIN
13	1	366523002	WEDGE, DEUTSCH RECEPTACLE, 8 PIN
14	18	366376003	CONTACT, DEUTSCH
15	3	000101000	TERMINAL RING, 5/32, 14-16 GA
16	1	366469001	DECAL

14005H PENDANT ASSEMBLY HARDWIRED - P/N: 680040000

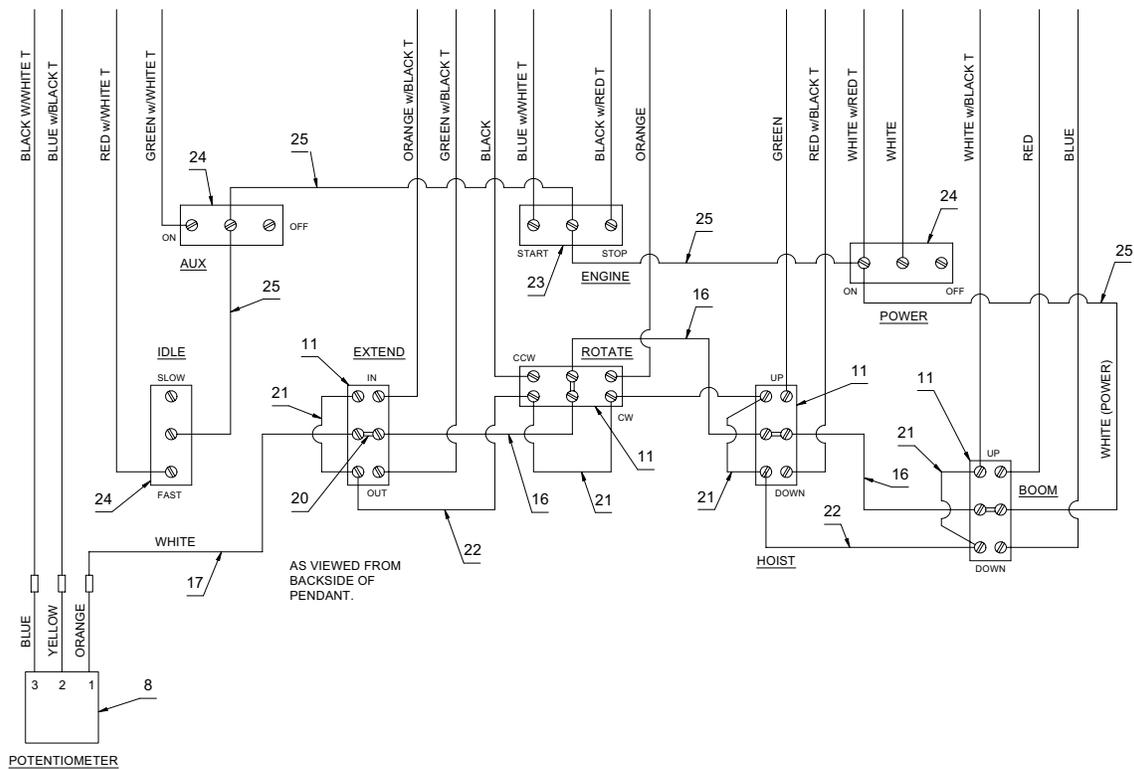
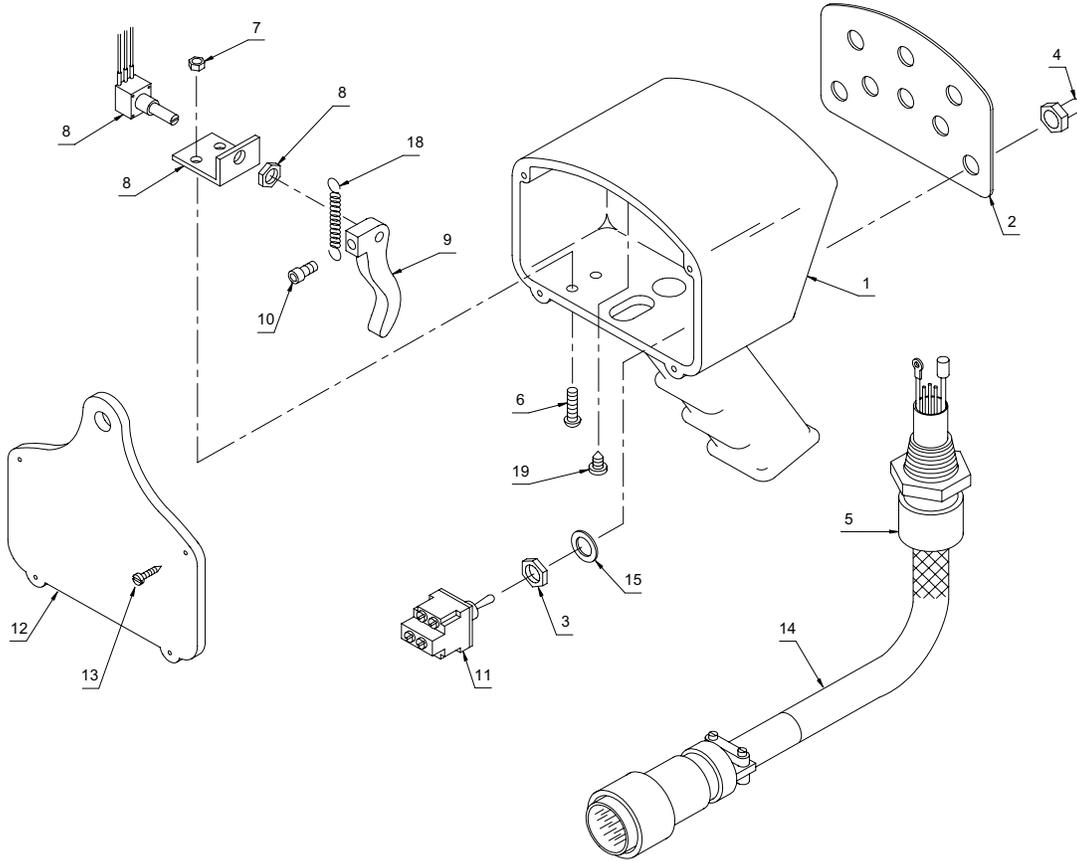

14005H PENDANT ASSEMBLY HARDWIRED - P/N: 680040000

ITEM NO.	QTY.	PART NO.	DESCRIPTION
1	1	480501000	HOUSING, PROP. PENDANT MACHINED
2	1	480518000	DECAL/COVER PLATE
3	8	REF	NUT (INCLUDED WITH SWITCH)
4	8	640300000	BOOT, TOGGLE
5	1	480567000	CORD GRIP, HUBBELL CONNECTOR
6	2	002607000	SCREW, HX HD #10-24 NC X 3/4 LG
7	2	015801000	NUT, HEX, LOCKING, #10-24 NC
8	1	480507000	POTENTIOMETER ASSEMBLY
9	1	480506000	TRIGGER
10	1	480517000	SCREW, SOC HD, #10-32 NF X 5/8 LG
11	4	634200000	SWITCH, TOGGLE DPDT
12	1	480504000	BACK PLATE, HOUSING
13	4	001004000	SCREW, PAN HD, #6-32 X 3/4 LG
14	1	680113000	CABLE ASSEMBLY, BAYONET
15	8	REF	WASHER, LOCK (INCLUDED WITH SWITCH)
16	3	660302000	CONDUCTOR ASSEMBLY
17	1	480524000	CONDUCTOR ASSEMBLY
18	1	480523000	SPRING, TRIGGER RETURN
19	1	005003000	SCREW, S.T. PAN HD, #6-32 X 3/8 LG
20	4	636600000	JUMPER
21	4	622346000	CONDUCTOR ASSEMBLY
22	3	622347000	CONDUCTOR ASSEMBLY
23	1	622000000	SWITCH, TOGGLE SPDT
24	3	750090000	SWITCH, TOGGLE ON/OFF
25	1	480526000	CONDUCTOR ASSEMBLY
26	2	750737000	TIE, CABLE

14005H PENDANT CABLE ASSEMBLY HARDWIRED - P/N: 680113000

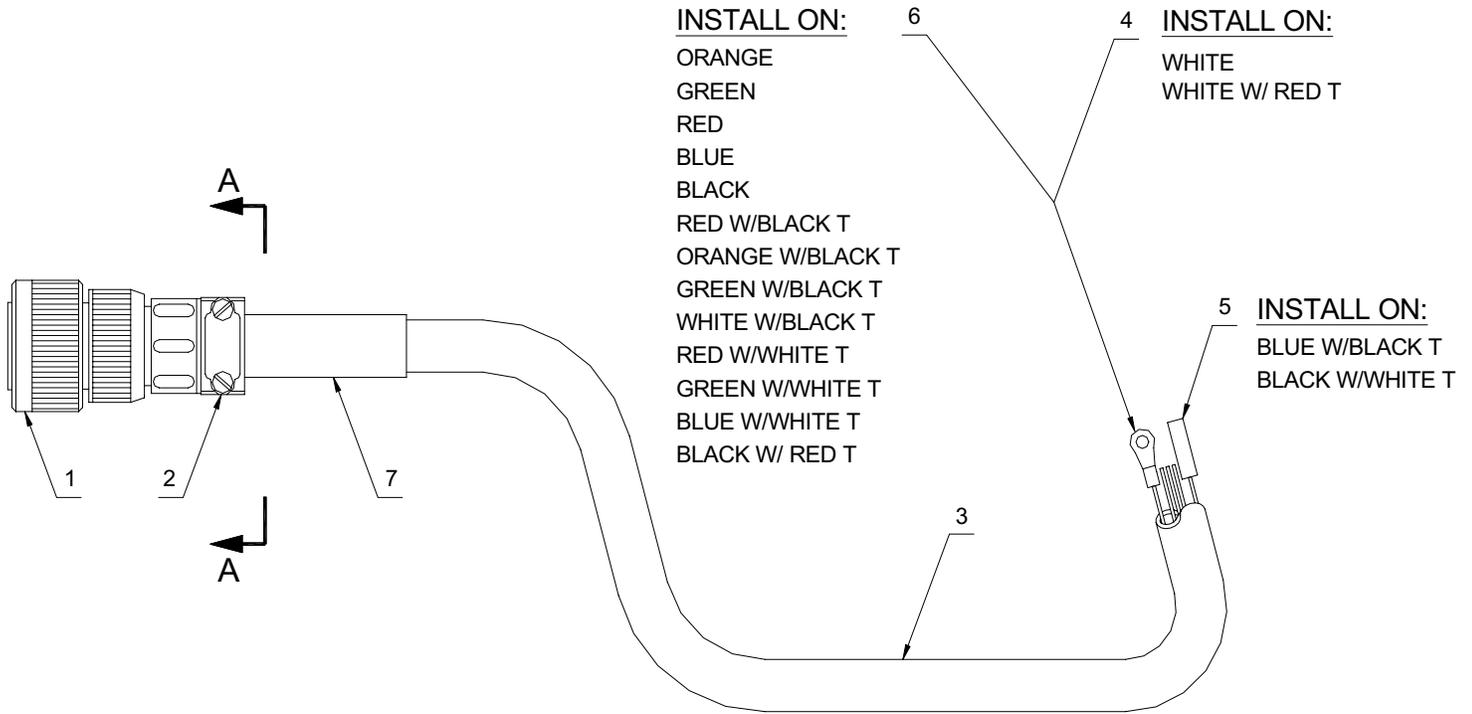

WIRING GUIDE

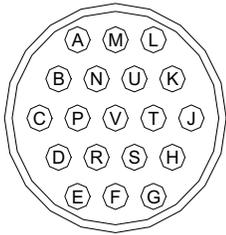

VIEW A-A

- | | |
|--------------------|-------------------|
| A-RED | L-WHITE |
| B-GREEN | M-BLUE W/BLACK T |
| C-ORANGE | N-BLACK W/WHITE T |
| D-RED W/WHITE T | P-GREEN W/WHITE T |
| E-BLACK | R-BLUE W/WHITE T |
| F-RED W/BLACK T | S-BLACK W/RED T |
| G-BLUE | T-WHITE W/RED T |
| H-ORANGE W/BLACK T | U-ORANGE W/RED T |
| J-GREEN W/BLACK T | V-BLUE W/RED T |
| K-WHITE W/BLACK T | |

ITEM NO.	QTY.	PART NO.	DESCRIPTION
1	1	366098000	PLUG, CONNECTOR
2	1	480515000	CLAMP, CABLE
3	30'	480594000	CABLE, CONDUCTOR (19 COND)
4	2	000101000	TERMINAL RING #6 / 14-16 GA
5	2	480510000	CONNECTOR, BULLET, FEMALE
6	13	002012000	TERMINAL RING #6 / 18-22 GA
7	6"	490243000	TUBING, HEAT SHRINK

14005H PROPORTIONAL VALVE CONTROLLER HARDWIRED - P/N: 366363002

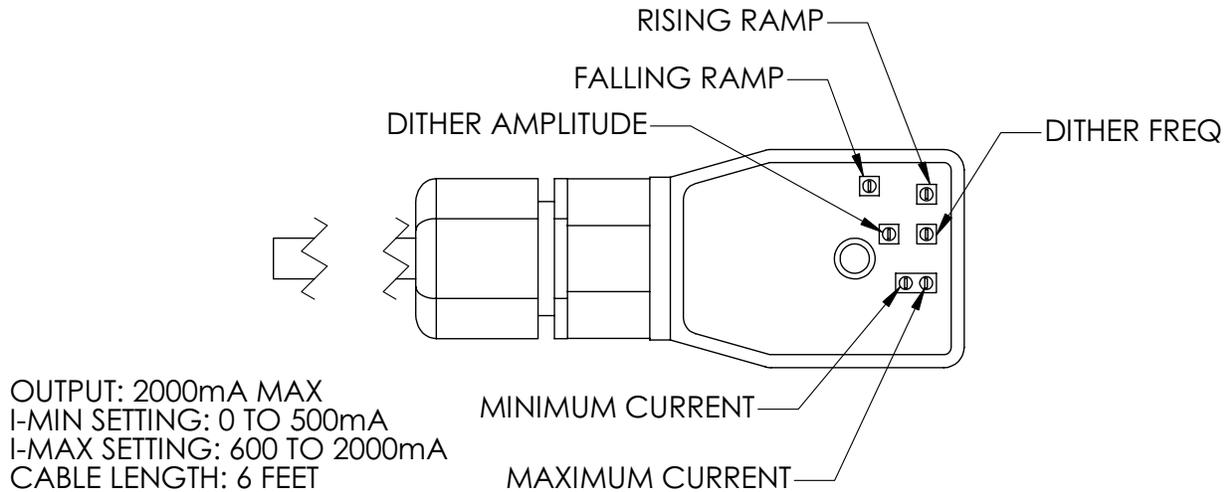

MINIMUM CURRENT ADJUSTMENTS

Current is factory set at 150 mA, no adjustment required at installation. If adjustment is required, set the minimum current before setting the maximum current. Apply minimum input (0 VDC). If the desired minimum current is greater, adjust the trim pot CW until the desired current is achieved.

MAXIMUM CURRENT

Current is factory set at 1600 mA, no adjustment required at installation. If adjustment is required, apply maximum control (5 VDC). Turn the trim pot CCW to adjust the current setting downwards to the desired minimum.

RAMP AND DITHER

Ramp and dither is adjusted at the factory and does not require any further adjustment.

NOTES

14005H HYDRAULIC CONTROL VALVE

P/N: 470007000

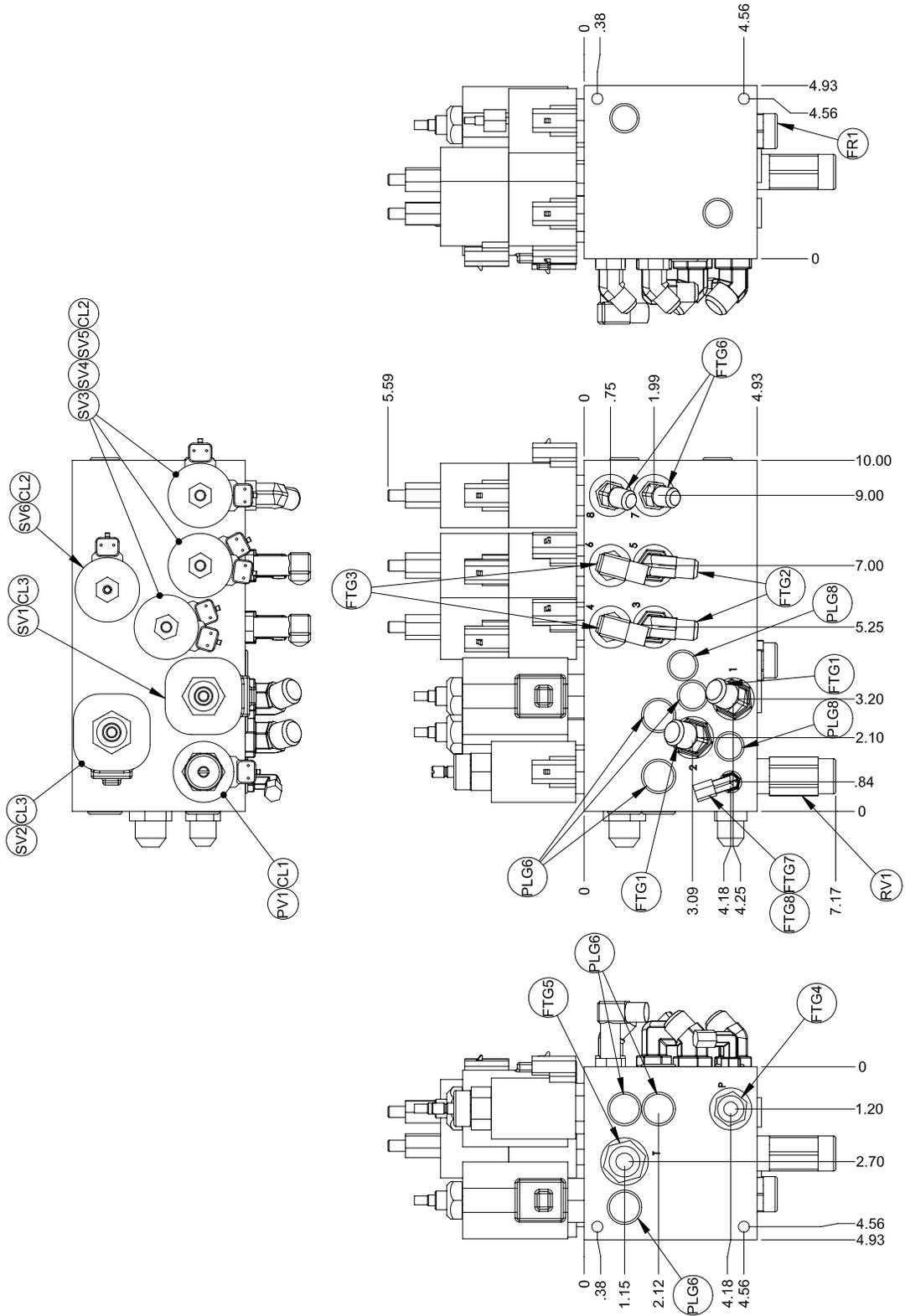

14005H HYDRAULIC CONTROL VALVE

P/N: 470007000

ITEM NO.	QTY.	PART NO.	DESCRIPTION
FR1	1	470008000	FLOW CONTROL
PV1	1	480839003	PROP VALVE
RV1	1	366365004	RELIEF VALVE
SV6	1	460160001	UNLOAD VALVE
SV1,SV2	2	480839004	CART VALVE
SV3,SV4,SV5	3	320725001	CART VALVE
CL1	1	366370001	COIL
CL2	7	366760001	COIL
CL3	2	480839005	COIL
FTG1	2	374017000	FITTING
FTG2	2	241175000	FITTING
FTG3	2	330645000	FITTING
FTG4	1	367145000	FITTING
FTG5	1	490199000	FITTING
FTG6	2	480195000	FITTING
FTG7	1	369127000	FITTING
FTG8	1	330348000	FITTING
ORF1	1		PLUG ORIFICE
PLG6	7		PORT PLUG
PLG8	11		PORT PLUG
NOT SHOWN	3		PLUG
NOT SHOWN	10		PLUG
BLK	1		BLOCK

14005H

COUNTERBALANCE VALVE ADJUSTMENT

Counterbalance Valve Adjustment

1. With PTO disengaged and boom properly supported, remove the plug on the counterbalance valve. Install a pressure gauge (0-3000 PSI) into the port.
2. Engage PTO and insure pump flow is 8 to 9 GPM. With no load on boom, boom up to an angle of 70 degrees. Boom down and note pressure. If pressure reading is not approximately 1300 PSI, the counterbalance valve requires adjustment.
 - A. To increase the CB valve setting, loosen nut and turn Allen head screw counter clockwise.
 - B. To reduce the CB valve setting, loosen nut and turn Allen head screw clockwise.
3. Tighten nut on adjustment screw and repeat procedure if needed to obtain the proper pressure setting.
4. Disengage PTO, remove the pressure gauge and install plug. Crane is now ready for operation.

Notice:

1. In an **EMERGENCY** situation when it becomes necessary to lower the boom without flow present, the CB valve adjustment can be turned in until the boom begins to descend. Make sure the boom will lower onto a proper support. Loosen the lock nut and carefully turn adjustment screw clockwise! Count the number of turns. *Turn slowly until the boom just begins to lower, and remove hand/arm/fingers from cranes while boom is lowering.*
2. Turning adjustment screw too far will cause valve to come apart on the inside. This condition is not repairable
3. After boom is lowered, turn adjustment screw counter clockwise the approximate number of turns made during lowering procedure. After the problem is corrected, readjust the counterbalance valve using the procedure in this manual.

WARNING:

**DO NOT TRY TO ADJUST VALVES WHILE BOOM IS MOVING.
Doing so may result in personal injury!**

14005H VALVE OVERRIDE OPERATION

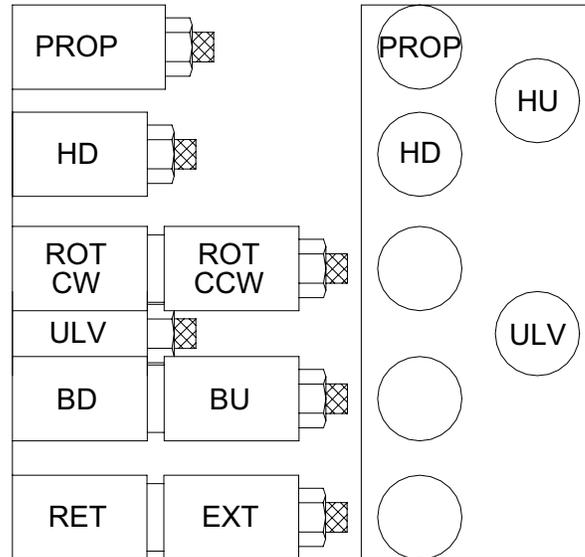

DIRECTIONAL CONTROL VALVE IDENTIFICATION

In the event that the electrical control system fails the crane can be operated using the manual overrides on the hydraulic control valve.

The overrides operate as follows:

1. Proportional – increase flow by turning clockwise.
2. Extend/Retract, Boom Up/Down, Rotate CW/CCW – push to operate boom down, pull to operate boom up etc. See graphics above.
3. Hoist Up/Down, Unload Valve – Push in to operate.

Note: To manually activate a function the crane with no electrical power, you must first turn manual override on proportional clockwise then push in the unload valve while pushing or pulling the function you want to activate.

14005H LOAD CHART

P/N: 470042000

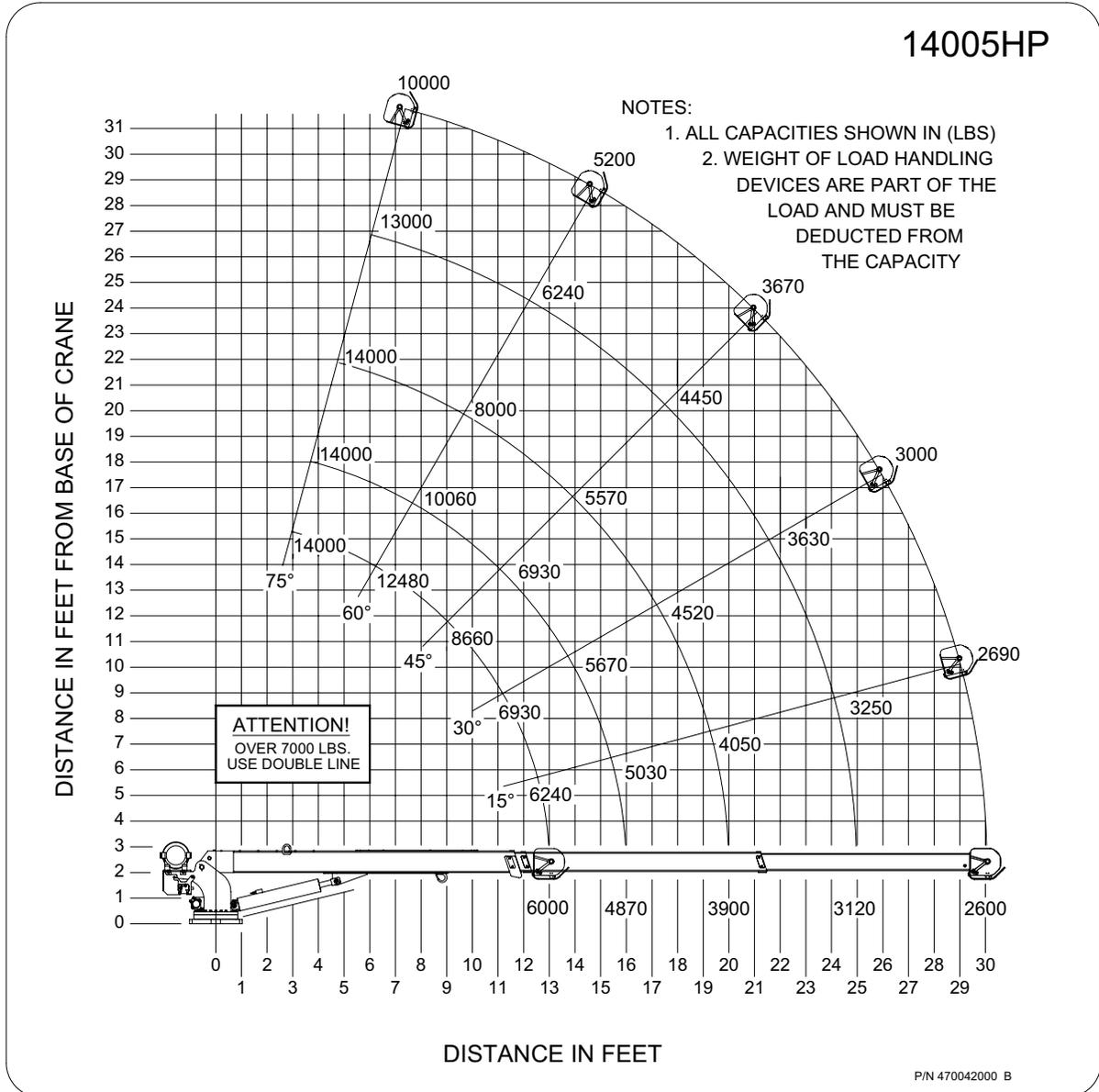



P.O. Box 580697 * Tulsa, OK 74158-0697
4707 N. Mingo Rd. * Phone (918) 836-0463

LIMITED WARRANTY 2 YEAR PARTS AND LABOR

Auto Crane will warranty to the consumer for a period of (2) years parts and labor from the date of purchase. Each new Auto Crane unit they sell will be free under normal use and service from defects in material and workmanship. Date of purchase will be honored as the date indicated on the Bill of Sale, which must accompany the Warranty Registration and be on file with Auto Crane. Absent a valid Warranty Registration and appropriate documentation, the original date of manufacture, as indicated by the serial number on the product, will be used to determine the effective date of the 2 year warranty.

The obligation of Auto Crane under this warranty is limited to the replacement or repair of parts that appear to the manufacturer after review and/or inspection to be defective and paid flat rate labor for replacing defective parts. This warranty does not obligate Auto Crane to bear the travel time charges in connection with the replacement or repair of defective parts. Responsibility for customer's claims arising from misapplication, abuse, misuse or alteration of equipment or parts lies with the distributor or user and no warranty obligation is assumed in these circumstances by Auto Crane.

Auto Crane will in no event be liable for any consequential damages or contingent liabilities arising out of the failure of any Auto Crane Product or parts to operate properly.

Auto Crane makes no warranty in respect to component accessories, it being subject to the warranties of their respective manufacturers.

If field service, at the request of the distributor, is rendered and fault is found not to be with Auto Crane's product, the distributor shall pay the time and expense of the field representative.

Claims for service labor or other expenses that have incurred by the buyer without approval or authorization or Auto Crane will not be accepted.

When applying for warranty, claims may be handled by contacting your nearest authorized Auto Crane Distributor. All claims are to be filed in writing on an Auto Crane Warranty Claim Form.

AUTO CRANE COMPANY IS UNDER NO OBLIGATION TO EXTEND THIS WARRANTY TO ANY CUSTOMER FOR WHICH AN AUTO CRANE DELIVERY REPORT FORM HAS NOT BEEN COMPLETED AND ON FILE WITH AUTO CRANE COMPANY

APPENDIX



WINCH

A **DOVER** COMPANY

Serving the crane, tow & recovery, utility, railroad, oilfield, mining, construction, marine, fishing, forestry and other industries with quality planetary gear products since 1970.

PARTS & OPERATORS MANUAL

**HYDRAULIC WINCH
AJ8CAS1L6A-002**

Date:

Serial number:

**dp Manufacturing, Inc. ■ PO Box 471710 ■ Tulsa, OK 74147
(918) 250-2450 ■ 1-800-dp Winch ■ Fax: (918) 250-0690 ■ www.dpwinch.com**

TABLE OF CONTENTS

WARNING AND CAUTION NOTICES - READ BEFORE OPERATING PRODUCT	
OPERATING PROCEDURE FOR SHIFTING GEARS	
DIMENSIONAL – AJ8CAS1L6A-002 WINCH	
WIRE ROPE INSTALLATION	
HYDRAULIC SYSTEM	
GENERAL INFORMATION AND DP SERVICING INSTRUCTIONS	
INSTALLATION DRAWING - MOTOR END - EXPLODED VIEW	
PARTS LIST – MOTOR END.....	1.10407
INSTALLATION DRAWING - DRUM - EXPLODED VIEW	
PARTS LIST - DRUM.....	1.20149
INSTALLATION DRAWING - GEAR END - EXPLODED VIEW	
PARTS LIST - GEAR END.....	1.30133
INSTALLATION DRAWING - INPUT SHAFT - EXPLODED VIEW	
PARTS LIST - INPUT SHAFT.....	1.40287
INSTALLATION DRAWING - BASE MOUNT - EXPLODED VIEW	
PARTS LIST - BASE MOUNT.....	1.50287
INSTALLATION DRAWING - GEAR END COVER - EXPLODED VIEW	
PARTS LIST - GEAR END COVER.....	1.60112
BOLT TORQUE CHART	
WINCH / GEAR BOX LUBRICATION	
GENERAL INFORMATION	
REPAIR & REPLACEMENT PARTS ORDERING INFORMATION	
DP WINCH LIMITED WARRANTY	

GENERAL WARNING SHEET

Review entire manual before installation or operation of winch.

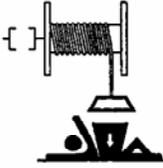
	 DANGER
	Do not disengage gear box while winch is under load. Immediate loss of load control will result.

	 DANGER
	The last five wraps of wire rope must be left on the drum to assist the wire rope clamp in holding the load.

	 DANGER
	Winches are not to be used for the lifting or moving of persons.

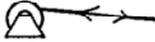
	 WARNING
	Wire rope can break without warning. Always keep a safe distance from the winch and wire rope while under a load. Consult the wire rope manufacturer for wire rope ratings and maintenance procedures.

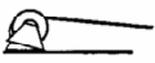
	 WARNING
	Failure to adequately align, support, or attach winch to a suitable mounting base could result in a loss of efficiency or premature failure of winch, wire rope, or mounting base.

OPERATING PROCEDURE FOR SHIFTING GEARS

The following steps are necessary for proper gear shifting operations.

Gear Dis-Engagement:

1. Winch must be "at rest" and have **no** load on cable.
2. Shift winch to out of gear "*free spool*" mode.

Gear Engagement:

1. Winch must be "at rest" and have **no** load on cable.
2. Shift winch to in-gear mode and **slowly** rotate drum 90° in pay out direction, and then **stop** rotation. Next, **slowly** rotate drum in pay in direction to insure gears are fully engaged and **begin** paying in of load.

WARNING!

If your winch has ever been "*shifted under load*" or has ever encountered "*rotational face contact of non-engaged gear components,*" the gear teeth could be damaged. Damaged gear teeth can prevent your winch from fully engaging into gear and could allow it to jump out of gear. If this has happened to your winch, this procedure may *not* insure that it is fully engaged and it may need to be inspected for possible gear damage.

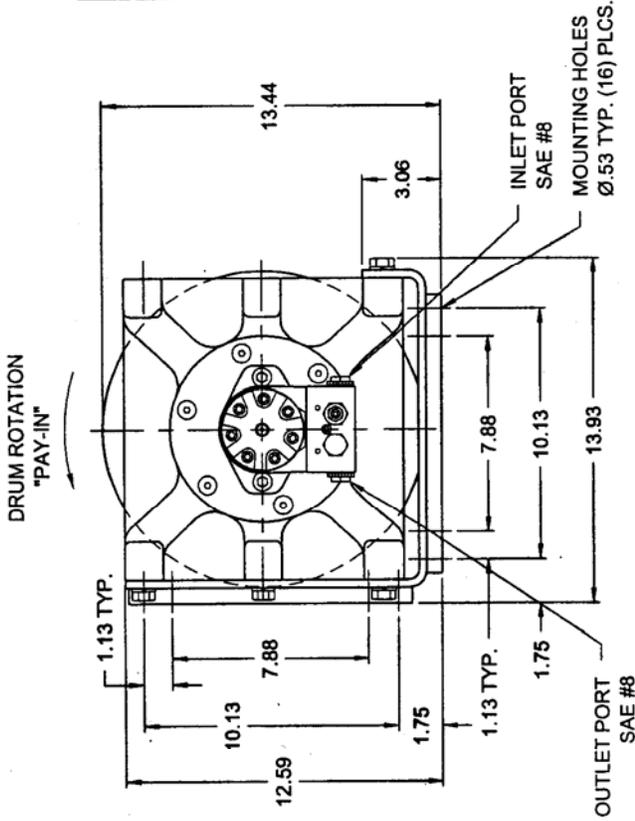
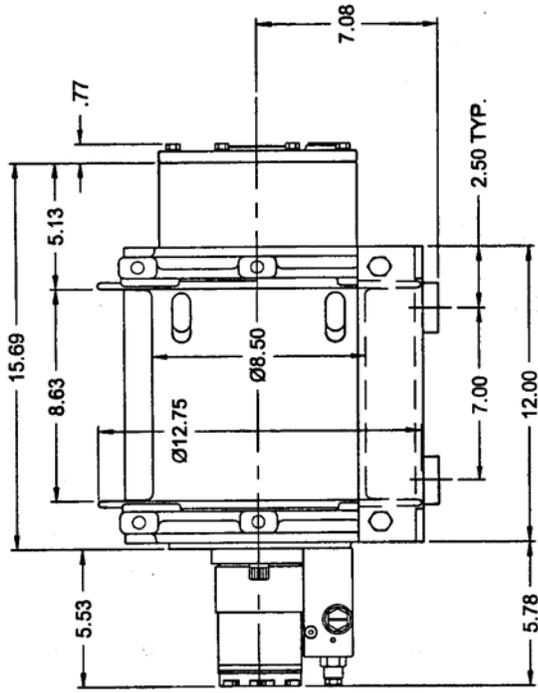

PERFORMANCE DATA

Layer	Line Pull (lbs.)	Line Speed (fpm)	Drum Capacity (ft.)
1	8550	45	41
2	7700	50	86
3	7000	55	135
4	6410	60	190

Performance is based on 12 gpm @ 2650 psi with Ø1/2 wire rope
 Rated line pulls shown are for the winch only.
 Consult the wire rope manufacturer for wire rope ratings.

AJ8CAS1L6A-002

12-28-05

This drawing is the property of
 dp Mfg. Inc. Reproduction or the
 divulging of data hereon is not
 permitted without specific approval
 of dp Mfg. Inc.



dp Manufacturing, Inc.
 Tulsa, Ok. USA
 Ph. (918) 250-2450
 Fax. (918) 250-0690

use of... id proc... reserve... to view... press... police

CAUTION:

IF THE WIRE ROPE IS NOT INSTALLED FOR THE CORRECT DRUM ROTATION, THE WINCH BRAKE VALVE WILL NOT HOLD THE LOAD.

INSERT WIRE ROPE END INTO POCKET OPENING AND THROUGH WEDGE POCKET.

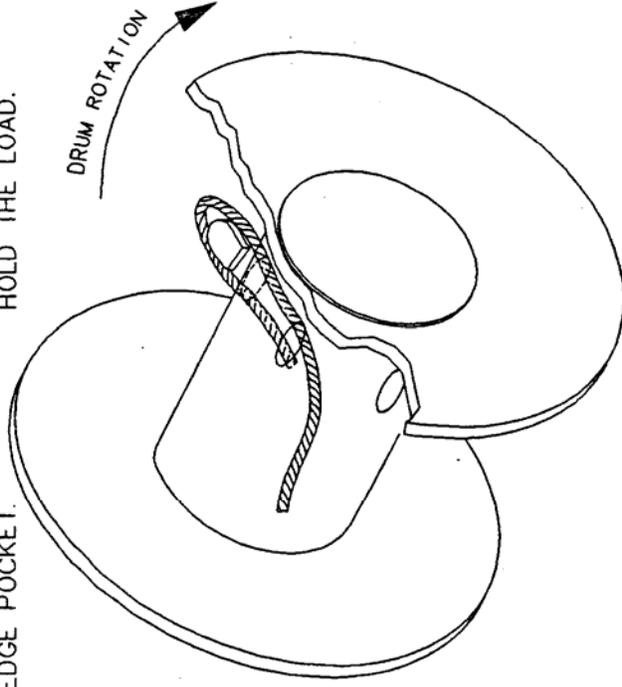

WIRE ROPE INSTALLATION

COMMERCIAL INTERTECH MOTOR

TO REVERSE WIRE ROPE PULL IN DIRECTION

METHOD 1

REMOVE THE COUNTERBALANCE VALVE AND OUTLET FLANGE.
REMOVE THE MOTOR MOUNTING BOLTS AND ROTATE THE MOTOR 180°.
REASSEMBLE MOTOR, COUNTERBALANCE VALVE, AND OUTLET FLANGE.

METHOD 2

SWITCH POSITIONS OF COUNTERBALANCE VALVE AND OUTLET FLANGE.
NOTE: HOSES GOING TO BRAKE HOUSING MAY NEED TO BE LONGER.

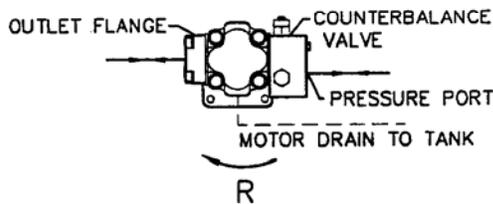
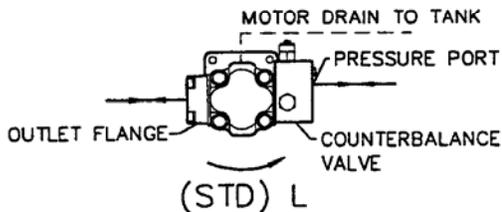

CHAR-LYNN MOTORS

(STD) L

- L PRESSURE TO V1 ROTATES WINCH DRUM CLOCKWISE WHEN VIEWED FROM MOTOR END.
- R PRESSURE TO V2 ROTATES WINCH DRUM COUNTER CLOCKWISE WHEN VIEWED FROM MOTOR END.

TO REVERSE WIRE ROPE PULL DIRECTION,
SWITCH POSITIONS OF CARTRIDGE AND PLUG.

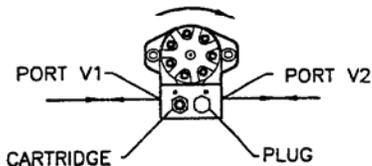

(STD) L

- L PRESSURE TO V1 ROTATES WINCH DRUM COUNTER CLOCKWISE WHEN VIEWED FROM MOTOR END.
- R PRESSURE TO V2 ROTATES WINCH DRUM CLOCKWISE WHEN VIEWED FROM MOTOR END.

TO REVERSE WIRE ROPE PULL DIRECTION,
SWITCH POSITIONS OF CARTRIDGE AND PLUG.

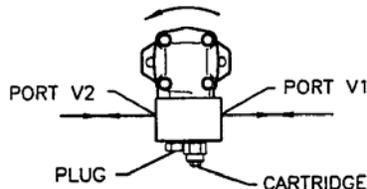

TYPICAL WINCH HYDRAULIC SYSTEM

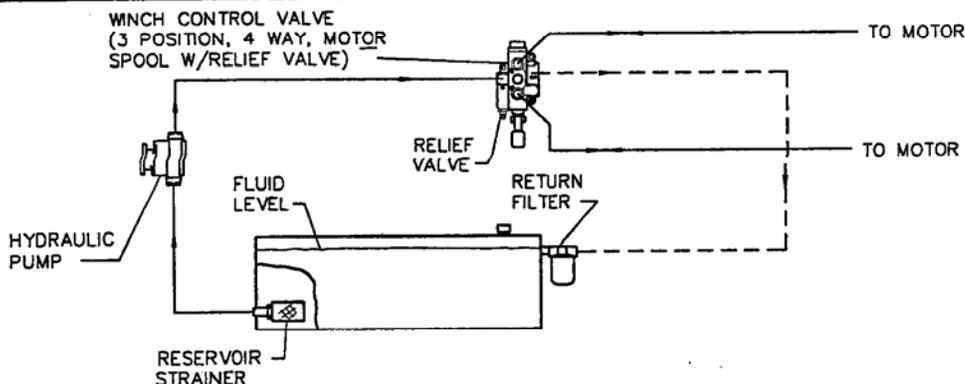

ALL UTILITY UNITS ARE BI-DIRECTIONAL WITHOUT MANIPULATION OF CARTRIDGE, AND OR PLUG LOCATIONS.

NOTE: IF TENSIONER AND, OR FAIRLEAD OPTIONS EXIST, THEN REVERSAL OF THEIR POSITION IN RELATION TO WINCH MUST TAKE PLACE BEFORE REVERSAL OF WIRE ROPE PULL DIRECTION CAN OCCUR.

SERVICE INSTRUCTIONS DP BRAKE

GENERAL:

The winch is fully hydraulic with a multi disc wet brake. The brake is spring applied and hydraulically released, and will automatically set any time the winch control valve is in neutral or in case of power failure. When the hydraulic pressure is less than 270 psi, the brake will set. Hydraulic power must be restored before brake will release. Maximum brake torque is achieved at 0 psi.

CAUTION: (These winches are not to be used for moving or lifting people.)

DISASSEMBLY OF BRAKE

(REFER TO MOTOR END INSTALLATION DRAWING 1.10407)

1. Disconnect motor (item 17) from motor adapter (item 2) by removing two capscrews (item 21), lock washers (item 22), and capscrew (item 20). Allow oil to drain.
2. Remove motor adapter (item 2) by removing six flat socket head screws (item 15). Do not lose o-rings (item 13).
3. In removing motor adapter (item 2), dowel pins (item 5), & piston (item 3) should follow.
4. Remove friction plates (item 6), stationary plates (item 7).
5. Remove piston (item 3) and motor adapter (item 2), being careful not to damage o-rings on piston.
6. Remove o-rings and back-up rings (item 9, 10, 11, 12, 27, 28 & 29,) from piston and motor adapter (item 2).
7. Finally, remove springs (item 8) from end support (item 1).

ASSEMBLY OF BRAKE

1. Lubricate all o-rings and backup rings with clean hydraulic oil used in the system.
2. Clean all parts thoroughly and visually examine for cuts, dents or other damage before assembly. Repair or replace parts with such defects.
3. Insert three springs (item 8) into holes in end support (item 1).
4. Assemble o-rings and back up rings (item 9, 10, 11, 12, 27, 28 & 29,) on piston and motor adapter (item 2). Position backup rings as illustrated.
5. Insert piston (item 3), (and this subassembly into support (item 1), be careful of o'rings
6. Insert a friction plate (item 6) alternating with a stationary plate (item 7) into piston (item 2) until all plates are in place in sequence illustrated. Insert dowel pins (item 5) into piston.
7. Next, slide the motor adapter (item 2) into place over the dowel pins (item 5) and tap down until firm. Install flat socket head capscrews (item 15). Proceed to tighten evenly against springs until motor adapter face (item 2) is in full contact and capscrews are torqued to 25 ft. lbs.
8. The motor (item 17), and o-ring (item 16) can now be reinstalled on motor adapter (item 2). Confirm seating of o-rings (item 13), as seen on motor end, 'exploded view' then insert motor adapter (item 2) and secure with capscrews (item 21), lock washers (item 22).
9. Refill winch with oil through gear end cover fill port (refer to gear end cover installation drawing). Allow time for oil to travel through brake end.

BRAKE TROUBLE SHOOTING

1. Brake will not release:
 - (a) Insufficient system pressure to brake.
 - (b) Damaged o-rings or back up ring seals (item 9, 10, 11, 12, 27, 28, & 29).
 - (c) Damaged piston (item 3) or motor adapter (item 2).
 - (d) Damaged seal surfaces within motor adapter (item 2).
 - (e) Friction or drive plates (items 6 or 7) warped or heat damaged.
2. Brake will not apply or applies but torque low:
 - (a) Damaged springs (item 8), either broken or heat damaged and having taken a permanent set or not placed in proper direction. (b) Friction plates (item 6) worn out.
3. Oil leaks externally from brake: (a) Damaged o-ring on motor adapter (item 12).

ITEMS 26 & 27
TO BE PLACED
INSIDE MOTOR
ADAPTER ITEM 2

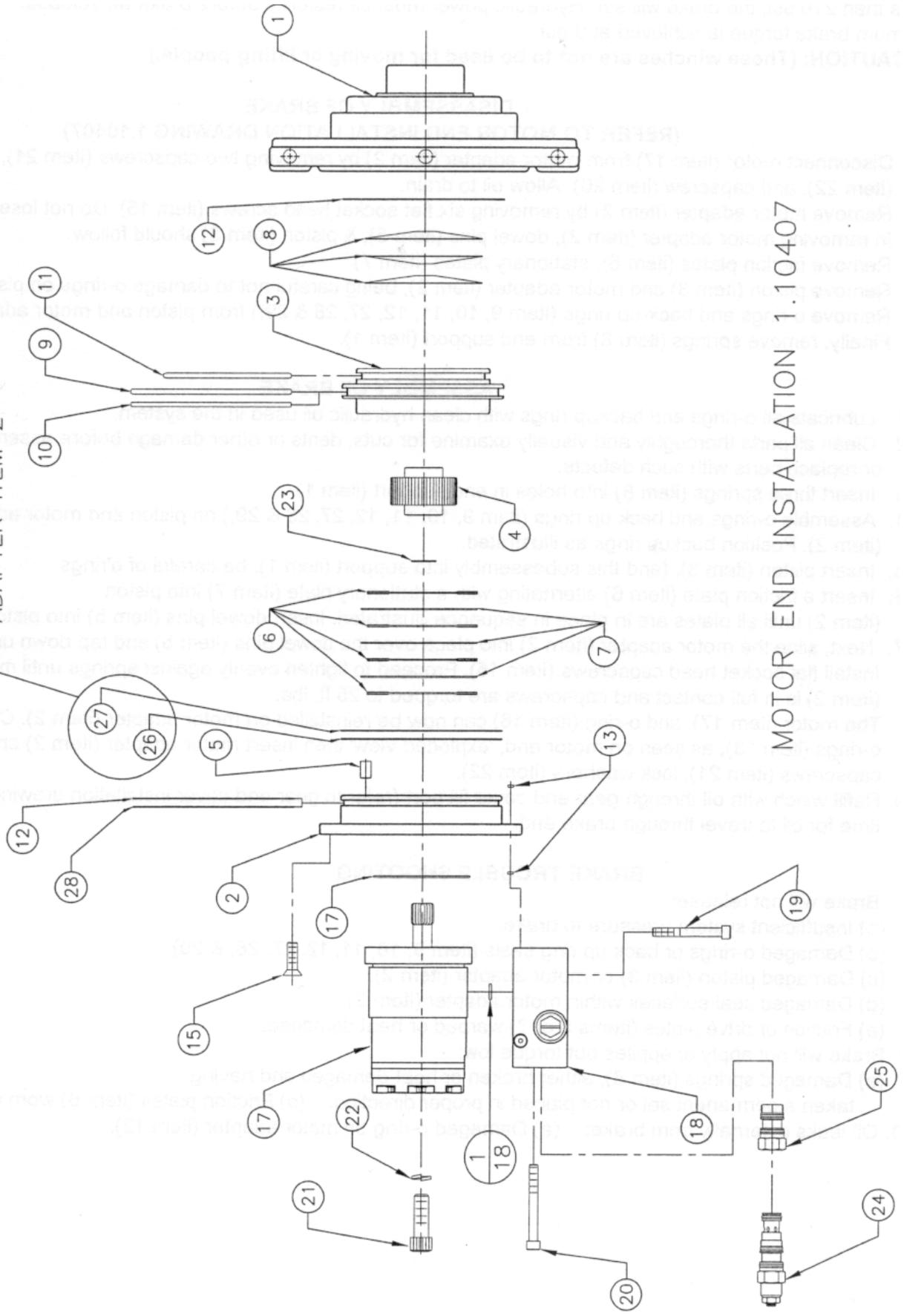

MOTOR END INSTALLATION 1.10407

1.10407 PARTS LIST
MOTOR END INSTALLATION

<u>LOC.</u>	<u>PART NO.</u>	<u>DESCRIPTION</u>	<u>QTY.</u>
1	13606	SUPPORT – MOTOR END	1
2	13602	ADAPTER – MOTOR	1
3	13603	PISTON – BRAKE	1
4	13934	SHAFT – BRAKE	1
5	3437	PIN – DOWEL – 3/8 x 5/8	3
6	13934	PLATE – FRICTION – BRAKE	4
7	13034	PLATE – STATIONARY – BRAKE	3
8	3607	SPRING – BELLEVILLE 4 x 2 x .12 x .14	3
9	9851	O-RING – 5 3/8 I.D. x 3/16 SECTION	1
10	9852	RING – BACK-UP – 5.278 I.D. x .076	1
11	9709	O-RING – 4 3/8 I.D. x 3/16 SECTION	1
12	9843	O-RING – 5 1/2 I.D. x 5 3/4 O.D. x 1/8 SECTION	1
13	9612	O-RING – 1/8 I.D. x .103 SECTION	2
14	3440*	PLUG – EXPANDER	2
15	4344-8	CAP SCREW –FLAT – SOCKET HEAD – 3/8 – 16NC x 7/8 – GRADE 8	6
16	9637	O-RING – 3 1/4 I.D. x 3/32	1
17	73215	MOTOR – HYDRAULIC	1
18	13936	VALVE – ASSEMBLY – COUNTERBALANCE	1
1.	9730	O-RING – 15/32 I.D. x 3/32 SECTION	2
19	1167	CAP SCREW SOCKET HEAD – 5/16 – 18 x 2	4
20	4076	CAP SCREW – SOCKET HEAD – 1/4 – 20UNC x 4 1/2	1
21	1454	CAP SCREW – SOCKET HEAD – 1/2 – 13NC x 1 1/4	2
22	1144	WASHER – LOCK – 1/2 – HI COLLAR	2
23	3460	RING – RETAINER – 3/4 x .035 THICK	1
24	70040	CARTRIDGE	1
25	70042	PLUG – SUN	1
26	9600	O-RING – 4 3/4 I.D. x 5 1/8 O.D. x 3/16	1
27	9711	RING – BACKUP– 4 3/4 I.D. x .183	1
28	9846	RING – BACKUP – 5 1/2 I.D.	1

* NOT SHOWN ON EXPLODED DRAWING.

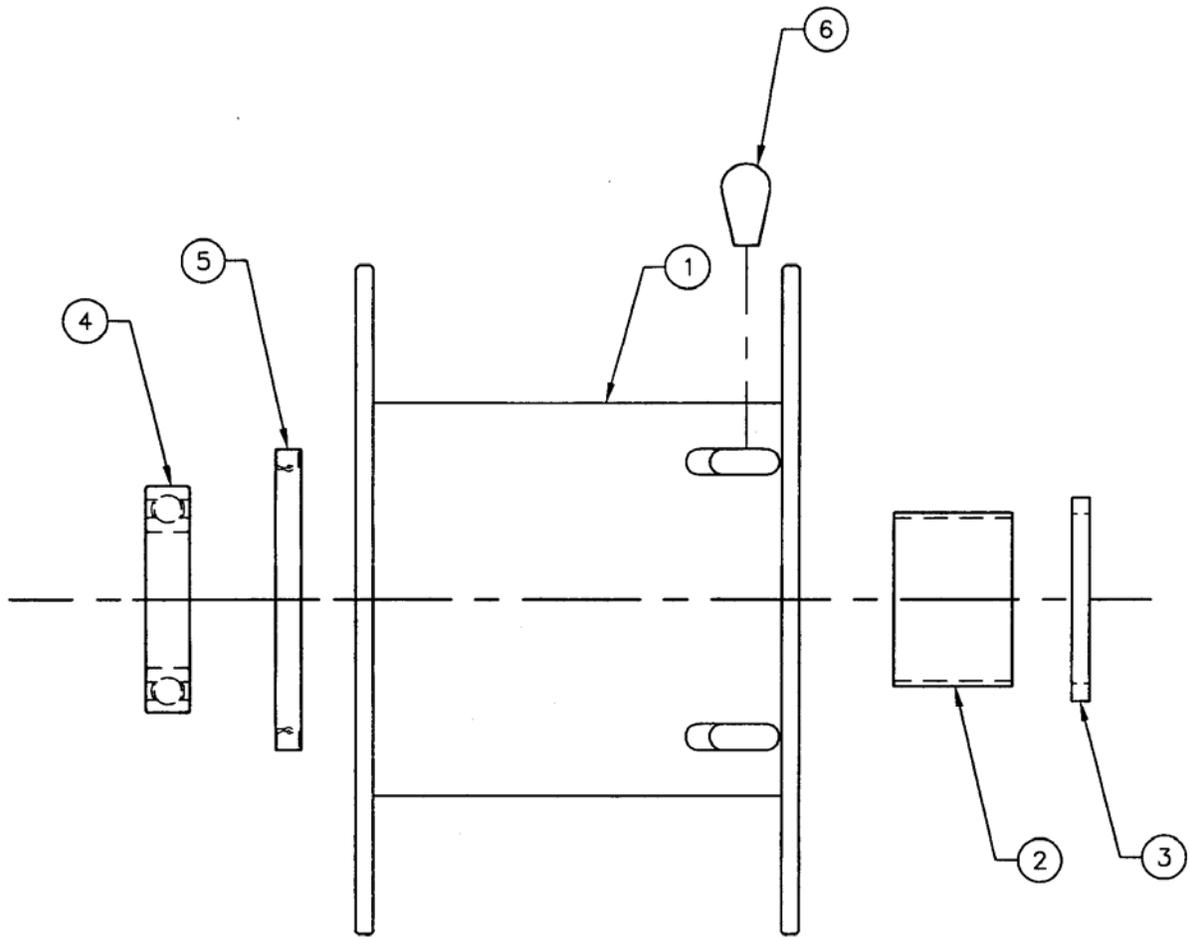

DRUM INSTALLATION
1.20149

1.20149 PARTS LIST
CABLE DRUM INSTALLATION

<u>LOC.</u>	<u>PART NO.</u>	<u>DESCRIPTION</u>	<u>QTY.</u>
1	13604	DRUM – 8 ½ BD x 12 ¾ FD x 8 5/8 WBF	1
2	11947	BEARING – BRONZE – 3 ½ I.D. x 3 ¾	1
3	9929	SEAL – SHAFT – 3 5/8 I.D. x .375	1
4	81483	BEARING – BALL – 4.9 O.D. x 2.76 I.D.	1
5	9708	SEAL – 5.5 I.D. x 6.5 O.D.	1
6	11392	WEDGE – CABLE – ½	1

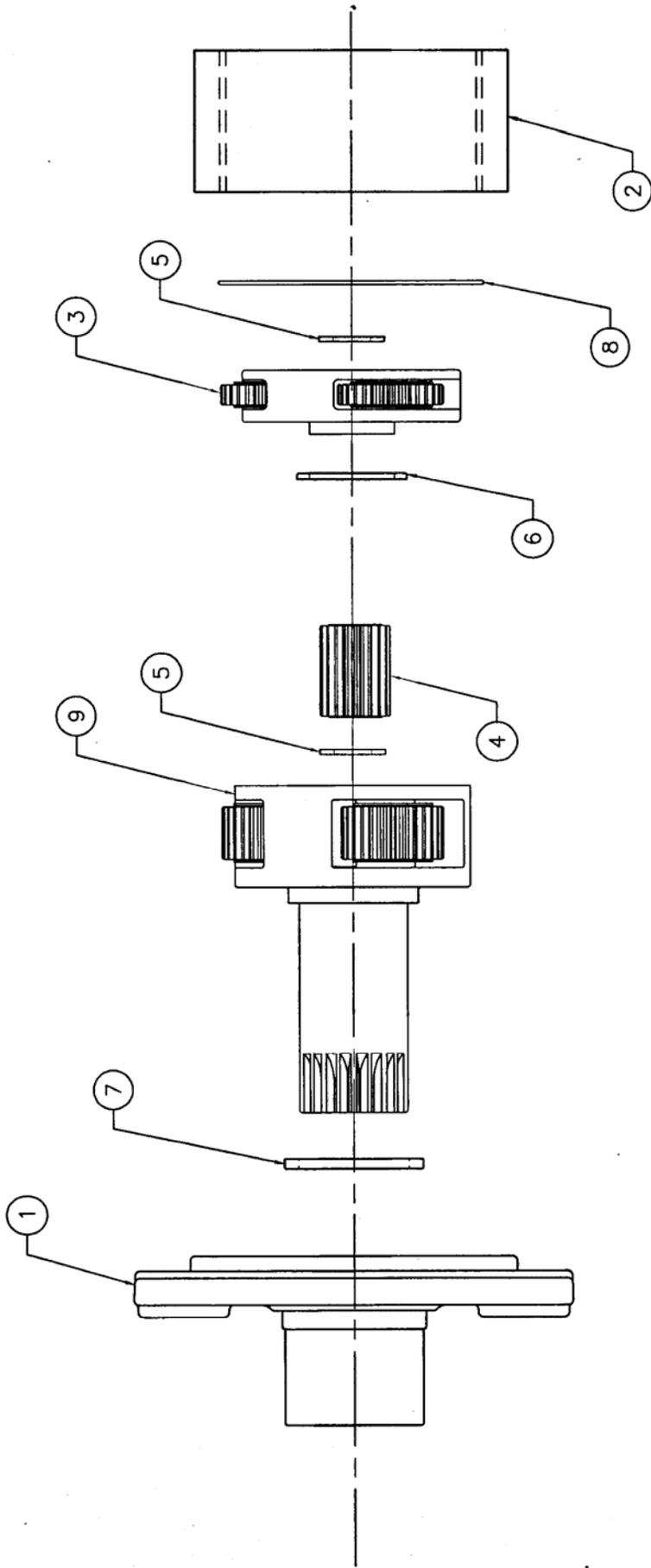

GEAR END INSTALLATION
1.30133

1.30133 PARTS LIST
GEAR END INSTALLATION

<u>LOC.</u>	<u>PART NO.</u>	<u>DESCRIPTION</u>	<u>QTY.</u>
1	13605	SUPPORT – END – GEAR	1
2	81107	GEAR – RING	1
3	12447	CARRIER – PRIMARY	1
4	13380	GEAR – SUN	1
5	13385	WASHER – THRUST – 1.625 O.D. x .937 I.D. x .125 THICK	2
6	12083	WASHER – THRUST – NYLON – J	1
7	13164	WASHER – THRUST – NYLON – 3 ½ O.D. x 3/16	1
8	9897	O–RING – 6 ½ I.D. x 3/32 SECTION	1
9	13379	ASSEMBLY – CARRIER – SECONDARY	1

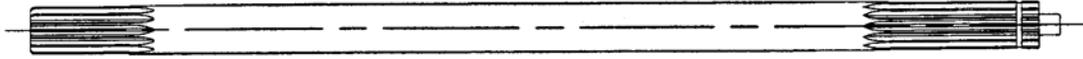

INPUT SHAFT INSTALLATION
1.40287

1.40287 PARTS LIST
INPUT SHAFT INSTALLATION

<u>LOC.</u>	<u>PART NO.</u>	<u>DESCRIPTION</u>	<u>QTY.</u>
1	14411	SHAFT - INPUT	1

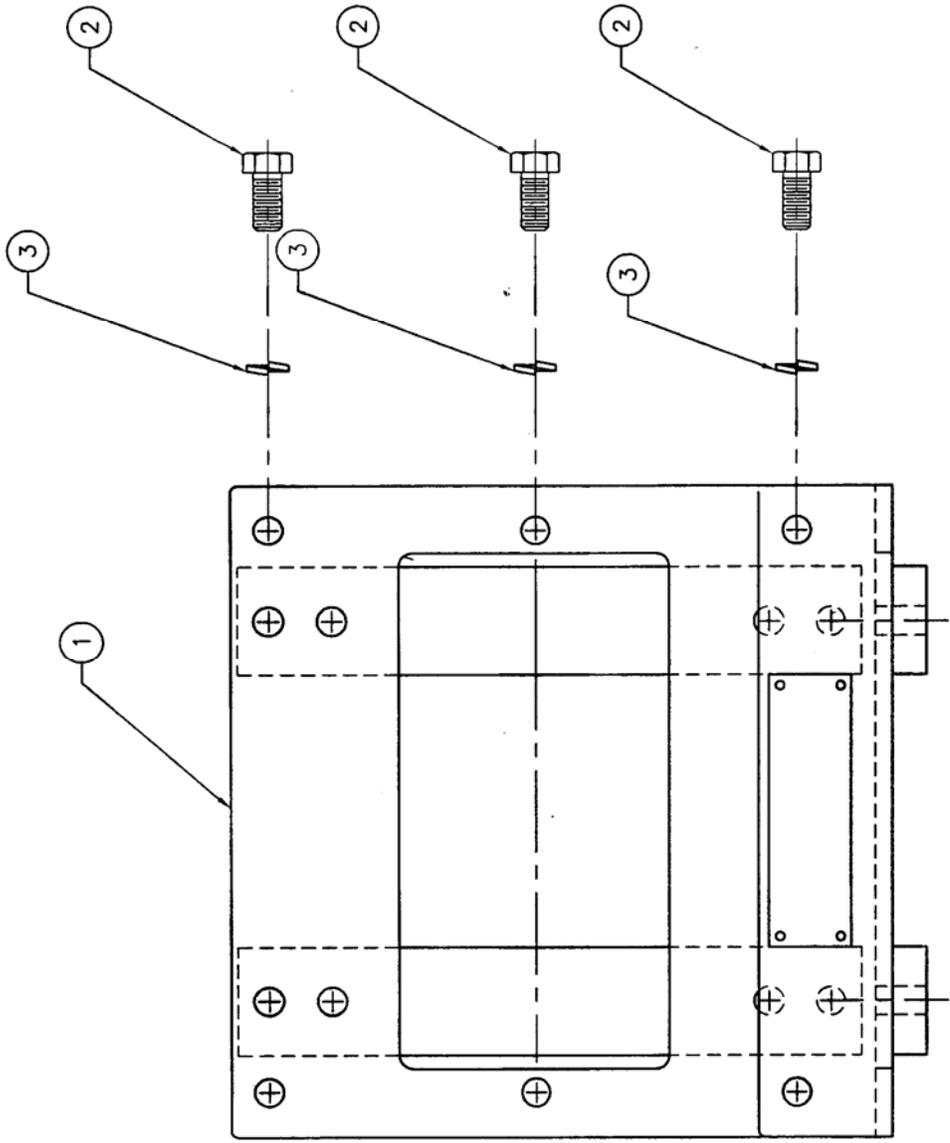

BASE MOUNT INSTALLATION 1.50236

1.50236 PARTS LIST
BASE MOUNT INSTALLATION

<u>LOC.</u>	<u>PART NO.</u>	<u>DESCRIPTION</u>	<u>QTY.</u>
1	13599	BASE - MOUNTING	1
2	1401	CAP SCREW - HEX HEAD - 1/2 - 13NC x 1	8
3	1495	WASHER - LOCK - 1/2	8
4	12113*	PLATE - ID - WINCH	1
5	1165*	RIVET - TYPE - U	4

* NOT SHOWN ON EXPLODED DRAWING.

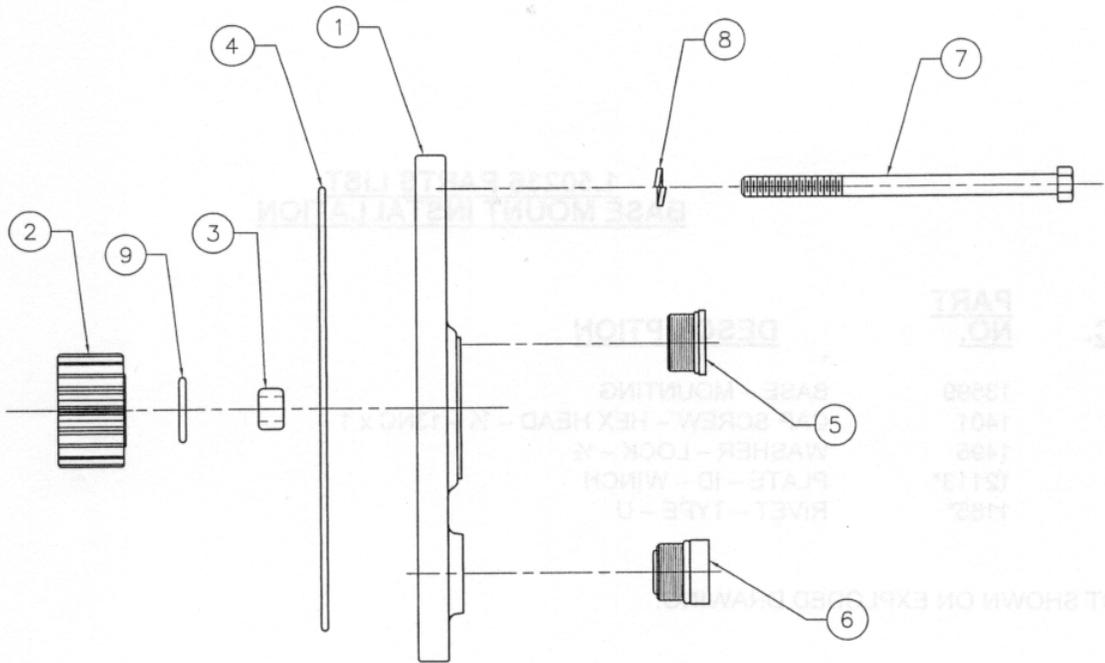

GEAR END COVER INSTALLATION
1.60112

1.60112 PARTS LIST
GEAR END COVER INSTALLATION

<u>LOC.</u>	<u>PART NO.</u>	<u>DESCRIPTION</u>	<u>QTY.</u>
1	13369	COVER	1
2	13405	GEAR – SUN	1
3	81612	BUSHING – BRONZE – 5/8 O.D. x 3/8" I.D. x 3/8	1
4	9897	O-RING – 6 1/2 I.D. x 3/32 SECTION	1
5	76344	PLUG – O-RING – BOSS – #10 – SOCKET HEAD – 7/8 – 14	1
6	76343	PLUG – SOCKET HEAD – O-RING – BOSS – #10	1
7	3004	CAP SCREW – HEX HEAD – 5/16" – 18 x 4 3/4 – GRADE 8	8
8	1168	WASHER – LOCK – 5/16	8
9	3321	RING – RETAINER – 7/8 x .08 THICK – ROUND SECTION	1

Calculated Generic Bolt Installation Torques

Nominal Diameter/ Thread Pitch	Grade (5) T		Grade (8) T	
	lb*Ft	(lb*in)	lb*Ft	(lb*in)
1/4-20	6.3	(76)	8.9	(107)
5/16-18	13	(156)	18.5	(221)
3/8-16	23		33	
7/16-14	37		53	
1/2-13	57		80	
5/8-11	113		159	
3/4-10	200		282	
7/8-9	322		454	
1-8	483		682	
1 1/8-7	596		966	

This table is used for applications without external loads. Reference EN11000.

This standard defines generic torque values for installing threaded fasteners used in the manufacture of DP products. This document is not intended to over-ride or otherwise change specific torque values defined individually on other DP documents.

GENERAL INFORMATION

MISCELLANEOUS LUBRICATION POINTS

dp fairlead rollers require lubrication by a medium heavy oil on a weekly basis. Fairlead rollers are supplied with oil impregnated bronze bearing and require a few drops of medium heavy oil at each bearing location.

Manual kick out levers should be cleaned and lubricated with a coat of light oil on the shaft and detent mechanism (avoid excessive oil build up, which will attract dust).

PNEUMATIC SYSTEM

This product uses air pressure to power the drum disengagement. This component requires clean dry air for trouble free service. A typical pneumatic system should have an FDL (filter, dryer, lubricator) and a pressure regulator. More than (1) pressure regulator may be required, depending on the pressure requirements of the different components. It is important to keep moisture from entering the winch. Moisture could cause corrosion. If temperatures fall below 32°F, moisture could freeze and render the component inoperable. *See the dimensional drawing for the pressure requirements.*

EXTENDED STORAGE PROCEDURES

If you plan to store your **dp** product for more than 90 days some extra precautions are required to insure your product will be ready to perform when put back into service.

- Wash and dry the exterior of the winch.
- Service the wire rope as recommended by the wire rope manufacturer.
- The winch should be filled with the appropriate corrosion-inhibiting lubricant and operated for 5 minutes in both directions to distribute the lubricant. The winch should then be filled to the highest possible level, I.E. vent high (this will insure the maximum coverage of internal components). *Note: drain oil to normal operation level before returning to service.*
- The internal components of the pneumatic system should be coated with a corrosion-inhibiting lubricant. If a pneumatic lubrication system is not installed, this can be accomplished by spraying an aerosol lubricant into the ports of the components and shifting several times to distribute the lubricant evenly.
- All ports should be plugged (i.e. motor inlet/outlet ports, drum disengagement)
- Lubricate all external components
 - Fairlead rollers
 - Pivot points of cable hold down
 - Manual drum disengagement handle

HYDRAULIC SYSTEM

FLUID SPECIFICATIONS

When choosing a fluid, it is important to consider the start-up and operating temperatures of the hydraulic system. Generally the fluid is thick when started and with movement it warms and thins out. Premium grade petroleum based hydraulic fluids will provide the best performance. They contain anti-wear agents, rust/oxidation inhibitors, and anti-foaming agents. **dp** recommends an oil viscosity of 20-43 cSt and a temperature range of 100-140°F. The oil viscosity should never fall below 13 cSt or the temperature rise above 180°F. Oil viscosity greater than 43 cSt is not normally detrimental to the motors used on **dp** products, except 2 speed and variable displacement motors. *Consult your local hydraulic fluid distributor for assistance in selecting a fluid that would best suit your climate and application.*

FLUID / SYSTEM MAINTENANCE

Maintaining correct fluid viscosity and cleanliness level is essential for all hydraulic systems. **dp** products are used in a wide variety of applications and it is impossible to publish a fluid maintenance schedule that would cover every situation. **dp** recommends that the minimum hydraulic fluid cleanliness be maintained at an ISO Cleanliness Code 18/13 rating. *Your hydraulic system designer can recommend an adequate filtration system and maintenance schedule to achieve this rating.*

WINCH LUBRICATION

LUBRICANT SPECIFICATIONS

Gear lubrication is an important component in insuring the long life of your winch. The type of lubricant will have a great influence. Generally a gear lubricant should have a viscosity of 100 to 250 cSt at the expected ambient operating temperature. For operation in lower temperature ranges, it is imperative that the pour point of the lubricant be at least 10° below the lowest ambient temperature. The oil you select should meet GL5 performance standards for high pressure, possess rust/oxidation inhibitors, and low foaming properties. Many lubricants available under a variety of trade names meet these requirements. Unless otherwise requested, the gear oil your winch was shipped with is *GL5 80W90*. *Consult your local lubricant distributor on the selection that best fits your climate and application.*

GENERAL LUBRICANTS

For Reference Only

Temperature (°F)	Type of oil	Viscosity (cSt) At 40°/100°C
10° to 120°	85W140	360/25
-25° to 40°	80W90	145/15
-50° to 30°	Synthetic ISO 32	31/6

All types of lubricant listed here conform to MIL SPEC-L-2105D.

CHANGE INTERVAL

The initial lubricant should be changed after the first 10 hours of operation. During this "breaking in" period it is normal for the lubricant to contain minuscule black & bronze particles. Subsequent changes should be scheduled every 250 hours of operation or annually.

LUBRICATION LEVEL

The oil level should be checked with the winch centerline horizontal. The winch should be filled to the bottom of the fill/level plug. If your winch has more than (1) fill/level plug, select the plug that is slightly above the centerline. *If unit is mounted in a non-standard orientation, consult dp Service Department for lubrication level information.*

GREASE

If the winch comes with a fairlead that has grease fittings on the rollers, the grease used conforms to MIL-G-10924 and should be used in the temp range of -50° F to 120° F.

1. Oil Check and Fill
 - a. Remove oil fill plug.
 - b. Oil level should be visible. If overfull and thin it may indicate hydraulic oil leakage through the brake. correct by draining and refilling before operating winch. If this condition continues winch should be checked for seal failure. See "Trouble Shooting Information.
 - c. Add specified gear lubrication oil as required to bring to proper level.
 - d. If winch lubrication oil consistently checks low, inspect unit for leaking seals or gaskets.
2. Oil Drain and Replacement
 - a. Remove oil drain & fill plug.
 - b. Drain oil.
 - c. Clean drain plug and replace. Fill with oil to proper level.
 - d. Oil should be changed after the first 6 weeks of operation. Change should then be on an annual basis.
3. **CAUTION:** Winch lubrication oil is not hydraulic oil.

Note: dp Manufacturing, Inc. takes no responsibility for the subsequent performance of hydraulic or mechanical components if oil, grease or hydraulic fluid possessing properties other than what dp Manufacturing, Inc. recommends is used.

REPAIR & REPLACEMENT PARTS ORDERING INFORMATION

*To insure satisfactory product performance after repairs, always use genuine **dp** Manufacturing replacement parts.*

MODEL IDENTIFICATION

Always furnish the **dp** Model Number and Serial Number when ordering parts. This information is found on the product nameplate and/or stamped on top of the motor end support.

PART NUMBER AND DESCRIPTION

In addition to the serial number, always give the part number and description of each part ordered. If there is any doubt as to the correct part number and description, furnish a dimensional sketch or return the part to be replaced.

Your cooperation in furnishing as much information as possible will assist us in filling your orders correctly in the shortest possible time.

FACTORY RETURNS / SERVICE

Advanced authorization is required prior to the return of any items to **dp** Manufacturing, Inc. Contact the **dp** Service Department for a Return Goods Authorization (RGA) number. Shipment to and from **dp** Manufacturing, Inc. shall be at the customers expense.

Remit all correspondence concerning parts, service, and returned goods authorization to:

dp Manufacturing, Inc.
PO Box 471710
5647 South 122nd East Ave
Tulsa, Oklahoma 74146

Phone (918) 250-2450
Fax (918) 250-0690
E-Mail service@dpwinch.com

Notes:

DP Winch Limited Warranty

Effective 1/1/2005

SUPERSEDES ALL PRIOR WARRANTIES

Seller warrants that each article sold under this order shall at the time of shipment (i) conform to applicable specifications, and (ii) be free from defects in material and workmanship during normal and ordinary use and service (the "Warranty").

Buyer's exclusive remedy and Seller's sole obligation under this Warranty shall be, at Seller's option, to repair or replace any article or part thereof which has proven to be defective, or to refund the purchase price of such article or part thereof.

This Warranty shall expire one (1) year from the date the article is first shipped by Seller. Notice of claimed breach of this Warranty must be given by Buyer to Seller within the applicable period. Such notice shall include an explanation of the claimed warranty defect and proof of date of purchase of the article or part thereof for which warranty coverage is sought. No allowances shall be made by Seller for any transportation, labor charges, parts, "in and out" costs, adjustments or repairs, or any other work, unless such items are authorized in writing and in advance by Seller. Nor shall Seller have any obligation to repair or replace items which by their nature are expendable.

If an article is claimed to be defective in material or workmanship, or not to conform to the applicable specifications, Seller will either examine the article at Buyer's site or issue shipping instructions for return to Seller. This Warranty shall not extend to any articles or parts thereof which have been installed, used, or serviced otherwise than in conformity with Seller's applicable specifications, manuals, bulletins, or instructions, or which shall have been subjected to improper installation, operation, or usage, misapplication, neglect, overloading, or employment for other than normal and ordinary use and service.

This Warranty shall not apply to any articles or parts thereof furnished by Seller to Buyer's specifications and/or furnished by Buyer or acquired from others at Buyer's request.

SELLER MAKES NO EXPRESS WARRANTIES AND NO IMPLIED WARRANTIES OF ANY KIND, OTHER THAN THE WARRANTY EXPRESSLY SET FORTH ABOVE. SUCH WARRANTY IS EXCLUSIVE AND IS MADE AND ACCEPTED IN LIEU OF ANY AND ALL OTHER WARRANTIES, EXPRESS OR IMPLIED, INCLUDING WITHOUT LIMITATION THE IMPLIED WARRANTIES OF MERCHANTABILITY AND FITNESS FOR A PARTICULAR PURPOSE.

The remedies for this Warranty shall be only those expressly set forth above, to the exclusion of any and all other remedies of whatsoever kind. The limited remedies set forth above shall be deemed exclusive, even though they may fail their essential purpose. No agreement varying or extending the foregoing Warranty, remedies, exclusions, or limitations shall be effective unless in a writing signed by an executive officer of Seller and Buyer. This Warranty is non-transferable.

Under no circumstances shall Seller be liable (i) for any damage or loss to any property other than the warranted article or part thereof, or (ii) for any special, indirect, incidental, or consequential damage or loss, even though such expenses, damages, or losses may be foreseeable.

The foregoing limitations on Seller's liability in the event of breach of warranty shall also be the absolute limit of Seller's liability in the event of Seller's negligence in manufacture, installation, or otherwise, with regard to the articles covered by this Warranty, and at the expiration of the Warranty period as above stated, all such liabilities shall terminate.