

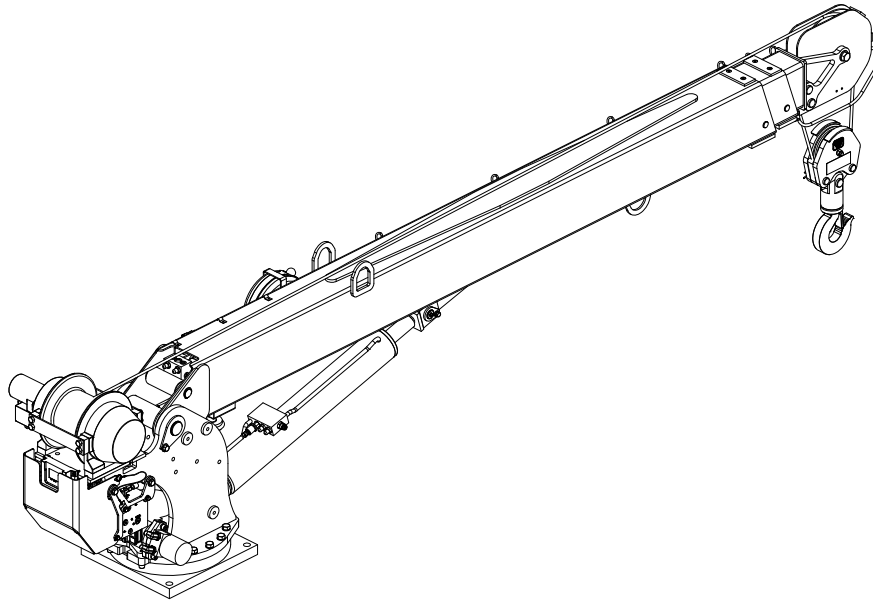

10006 NEXSTAR OWNERS MANUAL

Manual No. 460178010



Serial No. _____

Mailing Address:
P.O. Box 580697
Tulsa, OK 74158-0697
Physical Address:
4707 N. Mingo Rd.
Tulsa, OK 74117-5904

Phone 1-800-777-2760
Fax (918) 269-6688
<http://www.autocrane.com>



Auto Crane Warranty Registration

Fax Transmission

To: Warranty Department Fax: (918) 834-5979
 From: _____ Date: _____
 Re: Product Registration Pages: _____

End User Information: (Required for Warranty Activation)

Name: _____ Phone: _____
 Address: _____
 City: _____ State: _____ Zip: _____
 Contact: _____ E-mail Address: _____

Distributor Information: (Required for Warranty Activation)

Name: _____
 Address: _____
 City: _____ State: _____ Zip: _____
 Contact: _____ E-mail Address: _____

Product Information: (Required for Warranty Activation)

Model No.: _____ Serial No.: _____
 Date Product Delivered: _____ Date Processed: * _____
 VIN # _____ * For Auto Crane use only

ONE REGISTRATION FORM PER UNIT (CRANE OR BODY)

Registration form must be mailed or faxed within 15 days of customer installation.

Mail to:
 Warranty Department
 Auto Crane Company
 P.O. Box 581510
 Tulsa, OK 74158-0697

10006H

OWNER'S MANUAL REVISION RECORD

Revision Date	Section(s) Or Page(s)	Description of Change
6/17/10	4-9,5-6,6-1,6-3, 7-1,7-2	Changed light on crane. Revised artwork and BOM. Revised flow to 15 to 19
11/19/10	6-3.0	Corrected 36 gallon reservoir to 23 gallon reservoir
11/24/10	1-3.0, 6-3.0	Removed Hydraulic Requirements from General Specification Sheet, Added Note
12/22/2010	8-4.0, 8-6.0	Changed P/N 366823907 to 366823914, 366823908 to 366823913

Notes:

1. The information contained in this manual is in effect at the time of this printing. It does not cover all instructions, configurations, accessories, etc. If you require additional information, please contact **Auto Crane Company** at **1-800-777-2760**.
2. **Auto Crane Company** reserves the right to update this material without notice or obligation.

WARNINGS

WARNING! Federal law (49 cfr part 571) requires that the Final Stage Manufacturer of a vehicle certify that the vehicle complies with all applicable federal regulations. Any modifications performed on the vehicle prior to the final state are also considered intermediate stage manufacturing and must be certified as to compliance. The installer of this crane and body is considered one of the manufacturers of the vehicle. As such a manufacturer, the installer is responsible for compliance with all applicable federal and state regulations, and is required to certify that the vehicle is in compliance.

WARNING! It is the further responsibility of the installer to comply with the OSHA Truck Crane Stability Requirements as specified by 29 CFR part 1910.180 (C) (1).

WARNING! NEVER OPERATE THE CRANE NEAR ELECTRICAL POWER LINES!

Death or serious injury will result from boom, line, or load contacting electric lines. Do not use crane within 10 feet (3.05m) of electric power lines carrying up to 50,000 volts. One-foot additional clearance is required for every additional 30,000 volts or less. **SEE DANGER DECAL (P/N 040529)** in this Owner's Manual.

WARNING! NEVER.....

- **EXCEED** load chart capacities (centerline of rotation to hoist hook).
- Un-reel last 5 wraps of cable from drum!
- Wrap cable around load!
- Attempt to lift or drag a load from the side! The boom can fail far below its rated capacity.
- Weld, modify, or use unauthorized components on any Auto Crane unit! This will void any warranty or liability. Also failure of the crane may result.
- Place a chain link on the tip of the hook and try to lift a load!
- Use a sling bar or anything larger than the hook throat that could prevent the hook latch from closing, thus negating the safety feature!
- Hold on any pendant Select Switch that will cause unsafe operating conditions!

WARNING! In using a hook with latch, **ALWAYS** make sure that the hook throat is closed before lifting a load! Proper attention and common sense applied to the use of the hoist hook and various slings will prevent possible damage to material being hoisted and may prevent injury to personnel.

WARNING! Failure to correctly plumb and wire crane can cause inadvertent operation and damage to crane and/or personnel!

WARNING! Auto Crane Company remote controlled cranes are not designed or intended for use for any applications involving the lifting or moving of personnel.

WARNING! ALWAYS operate the crane in compliance with the load capacity chart. **DO NOT USE** the overload shutdown device to determine maximum rated loads, if the crane is equipped with this type of device.

READ THIS PAGE

10006H

TABLE OF CONTENTS

INTRODUCTION	1-1.0
GENERAL SPECIFICATIONS	1-3.0
SAFETY TIPS AND PRECAUTIONS	2-1.0
OPERATING PRACTICES & WARNINGS	2-3.0
QUALIFICATIONS FOR OPERATORS	2-4.0
OPERATION OF UNIT / OUTRIGGERS	3-1.0
CRANE OPERATION	3-2.0
INSPECTION	4-1.0
TESTING	4-3.0
MAINTENANCE	4-4.0
BATTERIES	4-6.0
LUBRICATION AND MAINTENANCE SCHEDULE	4-8.0
SAFETY DECAL SECTION	5-1.0
GENERAL DIMENSIONS	6-1.0
MOUNTING AND INSTALLATION	6-3.0
GENERAL ASSEMBLY	7-1.0
PEDESTAL ASSEMBLY	7-3.0
BOOM ASSEMBLY	7-9.0
ROTATION GEARBOX	7-11.0
HOIST ASSEMBLY	7-13.0
TRAVELING BLOCK ASSEMBLY	7-16.0
MAIN WIRING HARNESS	8-1.0
HYDRAULIC SECTION	8-3.0
COUNTERBALANCE VALVE	9-1.0
VALVE OVERRIDE OPERATION	9-2.0
TROUBLE SHOOTING CHART	9-3.0
LOAD CHART	9-8.0
WARRANTY	LAST PAGE

10006H INTRODUCTION

Auto Crane products are designed to provide many years of safe, trouble-free, dependable service when properly used and maintained.

To assist you in obtaining the best service from your crane and to avoid untimely crane and/or vehicle failure, this manual provides the following operating and service instructions. It is specifically recommended that all operating and service personnel consider this manual as mandatory material for reading and study before operating or servicing Auto Crane products. It is highly recommended that crane owners, equipment managers, and supervisors also read this manual.

Auto Crane has incorporated several safety features in the 10006H crane for your protection.

For your convenience the overall dimensions of the 10006H crane are included on the General Dimension Drawing. Rotation and turning radius are also listed on that drawing.

Remember, the crane adds weight to the vehicle. Adding weight may change the driving and riding characteristics of the vehicle unless the appropriate overload spring(s) are installed on the truck. The payload of the vehicle is reduced by the weight of the crane. The operator should exercise care when loading the vehicle. Distributing the payload on the vehicle evenly will greatly improve the driving and riding characteristics of the vehicle.

Auto Crane Company issues a limited warranty certificate with each unit sold. See last page for warranty.

The 10006H cranes are attached to your 12-volt truck electrical system through the relay provided. The 10006H is another highly efficient Auto Crane product. The use of a maintenance-free battery is not recommended on any Auto Crane product. The recommended alternator and battery that will give the longest life with the most useful duty cycle is a 60-amp

alternator with a 500 cold cranking amp battery. These specifications should be considered minimum.

It has always been Auto Crane Company policy to handle all warranty claims we receive as promptly as possible. If a warranty claim involves discrepant material or workmanship, Auto Crane will take immediate corrective action. It is understandable that Auto Crane Company cannot assume responsibility of liability when it is obvious that our products have been abused, misused, overloaded or otherwise damaged by inexperienced persons trying to operate the equipment without reading the manual.

Auto Crane will not assume responsibility or liability for any modifications or changes made to unit, or installation of component parts without authorization.

Auto Crane maintains a strong distributor network and a knowledgeable Customer Service Department. In most cases, an equipment problem is solved via phone conversation with our customer service department. The customer service department also has the ability to bring a local distributor, a regional sales manager, or a factory serviceman into the solution of an equipment problem.

If, through no fault of Auto Crane Company, it is necessary to send an experienced factory serviceman on a field service call the rates stated in the Auto Crane Distributor's Flat Rate Manual will apply.

Auto Crane Company's extensive Research and Development Program allow our customers to use the best equipment on the market. Our Engineering Staff and our knowledgeable sales people are always available to our customers in solving crane and winch-type application problems. When in doubt, call the Auto Crane factory.

Note: This manual should remain with the crane at all times.

10006H INTRODUCTION

DISTRIBUTOR ASSISTANCE:

Should you require any assistance not given in this manual, we recommend that you consult your nearest Auto Crane Distributor. Our distributors sell authorized parts and have service departments that can solve almost any needed repair. This manual does not cover all maintenance, operating, or repair instructions pertinent to all possible situations. **If you require additional information, please contact the Auto Crane Company at the following telephone number: 1-800-777-2760.** The information contained in the manual is in effect at the time of this printing. Auto Crane Company reserves the right to update this material without notice or obligation.

10006H

GENERAL SPECIFICATIONS

DIMENSIONS

Width: 24.5 in (0.62 m)
Height: 36.0 in (0.91 m)
Length: 14 ft 8 in (4.47 m)
 [Boom(s) stored]
Weight: 2,330 lbs (1057 kg)

CAPACITY

60,000 ft-lbs (8.30 ton-m)
 [ft-lbs = horizontal distance from centerline of rotation to free hanging weight (feet) x amount of weight (pounds)]

LIFTING CAPACITIES			
ft	lbs	ft	lbs
3	10,000	15	4,000
4	10,000	16	3,750
5	10,000	17	3,529
6	10,000	18	3,333
7	8,571	19	3,158
8	7,500	20	3,000
9	6,667	21	2,857
10	6,000	22	2,727
11	5,455	23	2,609
12	5,000	24	2,500
13	4,615	25	2,400
14	4,286		

REACH

Second boom will reach from 12 feet 4 inches to 20 feet 4 inches.
 Third boom will reach from 20 feet 4 inches to 25 feet 4 inches.

CABLE

120 ft (36.6 m) of 7/16 in (11.1 mm) diameter aircraft quality cable. This cable has a single line breaking strength of 20,400 lbs (9,253 kg).

CHASSIS REQUIREMENTS

26,000 lbs (11,793 kg) GVWR minimum
 900,000 in-lbs RBM

ELECTRICAL SYSTEM REQUIREMENTS

Voltage: 12 VDC
Alternator: 60 amps (minimum)
Battery: 100 minute reserve capacity (minimum)
 Maintenance type

ROTATION

370° Rotation with electric stop.

—IMPORTANT—

SAFETY TIPS AND PRECAUTIONS

1. No unqualified or unauthorized person shall be allowed to operate the crane.
2. **WARNING:** Never weld, modify, or use unauthorized components / parts on any Auto Crane unit. This will void any warranty or liability. Also, failure of the crane may result.
3. Make certain the vehicle meets minimum chassis requirements. (These requirements do not guarantee unit stability.)
4. Make certain the crane is installed per factory specifications. Contact your local distributor or the Auto Crane factory if any questions arise.
5. Visual inspections and tests should be conducted at the beginning of each shift each day to insure that the crane and all its operating systems are in good condition and working order before it is used.
6. Inspect hydraulic hoses frequently for signs of deterioration, and replace them as required.
7. If a hydraulic break occurs, leave the area of the break and do not attempt to stop the break by hand as the hydraulic oil may be hot and under high pressure which can cause serious injury. Shut the system down as soon as possible.
8. Check the hook at least every thirty days for distortions or cracks and replace it as required.
9. Oil gears as required.
10. Stop all operations when cleaning, adjusting or lubricating the machine.
11. Keep dirt and grit out of moving parts by keeping crane clean. Make sure machine is free of excess oil, grease, mud and rubbish, thus reducing accidents and fire hazards.
12. When a new cable is installed, operate first with a light load to let the cable adjust itself.
13. Locate the vehicle at the work site for the best stability possible.
14. Keep the vehicle in a level position while loading or unloading.
15. Observe operating area for obstructions and/or power lines that might be a hazard.
16. **WARNING: NEVER OPERATE THE CRANE NEAR ELECTRICAL POWER LINES.** Auto Crane Company recommends that the crane never be any closer to a power line (including telephone lines) than 10 feet at any point.
17. Allow the vehicle engine to warm up before operating crane.
18. Know the weight of your rigging and load to avoid overloading the crane.
19. Deduct the weight of the load handling equipment from the load rating to determine how much weight can be lifted.
20. All load ratings are based on crane capacity, NOT the vehicle stability. Remember in lifting a heavy load, the weight can create enough tipping moment to overturn the vehicle
21. Always comply with load chart capacities, (centerline of rotation to hook).
22. Secure all loads before lifting.
23. Always set the emergency brake before beginning operation.
24. Keep objects and personnel clear of crane path during operation.
25. Operate control levers slowly and smoothly in order to meter oil flow for safe operation. (Not applicable to electric-hydraulic cranes.)
26. Always extend the outriggers from vehicle to the ground before crane operation. Insure that they are firmly positioned on solid footings. Stand clear of outriggers while they are being extended.
27. If any outrigger, when extended, rests on a curb or other object that prevents it from extending to its maximum distance, shorten bearing or fulcrum point and reduce the maximum load accordingly.
28. When an outrigger will not reach the ground due to holes or grades, it shall be blocked up to provide level and firm support for the truck.
29. When working in soft earth, use wide pads under outrigger feet to prevent sinking.
30. Always store outriggers before transportation.

WARNING!

Auto Crane Company cranes are not designed or intended for use in lifting or moving persons. Any such use shall be considered to be improper and the seller shall not be responsible for any claims arising there from. This sale is made with the express understanding that there is no warranty that the goods shall be fit for the purpose of lifting or moving persons or other improper use and there is no implied warranty or responsibility for such purposes.

—IMPORTANT—

SAFETY TIPS AND PRECAUTIONS

31. Always store the crane in its stowed position for transportation.
 32. Remember the overall height of the entire unit for garage door clearance or when moving under objects with low overhead clearance
 33. Disengage power takeoff (PTO) before moving the vehicle.
(Not applicable to electric-hydraulic cranes.)
 34. Always walk around the vehicle before moving.
 35. Never drive with a load suspended from crane.
 36. Do not take your eyes off a moving load. Look in the direction you are moving.
 37. Never swing a load over people.
 38. Do not stop the load sharply in midair so that it swings like a pendulum. Meter the control levers to avoid this situation. (Not applicable to electric-hydraulic cranes.)
 39. Crane boom length should be kept as short as possible for maximum lifting capacity and greater safety. Longer booms require additional care in accelerating and decelerating the swing motion, and thus slow down the working cycle and reduce productivity.
 40. Keep the load directly and vertically under the boom point at all times. Crane booms are designed to handle vertical loads, not side lifts.
- WARNING:** Never attempt to lift, drag, tow or pull a load from the side. The boom can fail far below its rated capacity.
41. Do not push down on anything with boom extensions; similarly do not lift anything with boom extensions.
 42. Do not lift personnel with any wire rope attachment or hook. There is no implied warranty or responsibility for such purposes.
 43. **WARNING:** In using a safety hook, ALWAYS close the hook throat before lifting a load. Proper attention and common sense applied to the use of the hook and various slings will prevent possible damage to material being hoisted and may prevent injury to personnel.
 44. **WARNING:** Never place a chain link on the tip of the hook and try to lift a load with the hoist.
 45. **WARNING:** Never use a sling bar or anything larger than the hook throat which could prevent the safety latch from closing, thus negating the safety feature.
 46. Do not wrap the wire rope around sharp objects when using winch.
 47. **WARNING:** Never unreel last 5 wraps of cable from drum.

—IMPORTANT—

OPERATING PRACTICES AND WARNINGS

1. Make certain the vehicle meets minimum chassis requirements. (These requirements do not guarantee unit stability)
2. Make certain the crane is installed per factory specifications. Contact your local Distributor or the Auto Crane factory if any questions arise.
3. Keep the vehicle in as level a position as possible while loading or unloading.
4. **ALWAYS** set the vehicle emergency brake before beginning crane operations.
5. **ALWAYS** use outriggers from vehicle to the ground during crane operation. Make sure they are firmly positioned on solid footings.
6. All load ratings are based on crane capacity, **NOT** truck/crane stability.
7. Keep objects and personnel clear of crane path during operation.
8. Keep hoist cable pulled tight at all times.
9. **REMEMBER**, in lifting a heavy load, the weight can create enough tipping momentum to overturn the vehicle.
10. **ALWAYS** keep load as close to ground as possible.
11. Hydraulic hoses need to be inspected frequently for signs of deterioration, and be replaced as required.
12. The hoist hook is an important item that an operator should consider and use properly. It should be checked on a daily basis for distortion or cracks.
13. **ALWAYS** store outriggers before road travel.
14. **WARNING! NEVER OPERATE THE CRANE NEAR ELECTRICAL POWER LINES!** Death or serious injury will result from boom, line, or load contacting electric lines. Do not use crane within 10 feet (3.05m) of electric power lines carrying up to 50,000 volts. One foot additional clearance is required for every additional 30,000 volts or less.
15. **WARNING! NEVER EXCEED** load chart capacities (centerline of rotation to hoist hook).
16. **WARNING! NEVER** un-reel last 5 wraps of cable from drum!
17. **WARNING! NEVER** wrap cable around load!
18. **WARNING! NEVER** attempt to lift or drag a load from the side! The boom can fail far below its rated capacity.
19. **WARNING! NEVER** weld, modify, or use unauthorized components on any Auto Crane unit! This will void any warranty or liability. Also failure of the crane may result.
20. **WARNING! NEVER** place a chain link on the tip of the hook and try to lift a load!
21. **WARNING! NEVER** use a sling bar or anything larger than the hook throat that could prevent the hook latch from closing, thus negating the safety feature!
22. **WARNING!** In using a hook with latch, **ALWAYS** insure that the hook throat is closed before lifting a load! Proper attention and common sense applied to the use of the hoist hook and various slings will prevent possible damage to material being hoisted and may prevent injury to personnel.
WARNING! NEVER hold any Control Select Switch on that will cause unsafe operating conditions!

WARNING!

Auto Crane Company remote controlled, stiff boom cranes are not designed or intended for use on any applications involving the lifting or moving of personnel.

QUALIFICATIONS FOR AND CONDUCT OF OPERATORS AND OPERATING PRACTICES

REFERENCE ASME B30.5a AND OSHA 1910.180 FOR COMPLETE QUALIFICATION REQUIREMENTS

OPERATORS

1. Crane operation shall be limited to personnel with the following minimum qualifications:
 - A. Designated persons.
 - B. Trainees under the direct supervision of a designated person.
 - C. Maintenance and test personnel (when it is necessary in the performance of their duties).
 - D. Inspectors (crane).
2. No one other than the personnel specified above shall enter the operating area of a crane with the exception of persons such as oilers, supervisors, and those specified persons authorized by supervisors whose duties require them to do so and then only in the performance of their duties and with the knowledge of the operator or other persons.

QUALIFICATIONS FOR OPERATORS

1. Operators shall be required by the employer to pass a practical operating examination. Qualifications shall be limited to the specific type of equipment for which examined.
2. Operators and operator trainees shall meet the following physical qualifications:
 - A. Vision of at least 20/30 Snellen in one eye and 20/50 in the other, with or without corrective lenses.
 - B. Ability to distinguish colors, regardless of position, if color differentiation is required for operation.
 - C. Adequate hearing with or without hearing aid for the specific operation.
3. Evidence of physical defects or emotional instability, which render a hazard to operator or others, which in the opinion of the examiner could interfere with the operator's performance, may be sufficient cause for disqualification. In such cases, specialized clinical or medical judgment and tests may be required.
4. Evidence that operator is subject to seizures or loss of physical control shall be sufficient reason for disqualification. Specialized medical

tests may be required to determine these conditions.

5. Operators and operator trainees should have normal depth perception, coordination, and no tendencies to dizziness or similar undesirable characteristics.
6. In addition to the above listed requirements, the operator shall:
 - A. Demonstrate the ability to comprehend and interpret all labels, operator's manuals, safety codes, and other information pertinent to correct crane operations.
 - B. Posses the knowledge of emergency procedures and implement it.
 - C. Demonstrate to the employer the ability to operate the specific type of equipment.
 - D. Be familiar with the applicable safety regulations.
 - E. Understand the operating procedures as outlined by the manufacturer.
 - F. Be thoroughly familiar with the crane and its control functions.
 - G. Understand the operating procedures as outlined by the manufacturer.

CONDUCT OF OPERATORS

1. The operator shall not engage in any practice, which will divert his attention while actually operating the crane.
2. Each operator shall be responsible for those operations under the operator's direct control. Whenever there is any doubt as to safety, the operator shall consult with the supervisor before handling the loads.
3. The operator should not leave a suspended load unattended unless specific precautions have been instituted and are in place.
4. If there is a warning sign on the switch or engine starting controls, the operator shall not close the switch or start the engine until the warning sign has been removed by the appointed person.
5. Before closing the switch or starting the engine, the operator shall see that all controls are in the "OFF"

QUALIFICATIONS FOR AND CONDUCT OF OPERATORS AND OPERATING PRACTICES

or neutral position and all personnel are in the clear.

6. If power fails during operation, the operator shall:
 - A. Move power controls to the "OFF" or neutral position.
 - B. Land the suspended load and boom, if practical.
7. The operator shall be familiar with the equipment and its proper care. If adjustments or repairs are necessary, the operator shall report the same promptly to the appointed person, and shall also notify the next operator.
8. The operator at the start of each shift shall test all controls. If any controls do not operate properly, they shall be adjusted or repaired before operations are begun.
9. Stabilizers shall be visible to the operator while extending or setting unless a signal person assists operator.

OPERATING PRACTICES/HANDLING THE LOAD

1. Size of load.
 - A. No crane shall be loaded beyond the rated load except for test purposes
 - B. The load to be lifted is to be within the rated load of the crane and its existing configuration.
 - C. When loads that are not accurately known are to be lifted, the person responsible for the job shall ascertain that the weight of the load does not exceed the crane rated load at the radius at which the load is to be lifted.
2. Attaching the load.
 - A. The load shall be attached to the hook by means of slings or other devices of sufficient capacity.
 - B. Hoist rope shall not be wrapped around the load.
3. Moving the load.

The operator shall determine that:

 - A. The crane is level and, where necessary, the vehicle/carrier is blocked properly.
 - B. The load is well secured and balanced in the sling or lifting device before it is lifted more than a few inches.
- C. Means are provided to hold the vehicle stationary while operating the crane.
- D. Before starting to lift, the hook shall be positioned over the load in such a manner as to minimize swinging.
- E. During lifting care shall be taken that:
 1. There is no sudden acceleration or deceleration of the moving load.
 2. Load, boom or other parts of the crane do not contact any obstruction.
- F. Cranes shall not be used for dragging loads sideways.
- G. This standard recognizes that telescopic boom cranes are designed and intended for handling materials. They do not meet personnel lift or elevator requirements. Therefore, no lifting, lowering, swinging or traveling shall be done while a person is on the hook or load. Hook attached suspended work platforms (baskets) shall not be used with cranes covered by this standard. Crane manufacturer must approve work platforms attached to the boom.
- H. The operator should avoid carrying loads over people.
- I. When the crane is so equipped, the stabilizers shall be fully extended and set. Blocking under stabilizers shall meet the requirements as follows:
 1. Strong enough to prevent crushing.
 2. Of such thickness, width and length as to completely support the stabilizer pad.
- J. Firm footing under all tires, or individual stabilizer pads should be level. Where such a footing is not otherwise supplied, timbers, cribbing, or other structural members to distribute the load so as to not exceed allowable bearing capacity or the underlying material should provide it.
- K. In transit, the boom shall be carried in stowed position.
- L. When rotating the crane, sudden starts and stops shall be avoided. Rotational speed shall be such that the load does not swing out beyond the radius at which it can be controlled.
- M. The crane shall not be transported with a load on the hook unless recommended by the manufacturer.

QUALIFICATIONS FOR AND CONDUCT OF OPERATORS AND OPERATING PRACTICES

- N. No person should be permitted to stand or pass under a suspended load.
- 4. Stowing procedure.
Follow the manufacturer's procedure and sequence when stowing and un-stowing the crane.

MISCELLANEOUS

OPERATING NEAR ELECTRICAL POWER LINES

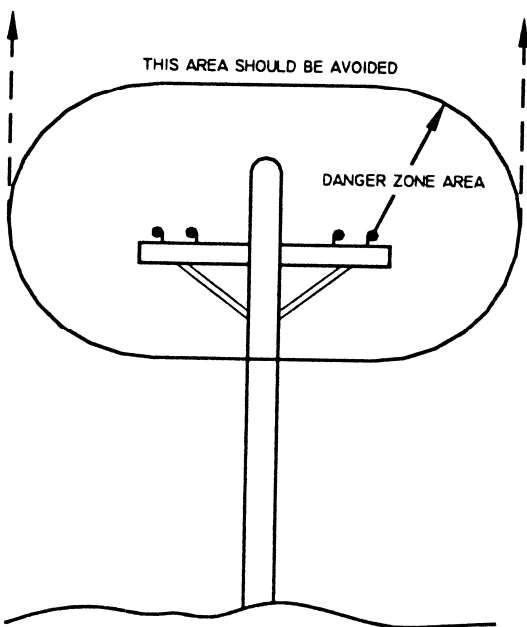

- 1. Cranes shall be operated so that no part of the crane or load enters into the danger zone shown above.

EXCEPTIONS

- A. The danger zone may be entered after confirmation by an appointed person that the electrical distribution and transmission lines have been de-energized and visibly grounded at the point of work; or
- B. The danger zone may be entered if insulating barriers (not a part of nor an attachment to the crane) have been erected to prevent physical contact with the lines.
- 2. For lines rated 50 kV or below, minimum clearance between the lines and any part of the crane or load (including handling appendages) shall be 10-ft. (3m). For higher voltages, see Table 1.

- 3. Caution shall be exercised when working near overhead lines, because they can move horizontally or vertically due to wind, moving the danger zone to new positions.
- 4. In transit with no load and boom lowered the clearance shall be specified in Table 1.
- 5. A qualified signalperson shall be assigned to observe the clearance and give warning before approaching the above limits.
 - A. Any overhead wire shall be considered to be an energized line unless and until the person owning such line or the electrical utility authorities verify that it is not an energized line.
 - B. Exceptions to this procedure are allowed, if approved by the administrative or regulatory authority provided the alternate procedure insures equivalent protection and is set forth in writing.
 - C. Durable signs shall be installed at the operator's station and on the outside of the crane, warning that electrocution or serious bodily injury may occur unless a minimum clearance of 10 ft. (3.0m) between the crane or the load being handled and energized power lines. Greater clearances are required because of higher voltage as stated above. These signs shall be revised but not removed when local jurisdiction requires greater clearances.

TABLE 1			
		minimum required clearance	
normal voltage, kV (phase to phase)		ft	(m)
when operating near high voltage power lines			
over	to 50	10	(3.50)
over	50 to 200	15	(4.6)
over	200 to 350	20	(6.1)
over	350 to 500	25	(7.62)
over	500 to 750	35	(10.67)
over	750 to 1000	45	(13.72)
while in transit with no load and boom lowered			
over	to 0.75	4	(1.22)
over	0.75 to 50	6	(1.83)
over	50 to 345	10	(3.83)
over	345 to 750	16	(4.87)
over	750 to 1000	20	(6.1)

—IMPORTANT— BEFORE OPERATING CRANE

1. Make sure this manual has been thoroughly read by all crane operating personnel and supervisors.
2. A routine inspection of the crane should be mandatory before each operating day. Any defects should be corrected immediately.
3. At a job site the vehicle should be positioned so that the crane can adequately reach the load within the rated capacity (centerline of rotation to hoist hook).
4. Keep the vehicle as level as possible during operation. **CANNOT EXCEED 10° SLOPE.**
5. For electric cranes, **engage emergency brake** and leave ignition on with transmission in neutral (or in park for automatic transmissions). Activate any crane power switches. For Auto Crane units requiring battery and hydraulic operation, **engage emergency brake**, place gear selector in neutral, press clutch, activate PTO, release clutch and after hydraulic fluid is warm, set throttle control to proper engine speed.
6. Always use outriggers from the truck to the ground. Be sure these are firm and adequately positioned. When rotating, **keep load as low to the ground as possible.**
7. Remove the transmitter from cab or storage area. Power transmitter on. Detach hook from dead man. Crane is now ready for operation.
8. Always boom up before rotating so the boom will clear the required boom support.
9. When extending the boom, always maintain clearance between the boom crown and the traveling block or hoist hook.
10. Always observe safe and practical operation to avoid possible accidents. Refer to Safety Tips and Precautions.
11. After completing lifting operations, return the boom to stowed position on the boom support. Avoid unneeded pressure on the boom support.
12. Store transmitter in proper location (in cab or storage area).
13. Return outriggers to stowed position. Make sure they are pinned in place or jacklegs are returned to compartment.
14. Check work area for any tools or equipment not stored.
15. Release throttle control, depress clutch and disengage PTO. Deactivate any crane power switches.
16. Report any unusual occurrence during crane operation that may indicate required maintenance or repair.
17. **NEVER** use two cranes to support a load too large for either crane.

OPERATION OF OUTRIGGERS

HYDRAULIC OUTRIGGERS

1. Shift crane/outrigger control valve to "outrigger" position.
2. Operate the outrigger control valves to position the outriggers.
3. After outriggers are positioned, return crane/outrigger selector to "crane" position.
4. Crane is now ready to operate.

MANUAL OUTRIGGERS

1. Pull lock pins to release jackleg or drop down outrigger and move to outermost lock position.
2. Make sure lock pins are reinstalled properly.
3. Lower outrigger pad to firm ground and adjust foot to take out slack.
4. Crane is now ready to operate.

CRANE OPERATION

TRANSMITTER LAYOUT

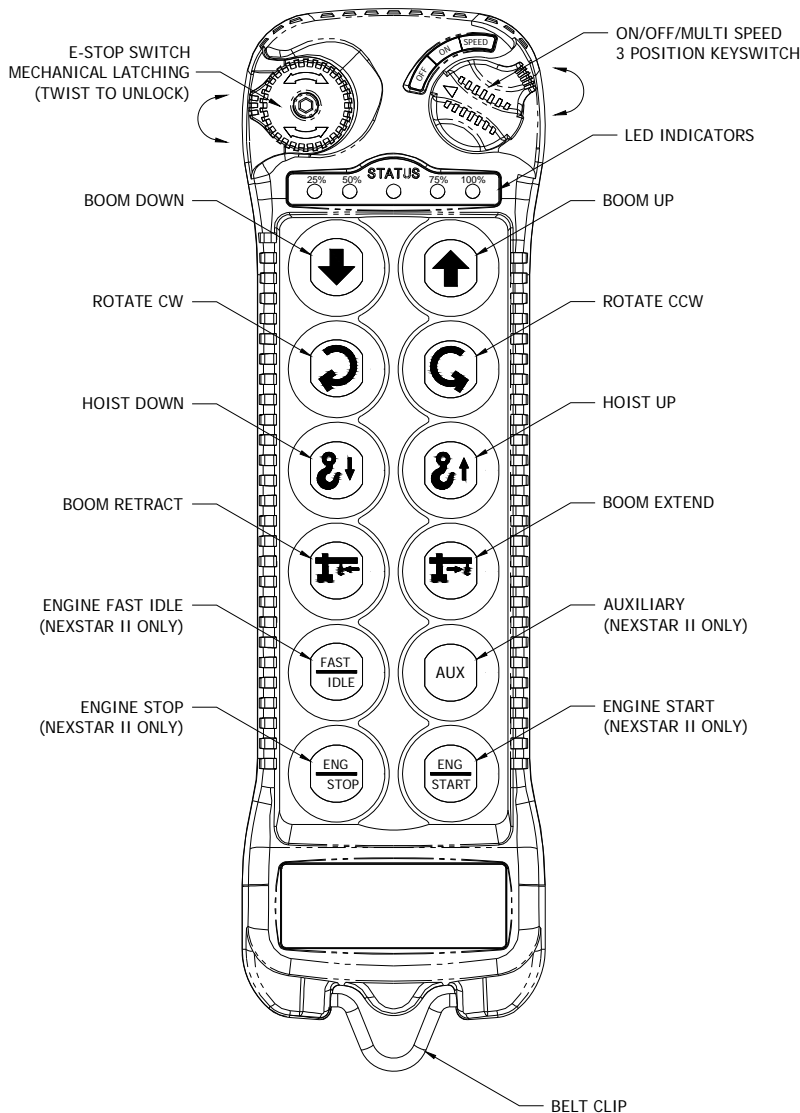

E-stop Switch—Push to activated, Twist to release. Shuts down all outputs from receiver.

On/Off/Multispeed— Detachable key, On, Off, Multispeed, & Start Switch.

Crane Controls—Proportional push button. The function speed increases the more the button is pressed. Functions include Boom Up/Down, Rotate CW-CCW, Hoist Up/Down, Boom Extend, Retract.

Engine Fast-idle (Nexstar II Only) - Activates Fast Idle on Vehicle. (Can be latching or momentary)

Auxiliary (Nexstar II Only) - Sends a latched signal that activates an auxiliary output to operate an external component i.e. compressor, worklights. (Must use a relay to separate auxiliary crane circuit and external component.)

Engine Stop (Nexstar II Only) - Sends a momentary signal from crane to shut down vehicle.

Engine Start (Nexstar II Only) - Sends a momentary signal from crane to start vehicle.

TURNING OFF TRANSMITTER— Move the On/Off/Multi-speed switch to the “off” position

TURNING ON TRANSMITTER— Move the On/Off/Multi-speed switch to the “on” position, then move the On/Off/Multi-speed switch to the “Multi-speed” or “start” position momentarily. The status light should be blinking green when active with no buttons depressed.

REMOVING KEY— Move the On/Off/Multi-speed switch to the “off” position, then move the switch counter-clockwise one position past the “off” position. Once the switch is one position past the “off” position then pull out the switch from the transmitter.

CRANE OPERATION

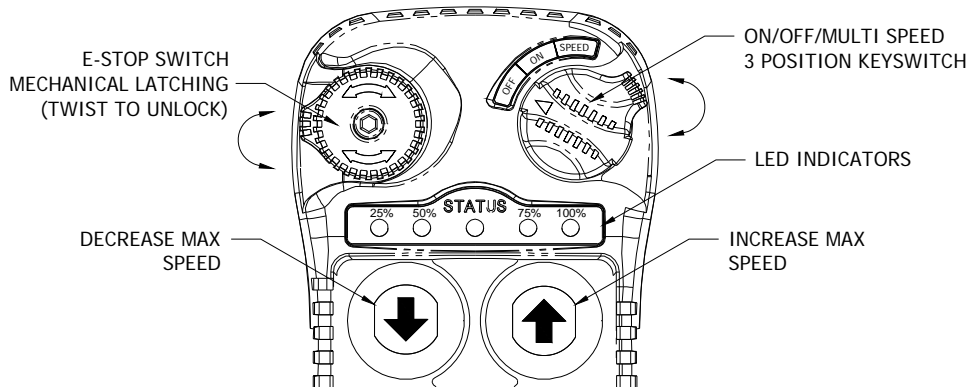

ACTIVATING E-STOP

Press the E-stop Switch.

Note:

1. When E-stop is active, the transmitter will remain on but will not operate any functions. This includes truck and crane functions.
2. **Activating E-stop will not turn the truck off.**
3. There will be an Error Code on the receiver stating "E-stop active".

DEACTIVATING E-STOP

1. Twist to release E-stop.
2. Turn transmitter to the "OFF" position.
3. Once all lights turn off. Turn transmitter to the "ON" position.
4. Turn transmitter to the "START"/"SPEED" position and release

Note:

There is very little height difference in a active and inactive E-stop. To verify E-stop switch is deactivated, twist switch to release.

WAKING UP TRANSMITTER

Turn the transmitter to the "START"/"SPEED" position and release

Note:

The transmitter goes into sleep mode after 5 minutes of inactivity. All truck functions are still available and will remain in the same state. (i.e. Aux function will remain on even when the unit goes to sleep if it was active before unit went to sleep.)

SPEED CONTROL

1. Rotate "ON/OFF/SPEED" switch to the "SPEED" position and hold
2. Press the Boom Up switch in increase max speed or press Boom Down button to decrease. Each time the button is actuated, the max speed increases or decreases to the next 25% range.
3. Release "ON/OFF/SPEED" switch once the desired speed is selected.

Note:

1. Slower speed decreases the max speed and gives more finite control of the proportional push button.
2. Faster speed increases the max speed but give less finite control of the load
3. The LED indicators show the current speed setting of the transmitter.

CRANE OPERATION

RECEIVER LAYOUT

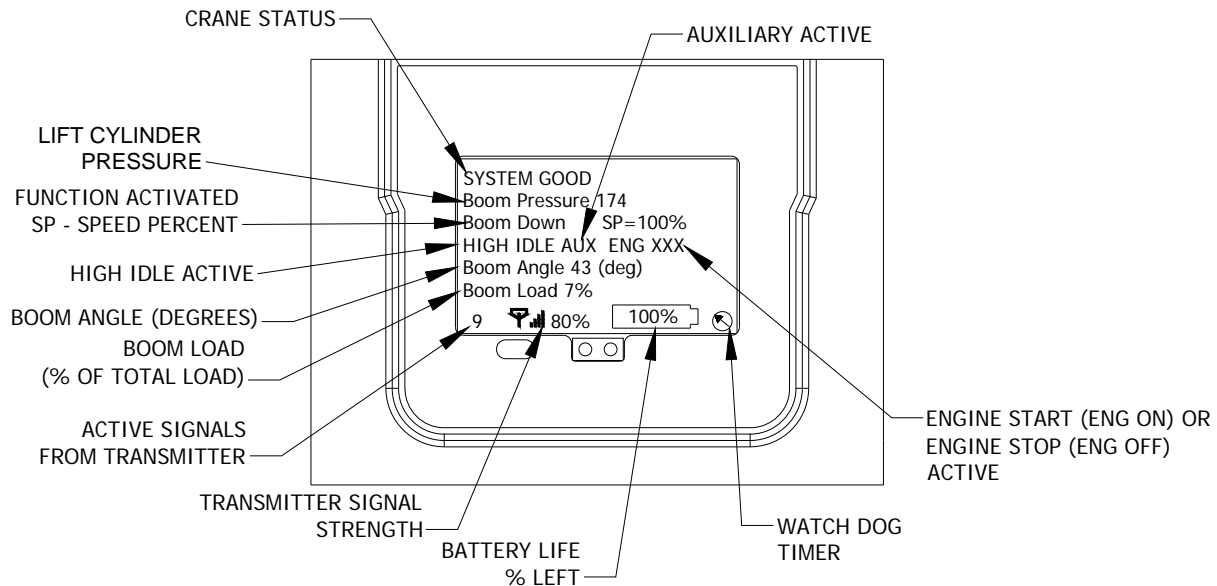

CRANE STATUS—shows current status of the crane. If any alarms are occurring they will be displayed here. Otherwise, it will say system good. **Note: Reference Troubleshooting section for alarm descriptions.**

LIFT CYLINDER PRESSURE—Current pressure in the lift cylinder in PSI

FUNCTION ACTIVATED SP-SPEED PERCENT—Current function activated and percent of max speed for that particular function. Note: If multi-functioning, only last function selected will be displayed.

HIGH IDLE ACTIVE—Shown only when the high idle function is active (Nexstar II Only)

BOOM ANGLE (DEGREES) - Current boom angle in degrees. **Note this value may not match the boom angle decal attached to side of boom since the decal is referenced to the ground not the pedestal.**

BOOM LOAD—Current percent of crane capacity used. **Note: Unloaded this value may be higher than 0% due to boom weight beyond the retracted position.**

ACTIVE SIGNALS FROM TRANSMITTER—Shows current status of transmitter. 0 means the transmitter is not active. It must be turned on, e-stop deactivated, or taken out of sleep mode. 5-6 means the transmitter is active but no function is currently being selected. Receiver is waiting on a command from the user. 9-10 means the transmitter is sending crane function signals to start operating the crane. The user is sending a command for the crane to operate.

TRANSMITTER SIGNAL STRENGTH—Shows the strength of signal coming from transmitter. **Note: approx. distance of transmitter is 300 feet.**

BATTERY LIFE—Percent of transmitter battery life remaining

WATCH DOG TIMER— Should always be spinning. If timer stops spinning contact your AutoCrane representative

ENGINE START/STOP—Shows when the Engine Start or Engine Stop button is being selected. Should only be visible when the corresponding button is being depressed. (Nexstar II Only)

AUXILIARY ACTIVE— Shows when the auxiliary function is active. (Nexstar II Only)

INSPECTION REQUIREMENTS

REFERENCE ASME B30.5a AND OSHA 1910.180 FOR COMPLETE INSPECTION REQUIREMENTS

INSPECTION CLASSIFICATION

1. Initial inspection.

Prior to initial use, all new, altered, modified or extensively repaired cranes shall be inspected by a designated person to insure compliance with provisions of this standard

1. Regular inspection.

Inspection procedure for cranes in regular service is divided into two general classifications based upon the intervals at which inspection should be performed. The intervals in turn are dependent upon the nature of the components of the crane and the degree of their exposure to wear, deterioration, or malfunction. The two general classifications are herein designated as "frequent" and "periodic" with respective intervals between inspections as defined below.

A. Frequent inspection - daily or before each use

B. Periodic inspection - one to twelve-month intervals or as specifically recommended by the manufacturer or qualified person.

DESIGNATED PERSONNEL SHALL PERFORM INSPECTIONS ONLY.

FREQUENT INSPECTION

Inspections should also occur during operation for any deficiencies that might appear between regular inspections. Any deficiencies, such as those listed below, shall be carefully examined and a determination made as to whether they constitute a hazard:

1. Inspect control mechanisms for maladjustment that interferes with proper operation.
2. Inspect control mechanisms for excessive wear of components and contamination by lubricants or other foreign matter.
3. Inspect safety devices for malfunction.
4. Visually inspect all hydraulic hoses, particularly those that flex in normal operation of crane functions.
5. Inspect hooks and latches for deformation, chemical damage, cracks, and wear. Refer to ANSI/ASME B30.10.

6. Inspect for proper rope reeving.

7. Inspect electrical wiring and components for malfunctioning, signs of excessive deterioration, dirt and moisture accumulation.

8. Inspect hydraulic system for proper oil level and leaks.

9. Inspect tires for recommended inflation pressure, cuts and loose wheel nuts.

10. Inspect connecting pins and locking device for wear damage and loose retaining bolts.

11. Inspect rope for gross damage, such as listed below, which may be an immediate hazard.

A. Distortion such as kinking, crushing, un-stranding, birdcaging, main strand displacement, or core protrusion. Loss of rope diameter in a short length or unevenness of outer strands should be replaced.

B. General corrosion.

C. Broken or cut strands.

D. Use care when inspecting sections of rapid deterioration around flange points, crossover points, and repetitive pickup points on drums.

E. Inspect number, distribution, and type of visible broken wires. Reference Rope Maintenance section in the owner's manual.

Continued use of rope depends upon good judgment by a designated person in evaluating remaining strength in a used rope after allowance for deterioration disclosed by inspection. Continued rope operation depends upon this remaining strength.

PERIODIC INSPECTION

Any deficiencies, such as those listed below, shall be carefully examined and determination made as to whether they constitute a hazard:

1. Inspect for deformed, cracked or corroded members in the crane structure and entire boom.
2. Inspect for loose bolts, particularly mounting bolts.
3. Inspect for cracked or worn sheaves and drums.
4. Inspect for worn, cracked, or distorted parts such as pins, bearings, shafts, gears, rollers and devices.
5. Inspect for excessive wear on brake and clutch system parts and lining.

INSPECTION REQUIREMENTS

6. Inspect crane hooks for cracks.
7. Inspect travel steering, braking, and locking devices for malfunction.
8. Inspect for excessively worn or damaged tires.
9. Inspect hydraulic hose, fittings, and tubing for the following problems:
 - A. Evidence of leakage at the surface of the flexible hose or its junction with metal and coupling.
 - B. Blistering, or abnormal deformation to the outer covering of the hydraulic or pneumatic hose.
 - C. Leakage at threaded or clamped joints that cannot be eliminated by normal tightening or recommended procedures.
 - D. Evidence of excessive abrasion or scrubbing on the outer surface of a hose, rigid tube, or fitting. Means shall be taken to eliminate the interference of elements in contact or otherwise protect the components.
10. Inspect hydraulic pumps and motors for the following problems:
 - A. Loose bolts and fasteners.
 - B. Leaks at joints between sections.
 - C. Shaft seal leaks.
 - D. Unusual noises or vibrations.
 - E. Loss of operating speed.
 - F. Excessive heating of the fluid.
 - G. Loss of pressure.
11. Inspect hydraulic valves for the following problems:
 - A. Cracks in valve housing.
 - B. Improper return of spool to neutral position.
 - C. Leaks at spools or joints.
 - D. Sticking spools.
 - E. Failure of relief valves to attain or maintain correct pressure setting.
 - F. Relief valve pressure shall be checked as specified by the manufacturers.
12. Inspect hydraulic cylinders for the following problems:
 - A. Drifting caused by fluid leaking across piston.
 - B. Rod seals leaking.
 - C. Leaks at welding joints.
 - D. Scored, nicked, or dented cylinder rods.
 - E. Damaged case (barrel).
 - F. Loose or deformed rod eyes or connecting joints.
13. Inspect hydraulic filters for evidence of rubber particles on the filter elements indicating possible hose, "O" ring, or other rubber component deterioration. Metal chips or pieces on the filter may denote failure in pumps, motors, or cylinders. Further inspection will be necessary to determine the origin of the problem before corrective action can be taken.
14. Inspect labels to confirm correct location and legibility. Reference decal layout in this manual for proper location of decals.
15. **Rope Inspections need not be at equal calendar intervals and should be more frequent as the rope approaches the end of useful life.** A qualified person shall inspect the wire rope based on such factors as:
 - A. Expected rope life as determined by experience on the particular installation or similar installations.
 - B. Severity of environment.
 - C. Percentage of capacity lifts.
 - D. Frequency rates of operation.
 - E. Exposure to shock loads.

This inspection shall cover the entire length of the rope. Only the surface wires need to be inspected and no attempt should be made to open the rope. Any deterioration resulting in appreciable loss of original strength shall be noted and determination made as to whether use of the rope would constitute a hazard. A few notable deterioration points are listed below:

 - A. Reduction of rope diameter below nominal diameter due to loss of core support.
 - B. Internal or external corrosion.
 - C. Wear of outside wires.
 - D. Severely corroded, cracked, bent, worn, or improperly applied connections.

CRANES NOT IN REGULAR USE

A crane, which has been idle for a period of over one month or more, shall be given an inspection conforming to the "initial" and "regular" inspection requirements of this section.

INSPECTION RECORDS

Dated records of periodic inspection should be made on critical items such as brakes, crane hooks, rope, cylinders, and relief pressure valves.

TESTING REQUIREMENTS

REFERENCE ASME B30.5a AND OSHA 1910.180 FOR COMPLETE INSPECTION REQUIREMENTS

TESTING SHALL BE PERFORMED BY DESIGNATED PERSONNEL ONLY.

Prior to initial use, all new, altered, modified, or extensively repaired cranes shall be tested for compliance with the operational requirements of this crane.

Test requirements:

1. Test all functions to verify speed and operation.
2. Check that all safety devices are working properly.
3. Confirm operating controls comply with appropriate function labels.
4. Test loads shall not exceed 110% of the manufacturer's load rating.
5. Written reports shall be maintained showing test procedures and confirming the adequacy of repairs

GENERAL REPAIRS AND MAINTENANCE

REFERENCE ASME B30.5a AND OSHA 1910.180 FOR COMPLETE MAINTENANCE AND REPAIR REQUIREMENTS

A preventative maintenance program should be established based on this section and all replacement parts should be obtained from AutoCrane Company.

For replacement parts contact your local authorized distributor.

MAINTENANCE PRECAUTIONS

1. Place crane where it will cause the least interference with other equipment or operations.
2. Verify all controls are in the "off" position and all operating features secured from inadvertent motion by brakes, pawls, or other means.
3. The means for starting the crane shall be rendered inoperative.
4. The boom should be secured in place before maintenance.
5. Relieve hydraulic oil pressure from all hydraulic circuits before loosening or removing hydraulic components.
6. Warning or "OUT OF ORDER" signs shall be placed on all crane controls.
7. After adjustments and repairs have been made, the crane shall not be returned to service until all guards have been reinstalled, trapped air removed from hydraulic system (if required), safety devices reactivated, and maintenance equipment removed.

ADJUSTMENTS AND REPAIRS

1. Any hazardous conditions disclosed by the inspection requirements shall be corrected before operation of crane is resumed. Only designated personnel shall do adjustments and repairs.
2. Adjustments shall be maintained to assure correct functioning of components, the following are examples:
 - A. Functional operating mechanism.
 - B. Safety devices.
 - C. Control systems.
3. Repairs or replacements shall be provided as needed for operation, the following are examples:
 - A. Critical parts of functional operating mechanisms which are cracked, broken, corroded, bent, or excessively worn.
 - B. Critical parts of the crane structure which are cracked, bent, broken, or excessively corroded.
 - C. Crane hooks showing cracks, damage, or corrosion shall be taken out of service. Repairs by welding are not recommended.

4. If bleeding the hydraulic system is required, run each crane function until smooth operation of that particular function is noticeable.

LUBRICATION

All moving parts of the crane, for which lubrication is specified, should be regularly lubricated per the manufacturer's recommendations and procedures.

Reference Lubrication and Maintenance Schedule in this manual.

ROPE REPLACEMENT

No precise rules can be given for determination of the exact time for replacement of rope, since many variable factors are involved.

1. Conditions such as the following shall be reason for questioning continued use of the rope or increasing the frequency of inspection:
 - A. In running ropes, six randomly distributed broken wires in one lay or three broken wires in one strand in one lay.
 - B. One outer wire broken at the contact point with the core of the rope structure and protrudes or loops out of the rope structure. Additional inspection of this section is required.
 - C. Wear of one third of the original diameter of the outside individual wire.
 - D. Kinking, crushing, bird caging, or any other damage resulting in distortion of the rope structure.
 - E. Evidence of any heat damage from any cause.
 - F. Reduction from nominal diameter of more than 1/64 in. (0.4mm) for diameters up to and including 5/16 in. (8 mm), 1/32 in. (0.8 mm) for diameter 3/8 in. (9.5 mm) to and including 1/2 in. (13 mm), 3/64 in. (1.2 mm) for diameter 9/16 in. (14.5 mm) to and including 3/4 in. (19 mm), 1/16 in. (1.6 mm) for diameter 7/8 in. (22 mm) to and including 1 1/8 in. (29 mm), 3/32 in. (2.4 mm) for diameters 1 1/4 in. (32 mm) to and including 1 1/2 in. (38 mm).
 - G. In standing ropes, more than two broken wires in one lay in sections beyond end connections or more than one broken wire at an end connection.

GENERAL REPAIRS AND MAINTENANCE

2. Replacement rope shall have a strength rating at least as great as the original rope furnished or recommended by AutoCrane. A rope manufacturer, AutoCrane, or a qualified person shall specify any deviation from the original size, grade, or construction.

ROPE MAINTENANCE

1. Rope should be stored to prevent damage or deterioration.
2. Unreeling or uncoiling of rope shall be done as recommended by the rope manufacturer and with care to avoid kinking or inducing twist.
3. Before cutting a rope, seizing shall be placed on each side of the place where the rope is to be cut to prevent unlaying of the strands. On pre-formed rope, one seizing on each side of the cut is required. On non-preformed ropes of 7/8 in. (22 mm) diameter or smaller, two seizings on each side of the cut are required, and for non-preformed rope 1 in. (25 mm) diameter or larger, three seizings on each side of the cut are required.
4. During installation care should be exercised to avoid dragging of the rope in the dirt or around objects that will scrape, nick crush or induce sharp bends in it.
5. Rope should be maintained in a well-lubricated condition. It is important that lubricant applied as a part of a maintenance program shall be compatible with the original lubricant and to this end the rope manufacturer should be consulted. Lubricant applied shall be the type that does not hinder visual inspection. Those sections of rope that are located over sheaves or otherwise hidden during inspection and maintenance procedures require special attention when lubricating rope. The object of rope lubrication is to reduce internal friction and to prevent corrosion.
6. When an operating rope shows greater wear or well-defined localized areas than on the remainder of the rope, rope life can be extended in some cases by shifting the wear to different areas of the rope.

MAINTENANCE OF BATTERIES

Maintenance of Auto Crane unit batteries differs very little from the generally prescribed maintenance of any lead acid battery. All batteries must be kept properly charged, properly filled with water, and relatively clean.

Keep Properly Charged

Many things affect the proper charge to a battery, such as:

1. Regulator settings.
2. Proper tightness of belts on the alternator or generator.
3. Good, clean connections of all cables and wires at the following places:
 - a. Battery.
 - b. Regulator.
 - c. Starting motor.
 - d. Alternator or generator.
 - e. Ground connections (most important).

It is of extreme importance to keep the battery as fully charged as possible without overcharging, especially when vehicles are left outside for extended periods in extremely cold climates. A battery can freeze. Freezing points for various specific gravities of acid are as follows:

Specific Gravity (Corrected to 80°F)	Freezing Temp. Degrees F.
1.280	-90°F
1.250	-62°F
1.200	-16°F
1.150	5°F
1.100	19°F

As shown, a half-charged battery (about 1.100 specific gravity) cannot stand for any length of time at 20°F or it will freeze.

The main reason for keeping the battery as fully charged as possible without over-charging is to insure that power is available even though the vehicle has been standing for some time.

Keep Properly Filled with Water

The battery should *always* be properly filled with water. If the electrolyte level is allowed to fall below the top of the plates, the results become threefold:

1. The exposed portion of the plate will become sulfated.

2. The portion of the plate exposed is not usable.
3. That portion of the acid remaining becomes more concentrated and may cause more rapid deterioration of the remaining parts of the battery.

Keep A Relatively Clean Battery

The battery should be kept clean. Batteries filled with acid and which are not in use self-discharge to a limited degree because of the nature of the materials within the battery. If dirt is allowed to collect on the top of the battery (and this dirt absorbs moisture) and electrical path can be set up between the various terminals of the battery and the ground. Once such a path has been established, the self-discharge of the battery is accelerated. This also accelerates corrosion of the battery cables at the terminals.

Periodic Maintenance is Needed

A definite program of periodic maintenance of all batteries should be conducted on a regular basis. Periodic maintenance includes:

1. Checking belts for tightness on the charging equipment.
2. Checking battery electrolyte levels.
3. Checking cables for good connections.
4. Cleaning where corrosion is apparent.

When corrosion is cleaned off, the cable terminals and battery terminals should be coated with a light coating of petroleum jelly before they are replaced. When terminals are cleaned, the top of the battery should be cleaned with a mild solution of soda water.

Low Maintenance Batteries (Maintenance Free)

Low maintenance batteries should not be used on AutoCrane Cranes or trucks equipped with Auto-Crane Cranes. The batteries are not designed for "deep" discharge.

Testing Your Battery

If the condition of the battery is in question, it should be removed from the vehicle, taken to the shop, and allowed to reach room temperature. It should then be recharged until specific gravity readings taken at one-half hour intervals. If the specific gravity readings are fairly uniform, the battery should be checked with a high rate tester. Use the tester in accordance with the manufacturer's instructions. The high rate tester is the best method to test a questionable battery.

MAINTENANCE OF BATTERIES

If, after charging, it is noted that the specific gravity reading of one cell is 30 points less than any of the other cells, it may be assumed that the cell is bad and that the battery should be replaced. If all cells are uniform but not up to full charge, a low rate of charge should be attempted for an extended time. This usually will recover a badly sulfated battery.

Replacing a Battery

If it is necessary to replace a battery, and a dry charge battery is used, the following procedure applies:

1. Fill the battery with electrolyte of the proper specific gravity.

2. Place the battery on charge according to the manufacturer's instructions.

It is essential that the second step above be followed to ensure that the battery going on the vehicle is fully charged.

It is also very important that the battery hold-downs be checked periodically to insure that the batteries are properly positioned to avoid vibration problems, breakage of cables or terminals. Care must be taken to avoid cracking or breaking containers or covers by tightening hold-down fixtures excessively. They also must not be so loose that breakage results from a hold-down that is too loose.

10006H

LUBRICATION & MAINTENANCE SCHEDULE

SERVICE PERFORMED	DAY	WKLY	3 MOS	6 MOS	YEAR	NOTES
LOAD HOOK	X					INSPECT HOOK & LATCH FOR DEFORMATION, CRACKS, & CORROSION
CABLE DRUM	X					MAKE SURE CABLE IS WOUND EVENLY ON DRUM
HOIST / BOOM CABLE	X					CHECK FOR FLATTENING, KINKS, & BROKEN STRANDS, SEE MANUAL
HYD. HOSES	X					VISUAL INSPECTION
HYD. FLUID	X					CHECK FLUID LEVEL
PIN RETAINING BOLTS	X					CHECK TORQUE TO 23 FT-LBS (GRADE 5), 35 FT-LBS (GRADE 8) AS REQUIRED
MOUNTING BOLTS		X				CHECK TORQUE TO 501 FT-LBS AS REQUIRED
ROTATION RING GEAR		X				LUBE WITH MOBILETAC LL, OR LUBRIPLATE P/N 15263, OR EQUAL
SHEAVE BEARINGS		X				SEALED BEARING, REPLACE IF ROUGH OR LOOSE
ALL OTHER BOLTS		X				CHECK TIGHTEN AS REQUIRED
LIFT CYLINDER BEARINGS			X			GREASE WITH MOBILEPLEX EP-2 OR EQUIVALENT @ ZERKS
ROTATION BEARING			X			GREASE WITH MOBILEPLEX EP-2 OR EQUIVALENT @ ZERKS
ROTATION BEARING BOLTS			X			CHECK TORQUE TO 170 FT-LBS (HEX HEAD) 180 FT-LBS (SOCKET HEAD) AS REQUIRED
ROTATION GEAR BOX			X			CHECK TORQUE TO 90 FT-LBS (SOCKET HEAD) AND 55 FT-LBS (HEX HEAD) AS REQUIRED
ROTATION GEAR BOX				X		EP GEAR LUBE SAE 80-90
HYDRAULIC FLUID					X	DRAIN, FLUSH, AND REFILL WITH MOBILE DTE 13 OIL
BOOM SLIDE PADS	PADS GREASED WHEN REPLACED					
FILTER, VALVE BLOCK	REPLACE ANNUALLY OR EVERY 200 HOURS OF OPERATION. AS DIRECTED BY DIRTY FILTER SENSOR (NEXSTAR II ONLY)					
FOR ADDITIONAL INFORMATION SEE:	1) OWNER'S MANUAL 2) OSHA SECTION 1910.180 3) ANSI B30.5-1989					

CAUTION: Routine maintenance insures trouble-free operation and protects your investment. All warranties are void if maintenance is neglected.

10006H

LUBRICATION & MAINTENANCE SCHEDULE

NOTES:

1. Use only authorized parts. Any damage or malfunction caused by the use of unauthorized parts is not covered by Warranty or Product Liability.
2. Once a bolt has been torqued to its rated capacity and then removed; the bolt should be replaced with a new one.
3. Auto Crane Company recommends that this crane be serviced per "Crane Inspection Log" P/ N 999978. These logs should be filled in at the intervals noted and kept as a permanent record. Additional copies are available from your local distributor.

LUBE POINTS

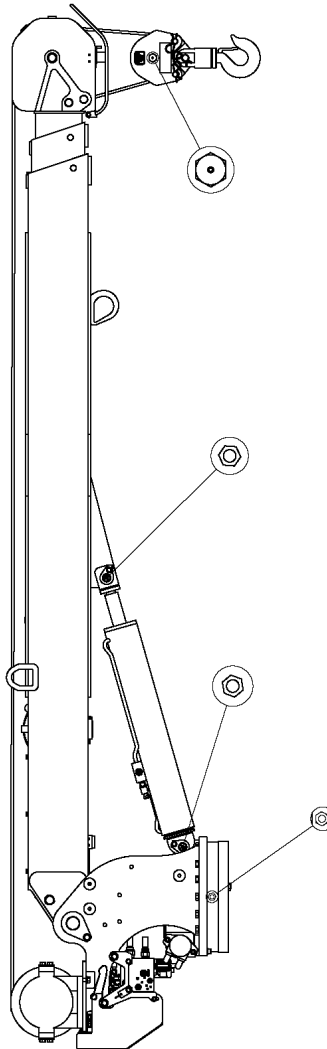

10006H

SAFETY DECAL SECTION

PART NO.:	040579000
DECAL:	OPERATING INSTRUCTIONS
FUNCTION:	To inform the operator of the proper procedure to follow for safe operation of the crane.
USED ON:	All Cranes
QUANTITY:	1
PLACEMENT:	Right side plate

⚠ CAUTION

1. INSPECT VEHICLE AND CRANE INCLUDING OPERATION, PRIOR TO USE DAILY.
2. DO NOT USE THIS EQUIPMENT EXCEPT ON SOLID, LEVEL SURFACE WITH OUTRIGGERS PROPERLY EXTENDED AND CRANE MOUNTED ON FACTORY-RECOMMENDED TRUCK.
3. BEFORE OPERATING THE CRANE, REFER TO MAXIMUM LOAD (CAPACITY) CHART ON CRANE FOR OPERATING (LOAD) LIMITATIONS.
4. OPERATE ALL CONTROLS SLOWLY AND SMOOTHLY.
5. KEEP LOAD UNDER BOOM TIP. DO NOT SIDE LOAD BOOM OR DRAG LOADS. AVOID FREE SWINGING LOADS.
6. DO NOT OPERATE, WALK OR STAND BENEATH BOOM OR A SUSPENDED LOAD.
7. KEEP AT LEAST 5 WRAPS OF LOADLINE ON HOIST DRUM.
8. FOR TRAVELING, BOOM AND OUTRIGGERS MUST BE IN THE STOWED POSITION.
9. ALL REMOVABLE PENDANTS MUST BE STORED IN CAB OR TOOL COMPARTMENT WHEN CRANE IS NOT IN USE.

P/N 040579

PART NO.:	040580000
DECAL:	OPERATING TRAINING
FUNCTION:	To inform the operator of the need to receive proper training before using the crane.
USED ON:	All Cranes
QUANTITY:	1
PLACEMENT:	Right side plate

⚠ DANGER

AN UNTRAINED OPERATOR
SUBJECTS HIMSELF AND
OTHERS TO

DEATH OR SERIOUS INJURY

- 1.) YOU MUST HAVE BEEN TRAINED IN THE OPERATION OF THIS CRANE, AND
- 2.) YOU MUST KNOW AND FOLLOW THE SAFETY AND OPERATING RECOMMENDATIONS CONTAINED IN THE MANUFACTURER'S MANUAL, YOUR EMPLOYER'S WORK RULES AND APPLICABLE GOVERNMENT REGULATIONS.

P/N 040580

PART NO.:	040632000
DECAL:	TAMPERING WITH OVERLOAD DEVICE
FUNCTION:	To inform the operator that tampering with the overload device may cause a unit failure or possible personal injury.
USED ON:	All Cranes equipped with a load sensor
QUANTITY:	1
PLACEMENT:	Right side of valve sensor.

⚠ WARNING

TAMPERING WITH OVERLOAD DEVICE VOIDS WARRANTY. OVERLOADED CRANE MAY HYDRAULICALLY RELEASE AND LET LOAD DOWN TO GROUND.

OVERLOAD PROTECTION DEVICE CANNOT FUNCTION WITH BOOM BELOW HORIZONTAL (0°). HOIST UP, BOOM DOWN, AND EXTEND OUT WILL BE INOPERATIVE WHEN CRANE IS IN OVERLOAD CONDITION.

P/N 040632

10006H SAFETY DECAL SECTION

PART NO.:	040529000
DECAL:	ELECTROCUTION HAZARD
FUNCTION:	To inform the operator of the hazard involved with contacting electrical power lines with crane boom.
USED ON:	All Cranes
QUANTITY:	2
PLACEMENT:	Both sides of end of lower boom

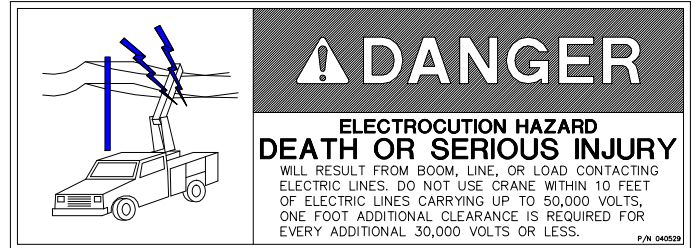

PART NO.:	040517000
DECAL:	STAY CLEAR OF BOOM
FUNCTION:	To inform the operator of the hazard of proximity or contact with the crane boom during operation.
USED ON:	All Cranes
QUANTITY:	2
PLACEMENT:	Both sides of crown

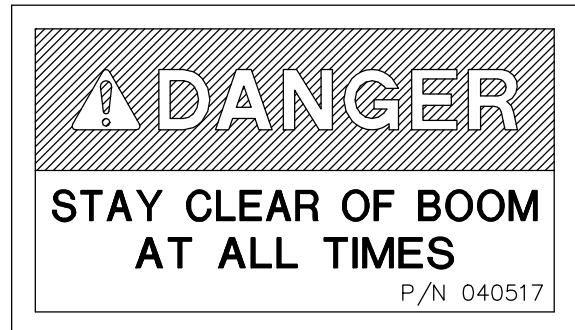

PART NO.:	040518000
DECAL:	STAY CLEAR OF LOAD
FUNCTION:	To inform the operator of the hazard of proximity or contact with the crane load during operation.
USED ON:	All Cranes
QUANTITY:	2
PLACEMENT:	Both sides of traveling block



10006H

SAFETY DECAL SECTION

PART NO.:	040587000	USED ON:	All cranes equipped with a load sensor.
DECAL:	LOAD SENSOR, DON'T TAMPER	QUANTITY:	2
FUNCTION:	To inform the operator that the load sensor is pre-set and that tampering with the sensor may cause potentially hazardous situation.	PLACEMENT:	Both sides of the lift cylinder near the load sensor
USED ON:	All cranes equipped with a load sensor.		
QUANTITY:	1		
PLACEMENT:	On the lift cylinder near the load sensor		

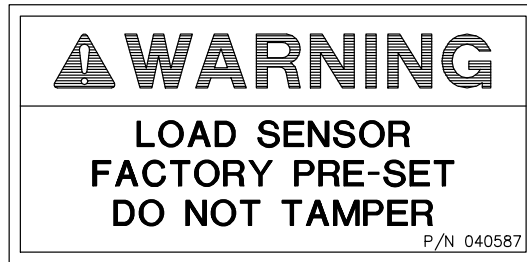

PART NO.:	040519000	USED ON:	All cranes.
DECAL:	SCISSORS POINT	QUANTITY:	2
FUNCTION:	To inform the operator of possible danger at scissors point on crane.	PLACEMENT:	Both sides of the lift cylinder

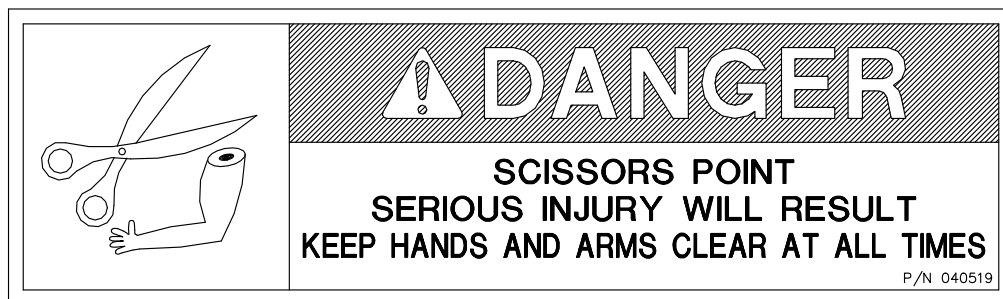

10006H

SAFETY DECAL SECTION

PART NO.:	460169000	USED ON:	All Cranes equipped with FM controls.
DECAL:	REMOTE CONTROL	QUANTITY:	1
FUNCTION:	To inform the operator of failure to follow the safety precautions may result in equipment failure or serious personal injury.	PLACEMENT:	FRONT OF POWER UNIT



WARNING

REMOTE CONTROL SAFETY PRECAUTIONS

READ THE OPERATOR'S MANUAL before using the Remote Control System. Failure to follow the safety precautions may result in equipment failure or serious personal injury.

MAKE SURE MACHINERY AND SURROUNDING AREA IS CLEAR BEFORE OPERATING REMOTE CONTROL SYSTEM. Do not activate the Remote Control System unless it is safe to do so.

TURN OFF THE RECEIVER POWER BEFORE WORKING ON THE MACHINE. Always disconnect the Remote Control System before doing any maintenance to prevent accidental operation of the machine.

DO NOT MODIFY EQUIPMENT WITHOUT WRITTEN APPROVAL FROM THE MANUFACTURER.

CARE

KEEP DRY. Do not clean the Transmitter / Receiver under high pressure. If water or other liquids get inside the Transmitter battery or Receiver compartment, immediately dry the unit. Remove the case and let the unit air dry.

Clean the unit after operation using a damp cloth to remove any mud, dirt, concrete, etc. from the unit and prevent clogging of buttons, switches, etc.

MAINTENANCE / WELDING

DISCONNECT THE RECEIVER BEFORE WELDING ON THIS MACHINE. Failure to disconnect will result in the destruction of the Receiver.

460169000 A

NOTES

10006H DECAL LAYOUT

P/N: 460178021

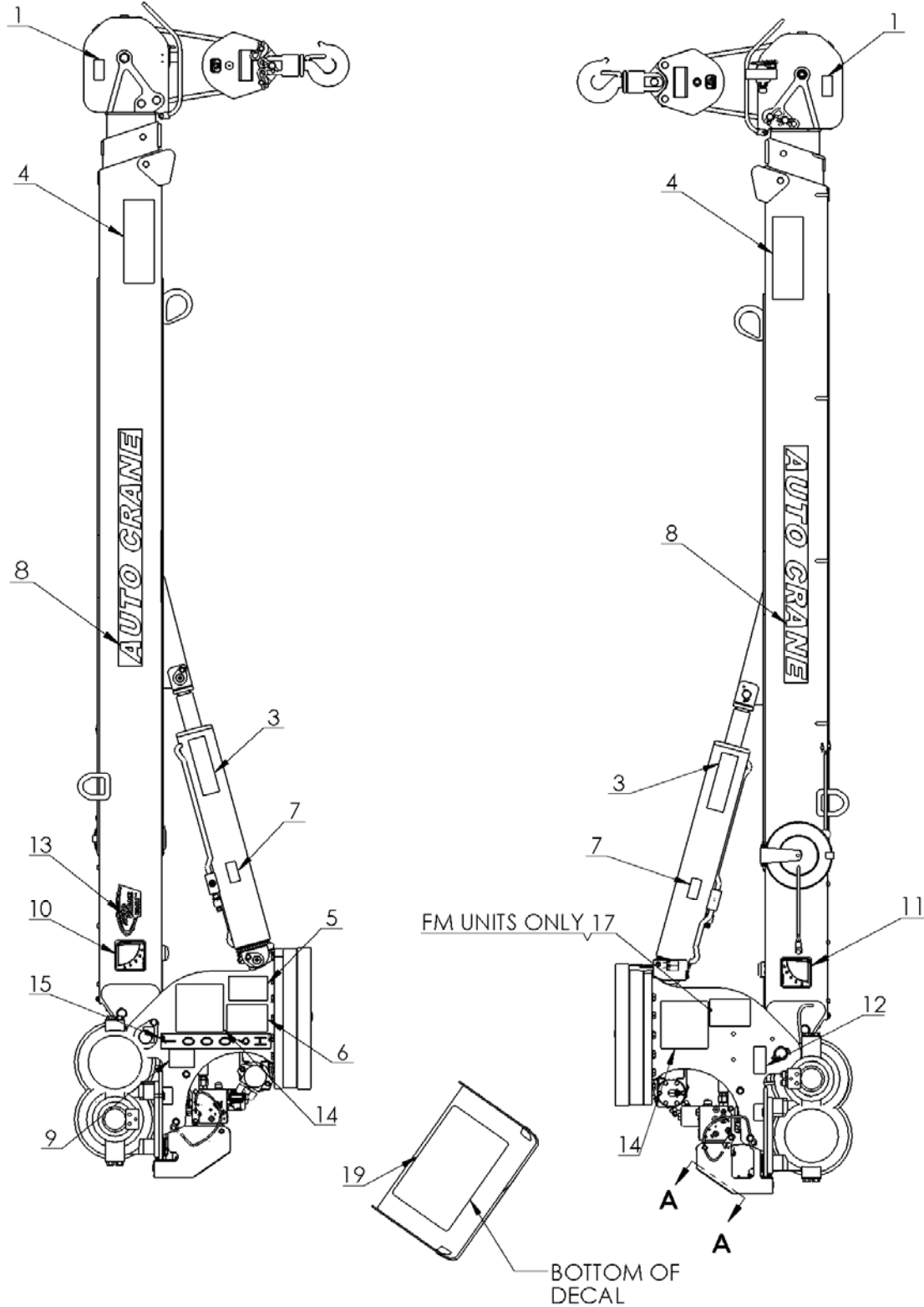

SECTION A-A

10006H DECAL LAYOUT

P/N: 460178021

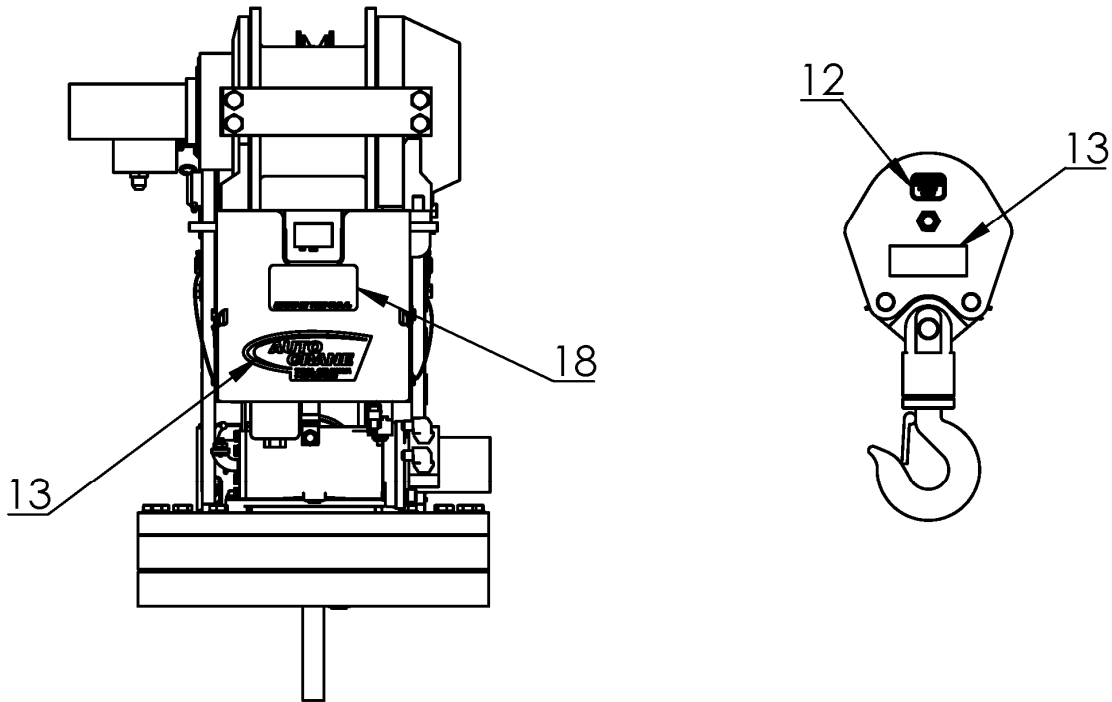

ITEM NO.	QTY	PART NUMBER	DESCRIPTION
1	2	40517000	DECAL STAY CLEAR OF BOOM
2	2	40518000	DECAL STAY CLEAR OF LOAD
3	2	40519000	DECAL DANGER SCISSOR POINT
4	2	40529000	DECAL DANGER "ELECTROCUTION HAZARD" POWER LINE
5	1	40579000	DECAL OPERATION INSTRUCTIONS
6	1	40580000	DECAL TRAINED OPERATOR
7	2	40587000	DECAL WARNING LOAD SENSOR
8	2	40624000	DECAL AUTO CRANE
9	1	40632000	DECAL WARNING - OVERLOAD
10	1	320318000	DECAL ANGLE INDICATOR CS
11	1	320318001	DECAL ANGLE INDICATOR SS
12	1	330622000	DECAL SERIAL NO
13	2	360034000	DECAL AUTO CRANE LOGO
14	2	460178026	DECAL, LOAD CHART 10006H NEXSTAR
15	1	460088000	DECAL, 10006H
16	2	460128000	DECAL MAX BLOCK LOAD
17	1	460169000	DECAL WARNING, REMOTE CONTROL
18	1	40824000	DECAL, AMERICAN FLAG, MADE IN THE U.S.A.
19	1	366823301	DECAL, MANUAL OVERRIDE PROCEDURES, GS HYDRAULICS, LARGE H-MODELS

10006H GENERAL DIMENSIONS

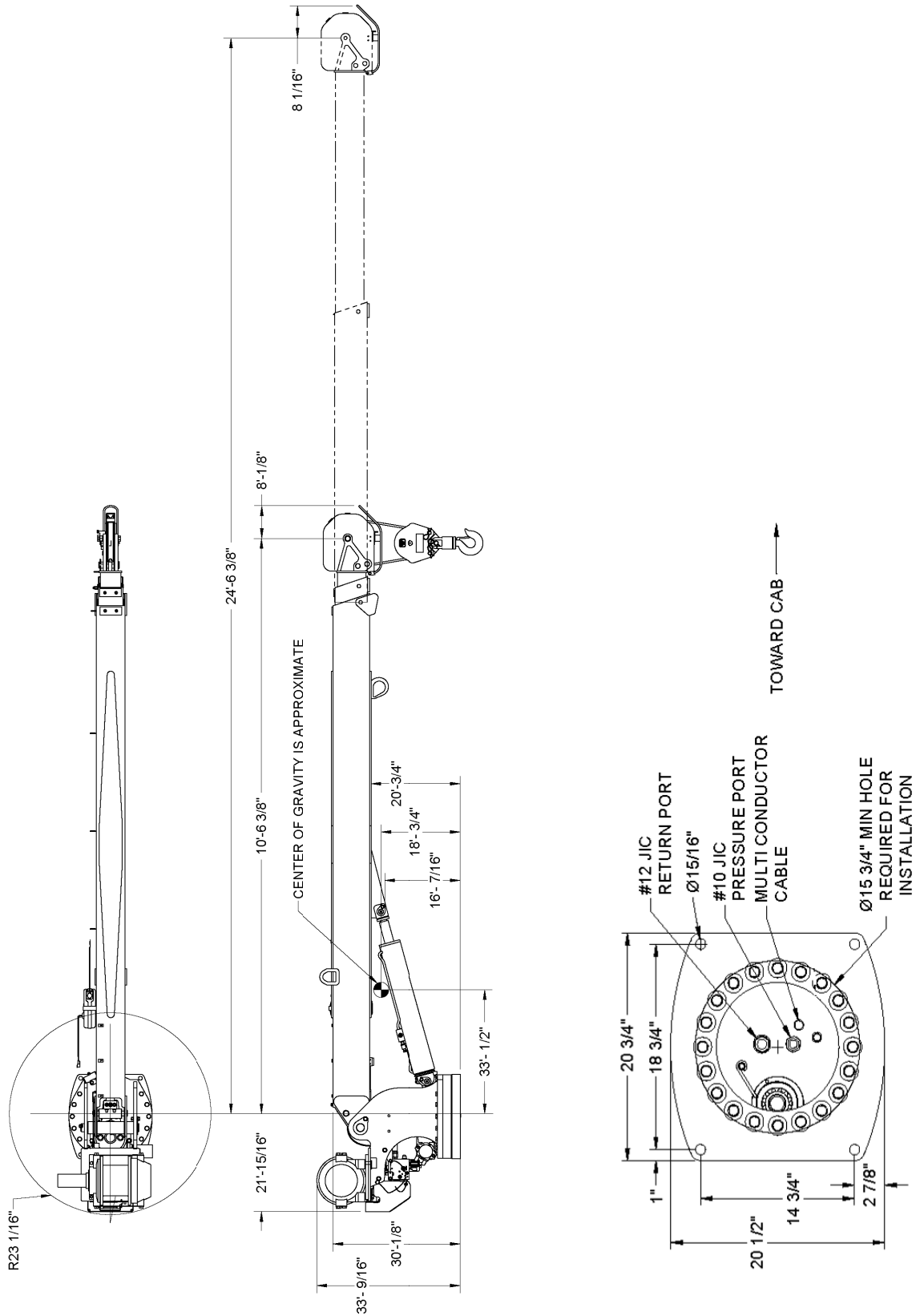

NOTES

10006H

MOUNTING AND INSTALLATION

1. Check to make sure the following items are with your crane. Please note the different, model specific, quantities.

QTY.	PART NO.	Description
4	15104000	SCREW HX HD 7/8UNF X 5 GR 8
4	22200000	WASHER SP LK 7/8 CP
4	18900000	NUT HX 7/8 NF8P GR8
1	480689000	FUSE 15 AMP TIME-DELAY
1	480688000	FUSE HOLDER IN-LINE WATERPROOF
120 in	800596000	WIRE 16G 600V 1C YEL
6	634401000	TIE CABLE-MEDIUM
6	750738000	STICK-ON, CABLE TIE MOUNT
5	320357000	TERMINAL NON-INS S/O W/L
1	340638000	CONDUCTOR POWER
1	320355000	RELAY DROP OUT
1	320363000	PLUG TERMINAL CONNECTOR
1	460178010	10006H MANUAL NEXSTAR CONTROLS
1	460178026	DECAL, LOAD CHART 10006H NEXSTAR

2. Pressure and return hoses are not furnished with this crane. The hoses must be provided by the installer and the lengths determined at installation.

REQUIREMENTS FOR INSTALLATION USING 23 GALLON RESERVOIR(*)

- RETURN LINE** FROM CRANE TO RESERVOIR (IN COMPARTMENT): -12 SAE 100R2 (OR EQUIVALENT). HOSE LENGTH IS DETERMINED BY INSTALLER. RETURN LINES LONGER THAN 6 FEET SHOULD BE SIZE -12. HOSE END FITTINGS ARE -10 JIC FEMALE SWIVEL (CRANE END) AND -10 JIC FEMALE SWIVEL (RESERVOIR END).
- PRESSURE LINE** FROM PUMP TO CRANE: -10 SAE 100R12 (OR EQUIVALENT) WITH A **3,000 PSI MINIMUM WORKING PRESSURE**. HOSE LENGTHS IS DETERMINED BY INSTALLER. HOSE END FITTINGS ARE BOTH -10 JIC FEMALE SWIVEL.

(*) NOTE: 23 GAL RESERVOIR IS MINIMUM REQUIREMENT FOR CRANE ONLY. THE ADDITION OF OTHER AUXILLARY EQUIPMENT WILL REQUIRE ADDITIONAL CAPACITY.

CAUTION—FAILURE TO USE CLEAN HYDRAULIC HOSES AND COMPONENTS MAY CONTAMINATE THE CRANE AND HYDRAULIC SYSTEM AND VOID WARRANTY.

3. Crane must be provided with a flow of 15 to 19 gallons per minute and a working pressure of 3,000 PSI. Excess flow will cause erratic operation, and too little flow will cause poor crane operation.
(* NOTE—Flow and pressure mentioned above are required at the crane . Pump must be sized appropriately to accommodate back pressures and pressure loses in the hydraulic system
4. Vehicle should meet minimum GVW rating of 26,000 pounds.
5. The vehicle **MUST** be equipped with an engine speed control and tachometer.
6. Make sure mounting surface is properly reinforced to withstand 60,000 ft-lb capacity loading of crane and that outriggers are used to provide total stability for the truck.

10006H

MOUNTING AND INSTALLATION

7. A 13 1/2" diameter hole should be cut out of mounting location (centered with mounting bolts) for access to hydraulic connections.
8. Make sure the mounting bolts are 7/8" dia, grade 8-UNF. Torque bolts to 501 ft-lbs.
9. When crane is not in operation, a boom support should always be used. Traveling block should be connected to hook loop.
10. Electrical hookup:
 - Wiring-cable from base of crane.
 - A. CONNECT THE BLACK WIRE TO THE BATTERY NEGATIVE (GROUND).
 - B. CONNECT THE RED WIRE TO FUSED 12VDC POWER. 12VDC POWER SHOULD BE SUPPLIED THROUGH A DEDICATED SWITCH THAT IS POWERED ONLY WHEN THE IGNITION SWITCH IS ON.
 - C. OPTIONALLY, USE THE WHITE WIRE FOR ENGINE FAST/SLOW (12VDC MAINTAINED-FM ONLY).
 - D. OPTIONALLY, USE THE BLUE WIRE FOR ENGINE START.
 - E. OPTIONALLY, USE THE ORANGE WIRE FOR ENGINE STOP.
 - F. OPTIONALLY, USE THE GREEN WIRE FOR AUXILIARY (12VDC MAINTAINED-FM ONLY).

NOTE: ALL ELECTRICAL CONNECTIONS BETWEEN THE CRANE AND THE VEHICLE SHOULD BE MADE USING RELAYS TO ISOLATE THE ELECTRICAL SYSTEMS OF EACH AS MUCH AS POSSIBLE.

WARNING! FAILURE TO CORRECTLY PLUMB AND WIRE CRANE CAN CAUSE INADVERTENT OPERATION AND DAMAGE TO CRANE AND/OR PERSONNEL!

11. Once crane and plumbing are installed on the truck, fill the reservoir to top of sight glass (mobile DTE 13 or equal). Before operating crane, connect together the pressure and return hoses going to base of crane using 10-12 JIC union and engage PTO with engine running. Allow oil to circulate for 15 to 20 minutes. This will flush contaminants from the system back to the return line filter. Operate all cylinders to full extension and retraction a minimum of six times, to bleed air from system. Return all cylinders to the stored position and disengage PTO. Refill reservoir to top sight glass. To ensure 15 gallons per minute (GPM), install an in-line flow meter between the crane and the reservoir in the return hose.
12. Load test the crane to ensure proper functioning and truck stability.
13. Make certain the owner's manual is delivered to the customer.
14. For additional help: call the service department at the Auto Crane Company (918) 836-0463 (Tulsa, Oklahoma).

WARNING

FEDERAL LAW (49 CFR PART 571) REQUIRES THAT THE FINAL STAGE MANUFACTURER OF A VEHICLE CERTIFY THAT HE VEHICLE COMPLIES WITH ALL APPLICABLE FEDERAL REGULATIONS. ANY MODIFICATIONS PERFORMED ON THE VEHICLE PRIOR TO THE FINAL STAGE ARE ALSO CONSIDERED INTERMEDIATE STAGE MANUFACTURING AND MUST BE CERTIFIED AS TO COMPLIANCE. THE INSTALLER OF THIS CRANE AND BODY IS CONSIDERED ONE OF THE MANUFACTURERS OF THE VEHICLE. AS SUCH A MANUFACTURER, THE INSTALLER IS RESPONSIBLE FOR COMPLIANCE WITH ALL APPLICABLE FEDERAL AND STATE REGULATIONS, AND IS REQUIRED TO CERTIFY THAT THE VEHICLE IS IN COMPLIANCE.

IT IS THE FURTHER RESPONSIBILITY OF THE INSTALLER OF THE CRANE TO COMPLY WITH THE **OSHA** TRUCK CRANE STABILITY REQUIREMENTS AS SPECIFIED BY 29 CFR PART 1910.180 (C) (1).

10006H GENERAL ASSEMBLY P/N 460178XXX

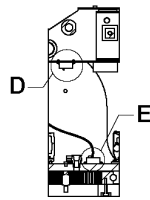
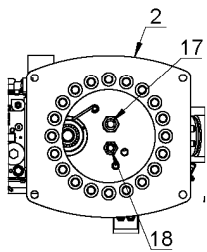
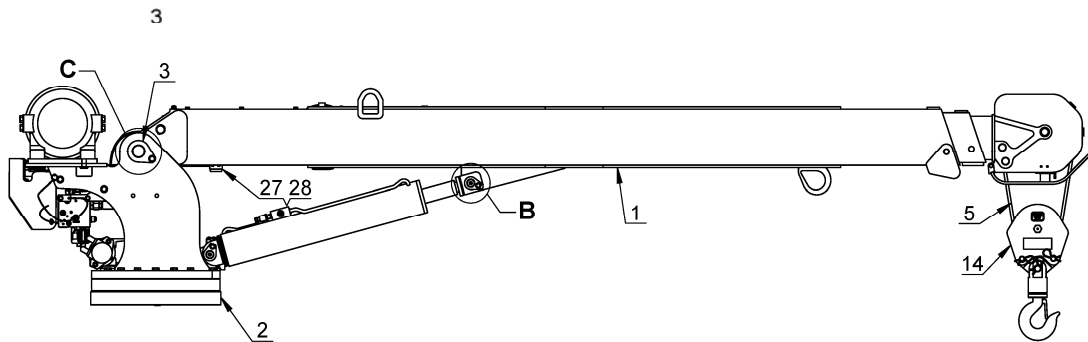
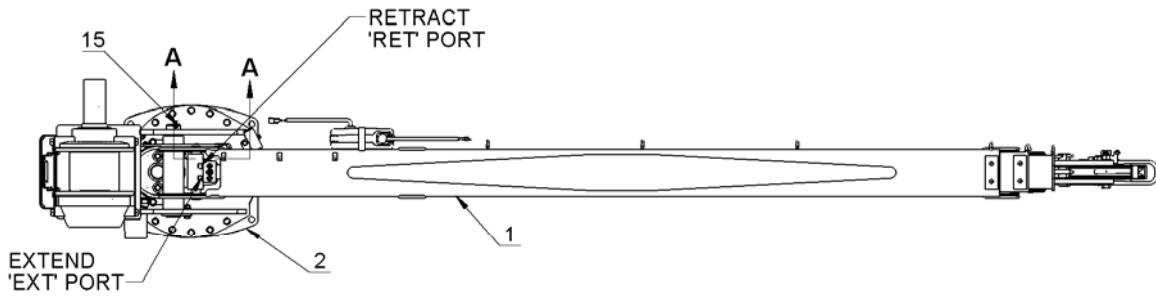

SECTION A-A

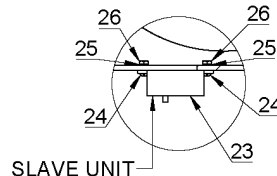

DETAIL D

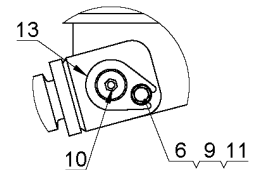

DETAIL B

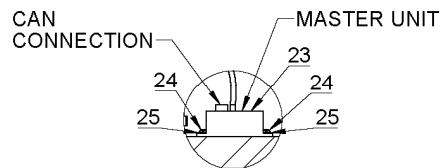

DETAIL E

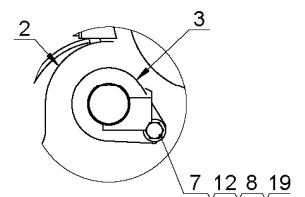

DETAIL C

NOTES:

APPLY LOCTITE 242 TO THREADS BEFORE INSTALLAITON

10006H GENERAL ASSEMBLY

ITEM NO.	NEXSTAR I-001	NEXSTAR II-000	PART NUMBER	DESCRIPTION
1	1	1	460178100	BOOM ASSEMBLY, 10006 W/LIGHT
2	1	0	460178201	PEDESTAL ASS'Y, 10006H NEXSTAR I
2	0	1	460178200	PEDESTAL ASS'Y, 10006H NEXSTAR II
3	1	1	460177020	PIN, 2 IN OD, 13.25 IN GRIP, BOOM PIVOT
4	1	1	460178021	DECAL LAYOUT/KIT 10006H
5	1	1	460090000	WIRE ROPE ASSY
6	1	1	870200000	SCREW HX HD 3/8-16UNC X 1 1/4 LG GR5
7	1	1	738642000	SCREW HX HD 1/2-13UNC X 1 3/4 LG GR8
8	1	1	21500000	WASHER, SP LK 1/2
9	1	1	21100000	WASHER SP LK 3/8
10	1	1	239300000	ZERK, GREASE
11	1	1	320976000	WASHER, FLAT, 3/8 SAE HARDENED
12	1	1	216000000	WASHER FL 1/2
13	1	1	360676000	PIN, CYLINDER
14	1	1	460125000	TRAVELING BLOCK ASSEMBLY
15	1	1	360677000	PIN, 1/4 COTTERLESS RING
16	1	1	360678000	PIN, 3/16 COTTERLESS RING
17	1	1	750419000	CAP, 12 JIC
18	1	1	367238000	CAP, 10 JIC
19	1	1	177010000	NUT HX 1/2-13UNC
20	1	1	470076000	PIN, 1 DIA 4-11/16 LG
21	1	1	360124000	PIN HITCH
22	1	1	460178023	SHIP KIT, 10006H, NEXSTAR
23	1	1	366823254	SENSOR, TRI-AXIS
24	1	4	130200000	SCREW RD HD #8-32UNC X 7/8 LG
25	1	4	197000000	WASHER SP LK #8
26	1	2	155000000	NUT HX #8-32UNC CP
27	0	1	366823236	OVERLOAD LIGHT ASSEMBLY
28	0	1	290200000	SCREW SOC HD 1/4 UNC X 1/2 GR 8
29	0	2	772043000	ZIP TIE STRAP, 12 IN NYLON BLACK

10006H PEDESTAL ASSEMBLY NEXSTAR—P/N 460178XXX

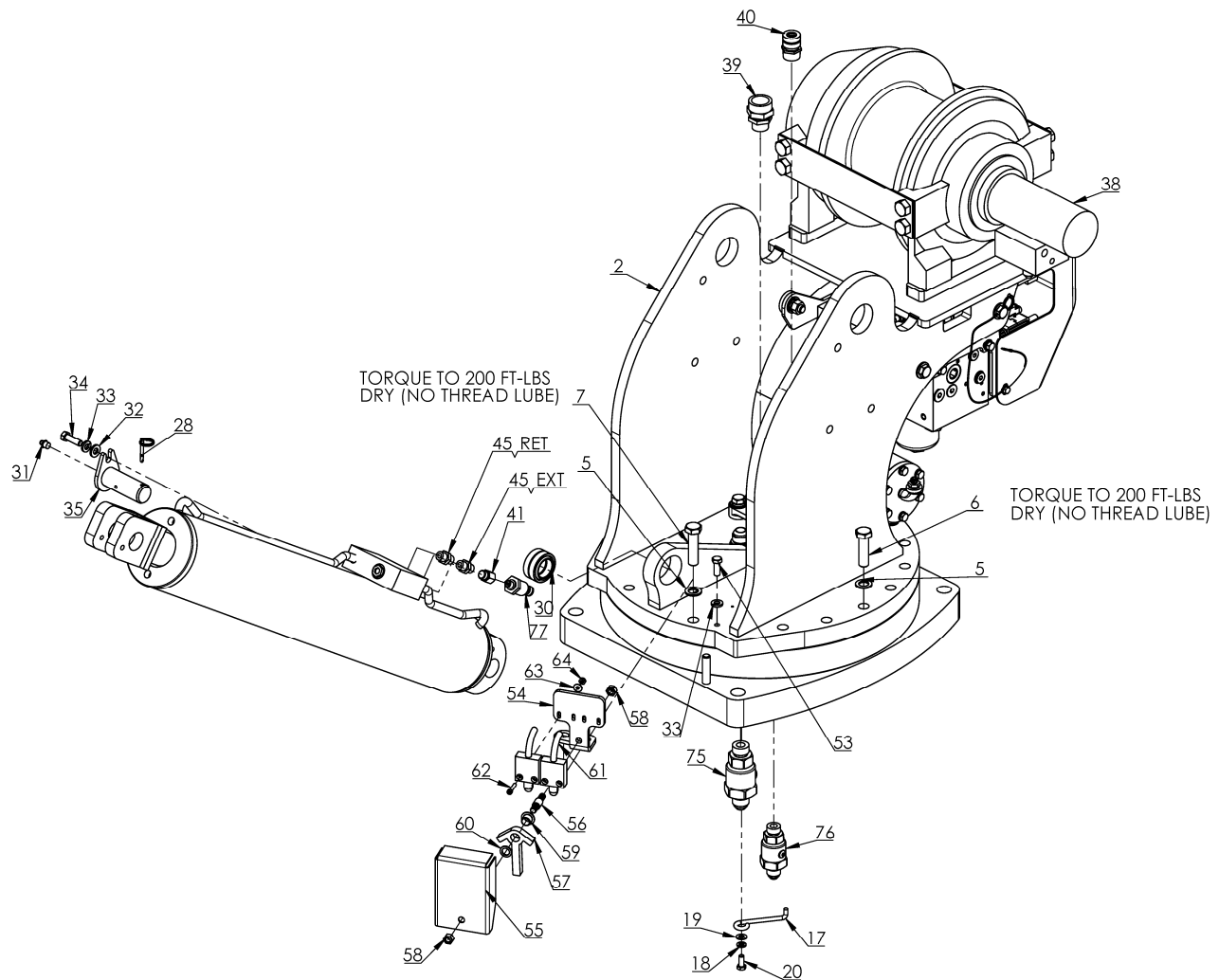

HYDRAULICS:

- “HD” PORT: HOIST DOWN
- “HU” PORT: HOIST UP
- “CW” PORT: ROTATION CW
- “CCW” PORT: ROTATION CCW
- “BU” PORT: LIFT CYL EXTEND
- “BD” PORT: LIFT CYL RETRACT
- “EXT” PORT: EXT CYL EXTEND

“RET” PORT: EXT CYL RETRACT CYLINDER SEAL

KIT: 366822251

COUNTER BALANCE CARTRIDGE: 480188000

10006H PEDESTAL ASSEMBLY

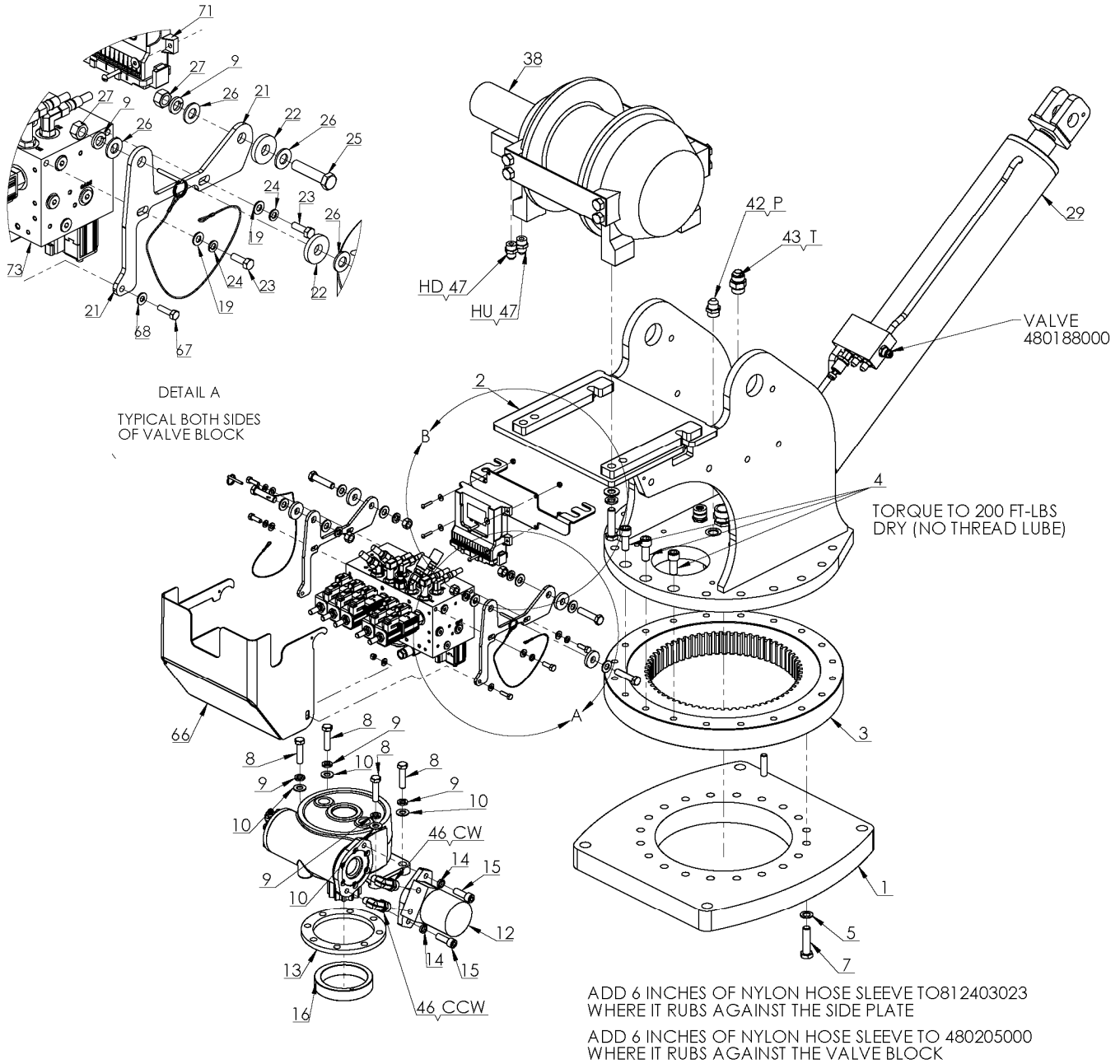

DETAIL A
TYPICAL BOTH SIDES
OF VALVE BLOCK

DETAIL B

ADD 6 INCHES OF NYLON HOSE SLEEVE TO 812403023
 WHERE IT RUBS AGAINST THE SIDE PLATE
 ADD 6 INCHES OF NYLON HOSE SLEEVE TO 480205000
 WHERE IT RUBS AGAINST THE VALVE BLOCK

10006H PEDESTAL ASSEMBLY 460178XXX

ITEM NO.	NEXSTAR I	NEXSTAR II	PART NUMBER	DESCRIPTION
1	1	1	460177220	BASE WELDMENT, 10006
2	1	1	460177210	PEDESTAL WELDMENT, 10006
3	1	1	372064000	ROTATION BEARING
4	3	3	460098000	SCREW SOC HD 5/8-11UNC X 1 1/2 LG GR8
5	34	34	23902000	WASHER FL 5/8 HARDENED
6	13	13	490171000	SCREW HX HD 5/8UNC X 2 1/4 GR 8
7	27	27	368121000	SCREW HX HD 5/8UNC X 2-1/2 CP GR8
8	4	4	11608000	SCREW HX HD 1/2UNC X 2 GR5
9	8	8	21500000	WASHER, SP LK 1/2
10	4	4	320588000	WASHER, FL 1/2, HARDENED
11	1	1	160414000	ROTATION GEARBOX, SLEW DRIVE
12	1	1	366440000	ROTATION MOTOR
13	1	1	480011000	SEAL ROTATION BOX
14	2	2	215020000	WASHER SP LK 1/2 HI COLLAR
15	2	2	12197000	SCREW SOC HD 1/2-13UNC X 1/2 LG
16	1	1	360162000	RING, ECCENTRIC
17	1	1	360207000	RETAINER ECCENTRIC RING
18	1	1	206010000	WASHER SP LK 5/16
19	5	5	209010000	WASHER FL 5/16
20	1	1	330252000	SCREW HX HD 5/16UNC X 3/4 ZP GR5
21	2	2	460178210	BRACKET, VALVE MTG 10006H
22	4	4	366823211	SPACER, VALVE BANK
23	4	4	781100000	SCREW HX HD 5/16-18UNC X 1 LG GR5
24	4	4	206000000	WASHER 5/16 LOCK SS
25	4	4	366391000	SCREW HX HD 1/2UNC X 2 1/4 ZP GR 5
26	8	8	216000000	WASHER FL 1/2

10006H PEDESTAL ASSEMBLY 460178XXX

ITEM NO.	NEXSTAR I	NEXSTAR II	PART NUMBER	DESCRIPTION
27	4	4	177010000	NUT HX 1/2-13UNC
28	1	1	360678000	PIN, 3/16 COTTERLESS RING
29	1	1	460177240	CYLINDER, LIFT
30	1	1	366333000	BEARING, SPHERICAL 1.25 ID
31	1	1	239300000	ZERK, GREASE
32	1	1	320976000	WASHER, FLAT, 3/8 SAE HARDENED
33	2	2	211000000	WASHER SP LK 3/8
34	1	1	870200000	SCREW HX HD 3/8-16UNC X 1 1/4 LG GR5
35	1	1	360676000	PIN, CYLINDER
36	6	6	238000000	WASHER SP LK 5/8
37	6	6	407314000	WASHER FL 5/8 X 1 5/16 OD HARDENED
38	1	1	123428000	HOIST, RPH 5000
39	1	1	366508000	CORD GRIP HUBBLE F-3 SHC 1036
40	1	1	366698000	CORD GRIP .375-.500 3/4" HUB
41	1	1	369611000	ADAPTER, STR -6 ORM/ -4 ORF
42	1	1	490199000	FITTING STR 10-SAE/10-JIC
43	1	1	750420000	FITTING, STR 12 SAE ORB - 12 JIC
44	1	1	812503023	HOSE ASSY, -12 HOSE, -12JICF/-12JICF, 23" LG
45	1	1	813015000	KIT, HOSE, 10006H, FOR 46017800X
46	1	1	812403019	HOSE ASSY 10 JIC STR
47	2	2	200876000	FITTING 6 SAE/6 JIC STRAIGHT
48	2	2	490198000	FITTING 10SAE(M)/6JIC ELBOW 90
49	2	2	372041000	FITTING 8JIC/10SAE STRAIGHT 8-10 F5OX
50	2	2	480203000	HOSE ASSY 8 STR X 24.75
51	2	2	812203022	HOSE ASSY, -6 JIC FEM, STR
52	2	2	812203038	HOSE ASSY 6 STR

10006H PEDESTAL ASSEMBLY 460178XXX

ITEM NO.	NEXSTAR I	NEXSTAR II	PART NUMBER	DESCRIPTION
53	2	2	480205000	HOSE ASSY 6 STR X 19.25
54	1	1	374086000	NYLON HOSE SLEEVE
55	1	1	330371000	SCREW HX HD 3/8UNC X 1 GR8
56	1	1	460177251	PLATE, ROTATION STOP
57	1	1	366676000	COVER, ROTATION STOP
58	1	1	366673000	PIN, ROTATION STOP
59	1	1	366671000	ARM, ROTATION STOP
60	2	2	173010000	NUT HX NYLK 3/8-16UNC CP
61	1	1	460079000	BEARING, ROTATION STOP
62	1	1	366675000	WASHER, NYLON
63	1	1	460110000	ROTATION STOP SWITCH ASSEMBLY
64	1	1	460094000	SCREW, SOC HD, #10-24 X 1"L, ZPL
65	5	5	200000000	WASHER FL #10 ZP
66	5	5	158010000	NUT HX NYLK #10-24UNC ZP
67	2	2	366823240	PIN, 3/16 W/LANYARD
68	1	1	460178025	COVER, VALVE REAR MTD FM 10006H
69	2	2	560400000	SCREW HX HD 1/4-20UNC X 1 LG
70	4	4	204000000	WASHER FL SAE 1/4
71	2	2	163000000	NUT HX NYLK 1/4-20UNC
72	1	1	460178212	BRACKET, RECEIVER MTG, 10006H
73	1	1	366823252	RECEIVER, PROPORTIONAL W/LCD
74	4	4	460093000	SCREW RD HD SL #10-24UNC X 1 LG ZP
75	1	1	480989251	VALVE BANK, 15 GPM W/FILTER SENSOR
75	1	0	480989261	VALVE BANK, 15 GPM
76	1	1	480989250	KIT, ELEC/HYD 8406H-1 4005H NEXSTAR II
76	1	0	480989260	KIT, ELEC/HYD 8406H-1 4005H NEXSTAR I
77	1	1	460086000	FITTING, -12 SAE / -12 JIC, SWIVEL, STR
78	1	1	366358000	FITTING, -10 SAE / -10 JIC, SWIVEL, STR
79	1	1	366823255	TRANSDUCER, PRESSURE 0-3000 PSI
80	1	1	460178253	TAG, ID 10006H
81	1	1	366823257	HARNESS, 5005H-1 4005H FULLY PROP

NOTES

10006H BOOM ASSEMBLY

P/N: 460178100

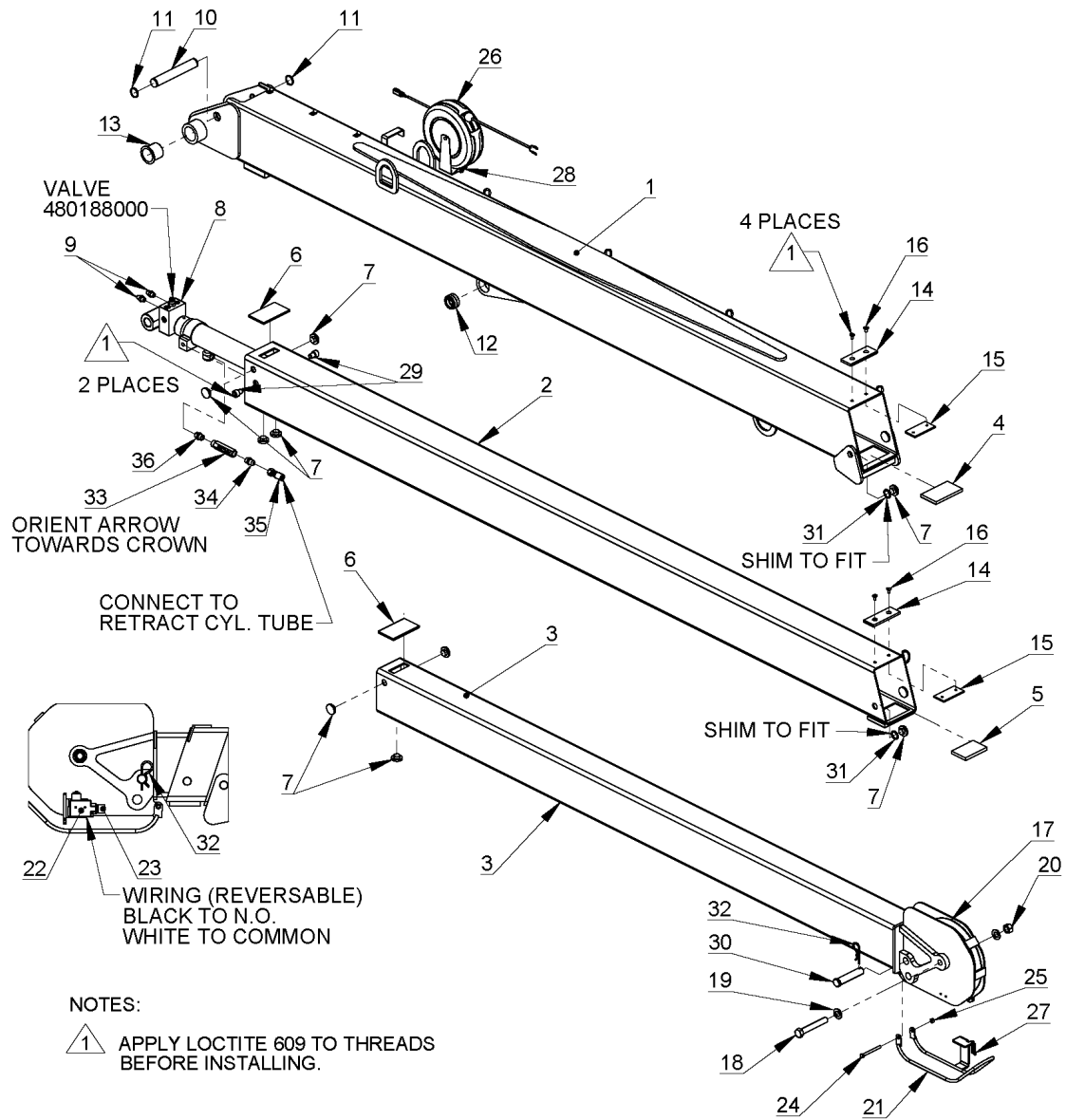

CYL SEAL KIT P/N: 480988151
C'BAL P/N: 360153001

10006H BOOM ASSEMBLY

P/N: 460178100

ITEM NO.	QTY.	PART NO.	DESCRIPTION
1	1	460178110	LOWER BOOM WELDMENT 10006H W/LIGHT MTG
2	1	460177120	MID BOOM WELDMENT, 10006H
3	1	460177130	UPPER BOOM WELDMENT, 10006
4	1	460052000	WEAR PAD, BOTTOM MID
5	1	460053000	WEAR PAD, BOTTOM UPPER
6	2	460177160	WEAR PAD, 5.13X3X.25, BOSS 1X3, 10006H
7	11	360767000	PAD BOOM 1.5 O.D.
8	1	460177150	EXTENSION CYLINDER, 2.75/2.50 BORE, 10006H
9	2	200876000	FITTING STR 6 SAE/6 JIC
10	1	460177161	PIN, 1.25OD, 7.81 GRIP, RING GROOVE BOTH ENDS
11	2	480029000	RING, RETAINING A
12	1	366333000	BEARING SPHERICAL 1.25 ID
13	2	366394000	BEARING PIVOT
14	2	460081000	WEAR PAD, CABLE
15	2	460082000	PLATE, WEAR PAD RETAINER
16	4	460177163	SCREW SOC HD CTRSINK 5/16UNF X 5/8 LONG ZP
17	1	466130000	SHEAVE ASSY 7/16 ROPE B
18	1	144000000	SCREW HX HD 3/4UNF X 5 GR5
19	2	221020000	WASHER FL 3/4 CP
20	1	186000000	NUT HX NYLK 3/4-16UNF CP
21	1	360718000	BAIL WELDMENT
22	1	646900000	SWITCH-BZ-E6-2RN 6469
23	1	642918000	CORD CONNECTOR CABLE SIZE .250-.312 A
24	1	780300000	SCREW HX HD 5/16UNC X 3-1/2 CP GR 5
25	1	168010000	NUT HX NYLK 5/16-18UNC CP
26	1	360759001	CORD REEL ASSY
27	1	366678000	SPRING, RETURN
28	1	360882000	NUT, PUSH-ON TYPE (.161-.164 DIA)
29	2	460177162	SCREW SOC HD 5/8UNC X 3/4 LONG ZP
30	1	470076000	PIN, 1 DIA X 4-11/16LG
31	4	460177164	SHIM, 1.31 OD X 0.9 ID X 0.03 TH, NYLON
32	1	360124000	HITCH PIN (HAIR PIN) A
33	1	460177180	VALVE, IN-LINE RELIEF, 400 PSI
34	1	770055000	FITTING STR 8 SAE/8 JIC
35	1	812234017	HOSE ASSY, -8 JIC/-8 JIC, -6 HOSE, 17LG
36	1	374400000	FITTING, -8 ORB/-8 ORB, STRAIGHT

10006H ROTATION GEARBOX P/N: 160414

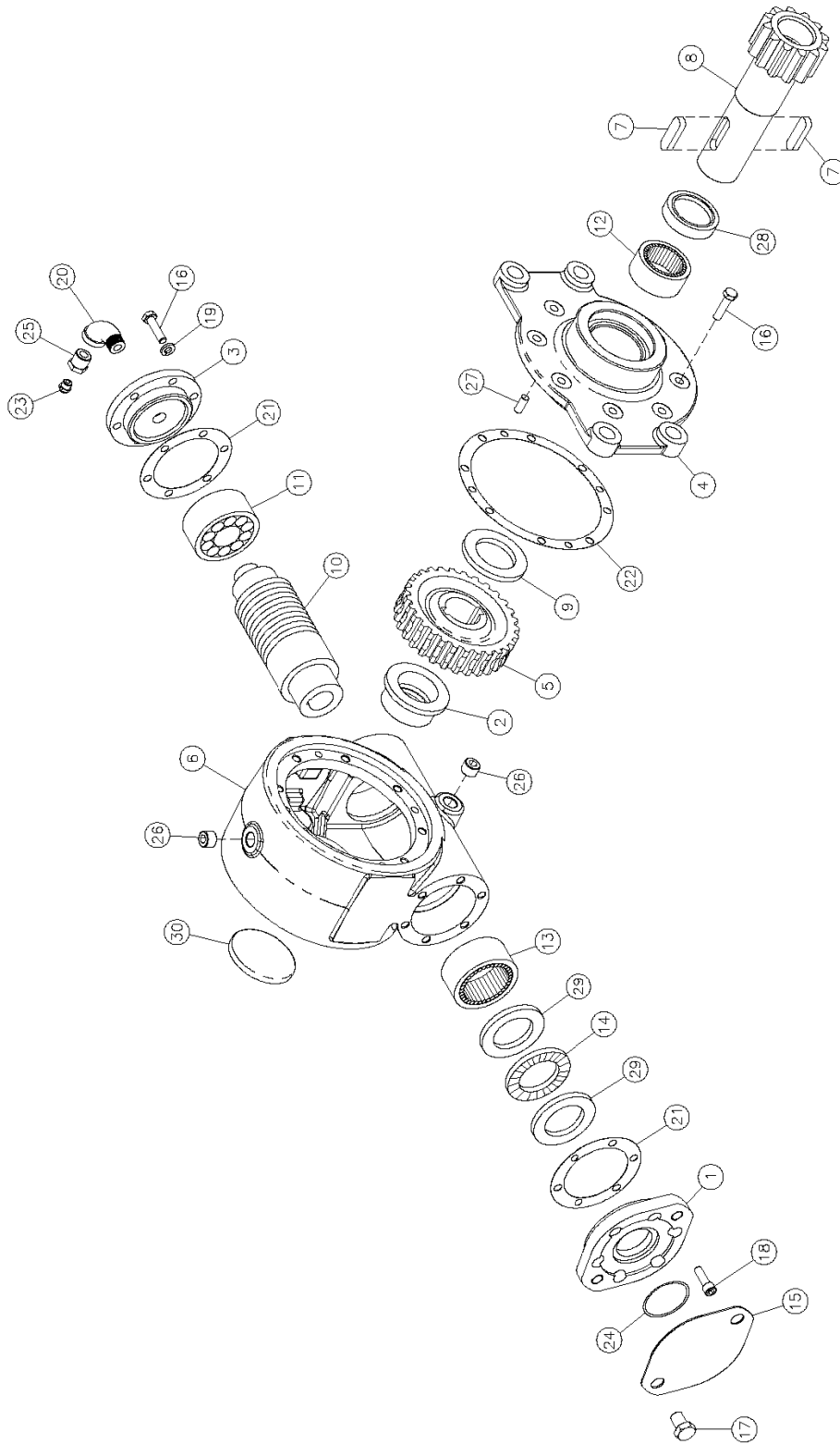

10006H ROTATION GEARBOX

P/N: 160414

Item NO.	QTY.	PART NO.	DESCRIPTION
1	1	300058	ADAPTER
2	1	308085	BUSHING
3	1	316092	CAP-BEARING
4	1	328165	COVER
5	1	334016	GEAR-RH
6	1	338261	HOUSING-GEAR
7	2	342120	KEY-RD ENDS
8	1	357139	SHAFT-OUTPUT
9	1	366019	WASHER-THRUST
10	1	368183	WORM-RH
11	1	402044	BEARING-BALL
12	1	402105	BEARING-NEEDLE
13	1	402106	BEARING-NEEDLE
14	1	402107	BEARING-THRUST
15	1	413013	COVER
16	14	414143	CS-5/16-18NCX1-1/4,HXHD GR5,N/HVY/P
17	2	414581	CAPSCREW-1/2-13NCX3/4LG,HXHD,Z/P,G5
18	6	414869	SCREW-5/16-18NC X1LG,HXSOC,ND STRIP
19	6	418163	LOCKWASHER-5/16 MED SECT,ZINC PLATE
20	1	432011	ELBOW-90DEG
21	2	442182	GASKET
22	1	442187	GASKET
23	1	456008	RELIEF FITTING
24	1	462029	O-RING,1 5/8 ID X 2 OD X 3/16 THK
25	1	468002	RED-3/8-1/8NPTF GEN.PLUG
26	2	468018	PIPE PLUG
27	4	470062	DOWEL PIN
28	1	486071	SEAL-OIL
29	2	518026	THRUST WASHER
30	1	530101	PLUG-EXPANSION

10006H HOIST ASSEMBLY

P/N: 123428

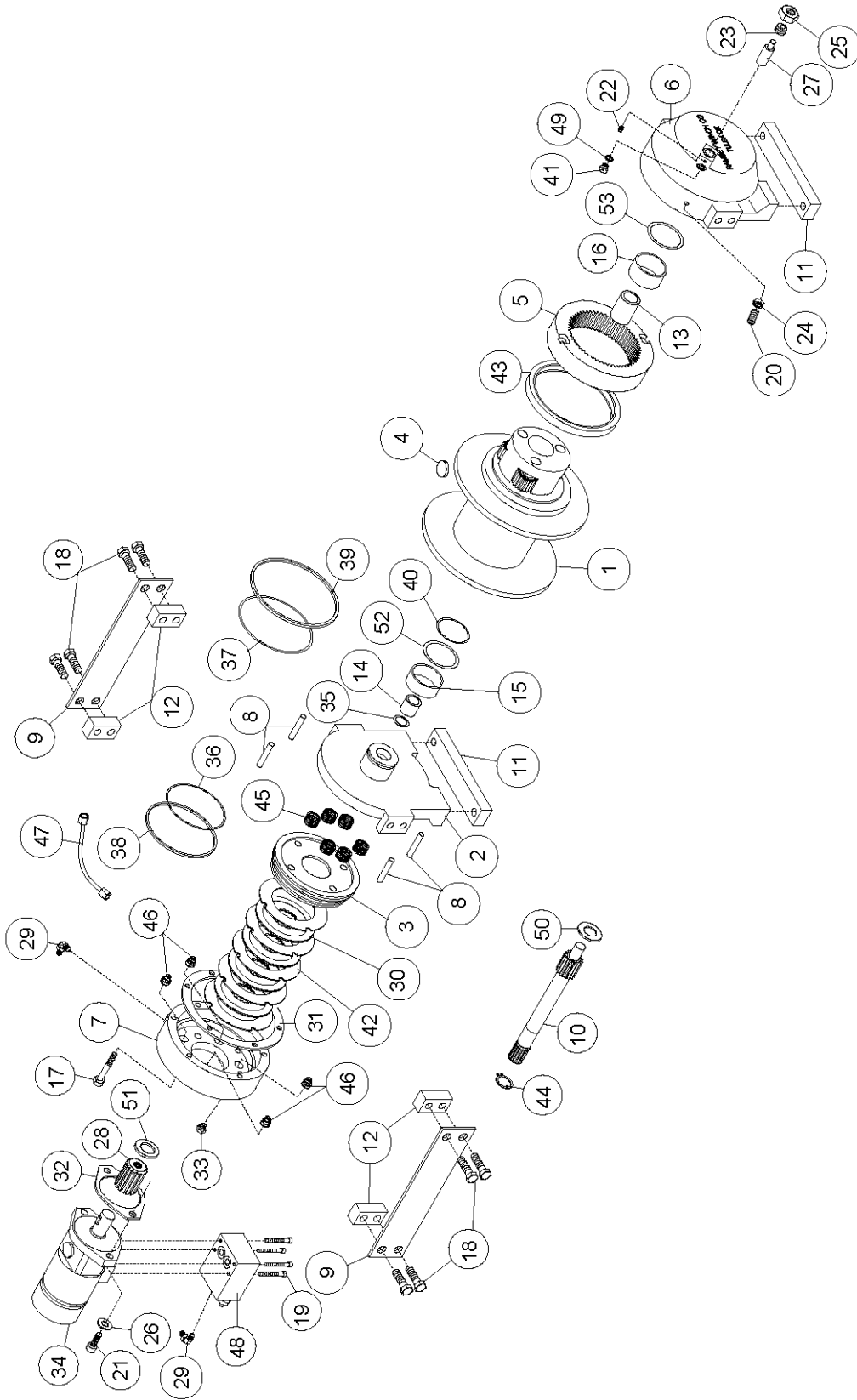

10006H HOIST ASSEMBLY

P/N: 123428

ITEM NO.	QTY.	PART NO.	DESCRIPTION
1	1	234195	ASSEMBLY-DRUM, RPH 5000, SHORT DRUM
2	1	296611	ASSEMBLY-MOTOR END BEARING, RPH 5000
3	1	306042	PISTON-BRAKE, RPH-12000
4	1	315004	ANCHOR-CABLE, RPH 3000 A/C WINCH
5	1	334177	GEAR-RING, DUCTILE IRON, RPH-15000
6	1	338297	END BEARING,GEAR HOUSING RPH-15000 DUCTILE
7	1	338302	HOUSING-BRAKE, RPH 12000
8	4	346045	PIN-BRAKE, RPH 12, .375 DIA X 2.125 LG
9	2	350704	PLATE-TIE, RPH 5000 AUTO CRANE
10	1	357517	SHAFT-INPUT, RPH 5000 AUTO CRANE
11	2	362287	SPACER-FOOT, RPH 5000 AUTO CRANE
12	4	362288	SPACER-TIE PLATE, RPH 5000 AUTO CRANE
13	1	402120	BEARING-GARLOCK BRG. #12U16 OR EQUIVALENT
14	1	402121	BEARING-RPH 12, GARLOCK BRG. # 16DU08/EQ
15	1	412095	BUSHING-MOTOR END, BUNTING #AA3005-7
16	1	412096	BUSHING-GEAR HOUSING BUNTING #AA2703-1
17	1	414088	SCREW HX HD 5/16-18UNC x 2.75 LG, NYLK GR5 ZK
18	6	414303	SCREW HX HD 3/8-16UNC x 2 1/2 GR5 ZP
19	8	414658	SCREW HX HD 5/8-11UNC x 1 1/2 LG GR5 ZP
20	1	414926	SCREW SOC, 3/8-16UNC x 1, NYLON
21	2	414952	SCREW SOC, 1/2-13UNC x 1 1/2 LG ZP
22	1	416016	SCREW SOC, 1/4-20UNC x 1/4 LG CUP
23	1	416080	SCREW SOC, 5/8-18UNF x 1 LG CUP
24	1	418036	NUT 3/8-16UNC, HX JAM, Z/P
25	1	418088	NUT-JAM 5/8-18UNF HX HD Z/P
26	2	418218	WASHER LK 1/2 ID ZP
27	1	426048	PLUNGER-CLUTCH, BLOCKED, RPH 12/15000
28	1	431015	COUPLING-MOTOR, P/M, RPG 12000
29	2	432018	FITTING PARKER #4-C5OX-S T-LOK, 7/16-20 90 DEG
30	4	438022	DISC-BRAKE, RPH 12000, .071 1035CR STL
31	1	442220	GASKET-BRAKE HOUSING, RPH 12000, #VCN-60
32	1	442223	GASKET-MOTOR FLANGE, RPH 12000
33	1	456038	FITTING-VENT, BREATHER, #ASP-1BV/EQUIV
34	1	458121	MOTOR-HYDRAULIC
35	1	462056	O-RING-AS-568-214
36	1	462057	O-RING-AS-568-256
37	1	462058	O-RING-AS-568-259
38	1	462059	RING-BACK-UP, VERCO #1750-256
39	1	462060	RING-BACK-UP, VERCO #1750-259
40	1	462061	O-RING-AS-568-228, 2.50 O.D.

10006H HOIST ASSEMBLY

P/N: 123428

ITEM NO.	QTY.	PART NO.	DESCRIPTION
41	1	472052	PLUG-SAE O-RING, .562-18 UNF, HX SOCKET
42	5	474111	PLATE-SEPERATOR, BRAKE, RPH 12000
43	1	486081	SEAL-GEAR HOUSING, MIKRON #PWH-975
44	1	490037	SNAP RING-TRUARC #5100-93 OR EQUIVALENT
45	6	494110	SPRING-BRAKE, ASSOC #CV1000-1000-158
46	4	494112	SPRING-RPH 12000, PRESSURE TO BRAKE
47	1	509126	TUBE-HYDRAULIC BRAKE RELEASE, RPH 5000
48	1	516040	VALVE-MOTOR CONTROL
49	1	518037	THRUST WASHER-TORRINGTON #TRA-1018
50	1	518047	THRUST WASHER-.063 THK x 1.50 OD
51	1	518052	THRUST WASHER-1.37 OD, RPG 12000
52	1	518053	THRUST WASHER-BUNTING #CC 3701 01
53	1	518054	THRUST WASHER-GEAR HOUSING END,

10006H TRAVELING BLOCK ASSEMBLY

P/N: 460125000

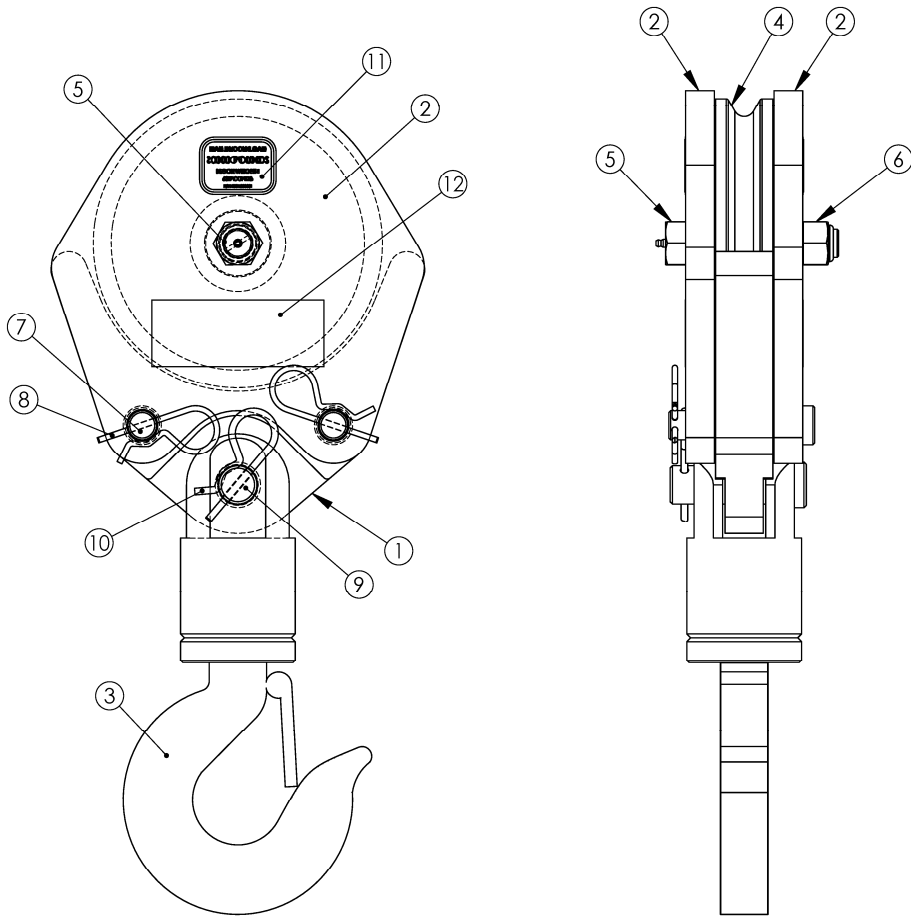

ITEM NO.	QTY	PART NUMBER	DESCRIPTION
1	1	460127000	TACKLE LOWER
2	2	460126000	SIDE PLATE TRAVELING BLOCK
3	1	480366000	HOOK SWIVEL 6 METRIC TON
4	1	490256000	SHEAVE ASSY 7/16 ROPE
5	1	490313000	BOLT, SHEAVE W/ZERK FITTING
6	1	186000000	NUT HX NYLK 3/4-16UNF CP
7	2	360605000	PIN, BLOCK
8	2	366813000	PIN HITCH
9	1	480368000	PIN SWIVEL HOOK
10	1	360124000	PIN HITCH
11	2	460128000	DECAL MAX BLOCK LOAD
12	2	405180000	DECAL STAY CLEAR OF LOAD

10006H MAIN HARNESS

P/N: 366823257

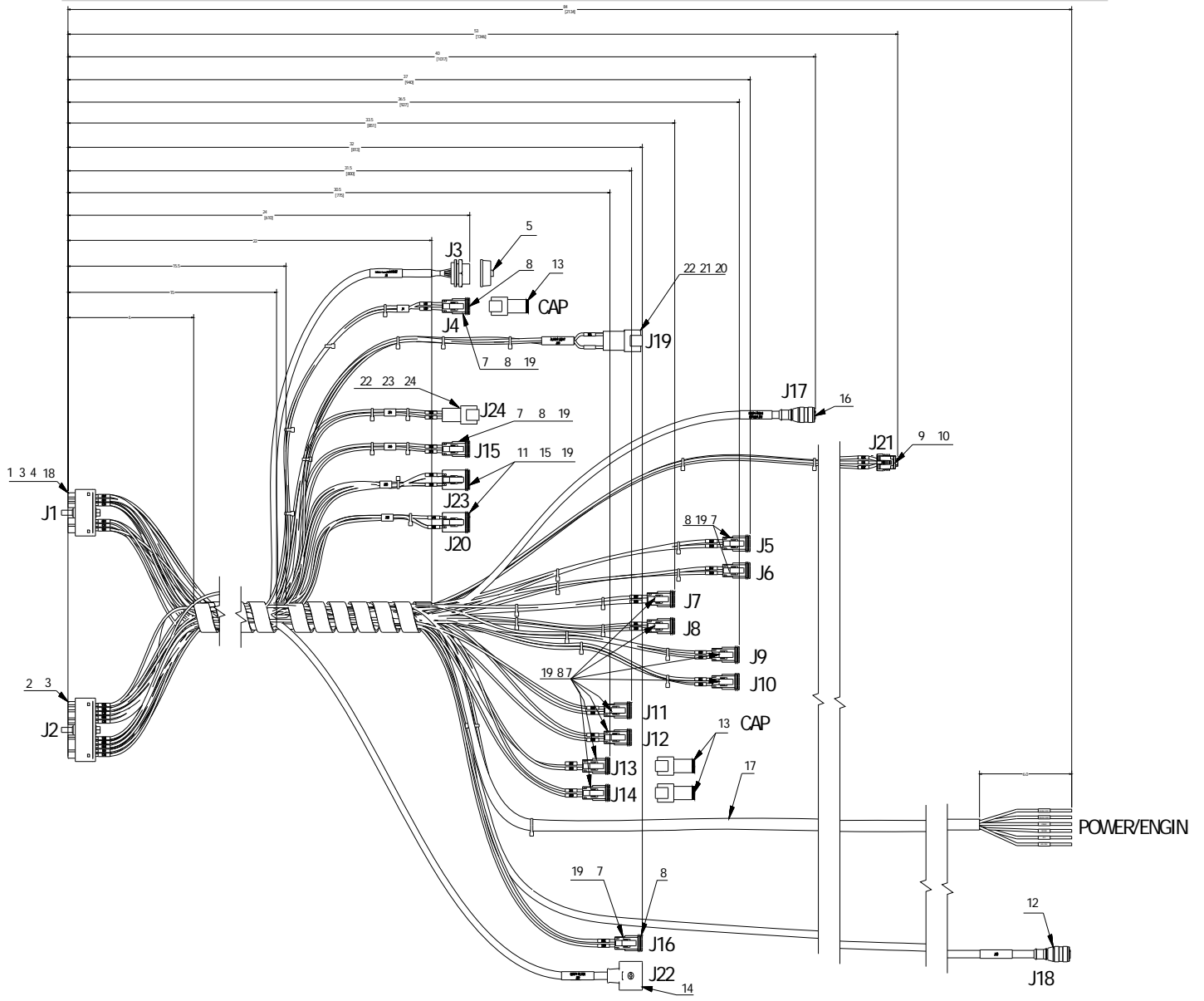

CONNECTOR ID	
CONNECTOR	DESCRIPTION
J1	RECIEVER 18 PIN CONNECTION
J2	RECIEVER 30 PIN CONNECTION
J3	USB CONNECTION
J4	CAN CONNECTOR
J5	BOOM UP
J6	BOOM DOWN
J7	SWING CW
J8	SWING CCW
J9	BOOM RETRACT
J10	BOOM EXTEND
J11	HOIST A DOWN
J12	HOIST A UP
J13	HOIST B DOWN
J14	HOIST B UP
J15	ANTI-2 BLOCK
J16	DUMP VALVE
J17	BOOM ANGLE SENSOR
J18	PENDANT CONNECTION
J19	ALARM LIGHT
J20	ADDRESS
J21	BOOM PT
J22	DIRTY FILTER
J23	SWING LIMIT SWITCHES
J24	FAST IDLE MOMENTARY

10006H MAIN HARNESS

P/N: 366823257

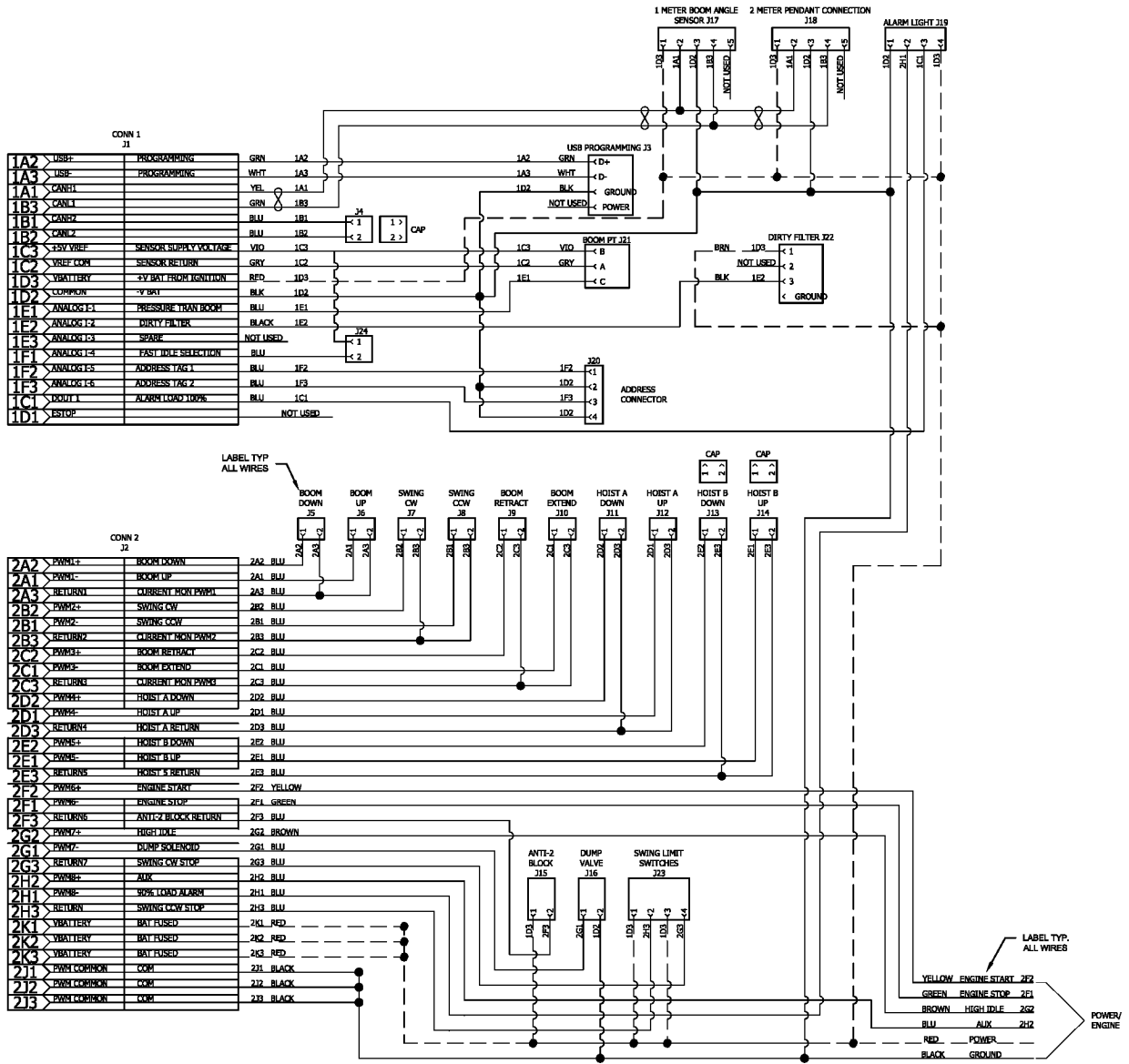

WIRING DETAIL		
CONNECTOR	FUNCTION	WIRE LENGTH
J3	USB CONNECTION	24
J4	CAN CONNECTION	24
J5	BOOM UP	37
J6	BOOM DOWN	37
J7	SWING CW	33.5
J8	SWING CCW	33.5
J9	BOOM RETRACT	36.5
J10	BOOM EXTEND	36.5
J11	HOIST A DOWN	31.5
J12	HOIST A UP	31.5
J13	HOIST B DOWN	30.5
J14	HOIST B UP	30.5
J15	ANTI-2 BLOCK	24
J16	DUMP VALVE	32
J17	BOOM ANGLE SENSOR	40
J18	PENDANT CONNECTION	84
J19	ALARM LIGHT	32
J20	ADDRESS	24
J21	BOOM PT	53
J22	DIRTY FILTER	32
J23	SWING LIMIT SWITCHES	24
J24	FAST IDLE MOMENTARY	24
PWR/ENG	POWER/ENGINE	84

**10006H HYDRAULIC CONTROL VALVE
NEXSTAR I P/N: 480989261**

ITEM NO.	QTY	PART NUMBER	DESCRIPTION
1	11	366823901	COIL, 5/8" DIA 12VDC DEUTSCH
2	3	366823902	CARTRIDGE, SIZE 4W 3P CLSD CTR
3	1	366823906	VALVE, LOGIC SPOOL TYPE 225 PSI
4	1	366823914	VALVE, CHECK 100 PSI
5	1	366823904	CARTRIDGE, 2-WAY UNLOADER
6	1	366823909	BOWL, FILTER
7	2	366823903	CARTRIDGE, SIZE 4W 3P FLOAT CTR
8	1	366823905	VALVE, RELIEF DIRECT-ACTING (2750PSI)
9	2	480195000	FITTING 45 6-SAE/6-JIC
10	2	241175000	FITTING 90 6-SAE/6-JIC
11	2	330645000	FITTING 90 6-SAE/6-JIC LONG
12	2	374017000	FITTING 45 8-SAE/8-JIC
13	1	490199000	FITTING STR 10-SAE/10-JIC
14	1	366823910	FILTER, 20 MICRON
15	1	750420000	FITTING, STR 12 SAE ORB - 12 JIC

10006H HYDRAULIC CONTROL VALVE
P/N: 480989251

ITEM NO.	QTY	PART NUMBER	DESCRIPTION
1	11	366823901	COIL, 5/8" DIA 12VDC DEUTSCH
2	3	366823902	CARTRIDGE, SIZE 4W 3P CLSD CTR
3	1	366823906	VALVE, LOGIC SPOOL TYPE 225 PSI
4	1	366823914	VALVE, CHECK 100 PSI
5	1	366823904	CARTRIDGE, 2-WAY UNLOADER
6	1	366823909	BOWL, FILTER
7	2	366823903	CARTRIDGE, SIZE 4W 3P FLOAT CTR
8	1	366823905	VALVE, RELIEF DIRECT-ACTING (2750PSI)
9	2	480195000	FITTING 45 6-SAE/6-JIC
10	2	241175000	FITTING 90 6-SAE/6-JIC
11	2	330645000	FITTING 90 6-SAE/6-JIC LONG
12	2	374017000	FITTING 45 8-SAE/8-JIC
13	1	366823913	INDICATOR, CLOGGING FILTER
14	1	490199000	FITTING STR 10-SAE/10-JIC
15	1	366823910	FILTER, 20 MICRON
16	1	750420000	FITTING, STR 12 SAE ORB - 12 JIC

10006H

COUNTERBALANCE VALVE ADJUSTMENT

Counterbalance Valve Adjustment

1. With PTO disengaged and boom properly supported, remove the plug on the counterbalance valve. Install a pressure gauge (0-3000 PSI) into the port.
2. Engage PTO and insure pump flow is 8 to 9 GPM. With no load on boom, boom up to an angle of 70 degrees. Boom down and note pressure. If pressure reading is not approximately 1300 PSI, the counterbalance valve requires adjustment.
 - A. To increase the CB valve setting, loosen nut and turn Allen head screw counter clockwise.
 - B. To reduce the CB valve setting, loosen nut and turn Allen head screw clockwise.
3. Tighten nut on adjustment screw and repeat procedure if needed to obtain the proper pressure setting.
4. Disengage PTO, remove the pressure gauge and install plug. Crane is now ready for operation.

Notice:

1. In an **EMERGENCY** situation when it becomes necessary to lower the boom without flow present, the CB valve adjustment can be turned in until the boom begins to descend. Make sure the boom will lower onto a proper support. Loosen the lock nut and carefully turn adjustment screw clockwise! Count the number of turns. *Turn slowly until the boom just begins to lower, and remove hand/arm/fingers from cranes while boom is lowering.*
2. Turning adjustment screw too far will cause valve to come apart on the inside. This condition is not repairable
3. After boom is lowered, turn adjustment screw counter clockwise the approximate number of turns made during lowering procedure. After the problem is corrected, readjust the counterbalance valve using the procedure in this manual.

WARNING:

**DO NOT TRY TO ADJUST VALVES WHILE BOOM IS MOVING.
Doing so may result in personal injury!**

10006H

VALVE OVERRIDE OPERATION

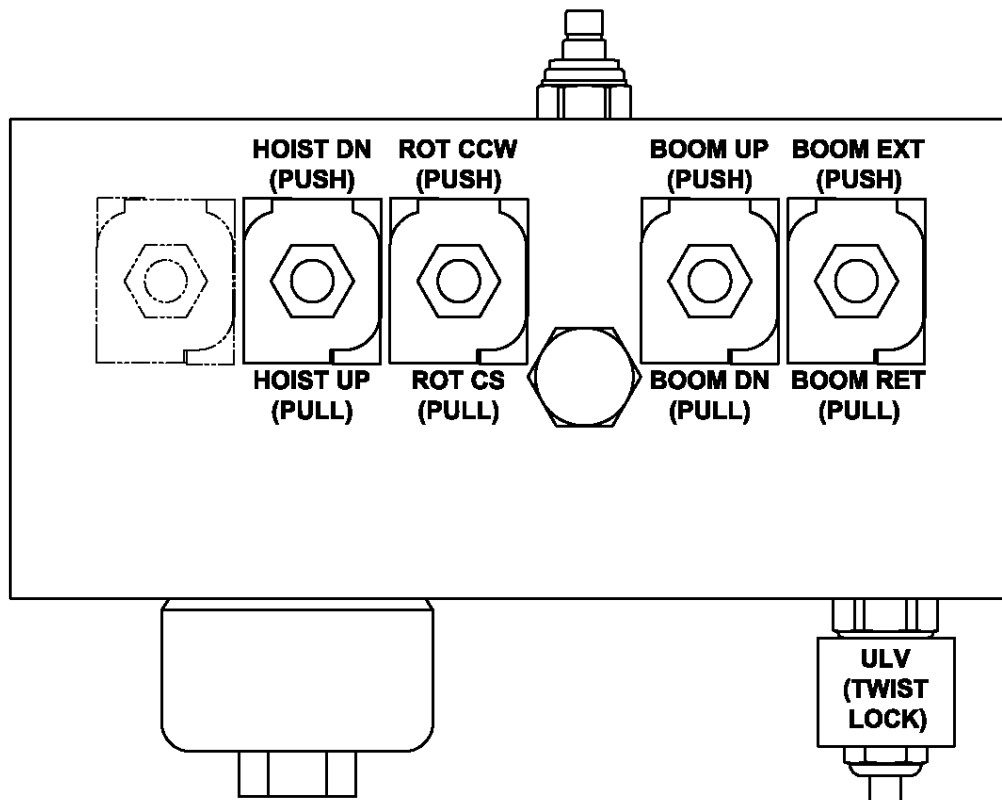

MANUAL OVERRIDE PROCEDURES

- 1) OPERATE THE TWIST LOCK END ON THE UNLOADER VALVE (ULV). THIS WILL SEND HYDRAULIC FLUID TO THE VALVE BLOCK.
- 2) SELECT THE FUNCTION DESIRED, THEN CLOSE THE GAP BETWEEN COLLAR AND THE END ON THE OVERRIDE BUTTON.
- 3) PUSH OR PULL THE OVERRIDE BUTTON FOR THE DESIRED DIRECTION OF MOVEMENT. THE FARTHER THE BUTTON IS DEPRESSED OR PULLED, THE FASTER THE FUNCTION WILL OPERATE.
- 4) WHEN MANUAL OPERATION IS COMPLETE, RETURN THE UNLOADER VALVE TWIST LOCK TO ITS ORIGINAL POSITION.

10006H TROUBLESHOOTING CHART

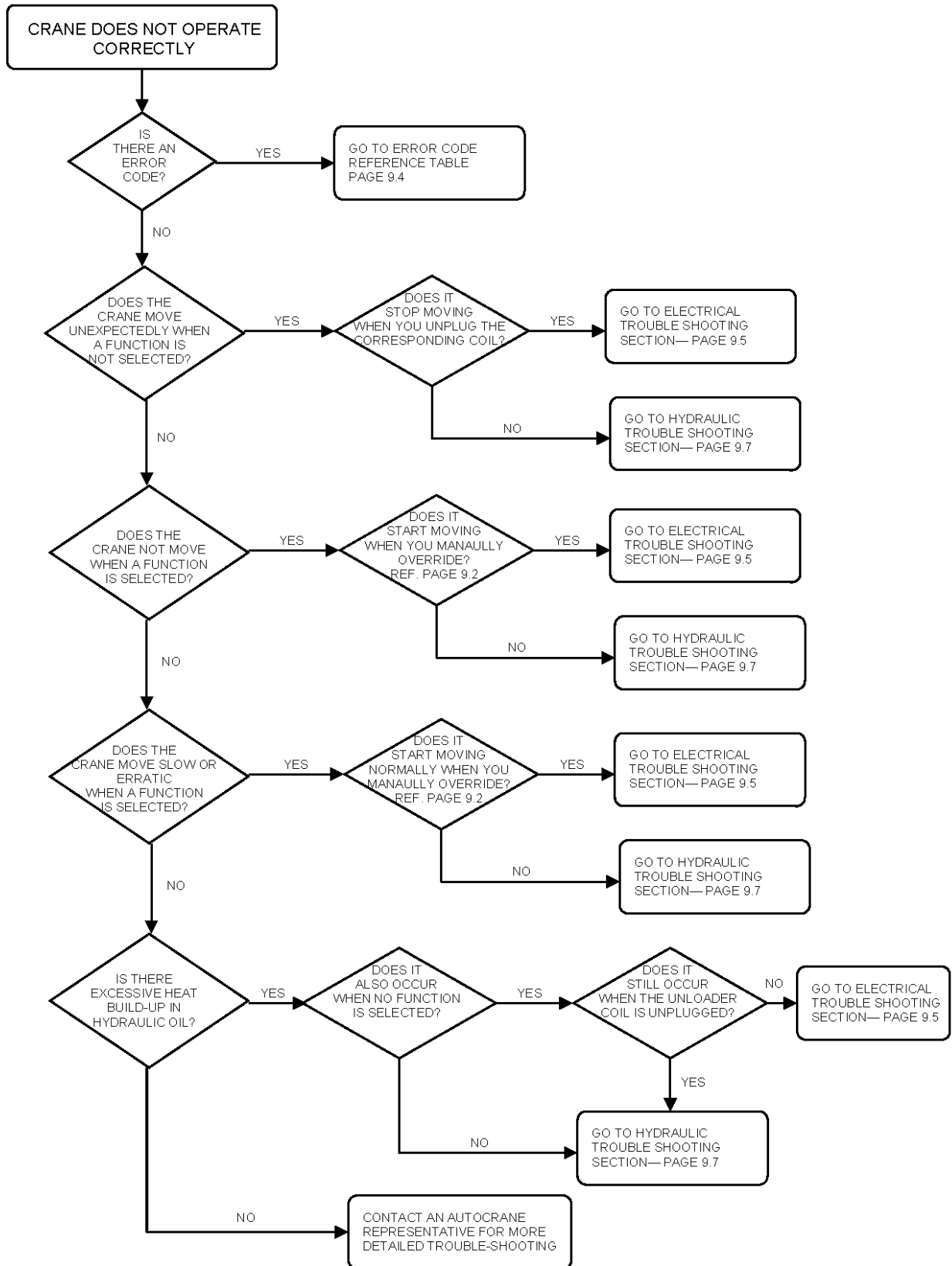

10006H

ERROR CODE TROUBLESHOOTING CHART

ERROR CODE	CAUSE	EFFECT	SOLUTION
S0. ESTOP ACTIVE	E-STOP ACTIVATED	ALL OUTPUTS WILL BE DISABLED	TURN ON TRANSMITTER. FOLLOW DE-ACTIVATING E-STOP PROCEDURES ON PAGE 3-3.0.
S1. CAN RX TO	RECEPTION OF A CAN MESSAGE TIMED OUT	ALL OUTPUTS WILL BE DISABLED	DETERMINE WHY MESSAGE(S) IS(ARE) NOT BEING RECEIVED. WHEN PROBLEM IS CORRECTED THE ALARM WILL CLEAR.
S2. TEMP OUT OF RANGE	OUTSIDE OPERATING TEMPERATURE -40C TO 85C	ALL OUTPUTS WILL BE DISABLED	GET TEMPERATURE INTO ACCEPTABLE RANGE. ALARM WILL CLEAR AFTER 1 MINUTE.
S16-S31 OUT X OVER-CURRENT ERR	WHEN THE OUTPUT WAS ACTIVATED, A CURRENT OF OVER 3.5 A WAS BEING DRAWN.	THAT OUPUT IS DISABLED	CYCLE POWER TO RECEIVER. IF PROBLEM CONTINUES, FIND WHAT CAUSED OVERCURRENT DRAW AND CYCLE POWER.
S32-S47 OUT X +VB SHORT	WHEN THE OUTPUT WAS SUPPOSED TO BE A GROUND IT HAD A POSITIVE VOLTAGE	THAT OUTPUT IS DISABLED	DETERMINE THE CAUSE OF THE SHORT, FIX THE CAUSE, AND CYCLE POWER TO RECEIVER.
S32-S47 OUT X -VB SHORT	WHEN THE OUTPUT WAS SUPPOSED TO BE A POSITIVE VOLTAGE IT HAD A GROUND	THAT OUTPUT IS DISABLED	DETERMINE THE CAUSE OF THE SHORT, FIX THE CAUSE, AND CYCLE POWER TO THE RECEIVER.
A1. BOOM PSI LOW	LIFT CYLINDER PRESSURE BELOW 50 PSI	DISABLES ALL FUNCTIONS EXCEPT BOOM UP AND HOIST DOWN	HOIST DOWN LOAD IF APPLICABLE, AND RAISE BOOM OFF ANY SUPPORTS. ALARM WILL CLEAR ONCE PRESSURE IN CYLINDER IS RESTORED.
A2. CW LIMIT	CRANE HAS REACHED THE LIMIT OF ROTATION IN THE CW DIRECTION	DISABLES CLOCKWISE ROTATION	ROTATE CCW TO CLEAR ERROR. ONCE SWITCH IS DEACTIVATED THE ALARM WILL CLEAR.
A3. CCW LIMIT	CRANE HAS REACHED THE LIMIT OF ROTATION IN THE CCW DIRECTION	DISABLES COUNTER-CLOCKWISE ROTATION	ROTATE CW TO CLEAR ERRO. ONCE SWITCH IS DEACTIVATED THE ALARM WILL CLEAR.
A4. TRK TILT WARN	TRUCK ANGLE EXCEEDS 5.7 DEGREES OR 10% SLOPE	ALL FUNCTIONS WILL ONLY OPERATE AT 50% OF SPEED	MOVE VEHICLE TO LEVEL GROUND.
A5. TRK TILT ALARM	TRUCK ANGLE EXCEEDS 8.5 DEGREES OR 15% SLOPE	ALL FUNCTIONS ARE DISABLED	MOVE VEHICLE TO LEVEL GROUND.
A6. ANTI 2-BLOCK	ANTI 2-BLOCK IS ACTIVATED. TRAVELING BLOCK HAS COME INTO CONTACT WITH BOOM	DISABLES BOOM DOWN, EXTEND, AND HOIST UP	MOVE LOAD AWAY FROM BOOM BY EITHER RETRACTING, HOISTING DOWN, OR BOOMING UP. IF THERE IS NO LOAD NEAR TIP OF BOOM CHECK FUNCTION OF THE BAIL WELDMENT. IT MUST COME INTO CONTACT WITH SWITCH PLUNGER UNDER NORMAL CONDITIONS.
A7. 90% LOAD WARN	REACHED 90% OF RATED CAPACITY	REDUCES SPEED OF ALL FUNCTIONS BY 50%	REDUCE LOAD TO CLEAR ALARM.
A8. 100% LOAD ALARM	RACHED 100% OF RATED CAPACITY	DISABLES BOOM DOWN, EXTEND, AND HOIST UP	REDUCE LOAD BY EITHER RETRACTING, BOOMING UP, OR HOISTING DOWN.
A9. SLOW ROTATE ACT	LIFT CYLINDER HAS EXCEEDED 600 PSI	REDUCES ROTATE FUNCTIONS BY 50%	THIS IS A SAFETY FEATURE THAT PREVENTS EXCESSIVE SWINGING OF HEAVY LOADS. WILL RESET WHEN LOAD DECREASES AND FUNCTION IS DEACTIVATED.
A10. BOOM SENSOR ERR	BOOM ANGLE SENSOR SIGNAL FAILED	ALL FUNCTIONS ARE REDUCED BY 50%	CHECK CONNECTIONS TO BOOM ANGLE SENSOR. VERIFY LIGHTS ARE ON AT SENSOR BASE.
A11. BOOM ANGLE RANGE	ANGLE SENSOR IS OUT OF RANGE	OPERATES NORMALLY	BOOM ANGLE SENSOR IS MOUNTED INCORRECTLY. CHECK MOUNTING. THE ARROW SHOULD BE FACING THE TIP OF THE CRANE.
A12. BOOM PT ERR	BOOM PRESSURE TRANSDUCER ERROR	ALL FUNCTIONS ARE DISABLED EXCEPT BOOM DOWN & HOIST DOWN	CHECK CONNECTIONS TO PRESSURE TRANSDUCER LOCATED ON LIFT CYLINDER. CHECK WIRING HARNESS FOR BREAKS.
A13 DIRTY FILTER	FILTER IS DIRTY IF TEMPERATURE OF OIL IS AT LEAST 100 DEG	OPERATES NORMALLY	REPLACE FILTER. PART NUMBER IS 366823910.

10006H

ELECTRICAL TROUBLESHOOTING CHART

PROBLEM	POSSIBLE CAUSE	DIAGNOSIS	SOLUTION
CRANE MOVES UNEXPECTEDLY	JAMMED TRANSMITTER BUTTON	ACTIVATE E-STOP TO SEE IF MOVEMENT STOPS	VERIFY THAT NOTHING HAD DEPRESSED THE BUTTON AT THE TIME OF MOVEMENT. IF IT WAS NOT DEPRESSED THEN REPLACE TRANSMITTER.
	SHORT IN HARNESS	UNEXPECTED MOVEMENT WOULD ONLY OCCUR WHEN MULTI-FUNCTIONING. UNPLUG COIL TO SEE IF MOVEMENT STOPS. CHECK AMPERAGE TO COIL USING MULTI-METER IN LINE WITH COIL. IT SHOULD BE NO MORE THAN 100mA.	TRACE WIRE BACK TO RECEIVER. VERIFY NO DAMAGE TO THE WIRE. CHECK CONNECTORS, THEY SHOULD BE CLEAR OF DEBRIS AND WATER.
	RECEIVER LOCKED UP	BOTTOM RIGHT CORNER IS A CIRCLE WITH AN ARROW. THIS SHOULD BE ROTATING AT ALL TIMES. WHEN THE CRANE IS TURNED ON.	IF THE ARROW STOPS ROTATING, SHUT POWER OFF TO THE CRANE. LEAVE OFF 2 MINUTES AND TURN POWER BACK ON. IF THIS PROBLEM PERSISTS CONTACT TECHNICAL SUPPORT.
NO FUNCTION OPERATES ON THE CRANE.	TRANSMITTER TURNED OFF	THE STATUS LIGHT ON THE TRANSMITTER SHOULD BE FLASHING GREEN WHEN NO BUTTON IS DEPRESSED	TURN ON TRANSMITTER. FOLLOW DE-ACTIVATING E-STOP PROCEDURES ON PAGE 3-3.0
	E-STOP ACTIVE	CHECK LCD SCREEN. YOU WOULD HAVE AN ERROR STATING E-STOP IS ACTIVE	TURN ON TRANSMITTER. FOLLOW DE-ACTIVATING E-STOP PROCEDURES ON PAGE 3-3.0
	RECEIVER TURNED OFF	CHECK THE LCD SCREEN. IF IT IS BLANK, THE RECEIVER IS TURNED OFF	MOST CRANES HAVE A TOGGLE SWITCH TO TURN ON CRANE. THIS IS USUALLY LOCATED IN THE CAB OR THE CRANE BOX.
	LOW BATTERY	WHILE THE TRANSMITTER IS TURNED ON, CHECK THE LCD SCREEN ON RECEIVER. BATTERY INDICATOR SHOULD BE AT LEAST 10%	REPLACE TRANSMITTER BATTERIES. IT REQUIRES (2) AA BATTERIES
	RECEIVER LOCKED UP	BOTTOM RIGHT CORNER IS A CIRCLE WITH AN ARROW. THIS SHOULD BE ROTATING AT ALL TIMES.	IF THE ARROW STOPS ROTATING, SHUT POWER OFF TO THE CRANE. LEAVE OFF 2 MINUTES AND TURN POWER BACK ON. IF THIS PROBLEM PERSISTS CONTACT TECHNICAL SUPPORT.
	TRUCK TILT ALARM ACTIVE	CHECK SCREEN FOR ERROR CODE. IT WOULD READ TRK TILT ALARM	THIS ERROR OCCURS WHEN THE TRUCK ANGLE EXCEEDS A 15 % SLOPE (8.5 DEGREES). RELOCATE THE TRUCK TO A FLATTER SURFACE.
THE FOLLOWING FUNCTIONS ARE INOPERABLE BOOM DOWN, EXTEND, HOIST UP	ANTI-2 BLOCK	CHECK SCREEN FOR ERROR CODE. IT WOULD READ ANTI-2 BLOCK ERROR.	VERIFY THAT THE TRAVELING BLOCK IS NOT IN CONTACT WITH BAIL. IF SO, HOIST DN AND CHECK FUNCTIONS AGAIN. INSPECT END OF BOOM TO VERIFY BAIL IS IN CONTACT WITH ANTI-2 BLOCK SWITCH. CHECK BAIL SPRING. CHECK CORD REEL & WIRE ON SIDE OF CRANE FOR DAMAGE.
	CRANE OVERLOAD	CHECK SCREEN FOR ERROR CODE. IT WOULD READ 100% OVERLOAD.	VERIFY LOAD ON CRANE DOES NOT EXCEED MOMENT RATING. REFERENCE LOAD CHART. TAP HOIST DOWN OR RETRACT FUNCTION TO RESET OVERLOAD. CHECK OPERATION AGAIN.
THE FOLLOWING FUNCTIONS ARE INOPERABLE EXTEND, RETRACT, HOIST UP, BOOM UP, ROTATE CW, & ROTATE CCW	LOW BOOM PRESSURE	CHECK SCREEN FOR ERROR CODE, IT WOULD READ BOOM PSI LOW	VERIFY BOOM IS NOT SUPPORTED BY ANYTHING EXCEPT THE LIFT CYLINDER. THIS WOULD INCLUDE THE BOOM SUPPORT ON THE VEHICLE.
ROTATE CW IS INOPERABLE	REACHED LIMIT FOR CLOCKWISE ROTATION	CHECK SCREEN FOR ERROR CODE, IT WOULD READ CW LIMIT	VERIFY THAT THE CW LIMIT SWITCH IS NOT ACTIVATED. THIS SHOULD BE NORMALLY CLOSED
	BAD COIL, OR DAMAGED WIRE	SCREEN WILL SHOW 0% NEXT TO SP BUT THE ROTATE CW FUNCTION WILL BE SHOWN	SWITCH COIL WITH ANOTHER FUNCTION. REPLACE COIL IF BAD, CHECK WIRING FOR ANY DAMAGE
ROTATE CCW IS INOPERABLE	REACHED LIMIT FOR COUNTER CLOCKWISE ROTATION	CHECK SCREEN FOR ERROR CODE, IT WOULD READ CCW LIMIT	VERIFY THAT THE CCW LIMIT SWITCH IS NOT ACTIVATED. THIS SHOULD BE NORMALLY CLOSED
	BAD COIL, OR DAMAGED WIRE	SCREEN WILL SHOW 0% NEXT TO SP BUT THE ROTATE CCW FUNCTION WILL BE SHOWN	SWITCH COIL WITH ANOTHER FUNCTION. REPLACE COIL IF BAD, CHECK WIRING FOR ANY DAMAGE

10006H

ELECTRICAL TROUBLESHOOTING CHART

PROBLEM	POSSIBLE CAUSE	DIAGNOSIS	SOLUTION
ALL FUNCTIONS ARE INOPERABLE EXCEPT BOOM DOWN AND HOIST DOWN	PESSURE TRANSDUCER IS UNPLUGGED	CHECK LCD SCREEN. IT WOULD READ "BOOM PT ERROR"	VERIFY THAT PRESSURE TRANSDUCER LOCATED ON THE LIFT CYLINDER VALVE BLOCK IS PLUGGED INTO THE HARNESS
ANY ONE FUNCTION IS NOT OPERABLE	CUT IN WIRE OR BAD COIL	CHECK THE SCREEN WHEN THE FUNCTION IS SELECTED, IT SHOULD SHOW THE FUNCTION OPERATING BUT 0% OF FUNCTION	SWITCH COIL WITH ANOTHER FUNCTION. REPLACE COIL IF BAD, CHECK WIRING FOR ANY DAMAGE
CRANE ROTATES SLOWLY	SLOW ROTATE ACTIVATED	CHECK LCD SCREEN. IT WOULD READ "SLOW ROTATE ACT"	THIS IS A SAFETY FEATURE TO PREVENT GETTING THE LOAD INTO AN UNSAFE CONDITION (EXCESSIVE SWINGING). SLOW ROTATE WILL REMAIN ACTIVE UNTIL THE LOAD IS REMOVED AND THE ROTATION FUNCTION IS DESELECTED.
	CLOSE TO MAX CRANE LOAD	WHEN THE TRUCK IS TILTED AND UNDER HIGH LOAD A DECREASE IN SPEED IS POSSIBLE	BRING LOAD IN CLOSER TO DECREASE THE LOAD
ALL FUNCTIONS OPERATE SLOWLY	WRONG SPEED FUNCTION IS SELECTED	CHECK THE TRANSMITTER. THERE SHOULD BE A GREEN LED DIRECTLY BELOW THE CURRENT SPEED SELECTED.	ADJUST THE SPEED TO THE PREFERRED SPEED SETTING. REFERENCE SPEED CONTROL SECTION ON PAGE 3-3.0
	BOOM ANGLE SENSOR ERROR	CHECK SCREEN FOR ERROR CODE. IT WOULD READ "BOOM SENSOR ERR"	VERIFY THAT THE BOOM SENSOR IS PLUGGED INTO THE HARNESS. CHECK CONNECTION BETWEEN HARNESS AND SENSOR. REMOVE ANY DEBRIS OR WATER FROM CONNECTOR AND RECONNECT
	90% LOAD ACTIVATED	CRANE IS AT OR OVER 90% OF IT'S RATED CAPACITY	THIS IS A SAFETY FEATURE TO PREVENT GETTING INTO AN UNSAFE CONDITION (SUDDEN MOVEMENT OF HEAVY LOAD). 90% LOAD WILL REMAIN ACTIVATED UNTIL LOAD IS DECREASED.
	TRUCK TILT WARNING	CRANE IS BETWEEN A 10% AND 15% SLOPE. CHECK LCD SCREEN FOR ERROR CODE, IT WOULD READ "TRK TILT WARN"	MOVE VEHICLE OR RAISE OUTRIGGER TO A MORE STABLE, LEVEL POSITION.

10006H

HYDRAULIC TROUBLESHOOTING CHART

PROBLEM	POSSIBLE CAUSE	DIAGNOSIS	SOLUTION
CRANE MOVES UNEXPECTEDLY	JAMMED CARTRIDGE	TRY TO MANUALLY OVERRIDE VALVE. IF UNABLE TO MOVE STEM, CARTRIDGE IS JAMMED	REPLACE CARTRIDGE.
	COUNTER-BALANCE SET TOO LOW (BOOM-UP & BOOM-DN)	ADJUST THE COUNTER-BALANCE OUT TO SEE IF MOVEMENT STOPS. REFERENCE PAGE 9.1 FOR PROCESS.	CONTACT AUTOCRANE FOR PROPER SETTING OF COUNTER-BALANCE. YOU MAY NEED TO REPLACE COUNTER-BALANCE.
NO FUNCTION OPERATES ON CRANE	PTO NOT ENGAGED	CHECK PTO ACTIVATION LIGHT USUALLY LOCATED IN CAB	ENGAGE PTO
	CRANE DIVERter VALVE NOT ENGAGED	IF USING AUTOCRANE OUTRIGGERS, CHECK CRANE DIVERter VALVE LOCATED AT THE OUTRIGGER VALVE.	ENGAGE CRANE DIVERter VALVE
	HYDRAULIC TANK IS LOW OR EMPTY	VISUALLY INSPECT THE HYDRAULIC OIL LEVEL IN THE TANK.	FILL TANK TO PROPER LEVEL.
	VEHICLE IS NOT RUNNING	VERIFY ENGINE IS RUNNING	START VEHICLE
ALL FUNCTIONS OPERATE SLOWLY	FAST IDLE NOT ACTIVATED	IF VEHICLE IS MANUAL TRANSMISSION, VERIFY FAST IDLE IS SHOWN ON THE LCD SCREEN	ACTIVATE FAST IDLE
	FILTER CLOGGED	IF NEXSTAR II, CHECK LCD SCREEN. IF NEXSTAR I, CHECK FILTER	REPLACE FILTER
EXCESSIVE HEAT DURING OPERATION	OPERATION TIME	CRANE OPERATION IS GENERALLY DESIGNED FOR INTERMITTENT DUTY (2 HOURS BEFORE OIL GETS HOT)	REDUCE USE OF CRANE, INCREASE HYDRAULIC TANK SIZE, OR ADD OIL COOLER
	UNLOADER VALVE OVERRIDDEN	CHECK UNLOADER VALVE AND VERIFY THE MANUAL OVERRIDE IS NOT ACTIVATED REF. PAGE 9-2.0	DEACTIVATE UNLOADER VALVE
	UNDERSIZED HYDRAULIC TANK	HYDRAULIC TANK SHOULD BE AT LEAST 2XGPM=GALLONS. THIS INCLUDES ANY OTHER ACCESSORIES THAT OPERATE FROM THE SAME TANK.	THIS IS A GENERAL RULE. MANY FACTORS THAT ALSO AFFECT HEAT IS AMBIENT TEMPERATURE, PRESSURE LOSSES, AND OPERATION TIME. FOR EXAMPLE, YOU CAN USE A SMALLER TANK IF MORE INTERMITTENT USE OR COLD ENVIROMENTS. YOU CAN INCREASE TANK SIZE, REDUCE PRESSURE LOSSES OR ADD OIL COOLER.

10006H LOAD CHART

P/N 460178026

10006H

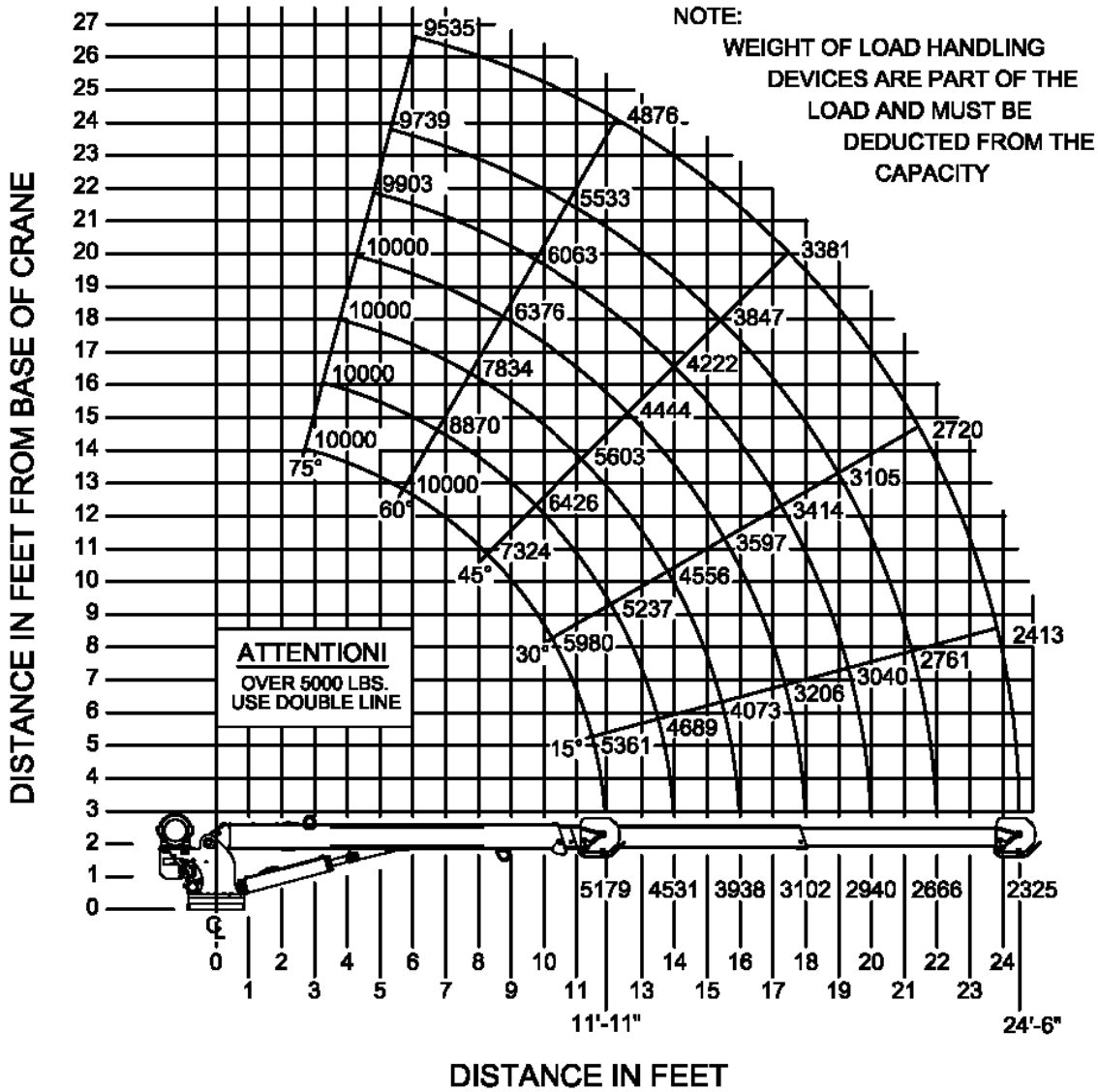

P/N 460178026 A

NOTES

CRANE PREVENTATIVE MAINTENANCE

PAINT FINISH PREVENTIVE MAINTENANCE INSTRUCTIONS

The paint finish on Auto Crane products can become damaged during normal use when chipped, scratched, exposed to harsh chemicals, cleaned with high pressure washers, etc. During periods when the truck is exposed to salt or other corrosive chemicals, Auto Crane products should be washed weekly. The paint finish should be inspected when washed or at least monthly. Any exposed bare metal or visible rust should be repaired immediately. Damaged paint on cranes should be repaired by:

1. Sanding the damaged areas to bare metal.
2. Solvent cleaning the sanded areas to remove sanding residue. Wipe dry with a clean cloth to remove any remaining residue.
3. Priming the sanded areas to a minimum of a 2 mil dry film thickness per the primer manufacturer's instructions. The primer must be compatible with Sherwin Williams' E2W932 epoxy primer.
4. Applying a 2 mil dry film thickness top coat paint per the manufacturer's instructions within 24 hours of applying the primer. The top coat paint must be compatible with Sherwin Williams' E2W932 epoxy primer and Sherwin Williams' Genesis polyurethane top coat paint. The final primer and top coat should have approximately a 4 mil dry film thickness.



P.O. Box 580697 * Tulsa, OK 74158-0697
4707 N. Mingo Rd. * Phone (918) 438-2760

LIMITED WARRANTY 1 YEAR PURCHASED REPLACEMENT PARTS

Auto Crane will warranty to the consumer for a period of (1) year from the date that a new Auto Crane replacement part was purchased from an authorized Auto Crane distributor. Each new Auto Crane part they sell will be free under normal use and service from defects in material and workmanship. Date of purchase will be honored as the date indicated on the Bill of Sale to the consumer.

The obligation of Auto Crane under this warranty does not apply to parts replaced under the limited warranty for a new Auto Crane product. The warranty for parts replaced under the limited warranty of a new Auto Crane product expires when the warranty for that product expires.

The obligation of Auto Crane under this warranty is limited to the replacement or repair of purchased replacement parts that appear to the manufacturer to be defective after review of documentation (Auto Crane Warranty Claim Form, photos, data, etc.) provided by the Auto Crane distributor and/or inspection of parts returned to Auto Crane. This warranty does not obligate Auto Crane to bear labor costs to replace the defective parts or travel time charges in connection with the replacement or repair of defective parts. Responsibility for customer's claims arising from misapplication, abuse, misuse or alteration of equipment or parts lies with the distributor or user and no warranty obligation is assumed in these circumstances by Auto Crane.

Auto Crane will in no event be liable for any consequential damages or contingent liabilities arising out of the failure of any Auto Crane product or parts to operate properly.

Auto Crane makes no warranty in respect to parts for component accessories, it being subject to the warranties of their respective manufacturers.

If field service, at the request of the distributor, is rendered and fault is found not to be with Auto Crane's product, the distributor shall pay the time and expense of the field representative.

Claims for service labor or other expenses that have incurred by the buyer without approval or authorization or Auto Crane will not be accepted.

When applying for warranty, claims may be handled by contacting your nearest authorized Auto Crane **Distributor**. **All claims are to be filed in writing on an Auto Crane Warranty Claim Form.**



P.O. Box 580697 * Tulsa, OK 74158-0697
4707 N. Mingo Rd. * Phone (918) 836-0463

LIMITED WARRANTY 2 YEAR PARTS AND LABOR

Auto Crane will warranty to the consumer for a period of (2) years parts and labor from the date of purchase. Each new Auto Crane unit they sell will be free under normal use and service from defects in material and workmanship. Date of purchase will be honored as the date indicated on the Bill of Sale, which must accompany the Warranty Registration and be on file with Auto Crane. Absent a valid Warranty Registration and appropriate documentation, the original date of manufacture, as indicated by the serial number on the product, will be used to determine the effective date of the 2 year warranty.

The obligation of Auto Crane under this warranty is limited to the replacement or repair of parts that appear to the manufacturer after review and/or inspection to be defective and paid flat rate labor for replacing defective parts. This warranty does not obligate Auto Crane to bear the travel time charges in connection with the replacement or repair of defective parts. Responsibility for customer's claims arising from misapplication, abuse, misuse or alteration of equipment or parts lies with the distributor or user and no warranty obligation is assumed in these circumstances by Auto Crane.

Auto Crane will in no event be liable for any consequential damages or contingent liabilities arising out of the failure of any Auto Crane Product or parts to operate properly.

Auto Crane makes no warranty in respect to component accessories, it being subject to the warranties of their respective manufacturers.

If field service, at the request of the distributor, is rendered and fault is found not to be with Auto Crane's product, the distributor shall pay the time and expense of the field representative.

Claims for service labor or other expenses that have incurred by the buyer without approval or authorization or Auto Crane will not be accepted.

When applying for warranty, claims may be handled by contacting your nearest authorized Auto Crane **Distributor**. **All claims are to be filed in writing on an Auto Crane Warranty Claim Form.**

AUTO CRANE COMPANY IS UNDER NO OBLIGATION TO EXTEND THIS WARRANTY TO ANY CUSTOMER FOR WHICH AN AUTO CRANE DELIVERY REPORT FORM HAS NOT BEEN COMPLETED AND ON FILE WITH AUTO CRANE COMPANY